



FCC TEST REPORT

REPORT NO.: RF111021C17

MODEL NO.: CA10002

FCC ID: NKR-VWL10

RECEIVED: Oct. 21, 2011

TESTED: Nov. 01 ~ Nov. 03, 2011

ISSUED: Nov. 08, 2011

APPLICANT: Wistron NeWeb Corp.

ADDRESS: 20 Park Avenue II, Hsinchu Science Park, Hsinchu
308, Taiwan, R.O.C.

ISSUED BY: Bureau Veritas Consumer Products Services
(H.K.) Ltd., Taoyuan Branch

LAB ADDRESS: No. 47, 14th Ling, Chia Pau Vil., Lin Kou Dist.,
New Taipei City, Taiwan (R.O.C)

TEST LOCATION: No. 19, Hwa Ya 2nd Rd, Wen Hwa Tsuen, Kwei
Shan Hsiang, Taoyuan Hsien 333, Taiwan, R.O.C.

This test report consists of 43 pages in total. It may be duplicated completely for legal use with the approval of the applicant. It should not be reproduced except in full, without the written approval of our laboratory. The client should not use it to claim product, certification, approval or endorsement by TAF or any government agency. The test results in the report only apply to the tested sample.





TABLE OF CONTENTS

RELEASE CONTROL RECORD	4
1 CERTIFICATION	5
2 SUMMARY OF TEST RESULTS	6
2.1 MEASUREMENT UNCERTAINTY	6
3 GENERAL INFORMATION.....	7
3.1 GENERAL DESCRIPTION OF EUT	7
3.2 DESCRIPTION OF TEST MODES.....	8
3.2.1 CONFIGURATION OF SYSTEM UNDER TEST	8
3.2.2 TEST MODE APPLICABILITY AND TESTED CHANNEL DETAIL	9
3.3 GENERAL DESCRIPTION OF APPLIED STANDARDS	12
3.4 DESCRIPTION OF SUPPORT UNITS	12
4 TEST TYPES AND RESULTS	13
4.1 OUTPUT POWER MEASUREMENT	13
4.1.1 LIMITS OF OUTPUT POWER MEASUREMENT	13
4.1.2 TEST INSTRUMENTS	14
4.1.3 TEST PROCEDURES	15
4.1.4 TEST SETUP	16
4.1.5 EUT OPERATING CONDITIONS	16
4.1.6 TEST RESULTS	17
4.2 FREQUENCY STABILITY MEASUREMENT	20
4.2.1 LIMITS OF FREQUENCY STABILITY MEASUREMENT	20
4.2.2 TEST INSTRUMENTS	20
4.2.3 TEST PROCEDURE	21
4.2.4 TEST SETUP	21
4.2.5 EUT OPERATING CONDITIONS	21
4.2.6 TEST RESULTS	22
4.3 OCCUPIED BANDWIDTH MEASUREMENT	23
4.3.1 LIMITS OF OCCUPIED BANDWIDTH MEASUREMENT	23
4.3.2 TEST INSTRUMENTS	23
4.3.3 TEST PROCEDURES	23
4.3.4 TEST SETUP	24
4.3.5 EUT OPERATING CONDITIONS	24
4.3.6 TEST RESULTS	25
4.4 PEAK TO AVERAGE RATIO	27
4.4.1 LIMITS OF PEAK TO AVERAGE RATIO MEASUREMENT	27
4.4.2 TEST INSTRUMENTS	27
4.4.3 TEST PROCEDURES	27
4.4.4 TEST SETUP	27
4.4.5 EUT OPERATING CONDITION	27
4.4.6 TEST RESULTS	28
4.5 BAND EDGE MEASUREMENT	30
4.5.1 LIMITS OF BAND EDGE MEASUREMENT	30
4.5.2 TEST INSTRUMENTS	30



4.5.3	TEST PROCEDURES	31
4.5.4	TEST SETUP	31
4.5.5	EUT OPERATING CONDITIONS	31
4.5.6	TEST RESULTS	32
4.6	CONDUCTED SPURIOUS EMISSIONS	33
4.6.1	LIMITS OF CONDUCTED SPURIOUS EMISSIONS MEASUREMENT	33
4.6.2	TEST INSTRUMENTS	33
4.6.3	TEST PROCEDURE	34
4.6.4	TEST SETUP	34
4.6.5	EUT OPERATING CONDITIONS	34
4.6.6	TEST RESULTS	35
4.7	RADIATED EMISSION MEASUREMENT	38
4.7.1	LIMITS OF RADIATED EMISSION MEASUREMENT	38
4.7.2	TEST INSTRUMENTS	38
4.7.3	TEST PROCEDURES	38
4.7.4	TEST SETUP	39
4.7.5	DEVIATION FROM TEST STANDARD	39
4.7.6	EUT OPERATING CONDITIONS	39
4.7.7	TEST RESULTS	40
5	INFORMATION ON THE TESTING LABORATORIES	42
6	APPENDIX A – MODIFICATIONS RECORDERS FOR ENGINEERING CHANGES TO THE EUT BY THE LAB.....	43



RELEASE CONTROL RECORD

ISSUE NO.	REASON FOR CHANGE	DATE ISSUED
Original release	N/A	Nov. 08, 2011



1 CERTIFICATION

PRODUCT: Cantenna

Model No.: CA10002

BRAND: WNC

APPLICANT: Wistron NeWeb Corp.

TEST SAMPLE: ENGINEERING SAMPLE

TESTED: Nov. 01 ~ Nov. 03, 2011

TEST STANDARDS : FCC Part 27

FCC Part 2

ANSI C63.4-2003

The above equipment (model: CA10002) has been tested by **Bureau Veritas Consumer Products Services (H.K.) Ltd., Taoyuan Branch**, and found compliance with the requirement of the above standards. The test record, data evaluation & Equipment Under Test (EUT) configurations represented herein are true and accurate accounts of the measurements of the sample's EMC characteristics under the conditions specified in this report.

PREPARED BY : Andrea Hsia , DATE : Nov. 08, 2011
Andrea Hsia / Specialist

APPROVED BY : Gary Chang , DATE : Nov. 08, 2011
Gary Chang / Technical Manager



A D T

2 SUMMARY OF TEST RESULTS

The EUT has been tested according to the following specifications:

OPERATING BAND			
STANDARD SECTION	TEST TYPE AND LIMIT	RESULT	REMARK
2.1046 27.50(b)(10)	Effective radiated power	PASS	Meet the requirement of limit. Max. e.r.p is 24.1dBm
2.1055 27.54	Frequency Stability	PASS	Meet the requirement of limit.
2.1049	Occupied Bandwidth	PASS	Meet the requirement of limit.
27.50(d)(5)	Peak to average ratio	PASS	Meet the requirement of limit.
27.53(c)(2)	Band Edge Measurements	PASS	Meet the requirement of limit.
2.1051 27.53(c)(2)	Conducted Spurious Emissions	PASS	Meet the requirement of limit.
2.1051 27.53(c)(4)	Emission in the 736–775 MHz and 793–805 MHz band	PASS	Meet the requirement of limit.
2.1053 27.53(c)(2)	Radiated Spurious Emissions	PASS	Meet the requirement of limit. Minimum passing margin is -28.0dB at 589.84MHz.
2.1053 27.53(f)	Emissions in the band 1559–1610 MHz	PASS	Meet the requirement of limit. Minimum passing margin is -2.7dB at 1572.8MHz.

2.1 MEASUREMENT UNCERTAINTY

Where relevant, the following measurement uncertainty levels have been estimated for tests performed on the EUT as specified in CISPR 16-4-2:

MEASUREMENT	FREQUENCY	UNCERTAINTY
Radiated emissions	30MHz ~ 200MHz	3.34 dB
	200MHz ~1000MHz	3.35 dB
	1GHz ~ 18GHz	2.26 dB
	18GHz ~ 40GHz	1.94 dB

This uncertainty represents an expanded uncertainty expressed at approximately the 95% confidence level using a coverage factor of k=2.



A D T

3 GENERAL INFORMATION

3.1 GENERAL DESCRIPTION OF EUT

PRODUCT	Cantenna
MODEL NO.	CA10002
FCC ID	NKR-VWL10
NOMINAL VOLTAGE	15~30Vdc
MODULATION TECHNOLOGY	QPSK, 16QAM
MODULATION TYPE	Downlink: OFDMA Uplink: SC-FDMA
FREQUENCY RANGE	Downlink: 746~756MHz Uplink: 777-787MHz
CHANNEL BANDWIDTH	10MHz
MAX. ERP POWER	24.1dBm (257.0mW)
ANTENNA TYPE	Dual polarization patch antenna with 5.4dBi gain
OPERATION TEMPERATURE RANGE	-40°C ~ 60°C
I/O PORTS	Refer to user's manual
DATA CABLE	NA
ACCESSORY DEVICES	NA

NOTE:

1. After pretest of output power and spurious emission under below configurations, QPSK with 1RB at upper edge was found to be worst case and was selected for the final test.

MODULATION	RB SETTING
QPSK	1 RB allocated at the lower edge
QPSK	1 RB allocated at the upper edge
QPSK	50% RB allocation centered
QPSK	100% RB allocation
16QAM	1 RB allocated at the lower edge
16QAM	1 RB allocated at the upper edge
16QAM	50% RB allocation centered
16QAM	100% RB allocation

2. The above EUT information is declared by manufacturer and for more detailed feature description, please refer to the manufacturer's specifications or User's Manual.

3.2 DESCRIPTION OF TEST MODES

One channel had been tested.

CHANNEL BANDWIDTH	10MHz
CHANNEL	23230
FREQUENCY (MHz)	782.0

3.2.1 CONFIGURATION OF SYSTEM UNDER TEST

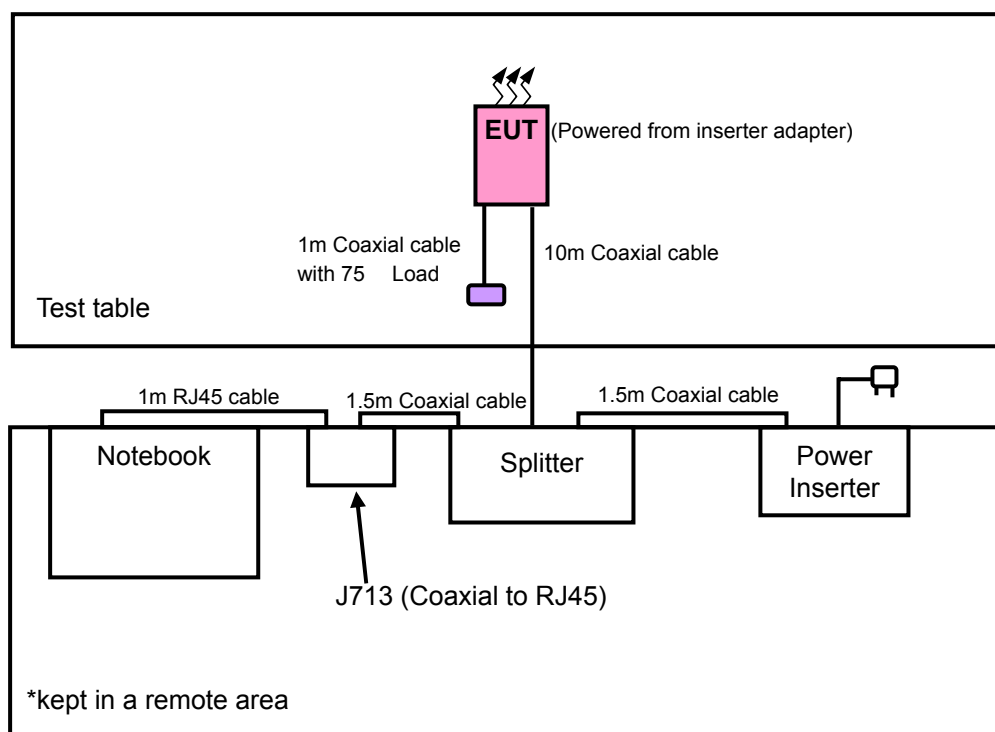

3.2.2 TEST MODE APPLICABILITY AND TESTED CHANNEL DETAIL

EUT CONFIGURE MODE	APPLICABLE TO								DESCRIPTION
	OP	FS	OB	PA	BE	CE	RE<1G	RE≥1G	
-	V	V	V	V	V	V	V	V	-

Where **OP**: Output power **FS**: Frequency stability
OB: Occupied bandwidth **PA**: Peak to Average Ratio
BE: Band edge **CE**: Conducted spurious emissions
RE<1G: Radiated emission below 1GHz **RE≥1G**: Radiated emission above 1GHz

OUTPUT POWER MEASUREMENT:

- Pre-Scan has been conducted to determine the worst-case mode from all possible combinations between available modulations, XYZ axis and antenna ports (if EUT with antenna diversity architecture).
- Following channel(s) was (were) selected for the final test as listed below.

EUT CONFIGURE MODE	OPERATING BAND	FREQUENCY BAND (MHz)	TESTED FREQUENCY (MHz)	MODULATION TECHNOLOGY
-	LTE	777-787	782.0	QPSK, 16QAM

FREQUENCY STABILITY MEASUREMENT:

- Pre-Scan has been conducted to determine the worst-case mode from all possible combinations between available modulations and antenna ports (if EUT with antenna diversity architecture).
- Following channel(s) was (were) selected for the final test as listed below.

EUT CONFIGURE MODE	OPERATING BAND	FREQUENCY BAND (MHz)	TESTED FREQUENCY (MHz)	MODULATION TECHNOLOGY
-	LTE	777-787	782.0	QPSK

OCCUPIED BANDWIDTH MEASUREMENT:

- This item includes all test value of each mode, but only includes spectrum plot of worst value of each mode.
- Following channel(s) was (were) selected for the final test as listed below.

EUT CONFIGURE MODE	OPERATING BAND	FREQUENCY BAND (MHz)	TESTED FREQUENCY (MHz)	MODULATION TECHNOLOGY
-	LTE	777-787	782.0	QPSK, 16QAM

PEAK TO AVERAGE RATIO:

- This item includes all test value of each mode, but only includes spectrum plot of worst value of each mode.
- Pre-Scan has been conducted to determine the worst-case mode from all possible combinations between available modulations, XYZ axis and antenna ports (if EUT with antenna diversity architecture).
- Following channel(s) was (were) selected for the final test as listed below.

EUT CONFIGURE MODE	OPERATING BAND	FREQUENCY BAND (MHz)	TESTED FREQUENCY (MHz)	MODULATION TECHNOLOGY
-	LTE	777-787	782.0	QPSK, 16QAM

BAND EDGE MEASUREMENT:

- Pre-Scan has been conducted to determine the worst-case mode from all possible combinations between available modulations, XYZ axis and antenna ports (if EUT with antenna diversity architecture).
- Following channel(s) was (were) selected for the final test as listed below.

EUT CONFIGURE MODE	OPERATING BAND	FREQUENCY BAND (MHz)	TESTED FREQUENCY (MHz)	MODULATION TECHNOLOGY
-	LTE	777-787	782.0	QPSK

CONDUCTED SPURIOUS EMISSIONS MEASUREMENT:

- Pre-Scan has been conducted to determine the worst-case mode from all possible combinations between available modulations and antenna ports (if EUT with antenna diversity architecture).
- Following channel(s) was (were) selected for the final test as listed below.

EUT CONFIGURE MODE	OPERATING BAND	FREQUENCY BAND (MHz)	TESTED FREQUENCY (MHz)	MODULATION TECHNOLOGY
-	LTE	777-787	782.0	QPSK

RADIATED EMISSION MEASUREMENT (BELOW 1 GHz):

- Pre-Scan has been conducted to determine the worst-case mode from all possible combinations between available modulations, XYZ axis and antenna ports (if EUT with antenna diversity architecture).
- Following channel(s) was (were) selected for the final test as listed below.

EUT CONFIGURE MODE	OPERATING BAND	FREQUENCY BAND (MHz)	TESTED FREQUENCY (MHz)	MODULATION TECHNOLOGY
-	LTE	777-787	782.0	QPSK

RADIATED EMISSION MEASUREMENT (ABOVE 1 GHz):

- Pre-Scan has been conducted to determine the worst-case mode from all possible combinations between available modulations, XYZ axis and antenna ports (if EUT with antenna diversity architecture).
- Following channel(s) was (were) selected for the final test as listed below.

EUT CONFIGURE MODE	OPERATING BAND	FREQUENCY BAND (MHz)	TESTED FREQUENCY (MHz)	MODULATION TECHNOLOGY
-	LTE	777-787	782.0	QPSK

TEST CONDITION:

APPLICABLE TO	ENVIRONMENTAL CONDITIONS	INPUT POWER (SYSTEM)	TESTED BY
OP	23deg. C, 63%RH	120Vac, 60Hz	Long Chen
FS	23deg. C, 63%RH	120Vac, 60Hz	Long Chen
OB	23deg. C, 63%RH	120Vac, 60Hz	Long Chen
PA	23deg. C, 63%RH	120Vac, 60Hz	Long Chen
BE	23deg. C, 63%RH	120Vac, 60Hz	Long Chen
CE	23deg. C, 63%RH	120Vac, 60Hz	Long Chen
RE < 1G	27deg. C, 65%RH	120Vac, 60Hz	Sun Lin
RE ≥ 1G	27deg. C, 65%RH	120Vac, 60Hz	Sun Lin

3.3 GENERAL DESCRIPTION OF APPLIED STANDARDS

The EUT is a LTE product. According to the specifications of the manufacturer, it must comply with the requirements of the following standards:

FCC 47 CFR Part 2

FCC 47 CFR Part 27

ANSI C63.4-2003

ANSI/TIA/EIA-603-C 2004

All test items have been performed and recorded as per the above standards.

NOTE: The EUT is also considered as a kind of computer peripheral, because the connection to computer is necessary for typical use. It has been verified to comply with the requirements of FCC Part 15, Subpart B, Class B (DoC). The test report has been issued separately.

3.4 DESCRIPTION OF SUPPORT UNITS

The EUT has been tested as an independent unit together with other necessary accessories or support units. The following support units or accessories were used to form a representative test configuration during the tests.

NO.	PRODUCT	BRAND	MODEL NO.	SERIAL NO.	FCC ID
1	POWER INSERTER	DIRECTV	PI29R1-03	NA	NA
2	SPLITTER	DIRECTV	MSPLIT4R1-01	NA	NA
3	ADAPTER	DIRECTV	ENCABB1MR0-01	NA	NA
4	NOTEBOOK	DELL	D531	CN-0XM006-486 43-81U-2973	QDS-BRCM1020

NO.	SIGNAL CABLE DESCRIPTION OF THE ABOVE SUPPORT UNITS
1	1.5m Coaxial cable
2	10m Coaxial cable
3	NA
4	1.5m Coaxial cable

NOTE:

1. All power cords of the above support units are non shielded (1.8m).
2. Item 1 ~ 4 acted as a communication partner to transfer data.
3. Item 1 ~ 3 & Coaxial cables were supplied from client.



4 TEST TYPES AND RESULTS

4.1 OUTPUT POWER MEASUREMENT

4.1.1 LIMITS OF OUTPUT POWER MEASUREMENT

Portable stations (hand-held devices) operating in the 776-793 MHz band are limited to 3 watts ERP



4.1.2 TEST INSTRUMENTS

DESCRIPTION & MANUFACTURER	MODEL NO.	SERIAL NO.	DATE OF CALIBRATION	DUE DATE OF CALIBRATION
Test Receiver ROHDE & SCHWARZ	ESIB7	100212	Aug. 02, 2011	Aug. 01, 2012
Spectrum Analyzer ROHDE & SCHWARZ	FSP 40	100041	Jul. 21, 2011	Jul. 20, 2012
BILOG Antenna SCHWARZBECK	VULB9168	9168-160	Apr. 13, 2011	Apr. 12, 2012
HORN Antenna SCHWARZBECK	9120D	209	Aug. 25, 2011	Aug. 24, 2012
HORN Antenna SCHWARZBECK	BBHA 9170	BBHA9170243	Dec. 27, 2010	Dec. 26, 2011
Preamplifier Agilent	8447D	2944A10633	Oct. 29, 2011	Oct. 28, 2012
Preamplifier Agilent	8449B	3008A01964	Oct. 29, 2011	Oct. 28, 2012
RF signal cable HUBER+SUHNNER	SUCOFLEX 104	295014/4	Aug. 19, 2011	Aug. 18, 2012
RF signal cable HUBER+SUHNNER	SUCOFLEX 104	12738/6	Aug. 19, 2011	Aug. 18, 2012
Software ADT.	ADT_Radiated_ V7.6.15.9.2	NA	NA	NA
Antenna Tower inn-co GmbH	MA 4000	013303	NA	NA
Antenna Tower Controller inn-co GmbH	CO2000	017303	NA	NA
Turn Table ADT.	TT100.	TT93021703	NA	NA
Turn Table Controller ADT.	SC100.	SC93021703	NA	NA

- NOTE:**
1. The calibration interval of the above test instruments is 12 months and the calibrations are traceable to NML/ROC and NIST/USA.
 2. The test was performed in HwaYa Chamber 3.
 3. The horn antenna and HP preamplifier (model: 8449B) are used only for the measurement of emission frequency above 1GHz if tested.
 4. The FCC Site Registration No. is 988962.
 5. The IC Site Registration No. is IC 7450F-3.

4.1.3 TEST PROCEDURES

ERP MEASUREMENT:

- a. The EUT was set up for the maximum power with LTE link data modulation. The power was measured with Angilent Spectrum Analyzer. All measurements were done at specific channel. RWB and VBW is 10MHz for LTE.
- b. E.I.R.P power measurement. In the semi-anechoic chamber, EUT placed on the 0.8m height of Turn Table, rotated the table around 360 degrees to search the maximum radiation power and receiver antenna shall be rotated vertical and horizontal polarization and moved height from 1m to 4m to find the maximum polar radiated power. The “Read Value” is the spectrum reading the maximum power value.
- c. The substitution horn antenna is substituted for EUT at the same position and signals generator export the CW signal to the substitution antenna via a TX cable. Rotated the Turn Table and moved receiving antenna to find the maximum radiation power. Adjust output power level of S.G to get a Value of spectrum reading equal to “Read Value” of step a. Record the power level of S.G
- d. $EIRP = \text{Output power level of S.G} - \text{TX cable loss} + \text{Antenna gain of substitution horn}$
- e. $E.R.P = E.I.R.P - 2.15 \text{ dB}$

CONDUCTED POWER MEASUREMENT:

- a. The EUT was set up for the maximum power with LTE link data modulation and link up with simulator.
- b. Set the EUT to transmit under specific channel and record the power level shown on simulator.

4.1.4 TEST SETUP

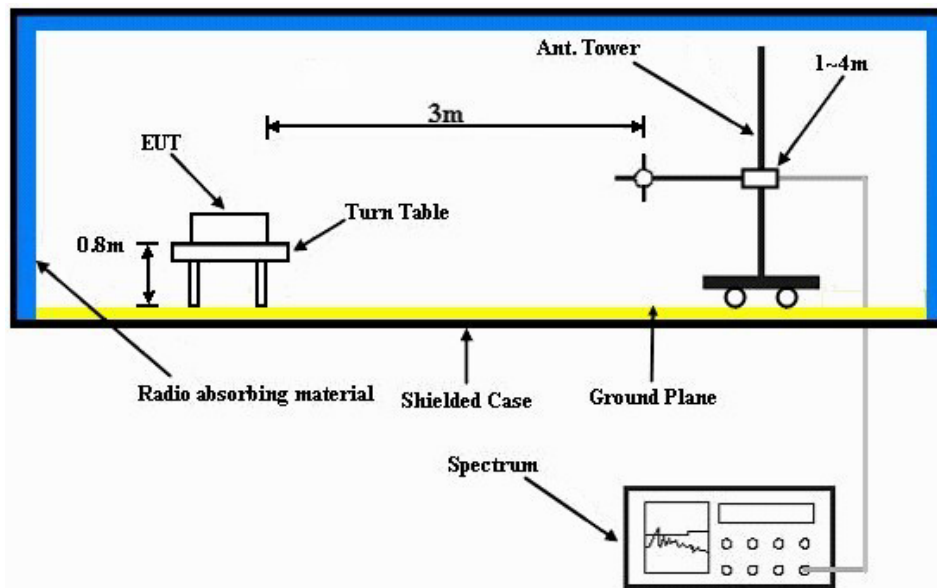

For the actual test configuration, please refer to the attached file (Test Setup Photo).

CONDUCTED POWER MEASUREMENT:

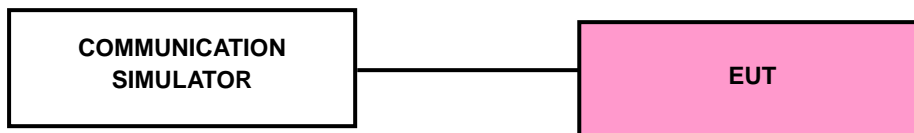

For the actual test configuration, please refer to the related item – Photographs of the Test Configuration.

4.1.5 EUT OPERATING CONDITIONS

- a. The EUT makes a call to the communication simulator.
- b. The communication simulator station system controlled a EUT to export maximum output power under transmission mode and specific channel frequency.

4.1.6 TEST RESULTS

CONDUCTED AVERAGE POWER TABLE, QPSK

CONDUCTED OUTPUT POWER (QPSK 1 RB ALLOCATED AT THE LOWER EDGE)					
CHANNEL NO.	FREQUENCY (MHz)	RAW VALUE (dBm)	CORRECTION FACTOR (dB)	OUTPUT POWER	
				dBm	mW
23230	782.0	-2.07	24.30	22.23	167.1

CONDUCTED OUTPUT POWER (QPSK 1 RB ALLOCATED AT THE UPPER EDGE)					
CHANNEL NO.	FREQUENCY (MHz)	RAW VALUE (dBm)	CORRECTION FACTOR (dB)	OUTPUT POWER	
				dBm	mW
23230	782.0	-1.72	24.30	22.58	181.1

CONDUCTED OUTPUT POWER (QPSK 50% RB ALLOCATION CENTERED)					
CHANNEL NO.	FREQUENCY (MHz)	RAW VALUE (dBm)	CORRECTION FACTOR (dB)	OUTPUT POWER	
				dBm	mW
23230	782.0	-2.75	24.30	21.55	142.9

CONDUCTED OUTPUT POWER (QPSK 100% RB ALLOCATION)					
CHANNEL NO.	FREQUENCY (MHz)	RAW VALUE (dBm)	CORRECTION FACTOR (dB)	OUTPUT POWER	
				dBm	mW
23230	782.0	-2.83	24.30	21.47	140.3

CONDUCTED AVERAGE POWER TABLE, 16QAM

CONDUCTED OUTPUT POWER (16QAM 1 RB ALLOCATED AT THE LOWER EDGE)					
CHANNEL NO.	FREQUENCY (MHz)	RAW VALUE (dBm)	CORRECTION FACTOR (dB)	OUTPUT POWER	
				dBm	mW
23230	782.0	-2.47	24.30	21.83	152.4

CONDUCTED OUTPUT POWER (16QAM 1 RB ALLOCATED AT THE UPPER EDGE)					
CHANNEL NO.	FREQUENCY (MHz)	RAW VALUE (dBm)	CORRECTION FACTOR (dB)	OUTPUT POWER	
				dBm	mW
23230	782.0	-2.12	24.30	22.18	165.2

CONDUCTED OUTPUT POWER (16QAM 50% RB ALLOCATION CENTERED)					
CHANNEL NO.	FREQUENCY (MHz)	RAW VALUE (dBm)	CORRECTION FACTOR (dB)	OUTPUT POWER	
				dBm	mW
23230	782.0	-3.56	24.30	20.74	118.6

CONDUCTED OUTPUT POWER (16QAM 100% RB ALLOCATION)					
CHANNEL NO.	FREQUENCY (MHz)	RAW VALUE (dBm)	CORRECTION FACTOR (dB)	OUTPUT POWER	
				dBm	mW
23230	782.0	-3.95	24.30	20.35	108.4

REMARKS: 1. Output Power (dBm) = Raw Value (dBm) + Correction Factor (dB).
 2. Correction Factor (dB) = Power Splitter Loss (dB) + Cable Loss (dB).



A D T

ERP

ERP POWER (QPSK 1 RB ALLOCATED AT THE UPPER EDGE) HORIZONTAL							
NO.	FREQ. (MHz)	READING (dB-m)	S.G POWER VALUE (dBm)	CORRECTION FACTOR (dB)	ERP (dBm)	LIMIT (dBm)	MARGIN (dB)
1	782.0	-16.0	17.4	-0.9	14.3	34.8	-20.5
ERP POWER (QPSK 1 RB ALLOCATED AT THE UPPER EDGE) VERTICAL							
NO.	FREQ. (MHz)	READING (dBm)	S.G POWER VALUE (dBm)	CORRECTION FACTOR (dB)	ERP (dBm)	LIMIT (dBm)	MARGIN (dB)
1	782.0	-3.5	27.1	-0.9	24.1	34.8	-10.7

NOTE: ERP(dBm) = S.G Power Value (dBm) + Correction Factor (dB).
Correction Factor = gain of substitution antenna + cable loss



4.2 FREQUENCY STABILITY MEASUREMENT

4.2.1 LIMITS OF FREQUENCY STABILITY MEASUREMENT

According to the FCC part 27.54 shall be tested the frequency stability. The rule is defined that” The frequency stability shall be sufficient to ensure that the fundamental emissions stay within the authorized bands of operation. The test extreme voltage is according to the 2.1055(d)(1) Vary primary supply voltage from 85 to 115 percent of the nominal value for other than hand carried battery equipment and the extreme temperature rule is comply with the 2.1055(a)(1) –30 ~50 .

4.2.2 TEST INSTRUMENTS

DESCRIPTION & MANUFACTURER	MODEL NO.	SERIAL NO.	DATE OF CALIBRATION	DUE DATE OF CALIBRATION
Spectrum Analyzer Agilent	E4446A	MY44360124	Dec. 29, 2010	Dec. 28, 2011
Signal Generator Agilent	E4438C	MY47271120	Feb. 18, 2011	Feb. 18, 2012
Suhner RF cable	SUCOFLEX 104	257029	Jan. 07, 2011	Jan. 06, 2012
WIT Standard Temperature & Humidity Chamber	MHU-225AU	920842	Jun. 15, 2011	Jun. 14, 2012

NOTE: The calibration interval of the above test instruments is 12 months. And the calibrations are traceable to NML/ROC and NIST/USA.

4.2.3 TEST PROCEDURE

- a. The oven room could control the temperatures and humidity.
- b. Power must be removed when changing from one temperature to another or one voltage to another voltage. Power warm up is at least 15 min and power applied should perform before recording frequency error.
- c. Laptop pc is connected the external power supply to control the AC input power. The various Volts from the minimum 93.5Volts to126.5Volts. Each step shall be record the frequency error rate.
- d. The temperature range step is 10 degrees in this test items. All temperature levels shall be hold the ± 0.5 during the measurement testing.
- e. The each temperature step shall be at least 0.5 hours, consider the EUT could be test under the stability condition.

NOTE: The frequency error was recorded frequency error from the communication simulator.

4.2.4 TEST SETUP

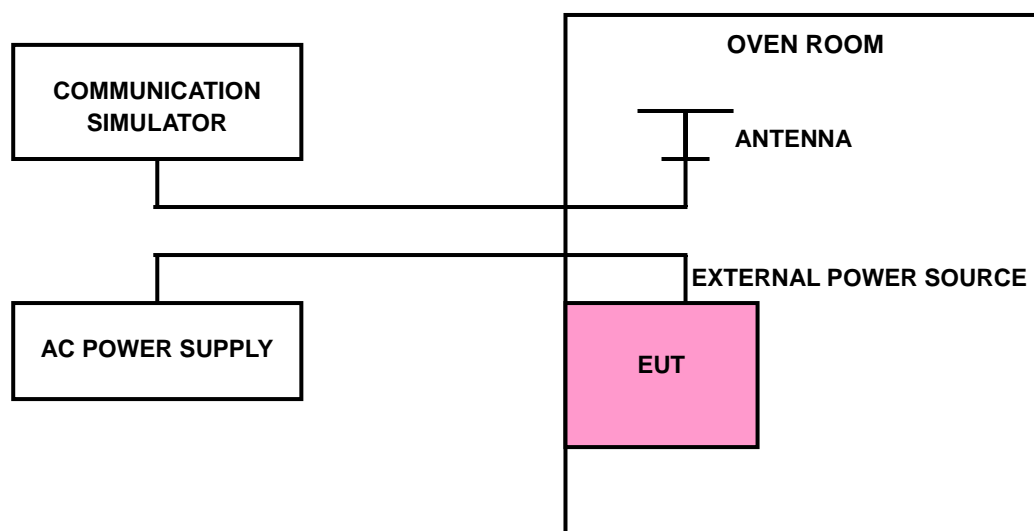

4.2.5 EUT OPERATING CONDITIONS

Same as 4.1.5.



4.2.6 TEST RESULTS

AFC FREQUENCY ERROR VS. VOLTAGE		
VOLTAGE (Volts)	MEASURED ERROR (ppm)	LIMIT (ppm)
126.5	0.070	2.5
93.5	0.068	

AFC FREQUENCY ERROR VS. TEMP.		
TEMP. (MEASURED ERROR (ppm)	LIMIT (ppm)
60	0.065	2.5
50	0.064	
40	0.066	
30	0.069	
20	0.068	
10	0.070	
0	0.073	
-10	0.070	
-20	0.073	
-30	0.072	
-40	0.074	



4.3 OCCUPIED BANDWIDTH MEASUREMENT

4.3.1 LIMITS OF OCCUPIED BANDWIDTH MEASUREMENT

The width of a frequency band such that, below the lower and above the upper frequency limits, the mean powers emitted are each equal to a specified percentage 0.5 % of the total mean power of a given emission.

4.3.2 TEST INSTRUMENTS

DESCRIPTION & MANUFACTURER	MODEL NO.	SERIAL NO.	DATE OF CALIBRATION	DUE DATE OF CALIBRATION
Mini-Circuits Power Splitter	ZAPD-4	NA	Mar. 24, 2011	Mar. 23, 2012
Hewlett Packard RF cable	8120-6192	01428251	NA	NA
JFW 20dB attenuation	50HF-020-SMA	NA	NA	NA
RF cable	SUCOFLEX 104	257029	Jan. 07, 2011	Jan. 06, 2012
Agilent Spectrum Analyzer	E4446A	MY44360128	Feb. 22, 2011	Feb. 21, 2012

NOTE: The calibration interval of the above test instruments is 12 months and the calibrations are traceable to NML/ROC and NIST/USA.

4.3.3 TEST PROCEDURES

- a. The conducted occupied bandwidth used the power splitter via EUT RF power connector between signal generator and spectrum analyzer.
- b. Use OBW measurement function of Spectrum analyzer to measure 99 % occupied bandwidth.

4.3.4 TEST SETUP

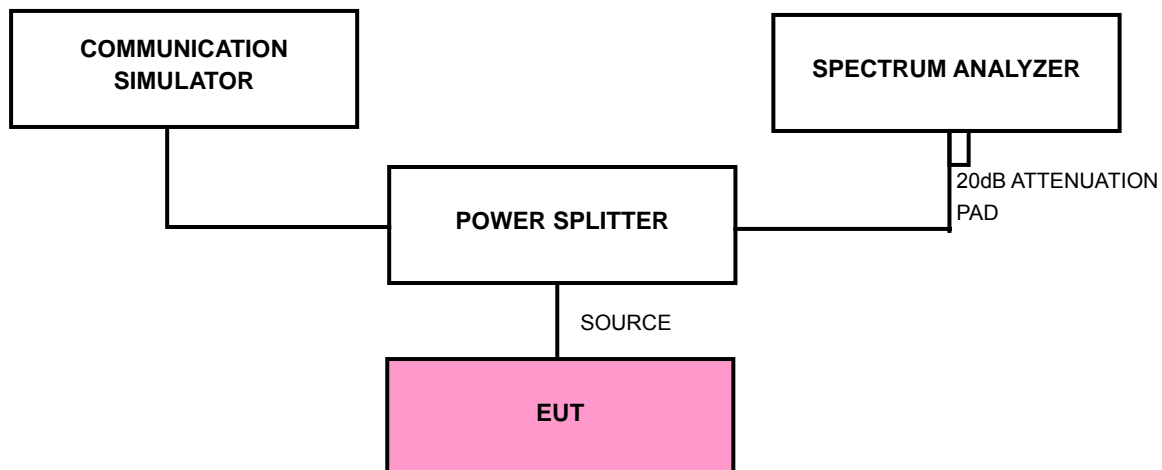

4.3.5 EUT OPERATING CONDITIONS

Same as 4.1.5.

4.3.6 TEST RESULTS

QPSK

FREQUENCY (MHz)	99% OCCUPIED BANDWIDTH (MHz)
782.0	8.9781

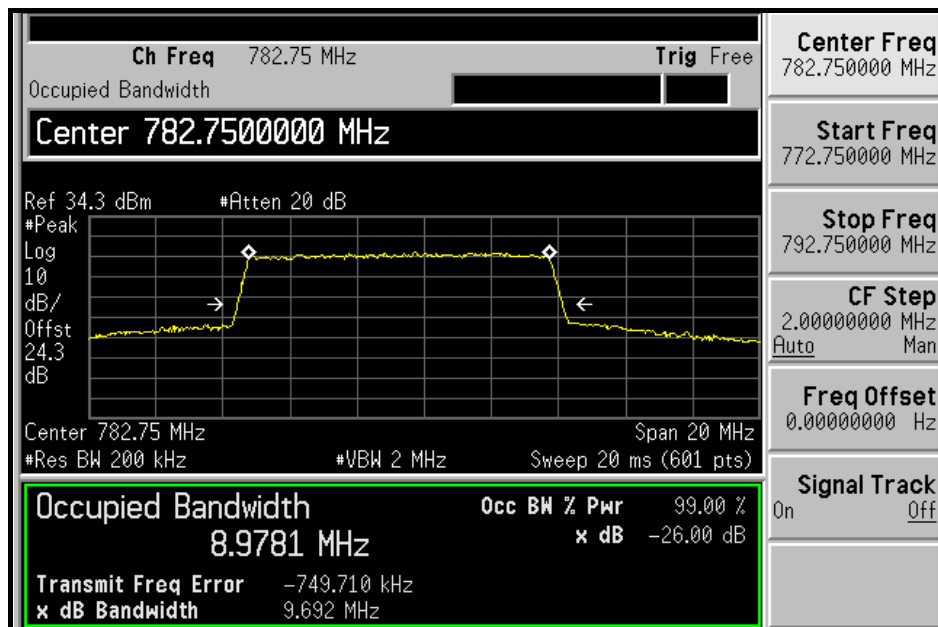

16QAM

FREQUENCY (MHz)	99% OCCUPIED BANDWIDTH (MHz)
782.0	8.9474

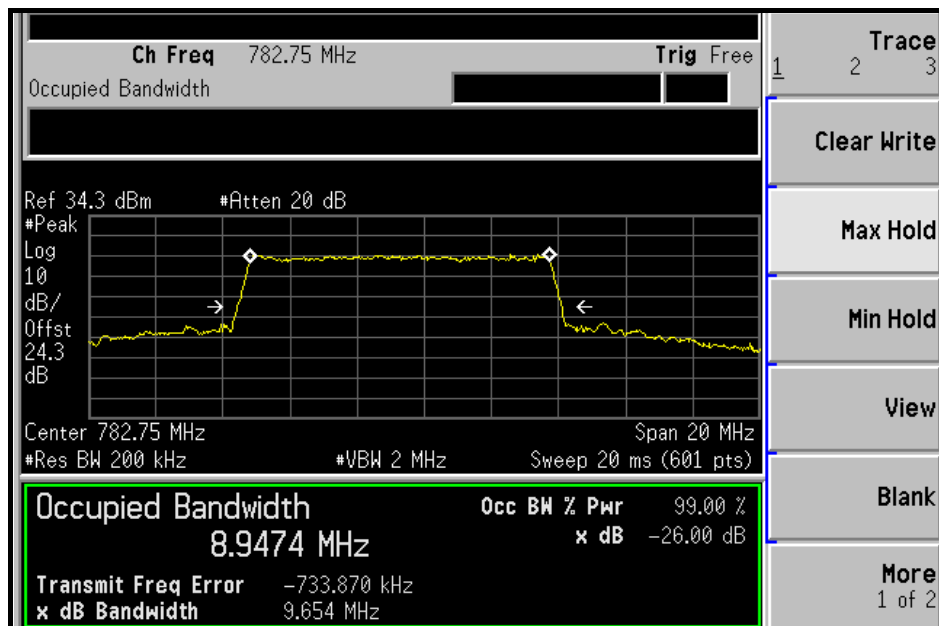



4.4 PEAK TO AVERAGE RATIO

4.4.1 LIMITS OF PEAK TO AVERAGE RATIO MEASUREMENT

In measuring transmissions in this band using an average power technique, the peak to-average ratio (PAR) of the transmission may not exceed 13 dB.

4.4.2 TEST INSTRUMENTS

DESCRIPTION & MANUFACTURER	MODEL NO.	SERIAL NO.	DATE OF CALIBRATION	DUE DATE OF CALIBRATION
* Mini-Circuits Power Splitter	ZN2PD-9G	NA	May 25, 2011	May 24, 2012
* Hewlett Packard RF cable	8120-6192	01428251	NA	NA
* JFW 20dB attenuation	50HF-020-SMA	NA	NA	NA
* Suhner RF cable	SUCOFLEX 104	274403/4	Jan. 07, 2011	Jan. 06, 2012
* ROHDE & SCHWARZ Spectrum Analyzer	FSP40	100039	Jan. 11, 2011	Jan. 10, 2012

NOTE: The calibration interval of the above test instruments is 12 months and the calibrations are traceable to NML/ROC and NIST/USA.

4.4.3 TEST PROCEDURES

1. Set resolution/measurement bandwidth \geq signal's occupied bandwidth;
2. Set the number of counts to a value that stabilizes the measured CCDF curve;
3. Record the maximum PAPR level associated with a probability of 0.1%.

4.4.4 TEST SETUP

Same as Item 4.2.4 (Conducted Power Setup)

4.4.5 EUT OPERATING CONDITION

Same as Item 4.1.5

4.4.6 TEST RESULTS

QPSK

FREQUENCY (MHz)	PEAK TO AVERAGE RATIO (dB)			
	1RB LOWER	1RB UPPER	50% RB	100% RB
782.0	3.56	3.44	5.40	5.30

50%RB

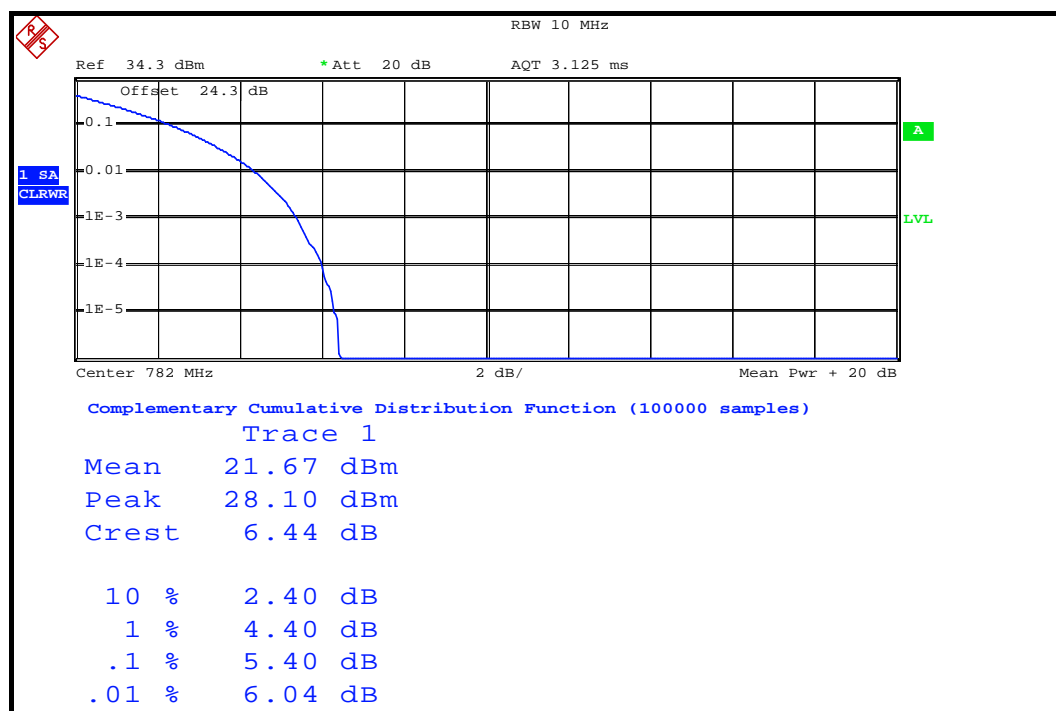

16QAM

FREQUENCY (MHz)	PEAK TO AVERAGE RATIO (dB)			
	1RB LOWER	1RB UPPER	50% RB	100% RB
782.0	4.24	4.16	6.00	6.24

100%RB

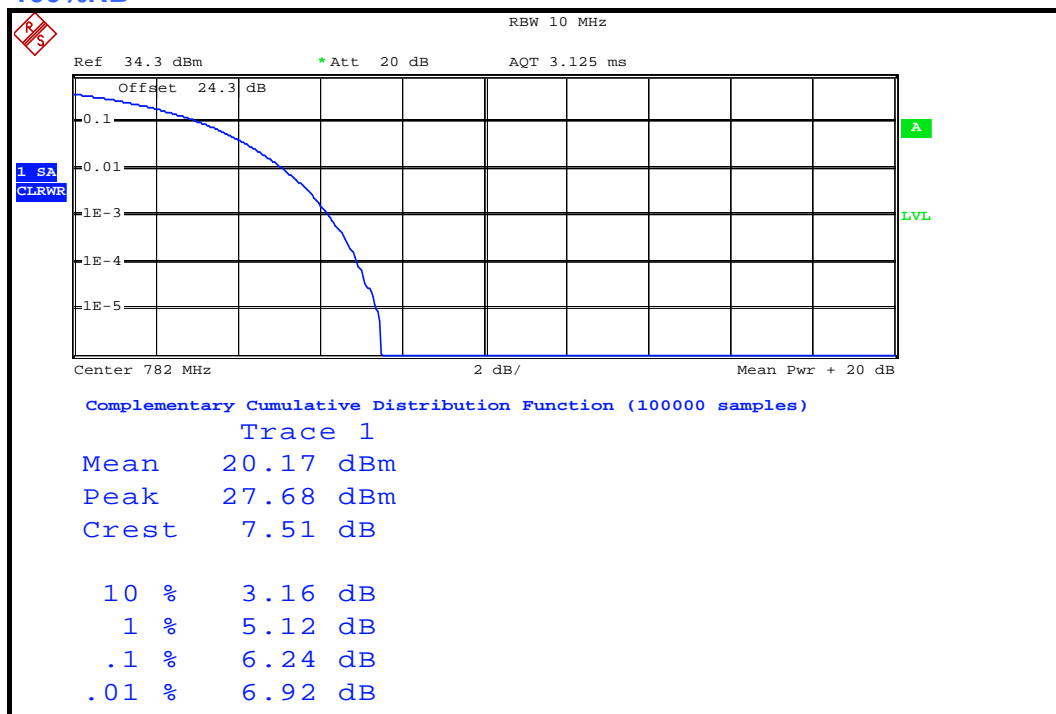



4.5 BAND EDGE MEASUREMENT

4.5.1 LIMITS OF BAND EDGE MEASUREMENT

On any frequency outside the 777–787 MHz band, the power of any emission shall be attenuated outside the band below the transmitter power (P) by at least $43 + 10 \log (P)$ dB.

4.5.2 TEST INSTRUMENTS

DESCRIPTION & MANUFACTURER	MODEL NO.	SERIAL NO.	DATE OF CALIBRATION	DUE DATE OF CALIBRATION
Mini-Circuits Power Splitter	ZN2PD-9G	NA	May 25, 2011	May 24, 2012
Hewlett Packard RF cable	8120-6192	01428251	NA	NA
JFW 20dB attenuation	50HF-020-SMA	NA	NA	NA
Suhner RF cable	SUCOFLEX 104	274403/4	Jan. 07, 2011	Jan. 06, 2012
* ROHDE & SCHWARZ Spectrum Analyzer	FSP40	100039	Jan. 11, 2011	Jan. 10, 2012

NOTE: The calibration interval of the above test instruments is 12 months and the calibrations are traceable to NML/ROC and NIST/USA.

4.5.3 TEST PROCEDURES

- a. The EUT was set up for the maximum peak power with LTE link data modulation. The power was measured with Agilent Spectrum Analyzer. All measurements were done at specific channel.
- b. The band edge measurement used the power splitter via EUT RF power connector between simulator and spectrum analyzer.
- c. RB of the spectrum is 100kHz and VB of the spectrum is 300kHz.
- d. Record the max trace plot into the test report.

4.5.4 TEST SETUP

Same as Item 4.1.4 (Conducted Power Setup)

4.5.5 EUT OPERATING CONDITIONS

Same as 4.1.5.

4.5.6 TEST RESULTS

1RB ALLOCATED AT THE LOWER EDGE:

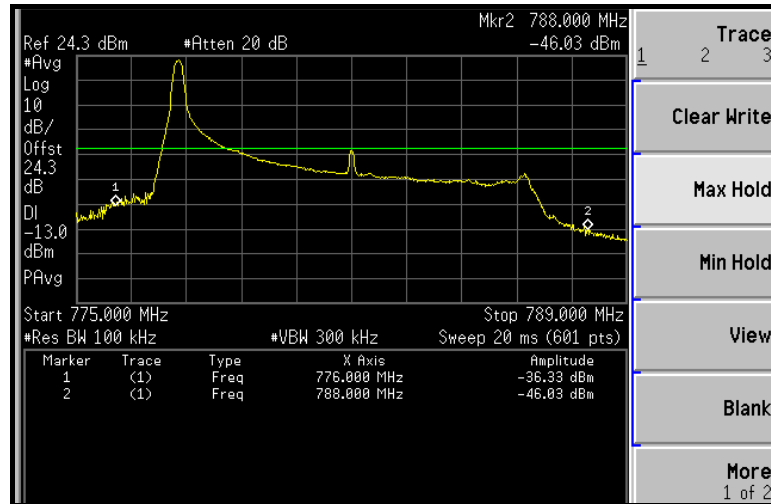

1RB ALLOCATED AT THE UPPER EDGE

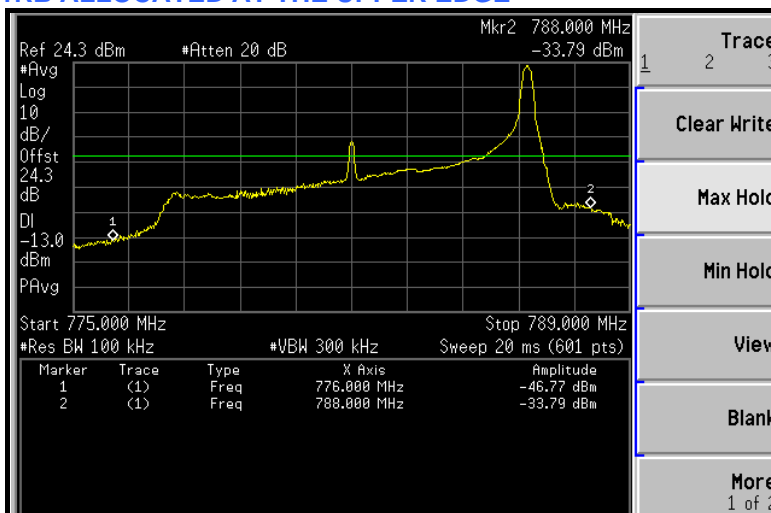

100% RB ALLOCATED

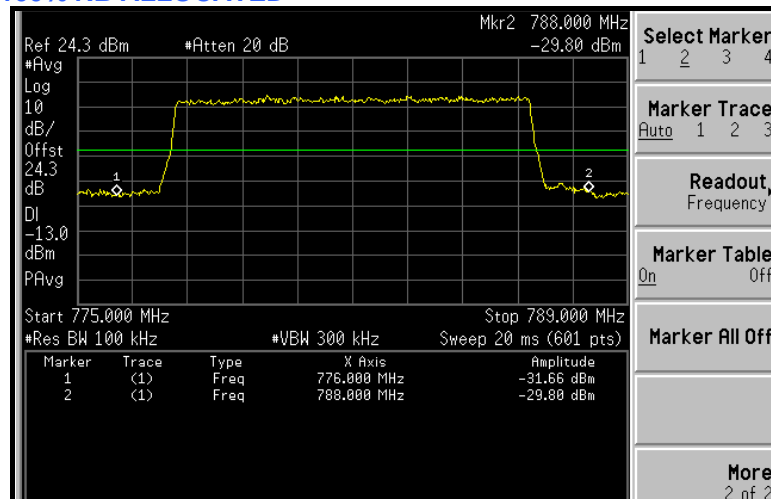



4.6 CONDUCTED SPURIOUS EMISSIONS

4.6.1 LIMITS OF CONDUCTED SPURIOUS EMISSIONS MEASUREMENT

The power of any emission outside a licensee's frequency block shall be attenuated below the transmitter power (P) by at least $43 + 10 \log_{10}(P)$ dB. The limit of emission equal to -13 dBm.

On all frequencies between 763–775 MHz and 793–805 MHz, by a factor not less than $65 + 10 \log (P)$ dB in a 6.25 kHz band segment, for mobile and portable stations.

4.6.2 TEST INSTRUMENTS

DESCRIPTION & MANUFACTURER	MODEL NO.	SERIAL NO.	DATE OF CALIBRATION	DUE DATE OF CALIBRATION
Mini-Circuits Power Splitter	ZAPD-4	NA	Mar. 24, 2011	Mar. 23, 2012
Hewlett Packard RF cable	8120-6192	01428251	NA	NA
JFW 20dB attenuation	50HF-020-SMA	NA	NA	NA
Suhner RF cable	SUCOFLEX 104	257029	Jan. 07, 2011	Jan. 06, 2012
ROHDE & SCHWARZ Spectrum Analyzer	FSP40	100039	Feb. 23, 2011	Feb. 22, 2012
Wainwright Instruments Band Reject Filter	WRCG1850/1910-1 830/1930-60/10SS	SN1	Mar. 23, 2011	Mar. 22, 2012
Wainwright Instruments High Pass Filter	WHK3.1/18G-10SS	SN3	Mar. 23, 2011	Mar. 22, 2012

NOTE: The calibration interval of the above test instruments is 12 months and the calibrations are traceable to NML/ROC and NIST/USA.

4.6.3 TEST PROCEDURE

- a. The EUT was set up for the maximum peak power with LTE link data modulation. The power was measured with Angilent Spectrum Analyzer. All measurements were done at specific channel.
- b. The conducted spurious emission used the power splitter via EUT RF power connector between signal generator and spectrum analyzer.
- c. EUT connected to spectrum analyzer with a 20 dB pad.
- d. RBW=1MHz and VBW=3MHz is used for measuring emission from 30MHz to 8GHz.
- e. RBW=10kHz and VBW=30kHz is used for measuring emission form 763~775 and 793~805MHz

4.6.4 TEST SETUP

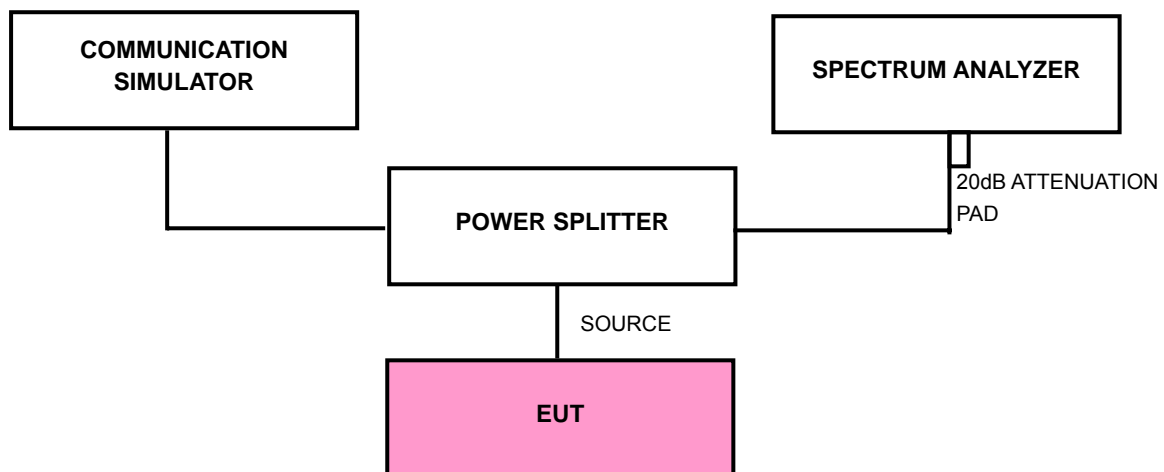

4.6.5 EUT OPERATING CONDITIONS

Same as 4.1.5.

4.6.6 TEST RESULTS

1 RB ALLOCATED AT THE UPPER EDGE 30MHz ~ 2GHz

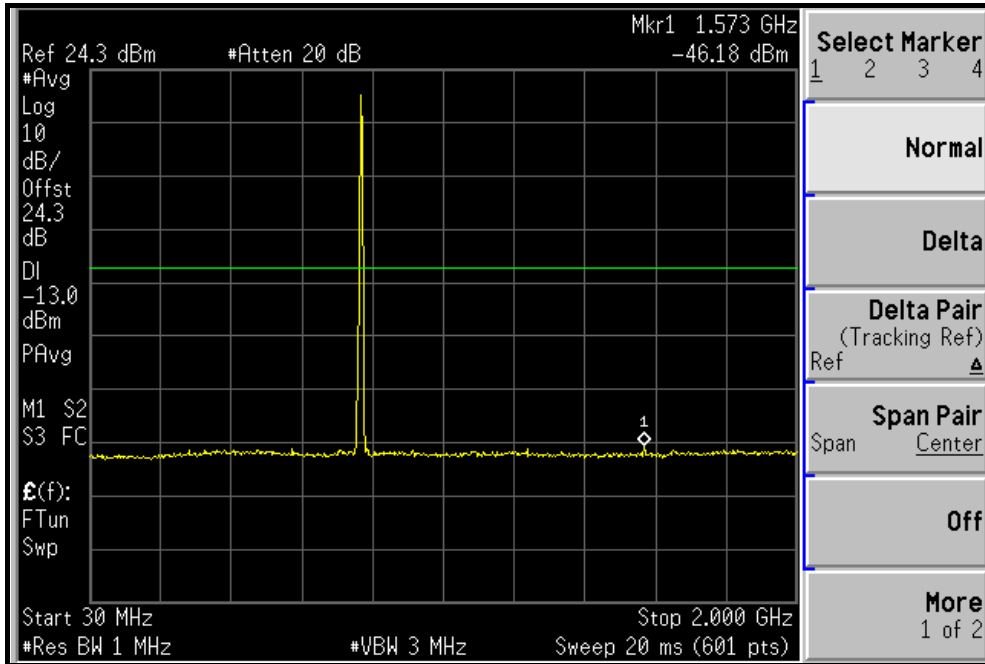

2GHz ~ 8GHz

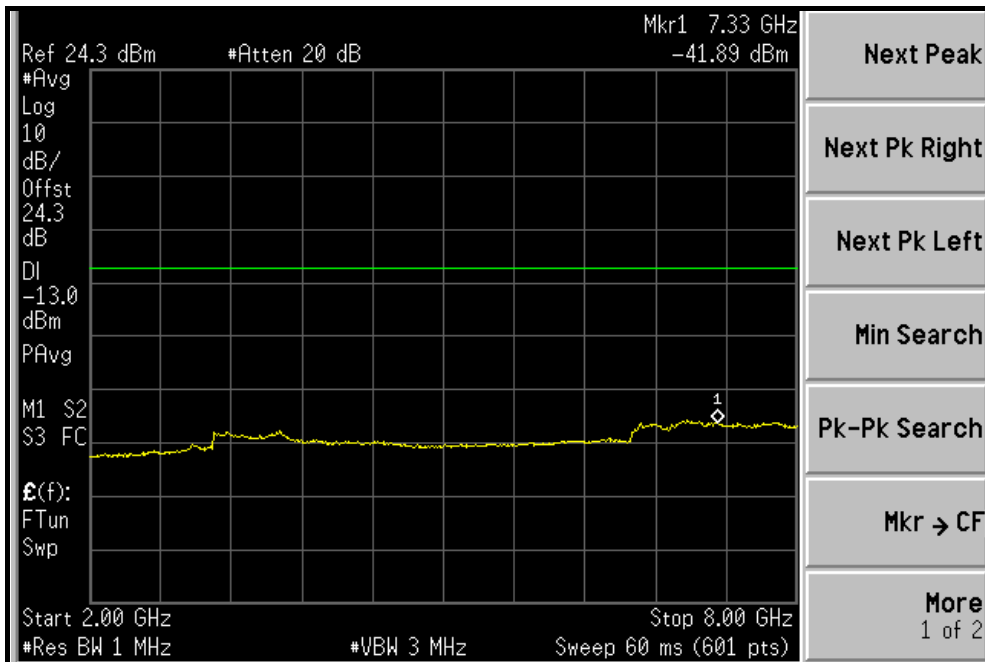

Emission in the 763–775 MHz band
1 RB ALLOCATED AT THE LOWER EDGE

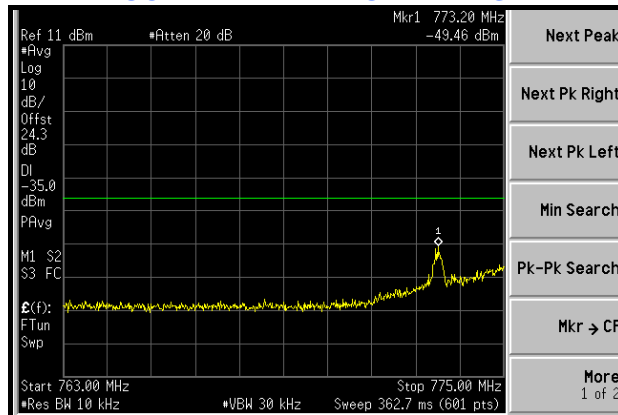

1 RB ALLOCATED AT THE UPPER EDGE

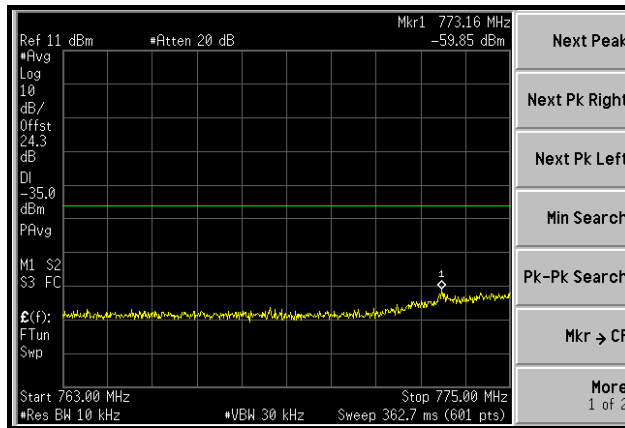

100% RB ALLOCATED

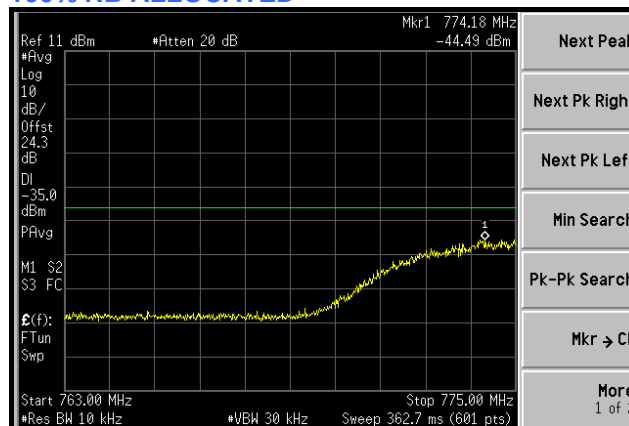

Emission in the 793–805 MHz band
1 RB ALLOCATED AT THE LOWER EDGE

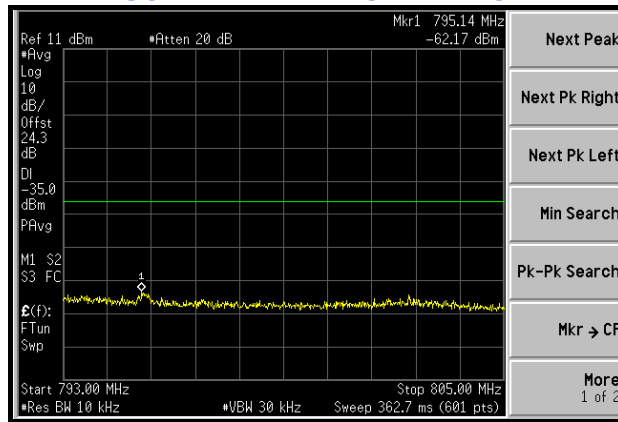

1 RB ALLOCATED AT THE UPPER EDGE

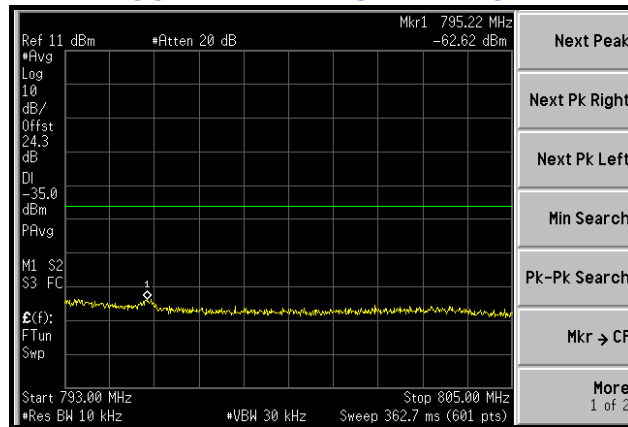

100% RB ALLOCATED

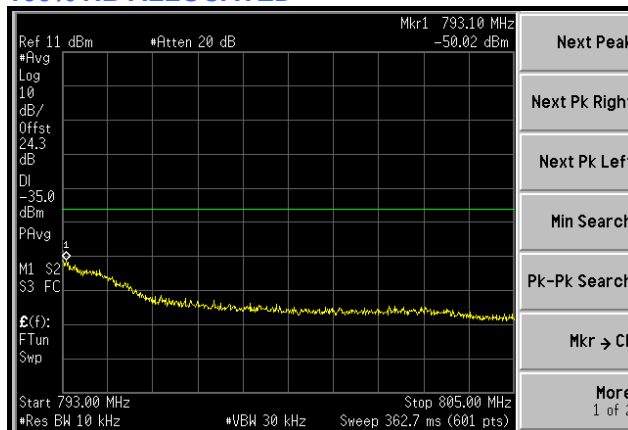

4.7 RADIATED EMISSION MEASUREMENT

4.7.1 LIMITS OF RADIATED EMISSION MEASUREMENT

The power of any emission outside a licensee's frequency block shall be attenuated below the transmitter power (P) by at least $43 + 10 \log_{10}(P)$ dB. The limit of emission equal to -13dBm

4.7.2 TEST INSTRUMENTS

Same as 4.1.2.

4.7.3 TEST PROCEDURES

- a. The EUT was placed on the top of a rotating table 0.8 meters above the ground. The table was rotated 360 degrees to determine the position of the highest radiation.
- b. The EUT was set 3 meters away from the receiving antenna, which was mounted on antenna tower and its position at 0.8 m above the ground.
- c. For each suspected emission, the EUT was arranged to its worst case and the rotatable table was turned from 0 degrees to 360 degrees to find the maximum reading and recorded the value.
- d. Repeat step a ~ c for horizontal polarization.

NOTE: The resolution bandwidth of spectrum analyzer is 1 MHz and the video bandwidth is 3 MHz.

4.7.4 TEST SETUP

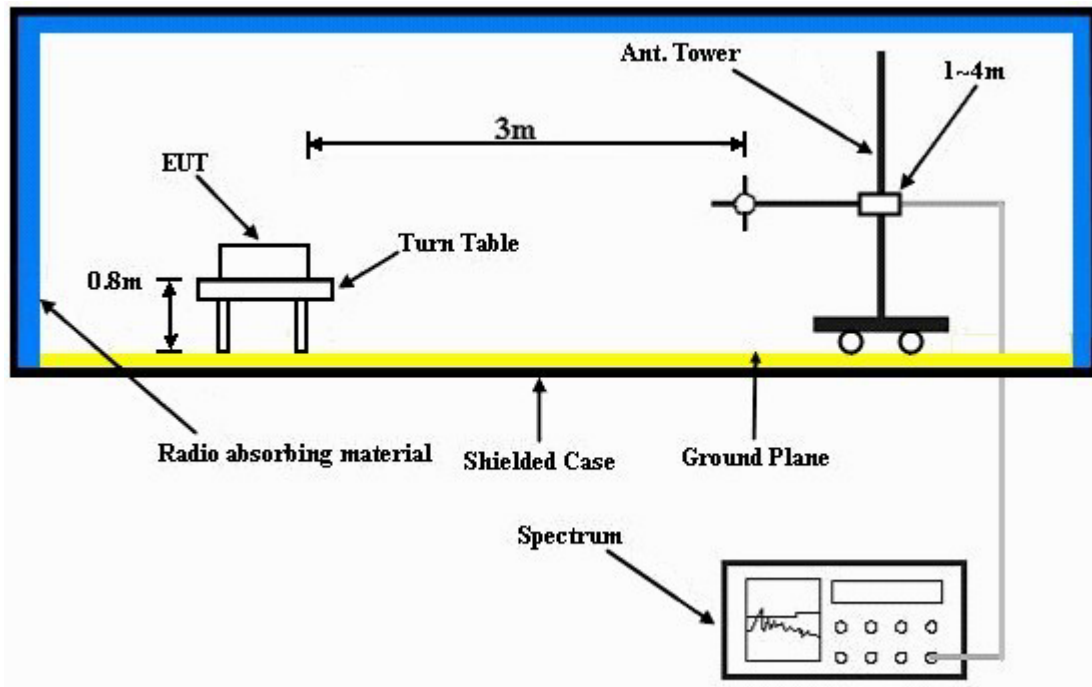

For the actual test configuration, please refer to the attached file (Test Setup Photo).

4.7.5 DEVIATION FROM TEST STANDARD

No deviation

4.7.6 EUT OPERATING CONDITIONS

Same as 4.1.5.



4.7.7 TEST RESULTS

FOR OUTBAND EMISSION

WORST AT QPSK, 1RB ALLOCATED AT THE UPPER EDGE

BELOW 1GHz DATA:

ANTENNA POLARITY & TEST DISTANCE: HORIZONTAL AT 3m							
NO.	FREQ. (MHz)	READING (dBm)	S.G POWER VALUE (dBm)	CORRECTION FACTOR (dB)	ERP (dBm)	LIMIT (dBm)	MARGIN (dB)
1	31.94	-60.0	-43.6	-12.4	-58.1	-13.0	-45.1
2	96.09	-55.4	-63.2	1.0	-64.4	-13.0	-51.4
3	144.69	-59.4	-63.9	-0.2	-66.2	-13.0	-53.2
4	255.49	-66.5	-76.8	5.4	-73.6	-13.0	-60.6
5	589.84	-43.6	-47.0	4.5	-44.6	-13.0	-31.6
6	965.01	-68.4	-65.1	3.9	-63.4	-13.0	-50.4
ANTENNA POLARITY & TEST DISTANCE: VERTICAL AT 3m							
NO.	FREQ. (MHz)	READING (dBm)	S.G POWER VALUE (dBm)	CORRECTION FACTOR (dB)	ERP (dBm)	LIMIT (dBm)	MARGIN (dB)
1	33.89	-49.2	-43.8	-12.1	-58.0	-13.0	-45.0
2	78.60	-56.2	-58.8	-2.1	-63.0	-13.0	-50.0
3	226.33	-56.1	-63.8	5.4	-60.5	-13.0	-47.5
4	414.89	-60.7	-64.5	5.2	-61.4	-13.0	-48.4
5	589.84	-42.7	-43.4	4.5	-41.0	-13.0	-28.0
6	700.64	-62.5	-61.3	5.2	-58.2	-13.0	-45.2

NOTE: ERP(dBm) = S.G Power Value (dBm) + Correction Factor (dB).
Correction Factor = gain of substitution antenna + cable loss



A D T

ABOVE 1GHz DATA:

ANTENNA POLARITY & TEST DISTANCE: HORIZONTAL AT 3m							
NO.	FREQ. (MHz)	READING (dB-m)	S.G POWER VALUE (dBm)	CORRECTION FACTOR (dB)	ERP (dBm)	LIMIT (dBm)	MARGIN (dB)
1	2359.20	-54.3	-52.3	6.4	-48.0	-13.0	-35.0
2	3145.60	-68.4	-64.3	6.6	-59.9	-13.0	-46.9
3	3932.00	-67.0	-62.0	7.0	-57.1	-13.0	-44.1

ANTENNA POLARITY & TEST DISTANCE: VERTICAL AT 3m							
NO.	FREQ. (MHz)	READING (dBm)	S.G POWER VALUE (dBm)	CORRECTION FACTOR (dB)	ERP (dBm)	LIMIT (dBm)	MARGIN (dB)
1	2359.20	-52.1	-49.6	6.4	-45.4	-13.0	-32.4
2	3145.60	-67.7	-64.5	6.6	-60.0	-13.0	-47.0
3	3932.00	-66.1	-61.8	7.0	-56.9	-13.0	-43.9

NOTE: ERP(dBm) = S.G Power Value (dBm) + Correction Factor (dB).
Correction Factor = gain of substitution antenna + cable loss

Emissions in the band 1559–1610 MHz

FOR GPS BAND EMISSION

WORST AT QPSK, 1RB ALLOCATED AT THE UPPER EDGE

ANTENNA POLARITY & TEST DISTANCE: HORIZONTAL AT 3m							
NO.	FREQ. (MHz)	READING (dB-m)	S.G POWER VALUE (dBm)	CORRECTION FACTOR (dB)	EIRP (dBm)	LIMIT (dBm)	MARGIN (dB)
1	1572.8	-47.7	-48.0	5.3	-42.7	-40.0	-2.7

NO.	FREQ. (MHz)	READING (dBm)	S.G POWER VALUE (dBm)	CORRECTION FACTOR (dB)	EIRP (dBm)	LIMIT (dBm)	MARGIN (dB)
1	1572.8	50.0	52.4	5.3	-47.1	-40.0	-7.1

NOTE: ERP(dBm) = S.G Power Value (dBm) + Correction Factor (dB).
Correction Factor = gain of substitution antenna + cable loss



5 INFORMATION ON THE TESTING LABORATORIES

We, Bureau Veritas Consumer Products Services (H.K.) Ltd., Taoyuan Branch, were founded in 1988 to provide our best service in EMC, Radio, Telecom and Safety consultation. Our laboratories are accredited and approved according to ISO/IEC 17025.

Copies of accreditation and authorization certificates of our laboratories obtained from approval agencies can be downloaded from our web site: www.adt.com.tw/index.5.phtml. If you have any comments, please feel free to contact us at the following:

Linko EMC/RF Lab:
Tel: 886-2-26052180
Fax: 886-2-26051924

Hsin Chu EMC/RF Lab:
Tel: 886-3-5935343
Fax: 886-3-5935342

Hwa Ya EMC/RF/Safety/Telecom Lab:
Tel: 886-3-3183232
Fax: 886-3-3185050

Email: service.adt@tw.bureauveritas.com
Web Site: www.adt.com.tw

The address and road map of all our labs can be found in our web site also.



6 APPENDIX A – MODIFICATIONS RECORDERS FOR ENGINEERING CHANGES TO THE EUT BY THE LAB

No any modifications are made to the EUT by the lab during the test.

---END---