

TEST REPORT

CERTIFICATE OF CONFORMITY

Standard: 47 CFR FCC Part 22
47 CFR FCC Part 27
47 CFR FCC Part 90
47 CFR FCC Part 2

Report No.: RFBCKS-WTW-P23060549

FCC ID: NKR-VMC-9628RV1

Product: 2G/3G/4G Module

Brand: WNC

Model No.: VMC-9628RV1

Received Date: 2023/6/21

Test Date: 2023/7/5~2023/7/20

Issued Date: 2023/9/28

Applicant: Wistron NeWeb Corporation

Address: 20 Park Ave. II, Hsinchu Science Park, Hsinchu 308, Taiwan

Issued By: Bureau Veritas Consumer Products Services (H.K.) Ltd., Taoyuan Branch
Lin Kou Laboratories

Lab Address: No. 47-2, 14th Ling, Chia Pau Vil., Lin Kou Dist., New Taipei City, Taiwan

Test Location: No. 19, Hwa Ya 2nd Rd., Wen Hwa Vil., Kwei Shan Dist., Taoyuan City 33383, TAIWAN

FCC Registration / 788550 / TW0003

Designation Number:

Approved by: _____

Jeremy Lin

Date: _____

2023/9/28

Jeremy Lin / Project Engineer

This test report consists of 271 pages in total. It may be duplicated completely for legal use with the approval of the applicant. It should not be reproduced except in full, without the written approval of our laboratory. The test results in the report only apply to the tested sample. The test results in this report are traceable to the national or international standards.



Prepared by : Polly Chien / Specialist

This report is governed by, and incorporates by reference, the Conditions of Testing as posted at the date of issuance of this report at <http://www.bureauveritas.com/home/about-us/our-business/cps/about-us/terms-conditions/> and is intended for your exclusive use. Any copying or replication of this report to or for any other person or entity, or use of our name or trademark, is permitted only with our prior written permission. This report sets forth our findings solely with respect to the test samples identified herein. The results set forth in this report are not indicative or representative of the quality or characteristics of the lot from which a test sample was taken or any similar or identical product unless specifically and expressly noted. Our report includes all of the tests requested by you and the results thereof based upon the information that you provided to us. Measurement uncertainty is only provided upon request for accredited tests. Statements of conformity are based on simple acceptance criteria without taking measurement uncertainty into account, unless otherwise requested in writing. You have 60 days from date of issuance of this report to notify us of any material error or omission caused by our negligence or if you require measurement uncertainty; provided, however, that such notice shall be in writing and shall specifically address the issue you wish to raise. A failure to raise such issue within the prescribed time shall constitute your unqualified acceptance of the completeness of this report, the tests conducted and the correctness of the report contents.

Table of Contents

Release Control Record	5
1 Certificate	6
2 Summary of Test Results	7
2.1 Measurement Uncertainty	8
2.2 Supplementary Information	8
3 General Information	9
3.1 General Description of EUT	9
3.2 Antenna Description of EUT	11
3.3 Test Mode Applicability and Tested Channel Detail	12
3.4 Test Program Used and Operation Descriptions	24
3.5 Connection Diagram of EUT and Peripheral Devices	24
3.6 Configuration of Peripheral Devices and Cable Connections	24
4 Test Instruments	25
4.1 Effective Radiated Power and Equivalent Isotropically Radiated Power	25
4.2 Modulation Characteristics	25
4.3 Peak to Average Ratio	25
4.4 Bandwidth	25
4.5 Conducted Spurious Emissions	25
4.6 Radiated Spurious Emissions below 1GHz	26
4.7 Radiated Spurious Emissions above 1GHz	27
4.8 Frequency Stability	28
5 Limits of Test Items	29
5.1 Effective Radiated Power and Equivalent Isotropically Radiated Power	29
5.2 Modulation Characteristics	29
5.3 Peak to Average Ratio	29
5.4 Bandwidth	29
5.5 Conducted Spurious Emissions	30
5.6 Radiated Spurious Emissions below 1GHz	30
5.7 Radiated Spurious Emissions above 1GHz	31
5.8 Frequency Stability	31
6 Test Arrangements	32
6.1 Effective Radiated Power and Equivalent Isotropically Radiated Power	32
6.1.1 Test Setup	32
6.1.2 Test Procedure	32
6.2 Modulation Characteristics	33
6.2.1 Test Setup	33
6.2.2 Test Procedure	33
6.3 Peak to Average Ratio	33
6.3.1 Test Setup	33
6.3.2 Test Procedure	33
6.4 Bandwidth	34
6.4.1 Test Setup	34
6.4.2 Test Procedure	34
6.5 Conducted Spurious Emissions	36
6.5.1 Test Setup	36
6.5.2 Test Procedure	36
6.6 Radiated Spurious Emissions below 1GHz	37
6.6.1 Test Setup	37
6.6.2 Test Procedure	37
6.7 Radiated Spurious Emissions above 1GHz	38
6.7.1 Test Setup	38
6.7.2 Test Procedure	38
6.8 Frequency Stability	39
6.8.1 Test Setup	39



6.8.2	Test Procedure.....	39
7	Test Results of Test Item.....	40
7.1	Effective Radiated Power and Equivalent Isotropically Radiated Power.....	40
7.1.1	WCDMA Band 5.....	40
7.1.2	LTE Band 5.....	41
7.1.3	LTE Band 7.....	45
7.1.4	LTE Band 26 (Part 22).....	49
7.1.5	LTE Band 26 (Part 90).....	55
7.1.6	LTE Band 38.....	59
7.1.7	LTE Band 41.....	63
7.2	Modulation Characteristics.....	67
7.2.1	WCDMA Band 5.....	67
7.2.2	LTE Band 5.....	68
7.2.3	LTE Band 7.....	69
7.2.4	LTE Band 26 (Part 22).....	70
7.2.5	LTE Band 26 (Part 90).....	71
7.2.6	LTE Band 38.....	72
7.2.7	LTE Band 41.....	73
7.3	Peak to Average Ratio.....	74
7.3.1	WCDMA Band 5.....	74
7.3.2	LTE Band 5.....	75
7.3.3	LTE Band 7.....	79
7.3.4	LTE Band 26 (Part 22).....	83
7.3.5	LTE Band 38.....	88
7.3.6	LTE Band 41.....	92
7.4	Bandwidth.....	96
7.4.1	WCDMA Band 5.....	96
7.4.2	LTE Band 5.....	97
7.4.3	LTE Band 7.....	101
7.4.4	LTE Band 26 (Part 22).....	105
7.4.5	LTE Band 26 (Part 90).....	110
7.4.6	LTE Band 38.....	114
7.4.7	LTE Band 41.....	118
7.5	Conducted Spurious Emissions.....	122
7.5.1	WCDMA Band 5.....	122
7.5.2	LTE Band 5.....	128
7.5.3	LTE Band 7.....	136
7.5.4	LTE Band 26 (Part 22).....	144
7.5.5	LTE Band 26 (Part 90).....	154
7.5.6	LTE Band 38.....	168
7.5.7	LTE Band 41.....	176
7.6	Radiated Spurious Emissions below 1GHz.....	184
7.6.1	WCDMA Band 5.....	184
7.6.2	LTE Band 5.....	186
7.6.3	LTE Band 7.....	188
7.6.4	LTE Band 26 (Part 22).....	190
7.6.5	LTE Band 26 (Part 90).....	192
7.6.6	LTE Band 38.....	194
7.6.7	LTE Band 41.....	196
7.7	Radiated Spurious Emissions above 1GHz.....	198
7.7.1	WCDMA Band 5.....	198
7.7.2	LTE Band 5.....	201
7.7.3	LTE Band 7.....	210
7.7.4	LTE Band 26 (Part 22).....	216
7.7.5	LTE Band 26 (Part 90).....	225
7.7.6	LTE Band 38.....	232
7.7.7	LTE Band 41.....	238
7.8	Frequency Stability.....	244
7.8.1	WCDMA Band 5.....	244
7.8.2	LTE Band 5.....	245



7.8.3	LTE Band 7	249
7.8.4	LTE Band 26 (Part 22)	253
7.8.5	LTE Band 26 (Part 90)	258
7.8.6	LTE Band 38	262
7.8.7	LTE Band 41	266
8	Pictures of Test Arrangements	270
9	Information of the Testing Laboratories	271

Release Control Record

Issue No.	Description	Date Issued
RFBCKS-WTW-P23060549	Original release.	2023/9/28

1 Certificate

Product: 2G/3G/4G Module

Brand: WNC

Test Model: VMC-9628RV1

Sample Status: Engineering sample

Applicant: Wistron NeWeb Corporation

Test Date: 2023/7/5~2023/7/20

Standard: 47 CFR FCC Part 22
47 CFR FCC Part 27
47 CFR FCC Part 90
47 CFR FCC Part 2

Measurement ANSI/TIA/EIA-603-E 2016

procedure: ANSI C63.26-2015

KDB 971168 D01 Power Meas License Digital Systems v03r01

KDB 971168 D02 Misc Rev Approv License Devices v02r02

The above equipment has been tested by **Bureau Veritas Consumer Products Services (H.K.) Ltd., Taoyuan Branch**, and found compliance with the requirement of the above standards. The test record, data evaluation & Equipment Under Test (EUT) configurations represented herein are true and accurate accounts of the measurements of the sample's RF characteristics under the conditions specified in this report.

2 Summary of Test Results

47 CFR FCC Part 22 47 CFR FCC Part 27 47 CFR FCC Part 90 47 CFR FCC Part 2			
Standard / Clause	Test Item	Result	Remark
FCC 47 CFR Part 2.1046 FCC 47 CFR Part 22.913 (a) FCC 47 CFR Part 27.50(d) FCC 47 CFR Part 27.50(h) FCC 47 CFR Part 27.50(c) FCC 47 CFR Part 27.50(b) FCC 47 CFR Part 27.50(a) FCC 47 CFR Part 90.635(b)	Effective Radiated Power and Equivalent Isotropically Radiated Power	Pass	Meet the requirement of limit.
FCC 47 CFR Part 2.1047	Modulation Characteristics	Pass	Meet the requirement of limit.
FCC 47 CFR Part 22.913 (d) FCC 47 CFR Part 27.50(d)	Peak to Average Ratio	Pass	Meet the requirement of limit.
FCC 47 CFR Part 2.1049	Bandwidth	Pass	Meet the requirement of limit.
FCC 47 CFR Part 2.1051 FCC 47 CFR Part 22.917 FCC 47 CFR Part 27.53(h) FCC 47 CFR Part 27.53(m) FCC 47 CFR Part 27.53(g) FCC 47 CFR Part 27.53(c)(f) FCC 47 CFR Part 27.53(a) FCC 47 CFR Part 90.691	Conducted Spurious Emissions	Pass	Meet the requirement of limit.
FCC 47 CFR Part 2.1053 FCC 47 CFR Part 22.917 FCC 47 CFR Part 27.53(h) FCC 47 CFR Part 27.53(m) FCC 47 CFR Part 27.53(g) FCC 47 CFR Part 27.53(c)(f) FCC 47 CFR Part 27.53(a) FCC 47 CFR Part 90.691	Radiated Spurious Emissions below 1GHz	Pass	Minimum passing margin is -12.19 dB at 41.25 MHz
FCC 47 CFR Part 2.1053 FCC 47 CFR Part 22.917 FCC 47 CFR Part 27.53(h) FCC 47 CFR Part 27.53(m) FCC 47 CFR Part 27.53(g) FCC 47 CFR Part 27.53(c)(f) FCC 47 CFR Part 27.53(a) FCC 47 CFR Part 90.691	Radiated Spurious Emissions above 1GHz	Pass	Minimum passing margin is -14.15 dB at 5190.00 MHz
FCC 47 CFR Part 2.1055 FCC 47 CFR Part 22.355 FCC 47 CFR Part 27.54 FCC 47 CFR Part 90.231	Frequency Stability	Pass	Meet the requirement of limit.

Note: Determining compliance based on the results of the compliance measurement, not taking into account measurement instrumentation uncertainty.

2.1 Measurement Uncertainty

Where relevant, the following measurement uncertainty levels have been estimated for tests performed on the EUT as specified in CISPR 16-4-2:

Measurement	Specification	Expanded Uncertainty (k=2) (±)
Radiated Spurious Emissions below 1GHz	9 kHz ~ 30 MHz	3.59 dB
	30 MHz ~ 1 GHz	3.64 dB
Radiated Spurious Emissions above 1GHz	1 GHz ~ 18 GHz	2.29 dB
	18 GHz ~ 40 GHz	2.29 dB

The other instruments specified are routine verified to remain within the calibrated levels, no measurement uncertainty is required to be calculated.

2.2 Supplementary Information

There is not any deviation from the test standards for the test method, and no modifications required for compliance.

3 General Information

3.1 General Description of EUT

Product	2G/3G/4G Module
Brand	WNC
Test Model	VMC-9628RV1
Status of EUT	Engineering sample
Power Supply Rating	3.8Vdc (From DC power supply or host)

Note:

1. EUT Overview

Band / Bandwidth	TX Frequency Range (MHz)	Max. ERP Power	Emission Designator
WCDMA Band 5	826.4-846.6	216.272mW(23.35dBm)	4M14F9W

Band / Bandwidth	TX Frequency Range (MHz)	Max. EIRP Power		Emission Designator	
		QPSK	16QAM	QPSK	16QAM
LTE Band 7 (Channel Bandwidth 5MHz)	2502.5-2567.5	299.916mW (24.77dBm)	242.661mW (23.85dBm)	4M50G7D	4M49D7W
LTE Band 7 (Channel Bandwidth 10MHz)	2505.0-2565.0	304.089mW (24.83dBm)	243.220mW (23.86dBm)	8M96G7D	8M95D7W
LTE Band 7 (Channel Bandwidth 15MHz)	2507.5-2562.5	301.995mW (24.80dBm)	244.343mW (23.88dBm)	13M4G7D	13M4D7W
LTE Band 7 (Channel Bandwidth 20MHz)	2510.0-2560.0	306.196mW (24.86dBm)	246.604mW (23.92dBm)	17M9G7D	17M9D7W
LTE Band 38 (Channel Bandwidth 5MHz)	2572.5-2617.5	274.789mW (24.39dBm)	221.309mW (23.45dBm)	4M50G7D	4M49D7W
LTE Band 38 (Channel Bandwidth 10MHz)	2575.0-2615.0	275.423mW (24.40dBm)	222.331mW (23.47dBm)	8M95G7D	8M95D7W
LTE Band 38 (Channel Bandwidth 15MHz)	2577.5-2612.5	277.971mW (24.44dBm)	226.986mW (23.56dBm)	13M4G7D	13M4D7W
LTE Band 38 (Channel Bandwidth 20MHz)	2580.0-2610.0	289.068mW (24.61dBm)	234.963mW (23.71dBm)	17M9G7D	17M9D7W
LTE Band 41 (Channel Bandwidth 5MHz)	2557.5-2652.5	263.633mW (24.21dBm)	212.324mW (23.27dBm)	4M50G7D	4M49D7W
LTE Band 41 (Channel Bandwidth 10MHz)	2560.0-2650.0	269.153mW (24.30dBm)	220.293mW (23.43dBm)	8M96G7D	8M96D7W
LTE Band 41 (Channel Bandwidth 15MHz)	2562.5-2647.5	262.422mW (24.19dBm)	213.796mW (23.30dBm)	13M4G7D	13M4D7W
LTE Band 41 (Channel Bandwidth 20MHz)	2565.0-2645.0	269.774mW (24.31dBm)	219.786mW (23.42dBm)	17M9G7D	17M9D7W

Band / Bandwidth		TX Frequency Range (MHz)	Max. ERP Power		Emission Designator	
			QPSK	16QAM	QPSK	16QAM
LTE Band 5 (Channel Bandwidth 1.4MHz)		824.7-848.3	236.048mW (23.73dBm)	191.426mW (22.82dBm)	1M09G7D	1M09D7W
LTE Band 5 (Channel Bandwidth 3MHz)		825.5-847.5	236.048mW (23.73dBm)	189.671mW (22.78dBm)	2M70G7D	2M70D7W
LTE Band 5 (Channel Bandwidth 5MHz)		826.5-846.5	237.137mW (23.75dBm)	192.309mW (22.84dBm)	4M50G7D	4M49D7W
LTE Band 5 (Channel Bandwidth 10MHz)		829.0-844.0	238.232mW (23.77dBm)	192.752mW (22.85dBm)	8M96G7D	8M97D7W
For Part 22	LTE Band 26 (Channel Bandwidth 1.4MHz)	824.7-848.3	215.774mW (23.34dBm)	175.792mW (22.45dBm)	1M09G7D	1M09D7W
	LTE Band 26 (Channel Bandwidth 3MHz)	825.5-847.5	216.272mW (23.35dBm)	177.011mW (22.48dBm)	2M70G7D	2M70D7W
	LTE Band 26 (Channel Bandwidth 5MHz)	826.5-846.5	220.800mW (23.44dBm)	178.238mW (22.51dBm)	4M50G7D	4M49D7W
	LTE Band 26 (Channel Bandwidth 10MHz)	829.0-844.0	218.776mW (23.40dBm)	178.649mW (22.52dBm)	8M96G7D	8M96D7W
	LTE Band 26 (Channel Bandwidth 15MHz)	831.5-841.5	218.776mW (23.40dBm)	177.419mW (22.49dBm)	13M4G7D	13M4D7W
For Part 90	LTE Band 26 (Channel Bandwidth 1.4MHz)	814.7-823.3	215.278mW (23.33dBm)	176.198mW (22.46dBm)	1M09G7D	1M09D7W
	LTE Band 26 (Channel Bandwidth 3MHz)	815.5-822.5	214.783mW (23.32dBm)	175.792mW (22.45dBm)	2M70G7D	2M70D7W
	LTE Band 26 (Channel Bandwidth 5MHz)	816.5-821.5	220.293mW (23.43dBm)	177.419mW (22.49dBm)	4M50G7D	4M49D7W
	LTE Band 26 (Channel Bandwidth 10MHz)	819.0	216.770mW (23.36dBm)	173.380mW (22.39dBm)	8M96G7D	8M96D7W

2. The above EUT information is declared by manufacturer and for more detailed features description, please refers to the manufacturer's specifications or user's manual.

3.2 Antenna Description of EUT

1. The antenna information is listed as below.

Antenna Type		Dipole	
Antenna Connector		SMA	
Item	Antenna No.	Band	Gain (dBi)
LTE	ANT1/ ANT2	Band 5	2
		Band 7	2
		Band 26	2
		Band 38	2
		Band 41	2
WCDMA	ANT0	Band 5	2

* The above Antenna information is declared by manufacturer and for more detailed features description, please refer to the manufacturer's specifications, the laboratory shall not be held responsible.

3.3 Test Mode Applicability and Tested Channel Detail

Pre-Scan:	EUT can be used in the following ways: X-axis/ Y-axis/ Z-axis. Pre-scan these ways and find the worst case as a representative test condition.
Worst Case:	X-axis/ Y-axis/ Z-axis Worst Condition: Z-axis

For WCDMA Band 5

Test Item	Tested Channel	Channel Bandwidth	Modulation	Mode
ERP	4132 (826.40 MHz) 4182 (836.40 MHz) 4233 (846.60 MHz)	-	-	WCDMA HSDPA HSUPA
Modulation Characteristics	4182 (836.40 MHz)	-	-	WCDMA HSDPA HSUPA
Frequency Stability	4132 (826.40 MHz) 4233 (846.60 MHz)	-	-	WCDMA
Occupied Bandwidth	4132 (826.40 MHz) 4182 (836.40 MHz) 4233 (846.60 MHz)	-	-	WCDMA HSDPA HSUPA
Peak to Average Ratio	4132 (826.40 MHz) 4182 (836.40 MHz) 4233 (846.60 MHz)	-	-	WCDMA HSDPA HSUPA
Conducted Emission	4132 (826.40 MHz) 4182 (836.40 MHz) 4233 (846.60 MHz)	-	-	WCDMA HSDPA HSUPA
RE Below 1GHz	4233 (846.60 MHz)	-	-	WCDMA
RE Above 1GHz	4132 (826.40 MHz) 4182 (836.40 MHz) 4233 (846.60 MHz)	-	-	WCDMA

For LTE Band 5

Test Item	Tested Channel	Channel Bandwidth	Modulation	Mode
ERP	20407 (824.70 MHz) 20525 (836.50 MHz) 20643 (848.30 MHz)	1.4 MHz	QPSK / 16QAM	1 RB Half RB Full RB
	20415 (825.50 MHz) 20525 (836.50 MHz) 20635 (847.50 MHz)	3 MHz	QPSK / 16QAM	1 RB Half RB Full RB
	20425 (826.50 MHz) 20525 (836.50 MHz) 20625 (846.50 MHz)	5 MHz	QPSK / 16QAM	1 RB Half RB Full RB
	20450 (829.00 MHz) 20525 (836.50 MHz) 20600 (844.00 MHz)	10 MHz	QPSK / 16QAM	1 RB Half RB Full RB
Modulation Characteristics	20525 (836.50 MHz)	10 MHz	QPSK / 16QAM	Full RB
Frequency Stability	20407 (824.70 MHz) 20643 (848.30 MHz)	1.4 MHz	QPSK / 16QAM	Full RB
	20415 (825.50 MHz) 20635 (847.50 MHz)	3 MHz	QPSK	Full RB
	20425 (826.50 MHz) 20625 (846.50 MHz)	5 MHz	QPSK	Full RB
	20450 (829.00 MHz) 20600 (844.00 MHz)	10 MHz	QPSK	Full RB
Occupied Bandwidth	20407 (824.70 MHz) 20525 (836.50 MHz) 20643 (848.30 MHz)	1.4 MHz	QPSK / 16QAM	Full RB
	20415 (825.50 MHz) 20525 (836.50 MHz) 20635 (847.50 MHz)	3 MHz	QPSK / 16QAM	Full RB
	20425 (826.50 MHz) 20525 (836.50 MHz) 20625 (846.50 MHz)	5 MHz	QPSK / 16QAM	Full RB
	20450 (829.00 MHz) 20525 (836.50 MHz) 20600 (844.00 MHz)	10 MHz	QPSK / 16QAM	Full RB
Peak to Average Ratio	20407 (824.70 MHz) 20525 (836.50 MHz) 20643 (848.30 MHz)	1.4 MHz	QPSK / 16QAM	1 RB
	20415 (825.50 MHz) 20525 (836.50 MHz) 20635 (847.50 MHz)	3 MHz	QPSK / 16QAM	1 RB
	20425 (826.50 MHz) 20525 (836.50 MHz) 20625 (846.50 MHz)	5 MHz	QPSK / 16QAM	1 RB
	20450 (829.00 MHz) 20525 (836.50 MHz) 20600 (844.00 MHz)	10 MHz	QPSK / 16QAM	1 RB

Test Item	Tested Channel	Channel Bandwidth	Modulation	Mode
Conducted Emission	20407 (824.70 MHz) 20525 (836.50 MHz) 20643 (848.30 MHz)	1.4 MHz	QPSK	1 RB Full RB
	20415 (825.50 MHz) 20525 (836.50 MHz) 20635 (847.50 MHz)	3 MHz	QPSK	1 RB Full RB
	20425 (826.50 MHz) 20525 (836.50 MHz) 20625 (846.50 MHz)	5 MHz	QPSK	1 RB Full RB
	20450 (829.00 MHz) 20525 (836.50 MHz) 20600 (844.00 MHz)	10 MHz	QPSK	1 RB Full RB
RE Below 1GHz	20525 (836.50 MHz)	10 MHz	QPSK	1 RB
RE Above 1GHz	20407 (824.70 MHz) 20525 (836.50 MHz) 20643 (848.30 MHz)	1.4 MHz	QPSK	1 RB
	20425 (826.50 MHz) 20525 (836.50 MHz) 20625 (846.50 MHz)	5 MHz	QPSK	1 RB
	20450 (829.00 MHz) 20525 (836.50 MHz) 20600 (844.00 MHz)	10 MHz	QPSK	1 RB

For LTE Band 7

Test Item	Tested Channel	Channel Bandwidth	Modulation	Mode
EIRP	20775 (2502.50 MHz) 21100 (2535.00 MHz) 21425 (2567.50 MHz)	5 MHz	QPSK / 16QAM	1 RB Half RB Full RB
	20800 (2505.00 MHz) 21100 (2535.00 MHz) 21400 (2565.00 MHz)	10 MHz	QPSK / 16QAM	1 RB Half RB Full RB
	20825 (2507.50 MHz) 21100 (2535.00 MHz) 21375 (2562.50 MHz)	15 MHz	QPSK / 16QAM	1 RB Half RB Full RB
	20850 (2510.00 MHz) 21100 (2535.00 MHz) 21350 (2560.00 MHz)	20 MHz	QPSK / 16QAM	1 RB Half RB Full RB
Modulation Characteristics	21100 (2535.00 MHz)	20 MHz	QPSK / 16QAM	Full RB
Frequency Stability	20775 (2502.50 MHz) 21425 (2567.50 MHz)	5 MHz	QPSK	Full RB
	20800 (2505.00 MHz) 21400 (2565.00 MHz)	10 MHz	QPSK	Full RB
	20825 (2507.50 MHz) 21375 (2562.50 MHz)	15 MHz	QPSK	Full RB
	20850 (2510.00 MHz) 21350 (2560.00 MHz)	20 MHz	QPSK	Full RB
Occupied Bandwidth	20775 (2502.50 MHz) 21100 (2535.00 MHz) 21425 (2567.50 MHz)	5 MHz	QPSK / 16QAM	Full RB
	20800 (2505.00 MHz) 21100 (2535.00 MHz) 21400 (2565.00 MHz)	10 MHz	QPSK / 16QAM	Full RB
	20825 (2507.50 MHz) 21100 (2535.00 MHz) 21375 (2562.50 MHz)	15 MHz	QPSK / 16QAM	Full RB
	20850 (2510.00 MHz) 21100 (2535.00 MHz) 21350 (2560.00 MHz)	20 MHz	QPSK / 16QAM	Full RB
Peak to Average Ratio	20775 (2502.50 MHz) 21100 (2535.00 MHz) 21425 (2567.50 MHz)	5 MHz	QPSK / 16QAM	1 RB
	20800 (2505.00 MHz) 21100 (2535.00 MHz) 21400 (2565.00 MHz)	10 MHz	QPSK / 16QAM	1 RB
	20825 (2507.50 MHz) 21100 (2535.00 MHz) 21375 (2562.50 MHz)	15 MHz	QPSK / 16QAM	1 RB
	20850 (2510.00 MHz) 21100 (2535.00 MHz) 21350 (2560.00 MHz)	20 MHz	QPSK / 16QAM	1 RB

Test Item	Tested Channel	Channel Bandwidth	Modulation	Mode
Conducted Emission	20775 (2502.50 MHz) 21100 (2535.00 MHz) 21425 (2567.50 MHz)	5 MHz	QPSK	1 RB Full RB
	20800 (2505.00 MHz) 21100 (2535.00 MHz) 21400 (2565.00 MHz)	10 MHz	QPSK	1 RB Full RB
	20825 (2507.50 MHz) 21100 (2535.00 MHz) 21375 (2562.50 MHz)	15 MHz	QPSK	1 RB Full RB
	20850 (2510.00 MHz) 21100 (2535.00 MHz) 21350 (2560.00 MHz)	20 MHz	QPSK	1 RB Full RB
RE Below 1GHz	21100 (2535.00 MHz)	20 MHz	QPSK	1 RB
RE Above 1GHz	20775 (2502.50 MHz) 21100 (2535.00 MHz) 21425 (2567.50 MHz)	5 MHz	QPSK	1 RB
	20850 (2510.00 MHz) 21100 (2535.00 MHz) 21350 (2560.00 MHz)	20 MHz	QPSK	1 RB

For LTE Band 26 (Part 22)

Test Item	Tested Channel	Channel Bandwidth	Modulation	Mode
EIRP	26797 (824.70 MHz) 26915 (836.50 MHz) 27033 (848.30 MHz)	1.4 MHz	QPSK / 16QAM	1 RB Half RB Full RB
	26805 (825.50 MHz) 26915 (836.50 MHz) 27025 (847.50 MHz)	3 MHz	QPSK / 16QAM	1 RB Half RB Full RB
	26815 (826.50 MHz) 26915 (836.50 MHz) 27015 (846.50 MHz)	5 MHz	QPSK / 16QAM	1 RB Half RB Full RB
	26840 (829.00 MHz) 26915 (836.50 MHz) 26990 (844.00 MHz)	10 MHz	QPSK / 16QAM	1 RB Half RB Full RB
	26865 (831.50 MHz) 26915 (836.50 MHz) 26965 (841.50 MHz)	15 MHz	QPSK / 16QAM	1 RB Half RB Full RB
Modulation Characteristics	26915 (836.50 MHz)	15 MHz	QPSK / 16QAM	Full RB
Frequency Stability	26797 (824.70 MHz) 27033 (848.30 MHz)	1.4 MHz	QPSK	Full RB
	26805 (825.50 MHz) 27025 (847.50 MHz)	3 MHz	QPSK	Full RB
	26815 (826.50 MHz) 27015 (846.50 MHz)	5 MHz	QPSK	Full RB
	26840 (829.00 MHz) 26990 (844.00 MHz)	10 MHz	QPSK	Full RB
	26865 (831.50 MHz) 26965 (841.50 MHz)	15 MHz	QPSK	Full RB
Occupied Bandwidth	26797 (824.70 MHz) 26915 (836.50 MHz) 27033 (848.30 MHz)	1.4 MHz	QPSK / 16QAM	Full RB
	26805 (825.50 MHz) 26915 (836.50 MHz) 27025 (847.50 MHz)	3 MHz	QPSK / 16QAM	Full RB
	26815 (826.50 MHz) 26915 (836.50 MHz) 27015 (846.50 MHz)	5 MHz	QPSK / 16QAM	Full RB
	26840 (829.00 MHz) 26915 (836.50 MHz) 26990 (844.00 MHz)	10 MHz	QPSK / 16QAM	Full RB
	26865 (831.50 MHz) 26915 (836.50 MHz) 26965 (841.50 MHz)	15 MHz	QPSK / 16QAM	Full RB

Test Item	Tested Channel	Channel Bandwidth	Modulation	Mode
Peak to Average Ratio	26797 (824.70 MHz) 26915 (836.50 MHz) 27033 (848.30 MHz)	1.4 MHz	QPSK / 16QAM	1 RB
	26805 (825.50 MHz) 26915 (836.50 MHz) 27025 (847.50 MHz)	3 MHz	QPSK / 16QAM	1 RB
	26815 (826.50 MHz) 26915 (836.50 MHz) 27015 (846.50 MHz)	5 MHz	QPSK / 16QAM	1 RB
	26840 (829.00 MHz) 26915 (836.50 MHz) 26990 (844.00 MHz)	10 MHz	QPSK / 16QAM	1 RB
	26865 (831.50 MHz) 26915 (836.50 MHz) 26965 (841.50 MHz)	15 MHz	QPSK / 16QAM	1 RB
	26140 (1860.00 MHz) 26365 (1882.50 MHz) 26590 (1905.00 MHz)	20 MHz	QPSK / 16QAM	1 RB
	Conducted Emission	26797 (824.70 MHz) 26915 (836.50 MHz) 27033 (848.30 MHz)	1.4 MHz	QPSK
26805 (825.50 MHz) 26915 (836.50 MHz) 27025 (847.50 MHz)		3 MHz	QPSK	1 RB Full RB
26815 (826.50 MHz) 26915 (836.50 MHz) 27015 (846.50 MHz)		5 MHz	QPSK	1 RB Full RB
26840 (829.00 MHz) 26915 (836.50 MHz) 26990 (844.00 MHz)		10 MHz	QPSK	1 RB Full RB
26865 (831.50 MHz) 26915 (836.50 MHz) 26965 (841.50 MHz)		15 MHz	QPSK	1 RB Full RB
Radiated Spurious Emissions below 1GHz	26915 (836.50 MHz)	15 MHz	QPSK	1 RB
Radiated Spurious Emissions above 1GHz	26797 (824.70 MHz) 26915 (836.50 MHz) 27033 (848.30 MHz)	1.4 MHz	QPSK	1 RB
	26815 (826.50 MHz) 26915 (836.50 MHz) 27015 (846.50 MHz)	5 MHz	QPSK	1 RB
	26865 (831.50 MHz) 26915 (836.50 MHz) 26965 (841.50 MHz)	15 MHz	QPSK	1 RB

For LTE Band 26 (Part 90)

Test Item	Tested Channel	Channel Bandwidth	Modulation	Mode
EIRP	26697 (814.70 MHz) 26740 (819.00 MHz) 26783 (823.30 MHz)	1.4 MHz	QPSK / 16QAM	1 RB Half RB Full RB
	26705 (815.50 MHz) 26740 (819.00 MHz) 26775 (822.50 MHz)	3 MHz	QPSK / 16QAM	1 RB Half RB Full RB
	26715 (816.50 MHz) 26740 (819.00 MHz) 26765 (821.50 MHz)	5 MHz	QPSK / 16QAM	1 RB Half RB Full RB
	26740 (819.00 MHz)	10 MHz	QPSK / 16QAM	1 RB Half RB Full RB
Modulation Characteristics	26740 (819.00 MHz)	10MHz	QPSK / 16QAM	Full RB
Frequency Stability	26697 (814.70 MHz) 26783 (823.30 MHz)	1.4 MHz	QPSK	Full RB
	26705 (815.50 MHz) 26775 (822.50 MHz)	3 MHz	QPSK	Full RB
	26715 (816.50 MHz) 26765 (821.50 MHz)	5 MHz	QPSK	Full RB
	26740 (819.00 MHz)	10 MHz	QPSK	Full RB
Occupied Bandwidth	26697 (814.70 MHz) 26740 (819.00 MHz) 26783 (823.30 MHz)	1.4 MHz	QPSK / 16QAM	Full RB
	26705 (815.50 MHz) 26740 (819.00 MHz) 26775 (822.50 MHz)	3 MHz	QPSK / 16QAM	Full RB
	26715 (816.50 MHz) 26740 (819.00 MHz) 26765 (821.50 MHz)	5 MHz	QPSK / 16QAM	Full RB
	26740 (819.00 MHz)	10 MHz	QPSK / 16QAM	Full RB
Conducted Emission	26697 (814.70 MHz) 26740 (819.00 MHz) 26783 (823.30 MHz)	1.4 MHz	QPSK	1 RB Full RB
	26705 (815.50 MHz) 26740 (819.00 MHz) 26775 (822.50 MHz)	3 MHz	QPSK	1 RB Full RB
	26715 (816.50 MHz) 26740 (819.00 MHz) 26765 (821.50 MHz)	5 MHz	QPSK	1 RB Full RB
	26740 (819.00 MHz)	10 MHz	QPSK	1 RB Full RB
Radiated Spurious Emissions below 1GHz	26740 (819.00 MHz)	10 MHz	QPSK	1 RB
Radiated Spurious Emissions above 1GHz	26697 (814.70 MHz) 26740 (819.00 MHz) 26783 (823.30 MHz)	1.4 MHz	QPSK	1 RB
	26715 (816.50 MHz) 26740 (819.00 MHz) 26765 (821.50 MHz)	5 MHz	QPSK	1 RB
	26740 (819.00 MHz)	10 MHz	QPSK	1 RB

For LTE Band 38

Test Item	Tested Channel	Channel Bandwidth	Modulation	Mode
EIRP	37775 (2572.50MHz) 38000 (2595.00MHz) 38225 (2617.50MHz)	5MHz	QPSK / 16QAM	1 RB Half RB Full RB
	37800 (2575.00MHz) 38000 (2595.00MHz) 38200 (2615.00MHz)	10MHz	QPSK / 16QAM	1 RB Half RB Full RB
	37825 (2577.50MHz) 38000 (2595.00MHz) 38175 (2612.50MHz)	15MHz	QPSK / 16QAM	1 RB Half RB Full RB
	37850 (2580.00MHz) 38000 (2595.00MHz) 38150 (2610.00MHz)	20MHz	QPSK / 16QAM	1 RB Half RB Full RB
Modulation Characteristics	38000 (2595.00MHz)	20MHz	QPSK / 16QAM	Full RB
Frequency Stability	37775 (2572.50MHz) 38225 (2617.50MHz)	5MHz	QPSK	Full RB
	37800 (2575.00MHz) 38200 (2615.00MHz)	10MHz	QPSK	Full RB
	37825 (2577.50MHz) 38175 (2612.50MHz)	15MHz	QPSK	Full RB
	37850 (2580.00MHz) 38150 (2610.00MHz)	20MHz	QPSK	Full RB
Occupied Bandwidth	37775 (2572.50MHz) 38000 (2595.00MHz) 38225 (2617.50MHz)	5MHz	QPSK / 16QAM	Full RB
	37800 (2575.00MHz) 38000 (2595.00MHz) 38200 (2615.00MHz)	10MHz	QPSK / 16QAM	Full RB
	37825 (2577.50MHz) 38000 (2595.00MHz) 38175 (2612.50MHz)	15MHz	QPSK / 16QAM	Full RB
	37850 (2580.00MHz) 38000 (2595.00MHz) 38150 (2610.00MHz)	20MHz	QPSK / 16QAM	Full RB
Peak to Average Ratio	37775 (2572.50MHz) 38000 (2595.00MHz) 38225 (2617.50MHz)	5MHz	QPSK / 16QAM	1 RB
	37800 (2575.00MHz) 38000 (2595.00MHz) 38200 (2615.00MHz)	10MHz	QPSK / 16QAM	1 RB
	37825 (2577.50MHz) 38000 (2595.00MHz) 38175 (2612.50MHz)	15MHz	QPSK / 16QAM	1 RB
	37850 (2580.00MHz) 38000 (2595.00MHz) 38150 (2610.00MHz)	20MHz	QPSK / 16QAM	1 RB

Test Item	Tested Channel	Channel Bandwidth	Modulation	Mode
Conducted Emission	37775 (2572.50MHz) 38000 (2595.00MHz) 38225 (2617.50MHz)	5MHz	QPSK	1 RB Full RB
	37800 (2575.00MHz) 38000 (2595.00MHz) 38200 (2615.00MHz)	10MHz	QPSK	1 RB Full RB
	37825 (2577.50MHz) 38000 (2595.00MHz) 38175 (2612.50MHz)	15MHz	QPSK	1 RB Full RB
	37850 (2580.00MHz) 38000 (2595.00MHz) 38150 (2610.00MHz)	20MHz	QPSK	1 RB Full RB
Radiated Spurious Emissions below 1GHz	38000 (2595.00MHz)	20MHz	QPSK	1 RB
Radiated Spurious Emissions above 1GHz	37775 (2572.50MHz) 38000 (2595.00MHz) 38225 (2617.50MHz)	5MHz	QPSK	1 RB
	37850 (2580.00MHz) 38000 (2595.00MHz) 38150 (2610.00MHz)	20MHz	QPSK	1 RB

For LTE Band 41

Test Item	Tested Channel	Channel Bandwidth	Modulation	Mode
EIRP	40265 (2557.50 MHz) 40690 (2600.00 MHz) 41215 (2652.50 MHz)	5 MHz	QPSK / 16QAM	1 RB Half RB Full RB
	40290 (2560.00 MHz) 40690 (2600.00 MHz) 41190 (2650.00 MHz)	10 MHz	QPSK / 16QAM	1 RB Half RB Full RB
	40315 (2562.50 MHz) 40690 (2600.00 MHz) 41165 (2647.50 MHz)	15 MHz	QPSK / 16QAM	1 RB Half RB Full RB
	40340 (2565.00 MHz) 40690 (2600.00 MHz) 41140 (2645.00 MHz)	20 MHz	QPSK / 16QAM	1 RB Half RB Full RB
Modulation Characteristics	40690 (2600.00 MHz)	20 MHz	QPSK / 16QAM	Full RB
Frequency Stability	40265 (2557.50 MHz) 41215 (2652.50 MHz)	5 MHz	QPSK	Full RB
	40290 (2560.00 MHz) 41190 (2650.00 MHz)	10 MHz	QPSK	Full RB
	40315 (2562.50 MHz) 41165 (2647.50 MHz)	15 MHz	QPSK	Full RB
	40340 (2565.00 MHz) 41140 (2645.00 MHz)	20 MHz	QPSK	Full RB
Occupied Bandwidth	40265 (2557.50 MHz) 40690 (2600.00 MHz) 41215 (2652.50 MHz)	5 MHz	QPSK / 16QAM	Full RB
	40290 (2560.00 MHz) 40690 (2600.00 MHz) 41190 (2650.00 MHz)	10 MHz	QPSK / 16QAM	Full RB
	40315 (2562.50 MHz) 40690 (2600.00 MHz) 41165 (2647.50 MHz)	15 MHz	QPSK / 16QAM	Full RB
	40340 (2565.00 MHz) 40690 (2600.00 MHz) 41140 (2645.00 MHz)	20 MHz	QPSK / 16QAM	Full RB
Peak to Average Ratio	40265 (2557.50 MHz) 40690 (2600.00 MHz) 41215 (2652.50 MHz)	5 MHz	QPSK / 16QAM	1 RB
	40290 (2560.00 MHz) 40690 (2600.00 MHz) 41190 (2650.00 MHz)	10 MHz	QPSK / 16QAM	1 RB
	40315 (2562.50 MHz) 40690 (2600.00 MHz) 41165 (2647.50 MHz)	15 MHz	QPSK / 16QAM	1 RB
	40340 (2565.00 MHz) 40690 (2600.00 MHz) 41140 (2645.00 MHz)	20 MHz	QPSK / 16QAM	1 RB

Test Item	Tested Channel	Channel Bandwidth	Modulation	Mode
Conducted Emission	40265 (2557.50 MHz) 40690 (2600.00 MHz) 41215 (2652.50 MHz)	5 MHz	QPSK	1 RB Full RB
	40290 (2560.00 MHz) 40690 (2600.00 MHz) 41190 (2650.00 MHz)	10 MHz	QPSK	1 RB Full RB
	40315 (2562.50 MHz) 40690 (2600.00 MHz) 41165 (2647.50 MHz)	15 MHz	QPSK	1 RB Full RB
	40340 (2565.00 MHz) 40690 (2600.00 MHz) 41140 (2645.00 MHz)	20 MHz	QPSK	1 RB Full RB
RE Below 1GHz	40690 (2600.00 MHz)	20 MHz	QPSK	1 RB
RE Above 1GHz	40265 (2557.50 MHz) 40690 (2600.00 MHz) 41215 (2652.50 MHz)	5 MHz	QPSK	1 RB
	40340 (2565.00 MHz) 40690 (2600.00 MHz) 41140 (2645.00 MHz)	20 MHz	QPSK	1 RB

3.4 Test Program Used and Operation Descriptions

There is no need to controlling software during the test, and the EUT can be paired with the Radio Communication Analyzer to test the connection when it is powered on.

3.5 Connection Diagram of EUT and Peripheral Devices

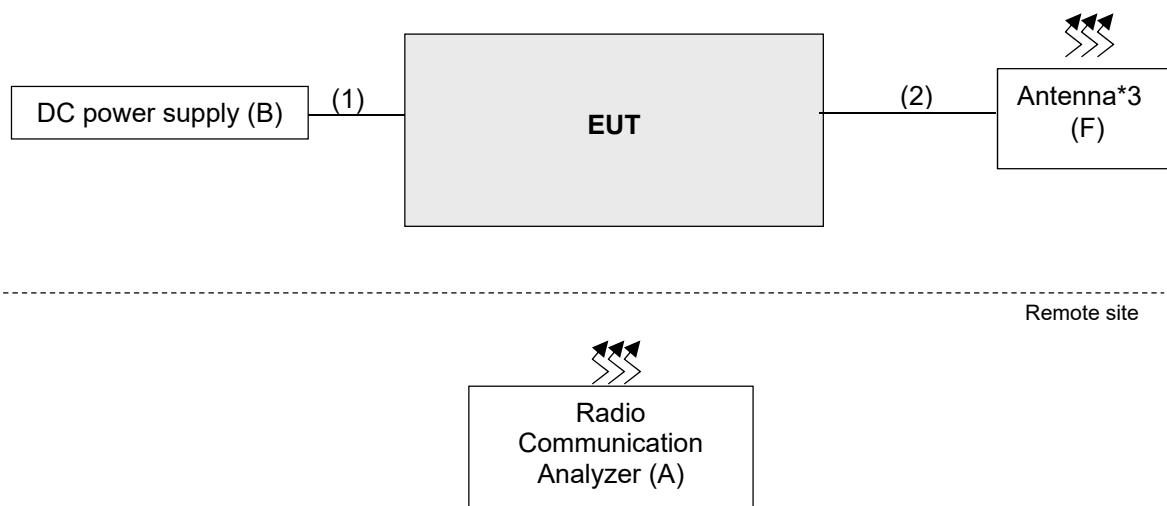

3.6 Configuration of Peripheral Devices and Cable Connections

ID	Product	Brand	Model No.	Serial No.	FCC ID	Remarks
A	Radio Communication Analyzer	Anritsu	MT8821C	6201462755	N/A	Provided by Lab
B	DC power supply	JIN YIH Technology	SP3051	N/A	N/A	Provided by Lab
C	Antenna*3	N/A	N/A	N/A	N/A	Supplied by applicant

ID	Cable Descriptions	Qty.	Length (m)	Shielding (Yes/No)	Cores (Qty.)	Remarks
1	DC Cable	1	1	No	0	Supplied by applicant
2	Antenna Cable	3	1.6	Yes	0	Supplied by applicant

4 Test Instruments

The calibration interval of the all test instruments are 12 months and the calibrations are traceable to NML/ROC and NIST/USA.

4.1 Effective Radiated Power and Equivalent Isotropically Radiated Power

Description Manufacturer	Model No.	Serial No.	Calibrated Date	Calibrated Until
N9030B - PXA Signal Analyzer KEYSIGHT	N9030B	MY57140488	2023/3/6	2024/3/5
Radio Communication Analyzer Anritsu	MT8821C	6201462755	2023/3/3	2024/3/2
Software BV	ADT_RF Test Software V6.6.5.4	N/A	N/A	N/A

Notes:

1. The test was performed in Oven room.
2. Tested Date: 2023/7/17~ 2023/7/20

4.2 Modulation Characteristics

Refer to section 4.1 to get information of the instruments.

4.3 Peak to Average Ratio

Refer to section 4.1 to get information of the instruments.

4.4 Bandwidth

Refer to section 4.1 to get information of the instruments.

4.5 Conducted Spurious Emissions

Refer to section 4.1 to get information of the instruments.

4.6 Radiated Spurious Emissions below 1GHz

Description Manufacturer	Model No.	Serial No.	Calibrated Date	Calibrated Until
Antenna Tower inn-co GmbH	MA 4000	010303	N/A	N/A
Bi_Log Antenna Schwarzbeck	VULB 9168	9168-155	2022/10/21	2023/10/20
EMI Test Receiver R&S	ESR3	102782	2022/12/12	2023/12/11
Loop Antenna Electro-Metrics	EM-6879	269	2022/9/19	2023/9/18
Loop Antenna TESEQ	HLA 6121	45745	2022/7/27	2023/7/26
Preamplifier Agilent	8447D	2944A10631	2023/5/7	2024/5/6
Preamplifier EMCI	EMC001340	980201	2022/9/23	2023/9/22
RF Coaxial Cable EMCI	5D-NM-BM	140903+140902	2023/1/7	2024/1/6
RF Coaxial Cable Woken	8D-FB	Cable-CH4-01	2022/7/9	2023/7/8
Signal & Spectrum Analyzer R&S	FSW43	101866	2023/1/10	2024/1/9
Software BV ADT	ADT_Radiated_ V7.6.15.9.5	N/A	N/A	N/A
Turn Table BV ADT	TT100	TT93021705	N/A	N/A
Turn Table Controller BV ADT	SC100	SC93021705	N/A	N/A

Notes:

1. The test was performed in HY - 966 chamber 3.
2. Tested Date: 2023/7/5

4.7 Radiated Spurious Emissions above 1GHz

Description Manufacturer	Model No.	Serial No.	Calibrated Date	Calibrated Until
Antenna Tower inn-co GmbH	MA 4000	010303	N/A	N/A
Boresight antenna tower fixture BV	BAF-02	5	N/A	N/A
EMI Test Receiver R&S	ESR3	102782	2022/12/12	2023/12/11
Horn Antenna Schwarzbeck	BBHA 9120D	9120D-408	2022/11/13	2023/11/12
	BBHA 9170	9170-480	2022/11/13	2023/11/12
		BBHA9170241	2022/10/20	2023/10/19
		BBHA9170243	2022/11/13	2023/11/12
Preamplifier EMCI	EMC 184045	980116	2022/10/1	2023/9/30
Preamplifier Keysight	83017A	MY53270295	2023/5/7	2024/5/6
RF Coaxial Cable EMCI	EMC102-KM-KM-600	150928	2022/7/9	2023/7/8
	EMC102-KM-KM-3000	150929	2022/7/9	2023/7/8
RF Coaxial Cable HUBER+SUHNER	SUCOFLEX 104	Cable-CH4-03(250724)	2023/5/7	2024/5/6
	Sucoflex 104	MY 13380+295012/04	2023/5/7	2024/5/6
Signal & Spectrum Analyzer R&S	FSW43	101866	2023/1/10	2024/1/9
Software BV ADT	ADT_Radiated_ V7.6.15.9.5	N/A	N/A	N/A
Turn Table BV ADT	TT100	TT93021705	N/A	N/A
Turn Table Controller BV ADT	SC100	SC93021705	N/A	N/A

Notes:

1. The test was performed in HY - 966 chamber 3.
2. Tested Date: 2023/7/5

4.8 Frequency Stability

Description Manufacturer	Model No.	Serial No.	Calibrated Date	Calibrated Until
3-channel DC power supply JIN YIH Technology	ODP3033	ODP30332128138	N/A	N/A
Digital Multimeter Fluke	87-III	70360742	2023/7/6	2024/7/5
Signal and spectrum analyzer R&S	FSV3044	101105	2023/2/22	2024/2/21
Software BV	ADT_RF Test Software V6.6.5.4	N/A	N/A	N/A
Temperature & Humidity Chamber TERCHY	HRM-120RF	931022	2022/12/27	2023/12/26
Radio Communication Analyzer Anritsu	MT8821C	6201462755	2023/3/3	2024/3/2

Notes:

1. The test was performed in Oven room.
2. Tested Date: 2023/7/18

5 Limits of Test Items

5.1 Effective Radiated Power and Equivalent Isotropically Radiated Power

For WCDMA Band 5, LTE Band 5, LTE Band 26 (Part 22):

The ERP of mobile transmitters and auxiliary test transmitters must not exceed 7 watts.

For LTE Band 7, LTE Band 38, LTE Band 41:

Mobile stations are limited to 2.0 watts EIRP. All user stations are limited to 2.0 watts transmitter output power.

For LTE Band 26 (Part 90):

The maximum output power of the transmitter for mobile stations is 100 watts (20 dBw) ERP.

5.2 Modulation Characteristics

A curve or equivalent data which shows that the equipment will meet the modulation requirements of the rules under which the equipment is to be licensed.

5.3 Peak to Average Ratio

In measuring transmissions in this band using an average power technique, the peak to-average ratio (PAR) of the transmission may not exceed 13 dB.

5.4 Bandwidth

According to FCC 47 CFR part 2.1049, the occupied bandwidth, that is the frequency bandwidth such that, below its lower and above its upper frequency limits, the mean powers radiated are each equal to 0.5% of the total mean power radiated by a given emission.

5.5 Conducted Spurious Emissions

For WCDMA Band 5, LTE Band 5, LTE Band 26 (Part 22):

The power of any emission outside of the authorized operating frequency ranges must be attenuated below the transmitting power (P) by a factor of at least $43 + 10 \log(P)$ dB. The emission limit equal to -13 dBm.

For LTE Band 7, LTE Band 38, LTE Band 41:

According to FCC 47 CFR part 27.53(m)(4) regulations, any transmit power outside of the channel edge must be attenuated below the transmitting power (P) by a factor shall be not less than $40 + 10 \log(P)$ dB on all frequencies between the channel edge and 5 megahertz from the channel edge, $43 + 10 \log(P)$ dB on all frequencies between 5 megahertz and X megahertz from the channel edge, and $55 + 10 \log(P)$ dB on all frequencies more than X megahertz from the channel edge, where X is the greater of 6 megahertz or the actual emission bandwidth. In addition, the attenuation factor shall not be less than $43 + 10 \log(P)$ dB on all frequencies between 2490.5 MHz and 2496 MHz and $55 + 10 \log(P)$ dB at or below 2490.5 MHz. In the 1 MHz bands immediately outside and adjacent to the frequency block a resolution bandwidth of at least two percent may be employed, except when the 1 megahertz band is 2495-2496 MHz, in which case a resolution bandwidth of at least one percent may be employed.

For LTE Band 26 (Part 90):

For any frequency removed from the EA licensee's frequency block greater than 37.5 kHz, the power of any emission shall be attenuated below the transmitter power (P) in watts by at least $43 + 10 \log_{10}(P)$ decibels or 80 decibels, whichever is the lesser attenuation, where f is the frequency removed from the center of the outer channel in the block in kilohertz and where f is greater than 37.5 kHz.

For §90.691(a), RBW = 100 kHz for offset greater than 37.5 kHz from channel edge is allowed.

5.6 Radiated Spurious Emissions below 1GHz

For WCDMA Band 5, LTE Band 5, LTE Band 26 (Part 22):

The power of any emission outside of the authorized operating frequency ranges must be attenuated below the transmitting power (P) by a factor of at least $43 + 10 \log(P)$ dB. The emission limit equal to -13 dBm.

For LTE Band 7, LTE Band 38, LTE Band 41:

According to FCC 47 CFR part 27.53(m)(4), on any frequency outside a licensee's frequency block, The power of any emission shall be attenuated below the transmitter power (P) by at least $55 + 10 \log(P)$ dB. The emission limit equal to -25 dBm.

For LTE Band 26 (Part 90):

For any frequency removed from the EA licensee's frequency block greater than 37.5 kHz, the power of any emission shall be attenuated below the transmitter power (P) in watts by at least $43 + 10 \log_{10}(P)$ decibels or 80 decibels, whichever is the lesser attenuation, where f is the frequency removed from the center of the outer channel in the block in kilohertz and where f is greater than 37.5 kHz.

For §90.691(a), RBW = 100 kHz for offset greater than 37.5 kHz from channel edge is allowed.

5.7 Radiated Spurious Emissions above 1GHz

For WCDMA Band 5, LTE Band 5, LTE Band 26 (Part 22):

The power of any emission outside of the authorized operating frequency ranges must be attenuated below the transmitting power (P) by a factor of at least $43 + 10 \log(P)$ dB. The emission limit equal to -13 dBm.

For LTE Band 7, LTE Band 38, LTE Band 41:

According to FCC 47 CFR part 27.53(m)(4), on any frequency outside a licensee's frequency block, The power of any emission shall be attenuated below the transmitter power (P) by at least $55 + 10 \log(P)$ dB. The emission limit equal to -25 dBm.

For LTE Band 26 (Part 90):

For any frequency removed from the EA licensee's frequency block greater than 37.5 kHz, the power of any emission shall be attenuated below the transmitter power (P) in watts by at least $43 + 10 \log_{10}(P)$ decibels or 80 decibels, whichever is the lesser attenuation, where f is the frequency removed from the center of the outer channel in the block in kilohertz and where f is greater than 37.5 kHz.

For §90.691(a), RBW = 100 kHz for offset greater than 37.5 kHz from channel edge is allowed.

5.8 Frequency Stability

For WCDMA Band 5, LTE Band 5, LTE Band 26 (Part 22 and Part 90):

1.5 ppm is for base and fixed station. 2.5 ppm is for mobile station.

For LTE Band 7, LTE Band 38, LTE Band 41

The frequency stability shall be sufficient to ensure that the fundamental emissions stay within the authorized bands of operation (authorized frequency block).

6 Test Arrangements

6.1 Effective Radiated Power and Equivalent Isotropically Radiated Power

6.1.1 Test Setup

Conducted Power Measurement:

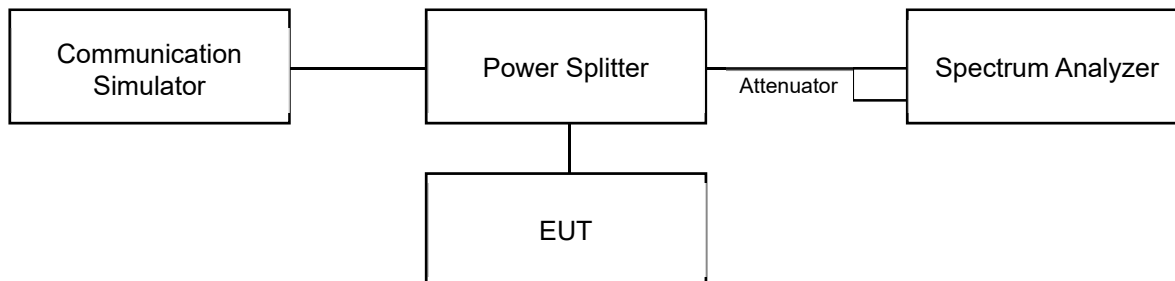

6.1.2 Test Procedure

Conducted Power Measurement:

The EUT is configured by emulator to set data modulation and maximum power using WWAN technology. The average (ms) power measurement was performed on emulator and power value was measured from power function on emulator. Set the EUT to transmit under low, middle and high channel and record the power level shown on simulator.

Maximum EIRP / ERP

The relevant equation for determining the maximum ERP or EIRP from the measured RF output power is given in Equation as follows:

$$\text{EIRP} = P_{\text{Meas}} + G_{\text{T}}$$

$$\text{ERP} = P_{\text{Meas}} + G_{\text{T}} - 2.15$$

where

ERP or EIRP effective radiated power or equivalent isotropically radiated power, respectively

(expressed in the same units as P_{Meas} , e.g., dBm or dBW)

P_{Meas} measured transmitter output power or PSD, in dBm or dBW

G_{T} gain of the transmitting antenna, in dBd (ERP) or dBi (EIRP)

6.2 Modulation Characteristics

6.2.1 Test Setup

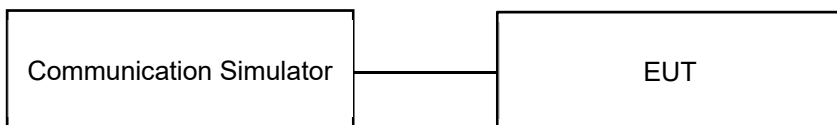

6.2.2 Test Procedure

Connect the EUT to Communication Simulator via the antenna connector, the frequency band is set as EUT supported Modulation and Channels, the EUT output is matched with 50 ohm load, the waveform quality and constellation of the EUT was tested.

6.3 Peak to Average Ratio

6.3.1 Test Setup

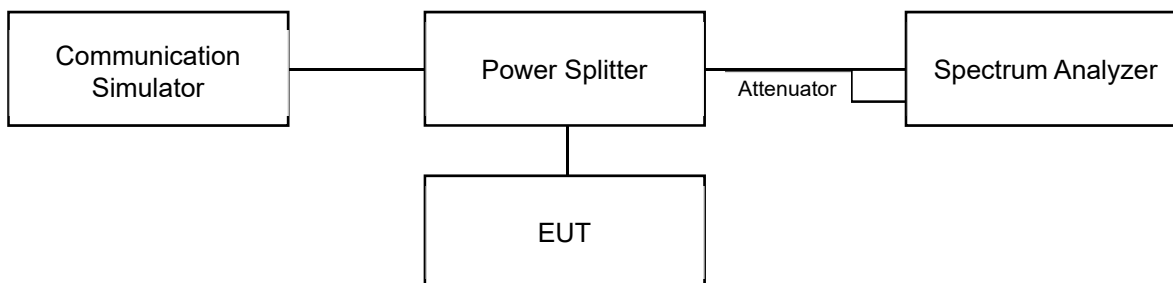

6.3.2 Test Procedure

- a. Set resolution/measurement bandwidth \geq signal's occupied bandwidth;
- b. Set the number of counts to a value that stabilizes the measured CCDF curve;
- c. Record the maximum PAPR level associated with a probability of 0.1%.

6.4 Bandwidth

6.4.1 Test Setup

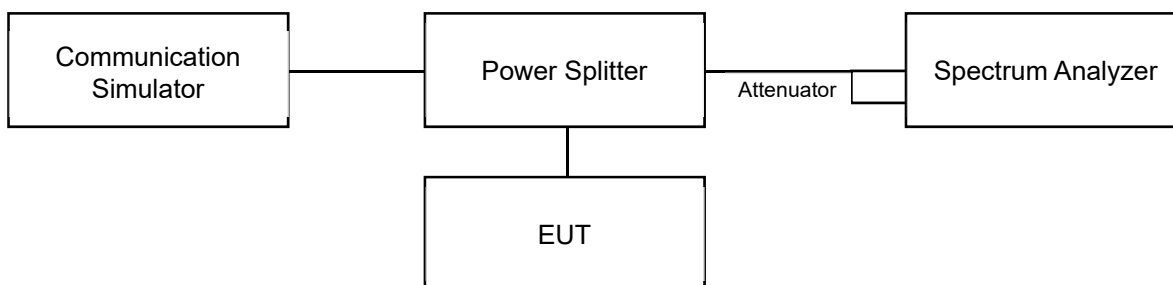

6.4.2 Test Procedure

For the 26 dBc bandwidth measurement method, please refer to section 5.4.3 of ANSI C63.26.

- a. The spectrum analyzer center frequency is set to the nominal EUT channel center frequency. The span range for the spectrum analyzer shall be wide enough to see sufficient roll off of the signal to make the measurement.
- b. The nominal RBW shall be in the range of 1% to 5% of the anticipated OBW, and the VBW shall be set $\geq 3 \times$ RBW.
- c. Set the reference level of the instrument as required to prevent the signal amplitude from exceeding the maximum spectrum analyzer input mixer level for linear operation. See guidance provided in 4.2.3.
- d. The dynamic range of the spectrum analyzer at the selected RBW shall be more than 10 dB below the target “-X dB” requirement, i.e., if the requirement calls for measuring the -26 dB OBW, the spectrum analyzer noise floor at the selected RBW shall be at least 36 dB below the reference level.
- e. Set spectrum analyzer detection mode to peak, and the trace mode to max hold.
- f. Determine the following reference values: Set the EUT to transmit a modulated signal. Allow the trace to stabilize. Set the spectrum analyzer marker to the highest level of the displayed trace (this is the reference value).
- g. Determine the “-X dB amplitude” as equal to (Reference Value - X). Alternatively, this calculation can be performed on the spectrum analyzer using the delta-marker measurement function.
- h. Place two markers, one at the lowest and the other at the highest frequency of the envelope of the spectral display such that each marker is at or slightly below the “-X dB amplitude” determined in step f). If a marker is below this “-X dB amplitude” value it should be as close as possible to this value. The OBW is the positive frequency difference between the two markers.
- i. The OBW shall be reported by providing plot(s) of the measuring instrument display, to include markers depicting the relevant frequency and amplitude information (e.g., marker table). The frequency and amplitude axis and scale shall be clearly labeled. Tabular data may be reported in addition to the plot(s).

For the occupied bandwidth measurement method, please refer to section 5.4.4 of ANSI C63.26.

- a. The spectrum analyzer center frequency is set to the nominal EUT channel center frequency. The span range for the spectrum analyzer shall be wide enough to see sufficient roll off of the signal to make the measurement.
- b. The nominal RBW shall be in the range of 1% to 5% of the anticipated OBW, and the VBW shall be set $\geq 3 \times$ RBW.
- c. Set the reference level of the instrument as required to prevent the signal amplitude from exceeding the maximum spectrum analyzer input mixer level for linear operation. See guidance provided in 4.2.3.
- d. The dynamic range of the spectrum analyzer at the selected RBW shall be more than 10 dB below the target “-X dB” requirement, i.e., if the requirement calls for measuring the -26 dB OBW, the spectrum analyzer noise floor at the selected RBW shall be at least 36 dB below the reference level.
- e. Set spectrum analyzer detection mode to peak, and the trace mode to max hold.
- f. Determine the reference value by either of the following:
 - g. 1) Set the EUT to transmit a modulated signal. Allow the trace to stabilize. Set the spectrum analyzer marker to the highest level of the displayed trace (this is the reference value).
 - h. 2) Set the EUT to transmit an unmodulated carrier. Set the spectrum analyzer marker to the level of the carrier.
- i. Determine the “-X dB amplitude” as equal to (Reference Value - X). Alternatively, this calculation can be performed on the spectrum analyzer using the delta-marker measurement function.
- j. If the reference value was determined using an unmodulated carrier, turn the EUT modulation on, then either clear the existing trace or start a new trace on the spectrum analyzer and allow the new trace to stabilize. Otherwise the trace from step f) shall be used for step i).
- k. Place two markers, one at the lowest and the other at the highest frequency of the envelope of the spectral display such that each marker is at or slightly below the “-X dB amplitude” determined in step f). If a marker is below this “-X dB amplitude” value it should be as close as possible to this value. The OBW is the positive frequency difference between the two markers. The spectral envelope can cross the “-X dB amplitude” at multiple points. The lowest or highest frequency shall be selected as the frequencies that are the farthest away from the center frequency at which the spectral envelope crosses the “-X dB amplitude.”
- l. The OBW shall be reported by providing plot(s) of the measuring instrument display, to include markers depicting the relevant frequency and amplitude information (e.g., marker table). The frequency and amplitude axis and scale shall be clearly labeled. Tabular data may be reported in addition to the plot(s).

6.5 Conducted Spurious Emissions

6.5.1 Test Setup

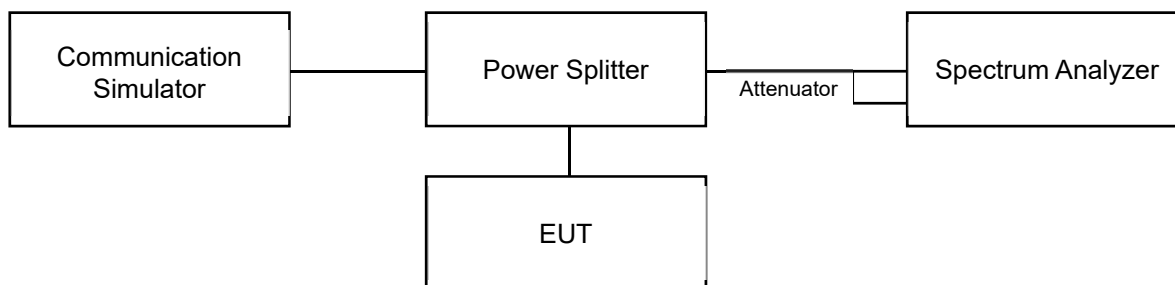

6.5.2 Test Procedure

- a. Measurement refer to ANSI C63.26 section 5.7.
- b. All measurements were done at 3 channels: low, middle and high operational frequency range.
- c. Measuring frequency range is from 9 kHz up to the tenth harmonic of the highest fundamental frequency or to 40 GHz, whichever is lower. 20 dB attenuation pad is connected with spectrum.
- d. The fundamental frequency above 1 GHz, the spectrum set RBW = 1 MHz, VBW = 3 MHz, Detector = Average.
- e. The fundamental frequency below 1 GHz, the spectrum set RBW \geq 100 kHz, VBW \geq 3 x RBW, Detector = Average.
- f. Measuring frequency band edge, narrow RBW (no less than 1% of the OBW) is used for conducted emission measurement.

6.6 Radiated Spurious Emissions below 1GHz

6.6.1 Test Setup

For radiated emission 30 MHz to 1 GHz

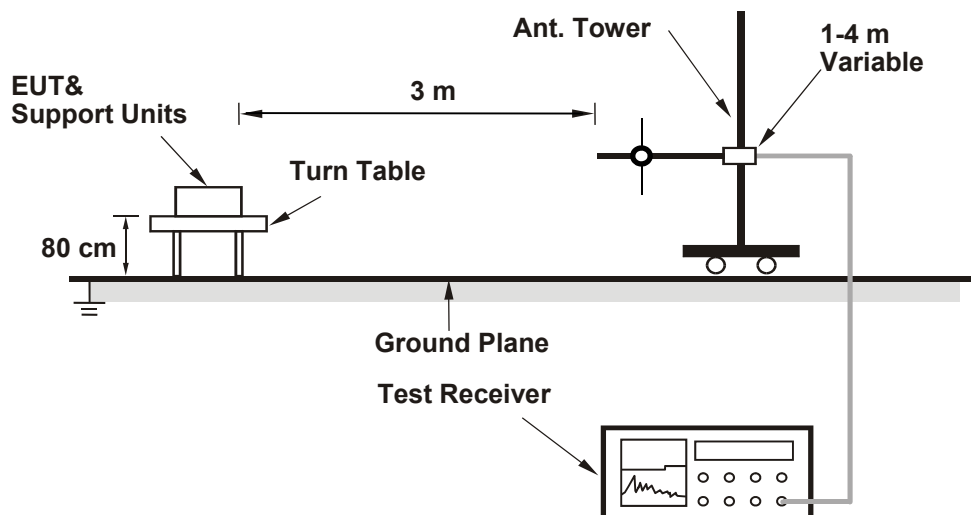

For the actual test configuration, please refer to the attached file (Test Setup Photo).

6.6.2 Test Procedure

The EUT is configured by emulator to set data modulation and maximum power using WWAN technology.

- In the semi-anechoic chamber, EUT placed on the 0.8 m (below or equal 1 GHz) height of turn table, rotated the table around 360 degrees to search the maximum radiation power and receiver antenna shall be rotated vertical and horizontal polarization and moved height from 1 m to 4 m to find the maximum polar radiated power. The "Read Value" is the spectrum reading the maximum power value.
- The height of antenna is varied from one meter to four meters above the ground to determine the maximum value of the field strength. Both horizontal and vertical polarizations of the antenna are set to make the measurement.
- Perform a field strength measurement and record the worse read value, is the field strength value via a spectrum reading obtained corrected for antenna factor, cable loss and pre-amplifier factor and then mathematically convert the measured field strength level to EIRP/ERP level.
- Following C63.26 section 5.5 and 5.2.7
- $EIRP (dBm) = E (dB\mu V/m) + 20\log(D) - 104.8$; where D is the measurement distance (in the far field region) in m.
- $ERP (dBm) = E (dB\mu V/m) + 20\log(D) - 104.8 - 2.15$; where D is the measurement distance (in the far field region) in m.

Note:

- The resolution bandwidth and video bandwidth of test receiver/spectrum analyzer is 1 MHz/3 MHz.
- The emission levels were against the limit of frequency range 9 kHz ~ 30 MHz:
The amplitude of spurious emissions attenuated more than 20 dB below the permissible value is not required to be report.

6.7 Radiated Spurious Emissions above 1GHz

6.7.1 Test Setup

For radiated emission above 1 GHz

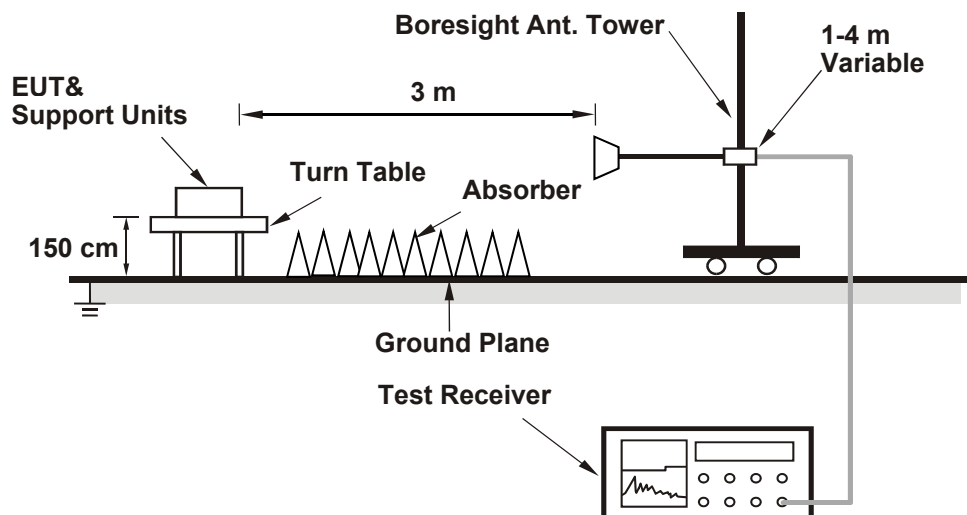

For the actual test configuration, please refer to the attached file (Test Setup Photo).

6.7.2 Test Procedure

The EUT is configured by emulator to set data modulation and maximum power using WWAN technology.

- In the semi-anechoic chamber, EUT placed on the 1.5 m height of turn table, rotated the table around 360 degrees to search the maximum radiation power and receiver antenna shall be rotated vertical and horizontal polarization and moved height from 1 m to 4 m to find the maximum polar radiated power. The "Read Value" is the spectrum reading the maximum power value.
- The height of antenna is varied from one meter to four meters above the ground to determine the maximum value of the field strength. Both horizontal and vertical polarizations of the antenna are set to make the measurement.
- Perform a field strength measurement and record the worse read value, is the field strength value via a spectrum reading obtained corrected for antenna factor, cable loss and pre-amplifier factor and then mathematically convert the measured field strength level to EIRP/ERP level.
- Following C63.26 section 5.5 and 5.2.7
- $EIRP (dBm) = E (dB\mu V/m) + 20\log(D) - 104.8$; where D is the measurement distance (in the far field region) in m.
- $ERP (dBm) = E (dB\mu V/m) + 20\log(D) - 104.8 - 2.15$; where D is the measurement distance (in the far field region) in m.

Note:

- The resolution bandwidth and video bandwidth of test receiver/spectrum analyzer is 1 MHz/3 MHz.

6.8 Frequency Stability

6.8.1 Test Setup

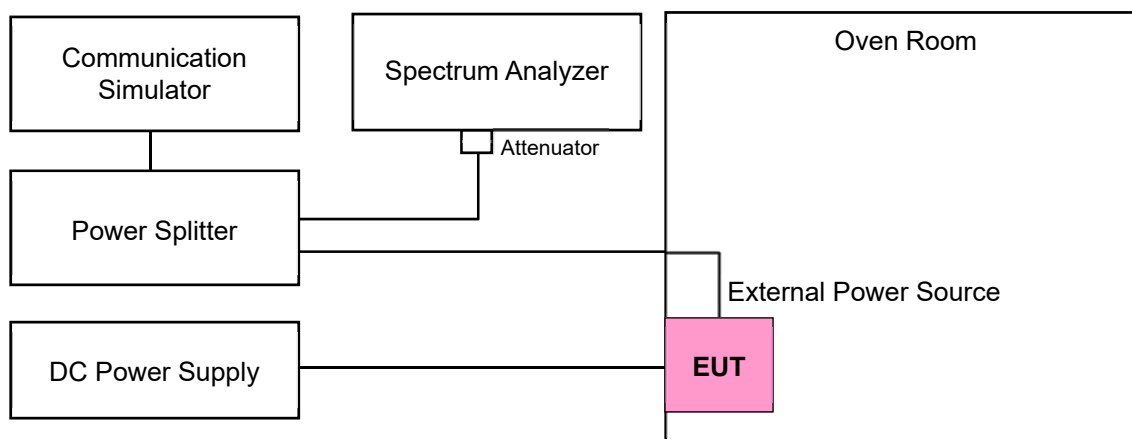

6.8.2 Test Procedure

The EUT is configured by emulator to set data modulation and maximum power using WWAN technology.

- Device is placed at the oven room. The oven room could control the temperatures and humidity. Power warm up is at least 15 min and power applied should perform before recording frequency error.
- EUT is connected the external power supply to control the DC input power. The test voltage range is from minimum to maximum working voltage. Each step shall be record the frequency error rate.
- The temperature range step is 10 degrees in this test items. All temperature levels shall be hold the $\pm 0.5^{\circ}\text{C}$ during the measurement testing. The each temperature step shall be at least 0.5 hours, consider the EUT could be test under the stability condition.

Note: The frequency error was recorded frequency error from the communication simulator.

7 Test Results of Test Item

7.1 Effective Radiated Power and Equivalent Isotropically Radiated Power

Input Power:	3.8 Vdc	Environmental Conditions:	27°C, 68% RH	Tested By:	Noah Chang
--------------	---------	---------------------------	--------------	------------	------------

7.1.1 WCDMA Band 5

Conducted Output Power (dBm)

Band	WCDMA V		
TX Channel	4132	4182	4233
Rx Channel	4357	4407	4458
Frequency	826.4	836.4	846.6
RMC 12.2K	23.39	23.50	23.46
HSDPA	23.06	23.26	23.22
HSUPA	22.59	22.77	22.76

ERP Power (dBm)

Band	WCDMA V		
TX Channel	4132	4182	4233
Rx Channel	4357	4407	4458
Frequency	826.4	836.4	846.6
RMC 12.2K	23.24	23.35	23.31
HSDPA	22.91	23.11	23.07
HSUPA	22.44	22.62	22.61

*ERP (dBm) = Conducted Output Power (dBm) + Antenna Gain (dBi) - 2.15

7.1.2 LTE Band 5
Conducted Output Power (dBm)

BW	MCS Index	RB Size	RB Offset	Low	Mid	High
		Channel		20450	20525	20600
		Frequency (MHz)		829	836.5	844
10M	QPSK	1	0	23.87	23.92	23.82
		1	24	23.71	23.75	23.65
		1	49	23.74	23.80	23.75
		25	0	23.06	23.12	23.07
		25	12	22.93	23.02	23.00
		25	25	22.97	23.11	23.10
		50	0	23.06	23.10	23.01
10M	16QAM	1	0	23.00	22.95	22.92
		1	24	22.82	22.87	22.68
		1	49	22.82	22.90	22.87
		25	0	22.10	22.23	22.15
		25	12	22.02	22.05	22.06
		25	25	22.10	22.24	22.23
		50	0	22.08	22.23	22.04
BW	MCS Index	RB Size	RB Offset	Low	Mid	High
		Channel		20425	20525	20625
		Frequency (MHz)		826.5	836.5	846.5
5M	QPSK	1	0	23.86	23.90	23.75
		1	12	23.70	23.80	23.74
		1	24	23.81	23.86	23.79
		12	0	23.03	23.06	22.96
		12	6	23.00	23.15	23.06
		12	13	22.85	22.98	22.86
		25	0	23.06	23.10	22.96
5M	16QAM	1	0	22.98	22.99	22.83
		1	12	22.75	22.80	22.82
		1	24	22.82	22.99	22.92
		12	0	22.04	22.12	22.03
		12	6	22.08	22.21	22.17
		12	13	21.93	22.10	21.97
		25	0	22.19	22.15	22.02

BW	MCS Index	RB Size	RB Offset	Low	Mid	High
		Channel		20415	20525	20635
		Frequency (MHz)		825.5	836.5	847.5
3M	QPSK	1	0	23.83	23.88	23.75
		1	7	23.71	23.75	23.73
		1	14	23.58	23.69	23.55
		8	0	22.96	23.11	23.10
		8	3	22.98	23.10	22.96
		8	7	22.85	22.98	22.87
		15	0	22.90	22.99	22.91
3M	16QAM	1	0	22.93	22.93	22.80
		1	7	22.77	22.81	22.77
		1	14	22.70	22.78	22.55
		8	0	21.99	22.13	22.17
		8	3	22.10	22.18	22.04
		8	7	21.85	22.00	21.87
		15	0	22.03	22.11	22.00
BW	MCS Index	RB Size	RB Offset	Low	Mid	High
		Channel		20407	20525	20643
		Frequency (MHz)		824.7	836.5	848.3
1.4M	QPSK	1	0	23.79	23.87	23.77
		1	2	23.71	23.85	23.70
		1	5	23.76	23.79	23.65
		3	0	23.63	23.69	23.65
		3	1	23.79	23.88	23.78
		3	3	23.73	23.81	23.67
		6	0	23.02	23.11	23.07
1.4M	16QAM	1	0	22.83	22.97	22.88
		1	2	22.71	22.96	22.79
		1	5	22.83	22.92	22.65
		3	0	22.69	22.71	22.66
		3	1	22.88	22.97	22.85
		3	3	22.77	22.86	22.78
		6	0	22.05	22.16	22.20



ERP Power (dBm)

BW	MCS Index	RB Size	RB Offset	Low	Mid	High
		Channel		20450	20525	20600
		Frequency (MHz)		829	836.5	844
10M	QPSK	1	0	23.72	23.77	23.67
		1	24	23.56	23.60	23.50
		1	49	23.59	23.65	23.60
		25	0	22.91	22.97	22.92
		25	12	22.78	22.87	22.85
		25	25	22.82	22.96	22.95
		50	0	22.91	22.95	22.86
10M	16QAM	1	0	22.85	22.80	22.77
		1	24	22.67	22.72	22.53
		1	49	22.67	22.75	22.72
		25	0	21.95	22.08	22.00
		25	12	21.87	21.90	21.91
		25	25	21.95	22.09	22.08
		50	0	21.93	22.08	21.89
BW	MCS Index	RB Size	RB Offset	Low	Mid	High
		Channel		20425	20525	20625
		Frequency (MHz)		826.5	836.5	846.5
5M	QPSK	1	0	23.71	23.75	23.60
		1	12	23.55	23.65	23.59
		1	24	23.66	23.71	23.64
		12	0	22.88	22.91	22.81
		12	6	22.85	23.00	22.91
		12	13	22.70	22.83	22.71
		25	0	22.91	22.95	22.81
5M	16QAM	1	0	22.83	22.84	22.68
		1	12	22.60	22.65	22.67
		1	24	22.67	22.84	22.77
		12	0	21.89	21.97	21.88
		12	6	21.93	22.06	22.02
		12	13	21.78	21.95	21.82
		25	0	22.04	22.00	21.87

*ERP (dBm) = Conducted Output Power (dBm) + Antenna Gain (dBi) - 2.15

BW	MCS Index	RB Size	RB Offset	Low	Mid	High
		Channel		20415	20525	20635
		Frequency (MHz)		825.5	836.5	847.5
3M	QPSK	1	0	23.68	23.73	23.60
		1	7	23.56	23.60	23.58
		1	14	23.43	23.54	23.40
		8	0	22.81	22.96	22.95
		8	3	22.83	22.95	22.81
		8	7	22.70	22.83	22.72
		15	0	22.75	22.84	22.76
3M	16QAM	1	0	22.78	22.78	22.65
		1	7	22.62	22.66	22.62
		1	14	22.55	22.63	22.40
		8	0	21.84	21.98	22.02
		8	3	21.95	22.03	21.89
		8	7	21.70	21.85	21.72
		15	0	21.88	21.96	21.85
BW	MCS Index	RB Size	RB Offset	Low	Mid	High
		Channel		20407	20525	20643
		Frequency (MHz)		824.7	836.5	848.3
1.4M	QPSK	1	0	23.64	23.72	23.62
		1	2	23.56	23.70	23.55
		1	5	23.61	23.64	23.50
		3	0	23.48	23.54	23.50
		3	1	23.64	23.73	23.63
		3	3	23.58	23.66	23.52
		6	0	22.87	22.96	22.92
1.4M	16QAM	1	0	22.68	22.82	22.73
		1	2	22.56	22.81	22.64
		1	5	22.68	22.77	22.50
		3	0	22.54	22.56	22.51
		3	1	22.73	22.82	22.70
		3	3	22.62	22.71	22.63
		6	0	21.90	22.01	22.05

*ERP (dBm) = Conducted Output Power (dBm) + Antenna Gain (dBi) - 2.15

7.1.3 LTE Band 7
Conducted Output Power (dBm)

BW	MCS Index	RB Size	RB Offset	Low	Mid	High
		Channel		20850	21100	21350
		Frequency (MHz)		2510	2535	2560
20M	QPSK	1	0	22.74	22.81	22.67
		1	50	22.68	22.75	22.67
		1	99	22.80	22.86	22.76
		50	0	21.73	21.80	21.79
		50	25	21.78	21.79	21.68
		50	50	21.56	21.70	21.64
		100	0	21.51	21.66	21.56
20M	16QAM	1	0	21.80	21.92	21.72
		1	50	21.76	21.86	21.69
		1	99	21.88	21.86	21.82
		50	0	20.83	20.90	20.86
		50	25	20.81	20.81	20.72
		50	50	20.57	20.75	20.73
		100	0	20.54	20.69	20.66
BW	MCS Index	RB Size	RB Offset	Low	Mid	High
		Channel		20825	21100	21375
		Frequency (MHz)		2507.5	2535	2562.5
15M	QPSK	1	0	22.74	22.80	22.73
		1	37	22.66	22.77	22.73
		1	74	22.64	22.70	22.69
		36	0	21.60	21.71	21.59
		36	19	21.69	21.83	21.69
		36	39	21.79	21.86	21.79
		75	0	21.62	21.77	21.71
15M	16QAM	1	0	21.84	21.86	21.74
		1	37	21.74	21.88	21.86
		1	74	21.66	21.75	21.71
		36	0	20.72	20.71	20.60
		36	19	20.78	20.84	20.74
		36	39	20.80	20.86	20.85
		75	0	20.69	20.83	20.80

BW	MCS Index	RB Size	RB Offset	Low	Mid	High
		Channel		20800	21100	21400
		Frequency (MHz)		2505	2535	2565
10M	QPSK	1	0	22.71	22.83	22.79
		1	24	22.70	22.76	22.66
		1	49	22.60	22.69	22.56
		25	0	21.55	21.70	21.55
		25	12	21.86	21.88	21.82
		25	25	21.62	21.77	21.72
		50	0	21.64	21.69	21.59
10M	16QAM	1	0	21.73	21.85	21.85
		1	24	21.77	21.86	21.73
		1	49	21.62	21.81	21.62
		25	0	20.68	20.81	20.68
		25	12	20.86	20.88	20.90
		25	25	20.66	20.87	20.85
		50	0	20.71	20.78	20.61
BW	MCS Index	RB Size	RB Offset	Low	Mid	High
		Channel		20775	21100	21425
		Frequency (MHz)		2502.5	2535	2567.5
5M	QPSK	1	0	22.40	22.51	22.50
		1	12	22.65	22.77	22.71
		1	24	22.42	22.51	22.48
		12	0	21.58	21.70	21.58
		12	6	21.68	21.78	21.69
		12	13	21.61	21.70	21.62
		25	0	21.61	21.65	21.63
5M	16QAM	1	0	21.52	21.62	21.50
		1	12	21.72	21.85	21.81
		1	24	21.50	21.55	21.49
		12	0	20.70	20.73	20.62
		12	6	20.79	20.83	20.76
		12	13	20.68	20.72	20.66
		25	0	20.70	20.72	20.63



EIRP Power (dBm)

BW	MCS Index	RB Size	RB Offset	Low	Mid	High
		Channel		20850	21100	21350
		Frequency (MHz)		2510	2535	2560
20M	QPSK	1	0	24.74	24.81	24.67
		1	50	24.68	24.75	24.67
		1	99	24.80	24.86	24.76
		50	0	23.73	23.80	23.79
		50	25	23.78	23.79	23.68
		50	50	23.56	23.70	23.64
		100	0	23.51	23.66	23.56
20M	16QAM	1	0	23.80	23.92	23.72
		1	50	23.76	23.86	23.69
		1	99	23.88	23.86	23.82
		50	0	22.83	22.90	22.86
		50	25	22.81	22.81	22.72
		50	50	22.57	22.75	22.73
		100	0	22.54	22.69	22.66
BW	MCS Index	RB Size	RB Offset	Low	Mid	High
		Channel		20825	21100	21375
		Frequency (MHz)		2507.5	2535	2562.5
15M	QPSK	1	0	24.74	24.80	24.73
		1	37	24.66	24.77	24.73
		1	74	24.64	24.70	24.69
		36	0	23.60	23.71	23.59
		36	19	23.69	23.83	23.69
		36	39	23.79	23.86	23.79
		75	0	23.62	23.77	23.71
15M	16QAM	1	0	23.84	23.86	23.74
		1	37	23.74	23.88	23.86
		1	74	23.66	23.75	23.71
		36	0	22.72	22.71	22.60
		36	19	22.78	22.84	22.74
		36	39	22.80	22.86	22.85
		75	0	22.69	22.83	22.80

*EIRP (dBm) = Conducted Output Power (dBm) + Antenna Gain (dBi)

BW	MCS Index	RB Size	RB Offset	Low	Mid	High
		Channel		20800	21100	21400
		Frequency (MHz)		2505	2535	2565
10M	QPSK	1	0	24.71	24.83	24.79
		1	24	24.70	24.76	24.66
		1	49	24.60	24.69	24.56
		25	0	23.55	23.70	23.55
		25	12	23.86	23.88	23.82
		25	25	23.62	23.77	23.72
		50	0	23.64	23.69	23.59
10M	16QAM	1	0	23.73	23.85	23.85
		1	24	23.77	23.86	23.73
		1	49	23.62	23.81	23.62
		25	0	22.68	22.81	22.68
		25	12	22.86	22.88	22.90
		25	25	22.66	22.87	22.85
		50	0	22.71	22.78	22.61
BW	MCS Index	RB Size	RB Offset	Low	Mid	High
		Channel		20775	21100	21425
		Frequency (MHz)		2502.5	2535	2567.5
5M	QPSK	1	0	24.40	24.51	24.50
		1	12	24.65	24.77	24.71
		1	24	24.42	24.51	24.48
		12	0	23.58	23.70	23.58
		12	6	23.68	23.78	23.69
		12	13	23.61	23.70	23.62
		25	0	23.61	23.65	23.63
5M	16QAM	1	0	23.52	23.62	23.50
		1	12	23.72	23.85	23.81
		1	24	23.50	23.55	23.49
		12	0	22.70	22.73	22.62
		12	6	22.79	22.83	22.76
		12	13	22.68	22.72	22.66
		25	0	22.70	22.72	22.63

*EIRP (dBm) = Conducted Output Power (dBm) + Antenna Gain (dBi)

7.1.4 LTE Band 26 (Part 22)
Conducted Output Power (dBm)

BW	MCS Index	RB Size	RB Offset	Low	Mid	High
		Channel		26865	26915	26965
		Frequency (MHz)		831.5	836.5	841.5
15M	QPSK	1	0	23.40	23.55	23.42
		1	37	23.48	23.50	23.39
		1	74	23.36	23.49	23.44
		36	0	22.49	22.55	22.40
		36	19	22.59	22.63	22.58
		36	39	22.46	22.61	22.49
		75	0	22.51	22.59	22.46
15M	16QAM	1	0	22.40	22.64	22.48
		1	37	22.44	22.56	22.50
		1	74	22.30	22.60	22.44
		36	0	21.50	21.58	21.53
		36	19	21.54	21.67	21.67
		36	39	21.35	21.73	21.56
		75	0	21.41	21.60	21.57
BW	MCS Index	RB Size	RB Offset	Low	Mid	High
		Channel		26840	26915	26990
		Frequency (MHz)		829	836.5	844
10M	QPSK	1	0	23.41	23.49	23.43
		1	24	23.42	23.55	23.53
		1	49	23.38	23.41	23.32
		25	0	22.56	22.60	22.59
		25	12	22.61	22.71	22.62
		25	25	22.70	22.73	22.69
		50	0	22.55	22.66	22.54
10M	16QAM	1	0	22.51	22.58	22.43
		1	24	22.49	22.67	22.64
		1	49	22.39	22.51	22.39
		25	0	21.56	21.71	21.67
		25	12	21.68	21.75	21.64
		25	25	21.83	21.82	21.72
		50	0	21.60	21.75	21.57

BW	MCS Index	RB Size	RB Offset	Low	Mid	High
		Channel		26815	26915	27015
		Frequency (MHz)		826.5	836.5	846.5
5M	QPSK	1	0	23.43	23.31	23.37
		1	12	23.56	23.50	23.41
		1	24	23.59	23.55	23.53
		12	0	22.56	22.42	22.41
		12	6	22.63	22.49	22.62
		12	13	22.61	22.51	22.60
		25	0	22.49	22.35	22.38
5M	16QAM	1	0	22.49	22.44	22.50
		1	12	22.60	22.63	22.44
		1	24	22.64	22.66	22.61
		12	0	21.65	21.45	21.42
		12	6	21.74	21.56	21.67
		12	13	21.71	21.56	21.61
		25	0	21.55	21.39	21.47
BW	MCS Index	RB Size	RB Offset	Low	Mid	High
		Channel		26805	26915	27025
		Frequency (MHz)		825.5	836.5	847.5
3M	QPSK	1	0	23.39	23.24	23.34
		1	7	23.41	23.38	23.26
		1	14	23.50	23.44	23.41
		8	0	22.44	22.40	22.40
		8	3	22.53	22.51	22.40
		8	7	22.52	22.51	22.50
		15	0	22.61	22.58	22.56
3M	16QAM	1	0	22.40	22.27	22.46
		1	7	22.51	22.43	22.38
		1	14	22.63	22.57	22.46
		8	0	21.51	21.45	21.46
		8	3	21.65	21.54	21.49
		8	7	21.55	21.63	21.53
		15	0	21.61	21.65	21.63



BW	MCS Index	RB Size	RB Offset	Low	Mid	High
		Channel		26797	26915	27033
		Frequency (MHz)		824.7	836.5	848.3
1.4M	QPSK	1	0	23.49	23.36	23.37
		1	2	23.30	23.17	23.17
		1	5	23.39	23.33	23.34
		3	0	23.44	23.33	23.37
		3	1	23.31	23.27	23.30
		3	3	23.40	23.27	23.28
		6	0	22.60	22.57	22.50
1.4M	16QAM	1	0	22.60	22.46	22.47
		1	2	22.40	22.28	22.25
		1	5	22.42	22.36	22.46
		3	0	22.52	22.38	22.40
		3	1	22.40	22.28	22.37
		3	3	22.45	22.33	22.29
		6	0	21.73	21.57	21.61

ERP Power (dBm)

BW	MCS Index	RB Size	RB Offset	Low	Mid	High
		Channel		26865	26915	26965
		Frequency (MHz)		831.5	836.5	841.5
15M	QPSK	1	0	23.25	23.40	23.27
		1	37	23.33	23.35	23.24
		1	74	23.21	23.34	23.29
		36	0	22.34	22.40	22.25
		36	19	22.44	22.48	22.43
		36	39	22.31	22.46	22.34
		75	0	22.36	22.44	22.31
15M	16QAM	1	0	22.25	22.49	22.33
		1	37	22.29	22.41	22.35
		1	74	22.15	22.45	22.29
		36	0	21.35	21.43	21.38
		36	19	21.39	21.52	21.52
		36	39	21.20	21.58	21.41
		75	0	21.26	21.45	21.42
BW	MCS Index	RB Size	RB Offset	Low	Mid	High
		Channel		26840	26915	26990
		Frequency (MHz)		829	836.5	844
10M	QPSK	1	0	23.26	23.34	23.28
		1	24	23.27	23.40	23.38
		1	49	23.23	23.26	23.17
		25	0	22.41	22.45	22.44
		25	12	22.46	22.56	22.47
		25	25	22.55	22.58	22.54
		50	0	22.40	22.51	22.39
10M	16QAM	1	0	22.36	22.43	22.28
		1	24	22.34	22.52	22.49
		1	49	22.24	22.36	22.24
		25	0	21.41	21.56	21.52
		25	12	21.53	21.60	21.49
		25	25	21.68	21.67	21.57
		50	0	21.45	21.60	21.42

*ERP (dBm) = Conducted Output Power (dBm) + Antenna Gain (dBi) - 2.15

BW	MCS Index	RB Size	RB Offset	Low	Mid	High
		Channel		26815	26915	27015
		Frequency (MHz)		826.5	836.5	846.5
5M	QPSK	1	0	23.28	23.16	23.22
		1	12	23.41	23.35	23.26
		1	24	23.44	23.40	23.38
		12	0	22.41	22.27	22.26
		12	6	22.48	22.34	22.47
		12	13	22.46	22.36	22.45
		25	0	22.34	22.20	22.23
5M	16QAM	1	0	22.34	22.29	22.35
		1	12	22.45	22.48	22.29
		1	24	22.49	22.51	22.46
		12	0	21.50	21.30	21.27
		12	6	21.59	21.41	21.52
		12	13	21.56	21.41	21.46
		25	0	21.40	21.24	21.32
BW	MCS Index	RB Size	RB Offset	Low	Mid	High
		Channel		26805	26915	27025
		Frequency (MHz)		825.5	836.5	847.5
3M	QPSK	1	0	23.24	23.09	23.19
		1	7	23.26	23.23	23.11
		1	14	23.35	23.29	23.26
		8	0	22.29	22.25	22.25
		8	3	22.38	22.36	22.25
		8	7	22.37	22.36	22.35
		15	0	22.46	22.43	22.41
3M	16QAM	1	0	22.25	22.12	22.31
		1	7	22.36	22.28	22.23
		1	14	22.48	22.42	22.31
		8	0	21.36	21.30	21.31
		8	3	21.50	21.39	21.34
		8	7	21.40	21.48	21.38
		15	0	21.46	21.50	21.48

*ERP (dBm) = Conducted Output Power (dBm) + Antenna Gain (dBi) - 2.15

BW	MCS Index	RB Size	RB Offset	Low	Mid	High
		Channel		26797	26915	27033
		Frequency (MHz)		824.7	836.5	848.3
1.4M	QPSK	1	0	23.34	23.21	23.22
		1	2	23.15	23.02	23.02
		1	5	23.24	23.18	23.19
		3	0	23.29	23.18	23.22
		3	1	23.16	23.12	23.15
		3	3	23.25	23.12	23.13
		6	0	22.45	22.42	22.35
1.4M	16QAM	1	0	22.45	22.31	22.32
		1	2	22.25	22.13	22.10
		1	5	22.27	22.21	22.31
		3	0	22.37	22.23	22.25
		3	1	22.25	22.13	22.22
		3	3	22.30	22.18	22.14
		6	0	21.58	21.42	21.46

*ERP (dBm) = Conducted Output Power (dBm) + Antenna Gain (dBi) - 2.15

7.1.5 LTE Band 26 (Part 90)
Conducted Output Power (dBm)

BW	MCS Index	RB Size	RB Offset	Mid		
		Channel		26740		
		Frequency (MHz)		819		
10M	QPSK	1	0	23.37		
		1	24	23.51		
		1	49	23.26		
		25	0	22.56		
		25	12	22.61		
		25	25	22.67		
		50	0	22.58		
10M	16QAM	1	0	22.37		
		1	24	22.54		
		1	49	22.28		
		25	0	21.62		
		25	12	21.71		
		25	25	21.79		
		50	0	21.69		
BW	MCS Index	RB Size	RB Offset	Low	Mid	High
		Channel		26715	26740	26765
		Frequency (MHz)		816.5	819	821.5
5M	QPSK	1	0	23.34	23.41	23.37
		1	12	23.47	23.45	23.52
		1	24	23.52	23.50	23.58
		12	0	22.51	22.42	22.46
		12	6	22.56	22.57	22.60
		12	13	22.57	22.53	22.47
		25	0	22.46	22.40	22.38
5M	16QAM	1	0	22.43	22.45	22.38
		1	12	22.60	22.46	22.58
		1	24	22.64	22.61	22.62
		12	0	21.53	21.49	21.54
		12	6	21.62	21.60	21.73
		12	13	21.64	21.64	21.51
		25	0	21.53	21.41	22.38

BW	MCS Index	RB Size	RB Offset	Low	Mid	High
		Channel		26705	26740	26775
		Frequency (MHz)		815.5	819	822.5
3M	QPSK	1	0	23.38	23.26	23.33
		1	7	23.36	23.26	23.30
		1	14	23.47	23.38	23.45
		8	0	22.32	22.29	22.32
		8	3	22.40	22.49	22.49
		8	7	22.40	22.42	22.49
		15	0	22.54	22.58	22.60
3M	16QAM	1	0	22.38	22.26	22.44
		1	7	22.40	22.32	22.31
		1	14	22.48	22.46	22.46
		8	0	21.38	21.31	21.42
		8	3	21.51	21.50	21.60
		8	7	21.46	21.42	21.60
		15	0	21.67	21.63	22.60
BW	MCS Index	RB Size	RB Offset	Low	Mid	High
		Channel		26697	26740	26783
		Frequency (MHz)		814.7	819	823.3
1.4M	QPSK	1	0	23.36	23.48	23.37
		1	2	23.27	23.17	23.28
		1	5	23.29	23.33	23.37
		3	0	23.37	23.32	23.41
		3	1	23.29	23.30	23.27
		3	3	23.28	23.27	23.38
		6	0	22.56	22.49	22.52
1.4M	16QAM	1	0	22.43	22.61	22.39
		1	2	22.27	22.19	22.29
		1	5	22.32	22.39	22.49
		3	0	22.45	22.37	22.43
		3	1	22.31	22.38	22.30
		3	3	22.31	22.33	22.50
		6	0	21.65	21.60	22.52

ERP Power (dBm)

BW	MCS Index	RB Size	RB Offset	Mid		
		Channel		26740		
		Frequency (MHz)		819		
10M	QPSK	1	0	23.22		
		1	24	23.36		
		1	49	23.11		
		25	0	22.41		
		25	12	22.46		
		25	25	22.52		
		50	0	22.43		
10M	16QAM	1	0	22.22		
		1	24	22.39		
		1	49	22.13		
		25	0	21.47		
		25	12	21.56		
		25	25	21.64		
		50	0	21.54		
BW	MCS Index	RB Size	RB Offset	Low	Mid	High
		Channel		26715	26740	26765
		Frequency (MHz)		816.5	819	821.5
5M	QPSK	1	0	23.19	23.26	23.22
		1	12	23.32	23.30	23.37
		1	24	23.37	23.35	23.43
		12	0	22.36	22.27	22.31
		12	6	22.41	22.42	22.45
		12	13	22.42	22.38	22.32
		25	0	22.31	22.25	22.23
5M	16QAM	1	0	22.28	22.30	22.23
		1	12	22.45	22.31	22.43
		1	24	22.49	22.46	22.47
		12	0	21.38	21.34	21.39
		12	6	21.47	21.45	21.58
		12	13	21.49	21.49	21.36
		25	0	21.38	21.26	22.23

*ERP (dBm) = Conducted Output Power (dBm) + Antenna Gain (dBi) - 2.15

BW	MCS Index	RB Size	RB Offset	Low	Mid	High
		Channel		26705	26740	26775
		Frequency (MHz)		815.5	819	822.5
3M	QPSK	1	0	23.23	23.11	23.18
		1	7	23.21	23.11	23.15
		1	14	23.32	23.23	23.30
		8	0	22.17	22.14	22.17
		8	3	22.25	22.34	22.34
		8	7	22.25	22.27	22.34
		15	0	22.39	22.43	22.45
3M	16QAM	1	0	22.23	22.11	22.29
		1	7	22.25	22.17	22.16
		1	14	22.33	22.31	22.31
		8	0	21.23	21.16	21.27
		8	3	21.36	21.35	21.45
		8	7	21.31	21.27	21.45
		15	0	21.52	21.48	22.45
BW	MCS Index	RB Size	RB Offset	Low	Mid	High
		Channel		26697	26740	26783
		Frequency (MHz)		814.7	819	823.3
1.4M	QPSK	1	0	23.21	23.33	23.22
		1	2	23.12	23.02	23.13
		1	5	23.14	23.18	23.22
		3	0	23.22	23.17	23.26
		3	1	23.14	23.15	23.12
		3	3	23.13	23.12	23.23
		6	0	22.41	22.34	22.37
1.4M	16QAM	1	0	22.28	22.46	22.24
		1	2	22.12	22.04	22.14
		1	5	22.17	22.24	22.34
		3	0	22.30	22.22	22.28
		3	1	22.16	22.23	22.15
		3	3	22.16	22.18	22.35
		6	0	21.50	21.45	22.37

*ERP (dBm) = Conducted Output Power (dBm) + Antenna Gain (dBi) - 2.15

7.1.6 LTE Band 38

Conducted Output Power (dBm)

BW	MCS Index	RB Size	RB Offset	Low	Mid	High
		Channel		37850	38000	38150
		Frequency (MHz)		2580	2595	2610
20M	QPSK	1	0	22.59	22.61	22.56
		1	50	22.07	22.16	22.09
		1	99	22.50	22.51	22.38
		50	0	21.28	21.39	21.27
		50	25	21.31	21.33	21.24
		50	50	21.33	21.36	21.35
		100	0	21.30	21.40	21.27
20M	16QAM	1	0	21.71	21.66	21.62
		1	50	21.10	21.26	21.12
		1	99	21.62	21.57	21.48
		50	0	20.28	20.51	20.28
		50	25	20.42	20.34	20.28
		50	50	20.34	20.42	20.38
		100	0	20.33	20.41	20.29
BW	MCS Index	RB Size	RB Offset	Low	Mid	High
		Channel		37825	38000	38175
		Frequency (MHz)		2577.5	2595	2612.5
15M	QPSK	1	0	22.33	22.44	22.29
		1	37	22.33	22.41	22.37
		1	74	22.28	22.36	22.31
		36	0	21.24	21.31	21.25
		36	19	21.28	21.35	21.30
		36	39	21.17	21.30	21.16
		75	0	21.19	21.29	21.25
15M	16QAM	1	0	21.37	21.56	21.37
		1	37	21.36	21.50	21.49
		1	74	21.34	21.46	21.32
		36	0	20.32	20.41	20.33
		36	19	20.33	20.42	20.38
		36	39	20.23	20.39	20.23
		75	0	20.32	20.32	20.32

BW	MCS Index	RB Size	RB Offset	Low	Mid	High
		Channel		37800	38000	38200
		Frequency (MHz)		2575	2595	2615
10M	QPSK	1	0	22.21	22.31	22.22
		1	24	22.26	22.40	22.34
		1	49	22.29	22.36	22.29
		25	0	21.20	21.33	21.20
		25	12	21.19	21.29	21.23
		25	25	21.30	21.43	21.31
		50	0	21.38	21.44	21.35
10M	16QAM	1	0	21.28	21.40	21.28
		1	24	21.37	21.47	21.38
		1	49	21.42	21.37	21.41
		25	0	20.23	20.44	20.24
		25	12	20.19	20.35	20.29
		25	25	20.31	20.52	20.38
		50	0	20.39	20.49	20.37
BW	MCS Index	RB Size	RB Offset	Low	Mid	High
		Channel		37775	38000	38225
		Frequency (MHz)		2572.5	2595	2617.5
5M	QPSK	1	0	22.15	22.21	22.15
		1	12	22.38	22.39	22.32
		1	24	22.21	22.23	22.14
		12	0	21.33	21.34	21.30
		12	6	21.37	21.50	21.37
		12	13	21.43	21.46	21.43
		25	0	21.30	21.43	21.31
5M	16QAM	1	0	21.15	21.29	21.20
		1	12	21.45	21.42	21.37
		1	24	21.23	21.33	21.14
		12	0	20.36	20.39	20.38
		12	6	20.50	20.59	20.44
		12	13	20.48	20.52	20.43
		25	0	20.37	20.43	20.32



EIRP Power (dBm)

BW	MCS Index	RB Size	RB Offset	Low	Mid	High
		Channel		37850	38000	38150
		Frequency (MHz)		2580	2595	2610
20M	QPSK	1	0	24.59	24.61	24.56
		1	50	24.07	24.16	24.09
		1	99	24.50	24.51	24.38
		50	0	23.28	23.39	23.27
		50	25	23.31	23.33	23.24
		50	50	23.33	23.36	23.35
		100	0	23.30	23.40	23.27
20M	16QAM	1	0	23.71	23.66	23.62
		1	50	23.10	23.26	23.12
		1	99	23.62	23.57	23.48
		50	0	22.28	22.51	22.28
		50	25	22.42	22.34	22.28
		50	50	22.34	22.42	22.38
		100	0	22.33	22.41	22.29
BW	MCS Index	RB Size	RB Offset	Low	Mid	High
		Channel		37825	38000	38175
		Frequency (MHz)		2577.5	2595	2612.5
15M	QPSK	1	0	24.33	24.44	24.29
		1	37	24.33	24.41	24.37
		1	74	24.28	24.36	24.31
		36	0	23.24	23.31	23.25
		36	19	23.28	23.35	23.30
		36	39	23.17	23.30	23.16
		75	0	23.19	23.29	23.25
15M	16QAM	1	0	23.37	23.56	23.37
		1	37	23.36	23.50	23.49
		1	74	23.34	23.46	23.32
		36	0	22.32	22.41	22.33
		36	19	22.33	22.42	22.38
		36	39	22.23	22.39	22.23
		75	0	22.32	22.32	22.32

*EIRP (dBm) = Conducted Output Power (dBm) + Antenna Gain (dBi)

BW	MCS Index	RB Size	RB Offset	Low	Mid	High
		Channel		37800	38000	38200
		Frequency (MHz)		2575	2595	2615
10M	QPSK	1	0	24.21	24.31	24.22
		1	24	24.26	24.40	24.34
		1	49	24.29	24.36	24.29
		25	0	23.20	23.33	23.20
		25	12	23.19	23.29	23.23
		25	25	23.30	23.43	23.31
		50	0	23.38	23.44	23.35
10M	16QAM	1	0	23.28	23.40	23.28
		1	24	23.37	23.47	23.38
		1	49	23.42	23.37	23.41
		25	0	22.23	22.44	22.24
		25	12	22.19	22.35	22.29
		25	25	22.31	22.52	22.38
		50	0	22.39	22.49	22.37
BW	MCS Index	RB Size	RB Offset	Low	Mid	High
		Channel		37775	38000	38225
		Frequency (MHz)		2572.5	2595	2617.5
5M	QPSK	1	0	24.15	24.21	24.15
		1	12	24.38	24.39	24.32
		1	24	24.21	24.23	24.14
		12	0	23.33	23.34	23.30
		12	6	23.37	23.50	23.37
		12	13	23.43	23.46	23.43
		25	0	23.30	23.43	23.31
5M	16QAM	1	0	23.15	23.29	23.20
		1	12	23.45	23.42	23.37
		1	24	23.23	23.33	23.14
		12	0	22.36	22.39	22.38
		12	6	22.50	22.59	22.44
		12	13	22.48	22.52	22.43
		25	0	22.37	22.43	22.32

*EIRP (dBm) = Conducted Output Power (dBm) + Antenna Gain (dBi)

7.1.7 LTE Band 41

Conducted Output Power (dBm)

BW	MCS Index	RB Size	RB Offset	Low	Mid	High
		Channel		40340	40690	41140
		Frequency (MHz)		2565	2600	2645
20M	QPSK	1	0	22.30	22.31	22.20
		1	50	22.01	22.16	22.06
		1	99	22.04	22.10	21.99
		50	0	21.17	21.23	21.15
		50	25	21.35	21.45	21.44
		50	50	21.34	21.49	21.37
		100	0	21.26	21.39	21.33
20M	16QAM	1	0	21.33	21.42	21.27
		1	50	21.09	21.17	21.12
		1	99	21.04	21.23	21.01
		50	0	20.29	20.27	20.16
		50	25	20.41	20.55	20.49
		50	50	20.46	20.58	20.38
		100	0	20.32	20.52	20.44
BW	MCS Index	RB Size	RB Offset	Low	Mid	High
		Channel		40315	40690	41165
		Frequency (MHz)		2562.5	2600	2647.5
15M	QPSK	1	0	21.97	22.00	21.87
		1	37	21.98	22.10	22.02
		1	74	22.13	22.19	22.18
		36	0	21.24	21.29	21.20
		36	19	21.24	21.32	21.28
		36	39	21.39	21.40	21.37
		75	0	21.31	21.33	21.23
15M	16QAM	1	0	21.01	21.01	20.88
		1	37	21.01	21.19	21.06
		1	74	21.22	21.30	21.18
		36	0	20.25	20.31	20.30
		36	19	20.29	20.43	20.40
		36	39	20.45	20.51	20.45
		75	0	20.32	20.39	20.29

BW	MCS Index	RB Size	RB Offset	Low	Mid	High
		Channel		40290	40690	41190
		Frequency (MHz)		2560	2600	2650
10M	QPSK	1	0	22.09	22.13	22.08
		1	24	21.97	22.11	21.99
		1	49	22.29	22.30	22.27
		25	0	21.21	21.30	21.20
		25	12	21.20	21.33	21.22
		25	25	21.48	21.50	21.42
		50	0	21.29	21.44	21.31
10M	16QAM	1	0	21.10	21.13	21.18
		1	24	20.97	21.19	21.01
		1	49	21.40	21.43	21.40
		25	0	20.29	20.40	20.22
		25	12	20.23	20.33	20.28
		25	25	20.49	20.61	20.45
		50	0	20.37	20.45	20.44
BW	MCS Index	RB Size	RB Offset	Low	Mid	High
		Channel		40265	40690	41215
		Frequency (MHz)		2557.5	2600	2652.5
5M	QPSK	1	0	22.10	22.20	22.13
		1	12	22.14	22.21	22.14
		1	24	22.08	22.11	21.99
		12	0	21.13	21.19	21.14
		12	6	21.04	21.10	21.05
		12	13	21.18	21.33	21.28
		25	0	21.16	21.28	21.19
5M	16QAM	1	0	21.12	21.27	21.25
		1	12	21.19	21.27	21.14
		1	24	21.12	21.19	21.00
		12	0	20.21	20.26	20.26
		12	6	20.17	20.19	20.07
		12	13	20.23	20.35	20.30
		25	0	20.17	20.39	20.29



EIRP Power (dBm)

BW	MCS Index	RB Size	RB Offset	Low	Mid	High
		Channel		40340	40690	41140
		Frequency (MHz)		2565	2600	2645
20M	QPSK	1	0	24.30	24.31	24.20
		1	50	24.01	24.16	24.06
		1	99	24.04	24.10	23.99
		50	0	23.17	23.23	23.15
		50	25	23.35	23.45	23.44
		50	50	23.34	23.49	23.37
		100	0	23.26	23.39	23.33
20M	16QAM	1	0	23.33	23.42	23.27
		1	50	23.09	23.17	23.12
		1	99	23.04	23.23	23.01
		50	0	22.29	22.27	22.16
		50	25	22.41	22.55	22.49
		50	50	22.46	22.58	22.38
		100	0	22.32	22.52	22.44
BW	MCS Index	RB Size	RB Offset	Low	Mid	High
		Channel		40315	40690	41165
		Frequency (MHz)		2562.5	2600	2647.5
15M	QPSK	1	0	23.97	24.00	23.87
		1	37	23.98	24.10	24.02
		1	74	24.13	24.19	24.18
		36	0	23.24	23.29	23.20
		36	19	23.24	23.32	23.28
		36	39	23.39	23.40	23.37
		75	0	23.31	23.33	23.23
15M	16QAM	1	0	23.01	23.01	22.88
		1	37	23.01	23.19	23.06
		1	74	23.22	23.30	23.18
		36	0	22.25	22.31	22.30
		36	19	22.29	22.43	22.40
		36	39	22.45	22.51	22.45
		75	0	22.32	22.39	22.29

*EIRP (dBm) = Conducted Output Power (dBm) + Antenna Gain (dBi)

BW	MCS Index	RB Size	RB Offset	Low	Mid	High
		Channel		40290	40690	41190
		Frequency (MHz)		2560	2600	2650
10M	QPSK	1	0	24.09	24.13	24.08
		1	24	23.97	24.11	23.99
		1	49	24.29	24.30	24.27
		25	0	23.21	23.30	23.20
		25	12	23.20	23.33	23.22
		25	25	23.48	23.50	23.42
		50	0	23.29	23.44	23.31
10M	16QAM	1	0	23.10	23.13	23.18
		1	24	22.97	23.19	23.01
		1	49	23.40	23.43	23.40
		25	0	22.29	22.40	22.22
		25	12	22.23	22.33	22.28
		25	25	22.49	22.61	22.45
		50	0	22.37	22.45	22.44
BW	MCS Index	RB Size	RB Offset	Low	Mid	High
		Channel		40265	40690	41215
		Frequency (MHz)		2557.5	2600	2652.5
5M	QPSK	1	0	24.10	24.20	24.13
		1	12	24.14	24.21	24.14
		1	24	24.08	24.11	23.99
		12	0	23.13	23.19	23.14
		12	6	23.04	23.10	23.05
		12	13	23.18	23.33	23.28
		25	0	23.16	23.28	23.19
5M	16QAM	1	0	23.12	23.27	23.25
		1	12	23.19	23.27	23.14
		1	24	23.12	23.19	23.00
		12	0	22.21	22.26	22.26
		12	6	22.17	22.19	22.07
		12	13	22.23	22.35	22.30
		25	0	22.17	22.39	22.29

*EIRP (dBm) = Conducted Output Power (dBm) + Antenna Gain (dBi)

7.2 Modulation Characteristics

Input Power:	3.8 Vdc	Environmental Conditions:	27°C, 68% RH	Tested By:	Noah Chang
--------------	---------	---------------------------	--------------	------------	------------

7.2.1 WCDMA Band 5

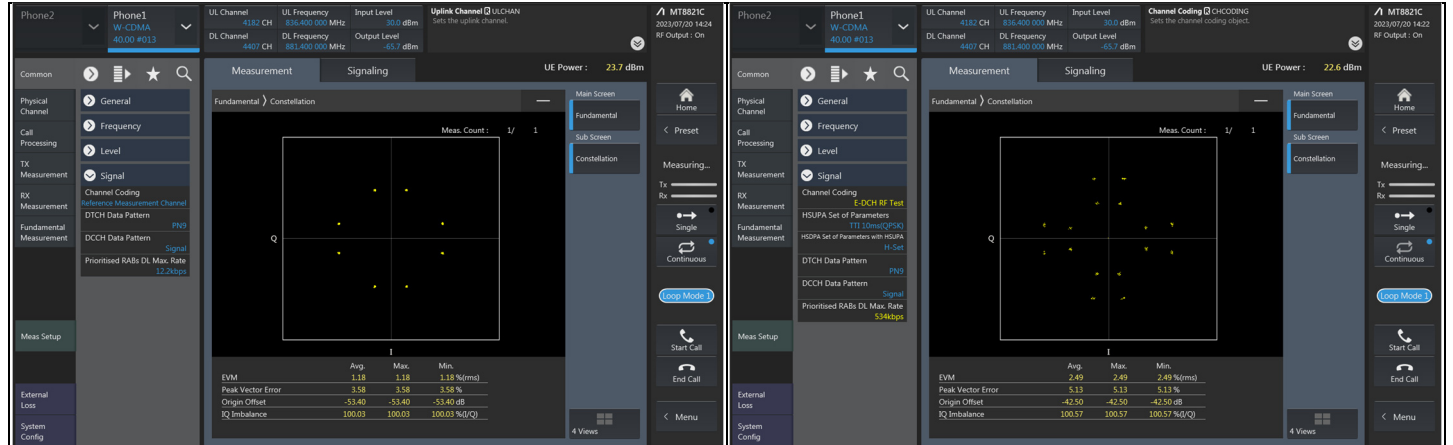

WCDMA CH 4182 (836.4 MHz)

HSPA CH 4182 (836.4 MHz)

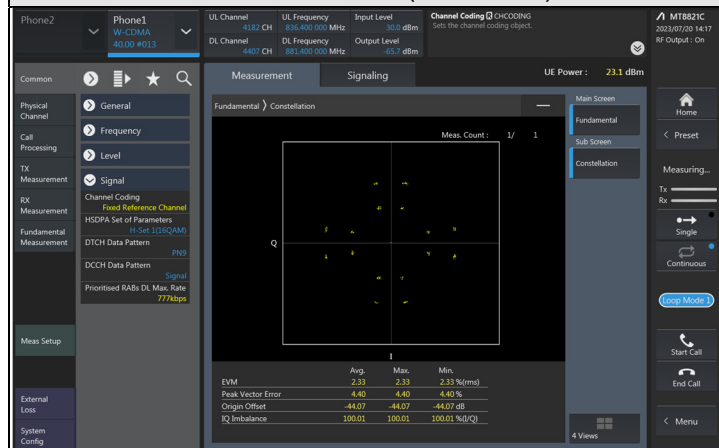

HSDPA CH 4182 (836.4 MHz)

7.2.2 LTE Band 5

LTE Band 5, Channel Bandwidth: 10 MHz

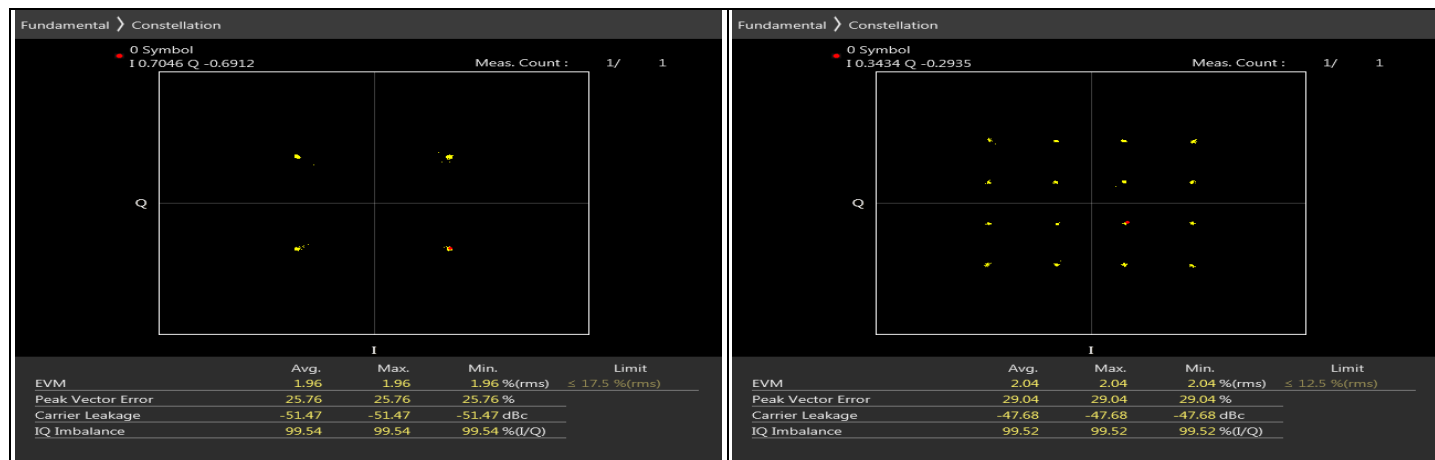

7.2.3 LTE Band 7

LTE Band 7, Channel Bandwidth: 20 MHz

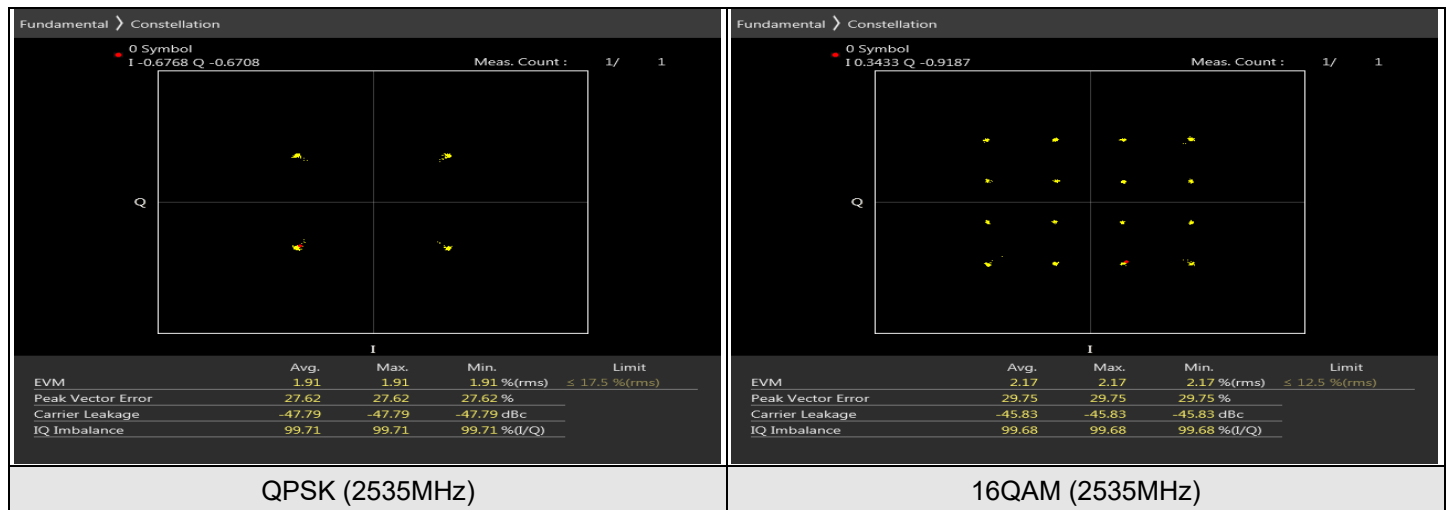

7.2.4 LTE Band 26 (Part 22)

LTE Band 26, Channel Bandwidth: 15 MHz

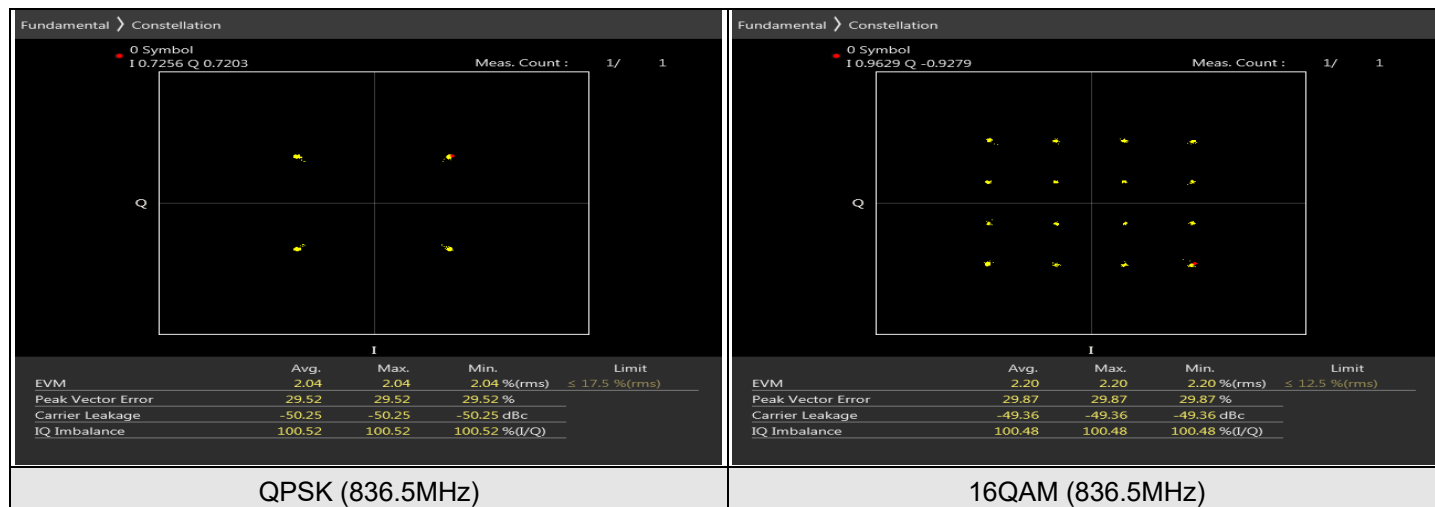

7.2.5 LTE Band 26 (Part 90)

LTE Band 26, Channel Bandwidth: 10 MHz

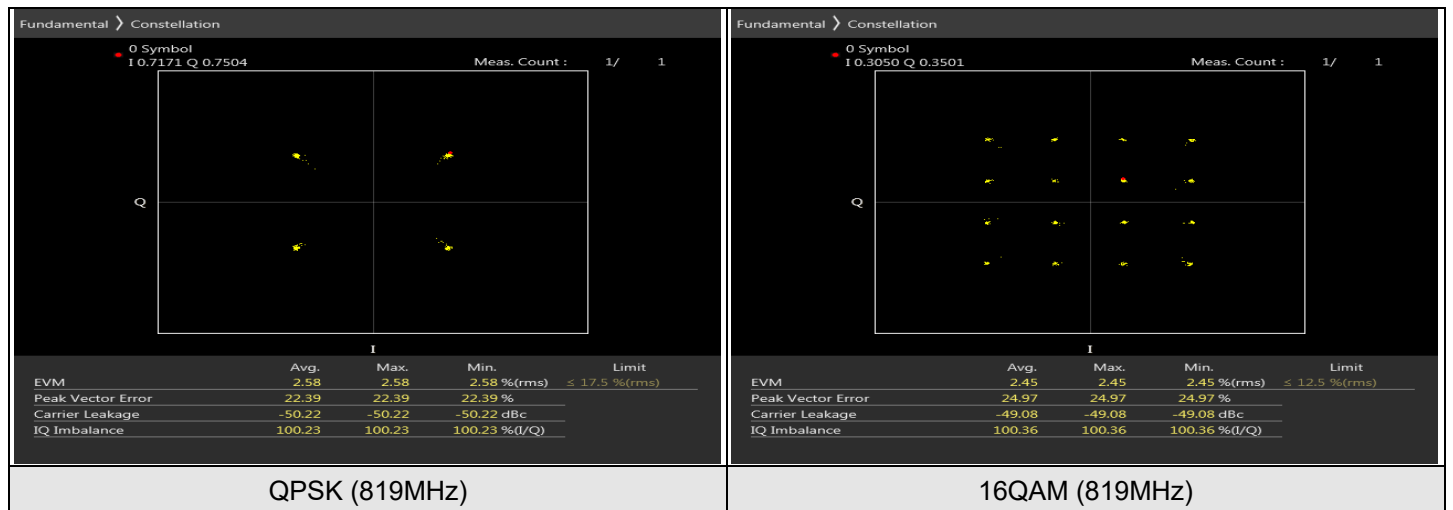

7.2.6 LTE Band 38

LTE Band 38, Channel Bandwidth: 20 MHz

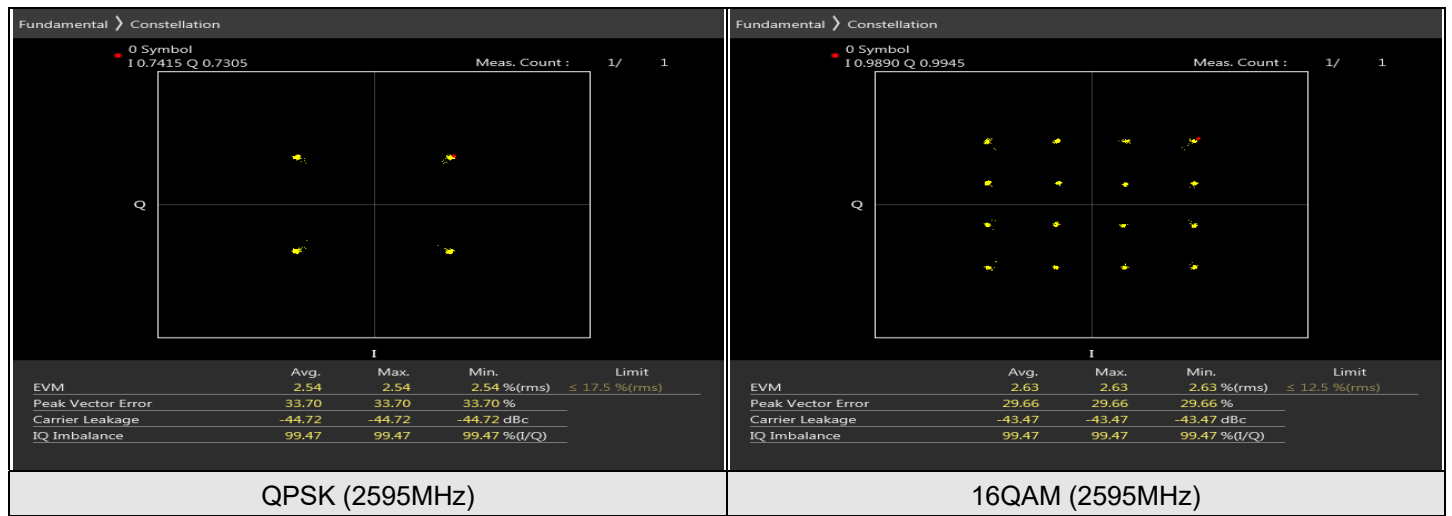

7.2.7 LTE Band 41

LTE Band 41, Channel Bandwidth: 20 MHz

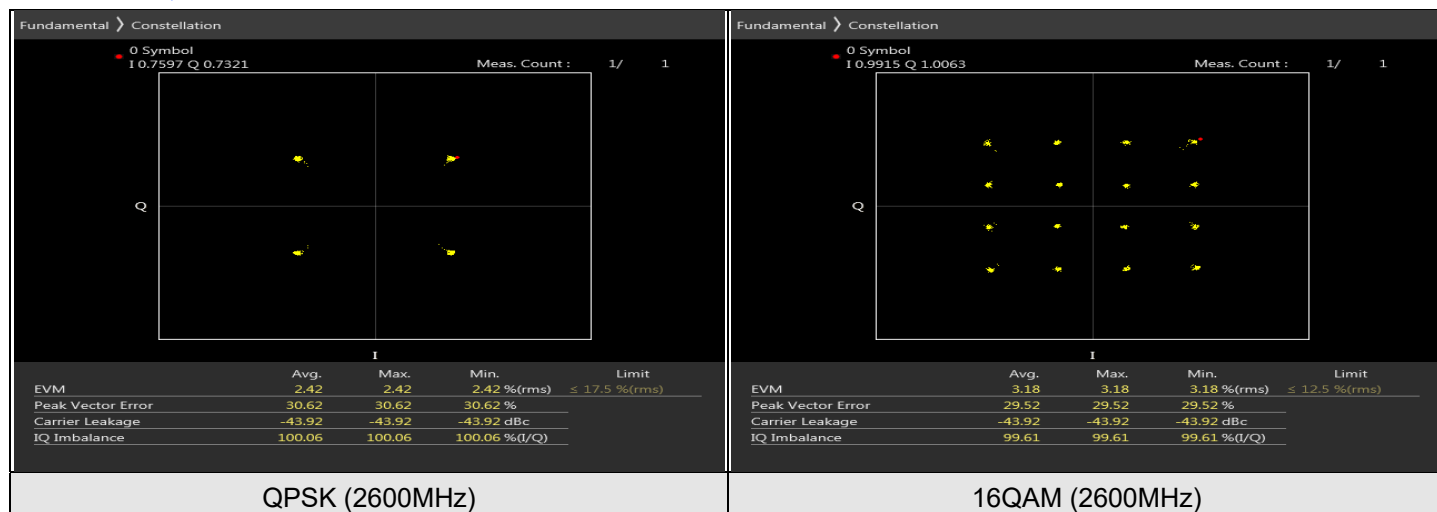

7.3 Peak to Average Ratio

Input Power:	3.8 Vdc	Environmental Conditions:	27°C, 68% RH	Tested By:	Noah Chang
--------------	---------	---------------------------	--------------	------------	------------

7.3.1 WCDMA Band 5

Modulation	Channel	Frequency (MHz)	Measurement Value(dB)	Limit (dB)	Result
WCDMA	4132	826.4	3.38	13	Pass
WCDMA	4182	836.4	2.92	13	Pass
WCDMA	4223	846.6	3.27	13	Pass
HSDPA	4132	826.4	3.88	13	Pass
HSDPA	4182	836.4	4.01	13	Pass
HSDPA	4223	846.6	3.95	13	Pass
HSUPA	4132	826.4	3.86	13	Pass
HSUPA	4182	836.4	3.96	13	Pass
HSUPA	4223	846.6	3.92	13	Pass

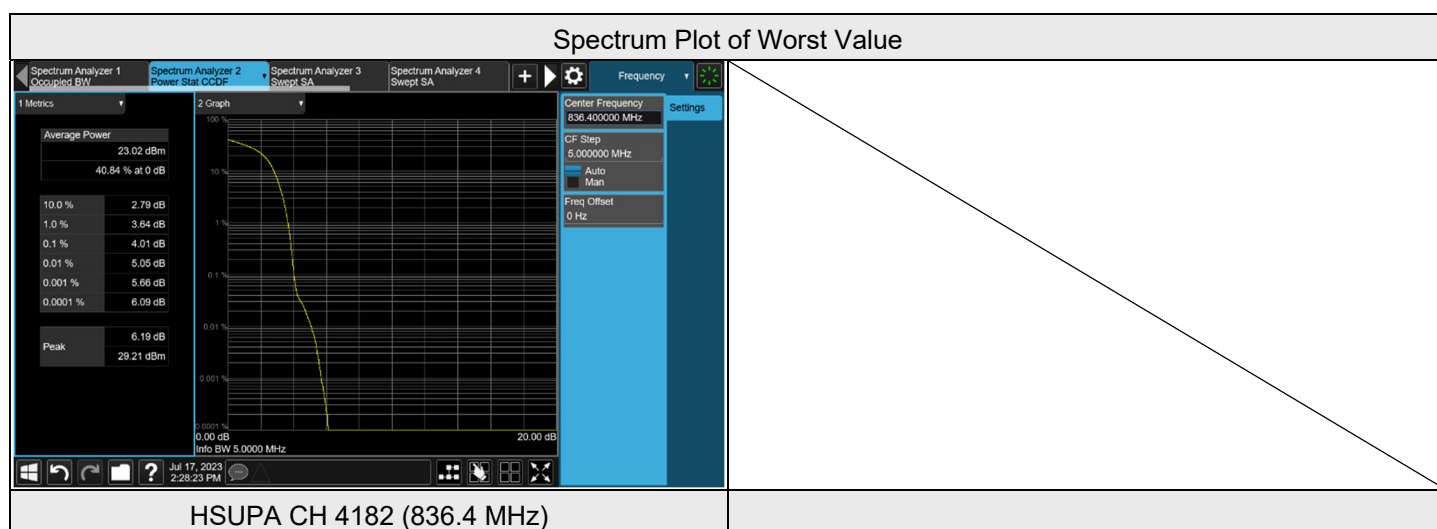

7.3.2 LTE Band 5

LTE Band 5, Channel Bandwidth: 1.4 MHz

Test Condition	Channel	Frequency (MHz)	Measure. Value(dB)	Limit dB	Result
QPSK	20407	824.7	4.84	13	PASS
QPSK	20525	836.5	5.09	13	PASS
QPSK	20643	848.3	4.10	13	PASS
16QAM	20407	824.7	5.74	13	PASS
16QAM	20525	836.5	6.04	13	PASS
16QAM	20643	848.3	5.13	13	PASS

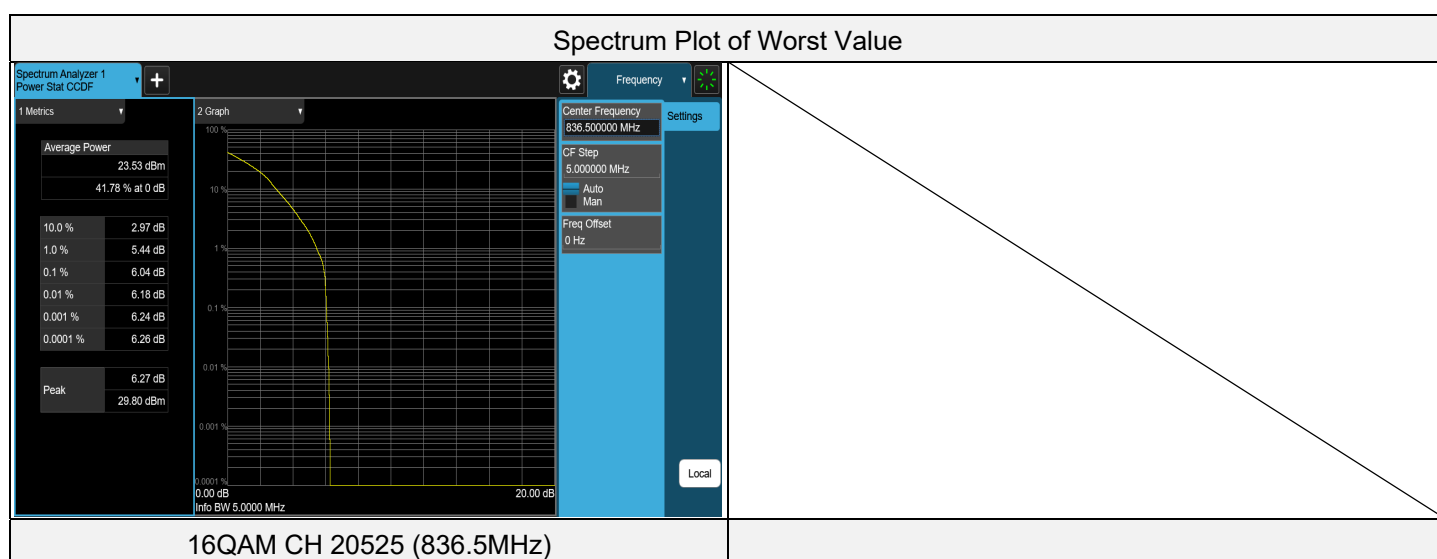

LTE Band 5, Channel Bandwidth: 3 MHz

Test Condition	Channel	Frequency (MHz)	Measure. Value(dB)	Limit dB	Result
QPSK	20415	825.5	4.84	13	PASS
QPSK	20525	836.5	5.12	13	PASS
QPSK	20635	847.5	4.22	13	PASS
16QAM	20415	825.5	5.75	13	PASS
16QAM	20525	836.5	6.01	13	PASS
16QAM	20635	847.5	5.27	13	PASS

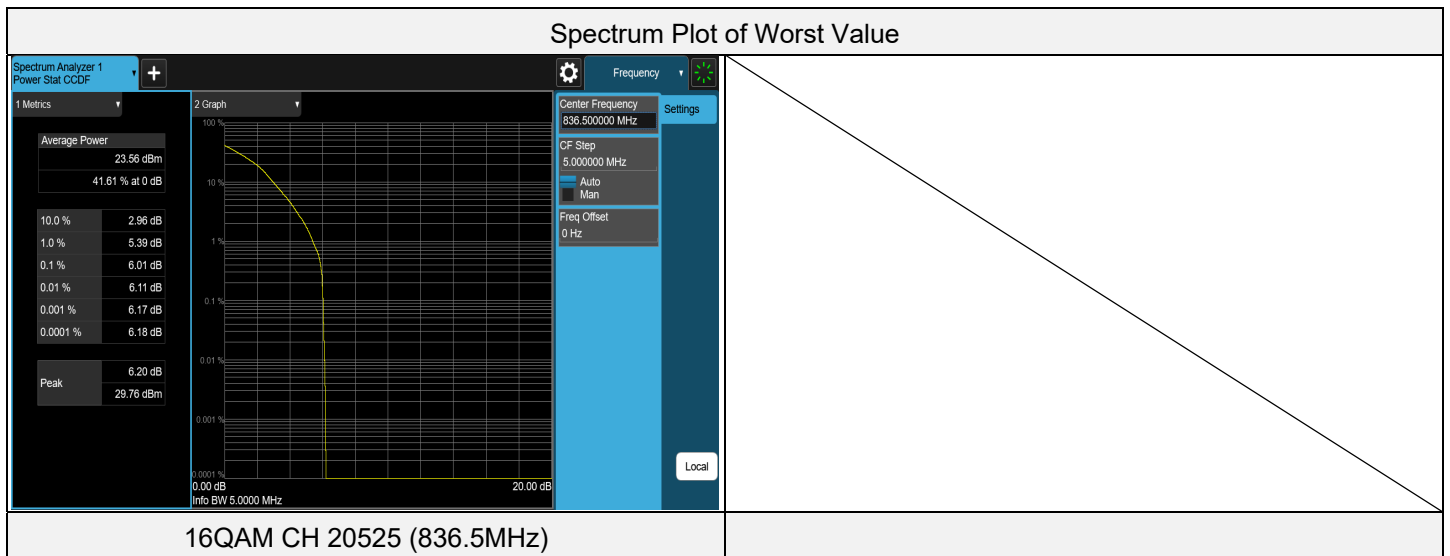

LTE Band 5, Channel Bandwidth: 5 MHz

Test Condition	Channel	Frequency (MHz)	Measure. Value(dB)	Limit dB	Result
QPSK	20425	826.5	4.79	13	PASS
QPSK	20525	836.5	5.03	13	PASS
QPSK	20625	846.5	4.58	13	PASS
16QAM	20425	826.5	5.68	13	PASS
16QAM	20525	836.5	5.95	13	PASS
16QAM	20625	846.5	5.51	13	PASS

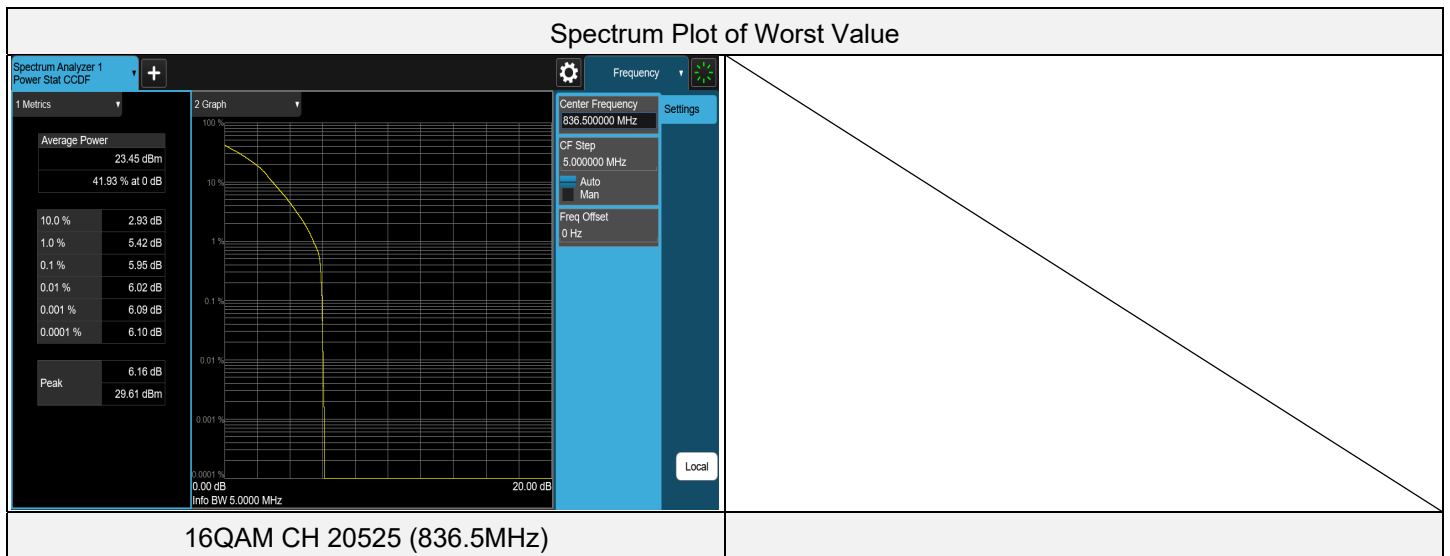

LTE Band 5, Channel Bandwidth: 10 MHz

Test Condition	Channel	Frequency (MHz)	Measure. Value(dB)	Limit dB	Result
QPSK	20450	829	4.79	13	PASS
QPSK	20525	836.5	4.98	13	PASS
QPSK	20600	844	4.95	13	PASS
16QAM	20450	829	5.69	13	PASS
16QAM	20525	836.5	5.89	13	PASS
16QAM	20600	844	5.91	13	PASS

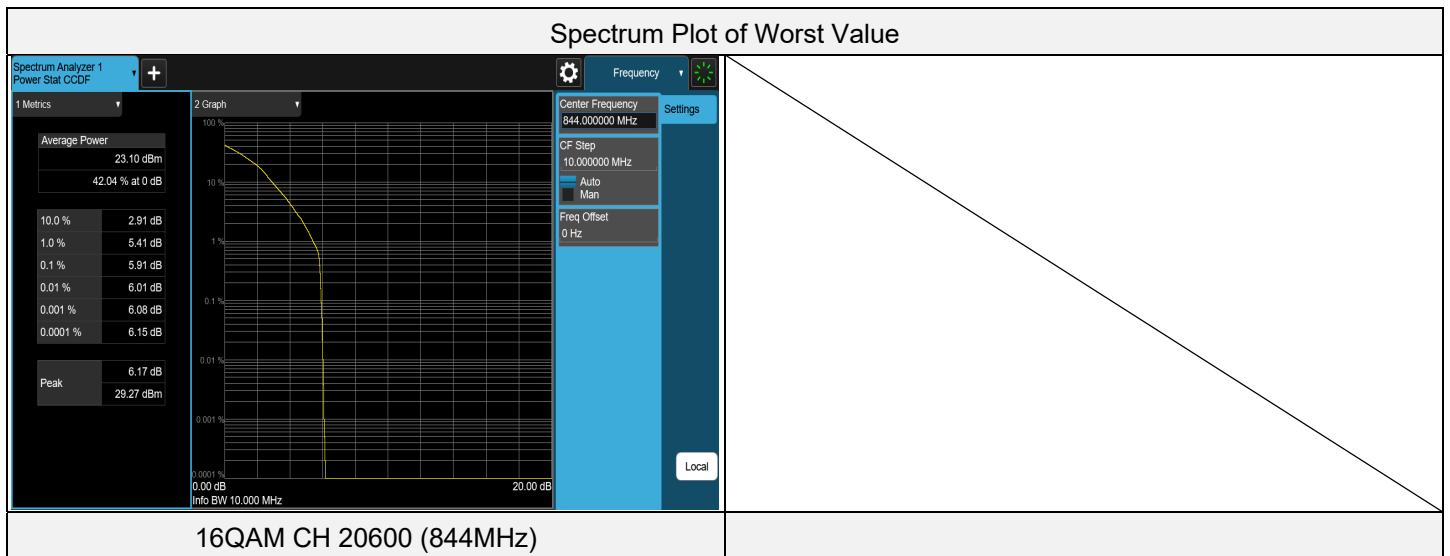

7.3.3 LTE Band 7

LTE Band 7, Channel Bandwidth: 5 MHz

Test Condition	Channel	Frequency (MHz)	Measure. Value(dB)	Limit dB	Result
QPSK	20775	2502.5	4.22	13	PASS
QPSK	21100	2535	4.41	13	PASS
QPSK	21425	2567.5	4.14	13	PASS
16QAM	20775	2502.5	5.08	13	PASS
16QAM	21100	2535	5.37	13	PASS
16QAM	21425	2567.5	4.97	13	PASS

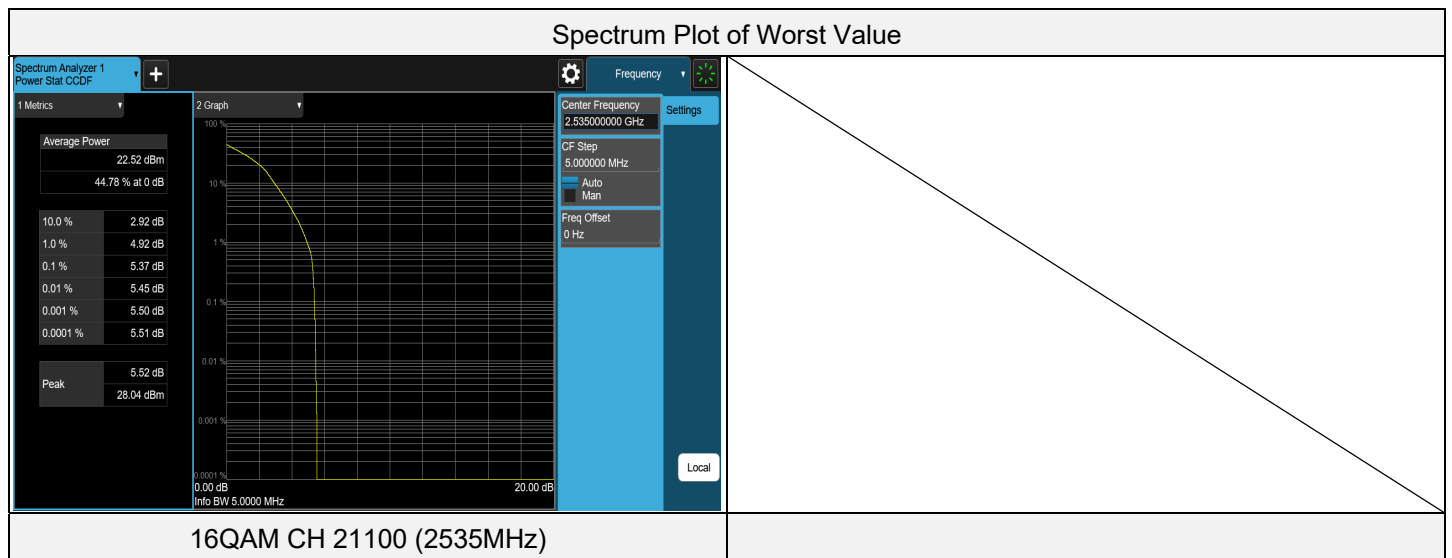

LTE Band 7, Channel Bandwidth: 10 MHz

Test Condition	Channel	Frequency (MHz)	Measure. Value(dB)	Limit dB	Result
QPSK	20800	2505	4.17	13	PASS
QPSK	21100	2535	4.30	13	PASS
QPSK	21400	2565	4.09	13	PASS
16QAM	20800	2505	5.19	13	PASS
16QAM	21100	2535	5.22	13	PASS
16QAM	21400	2565	5.10	13	PASS

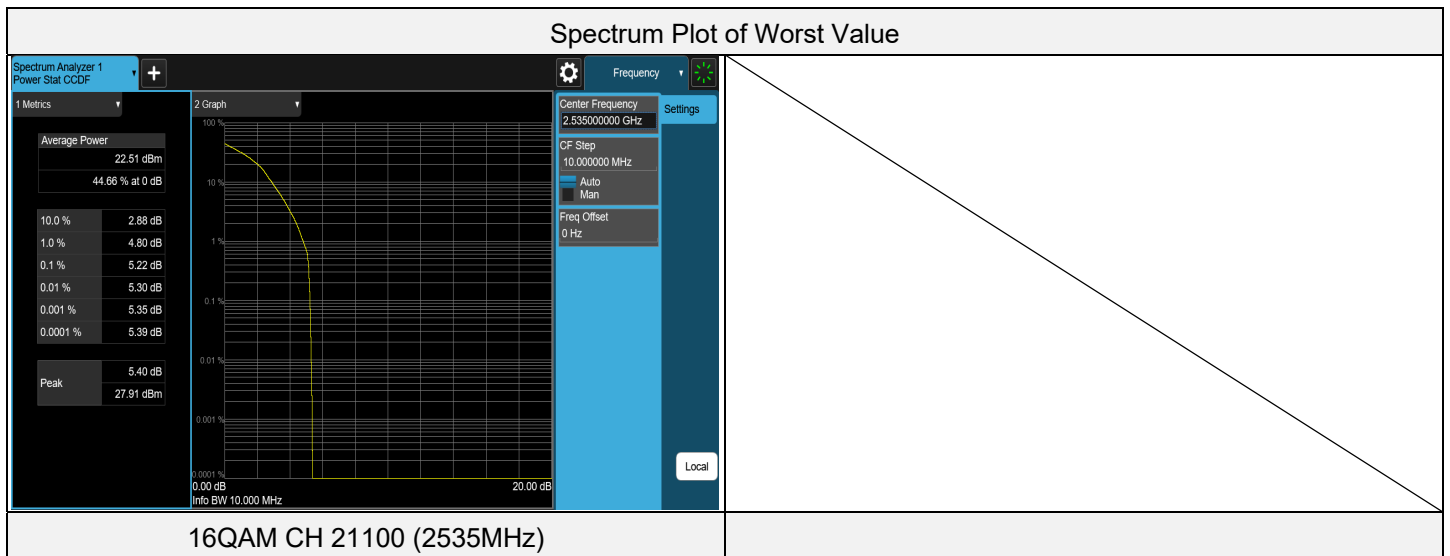

LTE Band 7, Channel Bandwidth: 20 MHz

Test Condition	Channel	Frequency (MHz)	Measure. Value(dB)	Limit dB	Result
QPSK	20850	2510	4.15	13	PASS
QPSK	21100	2535	4.09	13	PASS
QPSK	21350	2560	4.30	13	PASS
16QAM	20850	2510	5.11	13	PASS
16QAM	21100	2535	5.06	13	PASS
16QAM	21350	2560	5.30	13	PASS

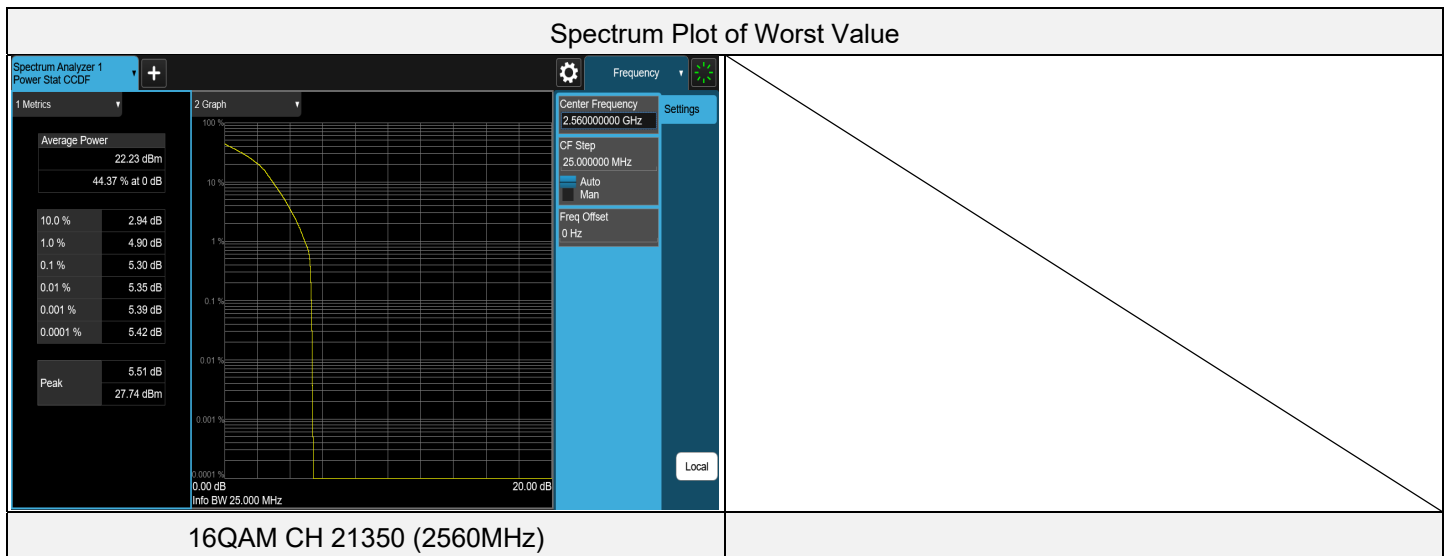

7.3.4 LTE Band 26 (Part 22)

LTE Band 26, Channel Bandwidth: 1.4 MHz

Test Condition	Channel	Frequency (MHz)	Measure. Value(dB)	Limit dB	Result
QPSK	26797	824.7	3.80	13	PASS
QPSK	26915	836.5	3.79	13	PASS
QPSK	27033	848.3	3.53	13	PASS
16QAM	26797	824.7	4.70	13	PASS
16QAM	26915	836.5	4.86	13	PASS
16QAM	27033	848.3	4.44	13	PASS

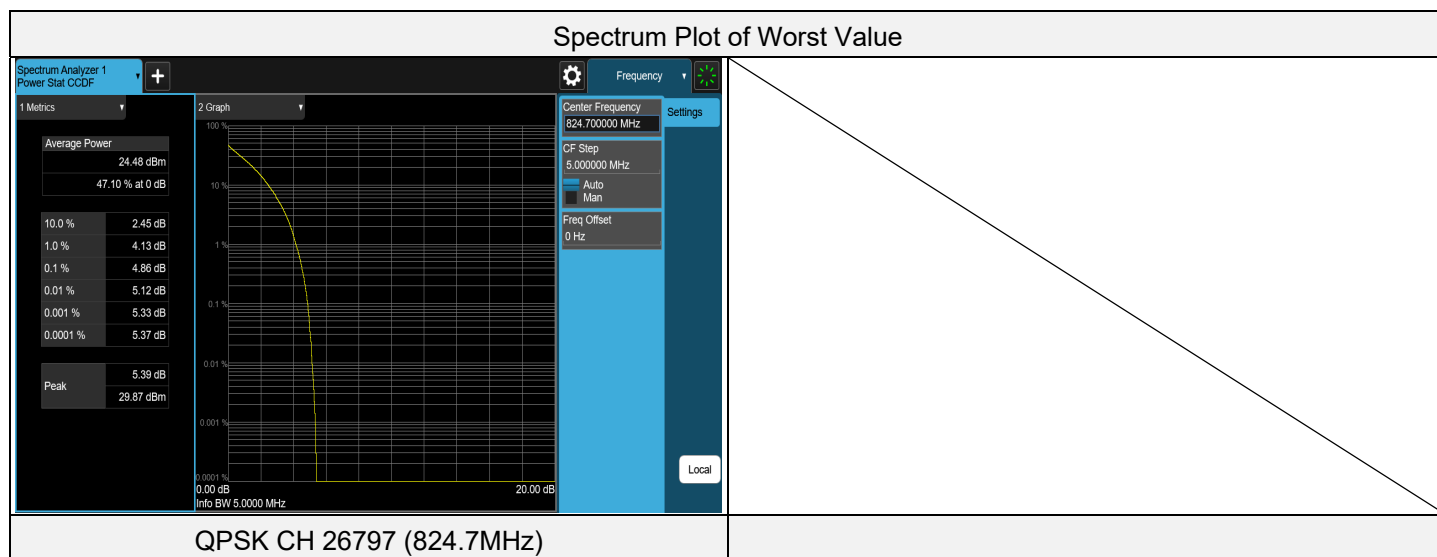

LTE Band 26, Channel Bandwidth: 3 MHz

Test Condition	Channel	Frequency (MHz)	Measure. Value(dB)	Limit dB	Result
QPSK	26805	825.5	3.80	13	PASS
QPSK	26915	836.5	3.97	13	PASS
QPSK	27025	847.5	3.60	13	PASS
16QAM	26805	825.5	4.69	13	PASS
16QAM	26915	836.5	4.87	13	PASS
16QAM	27025	847.5	4.50	13	PASS

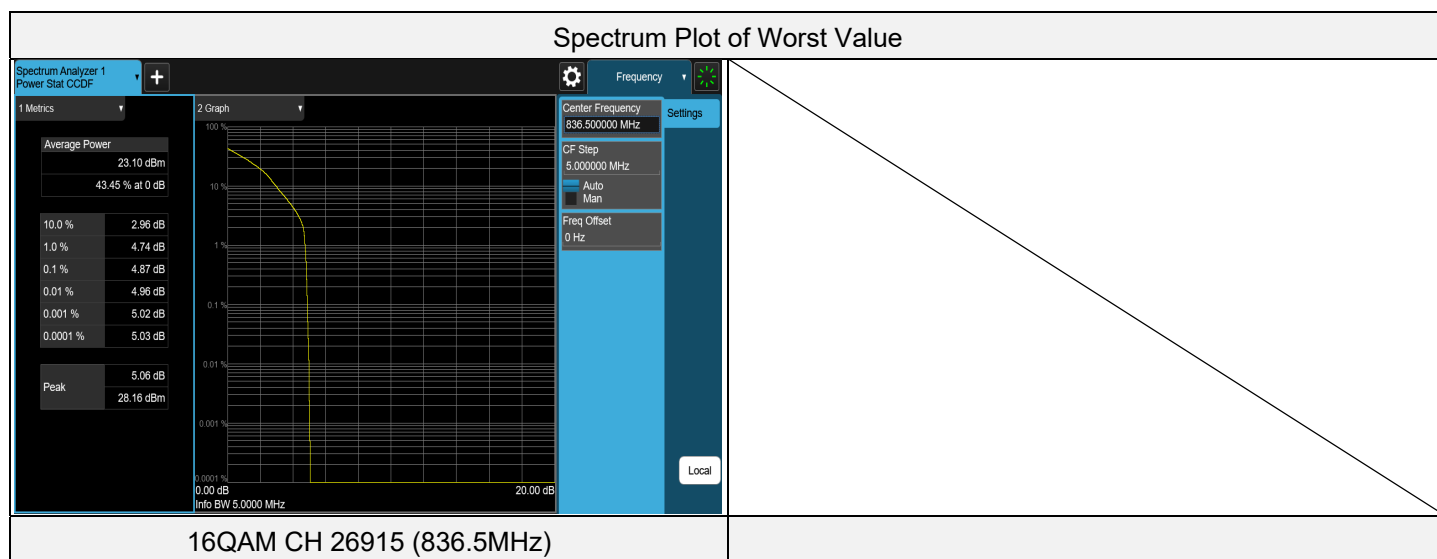



LTE Band 26, Channel Bandwidth: 5 MHz

Test Condition	Channel	Frequency (MHz)	Measure. Value(dB)	Limit dB	Result
QPSK	26815	826.5	3.71	13	PASS
QPSK	26915	836.5	3.85	13	PASS
QPSK	27015	846.5	3.67	13	PASS
16QAM	26815	826.5	4.60	13	PASS
16QAM	26915	836.5	4.75	13	PASS
16QAM	27015	846.5	4.59	13	PASS

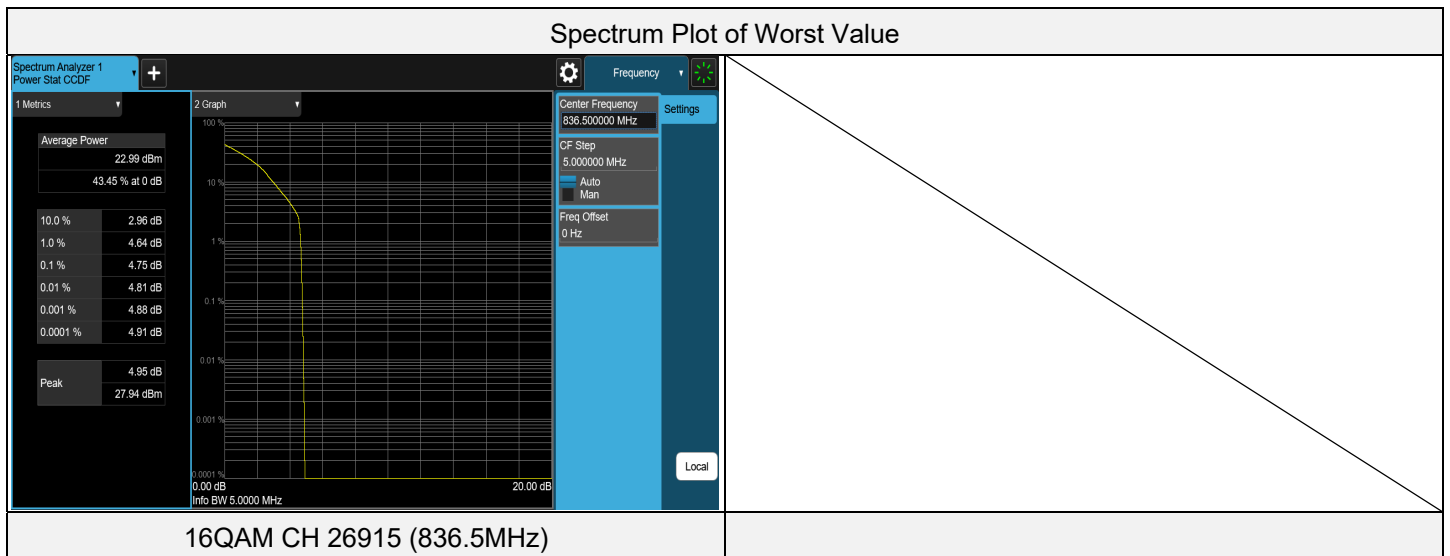



LTE Band 26, Channel Bandwidth: 15 MHz

Test Condition	Channel	Frequency (MHz)	Measure. Value(dB)	Limit dB	Result
QPSK	26865	831.5	3.67	13	PASS
QPSK	26915	836.5	3.75	13	PASS
QPSK	26965	841.5	3.78	13	PASS
16QAM	26865	831.5	4.51	13	PASS
16QAM	26915	836.5	4.62	13	PASS
16QAM	26965	841.5	4.69	13	PASS

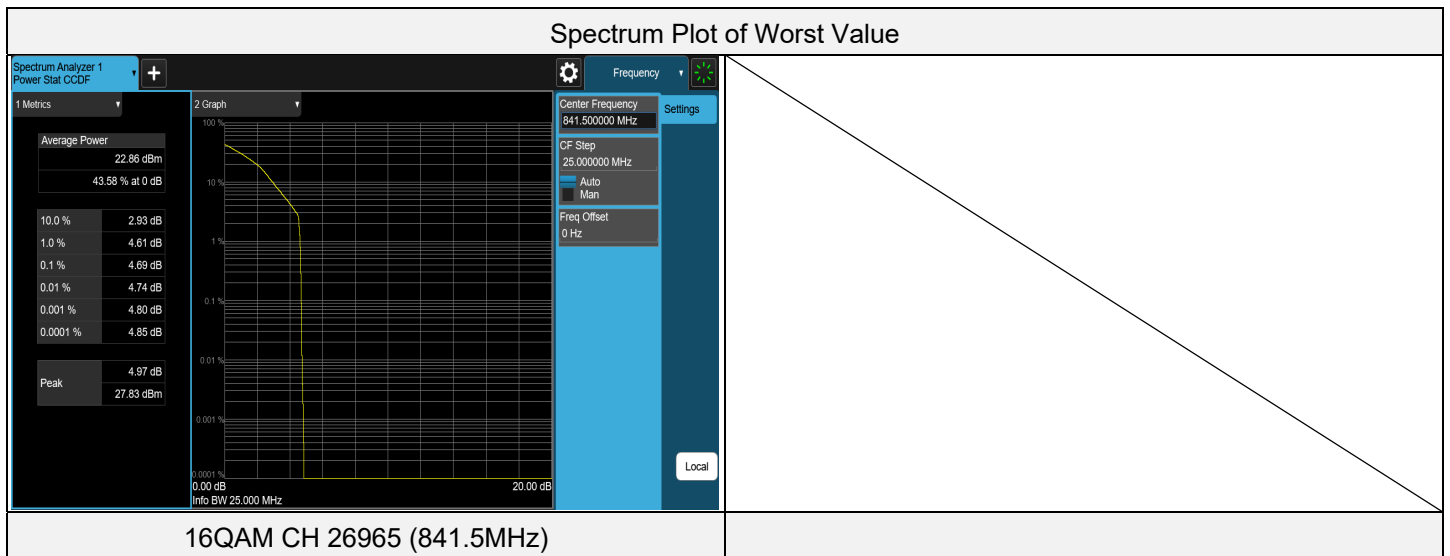

LTE Band 38, Channel Bandwidth: 10 MHz

Test Condition	Channel	Frequency (MHz)	Measure. Value(dB)	Limit dB	Result
QPSK	37800	2575	8.17	13	PASS
QPSK	38000	2595	7.80	13	PASS
QPSK	38200	2615	7.78	13	PASS
16QAM	37800	2575	9.12	13	PASS
16QAM	38000	2595	9.57	13	PASS
16QAM	38200	2615	8.98	13	PASS

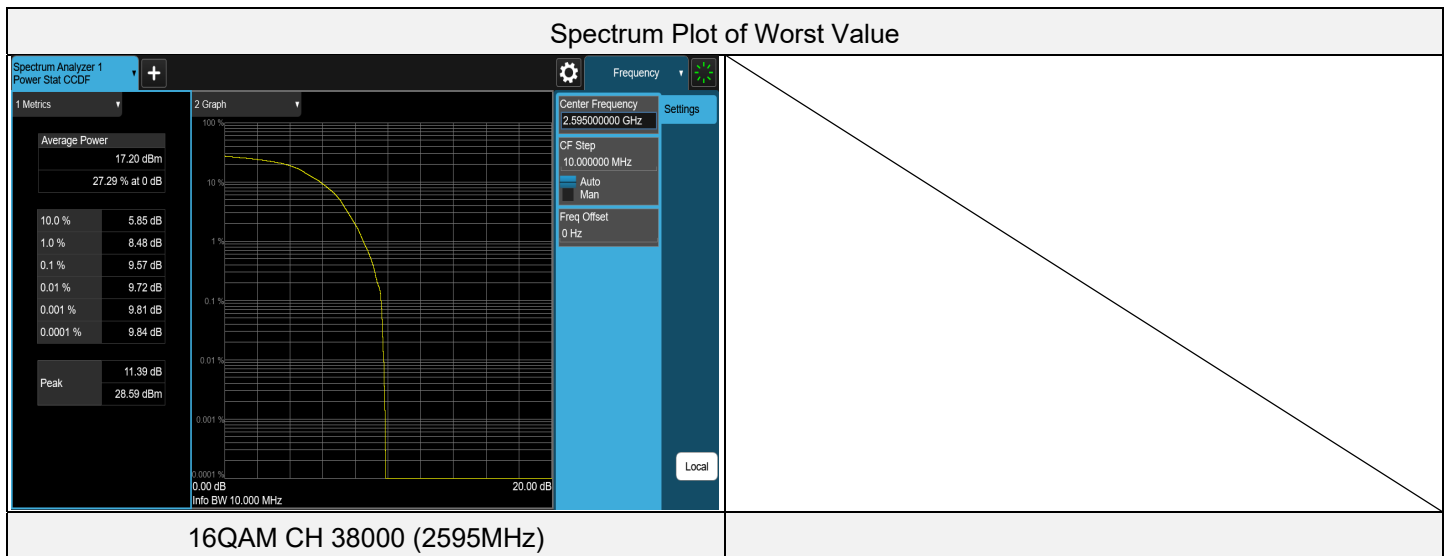



LTE Band 38, Channel Bandwidth: 15 MHz

Test Condition	Channel	Frequency (MHz)	Measure. Value(dB)	Limit dB	Result
QPSK	37825	2577.5	8.36	13	PASS
QPSK	38000	2595	7.93	13	PASS
QPSK	38175	2612.5	6.90	13	PASS
16QAM	37825	2577.5	8.88	13	PASS
16QAM	38000	2595	6.99	13	PASS
16QAM	38175	2612.5	9.25	13	PASS

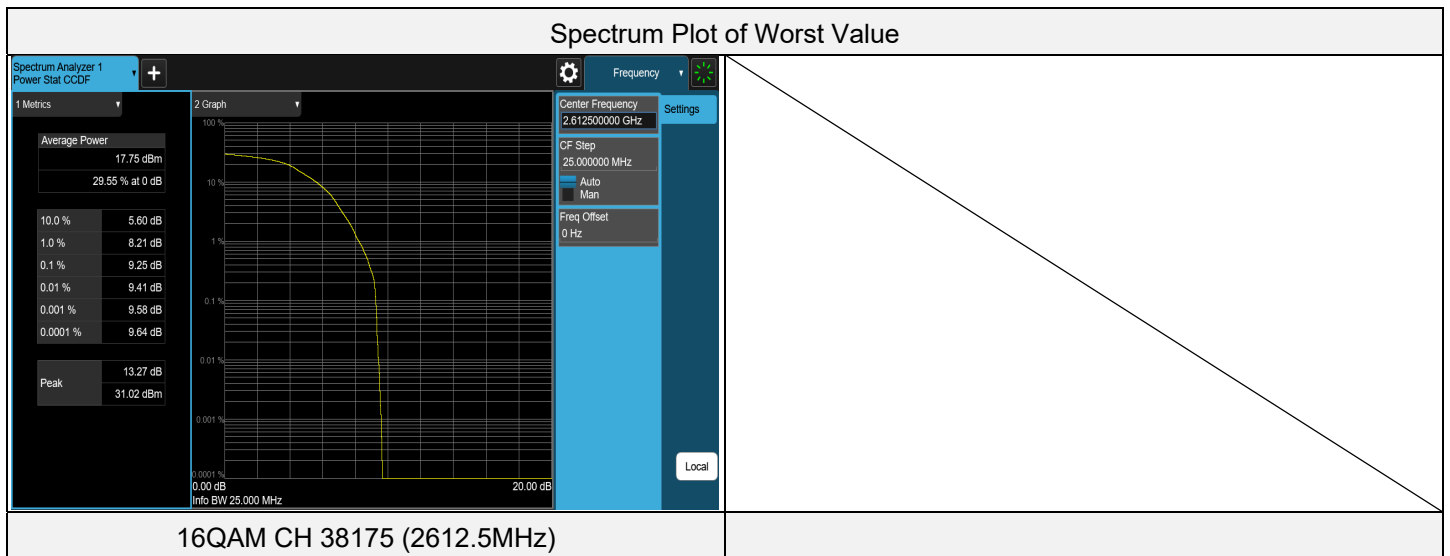



LTE Band 41, Channel Bandwidth: 15 MHz

Test Condition	Channel	Frequency (MHz)	Measure. Value(dB)	Limit dB	Result
QPSK	40315	2562.5	8.46	13	PASS
QPSK	40690	2600	6.62	13	PASS
QPSK	41165	2647.5	8.49	13	PASS
16QAM	40315	2562.5	8.90	13	PASS
16QAM	40690	2600	9.03	13	PASS
16QAM	41165	2647.5	10.40	13	PASS

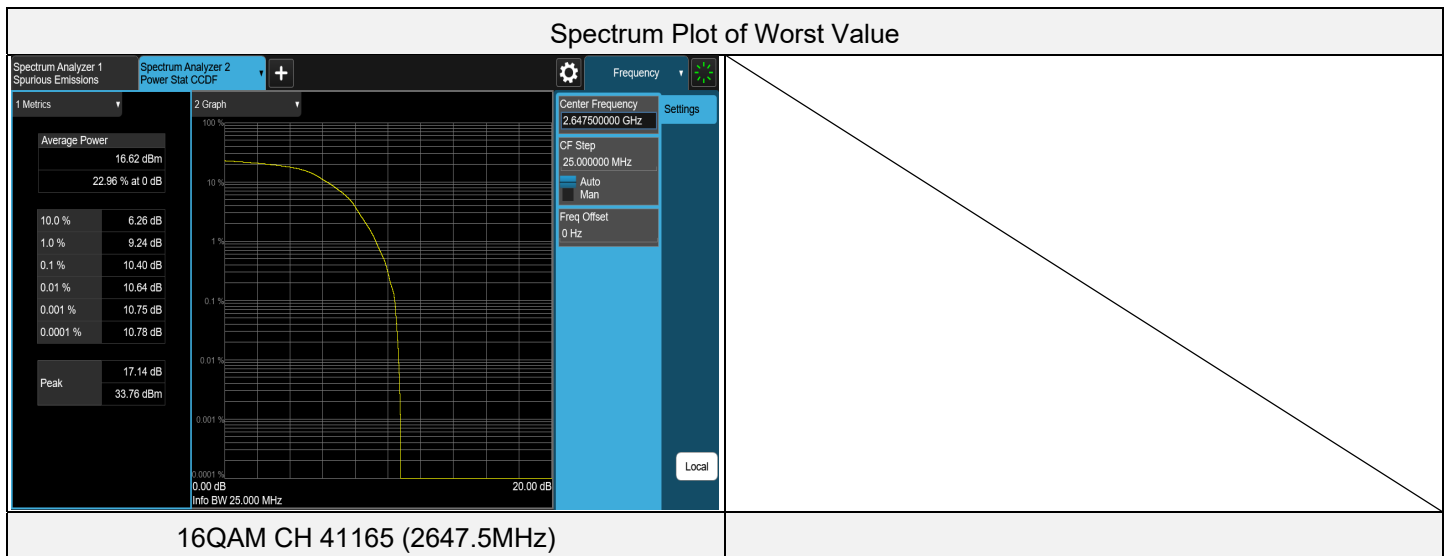

7.4 Bandwidth

Input Power:	3.8 Vdc	Environmental Conditions:	27°C, 68% RH	Tested By:	Noah Chang
--------------	---------	---------------------------	--------------	------------	------------

7.4.1 WCDMA Band 5

Modulation	Channel	Frequency (MHz)	Occupied Bandwidth (MHz)	26 dB Bandwidth (MHz)
WCDMA	4132	826.4	4.1252	4.663
WCDMA	4182	836.4	4.1257	4.663
WCDMA	4223	846.6	4.1260	4.682
HSDPA	4132	826.4	4.1342	4.702
HSDPA	4182	836.4	4.1387	4.704
HSDPA	4223	846.6	4.1233	4.681
HSUPA	4132	826.4	4.1374	4.686
HSUPA	4182	836.4	4.1406	4.688
HSUPA	4223	846.6	4.1266	4.694

Spectrum Plot of Worst Value

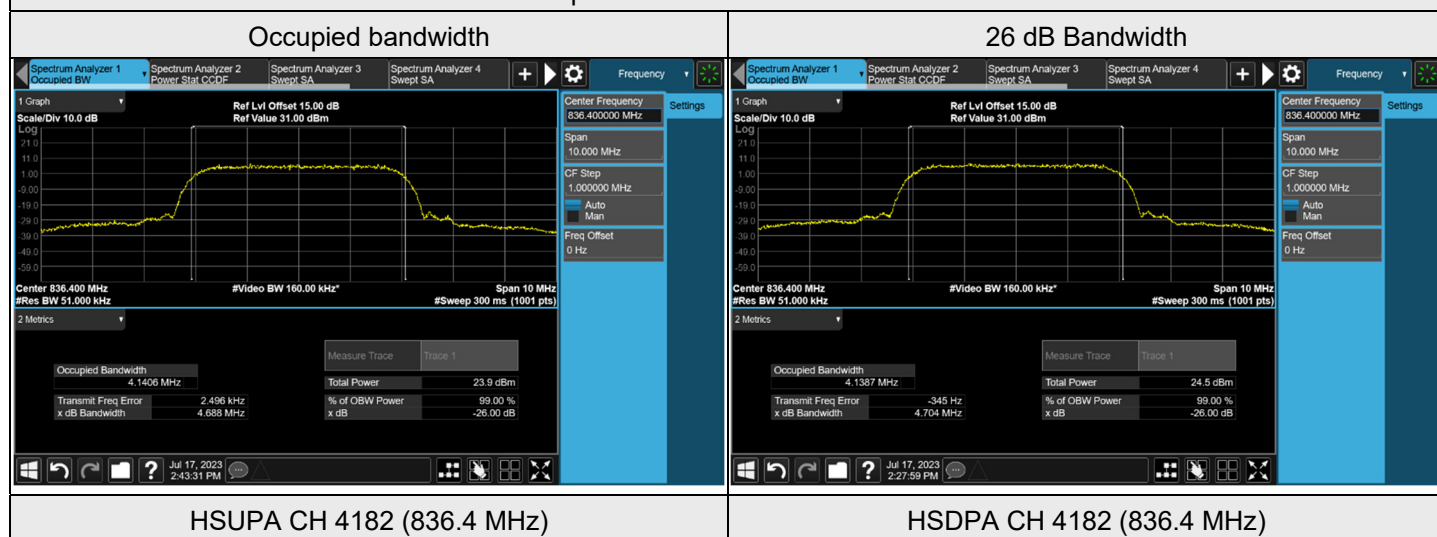

7.4.2 LTE Band 5

LTE Band 5, Channel Bandwidth: 1.4 MHz

Test Condition	Channel	Frequency (MHz)	Occupied bandwidth (MHz)	26 dB Bandwidth (MHz)
QPSK	20407	824.7	1.0888	1.264
QPSK	20525	836.5	1.0911	1.261
QPSK	20643	848.3	1.0919	1.268
16QAM	20407	824.7	1.0889	1.251
16QAM	20525	836.5	1.0886	1.245
16QAM	20643	848.3	1.0881	1.259

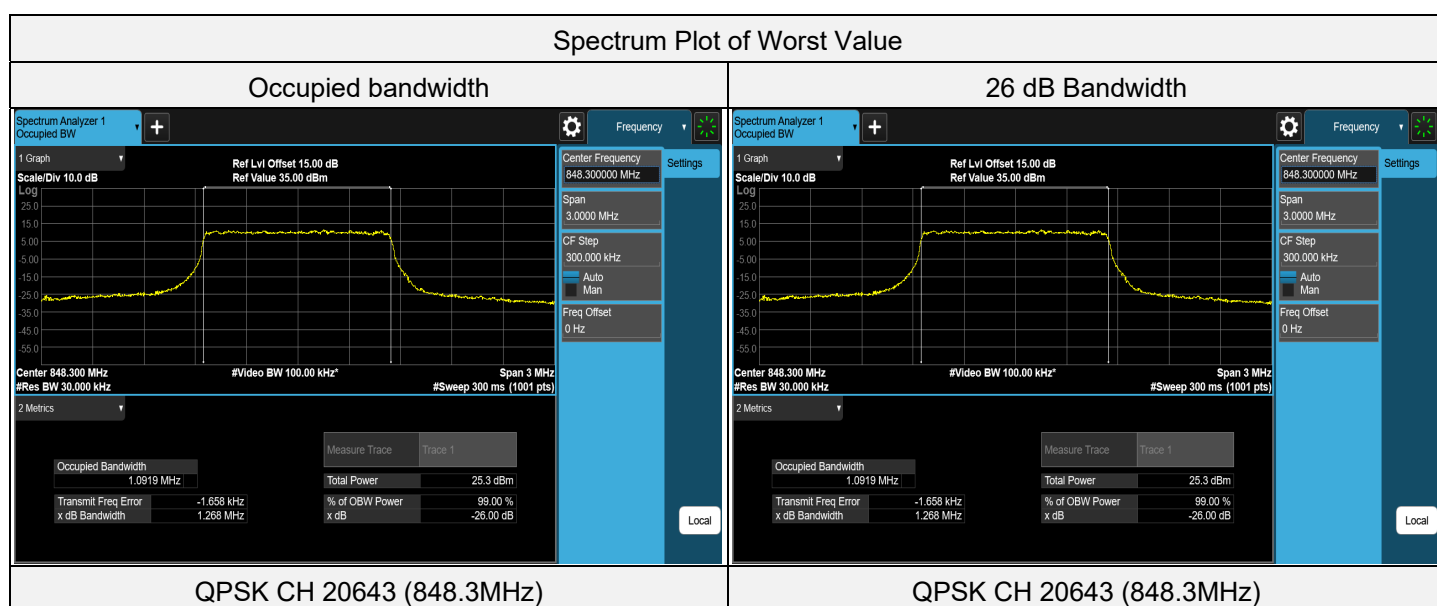

LTE Band 5, Channel Bandwidth: 3 MHz

Test Condition	Channel	Frequency (MHz)	Occupied bandwidth (MHz)	26 dB Bandwidth (MHz)
QPSK	20415	825.5	2.6961	2.902
QPSK	20525	836.5	2.6990	2.908
QPSK	20635	847.5	2.6933	2.903
16QAM	20415	825.5	2.7002	2.928
16QAM	20525	836.5	2.6982	2.923
16QAM	20635	847.5	2.6964	2.931

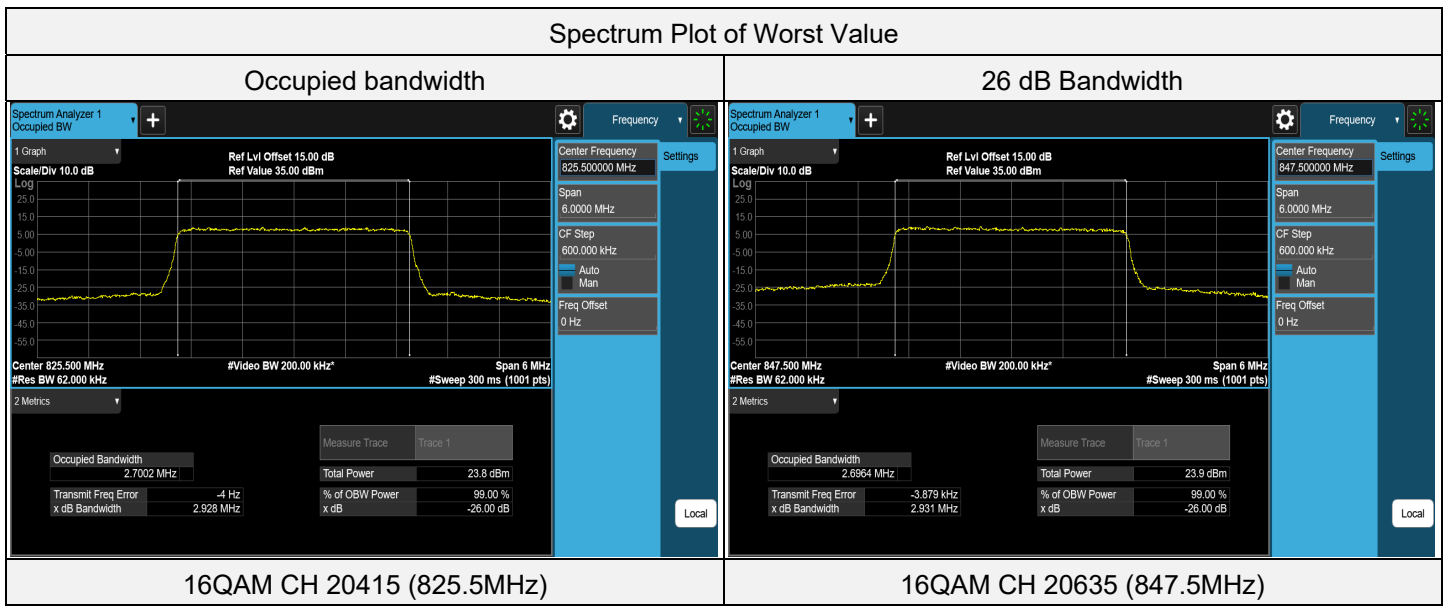

LTE Band 5, Channel Bandwidth: 5 MHz

Test Condition	Channel	Frequency (MHz)	Occupied bandwidth (MHz)	26 dB Bandwidth (MHz)
QPSK	20425	826.5	4.4910	4.831
QPSK	20525	836.5	4.4967	4.815
QPSK	20625	846.5	4.4902	4.815
16QAM	20425	826.5	4.4889	4.826
16QAM	20525	836.5	4.4907	4.812
16QAM	20625	846.5	4.4898	4.823

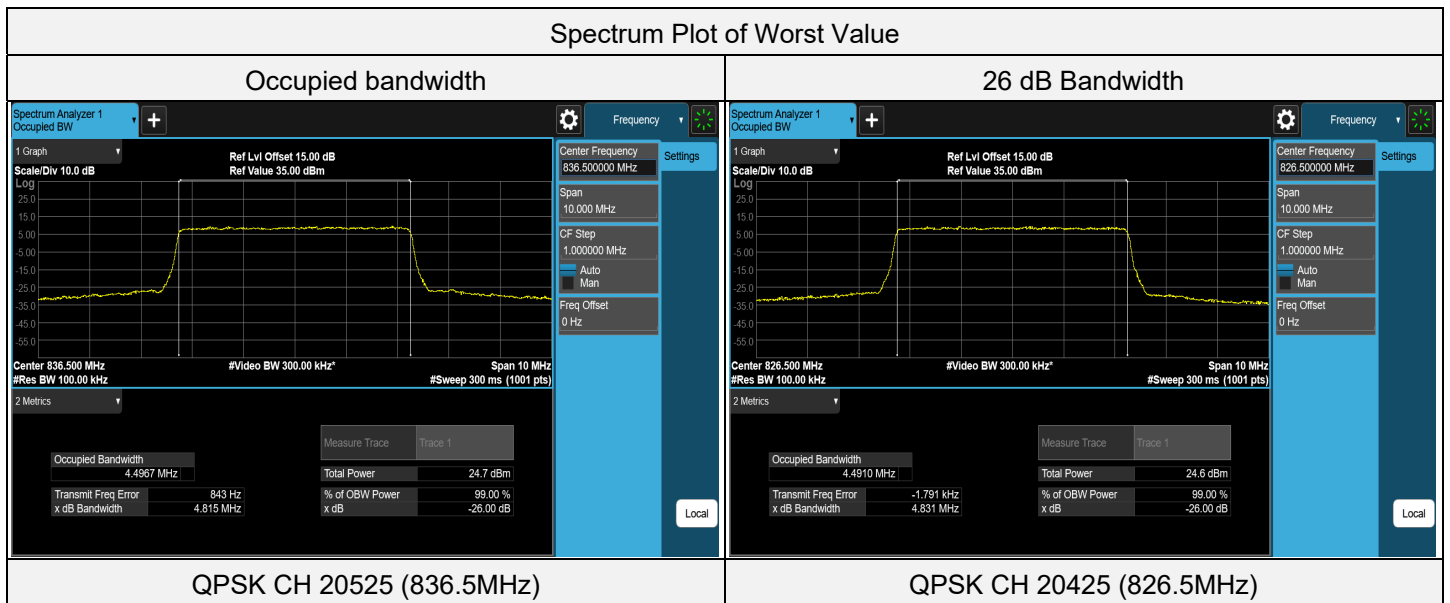

LTE Band 5, Channel Bandwidth: 10 MHz

Test Condition	Channel	Frequency (MHz)	Occupied bandwidth (MHz)	26 dB Bandwidth (MHz)
QPSK	20450	829	8.9596	9.509
QPSK	20525	836.5	8.9627	9.500
QPSK	20600	844	8.9452	9.503
16QAM	20450	829	8.9653	9.511
16QAM	20525	836.5	8.9649	9.521
16QAM	20600	844	8.9448	9.502

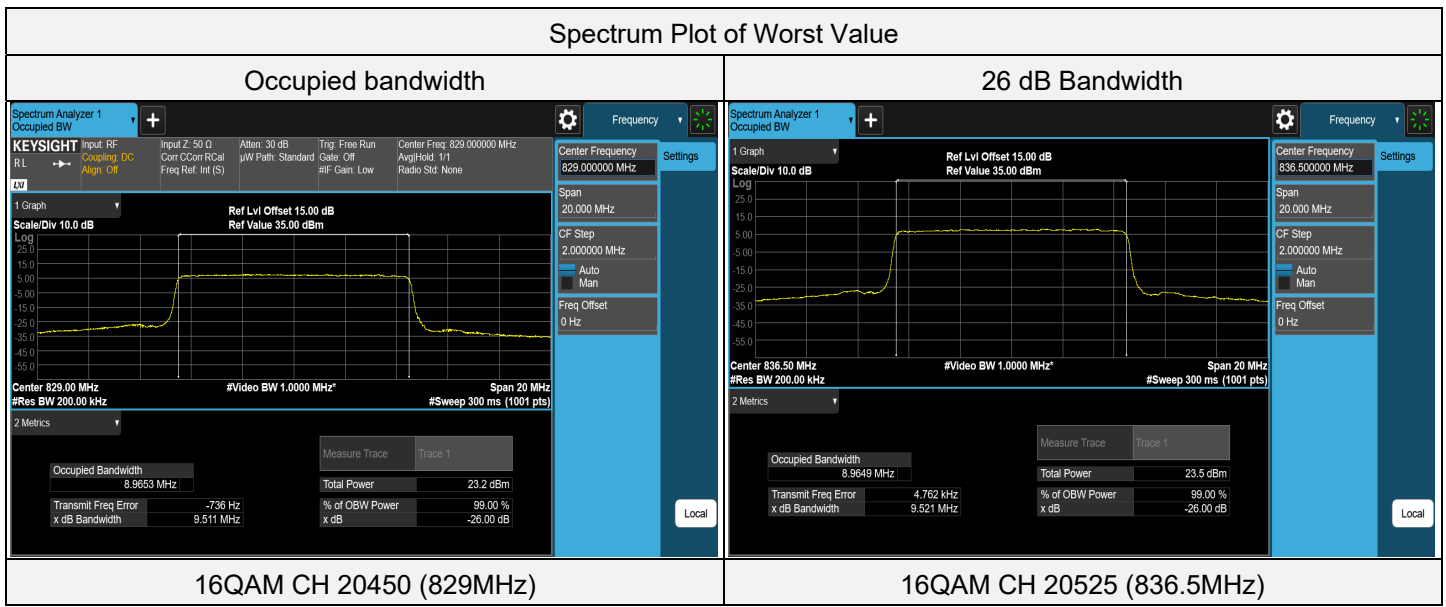

7.4.3 LTE Band 7

LTE Band 7, Channel Bandwidth: 5 MHz

Test Condition	Channel	Frequency (MHz)	Occupied bandwidth (MHz)	26 dB Bandwidth (MHz)
QPSK	20775	2502.5	4.4959	4.822
QPSK	21100	2535	4.4917	4.823
QPSK	21425	2567.5	4.4951	4.821
16QAM	20775	2502.5	4.4900	4.819
16QAM	21100	2535	4.4935	4.829
16QAM	21425	2567.5	4.4855	4.804

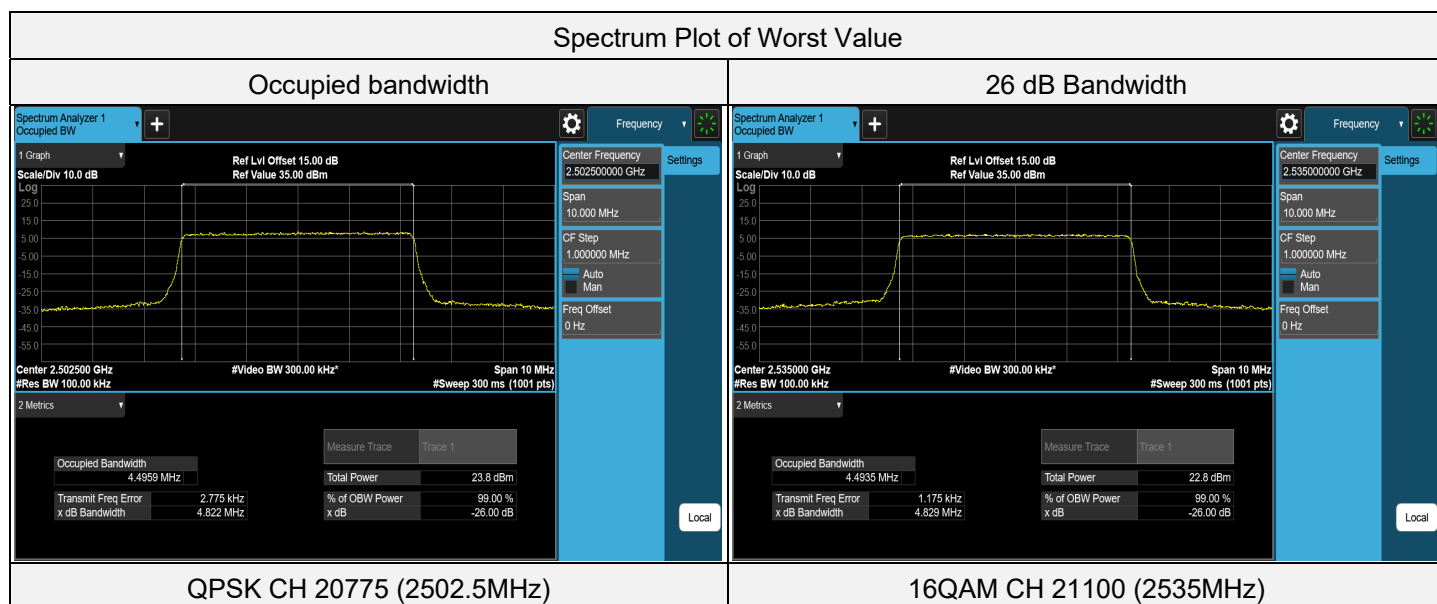

LTE Band 7, Channel Bandwidth: 10 MHz

Test Condition	Channel	Frequency (MHz)	Occupied bandwidth (MHz)	26 dB Bandwidth (MHz)
QPSK	20800	2505	8.9492	9.494
QPSK	21100	2535	8.9569	9.512
QPSK	21400	2565	8.9485	9.506
16QAM	20800	2505	8.9442	9.511
16QAM	21100	2535	8.9518	9.507
16QAM	21400	2565	8.9414	9.496

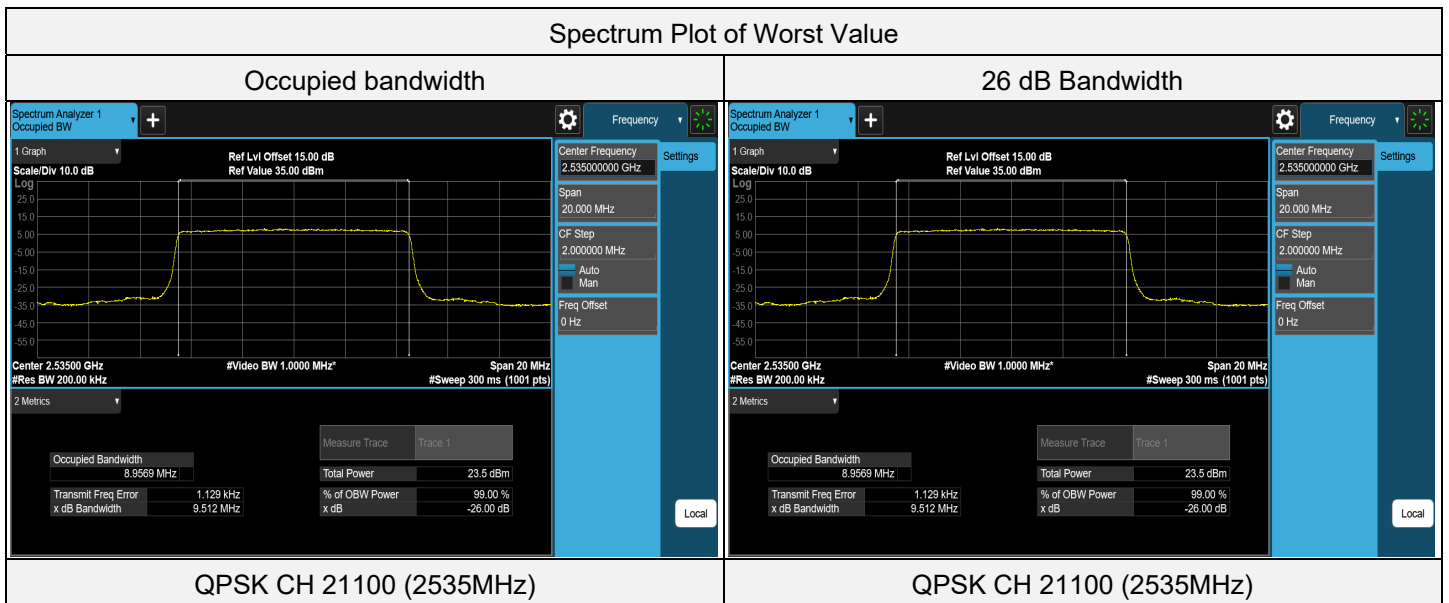

LTE Band 7, Channel Bandwidth: 15 MHz

Test Condition	Channel	Frequency (MHz)	Occupied bandwidth (MHz)	26 dB Bandwidth (MHz)
QPSK	20825	2507.5	13.4150	14.222
QPSK	21100	2535	13.4451	14.235
QPSK	21375	2562.5	13.4221	14.208
16QAM	20825	2507.5	13.4034	14.227
16QAM	21100	2535	13.4310	14.233
16QAM	21375	2562.5	13.4058	14.218

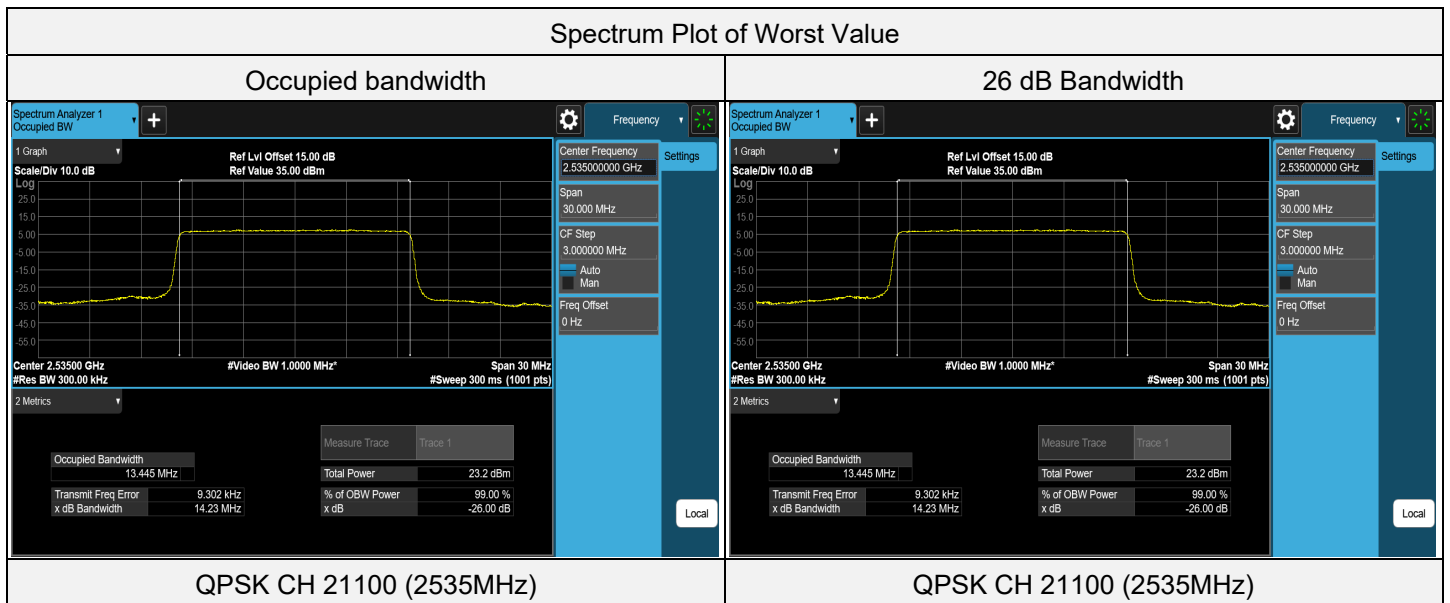

LTE Band 7, Channel Bandwidth: 20 MHz

Test Condition	Channel	Frequency (MHz)	Occupied bandwidth (MHz)	26 dB Bandwidth (MHz)
QPSK	20850	2510	17.8575	19.001
QPSK	21100	2535	17.9071	19.025
QPSK	21350	2560	17.8551	18.989
16QAM	20850	2510	17.8727	18.998
16QAM	21100	2535	17.9257	19.028
16QAM	21350	2560	17.8662	18.995

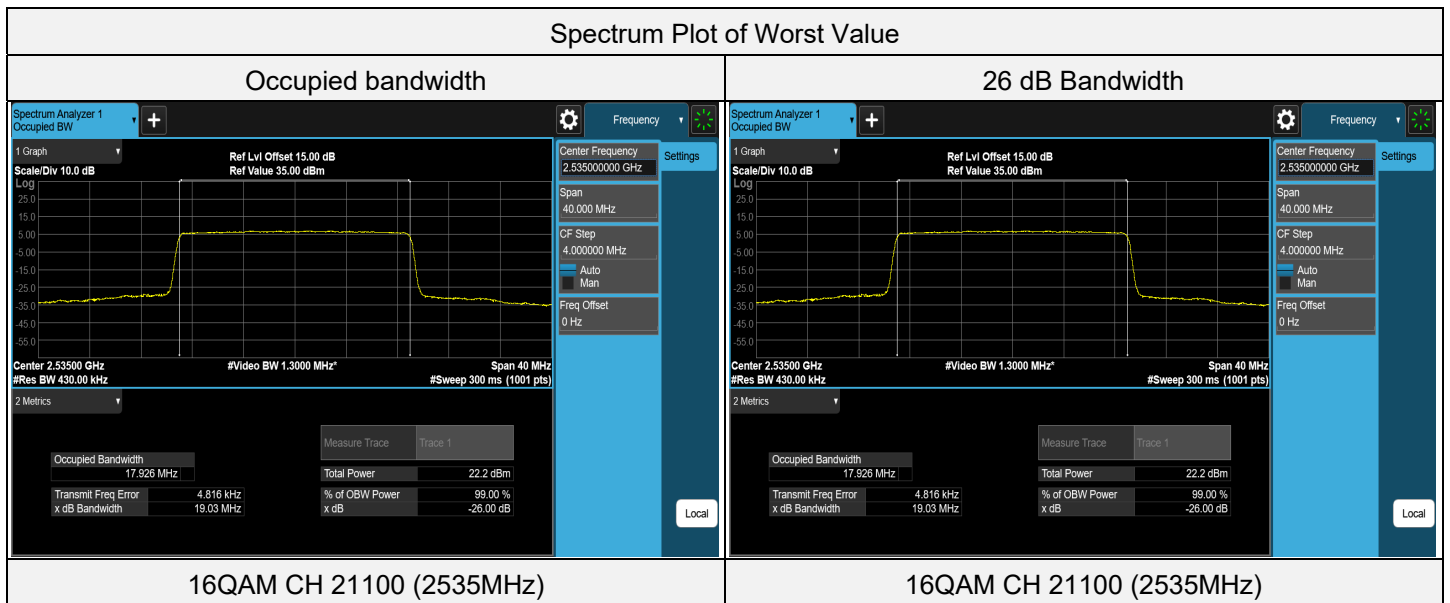

7.4.4 LTE Band 26 (Part 22)

LTE Band 26, Channel Bandwidth: 1.4 MHz

Test Condition	Channel	Frequency (MHz)	Occupied bandwidth (MHz)	26 dB Bandwidth (MHz)
QPSK	26797	824.7	1.0873	1.252
QPSK	26915	836.5	1.0914	1.256
QPSK	27033	848.3	1.0919	1.273
16QAM	26797	824.7	1.0893	1.251
16QAM	26915	836.5	1.0886	1.245
16QAM	27033	848.3	1.0896	1.258

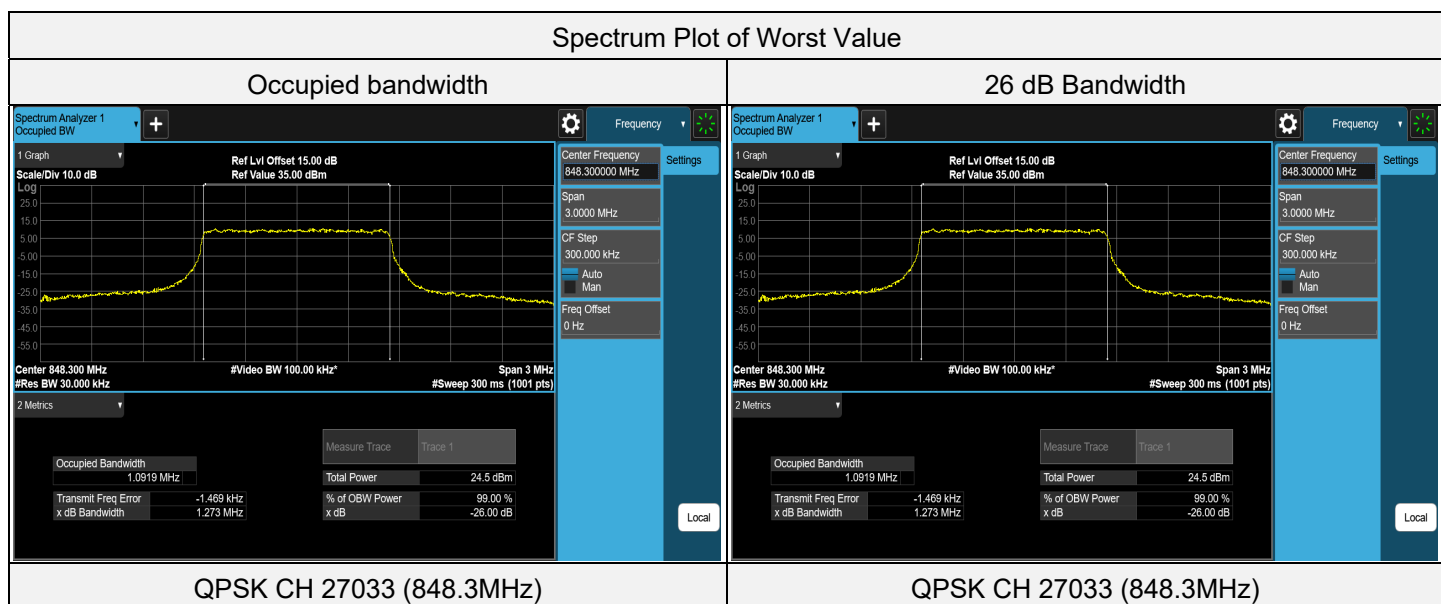

LTE Band 26, Channel Bandwidth: 3 MHz

Test Condition	Channel	Frequency (MHz)	Occupied bandwidth (MHz)	26 dB Bandwidth (MHz)
QPSK	26805	825.5	2.6957	2.908
QPSK	26915	836.5	2.6957	2.912
QPSK	27025	847.5	2.6968	2.925
16QAM	26805	825.5	2.6987	2.936
16QAM	26915	836.5	2.6923	2.910
16QAM	27025	847.5	2.6964	2.922

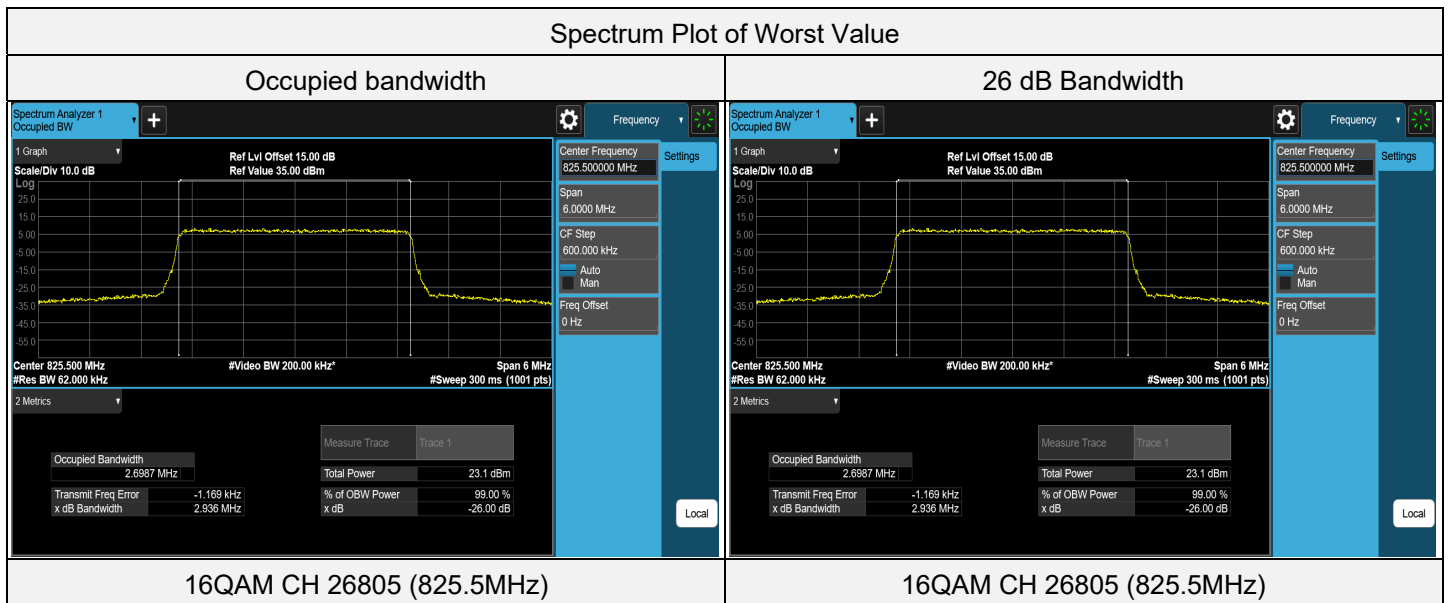

LTE Band 26, Channel Bandwidth: 5 MHz

Test Condition	Channel	Frequency (MHz)	Occupied bandwidth (MHz)	26 dB Bandwidth (MHz)
QPSK	26815	826.5	4.4917	4.812
QPSK	26915	836.5	4.4955	4.823
QPSK	27015	846.5	4.4890	4.835
16QAM	26815	826.5	4.4885	4.815
16QAM	26915	836.5	4.4891	4.828
16QAM	27015	846.5	4.4873	4.843

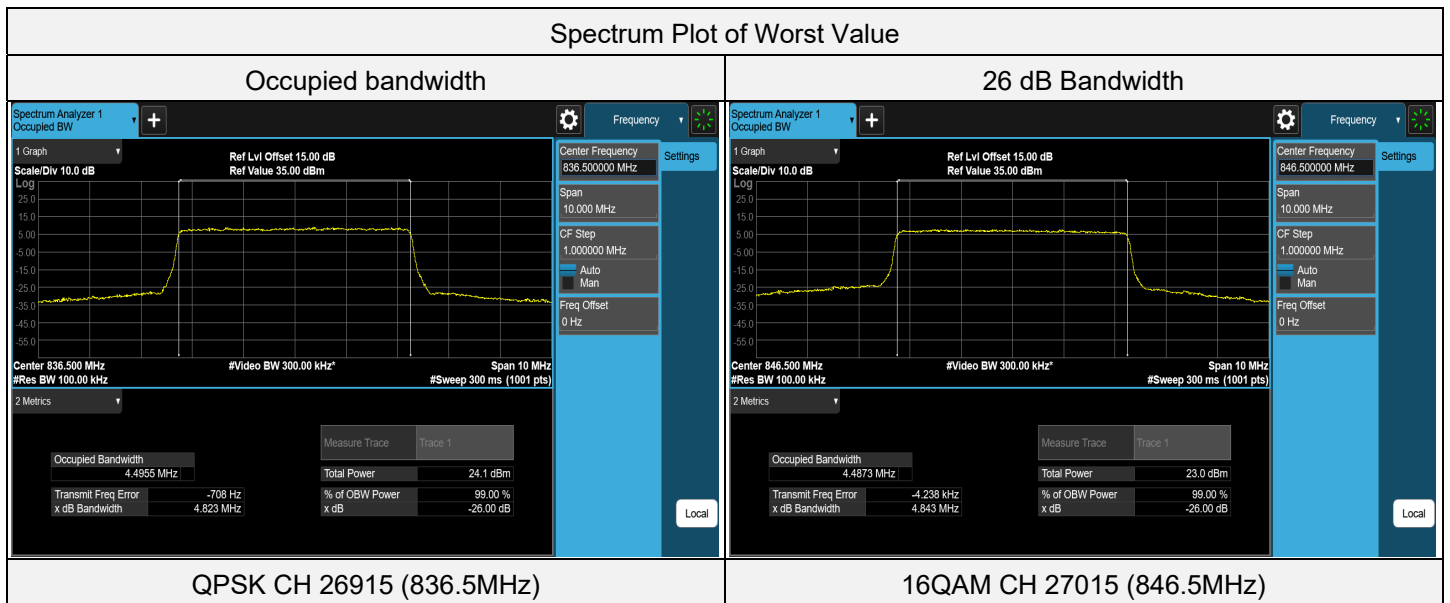

LTE Band 26, Channel Bandwidth: 10 MHz

Test Condition	Channel	Frequency (MHz)	Occupied bandwidth (MHz)	26 dB Bandwidth (MHz)
QPSK	26840	829	8.9546	9.523
QPSK	26915	836.5	8.9612	9.517
QPSK	26990	844	8.9459	9.513
16QAM	26840	829	8.9552	9.520
16QAM	26915	836.5	8.9623	9.516
16QAM	26990	844	8.9484	9.525

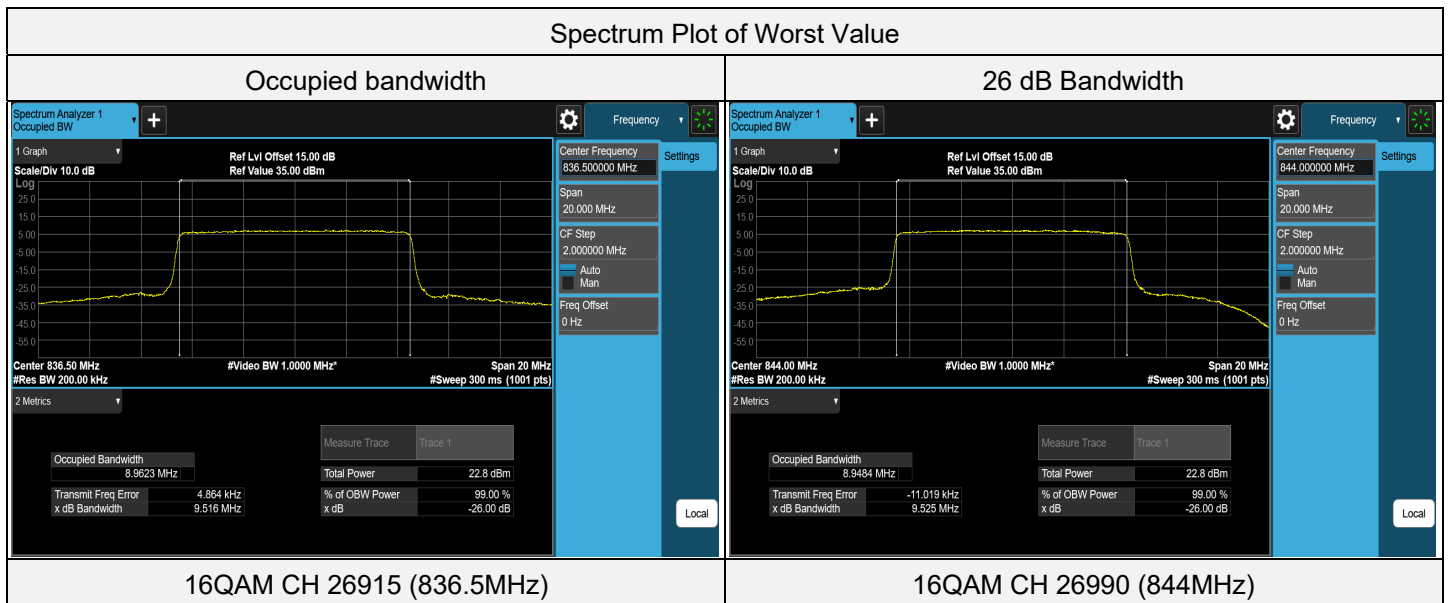

LTE Band 26, Channel Bandwidth: 15 MHz

Test Condition	Channel	Frequency (MHz)	Occupied bandwidth (MHz)	26 dB Bandwidth (MHz)
QPSK	26865	831.5	13.4485	14.233
QPSK	26915	836.5	13.4384	14.235
QPSK	26965	841.5	13.4268	14.224
16QAM	26865	831.5	13.4398	14.234
16QAM	26915	836.5	13.4308	14.244
16QAM	26965	841.5	13.4061	14.220

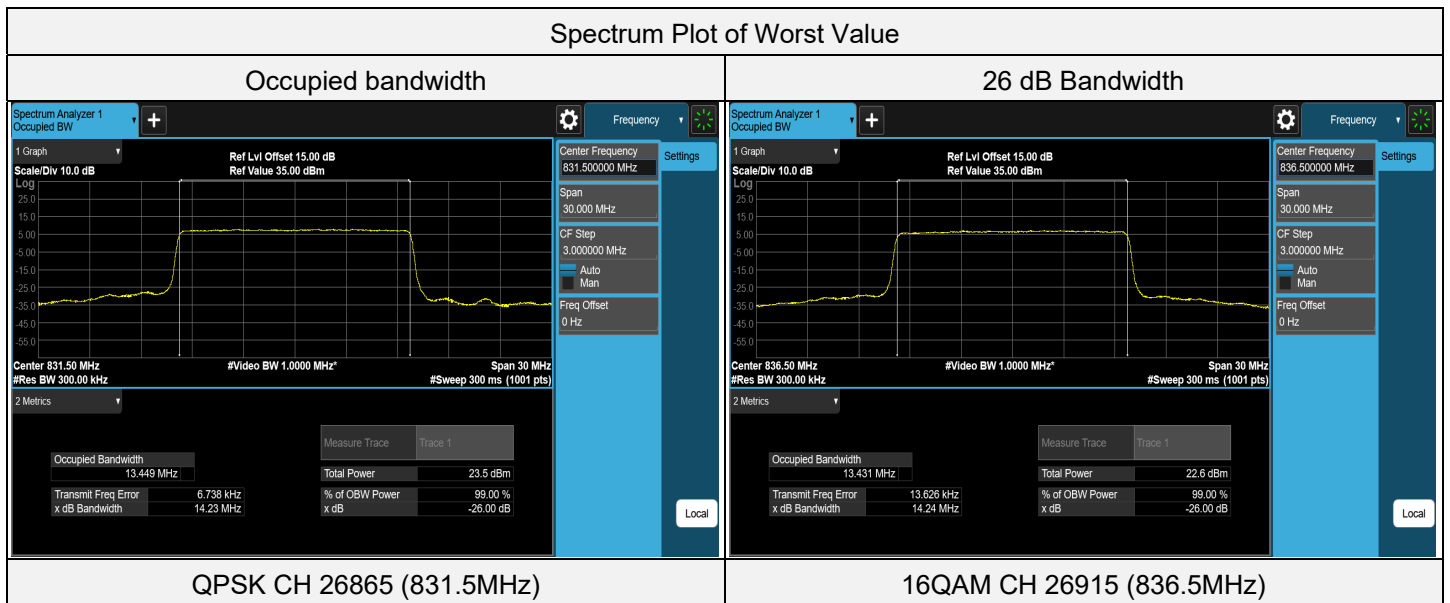

7.4.5 LTE Band 26 (Part 90)

LTE Band 26, Channel Bandwidth: 1.4 MHz

Test Condition	Channel	Frequency (MHz)	Occupied bandwidth (MHz)	26 dB Bandwidth (MHz)
QPSK	26697	814.7	1.0910	1.262
QPSK	26740	819	1.0914	1.267
QPSK	26783	823.3	1.0917	1.262
16QAM	26697	814.7	1.0891	1.247
16QAM	26740	819	1.0867	1.242
16QAM	26783	823.3	1.0893	1.252

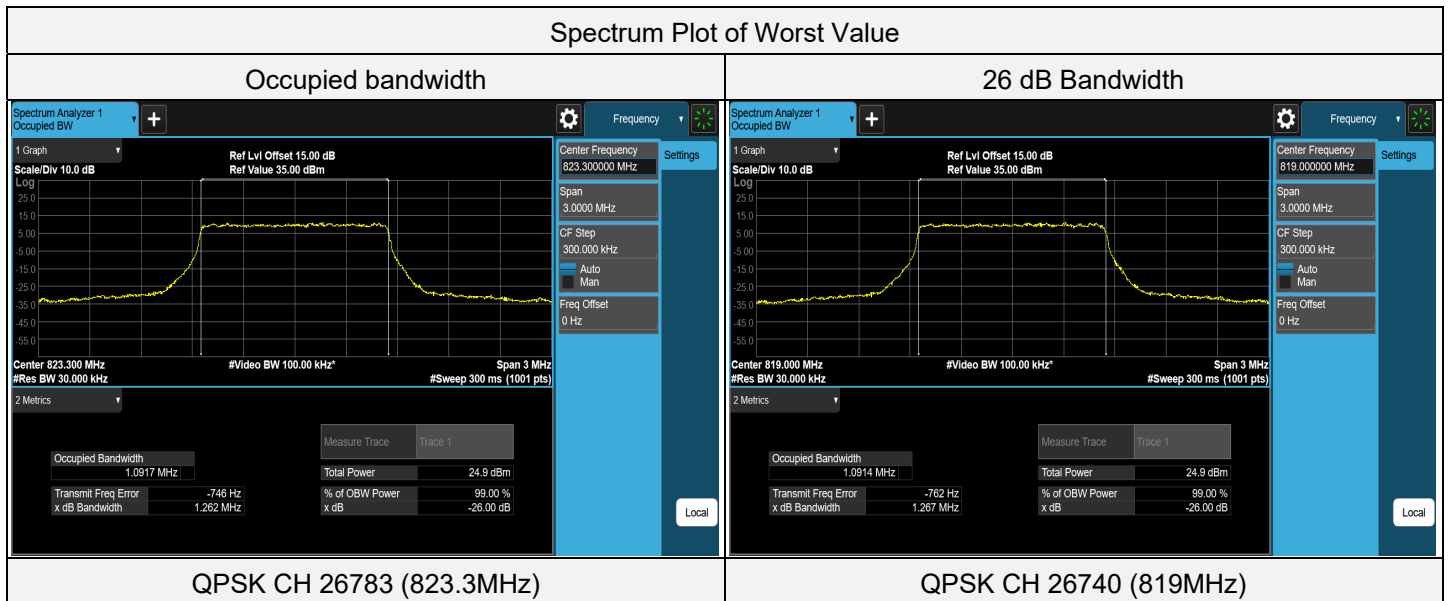

LTE Band 26, Channel Bandwidth: 3 MHz

Test Condition	Channel	Frequency (MHz)	Occupied bandwidth (MHz)	26 dB Bandwidth (MHz)
QPSK	26705	815.5	2.6947	2.915
QPSK	26740	819	2.6945	2.909
QPSK	26775	822.5	2.6963	2.925
16QAM	26705	815.5	2.6942	2.926
16QAM	26740	819	2.6954	2.931
16QAM	26775	822.5	2.6947	2.933

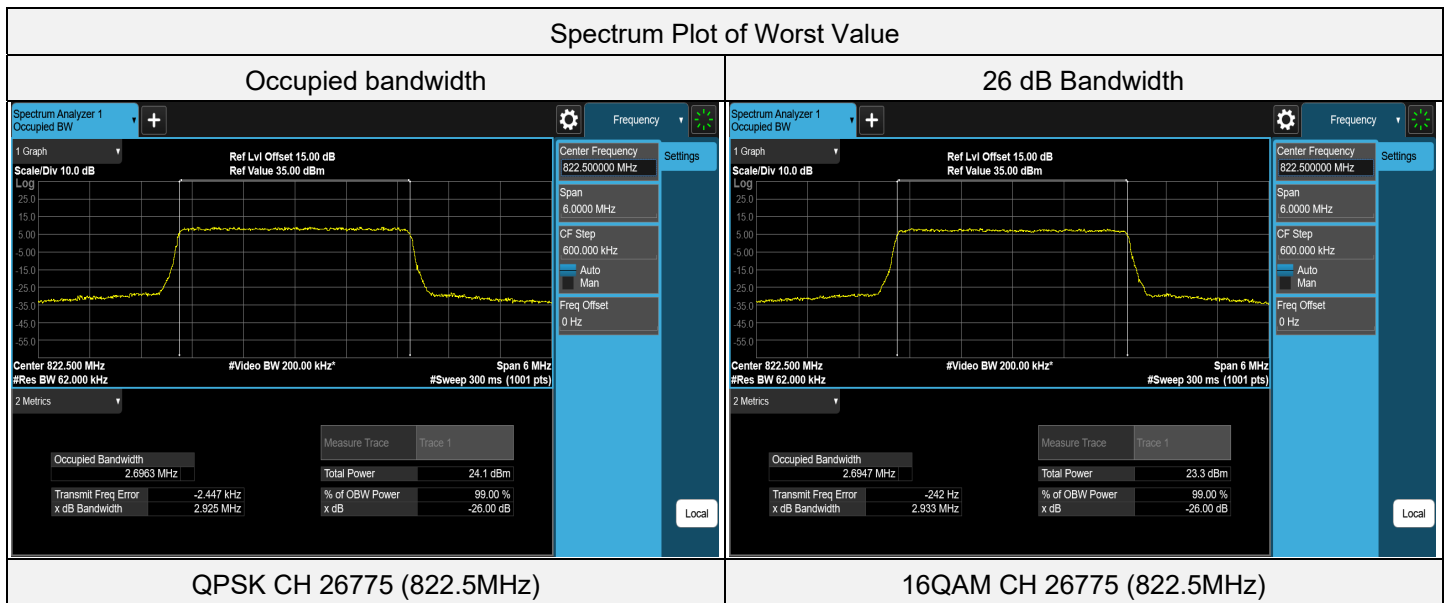

LTE Band 26, Channel Bandwidth: 5 MHz

Test Condition	Channel	Frequency (MHz)	Occupied bandwidth (MHz)	26 dB Bandwidth (MHz)
QPSK	26715	816.5	4.4982	4.817
QPSK	26740	819	4.4927	4.846
QPSK	26765	821.5	4.4931	4.836
16QAM	26715	816.5	4.4902	4.823
16QAM	26740	819	4.4878	4.835
16QAM	26765	821.5	4.4898	4.811

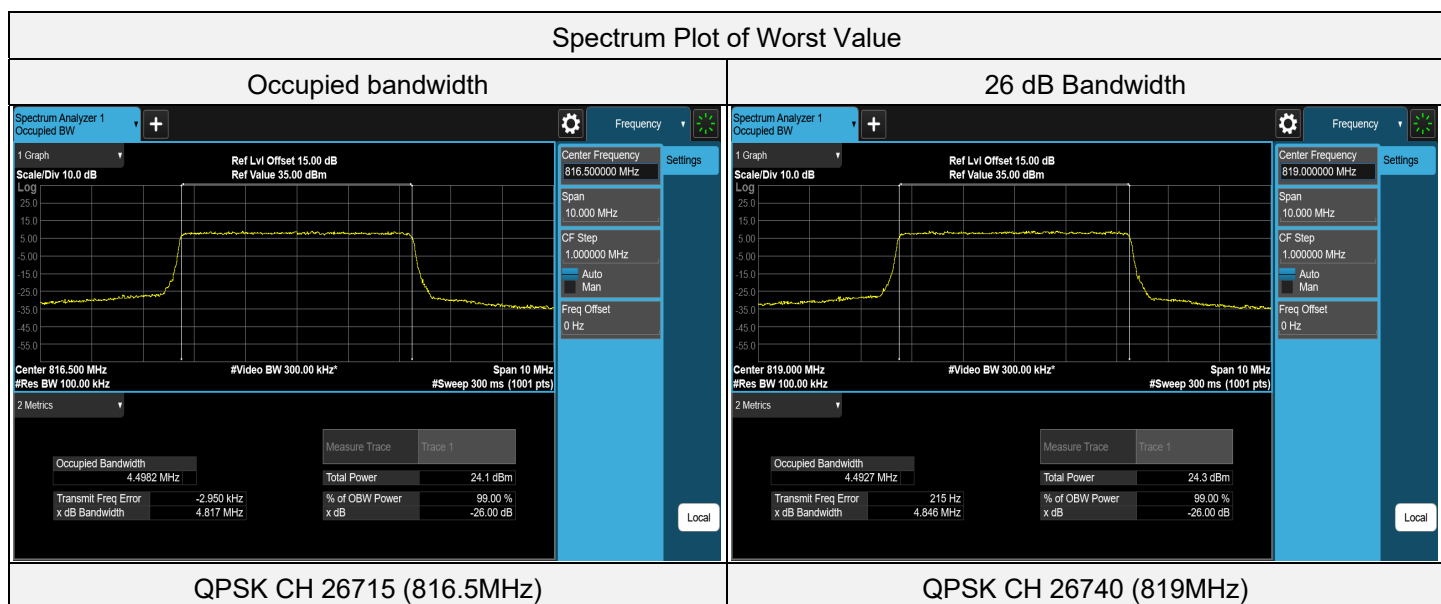



LTE Band 26, Channel Bandwidth: 10 MHz

Test Condition	Channel	Frequency (MHz)	Occupied bandwidth (MHz)	26 dB Bandwidth (MHz)
QPSK	26740	819	8.9619	9.521
16QAM	26740	819	8.9598	9.528

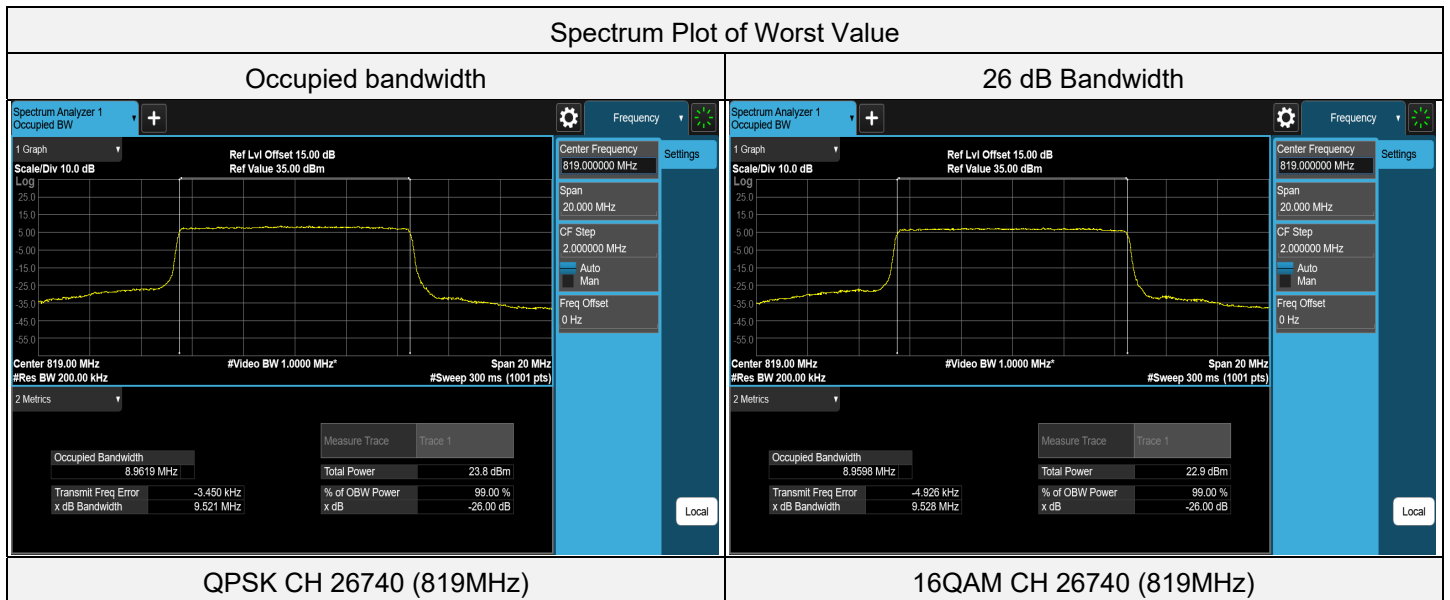

7.4.6 LTE Band 38

LTE Band 38, Channel Bandwidth: 5 MHz

Test Condition	Channel	Frequency (MHz)	Occupied bandwidth (MHz)	26 dB Bandwidth (MHz)
QPSK	37775	2572.5	4.4869	4.832
QPSK	38000	2595	4.4959	4.887
QPSK	38225	2617.5	4.4964	4.828
16QAM	37775	2572.5	4.4873	4.811
16QAM	38000	2595	4.4861	4.789
16QAM	38225	2617.5	4.4867	4.796

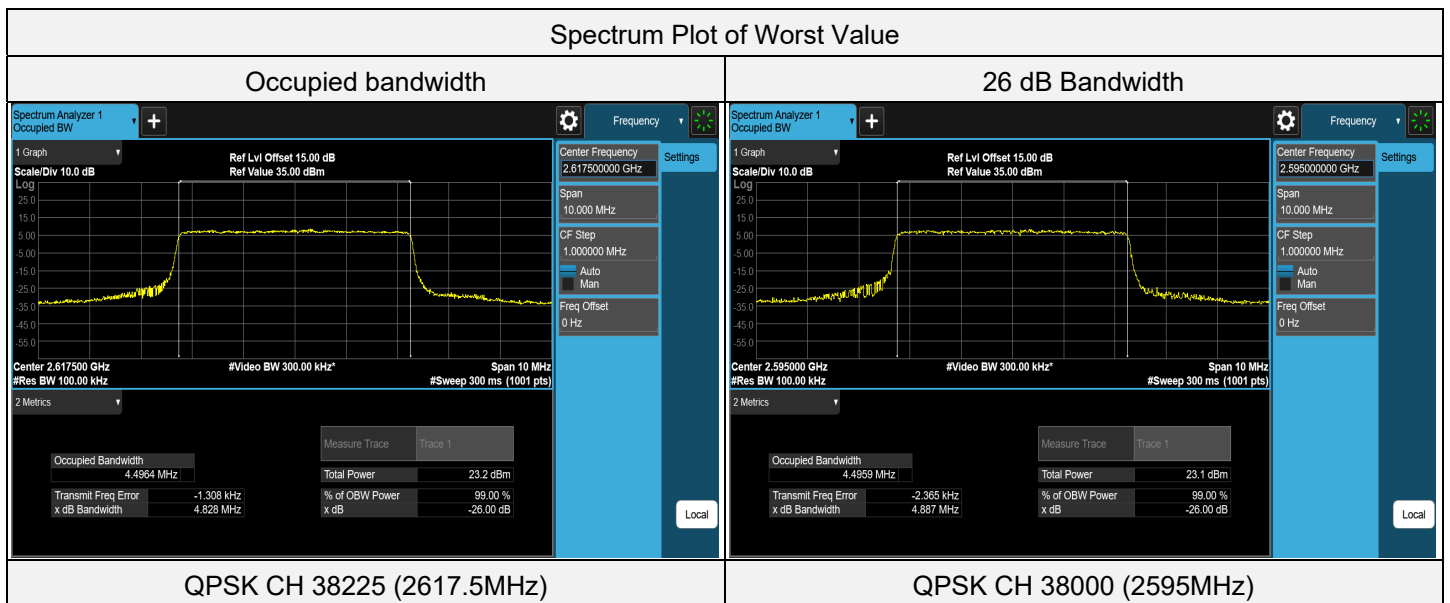



LTE Band 38, Channel Bandwidth: 10 MHz

Test Condition	Channel	Frequency (MHz)	Occupied bandwidth (MHz)	26 dB Bandwidth (MHz)
QPSK	37800	2575	8.9471	9.501
QPSK	38000	2595	8.9465	9.482
QPSK	38200	2615	8.9529	9.496
16QAM	37800	2575	8.9513	9.502
16QAM	38000	2595	8.9507	9.496
16QAM	38200	2615	8.9497	9.512

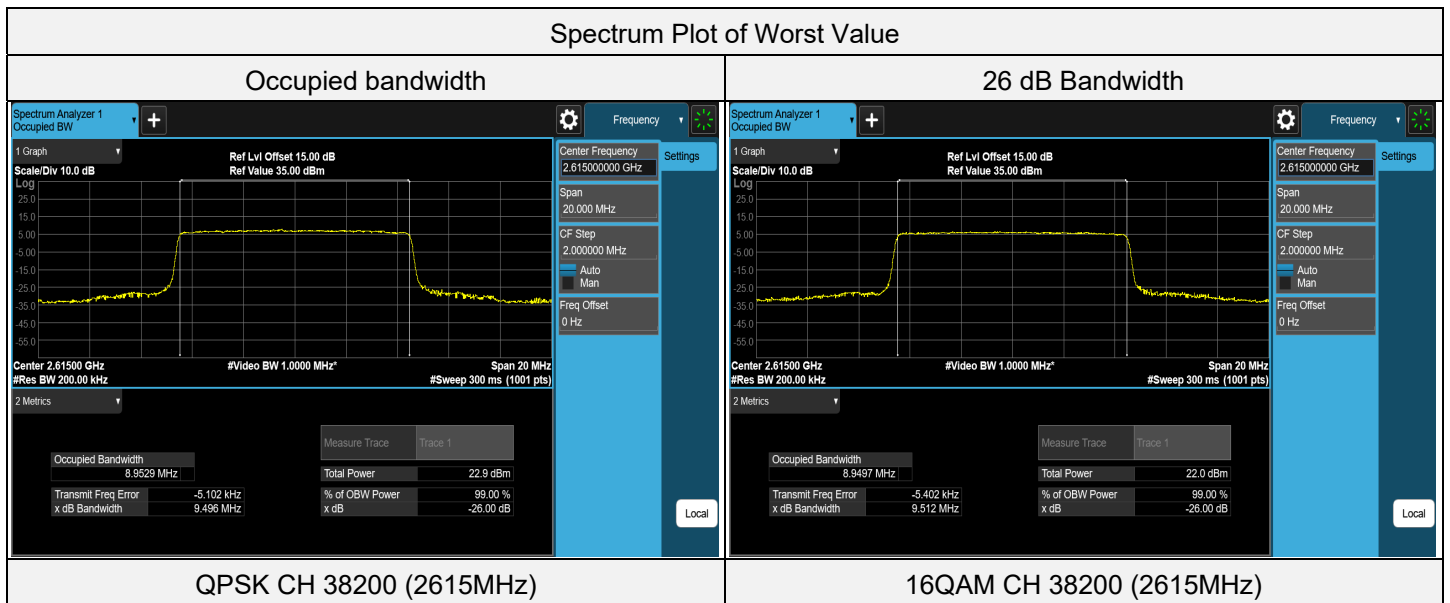

LTE Band 38, Channel Bandwidth: 15 MHz

Test Condition	Channel	Frequency (MHz)	Occupied bandwidth (MHz)	26 dB Bandwidth (MHz)
QPSK	37825	2577.5	13.3998	14.228
QPSK	38000	2595	13.4235	14.230
QPSK	38175	2612.5	13.4301	14.229
16QAM	37825	2577.5	13.4232	14.245
16QAM	38000	2595	13.4239	14.215
16QAM	38175	2612.5	13.4278	14.217

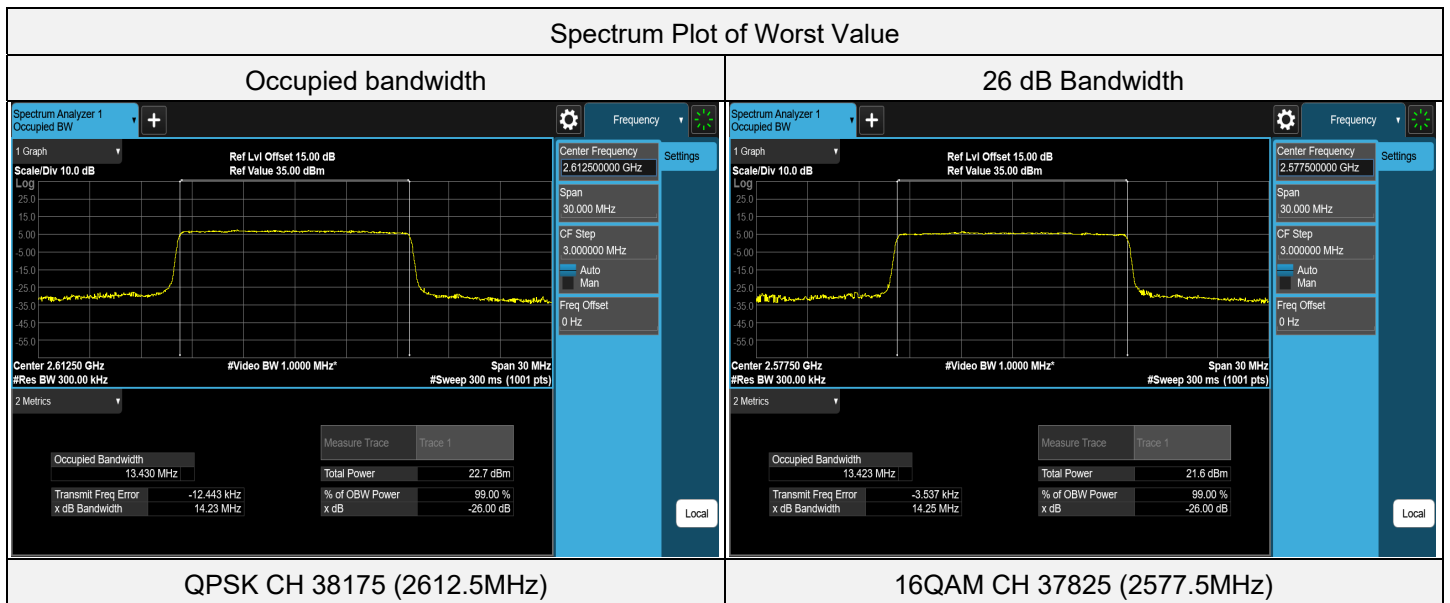



LTE Band 38, Channel Bandwidth: 20 MHz

Test Condition	Channel	Frequency (MHz)	Occupied bandwidth (MHz)	26 dB Bandwidth (MHz)
QPSK	37850	2580	17.8674	18.993
QPSK	38000	2595	17.8767	19.002
QPSK	38150	2610	17.8785	18.995
16QAM	37850	2580	17.8705	19.001
16QAM	38000	2595	17.8702	18.992
16QAM	38150	2610	17.8813	19.006

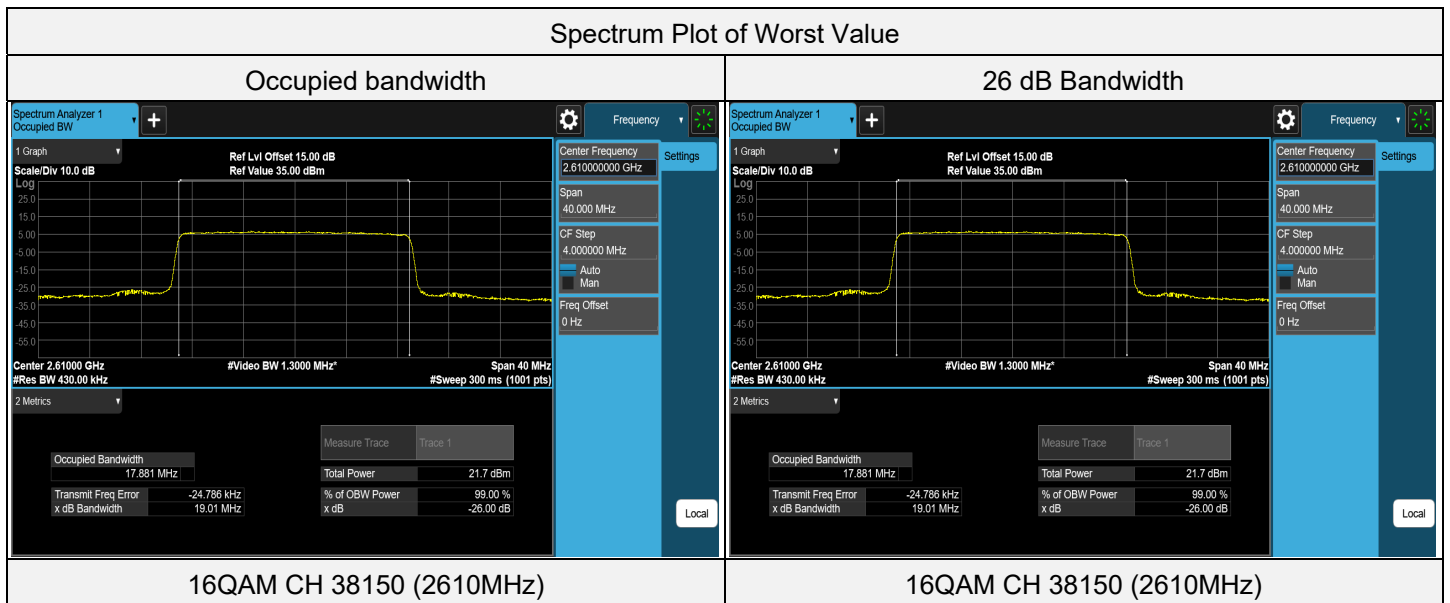

7.4.7 LTE Band 41

LTE Band 41, Channel Bandwidth: 5 MHz

Test Condition	Channel	Frequency (MHz)	Occupied bandwidth (MHz)	26 dB Bandwidth (MHz)
QPSK	40265	2557.5	4.4872	4.822
QPSK	40690	2600	4.4949	4.827
QPSK	41215	2652.5	4.4959	4.849
16QAM	40265	2557.5	4.4856	4.795
16QAM	40690	2600	4.4902	4.827
16QAM	41215	2652.5	4.4882	4.819

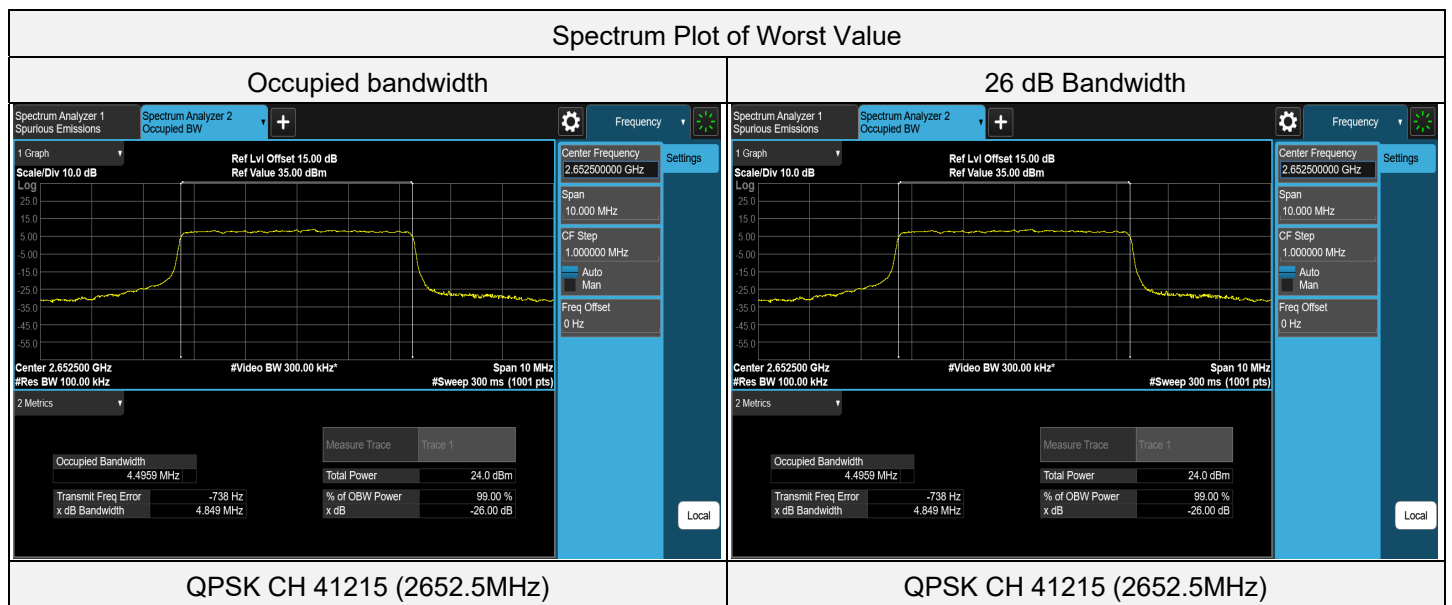

LTE Band 41, Channel Bandwidth: 10 MHz

Test Condition	Channel	Frequency (MHz)	Occupied bandwidth (MHz)	26 dB Bandwidth (MHz)
QPSK	40290	2560	8.9578	9.499
QPSK	40690	2600	8.9440	9.502
QPSK	41190	2650	8.9501	9.500
16QAM	40290	2560	8.9558	9.516
16QAM	40690	2600	8.9622	9.520
16QAM	41190	2650	8.9583	9.512

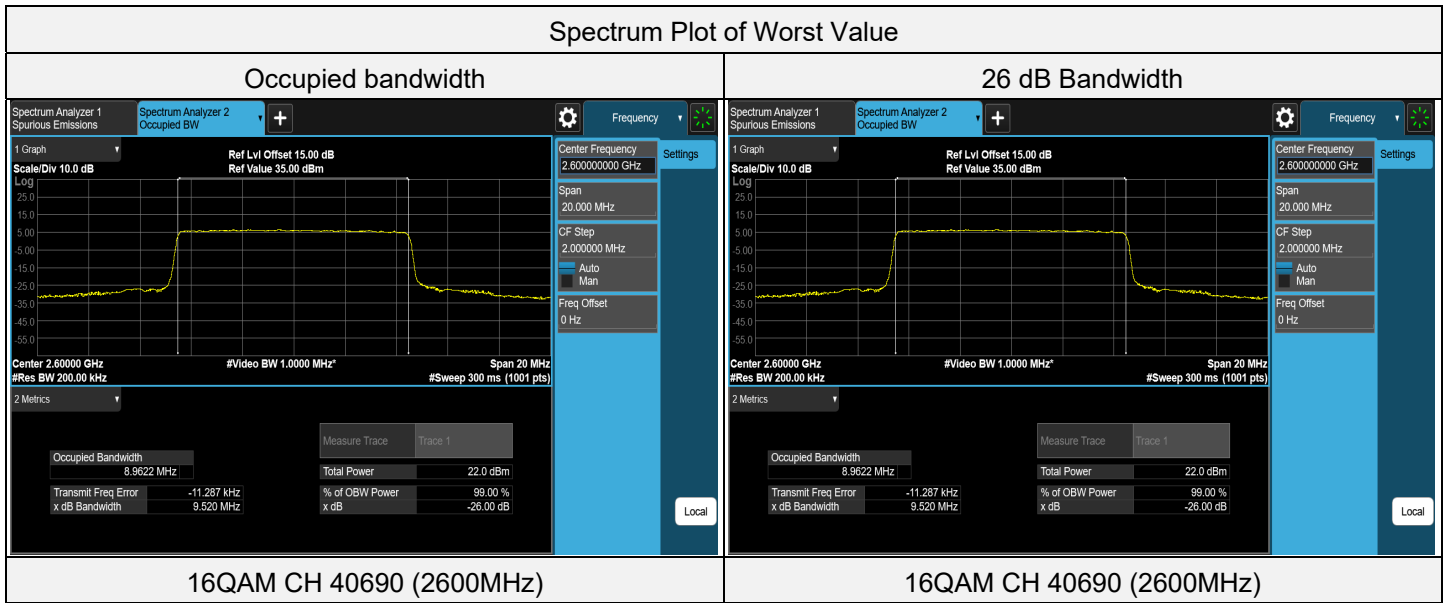

LTE Band 41, Channel Bandwidth: 15 MHz

Test Condition	Channel	Frequency (MHz)	Occupied bandwidth (MHz)	26 dB Bandwidth (MHz)
QPSK	40315	2562.5	13.4319	14.245
QPSK	40690	2600	13.4225	14.225
QPSK	41165	2647.5	13.4218	14.228
16QAM	40315	2562.5	13.4295	14.236
16QAM	40690	2600	13.4321	14.235
16QAM	41165	2647.5	13.4261	14.232

