

Parts Specification Cover

| | |
|--------------|---------------------------|
| Customer | Wistron Neweb Corporation |
| WNC P/N | 08.22100.018 |
| Supplier | RF21.S00940A |
| Brand | RFLINK |
| Supplier P/N | RFLINK |
| Revision | 1 |

| MFG | ADDRESS | TEL |
|-----------------------|------------------|---------------|
| Site 1 : Factory Name | 东莞市塘厦镇清湖头三坑工业区1号 | 0769-38940168 |
| Site 2 : Factory Name | | |
| Site 3 : Factory Name | | |

| | | |
|----------|----------|----------|
| approval | reviewer | prepared |
| 姚定军 | 田佳 | 刘莹 |

承 认 书

SPECIFICATION FOR APPROVAL

客户名称

CUSTOMER NAME: 启基

产品名称

PRODUCT NAME: 5GNR 白色 SMA 天线

客户料号

CUSTOMER P/N: 08.22100.018

仁丰料号

Ren Feng P/N: RF21S00940A REV: A

内部结构

Internal structure: 全 PCB

| | MANUFACTURER SIGNATURE | CUSTOMER SIGNATURE |
|--------------|---------------------------|-----------------------|
| CHECKED BY: | 刘莹 | |
| AUDITOR BY: | 田佳 | |
| APPROVED BY: | 姚定军 | |
| DATE: | 2020-07-28 | |

Contents

| <i>Description</i> | <i>Page</i> |
|-----------------------------------|-------------|
| 1、封面 Cover ----- | 1-2 |
| 2、履历表 Resume ----- | 3 |
| 3、目录 Contents----- | 4-6 |
| 4、规格表 Specifications sheets ----- | 7 |
| 5、成品图 End product chart ----- | 8-9 |
| 6、产品零件图Product partsdrawing----- | 10-15 |
| 7、测试报告 Testing report ----- | 16-18 |
| 8、材质证明 Material description ----- | 19-32 |
| 9、FAI /CPK----- | 33-35 |
| 9、可靠性报Reliabilityreport ----- | 36-64 |

| | | | | | |
|-----------------------------|---|----------------------------|--------------------|-------------------------|----------------|
| 料號 Part Number | 08.21100.018 | 圖面版次 Version of Drawing | 1 | 提交日期 Submission Date | 2020/07/12 |
| 品名 Name | RF21S00940A | 適用機種 Model | XKAX-M04 | | |
| 檢附文件確認表 Documents Checklist | | | | | |
| 確認項目 Items Confirm | 應附文件 Attachments | | | | 確認結果 Result |
| 材料 Materials | 原廠材料證明或材料物性表 | | | | OK |
| 尺寸量測 Dimension | 全尺寸量測報告 (FAI report) | | | | OK |
| 製程能力 Process Capability | Cp/Cpk 報告(CpK > 1.33) | | | | OK |
| 外觀色差 Color Difference | 1. 測試方式：色差值比對客戶承認樣品/色板 標準值L=99.65, a=0.4, b=-4.95 2. 判定標準： L±1.3, a±0.8, b±0.8, E≤1.5 | | | | OK |
| 外觀光澤度 Glossiness | 比對客戶承認樣品/規格 | | | | OK |
| 外觀咬花 Texture | 比對客戶承認樣品/規格 | | | | OK |
| 印刷正確性 Printing Accuracy | 比對客戶承認樣品、圖面內容、尺寸 | | | | NA |
| 印刷油墨 Printing Ink | 1. 測試方式：依顏色限度樣品之色差值比對(目視為主、色差值為輔) 2. 判定標準：△L±1.0, △a±0.6, △b±0.6, △E≤1.2 | | | | NA |
| 印刷耐磨性 Abrasion Eraser | 1. 測試方式：橡皮擦測試，以500g法碼荷重測試，60 cycle/min來回 2. 判定標準：100 次來回，表面不可脫落、變色、見底材 | | | | NA |
| 印刷耐磨性 Alcohol Test | 1. 測試方式：酒精棉布擦拭(濃度≥95%)，以500g法碼荷重測試，60 cycle/min來回 2. 判定標準：100 次來回，表面不可脫落、變色、見底材 | | | | NA |
| 印刷百格 Cross-Cut | 1. 測試方式：百格刀切割間距1mm交叉方格，3M#610黏貼後，180度快速反拉 2. 判定標準：要求附著力 ≥ 4B，即脫落總面積小於5%為合格 | | | | NA |
| 折彎測試 Bending | 1. 測試方式：彎折測試500次 (from 0 degree to maximun degree) 2. 判定標準：Hinge能任意角度固定，且推力值落於 500 ~ 1000 gf | | | | OK |
| 旋轉測試 Rotating | 1. 測試方式：從彎折軸線上5.0 cm進行推力，旋轉順時鐘1圈為1次，測試300次 2. 判定標準：且扭力值落於 0.25 ~ 0.6 kgf.cm | | | | OK |
| Hinge耐拉拔 Hinge Pull-Out | 1. 測試方式：固定鎖附接頭，進行反方向拉拔，至少承受 > 8.0 kgf 2. 判定標準：接頭和本體不能分離，外殼無破裂、鉚釘凸出、變形等 | | | | OK |
| Hinge鎖附力 Hinge Torque | 1. 測試方式：固定鎖附接頭(扭力計)，進行旋轉鎖附 2. 判定標準：SMA鎖附扭力落於 1.0 ~ 2.5 kgf.cm | | | | OK |
| 線材耐拉拔 Cable Pull-Out | 1. 測試方式：固定線材，進行反方向拉拔，至少承受 > 2.0 kgf 2. 判定標準：線材和本體外殼不能分離，測試後電特性正常 | | | | NA |
| IPEX耐拉力 Wire Crimp | 1. 測試方式：固定IPEX接頭，進行線材反方向拉拔，至少承受 > 2.0 kgf 2. 判定標準：IPEX接頭和線材本體不能分離，測試後電特性正常 | | | | NA |
| 推壓測試 Push Test | 1. 測試方式：產品放置桌面，彎折軸線上5.0 cm進行推壓外殼，測試本體外殼強度 2. 判定標準：施力 > 5.0 kgf，外殼無破裂、鉚釘凸出、變形等 | | | | OK |
| 推壓測試 Push Test | 1. 測試方式：SMA鎖附後，彎折軸線上5.0 cm進行推壓外殼，測試Hinge保持力強度 2. 判定標準：施力 > 1.5 kgf，Hinge無分離、鉚釘凸出、變形等 | | | | OK |
| 搖晃異音 Abnormal noise | 確認組裝後是否有不正常的晃動異音 | | | | OK |
| 組配斷差 Assembly gap | 比對客戶承認樣品/規格 | | | | OK |
| 外觀簽樣 Appearance | 標準樣品(或限度樣品)，已取得客戶標準樣品，簽樣留底 | | | | OK |
| 備註 Remark | | | | | |
| 審核 Approved by | 供應商審核人員 | | 承辦 Processed by | 供應商承辦人員 | |

| | | | | | |
|-------------------|--------------|----------------------------|----------|-------------------------|------------|
| 料號 Part Number | 08.22100.018 | 圖本版次 Version of Drawing | 1 | 提交日期 Submission Date | 2020/07/12 |
| 品名 Name | RF21S00940A | 適用機種 Model | XKAX-M04 | | |

檢附文件確認表 Documents Checklist

| 確認項目 Items Confirm | 應附文件 Attachments | 確認結果 Result | |
|-----------------------|---|--------------------|---------|
| 高溫儲存 | 1. 測試方式：溫度：+ 70 °C、時間：72 hrs. 2. 判定標準：無外觀變形或異常現象 | OK | |
| 低溫儲存 | 1. 測試方式：溫度：- 40 °C、時間：72 hrs. 2. 判定標準：無外觀變形或異常現象 | OK | |
| 高溫高濕 | 1. 測試方式：溫度/濕度：+ 70 °C/ 90 %Rh、時間：96 hrs. 2. 判定標準：無外觀變形或異常現象 | OK | |
| 溫度衝擊/循環 | 1. 測試方式：溫度：- 40 °C ~ + 70 °C、時間：60 mins / temp.、次數：20 cycles. 2. 判定標準：無外觀變形或異常現象 | OK | |
| 鹽水噴霧 | 1. 測試方式：溫度：+ 35 °C、次數：48 cycles. 2. 判定標準：無外觀生鏽或異常現象 | NA | |
| 防水試驗 | 1. 測試方式：依據 IEC60529 IPx7(水深：1 m、時間：0.5 hrs.) 2. 判定標準：無本體浸水或異常現象、驗證功能正常 | NA | |
| 防塵試驗 | 1. 測試方式：依據 IEC60529 IP5x(時間：8 hrs.) 2. 判定標準：不得因落入之灰塵影響正常功能 | NA | |
| UV照射 | 1. 測試方式：UV Irradiance：0.89 W/m ² /nm、Wavelength：340nm.、時間：8 hrs. 2. 判定標準：無外觀變形或異常現象(色差ΔE<5.0) | NA | |
| 單品落下試驗 | 1. 測試方式：高度：100 cm、地板：混凝板、共6個面。 2. 判定標準：無外觀變形或異常現象、驗證功能正常 | OK | |
| 單品振動試驗 正弦 Sine | 1. 測試方式：頻率5 ~ 62Hz for 5 mm/s、62 ~ 200Hz for 2 ms ² 、5 Sweeps for 3 axis. 2. 判定標準：無外觀變形或異常現象、驗證功能正常 | NA | |
| 單品振動試驗 隨機 Random | 1. 測試方式：頻率5~10Hz for + 12 (dB/oct)、50 ~ 100Hz for - 12 (dB/oct)、30 mins/ axis 2. 判定標準：無外觀變形或異常現象、驗證功能正常 | OK | |
| 包材落下試驗 | 1. 測試方式：高度：81 cm、衝擊面：鐵板、1 角, 3 線, 6 面 (共10 次)。(參照ISTA 2A) 2. 判定標準：無破裂或異常現象、驗證功能正常 | OK | |
| 包材振動試驗 | 1. 測試方式： 頻率: 5 Hz for 0.01 (g ² /Hz) 頻率:100 Hz for 0.01 (g ² /Hz) 頻率:200 Hz for 0.001 (g ² /Hz)、60 mins/ axis(參照ISTA 2A) 2. 判定標準：無破裂或異常現象、驗證功能正常 | OK | |
| | | | |
| | | | |
| | | | |
| | | | |
| | | | |
| | | | |
| | | | |
| | | | |
| 備註 Remark | | | |
| 審核 Approved by | 供應商審核人員 | 承辦 Processed by | 供應商承辦人員 |

产品主要技术参数

| 主要技术指标 | | Main technical specifications | |
|------------------|---|-------------------------------|---|
| 频率范围 (MHZ) | 699-698 699-960 1710-2690 3300-4200 5150-5925 | Frequency Range (MHZ) | 699-698 699-960 1710-2690 3300-4200 5150-5925 |
| 特性阻抗(Ω) | 50 \pm 10 | Impedance(Ω) | 50 \pm 10 |
| 增益(dBi) | 2 \pm 0.5 | Gain(dBi) | 2 \pm 0.5 |
| 反射损耗 | \leq -6 | ReTurnLoss(dB) | \leq -6 |
| 输出电压 驻波比 | \leq 6.0 \leq 3.5 | VSWR | \leq 6.0 \leq 3.5 |
| 最大功率 | 1W | Admitted Power | 1W |
| 极化方式 | 垂直极化 | Polarization | Linear, Vertical |
| 方向性 | 全向性 | Radiation | Omni-directional |
| 连接方式 | SMA | Connector Type | SMA |
| 物理性能 | | Physical Properties | |
| 天线本体材料 | ABS | Antenna Base | ABS |
| 工作温度 | -40 $^{\circ}$ C \sim +70 $^{\circ}$ C | Operating Temp | -40 $^{\circ}$ C \sim +70 $^{\circ}$ C |
| 保存温度 | -40 $^{\circ}$ C \sim +70 $^{\circ}$ C | Storage Temp | -40 $^{\circ}$ C \sim +70 $^{\circ}$ C |

| REV | DATE | DESCRIPTION |
|-----|------------|-------------|
| A | 2020-06-30 | NEW ISSUE |

137±3

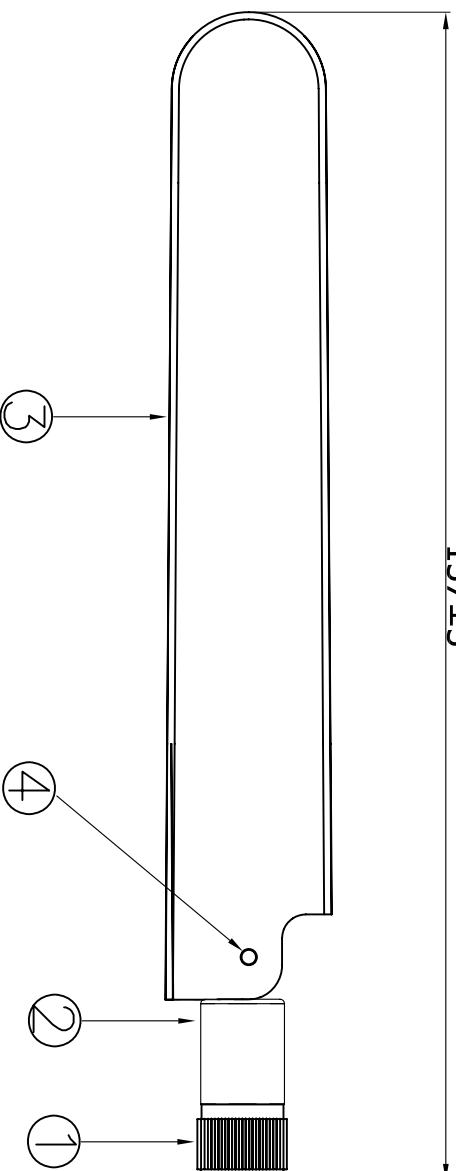

110±3

∅9.35±0.1

36.5±1

116±3

规格 (Specification) :
 频率 (Frequency Range) : 617~698MHz
 驻波比 (VSWR) : 6.0max
 规格 (Specification)
 频率 (Frequency Range) : 699~960MHz
 1710~2690MHz
 3300~4200MHz
 5150~5925MHz

驻波比 (VSWR) : 3.5max
 工作温度: -40°C~+70°C
 保存温度: -40°C~+70°C

| NO. | DESCRIPTION | Q'TY | REMARK |
|-----|-------------|------|--------------------------------|
| 1 | SMA接头 | 1 | SMA PLUG, PIN (M) ; BRASS |
| 2 | 固定座 | 1 | PC+PBT ; (新光A724) ; White |
| 3 | 杆套 | 1 | ABS ; (奇美PA-757) White (VD124) |
| 4 | 铆钉 | 2 | POM; M90-44 ; White |

| | | | |
|-----------|--------|----------|--------------------------------|
| 尺寸范围(mm) | 公差(mm) | APPROVED | CUSTOMER: |
| 0<L≤6 | ±0.10 | | PART NO : |
| 6<L≤30 | ±0.10 | | PARTNAME : RF Antenna Assembly |
| 30<L≤90 | ±0.15 | CHECKED | R.F P/NO : RF21S00940A |
| 80<L≤180 | ±0.20 | | REV |
| 180<L≤315 | ±0.25 | DRAWING | UNIT |
| 315<L≤800 | ±0.35 | 田佳 | SCALE |
| 如原 | ±0.5 | | SIZE |
| | | | SHEET |
| | | | 10F1 |

| | |
|------------------|--|
| 产品符合环保RoHS2.0之要求 | |
|------------------|--|

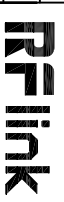

东莞市仁丰电子科技有限公司
 RenFeng Electronic technology Co., LTD.

产品包装

| REV | DATE | DESCRIPTION |
|-----|------------|-------------|
| A | 2020-07-28 | NEW ISSUE |

单个产品



- 内袋包装说明：
- 1.每袋装入20pcs产品。
 - 2.PE袋进行封口。
 - 3.每袋需贴1pc客户指定标签以及1pc的RoHS标签

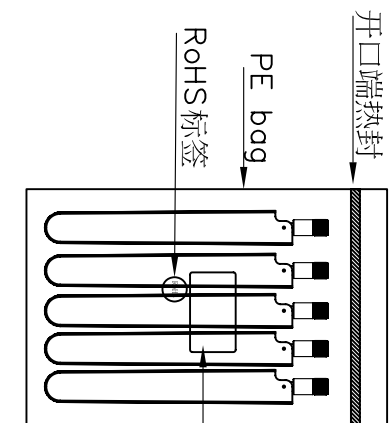

内袋包装



1pc平卡需放纸箱底层

外箱包装

- 外箱包装说明：
- 1.纸箱底层需放1pc平卡，纸箱四个角需各放1pc护角纸。
 - 2.外箱需贴1pc外箱标签，在侧面（规格描述面）的左上角位置。
 - 3.RoHS标签需外箱标签右下角外置。
 - 4.纸箱尺寸：长350mm*宽300mm*高200mm
 - 5.每箱装25袋产品，共计装500pcs产品每箱。

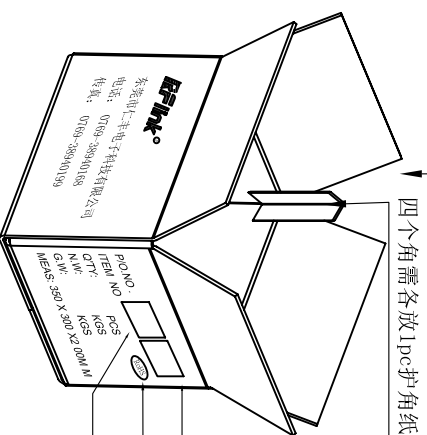

外箱标签
RoHS标签
2S 标签

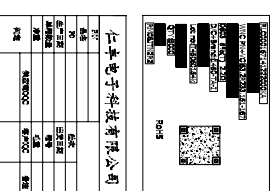

| 尺寸范围 (mm) | 公差 (mm) |
|--------------------|---------|
| 0.01 ≤ D < 0.1 | ±0.10 |
| 0.1 ≤ D < 0.3 | ±0.15 |
| 0.3 ≤ D < 0.5 | ±0.20 |
| 0.5 ≤ D < 1.0 | ±0.30 |
| 1.0 ≤ D < 3.0 | ±0.40 |
| 3.0 ≤ D < 6.0 | ±0.50 |
| 6.0 ≤ D < 30.0 | ±0.63 |
| 30.0 ≤ D < 100.0 | ±0.75 |
| 100.0 ≤ D < 300.0 | ±0.90 |
| 300.0 ≤ D < 1000.0 | ±1.00 |

| | |
|----------|---------|
| APPROVED | CHECKED |
| DRAWING | 田佳 |

| NO | DESCRIPTION | QTY | REMARK |
|------------------------|-------------|-------|--------|
| CUSTOMER: | | | |
| PART NO : | | | |
| PARTNAME : 天线包装 | | | |
| R.F P/NO : RF21S00940A | | | |
| REV | UNIT | SCALE | SIZE |
| A | mm | 1 : 1 | A4 |
| | | | SHEET |
| | | | 20F2 |

RFlink
东莞市仁丰电子科技有限公司
RenFeng Electronic technology
Co., LTD.

产品符合环保RoHS2.0之要求

| REV | DATE | DESCRIPTION |
|-----|------------|-------------|
| A | 2020-06-30 | NEW ISSUE |

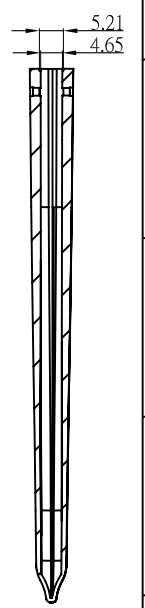
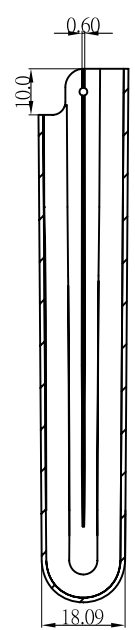
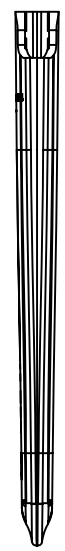
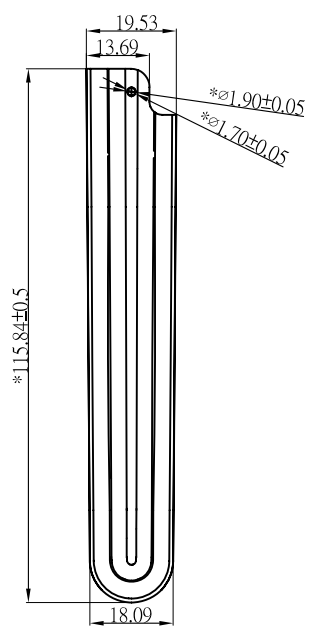

- 备注:
- 1、材质: ABS
 - 2、颜色: 白色 (依客人色板)
 - 3、产品不能有披锋、顶白、刮花、缩水、气纹等不良。
 - 4、带*尺寸为检验尺寸, 做为IQC检验项目
 - 5、带 □ 为CPK尺寸
 - 6、其他未注公差尺寸按照仁丰实配要求为准
 - 7、产品需符合RoHS2.0环保要求

| 公差 | ± A | ± B | ± C |
|------------------|------|------|------|
| 0 - 6 | 0.05 | 0.07 | 0.10 |
| >6 - 30 | 0.10 | 0.15 | 0.20 |
| >30 - 60 | 0.15 | 0.20 | 0.25 |
| >60 - 120 | 0.20 | 0.25 | 0.30 |
| >120 - 180 | 0.25 | 0.30 | 0.40 |
| >180 - 300 | 0.30 | 0.40 | 0.50 |
| >300 - 500 | 0.40 | 0.50 | 0.60 |
| ANGLE TOL + 0.50 | | | |

APPROVED
CHECKED
DRAWING
陈迪

VENDER :
PART NO :
PARTNAME : S64杆套
P/NO : 300A01310A
REV UNIT SCALE SIZE SHEET
A mm 1:1 A 4 1 OF 1

RF link
东莞市仁丰电子科技有限公司
RenFeng Electronic technology
Co., LTD.

| REV | DATE | DESCRIPTION |
|-----|------------|-------------|
| A | 2020-06-30 | NEW ISSUE |

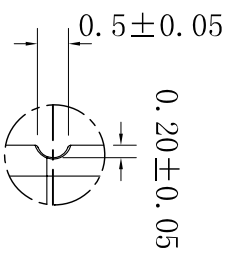
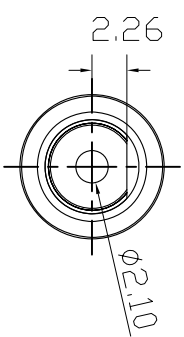
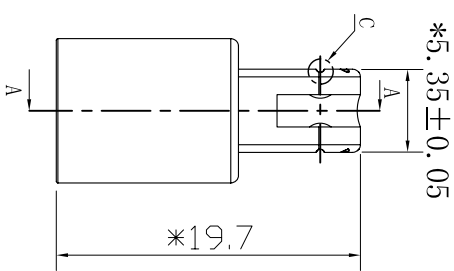
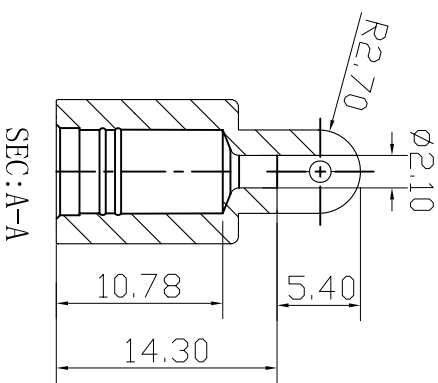
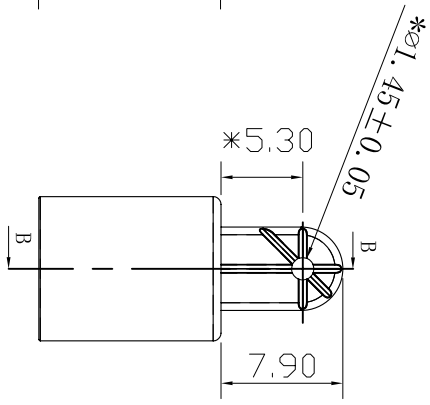
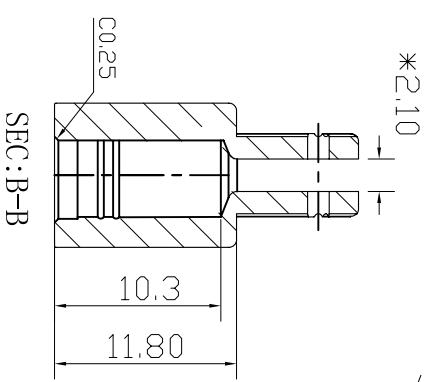
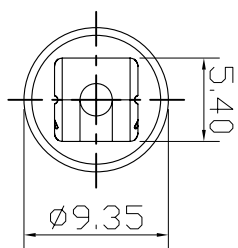

DETAIL C
SCALE=4/1

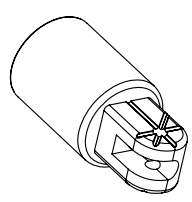

- 备注:
- 1、材质: PC+PBT
 - 2、颜色: 白色 (依客人色板)
 - 3、产品不能有披锋、顶白、刮花、缩水、气纹等不良。
 - 4、带*尺寸为检验尺寸, 做为IQC检验项目
 - 5、带□为CPK尺寸
 - 6、其他未注公差尺寸按照仁丰实配要求为准
 - 7、产品需符合RoHS2.0环保要求

| select | ± A | ± B | ± C | APPROVED |
|-----------------|------|------|------|----------|
| 0 ~ 6 | 0.05 | 0.07 | 0.10 | CHECKED |
| >6 ~ 5 | 0.08 | 0.10 | 0.15 | |
| >5 ~ 30 | 0.10 | 0.12 | 0.20 | DRAWING |
| >30 ~ 60 | 0.12 | 0.20 | 0.25 | |
| >60 ~ 120 | 0.15 | 0.25 | 0.35 | 陈迪 |
| >120 ~ 180 | 0.20 | 0.30 | 0.40 | |
| >180 ~ 300 | 0.25 | 0.35 | 0.50 | |
| >300 ~ 500 | 0.30 | 0.40 | 0.60 | |
| MIGT TOL + 0.50 | | | | |

| VENDER : | | PART NO : | | PARTNAME : | |
|------------|------|------------|------|------------|--|
| | | | | 下固定座 | |
| R.F P/NO : | | 300A01311A | | | |
| REV | UNIT | SCALE | SIZE | SHEET | |
| A | mm | 1:1 | A4 | 1 OF 1 | |

Rlink
 东莞市仁丰电子科技有限公司
 RenFeng Electronic Technology
 Co., LTD.

| REV | DATE | DESCRIPTION |
|-----|-----------|-------------|
| A | 2015-12-3 | New Issue |

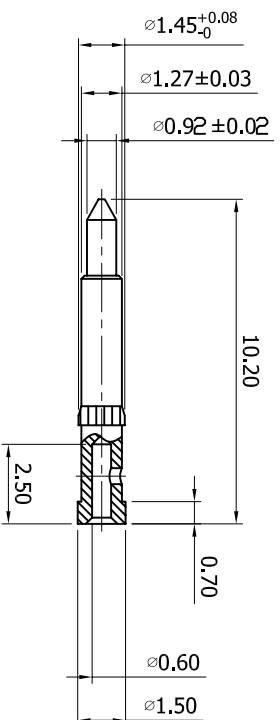
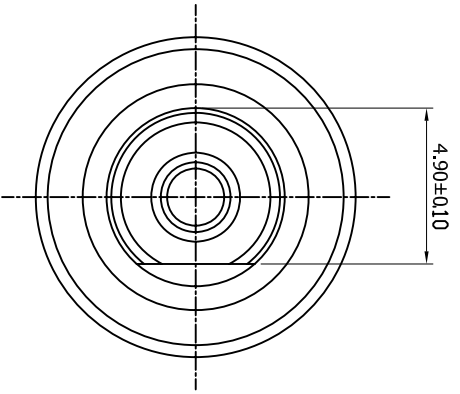
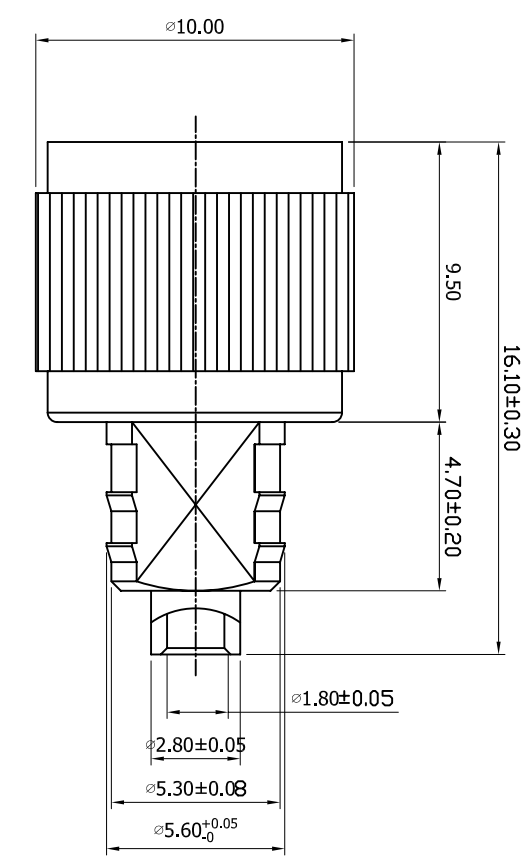

技术要求:

- 1) 标准阻抗: 50 OHM;
- 2) 频率范围: 0~6 GHz;
- 3) 电压驻波比: 1.5 MAX;
- 4) 工作电压: 335-500 Volts;
- 5) 电介质耐压: 500-1500 Vrms;
- 6) 绝缘阻抗: 5000 Mohms;
- 7) 本体与连接轴的装配后保持力: 8KG MIN;
- 8) 动态扭力250-600 g_f

| | | | |
|----|-------------|-----|-----------------------------|
| 7 | 螺牙主体 | 1 | φ8.50*8.30 C3604 镀80-120U"镍 |
| 6 | 硅胶圈 | 1 | φ7.00*1.25 PVC 红色硅胶 |
| 5 | 华司 | 1 | φ7.40*0.70 C3604 镀80-120U"镍 |
| 4 | 外壳 | 1 | φ10.0*8.80 POM 白色 |
| 3 | 绝缘体 | 1 | φ4.15*8.00 白色铁弗龙 |
| 2 | 主体 | 1 | φ7.40*12.95 锌合金 镀80-120U"镍 |
| 1 | 中芯料 | 1 | φ1.50*7.80 C3604 镀3U"金 |
| NO | Description | Qty | SURFACE TREATMENT |

| XXX | ±2.0 | APPROVED |
|-----|------|----------|
| XX | ±1.0 | 左 晓 |
| X | ±0.5 | CHECKED |
| .X | ±0.2 | DRAWING |
| .XX | ±0.1 | 牛玉伟 |

| VENDOR | PART NO | SCALE | SIZE | SHEET | FILE NAME |
|--------|---------|-------|------|--------|------------|
| | | 1:1 | A4 | 1 OF 1 | |
| | | | | | Small SMA |
| | | | | | 200C00210A |

RF link

东莞市仁丰电子科技有限公司
RenFeng Electronic
technology Co., LTD.

PRODUCTION DRAWING

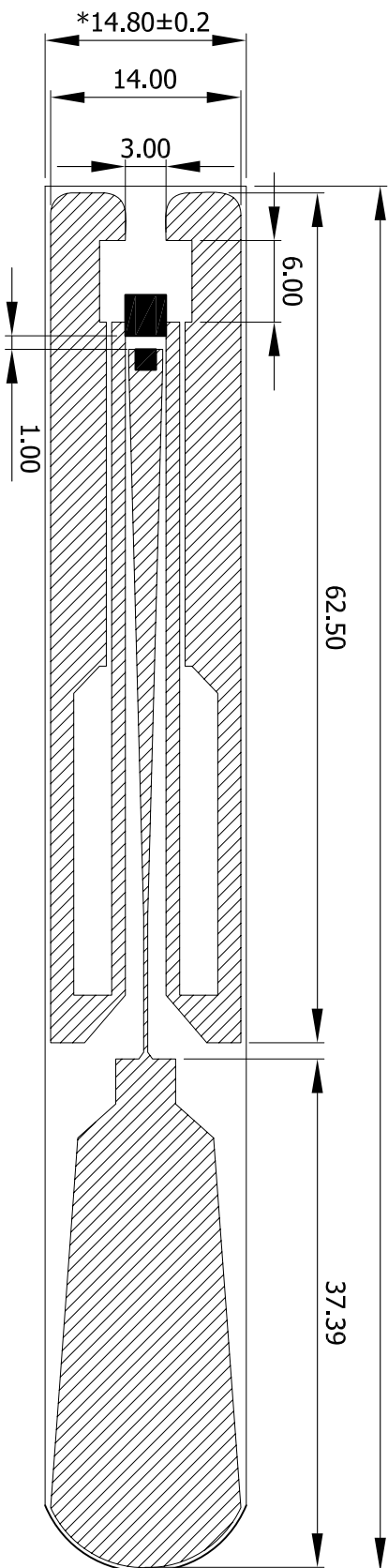

| REV | DATE | DESCRIPTION |
|-----|------------|-------------|
| A | 2019-03-04 | New Issue |
| B | 2020-03-20 | 更改为双面喷黑油 |

*101.91±0.2



RFlink® 732A

Note:

1. 去除所有毛边.
2. 所有边缘和倒角最大C0.15mm.
3. PCB材质: 国纪黄芯料 FR-4.
4. 厚度: 0.8mm; 介电常数: 4.3。
5. 两面印刷黑色油墨;  区域为铜箔;  区域为焊盘区域。
6. 带*为重点管控尺寸
7. 产品需符合RoHS2.0环保要求

| NO | DESCRIPTION | MATERIAL | QTY | P/N | REMARK |
|---|-------------|----------|------|--------|-----------|
| XXX. | ±2.0 | APPROVED | | | |
| XX. | ±1.0 | | | | |
| X. | ±0.5 | CHECKED | | | |
| .X | ±0.1 | | | | |
| .XX | ±0.05 | DRAWING | | | |
| | | 刘军 | | | |
| REV | UNIT | SCALE | SIZE | SHEET | FILE NAME |
| B | mm | 1:1 | A4 | 1 OF 1 | |
| <p>RFlink 东莞市仁丰电子科技有限公司 RenFeng Electronic technology Co., LTD. PRODUCTION DRAWING</p> | | | | | |

| REV | DATE | DESCRIPTION |
|-----|------------|-------------|
| A | 2020-06-30 | New Issue |

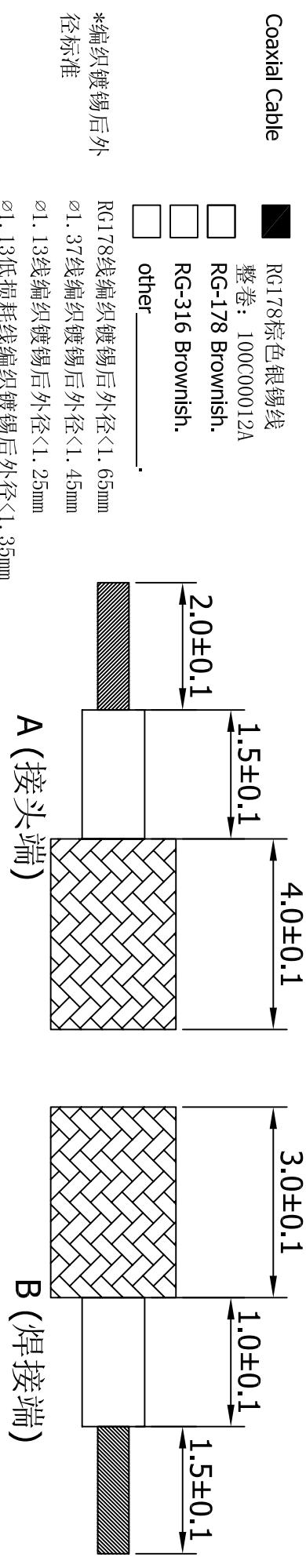
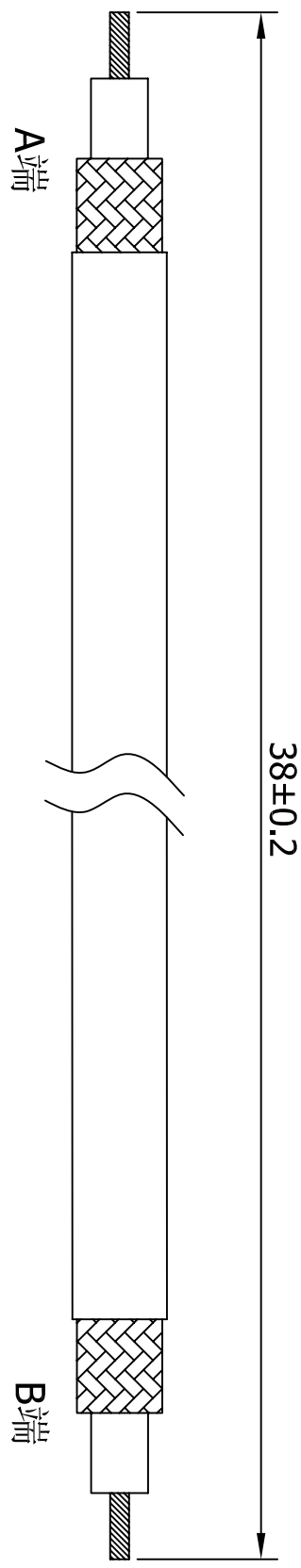

- Coaxial Cable
- RG178棕色银锡线
整卷：100C00012A
 - RG-178 Brownish.
 - RG-316 Brownish.
 - other _____.
- *编织镀锡后外径<1.65mm
 RG178线编织镀锡后外径<1.45mm
 ∅1.37线编织镀锡后外径<1.25mm
 ∅1.13线编织镀锡后外径<1.35mm
 ∅1.13低损耗线编织镀锡后外径<1.35mm

- 编织镀锡
 - 芯线镀锡
 - 端子 (国产)
 - 端子 (I-PEX)
- A B

| | | | |
|------|------|----------|-------------|
| XX. | ±5.0 | APPROVED | CUSTOMER: |
| X. | ±3.0 | CHECKED | PART NO. : |
| .X | ±1.0 | DRAWING | PART NAME: |
| .XX | ±0.5 | | R.F P/NO. : |
| .XXX | ±0.1 | 刘军 | 100C03105A |
| ⊕ | | REV | FILE : |
| ⊖ | | UNIT | SHEET : 1:1 |
| | | mm | |

备注：
 带*为重点管控尺寸；
 带公差尺寸为检验尺寸；
 产品需符合RoHS2.0环保要求；

东莞市仁丰电子科技有限公司
 RenFeng Electronic technology
 Co., LTD.

| REV | DATE | DESCRIPTION |
|-----|------------|-------------|
| A | 2012-11-09 | NEW ISSUE |
| B | 2018-08-27 | 更改材料厚度 |

单边厚度 0.03 ± 0.02

$*125\pm 3$

$*320\pm 5$

5REF

密封位置

- 备注：
1. PE袋要裁切整齐，不可有破损脏污。
 2. 带*尺寸为重点管控尺寸
 3. 产品需符合RoHS2.0环保要求

| | | |
|------|-----------|----------|
| XXX | ± 5.0 | APPROVED |
| XX. | ± 3.0 | CHECKED |
| X. | ± 1.0 | |
| .X | ± 0.5 | |
| .XXX | ± 0.1 | DRAWING |

| | | | |
|-----------------------|-------------|-------|--------|
| 1 | PE bag | 1 | |
| NO | DESCRIPTION | QTY | REMARK |
| CUSTOMER: | | | |
| PART NO : | | | |
| PARTNAME : PE袋 | | | |
| H.L P/NO : 400A00003A | | | |
| REV | UNIT | SCALE | SIZE |
| B | m/m | 1/1 | A4 |
| | | SHEET | 10F1 |

RF link
 东莞市仁丰电子科技有限公司
 RenFeng Electronic technology
 Co., LTD.

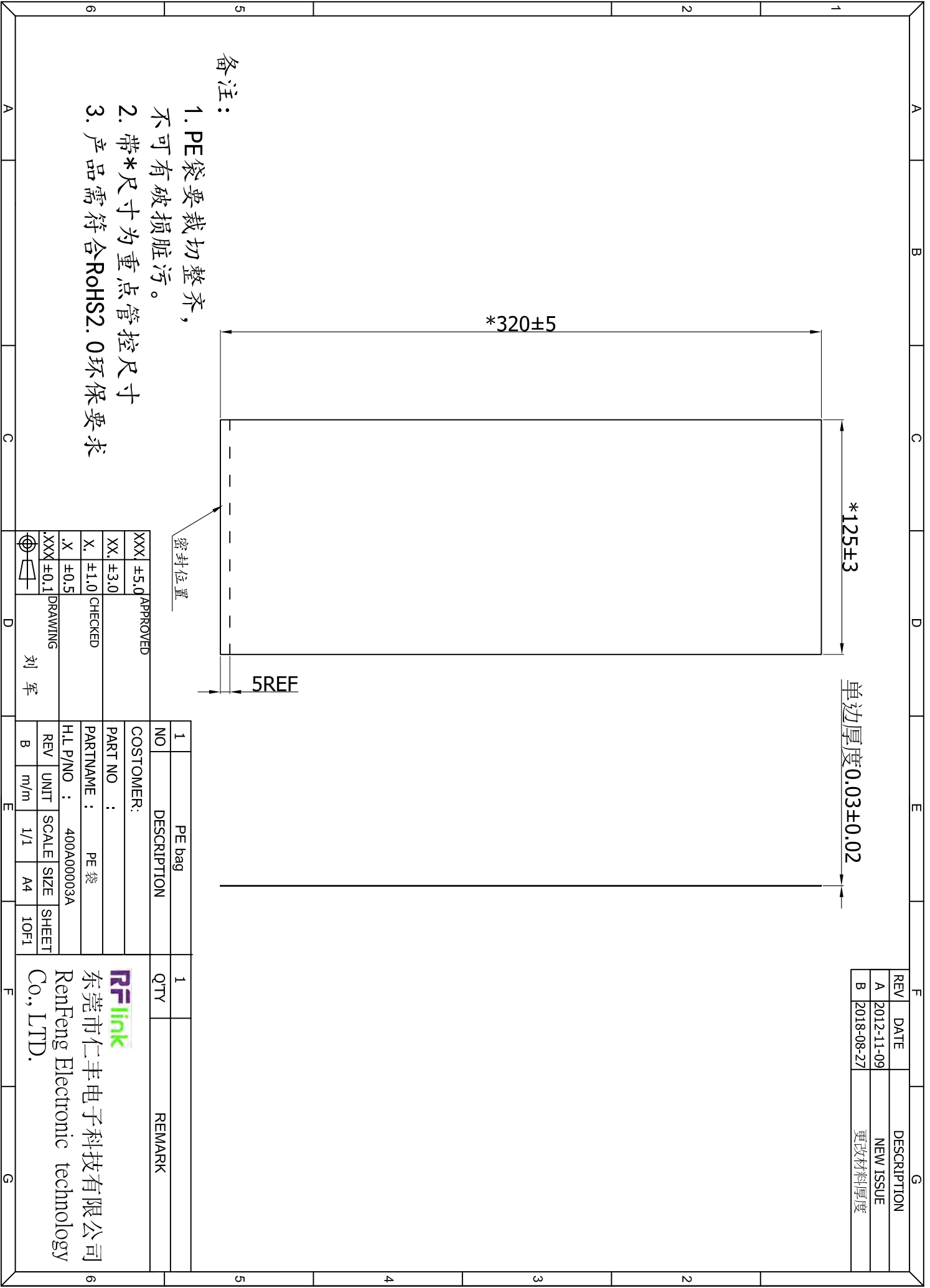

3. 测试报告

3.1: 网络分析仪测试报告:

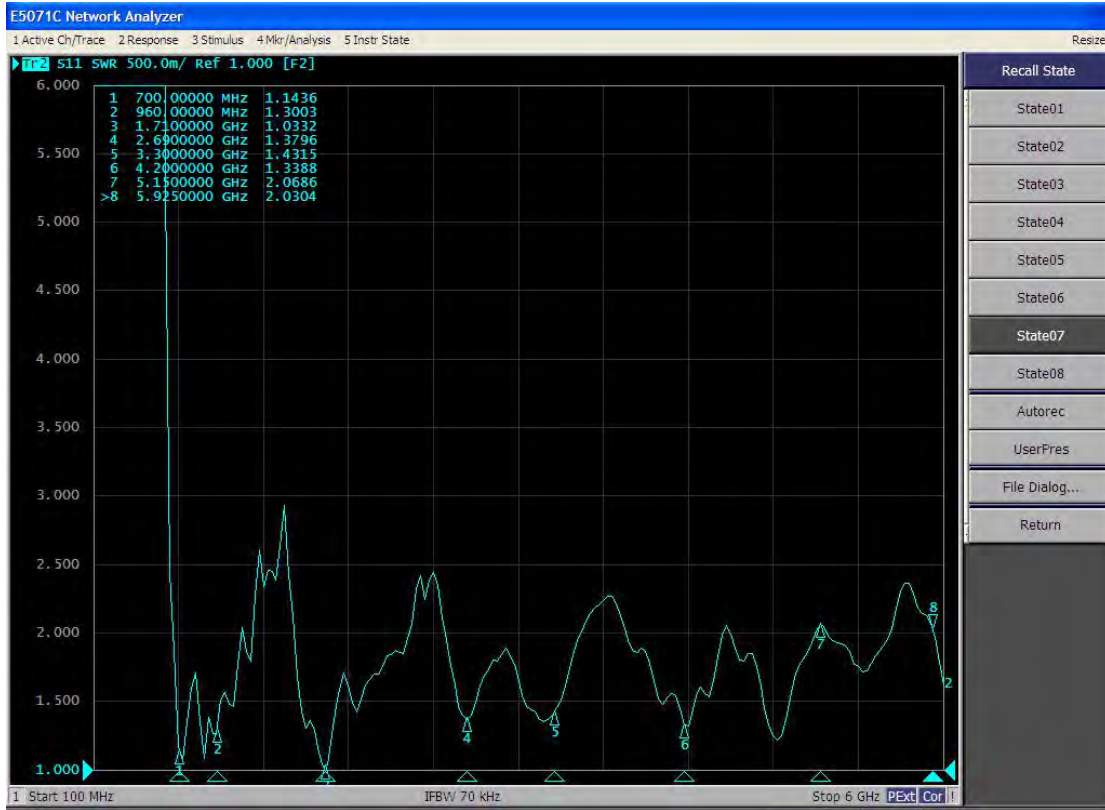

3.2: 暗室 2D、3DRaditation Pattern:

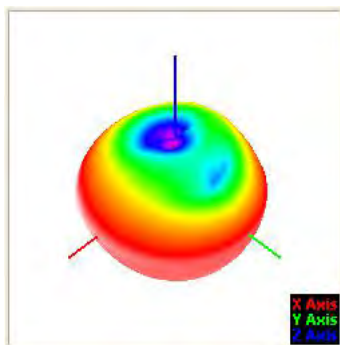

700MHz

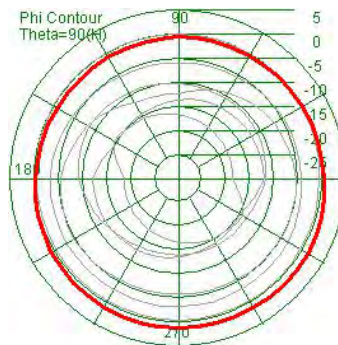

Gain(Peak):1.63dBi

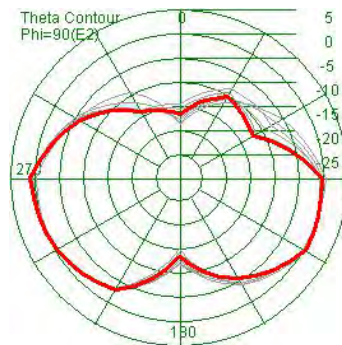

Efficiency68.6%

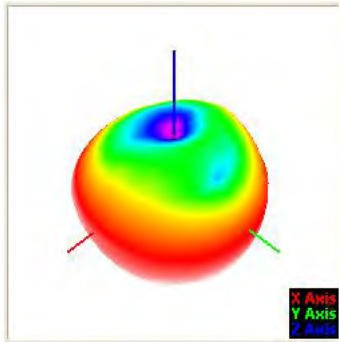

960MHz

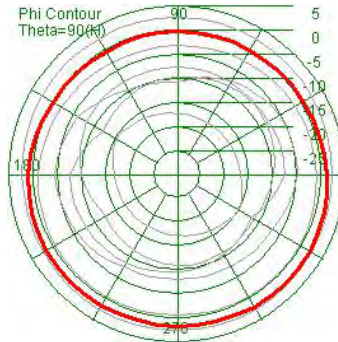

Gain(Peak):2.63dBi

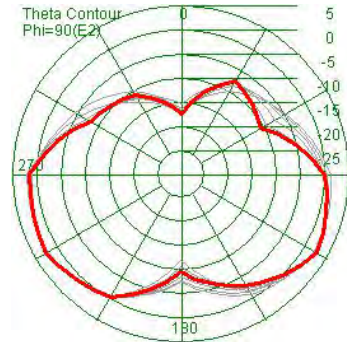

Efficiency:76.7%

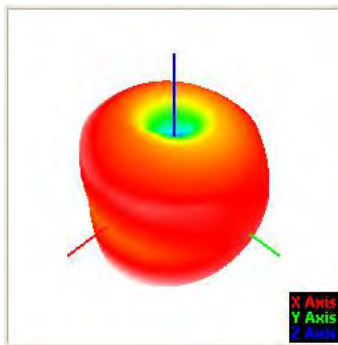

1710MHz

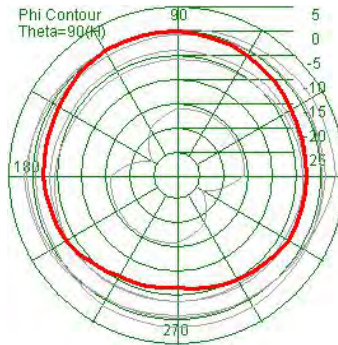

Gain(Peak):2.03dBi

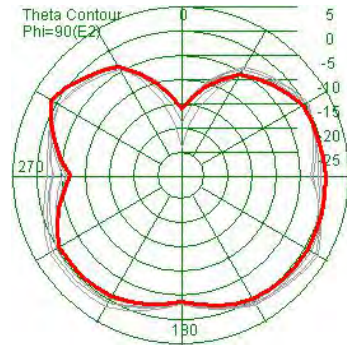

Efficiency:75.9%

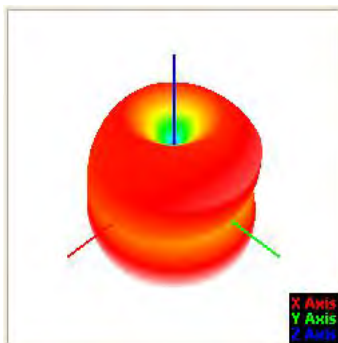

2690MHz

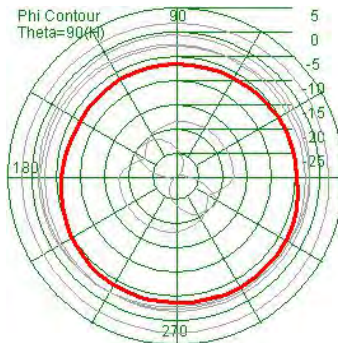

Gain(Peak):2.26dBi

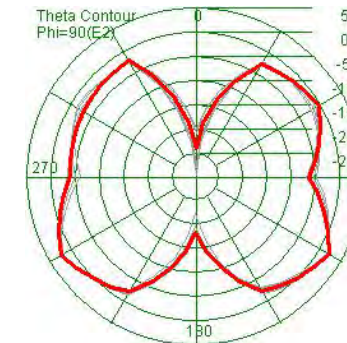

Efficiency:74.7%

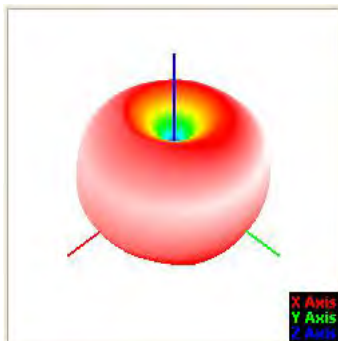

3300MHz

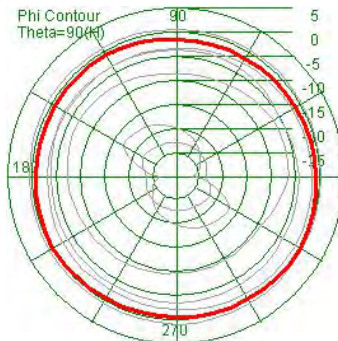

Gain(Peak):1.55dBi

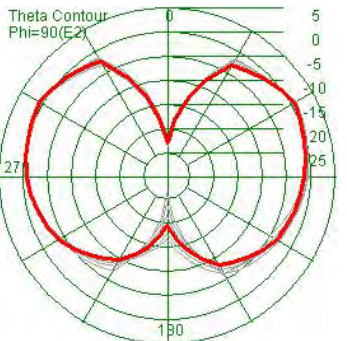

Efficiency:76.3%

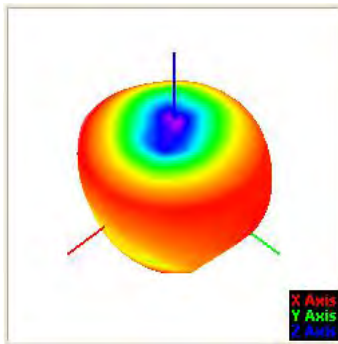

4200MHz

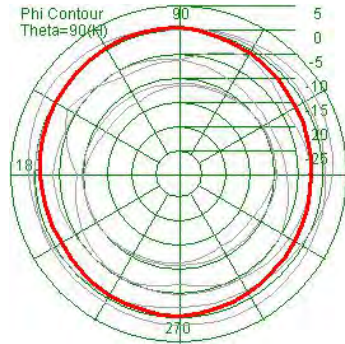

Gain(Peak):2.62dBi

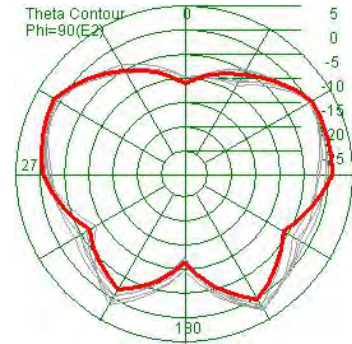

Efficiency:71.2%

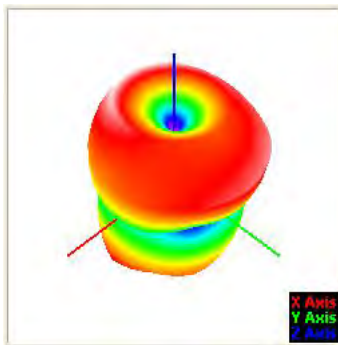

5150MHz

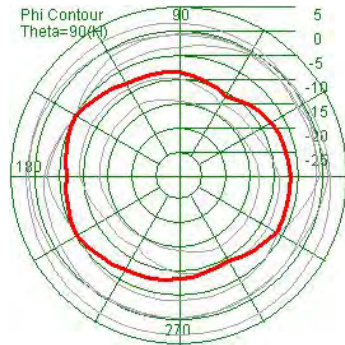

Gain(Peak):2.47dBi

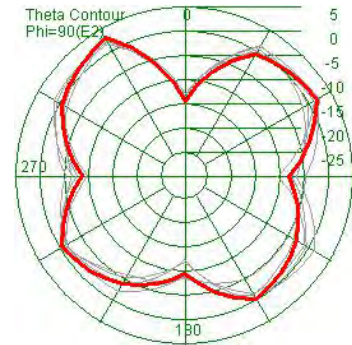

Efficiency:71.5%

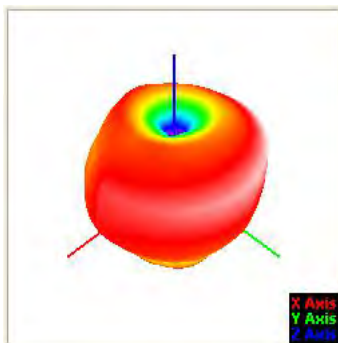

5925MHz

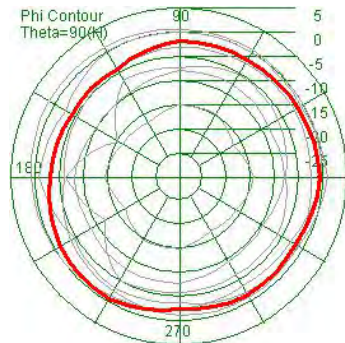

Gain(Peak):1.94dBi

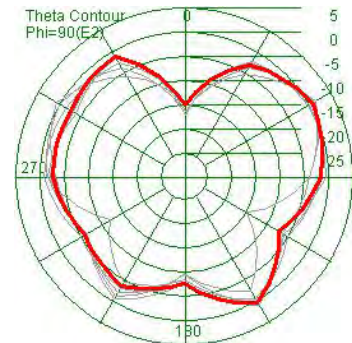

Efficiency:73.4%

深圳市海联通科技有限公司

产品规格书

Product specification

物料 编码: / Material code: 产品 名称: 同轴线缆

Product name:

产品 型号: RG178/E-TC

Product model:

规 格: 7/0.102SCSpecifications:

| 版本号 version number | 修订日期 Revision date | 修订内容 revised contents | 修订人 Revised | 发行日期 date of issue |
|--------------------------|-----------------------|---|----------------|--------------------------|
| A | 2009.10.06 | 新增 new increase | 向明松 | 2009.10.10 |
| B | 2015.03.19 | 修订规格书格式 revised Specification Format | 杨道东 | 2015.03.20 |
| C | | | | |
| D | | | | |
| E | | | | |
| F | | | | |
| 制作 Preparation | | 审核 auditor | 批准 approver | |
| 杨道东 | | 秦荣新 | 张立澎 | |

1. 产品描述

product description

1.1 本产品是 Teflon 绝缘系列柔软同轴电缆线，适用于微波设备、无线通信设备系统和设备。

This product is soft Teflon insulation series coaxial cable. Is suitable for the microwave equipment, wireless communication systems and equipment.

产品特征：极好的柔软性，低驻波比，良好的屏蔽性能，精确的相位匹配。

Product features: Excellent flexi-ability, good V.S.W.R, good shielding performance.

2. 电缆详细资料及结构图：

Cable with data and structure diagram:

2.1 结构图：

1structure diagram

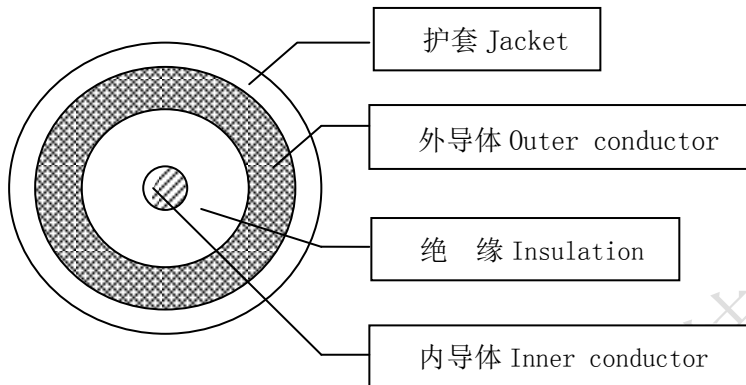

2.2 电缆规格：

Specification of cable:

| 项 目 Item | 单 位 NO | 材 质 及 尺 寸 Materials and size |
|--------------------------|--------------------|--|
| 内 导 体 Inner conductor | 材 质 Material | / 镀银铜线 Silver plated copper wire |
| | 构 成 Composition | mm 7/0.102±0.003 |
| | 外 径 OD | mm Φ0.30 |
| 绝 缘 Insulation | 材 质 Material | / Teflon PTFE (250 度聚四氟乙烯) Teflon PTFE (250 degree PTFE) |
| | 厚 度 Thickness | mm 0.275 |
| | 外 径 OD | mm Φ0.90±0.05 |
| 外 导 体 Outer conductor | 材 质 Material | / 镀锡铜线 Tinned copper wire |
| | 形 式 Form | / 编 织 Weave |
| | 密 度 Density | % 92%(22 目 (Mesh); 48 编 (Coding 3*16/0.10) |
| | 外 径 OD | mm Φ1.25±0.05 |
| 护 套 Jacket | 材 质 Material | / Teflon FEP (200 度 聚全氟乙烯-丙烯树脂) Teflon FEP (200 degrees of fluorinated |

| | | | |
|--|-------------------------|----|--|
| | | | ethylene propylene resin) |
| | 厚度 Thickness | mm | 0.275 |
| | 外径 OD | mm | $\Phi 1.80 \pm 0.08$ |
| | 护套颜色 color of sheath | / | 透明色或棕透明色(也可按客户要求加工) ransparent color or brown transparent color (Can also be processed according to customer requirements) |

3. 电缆特性

The cable properties

3.1 电气性能

Electrical properties

| 测试项目 test project | 标准要求 Standard value | | 备注 Note |
|---|------------------------|-----------------------------|---|
| 额定温度/电压 Rated temperature / voltage | -55℃~+200℃ / 30V | | / |
| 绝缘电阻 Insulation resistance | 3000M Ω . Km | | 电阻测试仪 Resistance tester |
| 导体电阻 Conductor resistance | 345 Ω /Km 20℃ | | / |
| 耐压 Pressure | 2KV | | 耐压测试仪 Withstand voltage tester |
| 绝缘 Insulation | 未老化前 Unaged | 抗拉强度 Tensile Strength | 2500 PSI MIN. (1.76Kg/mm ²) |
| | | 延伸率 Elongation | 200% MIN |
| | 老化后 Aged | 抗拉强度 Tensile Strength | 2500 PSI*75% (168HRS*232℃) |
| | | 延伸率 Elongation | 200% MIN*75% (168HRS*232℃) |
| 护套 Jacket | 未老化前 Unaged | 抗拉强度 Tensile Strength | 2500 PSI MIN. (1.76Kg/mm ²) |
| | | 延伸率 Elongation | 200% MIN |
| | 老化后 Aged | 抗拉强度 Tensile Strength | 2500 PSI*75% (168HRS*232℃) |
| | | 延伸率 Elongation | 200% MIN*75% (168HRS*232℃) |
| 特性阻抗 characteristic impedance | 50 \pm 2 Ω | | 网析分析仪、TRK 测试仪 Analysis of network analyzer The TRK tester |
| 电容 Capacitance | 95.8 PF/M | | 数字电容仪 Digital capacitance meter |
| 传输速率 Velocity | 69.5% | | 网析分析仪 Analysis of network analyzer |

| | | | |
|-----------------------------------|------------------------|-------------------|--|
| 传输延迟 Propagation Delay | 4. 8ns/m | | / |
| 屏蔽率减 Shielding attenuation | 100dB | | / |
| 弯曲半径 Bending radius | <9mm | | / |
| 阻燃性 (UL) Flame retardant | passed | | VW-1 提供材料报告 VW-1 provides material report |
| 屏蔽衰减 (dB/m) Attenuation (dB/m) | 测试频率 test frequency | 衰减 Attenuation | 海平面 20℃测试 Sea level to 20 DEG C test |
| | 0. 1GHz | 0. 46 | |
| | 0. 4GHz | 0. 95 | |
| | 1GHz | 1. 48 | |
| | 2GHz | 2. 65 | |
| | 3GHz | 3. 28 | |
| | 4GHz | 3. 54 | |
| | 5GHz | 4. 30 | |
| | 6GHz | 4. 80 | |
| 驻波比 VSWR | 0. 3—3GHz | ≤1. 30 | |
| | 3—6GHz | ≤1. 35 | |

4. 包装要求

Packaging requirements

4.1 包装长度: 500 米

Package length: 500 meters

包装方式: 轴,

The way of packing: Volume

最短线长度: ≥50 米

The stub length: ≥50 meters

4.2 包装标识: 标准或按客户要求.

Packaging and labeling: standard or according to customer requirements.

5. Material Safety Data Sheet (物质安全资料表)

**物品与厂商资料

物品名称: 同轴高频线

物品编号: RG178 TC 系列

**成分辨识资料

纯物质:

中英文名称: 氟树脂 Teflon/镀银线 Silver Plated Copper/镀锡铜线 Tinned Plated Copper 同义名称: FEP/SC/

化学文摘社登记号码 (CAS No.):

危害物质成分 (成分百分比):

- 混合物: 8108mg/km

| NO | 部件名称 | 所在 | 重量 (mg) | 材质成份 | 组成成份 | 重量 (mg) | 材质成份 | 化学号 CAS NO |
|----|------|----|---------|------|------|---------|------|------------|
|----|------|----|---------|------|------|---------|------|------------|

*****此智慧财产权属于深圳市海联通科技有限公司, 未经允许严禁拷贝*****

| | | 部位 | | | | 占比(%) | | |
|---|-------|-----|------|---------------------------|---------------------------|---------|-------|---|
| 1 | RG178 | 导体 | 509 | Silver Jackted Wire | Cu | 492 | 96.66 | 7440-50-8 |
| 2 | | | | | Ag | 11.92 | 2.34 | 7440-22-4 |
| 3 | | | | | Sb./Fe./PB/SE/AS./AG/BI/S | 5.08 | 1.00 | 7440-36-0/7439-89-6/7439-92-1/7782-49-2/0744-38-2/7440-22-4/ 7440-69-9 |
| 4 | | 绝缘 | 1160 | Teflon | Teflon | 116.00 | 100 | 9002-84-0/25067-11-2 |
| 5 | | 外导体 | 3800 | Tinned wire | CU | 3673.08 | 96.66 | 7440-50-8 |
| 6 | | | | | Sn | 88.92 | 2.34 | 7440-31-5 |
| 7 | | | | | Sb./Fe./PB/SE/AS./AG/BI/S | 38.00 | 1.00 | 7440-36-0/7439-89-6/7439-92-1/7782-49-2/0744-38-2/7440-22-4/ 7440-69-9 |
| 8 | | 护套 | 2640 | Teflon | FEP | 2638.94 | | 25067-11-2 |
| 9 | | | | 棕色色母 | | 1.056 | | 8062-14-4 |

● 化学性质:

| 有害物质成分之中英文名称 | 浓度或浓度范围(成分百分比) | 有害物质分类及图式 |
|--|----------------|-----------|
| 铅及其化合物(Pb)Lead and Lead compound | ≤90PPM | |
| 镉及其化合物(Cd)Cadmium and Cadmium compound | ≤75PPM | |
| 汞及其化合物(Hg)Mercury and Mercury compound | ≤1000PPM | |
| 六价铬及其化合物(Cr ⁺⁶)Hexvalent Chromium compound | ≤1000PPM | |
| 溴(Br)Bromine | ≤900PPM | |
| 氯(Cl)Chlorine | ≤900PPM | |
| 溴+氯(Br+Cl) Bromine and Chlorine | ≤1500PPM | |
| 全氟辛烷硫磺酸(PFOS) | ≤1000PPM | |
| 四溴双酚 A (TBBPA) | ≤1000PPM | |
| 六溴环十二烷(HBCDD) | ≤1000PPM | |
| 其他限用物资等 | 禁止使用 | |

● 危害辨识数据

| | |
|---------------------|--|
| 最 重 要 危 害 效 应 | 健康危害效应: 在 260℃ 以上, 可能会有吸入分解气体的危险. 一定要安装排气装置. |
| | 环境影响: 要按废弃物处理及清扫法律法规处理, 绝对不可燃烧. |
| | 物理性及化学性危害: 物理化学性能极其稳定, 不易降解, 不得擅自填埋. |
| | 特殊危害: 无 |
| 主要症状: 对人的神经系统产生损害 | |
| 物品危害分类: 大气和水源 | |

● 急救措施

| |
|-----------------|
| 不同暴露途径之急救方法: |
| · 吸入: 到空气流通处换气. |
| · 皮肤接触: 无 |
| · 眼睛接触: 无 |
| · 食入: 不消化, 排出. |
| 最重要症状及危害效应: |
| 对急救人员之防护: 对流换气 |
| 对医师之提示: 吸氧 |

● 灭火措施

| |
|-----------|
| 适用灭火剂: 通用 |
|-----------|

| |
|------------------------|
| 灭火时可能遭遇之特殊危害： 避免分解气体吸入 |
| 特殊灭火程序： 无 |
| 消防人员之特殊防护设备： 防毒面罩 |

● 泄漏处理方法

| |
|---------------------------------|
| 个人应注意事项： 粉状或粒状树脂 |
| 环境注意事项： 不可填埋 |
| 清理方法： 要按废弃物处理及清扫法律法规处理, 绝对不可燃烧. |

● 安全处置与储存方法

| |
|-----------------|
| 处置： 避免与高温和火源接触. |
| 储存： 通风干燥处. |

● 暴露预防措施

| |
|---|
| 工程控制： |
| 控制参数： · 八小时日时量平均容许浓度/短时间时量平均容许浓度/最高容许浓度： · 生物指标： |
| 个人防护设备： · 呼吸防护： 安装排气装置 · 手部防护： 无 · 眼睛防护： 无 · 皮肤及身体防护： 无 |
| 卫生措施： 应将衣服上附着的灰尘抖落, 手脸洗净, 不要让其附着于香烟上. |

● 物理及化学性质

| | |
|-------------|---------------------------|
| 物质状态： 固体 | 形状： 透明颗粒 |
| 颜色： 透明或客户要求 | 气味： 无 |
| pH 值： 7 | 沸点/沸点范围： / |
| 分解温度： 427℃ | 闪火点： °F °C 测试方法： 开杯 闭杯 |
| 自燃温度： / | 爆炸界限： / |
| 蒸气压： / | 蒸气密度： / |
| 密度： 2.2 | 溶解度： / |

● 安定性及反应性

| |
|------------------------------------|
| 安定性： 很稳定 |
| 特殊状况下可能之危害反应： 高温或燃烧分解气体对人体神经系统的损害. |
| 应避免之状况： 绝对不可燃烧. |
| 应避免之物质： 金属钠及其强酸的混合物 . |
| 危害分解物： 气体及粉尘. |

● 毒性资料

| |
|-------------|
| 急毒性： / |
| 局部效应： / |
| 致敏感性： / |
| 慢毒性或长期毒性： / |

| |
|---------|
| 特殊效应: / |
|---------|

- 生态资料

| |
|----------------------|
| 可能的环境影响: 不降解, 禁填埋 |
|----------------------|

- 废弃处置方法

| |
|--|
| 废弃处置方法: 按废弃物处理及清扫法律法规要求送专业资质处理公司处置. |
|--|

- 运送资料

| |
|---------|
| 国际运送规定: |
|---------|

| |
|---|
| / |
|---|

| |
|----------|
| 联合国编号: / |
|----------|

| |
|-----------|
| 国内运送规定: 无 |
|-----------|

| |
|----------------|
| 特殊运送方法及注意事项: 无 |
|----------------|

- 法规资料

| |
|-------|
| 适用法规: |
|-------|

- 其它数据

| | |
|------|--------------------|
| 参考文献 | 杜邦产品说明/ROHS 限用物资标准 |
|------|--------------------|

我司产品执行 UL-1979 标准, 暂不提供 UL 标准认证号, 可提供 SGS、MSDM 报告。

Our products are the implementation of UL-1979 standard, does not provide UL certification standards, can provide SGS, MSDM report.

此规格书只适用于常规线材, 若客户所需线材为特殊规格的, 请以线材承认书为准。

This specification is only for conventional wire, if the customer needed to wire for special specification, please refer to our wire admitted that book.

九、塑胶物性表

ABS:



CHI MEI CORPORATION

59-1 SAN CHIA, JEN TE, TAINAN COUNTY, TAIWAN R.O.C. TEL: 886-6-266-5000, FAX: 886-6-266-5555-7

泛用級 ABS, POLYLAC® PA-757

VIW

材料特性

| 特性(Properties) | 測試方法(Test Method) | 測試條件(Test Condition) | 單位(Unit) | PA-757 |
|--|--------------------|--------------------------|--|--------------------|
| 引張強度 Tensile Strength | ASTM D638 | 1/8", 6 mm/min | Kg/cm ² (lb/in ²) | 480(6800) |
| 延伸率 Tensile Elongation | ASTM D638 | 1/8", 6 mm/min | % | 20 |
| 彎曲強度 Flexural Strength | ASTM D790 | 1/4", 2.8 mm/min | Kg/cm ² (lb/in ²) | 820(11660) |
| 彎曲彈性率 Flexural Modulus | ASTM D790 | 1/4", 2.8 mm/min | Kg/cm ² (lb/in ²) | 27000(380000) |
| IZOD 衝擊強度 Izod Impact Strength | ASTM D256(Notched) | 1/4", 23°C 1/8", 23°C | Kg-cm/cm(ft-lb/in) Kg-cm/cm(ft-lb/in) | 18(3.3) 20(3.7) |
| 流動係數 Melt Flow Index | ASTM D1238 | 200°C, 5Kg | g/10min | 1.8 |
| 硬度 Hardness | ASTM D785 | 1/2" | R Scale | 116 |
| 比重 Specific Gravity | ASTM D792 | 23°C | - | 1.05 |
| 軟化點 Vicat Softening Temp | ASTM D1525 | 1/8", 50°C/hr | °C(°F) | 105(221) |
| 熱變形溫度 H.D.T Annealed(85°C, 8hr) Unannealed | ASTM D648 | 1/4", 120°C/hr | °C(°F) | 99(210) 88(190) |
| 燃燒率 Flammability | UL 94 | - | - | 1/16"HB |

以上數據僅代表一般通用數據，不代表每一產品的規格值

若有任何疑問請洽產品推廣課 06-2665000, 06-2663000

新光合成纖維股份有限公司
中壢廠
臺灣

8th Fl., 123, Sec.2, Nanking East Road, Taipei, Taiwan
Tel: 886-2-2507-0131 886-2-2507-1251(30Lines) 886-3-4932131
Fax:886-2-2506-8047 886-3-491-5763

產品材質證明

新耐特 (SHINITE) PC/PBT

規格(GRADE)：A724

新耐特 (SHINITE) PC/PBT 為新光合成纖維股份有限公司，所產製的工程塑膠系列之一，經由混練程序製得。具有優越的機械性、高剛性、尺寸安定性、耐熱老化性和化學性質。

此外新耐特 (SHINITE) PC/PBT A724

製品 組成如下：

| 組成 CHEMICAL NAME | GRADE 規格 | A724 |
|---|-------------|---------|
| polycarbonate (PC) 樹脂 CAS NO: 25971-63-5 | | 40%~80% |
| Polybutylene Terephthalate (PBT) 樹脂 CAS NO: 26062-94-2 | | 20%~60% |
| Additives 添加劑 CAS NO: N.A. | | 1%~10% |

GREEN PRODUCT (無毒材料) 符合 RoHS 、REACH(SVHC)

如有任何的問題及意見，歡迎撥空指教，謝謝。



送出日期:October 13, 2011

PTFE棒材质证明（物性表）

| 序号 | 材质项目 | 物理特性 | 备注 |
|----|-----------|--------------------------|------|
| 1 | 名称 | 聚四氟乙烯 | PTFE |
| 2 | 密度 | 2.1~2.3G/cm ³ | |
| 3 | 吸水率 | ≤0.00001% | |
| 4 | 拉伸强度 | ≥15Mpa | |
| 5 | 断裂伸长率 | ≥150% | |
| 6 | 硬度 | 50~60 | |
| 7 | 弯曲强度 | 20.4~21Mpa | |
| 8 | 压缩强度 | 11.2~13.8 | |
| 9 | 绝缘强度 | 18.5~21KV/mm | |
| 10 | 使用温度 | -196℃~+260℃ | |
| 11 | 介电常数 | 1.85~2.3 | |
| 12 | 介质损耗 | ∠0.0002 | |
| 13 | 表面电阻 | > 10E16欧姆 | |
| 14 | 体积电阻 | > 10E16欧姆 | |
| 15 | 收缩率（-70℃） | 0.75% | |
| 16 | 熔点 | 327±10 | |
| 17 | 导热率 | 0.02KCAL/M.H.C | |

检测日期：2014年03月03日

汕头市新阳金属制品实业有限公司

| | | | | | | | | | | | | | |
|------|-------------------------|--------|--------|----------------------|--------|-----------|------------------|--------|---------|----------|---------------|-------|--------|
| 客户名称 | | | | | 订单 | | | | | 出货日期 | | | |
| 国标标准 | GB/T4423-2007 | | | | 试材品名 | C3604环保铜枝 | | | | 试材规格 | | | |
| 仪器名称 | 德国WAS发射光谱分析仪 | | | | 化学试验 | 生产日期 | | | | 炉火 批次 | 20100530C3611 | | |
| 元素名称 | 铜 (Cu) | 锌 (Zn) | 铅 (Pb) | 铝 (Al) | 锰 (Mn) | 锡 (Sn) | 铁 (Fe) | 硅 (Si) | 锑 (Sb) | 镉 (Cd) | 铋 (Bi) | 磷 (P) | 镍 (Ni) |
| 标准含量 | 58-59 | 余量 | ≤2.95 | ≤0.1 | ≤0.01 | ≤0.5 | ≤0.6 | ≤0.1 | ≤0.07 | ≤0.005 | ≤0.007 | ≤0.19 | ≤0.12 |
| 试片含量 | 58.3 | 余量 | 2 | 0.002 | 0.002 | 0.411 | 0.308 | 0.005 | 0.0172 | 0.0033 | 0.0781 | 0.003 | 0.113 |
| 机械试验 | Mechanical Testing | | | | | | | | | | | | |
| 仪器名称 | WD-50B电子式万能试验 | | | | | | | | | | | | |
| 物理性质 | 抗拉强度 (Tensile Strength) | | | | | | 延伸率 (Elongation) | | | | 硬度 (Hardness) | | |
| 实际数值 | 40-60 | | | [N/mm ²] | | | 10 | | &10≥[%] | | 160 | HV | |
| 单位主管 | 黄晓辉 | | | | | | | | 分析员 | | 吴育盛 | | |

Duracon® M90-44

聚甲醛 (POM) 共聚物
Polyplastics Co., Ltd.



ides.com/prospector

Technical Data

产品说明

Standard, Standard
Color No.: CF2001/CD3068

总体

| | |
|--------------------|---|
| 材料状态 | • 已商用 : 当前有效 |
| 资料 ¹ | • Processing - Molding (English) • Processing - Troubleshooting Guide (English) • Technical Datasheet - ASTM (English) • Technical Datasheet - ISO (English) |
| UL 黄卡 ² | • E45034-100337529 • E45034-235766 |
| 搜索 UL 黄卡 | • Polyplastics Co., Ltd. • Duracon® |
| 供货地区 | • 北美洲 • 欧洲 • 亚太地区 |
| UL 档案号 | • E45034 • E45034 |
| 部件标识代码 (ISO 11469) | • >POM< |

| 物理性能 | 额定值 | 单位制 | 测试方法 |
|-------------------|------------------------|-----|-----------------------|
| 比重 | 1.41 g/cm ³ | | ASTM D792 ISO 1183 |
| 吸水率 (23°C, 24 hr) | 0.50 % | | ISO 62 |

| 机械性能 | 额定值 | 单位制 | 测试方法 |
|------------------------------------|----------|-----|-----------|
| 抗张强度 | 60.0 MPa | | ASTM D638 |
| -- | 62.0 MPa | | ISO 527-2 |
| 伸长率 | 60 % | | ASTM D638 |
| 断裂 | 35 % | | ISO 527-2 |
| 断裂 | | | |
| 弯曲模量 | 2580 MPa | | ASTM D790 |
| -- | 2500 MPa | | ISO 178 |
| 弯曲强度 | 90.0 MPa | | ASTM D790 |
| -- | 87.0 MPa | | ISO 178 |
| 摩擦系数 | | | JIS K7218 |
| vs. Unknown - Dynamic ⁴ | 0.37 | | |
| 与钢 - 动态 ⁵ | 0.46 | | |
| 与钢 - 动态 ⁶ | 0.40 | | |

| 冲击性能 | 额定值 | 单位制 | 测试方法 |
|-----------|-----------------------|-----|-------------|
| 简支梁缺口冲击强度 | 6.0 kJ/m ² | | ISO 179/1eA |
| 悬臂梁缺口冲击强度 | 63 J/m | | ASTM D256 |
| 反向缺口冲击 | 760 J/m | | ASTM D256 |

| 热性能 | 额定值 | 单位制 | 测试方法 |
|-----------------|------------------|-----|-------------|
| 热变形温度 | | | |
| 1.8 MPa, 未退火 | 110 °C | | ASTM D648 |
| 1.8 MPa, 未退火 | 95.0 °C | | ISO 75-2/A |
| 线形膨胀系数 | | | |
| 流动 ⁷ | 0.00010 cm/cm/°C | | ASTM D696 |
| 流动: 23 到 55°C | 0.00012 cm/cm/°C | | No Standard |
| 横向 ⁷ | 0.00010 cm/cm/°C | | ASTM D696 |
| 横向: 23 到 55°C | 0.00012 cm/cm/°C | | No Standard |

1 / 3

UL and the UL logo are trademarks of UL LLC © 2013. All Rights Reserved.
UL IDES | 800-788-4668 or 307-742-9227 | www.ides.com

文件号 : TDS-83327-zh

文件建立日期 : 2013年6月19日
添加到 Prospector : 2005年4月
上次更新 : 2012/12/4

此数据表中的信息由 UL IDES 从该材料的生产商处获得。UL IDES 尽最大努力确保此数据的准确性。但是 UL IDES 对这些数据值不承担任何责任, 并强烈建议在最终选择材料前, 就数据值与材料供应商进行验证。

| 电气性能 | 额定值 单位制 | 测试方法 |
|----------------------|---|-------------|
| 表面电阻率 | 1.0E+16 ohm | IEC 60093 |
| 体积电阻率 | | |
| 3.00 mm | 1.0E+14 ohm·cm | ASTM D257 |
| -- | 1.0E+14 ohm·cm | IEC 60093 |
| 介电强度 | | |
| 2.00 mm ⁸ | 24 kV/mm | ASTM D149 |
| 3.00 mm | 19 kV/mm | IEC 60243-1 |
| 可燃性 | 额定值 单位制 | 测试方法 |
| UL 阻燃等级 | HB | UL 94 |
| 补充信息 | 额定值 单位制 | 测试方法 |
| Specific Wear | | JIS K7218 |
| -- ⁹ | < 0.0100 10 ⁻³ mm ³ /N·km | |
| -- ¹⁰ | < 0.0100 10 ⁻³ mm ³ /N·km | |
| -- ¹¹ | 65.0 10 ⁻³ mm ³ /N·km | |
| -- ¹² | 35.0 10 ⁻³ mm ³ /N·km | |
| -- ¹³ | 0.650 10 ⁻³ mm ³ /N·km | |
| -- ¹⁴ | 0.300 10 ⁻³ mm ³ /N·km | |

备注

¹ 通过这些链接您能够访问供应商资料。我们尽量保证及时更新资料；不过您可以从供应商处了解最新资料。

² UL 黄卡含有 UL 验证的易燃性和电气特性。UL IDES 持续努力在 Prospector 中将黄卡链接至单个塑料材料，然而此列表可能未包括所有相应链接。重要的是，我们对 Prospector 中找到的这些黄卡和塑料材料之间的关联进行验证。如需完整的黄卡列表，请访问 UL 黄卡搜索。

³ 一般属性：这些不能被视为规格。

⁴ vs. M90-44; Pressure 0.06MPa, 15cm/s

⁵ Pressure 0.49MPa, 30cm/s

⁶ Pressure 0.98MPa, 30cm/s

⁷ @ Room Temperature

⁸ Short-time test

⁹ vs. C-Steel, Steel Side, Pressure 0.49 MPa, 30 cm/s

¹⁰ vs. C_Steel, steel side, pressure 0.98MPa, 30cm/s

¹¹ vs. M90-44, M90-44 side, pressure 0.06MPa, 15cm/s

¹² vs. M90-44, material side, pressure 0.06MPa, 15cm/s

¹³ vs. C_Steel, material side, pressure 0.49MPa, 30cm/s

¹⁴ vs. C_Steel, material side, pressure 0.98MPa, 30cm/s

Duracon® M90-44

聚甲醛 (POM) 共聚物

Polyplastics Co., Ltd.

购买地点

供应商

Polyplastics Co., Ltd.

Tokyo, Japan

电话: (81)3-3593-2441

Web: <http://www.polyplastics.com/>

分销商

请联系供应商以便为 Duracon® M90-44 查找分销商

| 客戶 | | WNC | | 料號 | RF21S00940A | | | | 複數/穴數 | / | | | 機種 | / | | |
|---------------------|--------------------|--------------------|--------------|--------------------|-------------|---------------|-------------|---------------------|---------------|---------------|--------------|--------------|--------------|----------|----|--------|
| 圖面版次 | | 1 | | 品名 | SMA 外置天线 | | | | 單位 | mm/deg. | | | 量測日期 | 2020.7.1 | | |
| Item | Key Dim. (* / Cpk) | Measure Instrument | Drawing Dim. | | | Control Limit | | Actual Dim. 1 | Actual Dim. 2 | Actual Dim. 3 | Delta Dim. 1 | Delta Dim. 2 | Delta Dim. 3 | Result | | Remark |
| | | | Nominal | Tolerance | | Lower limit | Upper limit | | | | | | | OK | NG | |
| | | | | - | + | | | | | | | | | | | |
| 1 | | 数显卡尺 | 137.00 | -3 | 3 | 134.000 | 140.000 | 137.360 | 137.330 | 137.340 | 0.360 | 0.330 | 0.340 | * | | |
| 2 | | 数显卡尺 | 116.00 | -3 | 3 | 113.000 | 119.000 | 116.200 | 116.170 | 116.140 | 0.200 | 0.170 | 0.140 | * | | |
| 3 | | 数显卡尺 | 36.50 | -1 | 1 | 35.500 | 37.500 | 36.410 | 36.370 | 36.410 | -0.090 | -0.130 | -0.090 | * | | |
| 4 | | 数显卡尺 | 9.35 | -0.1 | 0.1 | 9.250 | 9.450 | 9.330 | 9.360 | 9.350 | -0.020 | 0.010 | 0.000 | * | | |
| 5 | | 数显卡尺 | 19.50 | -1 | 1 | 18.500 | 20.500 | 19.520 | 19.550 | 19.510 | 0.020 | 0.050 | 0.010 | * | | |
| 6 | | 数显卡尺 | 10.00 | -1 | 1 | 9.000 | 11.000 | 9.560 | 9.520 | 9.510 | -0.440 | -0.480 | -0.490 | * | | |
| 7 | | 二次元 | 110.00 | -3 | 3 | 107.000 | 113.000 | 110.370 | 110.350 | 110.410 | 0.370 | 0.350 | 0.410 | * | | |
| 8 | | | | | | 0.000 | 0.000 | | | | | | | * | | |
| 9 | | | | | | 0.000 | 0.000 | | | | | | | * | | |
| 10 | | | | | | 0.000 | 0.000 | | | | | | | * | | |
| 11 | | | | | | 0.000 | 0.000 | | | | | | | * | | |
| 12 | | | | | | 0.000 | 0.000 | | | | | | | * | | |
| 13 | | | | | | 0.000 | 0.000 | | | | | | | * | | |
| 14 | | | | | | 0.000 | 0.000 | | | | | | | * | | |
| 15 | | | | | | 0.000 | 0.000 | | | | | | | * | | |
| 16 | | | | | | 0.000 | 0.000 | | | | | | | * | | |
| 17 | | | | | | 0.000 | 0.000 | | | | | | | * | | |
| 18 | | | | | | 0.000 | 0.000 | | | | | | | * | | |
| 19 | | | | | | 0.000 | 0.000 | | | | | | | * | | |
| 20 | | | | | | 0.000 | 0.000 | | | | | | | * | | |
| 21 | | | | | | 0.000 | 0.000 | | | | | | | * | | |
| 22 | | | | | | 0.000 | 0.000 | | | | | | | * | | |
| 23 | | | | | | 0.000 | 0.000 | | | | | | | * | | |
| 24 | | | | | | 0.000 | 0.000 | | | | | | | * | | |
| 25 | | | | | | 0.000 | 0.000 | | | | | | | * | | |
| 26 | | | | | | 0.000 | 0.000 | | | | | | | * | | |
| 27 | | | | | | 0.000 | 0.000 | | | | | | | * | | |
| 28 | | | | | | 0.000 | 0.000 | | | | | | | * | | |
| 29 | | | | | | 0.000 | 0.000 | | | | | | | * | | |
| 30 | | | | | | 0.000 | 0.000 | | | | | | | * | | |
| 31 | | | | | | 0.000 | 0.000 | | | | | | | * | | |
| 32 | | | | | | 0.000 | 0.000 | | | | | | | * | | |
| 33 | | | | | | 0.000 | 0.000 | | | | | | | * | | |
| 34 | | | | | | 0.000 | 0.000 | | | | | | | * | | |
| 35 | | | | | | 0.000 | 0.000 | | | | | | | * | | |
| 36 | | | | | | 0.000 | 0.000 | | | | | | | * | | |
| 37 | | | | | | 0.000 | 0.000 | | | | | | | * | | |
| 38 | | | | | | 0.000 | 0.000 | | | | | | | * | | |
| 39 | | | | | | 0.000 | 0.000 | | | | | | | * | | |
| 40 | | | | | | 0.000 | 0.000 | | | | | | | * | | |
| 41 | | | | | | 0.000 | 0.000 | | | | | | | * | | |
| 42 | | | | | | 0.000 | 0.000 | | | | | | | * | | |
| 43 | | | | | | 0.000 | 0.000 | | | | | | | * | | |
| 44 | | | | | | 0.000 | 0.000 | | | | | | | * | | |
| 45 | | | | | | 0.000 | 0.000 | | | | | | | * | | |
| 46 | | | | | | 0.000 | 0.000 | | | | | | | * | | |
| 47 | | | | | | 0.000 | 0.000 | | | | | | | * | | |
| 48 | | | | | | 0.000 | 0.000 | | | | | | | * | | |
| 49 | | | | | | 0.000 | 0.000 | | | | | | | * | | |
| 50 | | | | | | 0.000 | 0.000 | | | | | | | * | | |
| 51 | | | | | | 0.000 | 0.000 | | | | | | | * | | |
| 52 | | | | | | 0.000 | 0.000 | | | | | | | * | | |
| 53 | | | | | | 0.000 | 0.000 | | | | | | | * | | |
| 54 | | | | | | 0.000 | 0.000 | | | | | | | * | | |
| 55 | | | | | | 0.000 | 0.000 | | | | | | | * | | |
| 56 | | | | | | 0.000 | 0.000 | | | | | | | * | | |
| 57 | | | | | | 0.000 | 0.000 | | | | | | | * | | |
| 58 | | | | | | 0.000 | 0.000 | | | | | | | * | | |
| COMMENTS | | | | | | | | | | | | | | | | |
| Measured by: | | | | Checked By: | | | | Approved by: | | | | | | | | |

| 客戶 | WNC | 機種 | / | | | 料號 | RF21.S00940A | | 品名 | SMA 外置天线 | | | | |
|----------------------|-----|-------------|-------------|-------------|-------------|-------------|--------------|-------------|-------------|-------------|--------------|--------------|--------------|--|
| 模數-穴數 | / | 圖面版次 | 1 | | | 單位 | mm/deg. | | 量測日期 | 2020.7.1 | | | | |
| | | Dimension 1 | Dimension 2 | Dimension 3 | Dimension 4 | Dimension 5 | Dimension 6 | Dimension 7 | Dimension 8 | Dimension 9 | Dimension 10 | Dimension 11 | Dimension 12 | |
| 尺寸標準(SPEC) | | 137.00 | 110.00 | 116.00 | 9.35 | 36.50 | 19.50 | 10.00 | | | | | | |
| 正公差 | | 3.00 | 3.00 | 3.00 | 0.10 | 1.00 | 1.00 | 1.00 | | | | | | |
| 負公差 | | -3.00 | -3.00 | -3.00 | -0.10 | -1.00 | -1.00 | -1.00 | | | | | | |
| 圖面規格上限 | | 140.000 | 113.000 | 119.000 | 9.450 | 37.500 | 20.500 | 11.000 | 0.000 | 0.000 | 0.000 | 0.000 | 0.000 | |
| 圖面規格下限 | | 134.000 | 107.000 | 113.000 | 9.250 | 35.500 | 18.500 | 9.000 | 0.000 | 0.000 | 0.000 | 0.000 | 0.000 | |
| 承認規格上限 (70% 公差區間) | | 139.100 | 112.100 | 118.100 | 9.420 | 37.200 | 20.200 | 10.700 | 0.000 | 0.000 | 0.000 | 0.000 | 0.000 | |
| 承認規格下限 (70% 公差區間) | | 134.900 | 107.900 | 113.900 | 9.280 | 35.800 | 18.800 | 9.300 | 0.000 | 0.000 | 0.000 | 0.000 | 0.000 | |
| 1 | | 137.33 | 110.56 | 115.96 | 9.31 | 36.35 | 19.54 | 9.66 | | | | | | |
| 2 | | 137.38 | 110.51 | 116.12 | 9.35 | 36.30 | 19.52 | 9.56 | | | | | | |
| 3 | | 137.25 | 110.46 | 116.28 | 9.31 | 36.37 | 19.50 | 9.61 | | | | | | |
| 4 | | 137.29 | 110.38 | 115.98 | 9.30 | 36.41 | 19.55 | 9.54 | | | | | | |
| 5 | | 137.30 | 110.50 | 116.21 | 9.35 | 36.32 | 19.56 | 9.63 | | | | | | |
| 6 | | 137.21 | 110.39 | 116.10 | 9.34 | 36.45 | 19.52 | 9.57 | | | | | | |
| 7 | | 137.41 | 110.41 | 116.13 | 9.38 | 36.35 | 19.52 | 9.56 | | | | | | |
| 8 | | 137.45 | 110.37 | 116.17 | 9.33 | 36.36 | 19.60 | 9.61 | | | | | | |
| 9 | | 137.33 | 110.42 | 116.23 | 9.35 | 36.33 | 19.47 | 9.58 | | | | | | |
| 10 | | 137.22 | 110.37 | 116.15 | 9.36 | 36.43 | 19.19 | 9.66 | | | | | | |
| 11 | | 137.26 | 110.50 | 116.19 | 9.35 | 36.38 | 19.52 | 9.55 | | | | | | |
| 12 | | 137.20 | 110.41 | 115.99 | 9.33 | 36.39 | 19.51 | 9.62 | | | | | | |
| 13 | | 137.15 | 110.35 | 116.05 | 9.37 | 36.42 | 19.48 | 9.64 | | | | | | |
| 14 | | 137.23 | 110.47 | 116.22 | 9.37 | 36.37 | 19.50 | 9.67 | | | | | | |
| 15 | | 137.24 | 110.52 | 116.26 | 9.32 | 36.31 | 19.53 | 9.60 | | | | | | |
| 16 | | 137.31 | 110.29 | 116.18 | 9.35 | 36.36 | 19.50 | 9.61 | | | | | | |
| 17 | | 137.31 | 110.34 | 115.89 | 9.33 | 36.34 | 19.56 | 9.56 | | | | | | |
| 18 | | 137.20 | 110.21 | 116.21 | 9.34 | 36.33 | 19.51 | 9.51 | | | | | | |
| 19 | | 137.16 | 110.47 | 116.09 | 9.33 | 36.36 | 19.48 | 9.61 | | | | | | |
| 20 | | 137.35 | 110.59 | 116.23 | 9.38 | 36.44 | 19.49 | 9.63 | | | | | | |
| 21 | | 137.43 | 110.61 | 116.15 | 9.37 | 36.39 | 19.51 | 9.52 | | | | | | |
| 22 | | 137.23 | 110.42 | 116.24 | 9.35 | 36.35 | 19.52 | 9.57 | | | | | | |
| 23 | | 137.20 | 110.43 | 116.22 | 9.32 | 36.41 | 19.50 | 9.55 | | | | | | |
| 24 | | 137.38 | 110.36 | 116.21 | 9.35 | 36.38 | 19.53 | 9.59 | | | | | | |
| 25 | | 137.29 | 110.28 | 116.30 | 9.38 | 36.35 | 19.54 | 9.62 | | | | | | |
| 26 | | 137.25 | 110.54 | 116.28 | 9.39 | 36.37 | 19.49 | 9.61 | | | | | | |
| 27 | | 137.20 | 110.28 | 116.15 | 9.36 | 36.33 | 19.50 | 9.60 | | | | | | |
| 28 | | 137.34 | 110.37 | 116.29 | 9.35 | 36.32 | 19.51 | 9.59 | | | | | | |
| 29 | | 137.23 | 110.51 | 116.20 | 9.34 | 36.37 | 19.46 | 9.63 | | | | | | |
| 30 | | 137.29 | 110.41 | 115.96 | 9.36 | 36.35 | 19.52 | 9.65 | | | | | | |
| Min | | 137.150 | 110.210 | 115.890 | 9.300 | 36.300 | 19.190 | 9.510 | #NUM! | #NUM! | #NUM! | #NUM! | #NUM! | |
| Q1(Lower Quartile) | | 137.223 | 110.370 | 116.105 | 9.330 | 36.343 | 19.500 | 9.563 | #NUM! | #NUM! | #NUM! | #NUM! | #NUM! | |
| Q2(Median) | | 137.275 | 110.415 | 116.185 | 9.350 | 36.360 | 19.510 | 9.605 | #NUM! | #NUM! | #NUM! | #NUM! | #NUM! | |
| Q3(First Quartile) | | 137.330 | 110.500 | 116.228 | 9.360 | 36.388 | 19.528 | 9.628 | #NUM! | #NUM! | #NUM! | #NUM! | #NUM! | |
| Max | | 137.450 | 110.610 | 116.300 | 9.390 | 36.450 | 19.600 | 9.670 | #NUM! | #NUM! | #NUM! | #NUM! | #NUM! | |
| 平均數 | | 137.281 | 110.424 | 116.155 | 9.347 | 36.366 | 19.504 | 9.597 | #DIV/0! | #DIV/0! | #DIV/0! | #DIV/0! | #DIV/0! | |
| 標準差 | | 0.079 | 0.096 | 0.109 | 0.023 | 0.038 | 0.066 | 0.042 | #DIV/0! | #DIV/0! | #DIV/0! | #DIV/0! | #DIV/0! | |
| Ca | | 0.094 | 0.141 | 0.052 | 0.027 | 0.134 | 0.004 | 0.403 | #DIV/0! | #DIV/0! | #DIV/0! | #DIV/0! | #DIV/0! | |
| Cp | | 12.658 | 10.373 | 9.156 | 1.466 | 8.687 | 5.046 | 8.009 | #DIV/0! | #DIV/0! | #DIV/0! | #DIV/0! | #DIV/0! | |
| Cpk | | 11.474 | 8.906 | 8.684 | 1.427 | 7.526 | 5.024 | 4.782 | #DIV/0! | #DIV/0! | #DIV/0! | #DIV/0! | #DIV/0! | |
| 箱型圖判定 | | OK | OK | OK | OK | OK | OK | OK | OK | OK | OK | OK | OK | |
| 綜合判定 (Cpk & Boxplot) | | OK | OK | OK | OK | OK | OK | OK | #DIV/0! | #DIV/0! | #DIV/0! | #DIV/0! | #DIV/0! | |

Measured by:

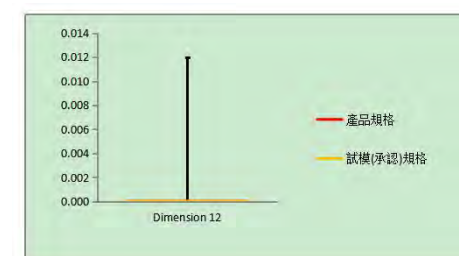
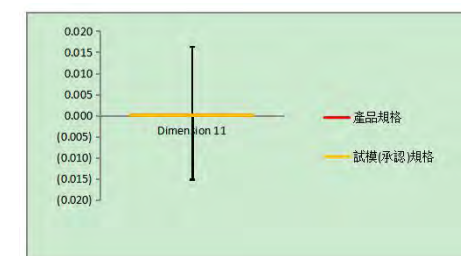
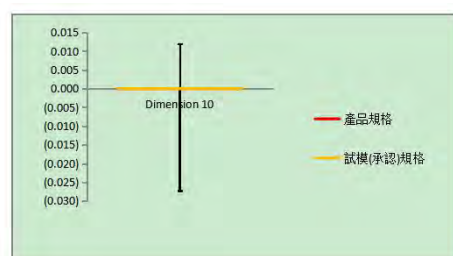
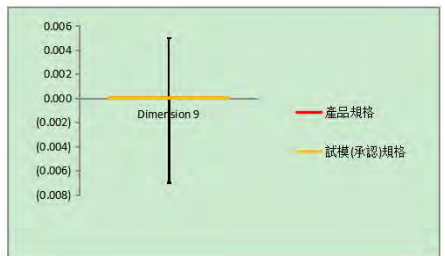
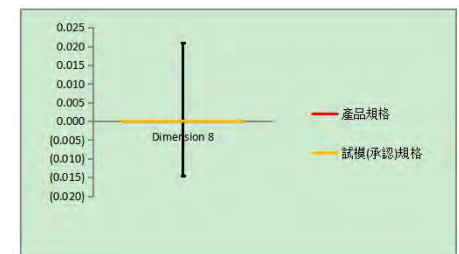
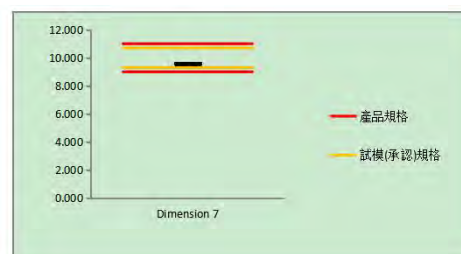
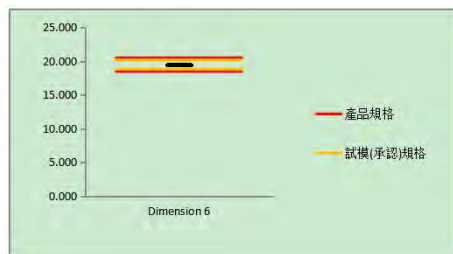
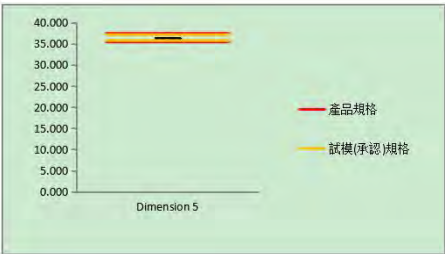
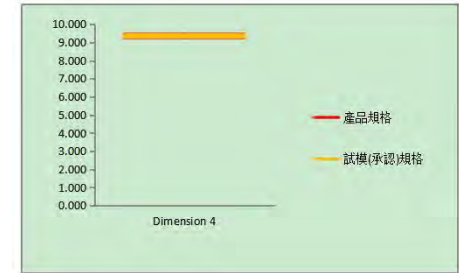
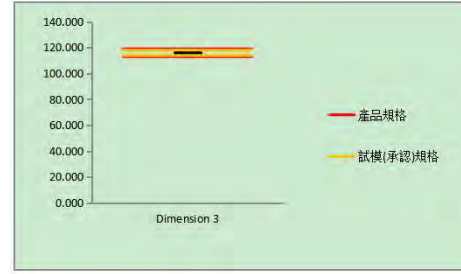
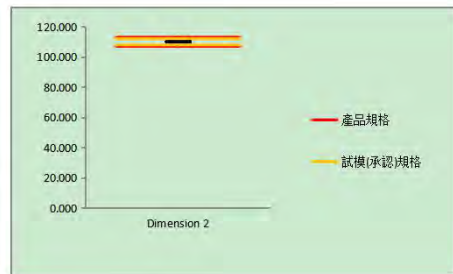
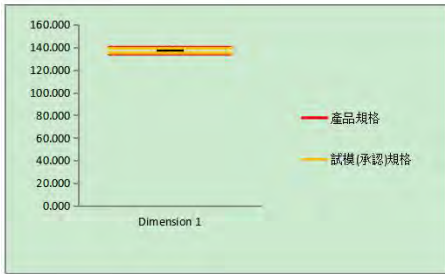

| | | | |
|-------------|--|--------------|--|
| COMMENTS | | | |
| Checked By: | | Approved by: | |

色差报告

Model: PART: CCI P/N: RF21C00940A杆套

| | | | | |
|--------------|-----------------------------------|---------|---------|-----------|
| 原料廠商 | 龙昌 | 原料材質 | ABS | 檢驗日期 |
| 色號 | 白色 | 原料編號 | / | 2020/7/14 |
| 測試報告 | | | | |
| 標準值 | L=99.65 a=0.4 b=-4.95 | | | |
| | △L±1.3 , △a±0.8 , △b±0.8 , △E 1.5 | | | |
| 配色色板值 | | | | |
| 客供色板值 | 1 | | | |
| L:99.97 | 99.97 | 99.97 | 99.97 | 99.97 |
| a : 0.58 | 0.58 | -0.58 | 0.58 | 0.58 |
| b : -5.39 | -5.93 | -5.39 | -5.39 | -5.39 |
| 对比值 | △E=0.51 | △E=0.76 | △E=0.71 | △E=0.71 |

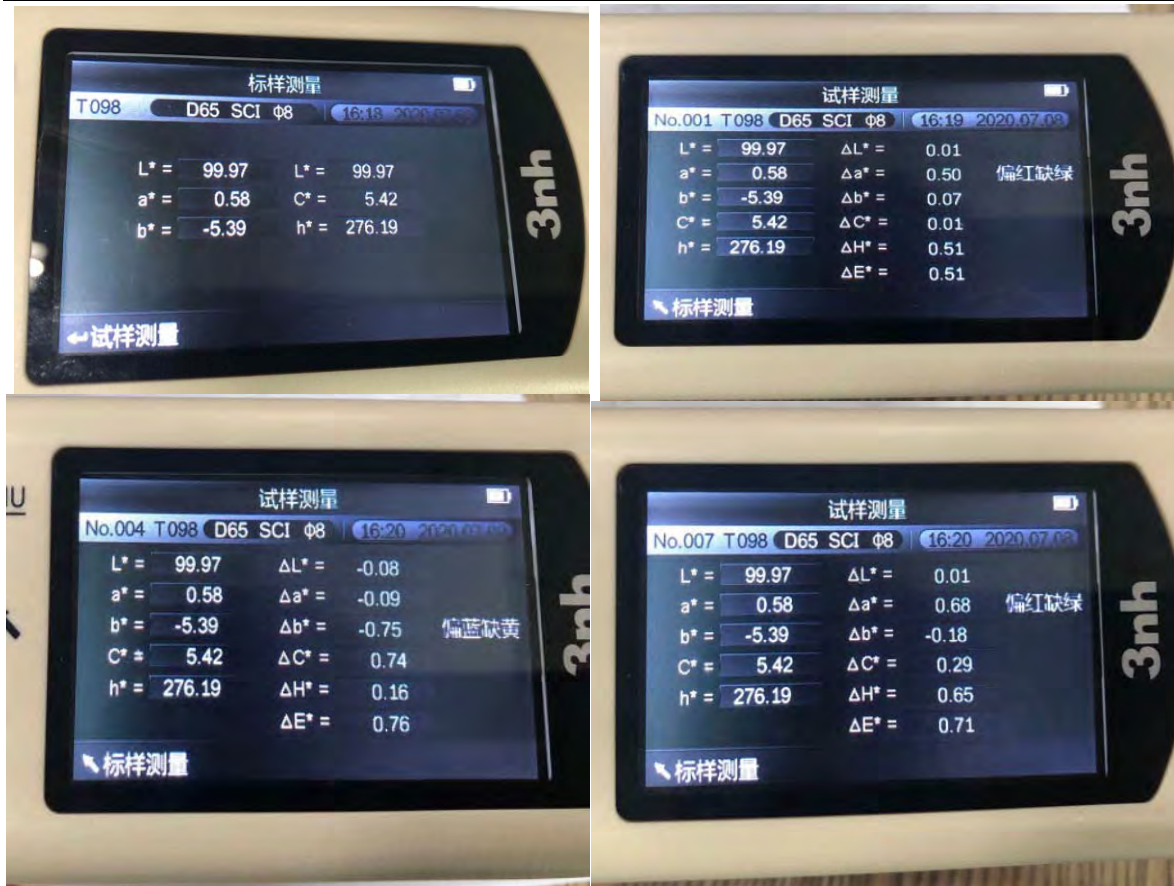

测试照片 (Test Photos) :



Step 1.产品外观检查图片 (Product appearance inspection picture) .



Step2.测试图片 (Test picture)



Step 3.产品外观检查图片 (Product appearance inspection picture) .

备注：高温70℃，湿度90Rh96小时后无变形以及其他异常，判OK。

~~ The End Of Test Report ~~

Approved : 龙爱云

Checked : 杨文华

Tester 肖芳芳

测试照片 (Test Photos) :



Step 1.产品外观检查图片 (Product appearance inspection picture).



| 程式组: 1 | | 循环次数: 0001 | | 当前程式保存 | | | | | | |
|--------|-------|------------|------|--------|-----|-----|-----|-----|-----|-----|
| 段号 | 00 | 01 | 02 | 03 | 04 | 05 | 06 | 07 | 08 | 09 |
| 温度 | -40.0 | -40.0 | 70.0 | 70.0 | 0.0 | 0.0 | 0.0 | 0.0 | 0.0 | 0.0 |
| 湿度 | 0 | 0 | 0 | 0 | 0 | 0 | 0 | 0 | 0 | 0 |
| 升降速度 | 1 | 1 | 1 | 1 | 0 | 0 | 0 | 0 | 0 | 0 |
| TS | OFF | OFF | OFF | OFF | OFF | OFF | OFF | OFF | OFF | OFF |

Step 2.测试图片 (Test picture)



Step 3.产品外观检查图片 (Product appearance inspection picture).

备注：高温70℃，低温-40℃72小时后无变形以及其他异常，判OK。

~ ~ The End Of Test Report ~ ~

Approved : 龙爱云

Checked : 杨文华

Tester 肖芳芳

Laboratory Test Report

盐雾试验报告 (Salt fog Test Report)

厂商/客户 (Manufacturer / customer) : 启基 生产日期 (Date of manufacture) : 2020/7/2

设备编号 (NO.): RF-YQ-027 测试日期 (Test date): 2020/7/3

品名 (Part Name) : 外置天线 规格 (Specifications) : 48H

料号 (Part No.) : RF21S00940A 盐雾浓度 (Salt fog concentration) : 5%

测试期间 (Testing Period) : 2020-6-21/8:00~2020-6-23/8:00

测试项目 (Test Description)

:

- 1.外观检查 (Check the appearance of the product)
- 2.盐雾测试 (Salt spray test)
- 3.外观检查 (Check the appearance of the product)

1.外观检查 (Check the appearance of the product)
目视无生锈或其他不良。
By visual inspection without noticeable rust.

2.盐雾测试 (Salt Spray Test Report)

试验应使用温度控制范围可达：10°C~55°C，精度±3°C；盐溶液浓度5%之盐水喷雾试验机，室温为25°C±5°C，湿度65±5% RH，测试时间按照作业规范进行测试

The temperature control range of the test should be as follows: 10 RH ~55, precision = 3; salt solution concentration 5 % salt spray test machine, room temperature is 25 + 5, humidity 65 + 5%, test time according to the operation specification test

3.外观检查 (Check the appearance of the product)

Visual no rust and other defects, electrical performance in line with product specifications.

目视无生锈等不良，电气性能符合产品规格要求。

测试结果 (Test Results)

:

- | | | | | |
|--|---|------|--------------------------|------|
| 1.外观检查 (Check the appearance of the product) | ■ | PASS | <input type="checkbox"/> | FAIL |
| 2.盐雾测试 (Salt fog Test) | ■ | PASS | <input type="checkbox"/> | FAIL |
| 3.外观检查 (Check the appearance of the product) | ■ | PASS | <input type="checkbox"/> | FAIL |

RF-QA-0026-A1

第1页 / 共3页

Laboratory Test Report

测试项目 (Test Description) :

1.产品外观检查(Check the appearance of the product)
Standard : See Test Method

数量 (Quantity) : 4 PCS

Test Result

| | | | | | |
|--------|----------|----------|----------|----------|----------|
| NO. | sample-1 | sample-2 | sample-3 | sample-4 | sample-5 |
| Result | PASS | PASS | PASS | PASS | |

Conclusion : ■ PASS □ FAIL

2.盐雾测试 (Salt Spray Test Report)

Standard : See Test Method

数量 (Quantity) : 4 PCS

Test Result

| | | | | | |
|--------|----------|----------|----------|----------|----------|
| NO. | sample-1 | sample-2 | sample-3 | sample-4 | sample-5 |
| Result | PASS | PASS | PASS | PASS | |

Conclusion : ■ PASS □ FAIL

3.检验产品外观 (Check the appearance of the product)

Standard : See Test Method

数量 (Quantity) : 4 PCS

| | | | | | |
|--------|----------|----------|----------|----------|----------|
| NO. | sample-1 | sample-2 | sample-3 | sample-4 | sample-5 |
| Result | PASS | PASS | PASS | PASS | |

Conclusion : ■ PASS □ FAIL

RF-QA-0026-A1

第2页 / 共3页

测试照片 (Test Photos)



Step 2.检查产品外观 (Check the appearance of the product) .



Step 3.盐雾测试 (Salt Spray Test Report)



Step 4.检查产品外观 (Check the appearance of the product)

备注：产品测试后无生锈等不良，判合格

~ ~ The End Of Test Report ~ ~

Approved : 龙爱云

Checked : 杨文华

Tester 肖芳芳

RF-QA-0026-A1
第3页 / 共3页

Laboratory Test Report

旋转测试报告 (Rotation test report)

厂商/客户 (Manufacturer / customer) : 启基 **生产日期 (Date of manufacture) :** 2020/7/2
设备编号 (NO.): RF-S010-01 **测试日期 (Test date):** 2020/7/2/60次/分钟, 旋转
品名 (Part Name) : 外置天线 **规格 (Specifications) :** 角度 : 360度300秒
料号 (Part No.) : RF21S00940A **旋转时间 (Rotation times) :**
测试期间 (Testing Period) : 2020-6-22/8:40~9:05 **材质 (Texture of material) :** /
测试项目 (Test Description) :

- 1.外观检查(Check the appearance of the product)
- 2.旋转测试 (Rotation test)
- 3.外观检查(Check the appearance of the product)
- 4.扭力测试 (The torsion test)

1.外观检查(Check the appearance of the product)
No obvious breakage or crack
不得有明显破损或裂纹等不良

2.旋转测试 (Rotation Test)

3.外观检查(Check the appearance of the product)
No obvious breakage or crack
不得有明显破损或裂纹等不良

4.扭力测试 (The torsion test)
扭力大于0.25kg且小于0.6kg
Torque is greater than 0.25kg and less than 0.6kg

测试结果 (Test Results) :

| | | | | |
|--|-------------------------------------|------|-------------------------------------|------|
| 1.外观检查 (Check the appearance of the product) | <input checked="" type="checkbox"/> | PASS | <input type="checkbox"/> | FAIL |
| 2.旋转测试 (Rotation Test) | <input checked="" type="checkbox"/> | PASS | <input type="checkbox"/> | FAIL |
| 3.外观检查Check the appearance of the product | <input checked="" type="checkbox"/> | PASS | <input type="checkbox"/> | FAIL |
| 4.扭力测试 (The torsion test) | <input type="checkbox"/> | PASS | <input checked="" type="checkbox"/> | FAIL |

测试项目 (Test Description) :

1.检验产品外观 (Check the appearance of the product) **数量 (Quantity) :** 4 **PCS**
 Standard : Appearance No damage

Test Result

| NO. | sample-1 | sample-2 | sample-3 | sample-4 | sample-5 |
|--------|----------|----------|----------|----------|----------|
| Result | PASS | PASS | PASS | PASS | PASS |

Conclusion : PASS FAIL

2.旋转测试 (Bending Test) **数量 (Quantity) :** 4 **PCS**

Standard : See Test Method

Test Result

| NO. | sample-1 | sample-2 | sample-3 | sample-4 | sample-5 |
|--------|----------|----------|----------|----------|----------|
| Result | PASS | PASS | PASS | PASS | PASS |

Conclusion : PASS FAIL

3.检验产品外观 (Check the appearance of the product) **数量 (Quantity) :** 4 **PCS**

Standard : Appearance No damage

Test Result

| NO. | sample-1 | sample-2 | sample-3 | sample-4 | sample-5 |
|--------|----------|----------|----------|----------|----------|
| Result | PASS | PASS | PASS | PASS | PASS |

Conclusion : PASS FAIL

4.扭力测试 (The torsion test) **数量 (Quantity) :** 4 **PCS**

| NO. | sample-1 | sample-2 | sample-3 | sample-4 | sample-5 |
|--------|----------|----------|----------|----------|----------|
| Result | 0.6kgf | 0.6kgf | 0.5kgf | 0.6kgf | 0.6kgf |

PASS FAIL

RF-QA-0026-A1

测试照片 (Test Photos) :

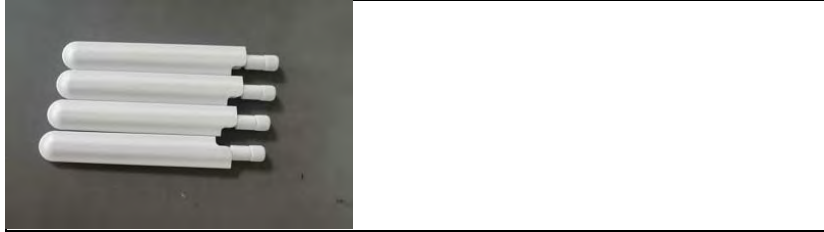

Step 2. 产品外观检查 (Product appearance inspection)



Step 3. 旋转测试图片 (Rotation Test) .



Step4. 产品外观检查 (Product appearance inspection)

备注：测试后无明显破损或裂纹等不良，符合产品规格要求，扭力测试符合标准值，判OK

~ ~ The End Of Test Report ~ ~

Approved : 龙菱云

Checked : 杨文华

Tester 肖芳芳

Laboratory Test Report

弯折测试报告 (Bending Test Report)

厂商/客户 (Manufacturer / customer) : 启基 **生产日期 (Date of manufacture) :** 2020/7/2
设备编号 (NO.): RF-S010-01 **测试日期 (Test date):** 2020/7/2/40次/分钟, 弯折
品名 (Part Name) : 外置天线 **规格 (Specifications) :** 角度 : 90度500次
料号 (Part No.) : RF21S00940A **折弯次数 (Bending times) :**
测试期间 (Testing Period) : 2020-6-21/14:40~14:55 **材质 (Texture of material) :** /
测试项目 (Test Description) :

- 1.外观检查(Check the appearance of the product)
 - 2.弯折测试 (Bending Test)
 - 3.外观检查(Check the appearance of the product)
- 1.外观检查(Check the appearance of the product)
No obvious breakage or crack
不得有明显破损或裂纹等不良
- 2.弯折测试 (Bending Test)
Bending frequency: 40 beats per minute, bending angle: 90 degrees
Swing number: ABS material and PC/ABS material on the solid and ABS material and PC/ABS material or solid rod sleeve when bending 100 times, 200 times for the bending fold of other materials
弯折频率 : 40次/分钟, 弯折角度 : 90度
摇摆次数 : A B S 料及 P C / A B S 料上固与 A B S 料及 P C / A B S 料下固或杆套时弯折100次, 其它材质为弯折200次
- 3.外观检查(Check the appearance of the product)
No obvious breakage or crack
不得有明显破损或裂纹等不良

测试结果 (Test Results) :

| | | | | |
|--|---|------|--------------------------|------|
| 1.外观检查 (Check the appearance of the product) | ■ | PASS | <input type="checkbox"/> | FAIL |
| 2.弯折测试 (Bending Test) | ■ | PASS | <input type="checkbox"/> | FAIL |
| 3.外观检查Check the appearance of the product | ■ | PASS | <input type="checkbox"/> | FAIL |

测试项目 (Test Description) :

1.检验产品外观 (Check the appearance of the product) **数量 (Quantity) :** 4 **PCS**
 Standard : Appearance No damage

Test Result

| NO. | sample-1 | sample-2 | sample-3 | sample-4 | sample-5 |
|--------|----------|----------|----------|----------|----------|
| Result | PASS | PASS | PASS | PASS | |

Conclusion : ■ PASS FAIL

2.弯折测试 (Bending Test) **数量 (Quantity) :** 4 **PCS**
 Standard : See Test Method

Test Result

| NO. | sample-1 | sample-2 | sample-3 | sample-4 | sample-5 |
|--------|----------|----------|----------|----------|----------|
| Result | PASS | PASS | PASS | PASS | |

Conclusion : ■ PASS FAIL

3.检验产品外观 (Check the appearance of the product) **数量 (Quantity) :** 4 **PCS**
 Standard : Appearance No damage

Test Result

| NO. | sample-1 | sample-2 | sample-3 | sample-4 | sample-5 |
|--------|----------|----------|----------|----------|----------|
| Result | PASS | PASS | PASS | PASS | |

Conclusion : ■ PASS FAIL

测试照片 (Test Photos) :

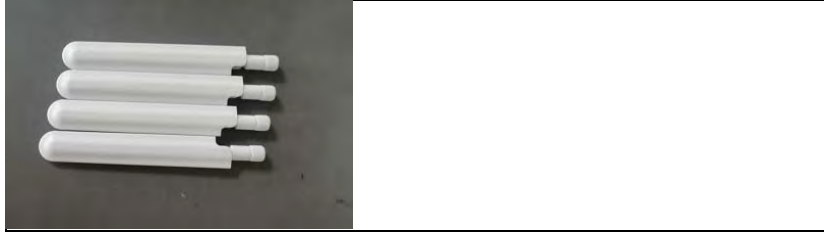

Step 2. 产品外观检查 (Product appearance inspection)



Step 3. 弯折测试图片 (Bend test pictures) .

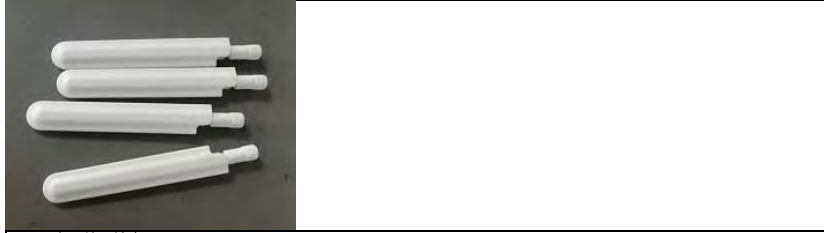

Step4. 产品外观检查 (Product appearance inspection)

备注：测试后无明显破损或裂纹等不良，符合产品规格要求，判合格

~~ The End Of Test Report ~~

Approved : 龙菱云

Checked : 杨文华

Tester 肖芳芳

测试照片 (Test Photos) :



Step 1.产品外观检查图片 (Product appearance inspection picture).



Step2.测试图片 (Test picture)

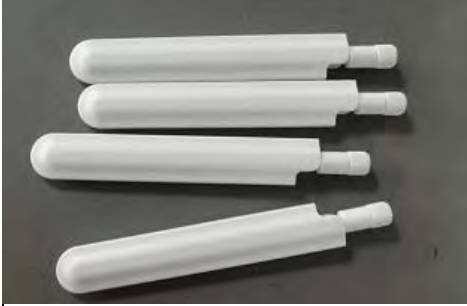

Step 3.产品外观检查图片 (Product appearance inspection picture).

备注：经冷热冲击测试后，外观无明显不良，判合格

~ ~ The End Of Test Report ~ ~

Approved : 龙爱云

Checked : 杨文华

Tester 肖芳芳

Laboratory Test Report

跌落测试报告 (Drop Test Report)

厂商/客户 (Manufacturer / customer) : 启基

生产日期 (Date of manufacture) : 2020/7/2

设备编号 (NO.): RF-S027-01

测试日期 (Test date): 2020/7/2

品名 (Part Name) : 外置天线

规格 (Specifications) :

品名 (Part Name) : 外置天线

规格 (Specifications) : 六面跌落(1次)

料号 (Part No.) : RF21S00940A

跌落高度 (Drop height): 100CM

测试期间 (Testing Period) : 2020-7-2/11 : 25-12 : 00

测试项目 (Test Description)

- : 1.外观检查 (Check the appearance of the product)
- 2.跌落测试 (Drop Test)
- 3.外观检查 (Check the appearance of the product)
- 4.电性测试 (The electrical test)

测试方法 (Test Method)

- : 1.产品外观检查(Check the appearance of the product)
No visual damage and other bad
目视无明显破损等不良
- 2.跌落测试 (Drop test)
The packing box / single product which needs to be tested is fixed on the product bracket to fix the clamping test sample, the clamping force shall be appropriate. the falling height of 100 cm shall be adjusted, and the drop box / sample shall be subjected to a drop test of three edges.
先将需要测试的包装箱/单个产品固定在产品支架上固定装夹试验样品,夹紧力应适当.调节跌落高度 100 CM , 跌落包装箱/样品进行一角三棱六面跌落测试.
- 3.外观检查(Check the appearance of the product)
No obvious breakage or crack , Electrical properties meet product specifications
不得有明显破损或裂纹等不良, 电气性能符合产品规格要求.
- 4.电性测试 (The electrical test)
符合电性要求
(Meet electrical requirements)

测试结果 (Test Results)

- : 1.外观检查 (Check the appearance of the product) ■ **FAIL**
- 2.跌落测试 (Drop Test) ■ **PASS** **FAIL**
- 3.外观检查 (Check the appearance of the product) ■ **PASS** **FAIL**
- 4.电性测试 (The electrical test) ■ **PASS** **FAIL**

| | | | | | |
|--------|----------|----------|----------|----------|----------|
| NO. | sample-1 | sample-2 | sample-3 | sample-4 | sample-5 |
| Result | PASS | PASS | PASS | PASS | |

Conclusion : ■ **PASS** □ **FAIL**

2.冷热冲击测试 (Hot and cold shock test) 数量 (Quantity) : 4 PCS

Standard : See Test Method

Test Result

| | | | | | |
|--------|----------|----------|----------|----------|----------|
| NO. | sample-1 | sample-2 | sample-3 | sample-4 | sample-5 |
| Result | PASS | PASS | PASS | PASS | |

Conclusion : ■ **PASS** □ **FAIL**

3.检验产品外观 (Check the appearance of the product) 数量 (Quantity) : 4 PCS

Standard : See Test Method

Test Result

| | | | | | |
|--------|----------|----------|----------|----------|----------|
| NO. | sample-1 | sample-2 | sample-3 | sample-4 | sample-5 |
| Result | PASS | PASS | PASS | PASS | |

Conclusion : ■ **PASS** □ **FAIL**



Step 2. Check the appearance of the product. (检查产品外观)



Step 3. Product drop test -A surface
(产品跌落测试-A面)



Step 4. Product drop test -B surface
(产品跌落测试-B面)



Step 5. Product drop test -C surface
(产品跌落测试-C面)



Step 6. Product drop test -D surface
(产品跌落测试-D面)

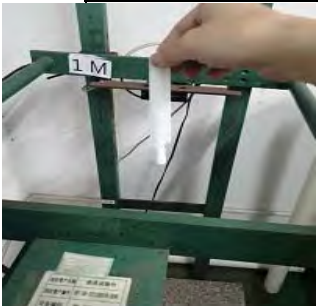

Step 7. Product drop test -E surface
(产品跌落测试-E面)



Step 8. Product drop test -F surface
(产品跌落测试-F面)



Step 9. Check the appearance of the product. (检查产品外观)

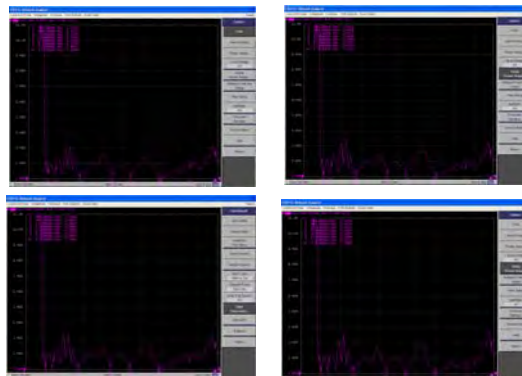

Step 10. 电性测试 (The electrical test)

备注：测试后无明显破损或裂纹等不良，电性符合要求，判合格。

~ ~ The End Of Test Report ~ ~

Laboratory Test Report

推力测试报告 (Thrust test report)

| | | |
|--|------------------------------|-------------|
| 厂商/客户 (Manufacturer / customer) 启基 | 生产日期 (Date of manufacture) | 2020/7/2 |
| 设备编号 (NO.): RF-LG-089 | 测试日期 (Test date): | 2020/7/2 |
| 品名 (Part Name) : 外置天线 | 规格 (Specifications) : | 1.5kgf |
| 料号 (Part No.) : RF21S00940A | 推力标准 (Tension standard) | |
| 测试期间 (Testing Period) : 2020-7-2/16:00~16:20 | 测试位置 (Test location) | 活动铆接处往上50MM |

测试项目 (Test Description) :

- 1.外观检查 (Check the appearance of the product)
- 2.推力测试 (Thrust test)
- 3.外观检查 (Check the appearance of the product)

测试方法 (Test Method) :

- 1.外观检查 (Check the appearance of the product)
Visual no off, deformation.Loose and other defects
目视无脱落，变形，松动等不良。
- 2.推力测试 (Thrust test)
The test sample is fixed in the test fixture,
and the test product is tested by the thrust meter,
and then the value on the thrust meter is read and recorded
将测试样品固定在测试治具内，使用推力计对测试产品进行推力测试，
然后读取推力计上的数值进行记录
- 3.外观检查 (Check the appearance of the product)
Visual no off, deformation.Loose and other defects
目视无脱落，变形，松动等不良。

测试结果 (Test Results) :

| | | | | |
|--|---|------|---|------|
| 1.外观检查 (Check the appearance of the product) | ■ | PASS | □ | FAIL |
| 2.推力测试 (Thrust test) | ■ | PASS | □ | FAIL |
| 3.外观检查 (Check the appearance of the product) | ■ | PASS | □ | FAIL |

测试项目 (Test Description) :

1..产品外观检查(Check the appearance of the product) 数量 (Quantity) : 4 PCS
Standard : See Test Method

| NO. | sample-1 | sample-2 | sample-3 | sample-4 | sample-5 |
|-------------------|----------|----------|----------|----------|----------|
| Result | PASS | PASS | PASS | PASS | |
| Conclusion | : ■ PASS | | | | □ FAIL |

2.推力测试 (Thrust test) 数量 (Quantity) : 4 PCS
Standard : See Test Method

| NO. | sample-1 | sample-2 | sample-3 | sample-4 | sample-5 |
|-------------------|----------|----------|----------|----------|----------|
| Result | 1.53kgf | 1.63kgf | 1.56kgf | 1.67kgf | |
| Conclusion | : ■ PASS | | | | □ FAIL |

3.检验产品外观 (Check the appearance of the product) 数量 (Quantity) : 4 PCS
Standard : See Test Method

| NO. | sample-1 | sample-2 | sample-3 | sample-4 | sample-5 |
|-------------------|----------|----------|----------|----------|----------|
| Result | PASS | PASS | PASS | PASS | |
| Conclusion | : ■ PASS | | | | □ FAIL |

测试照片 (Test Photos) :



Step 1. 产品外观检查 (Product appearance inspection)

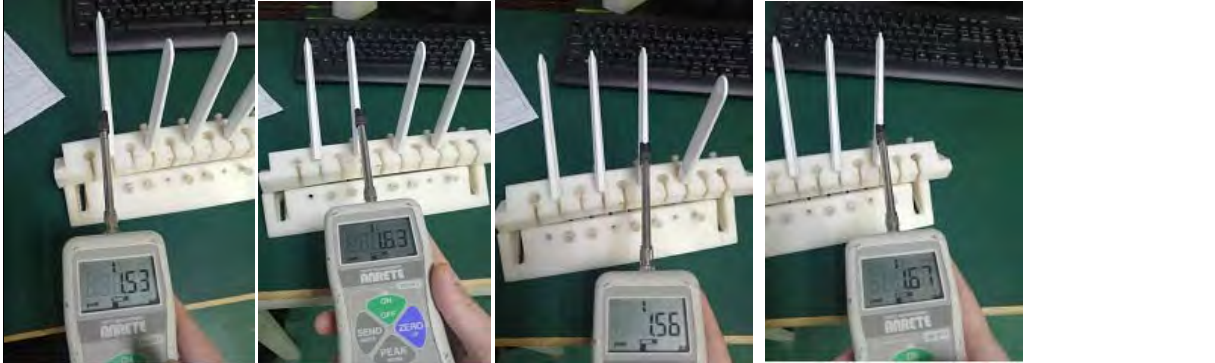

Step 2. 测试图片 (Test picture)



Step 3. 产品外观检查 (Product appearance inspection)

备注：测试推力大于标准值，判合格

~~ The End Of Test Report ~~

Approved : 龙爱云

Checked : 杨文华

Tester 肖芳芳

电磁振动测试 (Electromagnetic vibration test)

| | | |
|--|---|--|
| 厂商/客户 (Manufacturer / customer) : 启基 | 生产日期 (Date of manufacture) : 2020/7/15 | |
| 设备编号 (NO.): RF-YQ-219 | 测试日期 (Test date): 2020/7/15 | |
| 品名 (Part Name) : 外置天线 | 测试期间 (Testing Period) : 2020-7-15/18:10~20:30 | |
| 料号 (Part No.) : RF21S00940A | 规格 (Specifications) : 3个轴方向, 1个循环, 每个循环30分钟 | |

振动频率 (vibrational frequency) : 5~10Hz 50~100Hz

测试项目 (Test Description) :

- 1.网络分析仪测试 (Vector Network Analyzer Test)
- 2.产品外观检查 (Check the appearance of the product)
- 3.电磁振动测试 (Electromagnetic vibration test)
- 4.外观检查 (Check the appearance of the product)
- 5.网络分析仪测试 (Vector Network Analyzer Test)

测试方法 (Test Method) :

- 1.网络分析仪测试 (Vector Network Analyzer Test)
E5071C
Frequency Range :
Rreturn loss :
V.S.W.R :
Gain :
- 2.产品外观检查 (Check the appearance of the product)
The firmware is not loose, the parts are not broken or fatigue;
No original parts fall off, etc
固件无松散、部件无破裂或疲劳；无原件脱落等
- 3.电磁振动测试 (Electromagnetic vibration test)
Frequency: 30~60Hz; Amplitude: 0.38 mm
Duration: X,Y&Z 30 minutes in each direction
Cycle: 1 min
频率：10~30Hz 30~-50Hz；振幅：0.35mm 0.75mm
持续时间：X,Y&Z每个方向30分钟
周期：1min
- 4.产品外观检查 (Check the appearance of the product)
The firmware is not loose, the parts are not broken or fatigue;
No original parts falling off, no broken solder spots;
Electrical performance indicators meet the technical specifications
固件无松散、部件无破裂或疲劳；无原件脱落、无焊锡点断裂；电性能指标满足技术规格要
- 5.网络分析仪测试 (Vector Network Analyzer Test)
E5071C
Frequency Range :
Rreturn loss :
V.S.W.R :
Gain :

测试结果 (Test Results) :

- | | | | | |
|--|-------------------------------------|------|--------------------------|------|
| 1.网络分析仪测试 (Vector Network Analyzer Test) | <input type="checkbox"/> | PASS | <input type="checkbox"/> | FAIL |
| 2.外观检查 (Check the appearance of the product) | <input checked="" type="checkbox"/> | PASS | <input type="checkbox"/> | FAIL |
| 3.电磁振动测试 (Electromagnetic vibration test) | <input checked="" type="checkbox"/> | PASS | <input type="checkbox"/> | FAIL |
| 4.外观检查 (Check the appearance of the product) | <input checked="" type="checkbox"/> | PASS | <input type="checkbox"/> | FAIL |
| 5.网络分析仪测试 (Vector Network Analyzer Test) | <input type="checkbox"/> | PASS | <input type="checkbox"/> | FAIL |

测试项目 (Test Description) :

1.网络分析仪测试 (Vector Network Analyzer Test) 数量 (Quantity) : PCS

Standard : See Test Method

Test Result

| NO. | sample-1 | sample-2 | sample-3 | sample-4 | sample-5 |
|--------|----------|----------|----------|----------|----------|
| Result | | | | | |

Conclusion : PASS FAIL

2.检验产品外观 (Check the appearance of the product) 数量 (Quantity) : 3 PCS

Standard : See Test Method

Test Result

| NO. | sample-1 | sample-2 | sample-3 | sample-4 | sample-5 |
|--------|----------|----------|----------|----------|----------|
| Result | PASS | PASS | PASS | | |

Conclusion : PASS FAIL

3.电磁振动测试 (Electromagnetic vibration test) 数量 (Quantity) : 3 PCS

Standard : See Test Method

Test Result

| NO. | sample-1 | sample-2 | sample-3 | sample-4 | sample-5 |
|--------|----------|----------|----------|----------|----------|
| Result | PASS | PASS | PASS | | |

Conclusion : PASS FAIL

4.检验产品外观 (Check the appearance of the product) 数量 (Quantity) : 3 PCS

Standard : See Test Method

Test Result

| NO. | sample-1 | sample-2 | sample-3 | sample-4 | sample-5 |
|--------|----------|----------|----------|----------|----------|
| Result | PASS | PASS | PASS | | |

Conclusion : PASS FAIL

5.网络分析仪测试 (Vector Network Analyzer Test) 数量 (Quantity) : PCS

Standard : Appearance No damage

Test Result

| NO. | sample-1 | sample-2 | sample-3 | sample-4 | sample-5 |
|--------|----------|----------|----------|----------|----------|
| Result | | | | | |

Conclusion : PASS FAIL

测试照片 (Test Photos) :

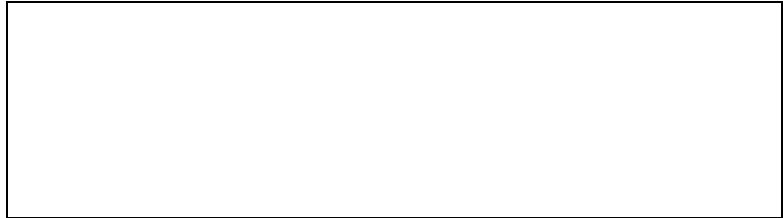

Step 1. 网络分析仪测试 (Vector Network Analyzer Test)



Step 2. 检验产品外观 (Check the appearance of the product)



Step 3. 电磁振动测试 (Electromagnetic vibration test)



Step 4. 检验产品外观 (Check the appearance of the product)



Step 5. 网络分析仪测试 (Vector Network Analyzer Test)

备注：测试后无松散、部件无破裂或疲劳；无原件脱落、无焊锡点断裂；电性能指标满足技术规格要求，判合格。

~~ The End Of Test Report ~~

Approved : 龙爱云

Checked 杨冬芳

Tester : 肖芳芳

Laboratory Test Report

整箱跌落测试报告 (Drop Test Report)

| | | |
|----------------------------------|------------------------------|-----------|
| 厂商/客户 (Manufacturer / custom 启基) | 生产日期 (Date of manufacture) : | 2020-7-15 |
| 设备编号 (NO.): RF-S027-01 | 测试日期 (Test date): | 2020-7-15 |
| 品名 (Part Nam) : 外置天线 | 规格 (Specifications) : | 六面跌落(10次) |
| 料号 (Part No.) : RF21S00940A | 跌落高度 (Drop height): | 81CM |

测试期间 (Testing Period) 2020-7-15/14:20~14:30

测试项目 (Test Description) :

- 1.外观检查 (Check the appearance of the product)
- 2.跌落测试 (Drop Test)
- 3.外观检查 (Check the appearance of the product)

1.产品外观检查(Check the appearance of the product)

No visual damage and other bad
目视无明显破损等不良

2.跌落测试 (Drop test)

The packing box / single product which needs to be tested is fixed on the product bracket to fix the clamping test sample, the clamping force shall be appropriate. the falling height of 100 cm shall be adjusted, and the drop box / sample shall be subjected to a drop test of three edges.

先将需要测试的包装箱/单个产品固定在产品支架上固定装夹试验样品,夹紧力应适当.调节跌落高度 100 CM, 跌落包装箱/样品进行一角三棱六面跌落测试。

3.外观检查(Check the appearance of the product)

No obvious breakage or crack , Electrical properties meet product specifications
不得有明显破损或裂纹等不良 , 电气性能符合产品规格要求。

测试结果 (Test Results) :

| | | | | |
|--|---|------|--------------------------|------|
| 1.外观检查 (Check the appearance of the product) | ■ | PASS | <input type="checkbox"/> | FAIL |
| 2.跌落测试 (Drop Test) | ■ | PASS | <input type="checkbox"/> | FAIL |
| 3.外观检查 (Check the appearance of the product) | ■ | PASS | <input type="checkbox"/> | FAIL |

Laboratory Test Report

测试项目 (Test Description) :

1. 检验产品外观 (Check the appearance of the product)

数量 (Quantity) : 1箱 PCS

Standard : See Test Method

Test Result

| | | | | |
|--------|----------|----------|----------|----------|
| NO. | sample-1 | sample-2 | sample-3 | sample-4 |
| Result | PASS | | | |

Conclusion : PASS FAIL

2. 跌落测试 (Drop Test)

数量 (Quantity) : 1箱 PCS

Standard : See Test Method

Test Result

| | | | | |
|--------|----------|----------|----------|----------|
| NO. | sample-1 | sample-2 | sample-3 | sample-4 |
| Result | PASS | | | |

Conclusion : PASS FAIL

3. 检验产品外观 (Check the appearance of the product)

数量 (Quantity) : 1箱 PCS

Standard : See Test Method

Test Result

| | | | | |
|--------|----------|----------|----------|----------|
| NO. | sample-1 | sample-2 | sample-3 | sample-4 |
| Result | PASS | | | |

Conclusion : PASS FAIL

Laboratory Test Report

测试照片 (Test Photos) :



Step 2. Check the appearance of the product.
(检查产品外观)



Step 3. Product drop test -A surface
(产品跌落测试-A面)



Step 4. Product drop test -B surface
(产品跌落测试-B面)

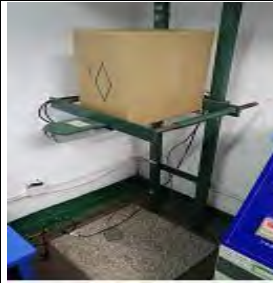

Step 5. Product drop test -C surface
(产品跌落测试-C面)



Step 6. Product drop test -D surface
(产品跌落测试-D面)



Step 7. Product drop test -E surface
(产品跌落测试-E面)



Step 8. Product drop test -F surface
(产品跌落测试-F面)



Step 9. Check the appearance of the product.
(检查产品外观)



备注：测试后无明显破损或裂纹等不良,判合格。

~ ~ The End Of Test Report ~ ~

锁附力报告 (Force test of male nut lock)

厂商/客户 (Manufacturer / customer) : 启基 **生产日期 (Date of manufacture) :** 2020-7-24
设备编号 (NO.): RF-YQ-86 **测试日期 (Test date):** 2020-7-24
品名 (Part Name) : 外置天线 **规格 (Specifications) :** /
料号 (Part No.) : RF21S00940A **锁附力标准 (Lock attached to the force)**1.0kgf~2.5kgf

测试期间 (Testing Period) : 2020-7-24/8:30~8:50

测试项目 (Test Description) :

- 1.外观检查 (Check the appearance of the product)
- 2.扭力测试 (The torsion test)
- 3.外观检查 (Check the appearance of the product)

测试方法 (Test Method) :

- 1.外观检查 (Check the appearance of the product)
No deformation, oxidation, looseness, etc
目视无变形, 氧化, 松动等不良
- 2.扭力测试 (The torsion test)
Adjust the torsion meter to make it return to the zero state and load and clip the test sample;Conduct torque test of products;At the end of the test, record the test results.
调整扭力计, 使扭力计归零状态, 装夹好测试样品; 进行产品的扭力试验; 测试结束时, 记录测试结果。
- 3.外观检查 (Check the appearance of the product)
No deformation, oxidation, looseness, etc
目视无变形, 氧化, 松动等不良

测试结果 (Test Results) :

| | | | | |
|--|---|------|--------------------------|------|
| 1.外观检查 (Check the appearance of the product) | ■ | PASS | <input type="checkbox"/> | FAIL |
| 2.扭力测试 (The torsion test) | ■ | PASS | <input type="checkbox"/> | FAIL |
| 3.外观检查 (Check the appearance of the product) | ■ | PASS | <input type="checkbox"/> | FAIL |

测试项目 (Test Description) :

1..产品外观检查(Check the appearance of the product) **数量 (Quantity) :** 3 PCS
 Standard : See Test Method

| Test Result | | | | | |
|-------------------|----------|----------|----------|----------|-------------------------------|
| NO. | sample-1 | sample-2 | sample-3 | sample-4 | sample-5 |
| Result | PASS | PASS | PASS | | |
| Conclusion | : | | ■ | PASS | <input type="checkbox"/> FAIL |

2.扭力测试 (The torsion test) **数量 (Quantity) :** 3 PCS
 Standard : See Test Method

| Test Result | | | | | |
|-------------------|----------|----------|----------|----------|-------------------------------|
| NO. | sample-1 | sample-2 | sample-3 | sample-4 | sample-5 |
| Result | 1.5kgf | 1.1kgf | 1.8kgf | | |
| Conclusion | : | | ■ | PASS | <input type="checkbox"/> FAIL |

3.检验产品外观 (Check the appearance of the product) **数量 (Quantity) :** 3 PCS
 Standard : See Test Method

| Test Result | | | | | |
|-------------------|----------|----------|----------|----------|-------------------------------|
| NO. | sample-1 | sample-2 | sample-3 | sample-4 | sample-5 |
| Result | PASS | PASS | PASS | | |
| Conclusion | : | | ■ | PASS | <input type="checkbox"/> FAIL |

测试照片 (Test Photos) :



Step 1. 产品外观检查 (Product appearance inspection)



Step 2. 测试图片 (Test picture)



Step 3. 产品外观检查 (Product appearance inspection)

备注：测试后SMA附力大于1.0kgf且未达到2.5kgf，无变形，松动，判合格。

~ ~ The End Of Test Report ~ ~

Approved : 龙爱云

Checked 韦云忠

Tester : 肖芳芳

测试照片 (Test Photos) :



Step 1. 产品外观检查 (Product appearance inspection)

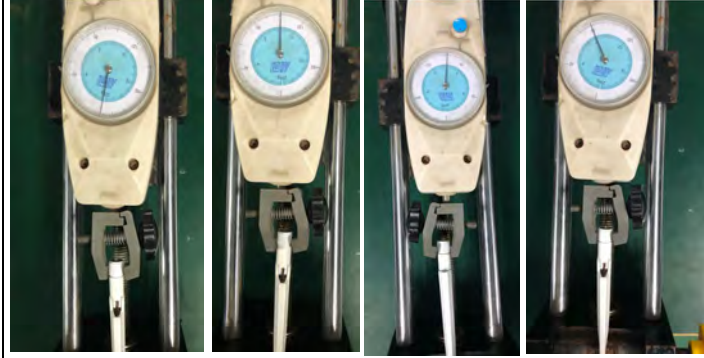

Step 2. 测试图片 (Test picture)



Step 3. 产品外观检查 (Product appearance inspection)

备注：测试后拉力 \geq 8kgf，判合格。

~~ The End Of Test Report ~~

Approved : 龙爱云

Checked 韦云忠

Tester : 肖芳芳

Laboratory Test Report

电镀测试报告 (Thrust test report)

厂商/客户 (Manufacturer / customer) 启基 生产日期 (Date of manufacture) 2020/07/21

设备编号 (NO.): 测试日期 (Test date): 2020/07/21

品名 (Part Name) : SMA 电镀说明 (Plating specification)

料号 (Part No.) : 200C00210A MSA为镀镍 : 镀镍80μ

测试期间 (Testing Period) : 2020-07-21/11:45 镀镍≥80μ为合格

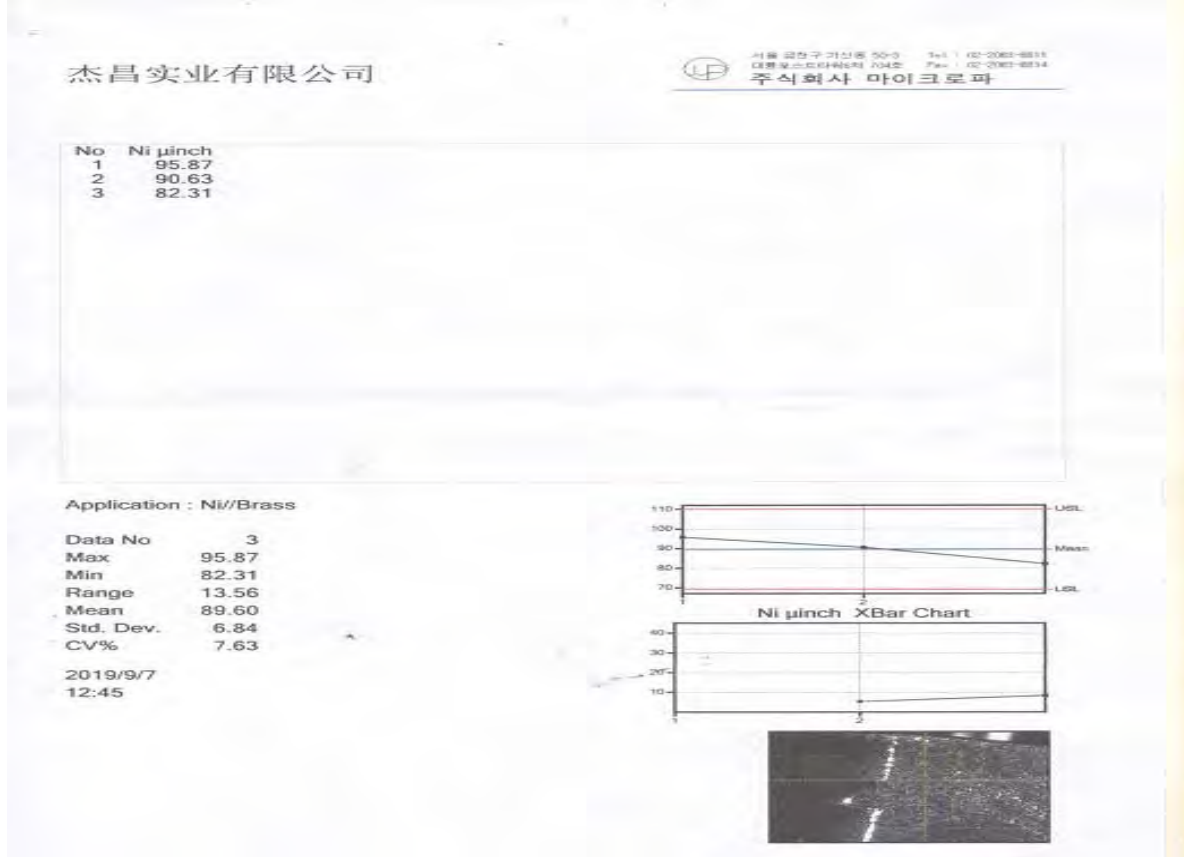

| | | | | | |
|-------|--|-------|--|-------|--|
| 1 | | 2 | | 3 | |
| 95.87 | | 90.63 | | 82.31 | |

■ PASS PCS ■ PASS ■ PASS

Laboratory Test Report

电镀测试报告 (Thrust test report)

厂商/客户 (Manufacturer / customer) 启基 生产日期 (Date of manufacture) 2020/07/21

设备编号 (NO.): 测试日期 (Test date): 2020/07/21

品名 (Part Name) : PIN针 电镀说明 (Plating specification)

料号 (Part No.) : 200C00210A PIN为镀镍后再镀金 : 镀镍80u : 镀金1u
 镀镍≥80μ为合格 镀金≥1μ为合格

测试期间 (Testing Period) : 2020-07-21/11:45

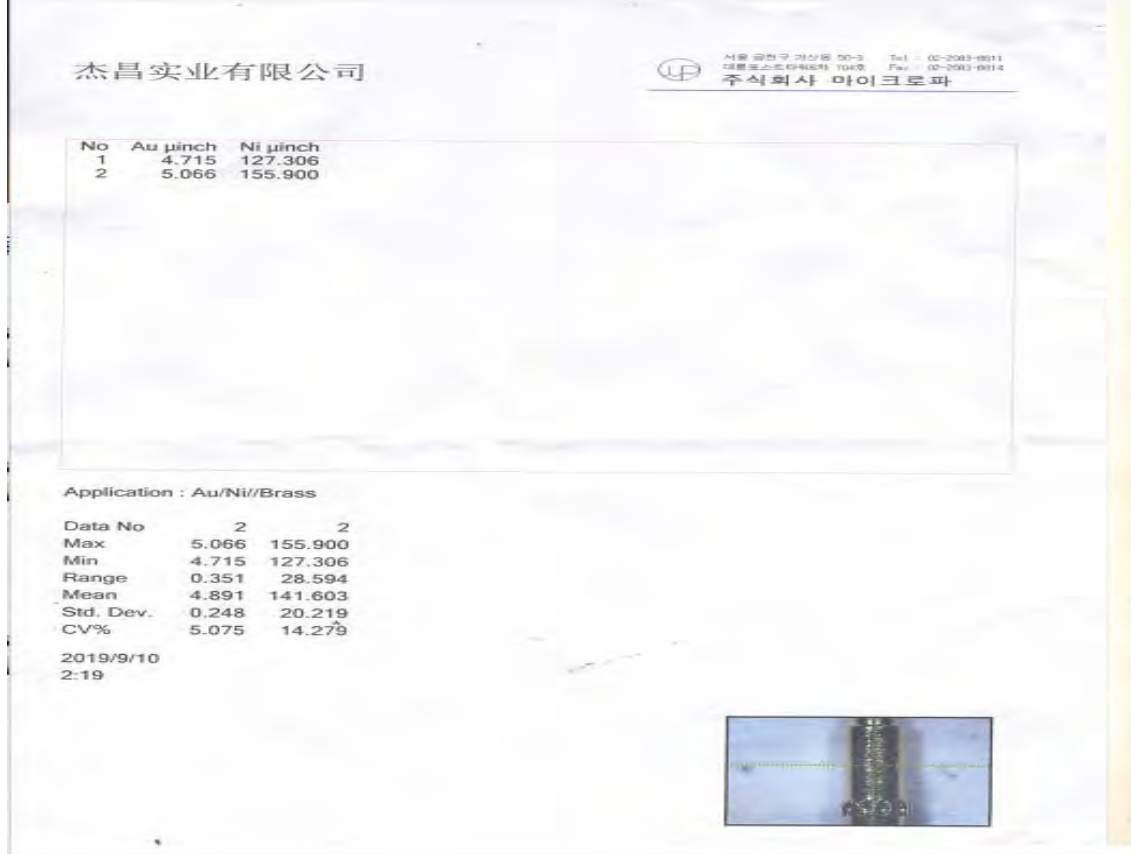

| | | | | | |
|-------|--|-------|--|--|--|
| 1 | | 2 | | | |
| 4.715 | | 5.066 | | | |

■ PASS PCS ■ PASS ■ PASS

数量 (Quantity) :