

SWA20, 2.4GHz User Manual

High Resolution Wireless I2S Audio, based on the Skyworks SKY76305

General Description

The SWA20 module is a member of the UL2X family of wireless module products. The UL2X module product concept offers customers fast time to market for point-to-multipoint mono, stereo, or multichannel wireless audio connection. It incorporates Skyworks newest wireless audio chip, Sky76305.

The UL2X family of devices are the 5th generation of Skyworks cognitive transceivers. They operate in the 2.4 GHz ISM Band. The audio system protocol that they utilize is known as UL2X. The SKY76305 devices enable wireless audio modules supporting Soundbar, TV speaker accessories as well as general Wireless USB-connected audio applications.

Like its predecessors, uncompressed, very low fixed and synchronized-latency audio is the key differentiator of the new UL2X radio protocol. The SWA20 further builds upon the Skyworks legacy by adding higher channel count, greatly lowered power consumption, more application memory and a modern embedded microcontroller for support of more sophisticated and capable end-products. The SKY76305 is supported by a range of modules intended for various wireless consumer-audio, pro-audio and home-theater applications.

The SWA20 module hardware integrates all components necessary to complete a 2.4 GHz wireless multi-client, multichannel link, including SKY76305 Wireless Audio Chip, printed diversity antennas, shield can, flash memory, interface connector and all passive components. Just provide power and an I2S interface and you are ready to create a wireless audio link.

The module measures 26 x 60 x 3.3 mm and is provided with a 24 pin FPC connector.

The module is designed to pass FCC, CE, and IC along with various other regional standards.

Applications

- ✓ Hi Resolution Wireless Subwoofer, Front / Rear Speaker
- ✓ Dolby ATMOS Soundbars
- ✓ Multi-channel Soundbar

Features

- ✓ FW defined TX or RX. Same Module Hardware serves both.
- ✓ 32-bit RISC processor sub-system
- ✓ High resolution over-the-air audio and Interfaces (FW configuration dependent)
 - ✓ Up to 120 dB SNR OTA audio path
 - ✓ 3 x I2S Digital I/O up to 24 bits.
 - ✓ Stereo USB Audio I/O
- ✓ Wireless Range (Typ)
 - ✓ > 40m Indoor-Line-of-Sight range
 - ✓ > 75m Outdoor-Line-of-Sight range
- ✓ Auto-search/synch, WIFI avoidance and dynamic channel selection
- ✓ Sample rate converter: Support for 32 - 96kHz input sample rates
- ✓ General purpose over-the-air (OTA) serial interface / data channel:
 - ✓ >120 kb/s wireless data capability
 - ✓ Support for amplifier control data, meta-data, and remote-control commands
- ✓ Low, fixed latency OTA audio (<16 ms typ, I2S-to-I2S)
- ✓ Full-speed USB interface for Audio Device and Human Interface Device
- ✓ Inter-channel, Inter-client latency less than 5us (All clients at same sample rate)
- ✓ Dual printed PCB diversity antennas for multipath and fading mitigation
- ✓ 24 pin FPC connector
- ✓ RF parts can-shielded

- ✓ Module meets FCC part 15 / CE rules for emissions

Ordering Options

- ✓ SWA20-TX: Transmit module with digital audio input/ccd
- ✓ SWA20-RX: Transmit module with digital audio input/ccd



Different label color and WNC P/Ns are used to distinguish between TX and RX.

1 Table of Contents

	1
General Description	1
Applications	1
Features	1
Ordering Options	2
1 Table of Contents	3
2 Lists of Figures and Tables	4
3 Module Selector Guide	4
4 Certificate of Conformity	5
5 Revision History	5
6 Photograph	6
7.1 SWA20 Module Connections and Interfaces	7
8 SWA20 Connector Information	8
9 Electrical, Audio and Timing Specifications	10
9.1 Module ESD spec.	10
9.2 Absolute Maximum Ratings	10
9.3 Recommended Operating Range	10
9.4 Electrical Characteristics – DC Characteristics	10
9.5 Electrical Characteristics – RF PLL Characteristics	11
9.6 Electrical Characteristics – RF RX Characteristics	11
9.7 Electrical Characteristics – RF TX Characteristics	11
9.8 Electrical Characteristics – Audio C/CS	12
9.9 I ² S Communication Interface Timing	13
9.10 I2C Master/Slave Communication Interface Timing (S_SCL, S_SDA)	14
10 Ordering Information	16
11 Suggested clearance area for SWA20 printed antennas	16
12 Precaution for Use	19
13 FCC statement	20
14 IC Statement	22

2 Lists of Figures and Tables

Table 1: SWA20 Connector Information	8
Table 2: SWA20 I2S Timing	13
Table 3: Characteristics of the S_SDA and S_SCL I/Os	14
Table 4: SWA20 Module Ordering Information	16
Figure 3: SWA20 Module Simple Sub-Woofer Implementation	6
Figure 4: SWA20 Module Outline and Mechanical Dimensions	10

3 Module Selector Guide

Part No.	Model	Role
81SWA621.G01	SWA20	TX
81SWA622.G01	SWA20	RX

4 Certificate of Conformity

Countries	Certificate ID
FCC	NKR-SWA20
IC	4441A-SWA20
CE	TBD
JRF	TBD

5 Revision History

Revision	Description of Changes	Date
1.0	Initial Preliminary release	April 21 th , 2022

6 Photograph

Top Side

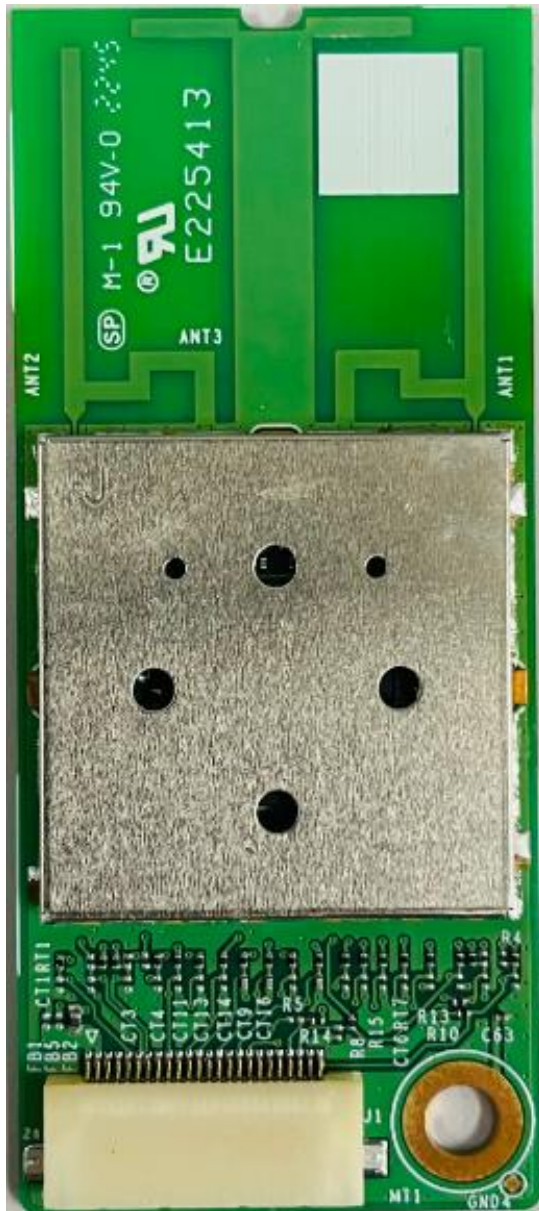

Bottom Side



7.1 SWA20 Module Connections and Interfaces

Signal Type	Description
+3.3V Supply	The SWA20 hardware is configured to accept a nominal +3.3V supply.
Reset	Active low reset input. This pin is driven from an open collector/drain device such that it can be pulled to ground for the active reset state but, when released, must go to a high impedance state. This pin should not be actively driven high, as the SKY76305 internal reset circuit will not operate correctly.
I2S In Port	The I2S input port can be configured as a master or slave. Consequently BCLK and LRCK can be either inputs or outputs. In addition, MCLK can be sourced by the module on pin 16. Since the SKY76305 IC contains a sample rate converter, MCLK is not required to be supplied to the module when it is an I2S slave. CMOS 3.3V logic levels are used for all I2S signals.
I2S Out Port	The I2S output port can be configured as a master or slave. Consequently BCLK and LRCK can be either inputs or outputs. In addition, MCLK can be sourced by the module on pin 16. Since the SKY76305 IC contains a sample rate converter, MCLK is not required to be supplied to the module when it is an I2S slave. CMOS 3.3V logic levels are used for all I2S signals.
I2C Slave Port	The I2C slave port can be used for external host communication and for module testing. It is assumed that external pull up resistors are connected at the I2C master communicating with the module.
I2C Master Port	The I2C master port is used to communicate with external audio devices such as a sub-woofer amplifier. It is assumed that external pull up resistors are included on the application board.
GPIOs	3.3V CMOS logic level GPIOs available to connect to other devices, or to use as UI supporting GPIOs for LED and button support. All supported GPIOs can be configured as outputs or inputs with configurable pull-ups/pull-downs.

8 SWA20 Connector Information

Table 1: SWA20 Connector Information

No	Pin Name	Pin Type	SKY76305 Pin	SWA20-TX Pin Description	SWA20-RX Pin Description
1	GPIO32/S_SSB/TDO	Digital I/O	B10	GPIO or SPI Slave Chip Select or JTAG Test Data Out	GPIO or SPI Slave Chip Select or JTAG Test Data Out
2	GPIO31/S_SCLK/TCK	Digital I/O	A9	GPIO or SPI Slave Serial Clock or JTAG Test Clock	GPIO or SPI Slave Serial Clock or JTAG Test Clock
3	GPIO30/S_SDA/S_MOSI/TMS	Digital I/O	B9	GPIO, I2C Slave Serial Data or SPI Slave Data or JTAG Test Mode Select	GPIO, I2C Slave Serial Data or SPI Slave Data or JTAG Test Mode Select
4	GPIO9/S_SCL/S_MISO/TDI	Digital I/O	A34	GPIO I2C Slave Serial Clock or SPI Slave Data Out or JTAG Test Data in	GPIO I2C Slave Serial Clock or SPI Slave Data Out or JTAG Test Data in
5	GPIO28/M_SDA	Digital I/O	B8	GPIO, I2C Master Serial Data	GPIO, I2C Master Serial Data
6	GPIO27/M_SCL	Digital I/O	A8	GPIO, I2C Master Serial Clock	GPIO, I2C Master Serial Clock
7	GPIO26/LINK_LED	Digital I/O	B7	GPIO, or LINK_LED Output	GPIO, or LINK_LED Output
8	GPIO25/PAIR	Digital I/O	A7	GPIO, or input from PAIR Button	GPIO, or input from PAIR Button
9	GPIO24/BCLK1	Digital I/O	B6	GPIO or I2S Port 1 Bit Clock	GPIO or I2S Port 1 Bit Clock
10	GPIO23/WCLK1	Digital I/O	A6	GPIO or I2S Port 1 Word Clock	GPIO or I2S Port 1 Word Clock
11	GPIO10/MCLK	Digital I/O	B38	GPIO or Master Clock	GPIO or Master Clock
12	GND	GND	GND Paddle	GND	GND
13	GPIO21/BCLK0	Digital I/O	A5	GPIO or I2S Port 0 Bit Clock	GPIO or I2S Port 0 Bit Clock
14	GPIO20/WCLK0	Digital I/O	B4	GPIO or I2S Port 0 Word Clock	GPIO or I2S Port 0 Word Clock
15	GPIO19/ADAT0	Digital I/O	A4	GPIO or I2S Port 0 Audio Data	GPIO or I2S Port 0 Audio Data

16	GPIO18/ADAT1	Digital I/O	B3	GPIO or I2S Port 1 Audio Data	GPIO or I2S Port 1 Audio Data
17	GPIO17/ADAT2/CEN	Digital I/O	A3	GPIO or I2S Port 2 Audio Data ⁽¹⁾ or Chip Enable ⁽⁴⁾	GPIO or I2S Port 2 Audio Data ⁽¹⁾ or Chip Enable ⁽⁴⁾
18	GPIO15/D+	Digital I/O	A44 or A2	GPIO or USB Data Plus ⁽²⁾	GPIO or USB Data Plus ⁽²⁾
19	GPIO14/D-	Digital I/O	B40 or A1	GPIO or USB Data Minus ⁽²⁾	GPIO or USB Data Minus ⁽²⁾
20	GPIO13	Digital I/O	A43	GPIO ⁽³⁾	GPIO ⁽³⁾
21	RESETN_EXT	Digital Input	B20	RESET signal active low ⁽⁵⁾	RESET signal active low ⁽⁵⁾
22	GND	GND	GND Paddle	GND	GND
23	VDD	Supply Input	A16 and A38	+3.3V input supply voltage	+3.3V input supply voltage
24	VDD	Supply Input	A16 and A38	+3.3V input supply voltage	+3.3V input supply voltage

Notes:

- (1) In 6 Channels application, ADAT2 will share I2S clocks from ADAT0 / ADAT1
- (2) Utilizing pins 18 and 19 as USB D+ and D- requires the firmware to Tri-state GPIOs 14 and 15.
- (3) Pin 20 (GPIO13) can be utilized to implement a “Data Waiting” interrupt signal for I2C and SPI Slave data communication.
- (4) Pin 17 is configured as GPIO17 by hardware in default. Utilizing this pin for CEN requires different hardware stuffing option.
- (5) Pin 21 (RESET_EXT) can be pulled to GND with a switch or an open drain/collector type device to provide a hard reset signal to the SKY76305. This pin is pulled up to VDDIO (3.3V) internally in the SKY76305 and should not be actively driven high.

9 Electrical, Audio and Timing Specifications

9.1 Module ESD spec.

CONDITION	MIN	MAX
ESD Contact HBM	4kV	----

Notes:

1) HBM = ESD Human Body Model; C = 150pF, R = 330Ω ; non-operational mode.

9.2 Absolute Maximum Ratings

PARAMETER	MIN	TYP	MAX	UNIT
Storage temperature	-40		70	°C
Storage humidity at 60°C	10		90	%RH

9.3 Recommended Operating Range

PARAMETER	MIN	TYP	MAX	UNIT
VDD, +3.3V Supply pin voltage	3.0	3.3	3.6	V
Ambient Temperature (T _A)	0		55	°C
RESET pin hold time	10			msec
Power Supply Rise Time (to 4.5V)	0		10	msec

9.4 Electrical Characteristics – DC Characteristics

Test Conditions: T_A=+25°C, VDD=+5.0V

PARAMETER	CONDITIONS	MIN	TYP	MAX	UNIT
Supply Current (IVDDA)	Standby		200		uA
	RX mode (continuous RX)		9		mA
	Link mode (for SWA20 TX)		11(tbd)		mA
	Link mode (for SWA20 RX)		11(tbd)		mA
	TX mode (continuous TX); Pout=+13dBm		15		mA
CMOS I/O Logic Levels – 1.8V I/O					
Input Voltage Logic Low, V _{IL}				0.6	V
Input Voltage Logic High, V _{IH}		VDDIO -0.6			V
Output Voltage Logic Low, V _{OL}				0.3	V

Output Voltage Logic High, VOH		VDDIO -0.3			V
--------------------------------	--	------------	--	--	---

9.5 Electrical Characteristics – RF PLL Characteristics

Test Conditions: T_A=+25°C, VDD=+5.0V

PARAMETER	CONDITIONS	MIN	TYP	MAX	UNIT
RF Channel Frequency Range		2405.35		2477.35	MHz
RF Channel spacing			2		MHz
RF I/O Impedance	ANT0,ANT1		50		ohm
Crystal Oscillator Frequency	External crystal		24		MHz

9.6 Electrical Characteristics – RF RX Characteristics

Test Conditions: T_A=+25°C, VDD=+5.0V

PARAMETER	CONDITIONS	MIN	TYP	MAX	UNIT
RF Channel Frequency Range		2405.35		2477.35	MHz
RF I/O Impedance	ANT0,ANT1		50		ohm
RX Sensitivity	3Mbps mode		-90 *b		dBm
	6Mbps mode		-87 *b		dBm
Max input signal	LNA = low gain mode, min IF gain		-10		dBm
Output harmonics	2nd harmonic, POUT = +3 dBm		-60		dBm
	3rd harmonic, POUT = +3 dBm				

*b : The sensitivity been defined with BER <= 0.002.

9.7 Electrical Characteristics – RF TX Characteristics

Test Conditions: T_A=+25°C, VDD=+5.0V

PARAMETER	CONDITIONS	MIN	TYP	MAX	UNIT
RF Channel Frequency Range		2405.35		2477.35	MHz
RF I/O Impedance	ANT0,ANT1		50		ohm
TX Output power			3		dBm
TX RF output power variation vs. frequency	Freq 2400 to 2483.5 MHz		+/-1		dB

9.8 Electrical Characteristics – Audio C/CS

PARAMETER	CONDITIONS	MIN	TYP	MAX	UNIT
Frequency Response (-3dB)	24 bit audio, subwoofer OTA sample rate	20		5K	Hz
	24 bit audio, CD OTA sample rate	20		20K	Hz
	24 bit audio, Hi OTA sample rate*c	20		40K	Hz
Gain Flatness ¹	0dB Input / Output Gain		±0.2		dB
SNR	I2S Input / Output	93		117	dB

*c: Specific version only – please contact Skyworks for more details

9.9 I²S Communication Interface Timing

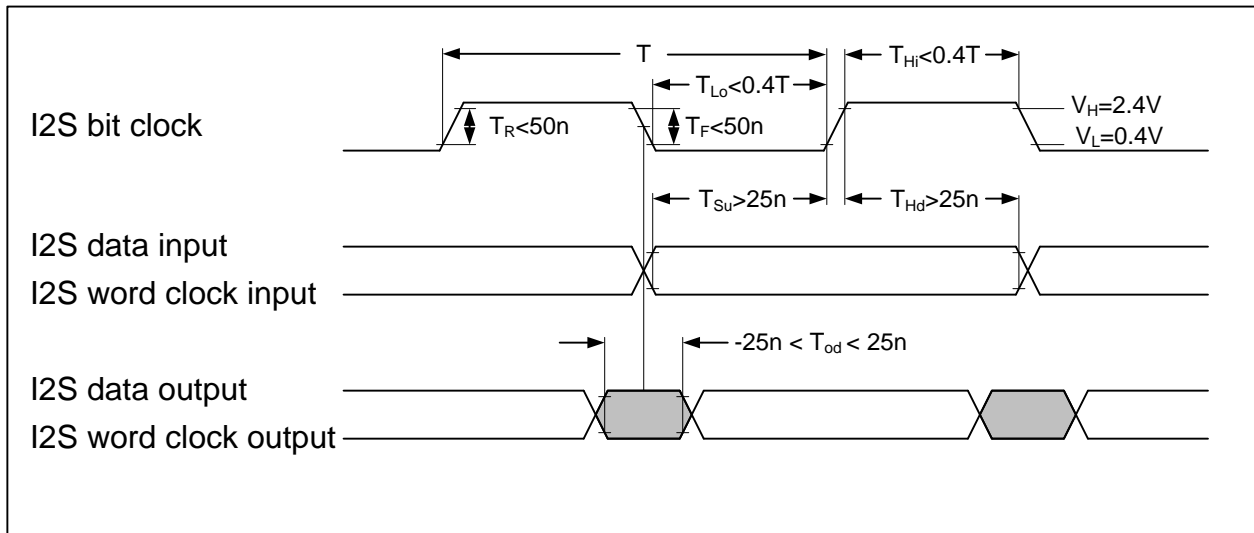
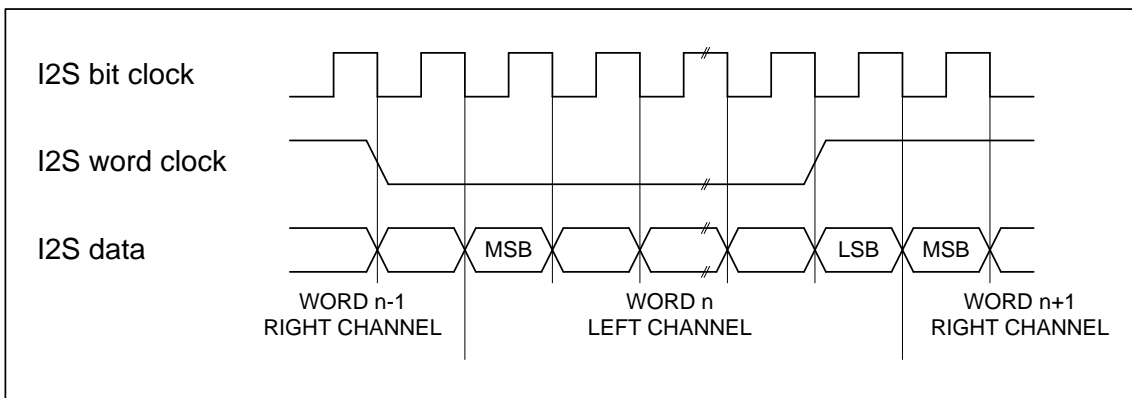

Table 2: SWA20 I2S Timing

		MIN	TYP	MAX	UNIT	NOTES
V _L	low voltage level		0.0V	0.4V	V	
V _H	high voltage level	2.4V	3.3V		V	
T	clock period		325.5n		s	1/3.072MHz
T _{Lo}	clock low period	0.4T		0.6T		
T _{Hi}	clock high period	0.4T		0.6T		
T _R	rise time			50n	s	Note 1
T _F	fall time			50n	s	Note 1
T _{Su}	setup time	25n			s	
T _{Hd}	hold time	25n			s	
T _{Od}	output delay	-25n		25n	s	
	bit clocks/word clock		64			

I2S protocol is “I2S Justified” as shown below.



Note 1: The timing specified for the rise and fall times represents the edge rates on the module itself. The rise and fall times of the I2S signals are determined by ESD/EMI mitigation components on the modules, as well as external loading, and will be higher than the specified numbers

9.10 I2C Master/Slave Communication Interface Timing (S_SCL, S_SDA)

The SWA20 has both I2C slave and master interfaces available with their respective pins S_SCL, S_SDA and M_SCL, M_SDA. The interfaces operate in I2C fast-mode and can receive and transmit at up to 400 kbit/s.

Bytes are 8 bits long and are transferred with the most significant bit (MSB) first. Each byte has to be followed by an acknowledge bit. The SWA20 will apply clock-stopping (by holding the clock line S_SCL LOW to force the master into a wait state) if necessary due to internal high-priority tasks.

The slave/master interface can be used both for writing (e.g. sending commands) or reading (e.g. requesting status). An additional GPIO pin on the SWA20 (Ex. GPIO24), can be used to notify the I2C master when a pending message is ready to be sent.

The SWA20 slave interface responds to the 7-bit slave address TBD as shown in Figure 1 below.



Figure 5: First Byte after the START Procedure

ELECTRICAL SPECIFICATIONS AND TIMING

Table 3: Characteristics of the S_SDA and S_SCL I/Os

PARAMETER	SYMBOL	FAST-MODE		UNIT
		MIN.	MAX.	
LOW level input voltage	V _{IL}	-0.3	0.7	V
HIGH level input voltage	V _{IH}	2.0	3.6	V
LOW level output voltage (open drain or open collector) at 1 mA sink current:	V _{OL}	0	0.4	V
Output fall time from V _{IHmin} to V _{ILmax} with a bus capacitance from 10 pF to 400 pF	t _{of}	0	250	ns
Pulse width of spikes which must be suppressed by the input filter	t _{SP}	0	50	ns
S_SCL clock frequency	f _{SCL}	0	400	kHz
LOW period of the S_SCL clock	t _{LOW}	1.3	–	μs
HIGH period of the S_SCL clock	t _{HIGH}	0.6	–	μs
Data hold time	t _{HD;DAT}	100	–	ns
Data set-up time	t _{SU;DAT}	100	–	ns

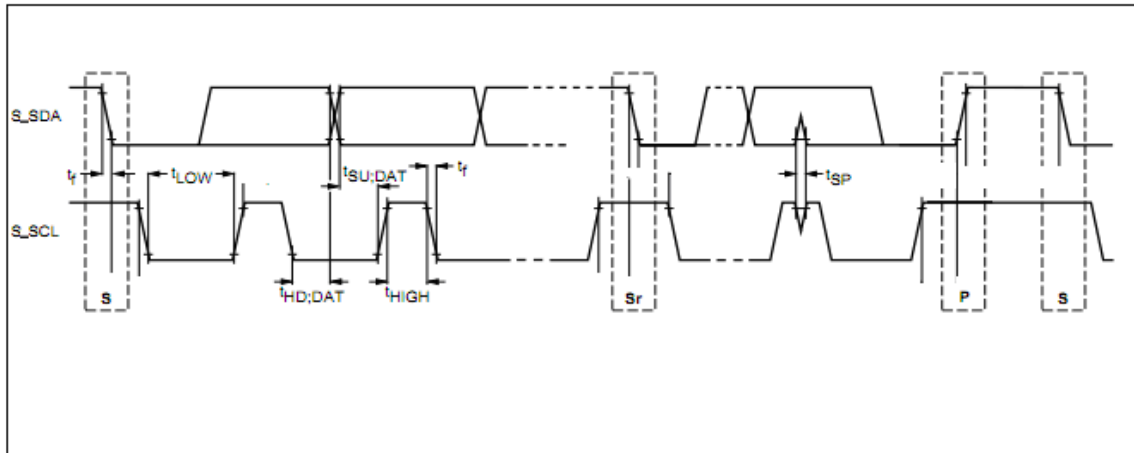

Figure 6: Definition of Timing for F/S-Mode Devices on the I²C-Bus

10 Ordering Information

Table 4: SWA20 Module Ordering Information

Module Part Number	Option Code	Description
SWA20	TX	Digital Input , FPC Connector, integrated printed PCB antennas
SWA20	RX	Digital Output, FPC Connector, integrated printed PCB antennas

11 Suggested clearance area for SWA20 printed antennas

Hereunder clearance suggestions are mainly for metal or conductive material nearby .

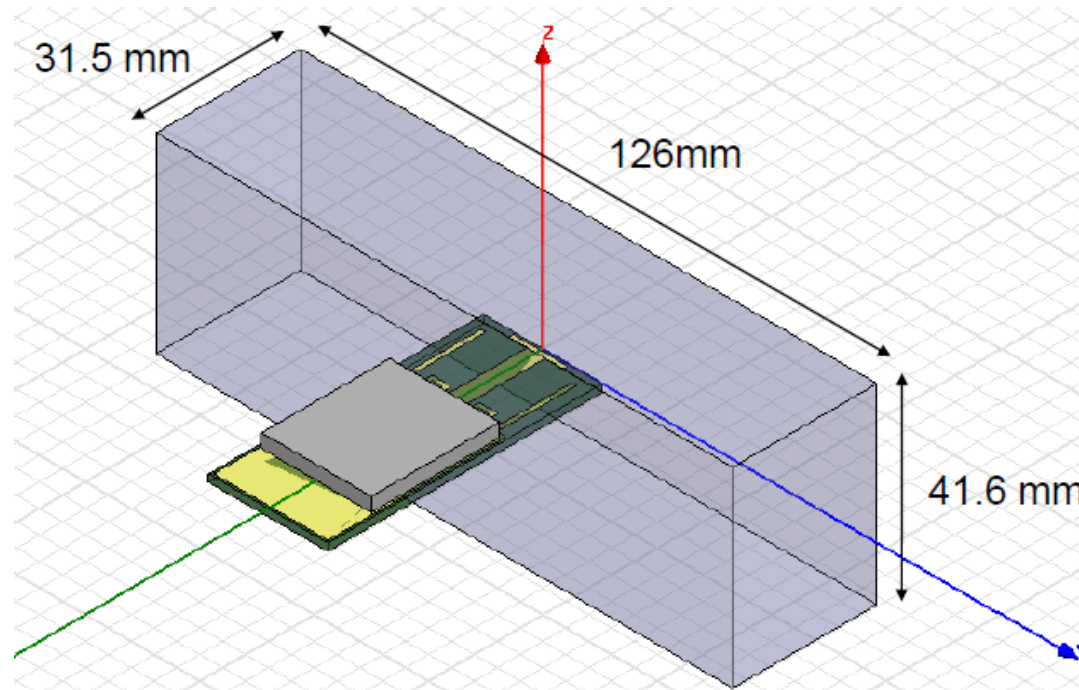

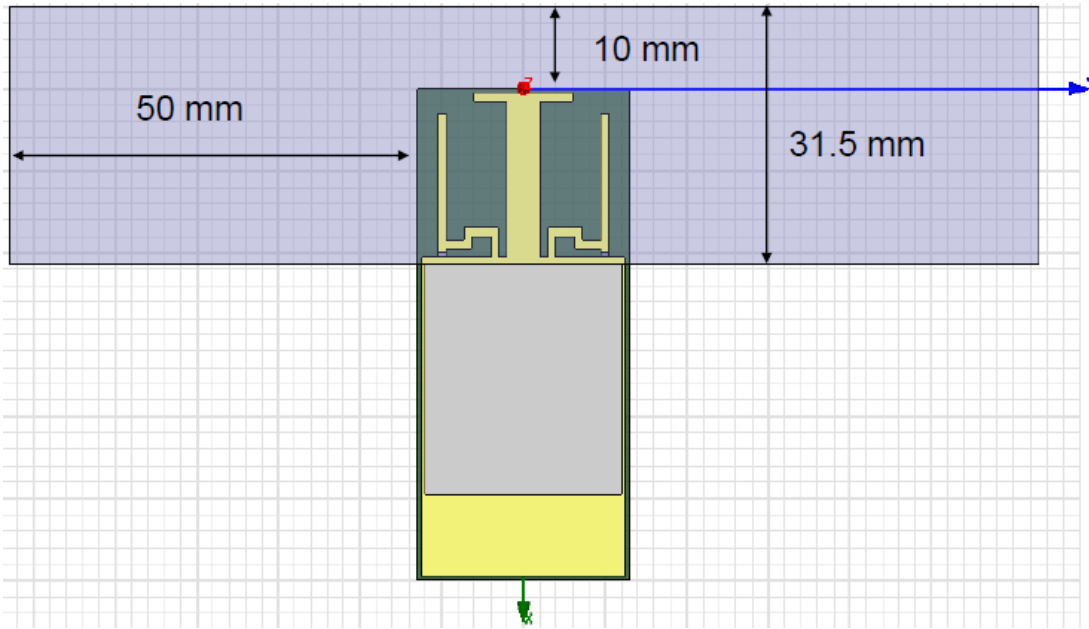

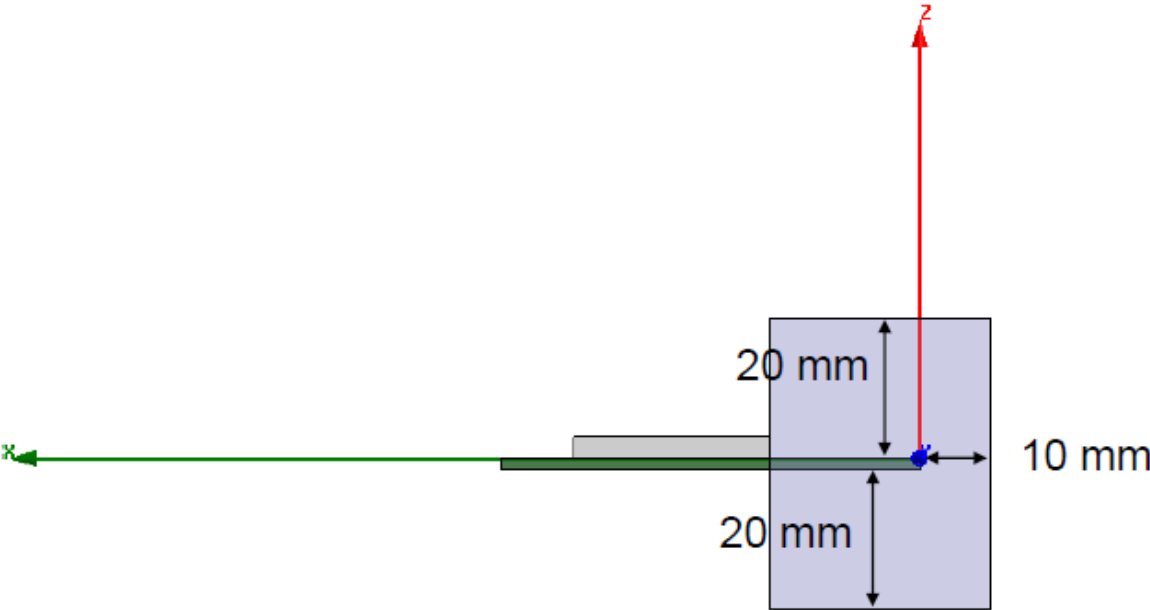

12 Precaution for Use

Be aware of the following limits before using this wireless module.

- Do NOT subject this wireless module to high temperatures, direct sunlight or moisture.
- Do NOT bend, or subject this wireless module to strong impacts.
- Do NOT disassemble or alter this wireless module in any way.
- Do NOT attempt to install this wireless module in any incompatible device.
- Do NOT remove this wireless module from product during operation.
- Data transmitted and received over radio waves may be intercepted and monitored.
- To avoid malfunctions caused by radio wave interference, please keep product away from the devices such as other wireless devices, microwave and the devices operating at 2.4GHz/5GHz when using this wireless module. Depending on the area, this wireless module may not be available.

13 FCC statement

Federal Communication Commission Interference Statement

This equipment has been tested and found to comply with the limits for a Class B digital device, pursuant to Part 15 of the FCC Rules. These limits are designed to provide reasonable protection against harmful interference in a residential installation. This equipment generates, uses and can radiate radio frequency energy and, if not installed and used in accordance with the instructions, may cause harmful interference to radio communications. However, there is no guarantee that interference will not occur in a particular installation. If this equipment does cause harmful interference to radio or television reception, which can be determined by turning the equipment off and on, the user is encouraged to try to correct the interference by one of the following measures:

- Reorient or relocate the receiving antenna.
- Increase the separation between the equipment and receiver.
- Connect the equipment into an outlet on a circuit different from that to which the receiver is connected.
- Consult the dealer or an experienced radio/TV technician for help.

CAUTION:

Any changes or modifications not expressly approved by the grantee of this device could void the user's authority to operate the equipment.

This device complies with Part 15 of the FCC Rules. Operation is subject to the following two conditions: (1) this device may not cause harmful interference, and (2) this device must accept any interference received, including interference that may cause undesired operation.

Radiation Exposure Statement:

This equipment complies with FCC radiation exposure limits set forth for an uncontrolled environment. This equipment should be installed and operated with minimum distance 20cm between the radiator & your body.

Additional testing, Part 15 Subpart B disclaimer

This transmitter module is tested as a subsystem and its certification does not cover the FCC Part 15 Subpart B (unintentional radiator) rule requirement applicable to the final host. The final host will still need to be reassessed for compliance to this portion of rule requirements if applicable.

As long as all conditions above are met, further transmitter test will not be required. However, the OEM integrator is still responsible for testing their end-product for any additional compliance requirements required with this module installed.

IMPORTANT NOTE:

In the event that these conditions can not be met (for example certain laptop configurations or co-location with another transmitter), then the FCC authorization is no longer considered valid and the FCC ID can not be used on the final product. In these circumstances, the OEM integrator will be responsible for re-evaluating the end product (including the transmitter) and obtaining a separate FCC authorization.

The host manufacturer should reference KDB Publication 996369 D04 Module Integration Guide

Manual Information To the End User

The OEM integrator has to be aware not to provide information to the end user regarding how to install or remove this RF module in the user's manual of the end product which integrates this module.

The end user manual shall include all required regulatory information/warning as show in this manual.

OEM/Host manufacturer responsibilities

OEM/Host manufacturers are ultimately responsible for the compliance of the Host and Module. The final product must be reassessed against all the essential requirements of the FCC rule such as FCC Part 15 Subpart B before it can be placed on the US market. This includes reassessing the transmitter module for compliance with the Radio and EMF essential requirements of the FCC rules. This module must not be incorporated into any other device or system without retesting for compliance as multi-radio and combined equipment

LABEL OF THE END PRODUCT:

The final end product must be labeled in a visible area with the following: "Contains FCC ID: NKR-SWA20". The grantee's FCC ID can be used only when all FCC compliance requirements are met.

14 IC Statement

Industry Canada statement

This device complies with ISED's licence-exempt RSSs. Operation is subject to the following two conditions: (1) This device may not cause harmful interference, and (2) this device must accept any interference received, including interference that may cause undesired operation.

Le présent appareil est conforme aux CNR d'ISED applicables aux appareils radio exempts de licence. L'exploitation est autorisée aux deux conditions suivantes : (1) le dispositif ne doit pas produire de brouillage préjudiciable, et (2) ce dispositif doit accepter tout brouillage reçu, y compris un brouillage susceptible de provoquer un fonctionnement indésirable.

Radiation Exposure Statement:

This equipment complies with ISED radiation exposure limits set forth for an uncontrolled environment. This equipment should be installed and operated with greater than 20m between the radiator & your body.

Déclaration d'exposition aux radiations:

Cet équipement est conforme aux limites d'exposition aux rayonnements ISED établies pour un environnement non contrôlé. Cet équipement doit être installé et utilisé à plus de 20cm entre le radiateur et votre corps.

This device is intended only for OEM integrators under the following conditions:

- 1) The antenna must be installed and operated with greater than 20m between the antenna and users
- 2) The transmitter module may not be co-located with any other transmitter or antenna.
- 3) Module approval valid only when the module is installed in the tested host or compatible series of host which have similar RF exposure characteristic with equal or larger antenna separation distance.

As long as 3 conditions above are met, further transmitter test will not be required. However, the OEM integrator is still responsible for testing their end-product for any additional compliance requirements required with this module installed.

Cet appareil est conçu uniquement pour les intégrateurs OEM dans les conditions suivantes:

- 1) L'antenne doit être installée et exploitée avec plus de 20cm entre l'antenne et les utilisateurs
- 2) Le module émetteur peut ne pas être coïmplanté avec un autre émetteur ou antenne.

3) Approbation du Module valable que lorsque le module est installé dans l'hôte testé ou de la série de l'hôte compatible qui ont même caractéristique de l'exposition aux RF avec la distance égale ou supérieure séparation antenne.

Tant que les 3 conditions ci-dessus sont remplies, des essais supplémentaires sur l'émetteur ne seront pas nécessaires. Toutefois, l'intégrateur OEM est toujours responsable des essais sur son produit final pour toutes exigences de conformité supplémentaires requis pour ce module installé.

IMPORTANT NOTE:

In the event that these conditions can not be met (for example certain laptop configurations or co-location with another transmitter), then the Canada authorization is no longer considered valid and the IC ID can not be used on the final product. In these circumstances, the OEM integrator will be responsible for re-evaluating the end product (including the transmitter) and obtaining a separate Canada authorization.

NOTE IMPORTANTE:

Dans le cas où ces conditions ne peuvent être satisfaites (par exemple pour certaines configurations d'ordinateur portable ou de certaines co-localisation avec un autre émetteur), l'autorisation du Canada n'est plus considéré comme valide et l'ID IC ne peut pas être utilisé sur le produit final. Dans ces circonstances, l'intégrateur OEM sera chargé de réévaluer le produit final (y compris l'émetteur) et l'obtention d'une autorisation distincte au Canada.

End Product Labeling

This transmitter module is authorized only for use in device where the antenna may be installed and operated with greater than 20m between the antenna and users. The final end product must be labeled in a visible area with the following: "Contains IC: 4441A-SWA20".

Plaque signalétique du produit final

Ce module émetteur est autorisé uniquement pour une utilisation dans un appareil où l'antenne peut être installée et utilisée à plus de 20cm entre l'antenne et les utilisateurs. Le produit final doit être étiqueté dans un endroit visible avec l'inscription suivante: "Contient des IC: 4441A-SWA20".

Manual Information To the End User

The OEM integrator has to be aware not to provide information to the end user regarding how to install or remove this RF module in the user's manual of the end product which integrates this module.

The end user manual shall include all required regulatory information/warning as show in this manual.

Manuel d'information à l'utilisateur final

L'intégrateur OEM doit être conscient de ne pas fournir des informations à l'utilisateur final quant à la façon d'installer ou de supprimer ce module RF dans le manuel de l'utilisateur du produit final qui intègre ce module.

Le manuel de l'utilisateur final doit inclure toutes les informations réglementaires requises et avertissements comme indiqué dans ce manuel

Caution :

(iv) where applicable, antenna type(s), antenna models(s), and worst-case tilt angle(s) necessary to remain compliant with the e.i.r.p. elevation mask requirement set forth in section 6.2.2.3 shall be clearly indicated.

Avertissement:

Le guide d'utilisation des dispositifs pour réseaux locaux doit inclure des instructions précises sur les restrictions susmentionnées, notamment :

(iv) lorsqu'il y a lieu, les types d'antennes (s'il y en a plusieurs), les numéros de modèle de l'antenne et les pires angles d'inclinaison nécessaires pour rester conforme à l'exigence de la p.i.r.e. applicable au masque d'élévation, énoncée à la section 6.2.2.3, doivent être clairement indiqués

Table for Antenna

Antenna	Brand	Model name	Connector	Gain (dBi)
1	WNC	SWA20	N/A	3.9
2	WNC	SWA20	N/A	3.5