

FCC Test Report

Product Name : Tri-band - 5G Business Internet Receiver
Brand Name : Verizon
Model No. : LV65B
FCC ID : NKR-LVPK-65

Applicant : Wistron NeWeb Corporation
Address : 20 Park Avenue II, Hsinchu Science Park,
Hsinchu 308, Taiwan

Date of Receipt : Mar. 09, 2022
Issued Date : Oct. 04, 2022
Report No. : 2280830R-RFUSWWAV07-A
Report Version : V1.0



The test results relate only to the samples tested.

The test results shown in the test report are traceable to the national/international standard through the calibration of the equipment and evaluated measurement uncertainty herein.

This report must not be used to claim product endorsement by TAF or any agency of the government.

Measurement uncertainties evaluated for each testing system and associated connections are given here to provide the system information for reference. Compliance determinations do not take into account measurement uncertainties for each testing system, but are based on the results of the compliance measurement.

The test report shall not be reproduced except in full without the written approval of DEKRA Testing and Certification Co., Ltd.



Product Name : Tri-band - 5G Business Internet Receiver
Applicant : Wistron NeWeb Corporation
Address : 20 Park Avenue II, Hsinchu Science Park, Hsinchu 308, Taiwan
Manufacturer : Wistron NeWeb Corporation
Address : 20 Park Avenue II, Hsinchu Science Park, Hsinchu 308, Taiwan
Brand Name : Verizon
Model No. : LV65B
FCC ID : NKR-LVPK-65
EUT Voltage : AC 100 ~ 120V/50-60Hz
Testing Voltage : AC 120V/60Hz
Applicable Standard : FCC CFR Title 47 Part 22 Subpart H
FCC CFR Title 47 Part 24 Subpart E
FCC CFR Title 47 Part 27 Subpart D, Subpart F, Subpart L, Subpart M
ANSI/TIA-603-E-2016
ANSI C63.26-2015
Laboratory Name : DEKRA Testing and Certification Co., Ltd.
Hsin Chu Laboratory
Address : No.372-2, Sec. 4, Zhongxing Rd., Zhudong Township, Hsinchu
County 310, Taiwan, R.O.C.
Test Result : Complied

Documented By :



(Hailey Peng / Senior Engineer)

Approved By :



(Rueyyan Lin / Supervisor)

The test results relate only to the samples tested.

The test report shall not be reproduced except in full without the written approval of DEKRA Testing and Certification Co., Ltd.

Revision History

Version	Description	Issued Date
V1.0	Initial issue of report	Oct. 04, 2022

TABLE OF CONTENTS

Description	Page
1. General Information	6
1.1. EUT Description.....	6
1.2. Mode of Operation	9
1.3. Comments and Remarks	9
1.4. Tested System Details	10
1.5. Configuration of Tested System	10
1.6. EUT Operation of during Test	10
2. Technical Test	11
2.1. Summary of Test Result.....	11
2.2. Test Environment.....	13
2.3. List of Test Equipment	15
2.4. Measurement Uncertainty.....	16
3. RF Output Power	17
3.1. Test Setup.....	17
3.2. Test Procedure	17
3.3. Test Methodology and Reference Procedures	17
3.4. Test Result of RF Output Power	18
4. Occupied Bandwidth.....	27
4.1. Test Setup.....	27
4.2. Test Procedure	27
4.3. Test Methodology and Reference Procedures	27
4.4. Test Result of Occupied Bandwidth	28
5. Peak to Average Ratio	71
5.1. Test Setup.....	71
5.2. Test Procedure	71
5.3. Test Methodology and Reference Procedures	71
5.4. Test Result of Peak to Average Ratio	72
6. Spurious Emissions	107
6.1. Test Setup.....	107
6.2. Test Procedure	109
6.3. Test Methodology and Reference Procedures	109
6.4. Test Result of Conducted Spurious Emission	110
6.5. Test Result of Radiated Spurious Emission	128
7. Conducted Band Edge.....	135

7.1. Test Setup.....	135
7.2. Test Procedure	135
7.3. Test Methodology and Reference Procedures.....	135
7.4. Test Result of Conducted Band Edge	136
8. Frequency Stability	149
8.1. Test Setup.....	149
8.2. Test Procedure	149
8.3. Test Methodology and Reference Procedures.....	149
8.4. Test Result of Frequency Stability.....	150
Appendix A.....	168
<input type="checkbox"/> Test Setup Photograph	168

1. General Information

1.1. EUT Description

Product Name	Tri-band - 5G Business Internet Receiver	
Brand Name	Verizon	
Model No.	LV65B	
Uplink Frequency Range (MHz)	LTE Band 2: 1850~1910 LTE Band 5: 824~849 LTE Band 13: 777~787 LTE Band 66: 1710~1780	
Downlink Frequency Range (MHz)	LTE Band 2: 1930~1990 LTE Band 5: 869~894 LTE Band 13: 746~756 LTE Band 66: 2110~2200	
Bandwidth (MHz)	LTE Band 2: 1.4 / 3 / 5 / 10 / 15 / 20 LTE Band 5: 1.4 / 3 / 5 / 10 LTE Band 13: 5 / 10 LTE Band 66: 1.4 / 3 / 5 / 10 / 15 / 20	
Maximum RF output power	LTE Band 2	24.07 dBm
	LTE Band 5	24.91 dBm
	LTE Band 13	24.99 dBm
	LTE Band 66	24.02 dBm
Type of Modulation	QPSK / 16QAM / 64QAM / 256QAM	
Hardware Version	0.0.5	
Software Version	0.2.10.1	
IMEI No.	35153910	

Accessories Information				
No.	Equipment Name	Brand Name	Model No.	Rating
1	PoE Adapter	DELTA	ADH-65BR H	INPUT: AC 100-120V, 50-60Hz, 2.0A OUTPUT: DC 56.0V, 1.161A, 65.02W
2	J-Pole	WNC	-	-
3	PoE Surge Protective Device	CITEL	CRMJ8-PoE-C6A	-

Antenna Information											
Ant.	Brand Name	Model No.	Type	Gain (dBi)							
				LTE				5GNR			
				Band 2	Band 5	Band 13	Band 66	n2	n5	n66	n77
0	WNC	LV65-LTE/FR1-0	PIFA	3	3	2.5	3	3	3	3	1
1	WNC	LV65-LTE/FR1-1	Monopole								
2	WNC	LV65-LTE/FR1-2	PIFA								
3	WNC	LV65-LTE/FR1-3	Monopole								

SA mode:

Band	ANT0		ANT1		ANT2		ANT3	
	TX	RX	TX	RX	TX	RX	TX	RX
LTE Band 2	-	V	V	V	-	V	-	V
LTE Band 5	V	V	-	V	-	V	-	V
LTE Band 13	V	V	-	V	-	V	-	V
LTE Band 66	-	V	V	V	-	V	-	V
5G NR n2	-	V	V	V	-	V	-	V
5G NR n5	V	V	-	V	-	V	-	V
5G NR n66	-	V	V	V	-	V	-	V
5G NR n77	-	V	-	V	V (TX1)	V	V (TX0)	V

NSA mode:

Configuration	Band	ANT0		ANT1		ANT2		ANT3	
		TX	RX	TX	RX	TX	RX	TX	RX
LTE(LB) + NR(MB)	LTE(LB)	V	V	-	V	-	V	-	V
	NR(MB)	-	V	V	V	-	V	-	V
LTE(MB) + NR(LB)	LTE(MB)	-	V	V	V	-	V	-	V
	NR(LB)	V	V	-	V	-	V	-	V
LTE(MB) + NR(MB)	LTE(MB)	-	V	V	V	-	V	-	V
	NR(MB)	V	V	-	V	-	V	-	V
LTE(LB) + NR(CB)	LTE(LB)	V	V	-	V	-	V	-	V
	NR(CB)	-	V	-	V	-	V	V	V
LTE(MB) + NR(CB)	LTE(MB)	-	V	V	V	-	V	-	V
	NR(CB)	-	V	-	V	-	V	V	V
LTE(CB) + NR(CB)	LTE(CB)	-	V	-	V	-	V	V	V
	NR(CB)	-	V	-	V	V	V	-	V

Note:

1. LB: Low-Band, means LTE B5/B13, 5G NR n5
2. MB: Mid-Band, means LTE B2/B66, 5G NR n2/n66
3. CB: C-Band, means LTE B48, 5G NR n77
4. Regarding frequency band operation, the lowest, middle and highest frequency of channel were selected to perform the test, and the details were shown on this report.
5. The EUT description is from the customer declaration.
6. The device was tested under all configurations, combinations, bandwidths, RB configurations and modulations, and the worst case was found in SA mode QPSK modulation, therefore the "Conducted Band Edge" & "Spurious Emission" test items perform SA mode QPSK modulation and shown on this test report.

1.2. Mode of Operation

DEKRA has verified the construction and function in typical operation. All the test modes were carried out with the EUT in normal operation, which was shown in this test report and defined as:

Test Mode	Mode 1: LTE Band 2 Mode 2: LTE Band 5 Mode 3: LTE Band 13 Mode 4: LTE Band 66
-----------	--

Note:

1. Determining compliance shall be based on the results of the compliance measurement, not taking into account measurement instrumentation uncertainty.
2. The product both supports the standalone and inter-carrier aggregation mode. After evaluation and comparison, the worst case is investigated in the standalone mode. Therefore, there is only displayed the test result for standalone mode in the test report.
3. The difference compared to the DEKRA Project No.: 2230313R (FCC ID: NKR-LVSK-65) is the change in SIM type, sets of LED, appearance, and size; these two devices are identical in RF hardware design, layout, circuit and antenna. After evaluation, it verified the simultaneous transmit RSE testing and the characteristics are similar to the original model, so other data references DEKRA Project No.: 2230313R (FCC ID: NKR-LVSK-65).

1.3. Comments and Remarks

The product specification and testing instructions for the EUT declared in the report are provided by the manufacturer who will take all responsibilities for the accuracy.

1.4. Tested System Details

The types for all equipment, plus descriptions of all cables used in the tested system.

	Product	Manufacturer	Model No.	Serial No.
1	Base Station	Anritsu	MT8821	62619115489
2	Horn Antenna	Schwarzbeck	BBHA 9120D	1640

1.5. Configuration of Tested System

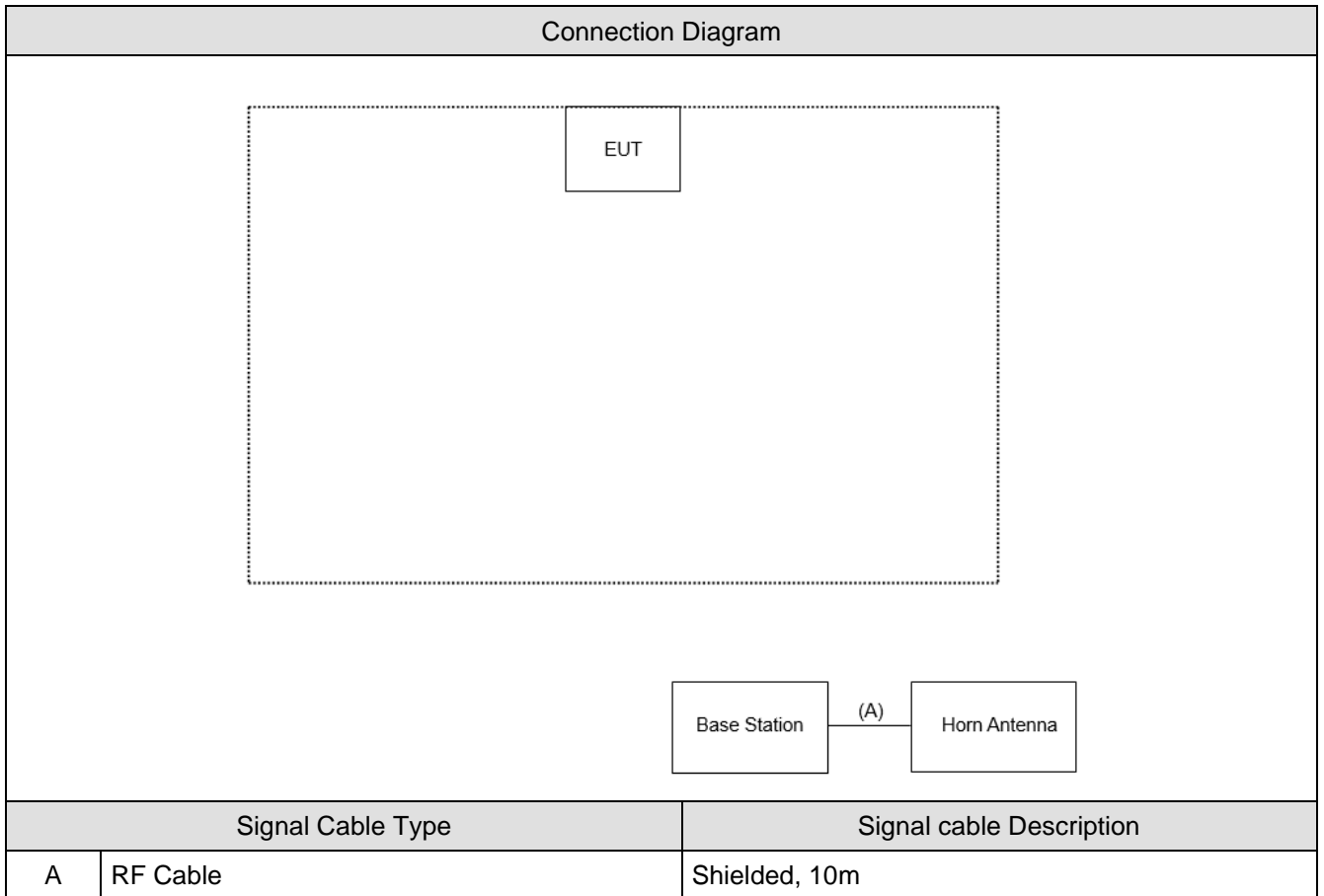

1.6. EUT Operation of during Test

1	Set the EUT as shown.
2	EUT is connected through the base station
3	Configure test mode, test channel and data rate.
4	Let the EUT start sending continuously.
5	Verify that the device is working properly.

2. Technical Test

2.1. Summary of Test Result

- No deviations from the test standards
 Deviations from the test standards as below description:

LTE Band 2			
FCC Part 24 Subpart E			
Performed Item	FCC Reference Section	Limit	Result
RF Output Power	§2.1033	< 2 Watts	Pass
	§2.1046		
	§24.232		
Occupied Bandwidth	§2.1049	N/A	Pass
Peak to Average Ratio	§24.232(d)	\leq 13 dB	Pass
Conducted Band Edge	§24.238	< -13 dBm	Pass
Spurious Emission	§2.1053	< -13 dBm	Pass
	§24.238		
Frequency Stability	§2.1055	\pm 2.5 ppm	Pass
	§24.235		

Note: Determining compliance shall be based on the results of the compliance measurement, not taking into account measurement instrumentation uncertainty.

LTE Band 5			
FCC Part 22 Subpart H			
Performed Item	FCC Reference Section	Limit	Result
RF Output Power	§2.1033	< 7 Watts	Pass
	§2.1046		
	§22.913		
Occupied Bandwidth	§2.1049	N/A	Pass
Peak to Average Ratio	§22.913	\leq 13 dB	Pass
Conducted Band Edge	§2.1053	< -13 dBm	Pass
	§22.917		
Spurious Emission	§22.917	< -13 dBm	Pass
Frequency Stability	§2.1055	\pm 2.5 ppm	Pass
	§22.335		

Note: Determining compliance shall be based on the results of the compliance measurement, not taking into account measurement instrumentation uncertainty.

LTE Band 13			
FCC Part 27 Subpart F			
Performed Item	FCC Reference Section	Limit	Result
RF Output Power	§2.1033	< 3 Watts ERP	Pass
	§2.1046		
	§27.50		
Occupied Bandwidth	§2.1049	N/A	Pass
Peak to Average Ratio	§27.50	< -13 dB	Pass
Conducted Band Edge	§2.1053	< -13 dBm < -35 dBm (763-775 MHz & 793-805 MHz)	Pass
	§27.53		
Spurious Emission	§27.53	< -13 dBm < -70 dBW/MHz e.i.r.p. of all emissions, including harmonics in the band 1559-1610 MHz	Pass
Frequency Stability	§2.1055	± 2.5 ppm	Pass
	§27.54		

Note: Determining compliance shall be based on the results of the compliance measurement, not taking into account measurement instrumentation uncertainty.

LTE Band 66			
FCC Part 27 Subpart L			
Performed Item	FCC Reference Section	Limit	Result
RF Output Power	§2.1033	< 1 Watts	Pass
	§2.1046		
	§27.50		
Occupied Bandwidth	§2.1049	N/A	Pass
Peak to Average Ratio	§27.50	< 13 dB	Pass
Conducted Band Edge	§2.1053	< -13 dBm	Pass
	§27.53		
Spurious Emission	§27.53	< -13 dBm	Pass
Frequency Stability	§2.1055	± 2.5 ppm	Pass
	§27.54		

Note: Determining compliance shall be based on the results of the compliance measurement, not taking into account measurement instrumentation uncertainty.

2.2. Test Environment

Ambient conditions in the laboratory:

Items	Test Item	Actually	Tested by	Test Date	Test Site
Temperature (°C)	RF Output Power	23	Getaz Yang	2022/03/23	HC-SR12
Humidity (%RH)		64			
Temperature (°C)	Occupied Bandwidth	24	Max Chang	2022/04/11	HC-SR12
Humidity (%RH)		63			
Temperature (°C)	Peak to Average Ratio	21	Max Chang	2022/04/01	HC-SR12
Humidity (%RH)		60			
Temperature (°C)	Conducted Band Edge	25	Max Chang	2022/04/12	HC-SR12
Humidity (%RH)		63			
Temperature (°C)	Conducted Spurious Emission	24	Max Chang	2022/04/13	HC-SR12
Humidity (%RH)		61			
Temperature (°C)	Radiated Spurious Emission	23.5	Ling Chen	2022/04/21	HC-CB02
Humidity (%RH)		63			
Temperature (°C)	Frequency Stability	23	Max Chang	2022/04/14	HC-SR12
Humidity (%RH)		65			

Note: Test site information refers to Laboratory Information.

Laboratory Information

USA : FCC Registration Number: TW3024

Canada CAB identifier : TW3024

The address and introduction of DEKRA Testing and Certification Co., Ltd. laboratories can be founded in our

Web site: <http://www.dekra.com.tw>

If you have any comments, please don't hesitate to contact us. Our test sites as below:

Test Laboratory	DEKRA Testing and Certification Co., Ltd.
Address	<ol style="list-style-type: none"> No.372-2, Sec. 4, Zhongxing Rd., Zhudong Township, Hsinchu County 31061, Taiwan, R.O.C. No.372, Sec. 4, Zhongxing Rd., Zhudong Township, Hsinchu County 31061, Taiwan, R.O.C.
Phone number	<ol style="list-style-type: none"> +886-3-582-8001 +886-3-582-8001
Fax number	<ol style="list-style-type: none"> +886-3-582-8958 +886-3-582-8958
E mail address	info.tw@dekra.com
Website	http://www.dekra.com.tw
<p>Note: Test site for address 1 includes HC-SR02. Test site for address 2 includes HC-CB02, HC-CB03, HC-CB04, HC-SR10 and HC-SR12.</p>	

2.3. List of Test Equipment

HC-SR12

Instrument	Manufacturer	Model No.	Serial No.	Cal. Date	Next Cal. Date
High Speed Peak Power Meter Dual Input	Anritsu	ML2496A	1602004	2021/11/12	2022/11/11
Pulse Power Sensor	Anritsu	MA2411B	1531043	2021/11/12	2022/11/11
EXA Signal Analyzer	Keysight	N9010A	MY51440132	2022/01/07	2023/01/06
Pulse Power Sensor	Anritsu	MA2411B	1531044	2021/11/12	2022/11/11
Spectrum Analyzer	Keysight	N9010B	MY57110159	2022/03/15	2023/03/14
Radio Communication Tester	Anritsu	MT8821C	6261915489	2021/11/26	2022/11/25
Spectrum Analyzer	Agilent	N9010A	US47140172	2021/05/28	2022/05/27
Signal Analyzer	R&S	FSVA40	101455	2021/10/22	2022/10/21
Temperature & Humidity Test Chamber	KSON	THS-B4T-150	A0401	2021/12/16	2022/12/15

HC-CB02

Instrument	Manufacturer	Model No.	Serial No.	Cal. Date	Next Cal. Date
Signal Analyzer	R&S	FSVA40	101435	2021/06/04	2022/06/03
EXA Signal Analyzer	Keysight	N9010A	MY51440132	2022/01/07	2023/01/06
Trilog Broadband Antenna	Schwarzbeck	VULB 9168	1209	2021/05/28	2022/05/27
Horn Antenna	Schwarzbeck	BBHA 9120D	639	2021/05/17	2022/05/16
Horn Antenna	Schwarzbeck	BBHA 9170	202	2021/12/01	2022/11/30
Pre-Amplifier	EMCI	EMC01820I	980364	2021/08/27	2022/08/26
Pre-Amplifier	EMEC	EM01G18GA	060741	2021/07/02	2022/07/01
Pre-Amplifier	DEKRA	AP-400C	201801231	2021/12/24	2022/12/23
Radio Communication Tester	Anritsu	MT8821C	6261915489	2021/11/26	2022/11/25
Coaxial Cable(13m)	Huber+Suhner	SF104	HC-CB02	2021/08/17	2022/08/16
Coaxial Cable(3m)	Suhner,Rosnol	SF102_Rosnol	HC-CB02	2021/08/17	2022/08/18
Radiated Software	AUDIX	e3 V9	HC-CB02	N/A	N/A

Note: All equipment upon which need to calibrated are with calibration period of 1 year.

2.4. Measurement Uncertainty

Uncertainties have been calculated according to the DEKRA internal document with the emissions test results be included in the report. The measurement uncertainties given below are based on a 95% confidence level (based on a coverage factor (k=2)).

Test Item	Uncertainty
RF Output Power	± 1.16 dB
Occupied Bandwidth	± 217.9 Hz
Peak to Average Ratio	± 1.16 dB
Conducted Band Edge	± 1.16 dB
Spurious Emissions	± 3.25 dB below 1 GHz ± 3.32 dB above 1 GHz
Frequency Stability	± 217.9 Hz

3. RF Output Power

3.1. Test Setup

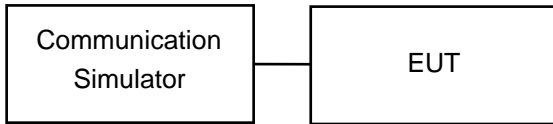

3.2. Test Procedure

The EUT makes a call to the communication simulator. The communication simulator station system controlled a EUT to export maximum conducted RF output power under transmission mode and specific channel frequency. The relevant equation for determining the ERP or EIRP from the conducted RF output power measured using the guidance provided above is:

$$\text{ERP or EIRP} = P_{\text{Meas}} + G_{\text{T}} - L_{\text{C}}$$

where:

ERP or EIRP = effective radiated power or equivalent isotropically radiated power, respectively (expressed in the same units as P_{Meas} , typically dBW or dBm);

P_{Meas} = measured transmitter output power or PSD, in dBm or dBW;

G_{T} = gain of the transmitting antenna, in dBd (ERP) or dBi (EIRP);

L_{C} = signal attenuation in the connecting cable between the transmitter and antenna, in dB

3.3. Test Methodology and Reference Procedures

KDB 971168 D01 Power Meas License Digital Systems v03r01

ANSI C63.26-2015

3.4. Test Result of RF Output Power

Mode 1: LTE Band 2

Mode					Conducted Power				EIRP Power				Limit
BW (MHz)	Channel	Frequency (MHz)	RB No.	RB offset	QPSK (dBm)	16-QAM (dBm)	64-QAM (dBm)	256-QAM (dBm)	QPSK EIRP(W)	16-QAM EIRP(W)	64-QAM EIRP(W)	256-QAM EIRP(W)	Limit EIRP(W)
1.4	18607	1850.7	1	0	23.83	23.39	22.50	20.70	0.482	0.436	0.355	0.234	2
				2	23.90	23.15	21.91	20.87	0.490	0.412	0.310	0.244	2
			6	5	23.70	23.13	21.82	20.75	0.468	0.410	0.303	0.237	2
				0	22.91	21.93	20.78	19.97	0.390	0.311	0.239	0.198	2
	18900	1880	1	0	23.92	23.37	21.98	20.94	0.492	0.434	0.315	0.248	2
				2	23.73	23.19	21.83	20.79	0.471	0.416	0.304	0.239	2
			6	5	23.65	22.70	21.66	20.77	0.462	0.372	0.292	0.238	2
				0	22.81	21.92	20.92	19.89	0.381	0.310	0.247	0.195	2
	19193	1909.3	1	0	23.74	22.97	21.52	20.86	0.472	0.395	0.283	0.243	2
				2	23.68	22.98	21.78	20.54	0.466	0.396	0.301	0.226	2
			6	5	23.56	23.12	21.80	20.47	0.453	0.409	0.302	0.222	2
				0	22.69	21.65	20.54	19.49	0.371	0.292	0.226	0.177	2
3	18615	1851.5	1	0	23.93	23.47	21.74	20.82	0.493	0.444	0.298	0.241	2
				7	24.00	22.82	21.91	21.09	0.501	0.382	0.310	0.256	2
			15	14	23.79	22.89	21.65	20.64	0.478	0.388	0.292	0.231	2
				0	22.88	22.01	20.94	19.98	0.387	0.317	0.248	0.199	2
	18900	1880	1	0	23.85	22.90	22.12	20.92	0.484	0.389	0.325	0.247	2
				7	23.77	23.03	21.75	20.79	0.475	0.401	0.299	0.239	2
			15	14	23.43	23.12	21.68	20.25	0.440	0.409	0.294	0.211	2
				0	22.86	21.65	20.75	20.01	0.385	0.292	0.237	0.200	2
	19185	1908.5	1	0	23.66	23.24	21.80	20.81	0.463	0.421	0.302	0.240	2
				7	23.80	23.28	21.86	20.92	0.479	0.425	0.306	0.247	2
			15	14	23.59	22.88	21.79	20.53	0.456	0.387	0.301	0.225	2
				0	22.74	21.75	20.75	19.82	0.375	0.299	0.237	0.191	2

Note:

1. RF Output Power (W) EIRP = Conducted Output Power (dBm) + Antenna Gain (dBi)

2. Power (W) = $(10^{(Power(dBm)/10)}) * 10^{-3}$

Mode				Conducted Power				EIRP Power				Limit	
BW (MHz)	Channel	Frequency (MHz)	RB No.	RB offset	QPSK (dBm)	16-QAM (dBm)	64-QAM (dBm)	256-QAM (dBm)	QPSK EIRP(W)	16-QAM EIRP(W)	64-QAM EIRP(W)	256-QAM EIRP(W)	Limit EIRP(W)
5	18625	1852.5	1	0	23.92	22.96	22.69	20.75	0.492	0.394	0.371	0.237	2
				12	23.92	23.52	21.89	21.08	0.492	0.449	0.308	0.256	2
				24	23.85	22.93	21.89	20.82	0.484	0.392	0.308	0.241	2
			25	0	22.93	21.92	20.97	19.77	0.392	0.310	0.249	0.189	2
	18900	1880	1	0	23.81	23.27	21.49	20.86	0.480	0.424	0.281	0.243	2
				12	23.90	23.01	21.97	20.94	0.490	0.399	0.314	0.248	2
				24	23.78	22.88	21.99	20.94	0.476	0.387	0.316	0.248	2
			25	0	22.80	21.84	20.85	19.84	0.380	0.305	0.243	0.192	2
	19175	1907.5	1	0	23.66	22.95	21.80	20.65	0.463	0.394	0.302	0.232	2
				12	23.93	23.10	21.62	20.75	0.493	0.407	0.290	0.237	2
				24	23.75	22.72	21.99	20.75	0.473	0.373	0.316	0.237	2
			25	0	22.71	21.61	20.58	19.71	0.372	0.289	0.228	0.187	2
10	18650	1855	1	0	23.88	23.47	22.24	20.76	0.488	0.444	0.334	0.238	2
				24	23.93	23.56	22.21	20.86	0.493	0.453	0.332	0.243	2
				49	23.88	22.85	21.98	20.77	0.488	0.385	0.315	0.238	2
			50	0	22.95	21.97	20.99	19.85	0.394	0.314	0.251	0.193	2
	18900	1880	1	0	23.66	23.10	21.96	20.51	0.463	0.407	0.313	0.224	2
				24	23.64	22.97	22.12	20.57	0.461	0.395	0.325	0.228	2
				49	23.80	22.93	21.89	20.94	0.479	0.392	0.308	0.248	2
			50	0	22.83	21.77	20.87	19.95	0.383	0.300	0.244	0.197	2
	19150	1905	1	0	23.67	22.57	21.46	20.51	0.465	0.361	0.279	0.224	2
				24	23.92	22.90	21.73	20.75	0.492	0.389	0.297	0.237	2
				49	23.59	23.13	21.88	20.41	0.456	0.410	0.308	0.219	2
			50	0	22.82	21.78	20.81	19.65	0.382	0.301	0.240	0.184	2

Note:

1. RF Output Power (W) EIRP = Conducted Output Power (dBm) + Antenna Gain (dBi)

2. Power (W)= $(10^{(Power(dBm)/10)}) * 10^{-3}$

Mode					Conducted Power				EIRP Power				Limit
BW (MHz)	Channel	Frequency (MHz)	RB No.	RB offset	QPSK (dBm)	16-QAM (dBm)	64-QAM (dBm)	256-QAM (dBm)	QPSK EIRP(W)	16-QAM EIRP(W)	64-QAM EIRP(W)	256-QAM EIRP(W)	Limit EIRP(W)
15	18675	1857.5	1	0	23.77	22.77	21.89	20.74	0.475	0.378	0.308	0.237	2
				37	23.68	22.77	22.27	20.57	0.466	0.378	0.337	0.228	2
				74	23.58	22.96	21.90	20.74	0.455	0.394	0.309	0.237	2
			75	0	22.81	21.75	20.80	19.68	0.381	0.299	0.240	0.185	2
	18900	1880	1	0	23.81	23.25	21.72	20.72	0.480	0.422	0.296	0.236	2
				37	23.49	23.05	21.92	20.60	0.446	0.403	0.310	0.229	2
				74	23.49	23.25	21.72	20.37	0.446	0.422	0.296	0.217	2
			75	0	22.73	21.73	20.69	19.68	0.374	0.297	0.234	0.185	2
	19125	1902.5	1	0	23.53	22.73	21.85	20.71	0.450	0.374	0.305	0.235	2
				37	23.93	22.85	21.95	20.88	0.493	0.385	0.313	0.244	2
				74	23.54	22.69	21.58	20.55	0.451	0.371	0.287	0.226	2
			75	0	22.71	21.63	20.62	19.84	0.372	0.290	0.230	0.192	2
20	18700	1860	1	0	24.07	23.72	22.71	21.11	0.509	0.470	0.372	0.258	2
				49	23.97	23.39	21.85	20.95	0.498	0.436	0.305	0.248	2
				99	23.76	22.77	21.78	20.90	0.474	0.378	0.301	0.245	2
			100	0	22.88	21.85	20.88	20.03	0.387	0.305	0.244	0.201	2
	18900	1880	1	0	23.66	22.49	22.10	20.72	0.463	0.354	0.324	0.236	2
				49	23.63	22.74	21.87	20.43	0.460	0.375	0.307	0.220	2
				99	23.66	23.10	21.97	20.83	0.463	0.407	0.314	0.242	2
			100	0	22.67	21.75	20.63	19.83	0.369	0.299	0.231	0.192	2
	19100	1900	1	0	23.40	23.23	21.70	20.28	0.437	0.420	0.295	0.213	2
				49	23.84	23.51	22.18	20.94	0.483	0.448	0.330	0.248	2
				99	23.71	22.58	21.61	20.85	0.469	0.361	0.289	0.243	2
			100	0	22.59	21.57	20.62	19.66	0.362	0.286	0.230	0.185	2

Note:

1. RF Output Power (W) EIRP = Conducted Output Power (dBm) + Antenna Gain (dBi)
2. Power (W)= $(10^{(Power(dBm)/10)}) * 10^{-3}$

Mode 2: LTE Band 5

Mode					Conducted Power				ERP Power				Limit
BW (MHz)	Channel	Frequency (MHz)	RB No.	RB offset	QPSK (dBm)	16-QAM (dBm)	64-QAM (dBm)	256-QAM (dBm)	QPSK ERP(W)	16-QAM ERP(W)	64-QAM ERP(W)	256-QAM ERP(W)	Limit ERP(W)
1.4	20407	824.7	1	0	24.46	23.44	22.80	21.65	0.340	0.269	0.232	0.178	7
				2	24.58	23.51	22.37	21.74	0.349	0.273	0.210	0.182	7
				5	24.47	23.51	22.93	21.37	0.340	0.273	0.239	0.167	7
			6	0	23.54	22.57	21.57	20.49	0.275	0.220	0.175	0.136	7
	20525	836.5	1	0	24.80	23.91	23.13	21.73	0.367	0.299	0.250	0.181	7
				2	24.89	24.08	22.53	21.76	0.375	0.311	0.218	0.182	7
				5	24.73	23.77	22.70	21.58	0.361	0.290	0.226	0.175	7
			6	0	23.84	22.84	21.74	20.90	0.294	0.234	0.182	0.150	7
	20643	848.3	1	0	24.11	23.37	22.09	21.44	0.313	0.264	0.197	0.169	7
				2	24.01	23.27	22.40	20.94	0.306	0.258	0.211	0.151	7
				5	23.94	23.30	21.99	20.80	0.301	0.260	0.192	0.146	7
			6	0	23.02	22.18	20.93	20.28	0.244	0.201	0.151	0.130	7
3	20415	825.5	1	0	24.50	23.98	22.87	21.31	0.343	0.304	0.236	0.164	7
				7	24.49	23.77	22.68	21.70	0.342	0.290	0.225	0.180	7
				14	24.28	23.44	22.51	21.24	0.326	0.269	0.217	0.162	7
			15	0	23.56	22.51	21.50	20.74	0.276	0.217	0.172	0.144	7
	20525	836.5	1	0	24.86	24.11	23.01	21.84	0.372	0.313	0.243	0.186	7
				7	24.75	23.98	22.77	22.13	0.363	0.304	0.230	0.199	7
				14	24.78	24.10	23.04	21.80	0.366	0.313	0.245	0.184	7
			15	0	23.84	22.94	21.77	20.94	0.294	0.239	0.183	0.151	7
	20635	847.5	1	0	24.44	23.70	22.91	21.58	0.338	0.285	0.238	0.175	7
				7	24.22	23.54	22.33	21.36	0.321	0.275	0.208	0.166	7
				14	23.86	22.73	21.63	20.84	0.296	0.228	0.177	0.148	7
			15	0	23.23	22.23	21.24	20.08	0.256	0.203	0.162	0.124	7

Note:

1. RF Output Power (W) ERP = Conducted Output Power (dBm) + Antenna Gain (dBi) - 2.15 dB

2. Power (W) = $(10^{(\text{Power(dBm)}/10)}) * 10^{-3}$

Mode		Conducted Power							ERP Power				Limit
BW (MHz)	Channel	Frequency (MHz)	RB No.	RB offset	QPSK (dBm)	16-QAM (dBm)	64-QAM (dBm)	256-QAM (dBm)	QPSK ERP(W)	16-QAM ERP(W)	64-QAM ERP(W)	256-QAM ERP(W)	Limit ERP(W)
5	20425	825.6	1	0	24.41	23.74	22.70	21.32	0.336	0.288	0.226	0.165	7
				12	24.43	23.71	22.62	21.27	0.337	0.286	0.222	0.163	7
				24	24.21	23.34	22.81	21.38	0.321	0.262	0.232	0.167	7
			25	0	23.49	22.44	21.42	20.50	0.272	0.213	0.169	0.136	7
	20525	836.5	1	0	24.85	24.18	22.84	22.07	0.372	0.318	0.234	0.196	7
				12	24.82	24.14	22.81	21.82	0.369	0.316	0.232	0.185	7
				24	24.71	23.81	22.96	21.64	0.360	0.292	0.240	0.177	7
			25	0	23.85	22.86	21.83	21.34	0.295	0.235	0.185	0.166	7
	20625	846.5	1	0	24.71	24.11	23.05	22.08	0.360	0.313	0.245	0.196	7
				12	24.37	23.50	22.49	21.49	0.333	0.272	0.216	0.171	7
				24	23.97	22.60	22.15	20.90	0.303	0.221	0.200	0.150	7
			25	0	23.49	22.53	21.43	20.40	0.272	0.218	0.169	0.133	7
10	20450	829	1	0	24.46	23.52	22.51	21.70	0.340	0.274	0.217	0.180	7
				24	24.18	23.35	22.23	21.65	0.318	0.263	0.203	0.178	7
				49	24.74	23.84	22.85	21.84	0.362	0.294	0.234	0.186	7
			50	0	23.26	22.27	21.23	20.15	0.258	0.205	0.161	0.126	7
	20525	836.5	1	0	24.91	24.22	23.16	22.15	0.377	0.321	0.252	0.200	7
				24	24.84	24.07	23.08	21.81	0.371	0.310	0.247	0.185	7
				49	24.70	23.98	22.90	22.02	0.359	0.304	0.237	0.194	7
			50	0	23.85	22.85	21.80	20.75	0.295	0.234	0.184	0.145	7
	20600	844	1	0	24.80	24.13	23.08	21.77	0.367	0.315	0.247	0.183	7
				24	24.76	24.00	23.13	22.02	0.364	0.305	0.250	0.194	7
				49	23.81	22.63	22.12	20.90	0.292	0.223	0.198	0.150	7
			50	0	23.75	22.80	21.72	20.65	0.288	0.232	0.181	0.141	7

Note:

1. RF Output Power (W) ERP = Conducted Output Power (dBm) + Antenna Gain (dBi) - 2.15 dB
2. Power (W) = $(10^{(\text{Power(dBm)/10})}) * 10^{-3}$

Mode 3: LTE Band 13

Mode					Conducted Power				ERP Power				Limit
BW (MHz)	Channel	Frequency (MHz)	RB No.	RB offset	QPSK (dBm)	16-QAM (dBm)	64-QAM (dBm)	256-QAM (dBm)	QPSK ERP(W)	16-QAM ERP(W)	64-QAM ERP(W)	256-QAM ERP(W)	Limit ERP(W)
5	23205	779.5	1	0	24.83	23.83	23.13	21.92	0.330	0.262	0.223	0.169	3
				12	24.62	23.95	23.11	21.99	0.314	0.269	0.222	0.171	3
				24	24.14	24.43	23.65	22.10	0.281	0.301	0.251	0.176	3
			25	0	23.97	22.96	21.96	20.92	0.270	0.214	0.170	0.134	3
	23230	782	1	0	24.55	23.80	22.91	22.05	0.309	0.260	0.212	0.174	3
				12	24.39	24.58	23.19	22.74	0.298	0.311	0.226	0.204	3
				24	24.42	24.41	23.67	22.85	0.300	0.299	0.252	0.209	3
			25	0	24.19	23.37	22.35	21.64	0.284	0.236	0.186	0.158	3
	23255	784.5	1	0	24.25	24.53	23.44	22.29	0.288	0.308	0.239	0.184	3
				12	24.60	24.60	23.93	22.82	0.313	0.313	0.268	0.207	3
				24	24.73	23.89	22.68	21.98	0.322	0.265	0.201	0.171	3
			25	0	24.38	23.31	22.47	21.61	0.297	0.232	0.191	0.157	3
10	23230	782	1	0	24.99	24.69	24.02	22.95	0.342	0.319	0.274	0.214	3
				24	24.34	24.51	23.47	22.70	0.294	0.306	0.241	0.202	3
				49	24.79	24.11	22.83	21.60	0.327	0.279	0.208	0.157	3
			50	0	24.38	23.32	22.46	21.77	0.297	0.233	0.191	0.163	3

Note:

1. RF Output Power (W) ERP = Conducted Output Power (dBm) + Antenna Gain (dBi) - 2.15 dB
2. Power (W) = $(10^{(\text{Power(dBm)}/10)}) * 10^{-3}$

Mode 4: LTE Band 66

Mode				Conducted Power					EIRP Power				Limit
BW (MHz)	Channel	Frequency (MHz)	RB No.	RB offset	QPSK (dBm)	16-QAM (dBm)	64-QAM (dBm)	256-QAM (dBm)	QPSK EIRP(W)	16-QAM EIRP(W)	64-QAM EIRP(W)	256-QAM EIRP(W)	Limit EIRP(W)
1.4	131979	1710.7	1	0	23.62	22.64	21.34	20.48	0.459	0.366	0.272	0.223	1
				2	23.51	22.88	21.60	20.52	0.448	0.387	0.288	0.225	1
				5	23.51	22.66	21.60	20.69	0.448	0.368	0.288	0.234	1
			6	0	22.52	21.72	20.52	19.45	0.356	0.296	0.225	0.176	1
	132322	1745	1	0	23.63	23.39	22.22	20.78	0.460	0.436	0.333	0.239	1
				2	23.71	23.04	21.97	20.60	0.469	0.402	0.314	0.229	1
				5	23.77	23.58	21.92	20.77	0.475	0.455	0.310	0.238	1
			6	0	22.92	21.94	20.89	19.91	0.391	0.312	0.245	0.195	1
	132665	1779.3	1	0	23.77	22.94	21.83	20.72	0.475	0.393	0.304	0.236	1
				2	23.73	23.36	21.67	20.59	0.471	0.433	0.293	0.229	1
				5	23.76	23.08	21.76	20.59	0.474	0.406	0.299	0.229	1
			6	0	22.76	21.75	21.00	19.61	0.377	0.299	0.251	0.182	1
3	131987	1711.5	1	0	23.50	22.68	21.39	20.41	0.447	0.370	0.275	0.219	1
				7	23.49	22.74	21.54	20.68	0.446	0.375	0.284	0.233	1
				14	23.44	22.85	21.64	20.43	0.441	0.385	0.291	0.220	1
			15	0	22.59	21.57	20.63	19.39	0.362	0.286	0.231	0.173	1
	132322	1745	1	0	23.62	22.91	22.15	20.57	0.459	0.390	0.327	0.228	1
				7	23.81	23.47	21.63	20.78	0.480	0.444	0.290	0.239	1
				14	23.78	22.89	22.14	20.76	0.476	0.388	0.327	0.238	1
			15	0	22.74	21.70	20.81	19.58	0.375	0.295	0.240	0.181	1
	132657	1778.5	1	0	23.66	23.03	21.76	20.53	0.463	0.401	0.299	0.225	1
				7	23.88	23.05	21.55	21.02	0.488	0.403	0.285	0.252	1
				14	23.60	23.02	21.81	20.49	0.457	0.400	0.303	0.223	1
			15	0	22.72	21.83	20.74	19.64	0.373	0.304	0.237	0.184	1

Note:

1. RF Output Power (W) EIRP = Conducted Output Power (dBm) + Antenna Gain (dBi)

2. Power (W) = $(10^{(\text{Power(dBm)}/10)}) * 10^{-3}$

Mode					Conducted Power				EIRP Power				Limit
BW (MHz)	Channel	Frequency (MHz)	RB No.	RB offset	QPSK (dBm)	16-QAM (dBm)	64-QAM (dBm)	256-QAM (dBm)	QPSK EIRP(W)	16-QAM EIRP(W)	64-QAM EIRP(W)	256-QAM EIRP(W)	Limit EIRP(W)
5	131997	1712.5	1	0	23.52	22.86	21.60	20.49	0.449	0.385	0.288	0.223	1
				12	23.68	23.14	21.94	20.63	0.466	0.411	0.312	0.231	1
				24	23.43	22.70	21.98	20.49	0.440	0.372	0.315	0.223	1
			25	0	22.60	21.67	20.59	19.66	0.363	0.293	0.229	0.185	1
	132322	1745	1	0	23.85	22.75	21.97	20.72	0.484	0.376	0.314	0.236	1
				12	23.85	22.93	22.50	20.89	0.484	0.392	0.355	0.245	1
				24	23.84	23.03	22.16	20.99	0.483	0.401	0.328	0.251	1
			25	0	22.80	21.82	20.68	19.81	0.380	0.303	0.233	0.191	1
	132647	1777.5	1	0	23.71	22.75	21.79	20.57	0.469	0.376	0.301	0.228	1
				12	23.70	22.75	21.95	20.81	0.468	0.376	0.313	0.240	1
				24	23.72	23.07	21.92	20.75	0.470	0.405	0.310	0.237	1
			25	0	22.69	21.74	20.68	19.76	0.371	0.298	0.233	0.189	1
10	132022	1715	1	0	23.51	22.89	22.13	20.67	0.448	0.388	0.326	0.233	1
				24	23.53	22.57	21.65	20.73	0.450	0.361	0.292	0.236	1
				49	23.44	22.63	21.67	20.56	0.441	0.366	0.293	0.227	1
			50	0	22.66	21.64	20.68	19.72	0.368	0.291	0.233	0.187	1
	132322	1745	1	0	23.76	22.99	22.15	20.60	0.474	0.397	0.327	0.229	1
				24	23.91	22.96	21.91	21.05	0.491	0.394	0.310	0.254	1
				49	23.67	23.03	21.76	20.77	0.465	0.401	0.299	0.238	1
			50	0	22.84	21.85	20.84	19.68	0.384	0.305	0.242	0.185	1
	132622	1775	1	0	23.83	22.90	22.00	20.69	0.482	0.389	0.316	0.234	1
				24	23.63	23.09	22.02	20.47	0.460	0.406	0.318	0.222	1
				49	23.66	22.77	21.87	20.60	0.463	0.378	0.307	0.229	1
			50	0	22.83	21.84	20.90	19.70	0.383	0.305	0.245	0.186	1

Note:

1. RF Output Power (W) EIRP = Conducted Output Power (dBm) + Antenna Gain (dBi)

2. Power (W) = $(10^{(\text{Power(dBm)}/10)}) * 10^{-3}$

Mode					Conducted Power				EIRP Power				Limit
BW (MHz)	Channel	Frequency (MHz)	RB No.	RB offset	QPSK (dBm)	16-QAM (dBm)	64-QAM (dBm)	256-QAM (dBm)	QPSK EIRP(W)	16-QAM EIRP(W)	64-QAM EIRP(W)	256-QAM EIRP(W)	Limit EIRP(W)
15	132047	1717.5	1	0	23.33	22.78	21.60	20.29	0.430	0.378	0.288	0.213	1
				37	23.65	22.58	21.48	20.71	0.462	0.361	0.281	0.235	1
				74	23.53	22.21	21.79	20.40	0.450	0.332	0.301	0.219	1
			75	0	22.47	21.42	20.42	19.55	0.352	0.277	0.220	0.180	1
	132322	1745	1	0	23.52	22.78	21.90	20.61	0.449	0.378	0.309	0.230	1
				37	24.00	23.05	21.52	21.04	0.501	0.403	0.283	0.254	1
				74	23.67	22.89	22.29	20.58	0.465	0.388	0.338	0.228	1
			75	0	22.69	21.67	20.77	19.73	0.371	0.293	0.238	0.187	1
	132597	1772.5	1	0	23.75	22.70	21.68	20.78	0.473	0.372	0.294	0.239	1
				37	23.54	22.92	22.13	20.50	0.451	0.391	0.326	0.224	1
				74	23.69	23.00	21.61	20.56	0.467	0.398	0.289	0.227	1
			75	0	22.60	21.55	20.64	19.61	0.363	0.285	0.231	0.182	1
20	132072	1720	1	0	23.32	22.71	21.40	20.22	0.429	0.372	0.275	0.210	1
				49	23.60	22.56	21.68	20.75	0.457	0.360	0.294	0.237	1
				99	23.97	22.63	21.66	20.90	0.498	0.366	0.292	0.245	1
			100	0	22.40	21.41	20.46	19.48	0.347	0.276	0.222	0.177	1
	132322	1745	1	0	23.54	22.93	21.76	20.41	0.451	0.392	0.299	0.219	1
				49	23.92	23.32	21.93	20.88	0.492	0.429	0.311	0.244	1
				99	23.86	22.88	21.99	21.00	0.485	0.387	0.316	0.251	1
			100	0	22.68	21.65	20.76	19.79	0.370	0.292	0.238	0.190	1
	132572	1770	1	0	24.02	23.62	22.54	21.16	0.504	0.459	0.358	0.261	1
				49	23.68	22.90	21.88	20.51	0.466	0.389	0.308	0.224	1
				99	23.62	22.84	22.04	20.44	0.459	0.384	0.319	0.221	1
			100	0	22.71	21.80	20.67	19.70	0.372	0.302	0.233	0.186	1

Note:

1. RF Output Power (W) EIRP = Conducted Output Power (dBm) + Antenna Gain (dBi)

2. Power (W) = $(10^{(\text{Power(dBm)/10})}) * 10^{-3}$

4. Occupied Bandwidth

4.1. Test Setup

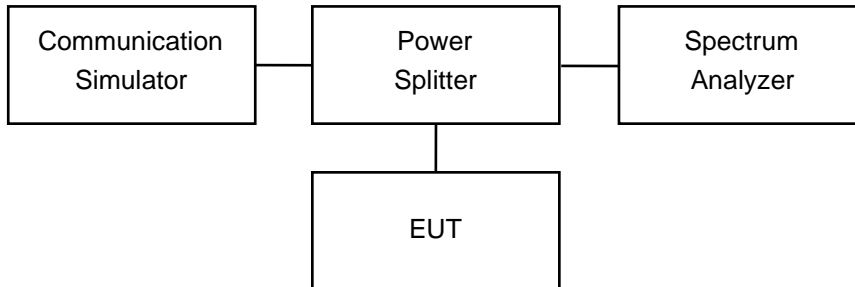

4.2. Test Procedure

The EUT makes a call to the communication simulator. The 26dB bandwidth and 99% occupied bandwidth measurements were done at low, middle and high operational frequency range. The communication simulator station system controlled a EUT to export maximum output power under transmission mode and specific channel frequency. The path loss was compensated to the results for each measurement.

4.3. Test Methodology and Reference Procedures

KDB 971168 D01 Power Meas License Digital Systems v03r01

ANSI C63.26-2015

4.4. Test Result of Occupied Bandwidth

Mode 1: LTE Band 2

Bandwidth (MHz)	Modulation	Channel	Frequency (MHz)	Measure Level (MHz)		Limit (MHz)
				26dB BW	99% BW	
1.4	QPSK	18607	1850.7	1.272	1.079	N/A
		18900	1880	1.294	1.080	N/A
		19193	1909.3	1.254	1.079	N/A
	16-QAM	18607	1850.7	1.325	1.083	N/A
		18900	1880	1.286	1.080	N/A
		19193	1909.3	1.297	1.082	N/A
	64-QAM	18607	1850.7	1.290	1.078	N/A
		18900	1880	1.296	1.080	N/A
		19193	1909.3	1.288	1.082	N/A
	256-QAM	18607	1850.7	1.284	1.081	N/A
		18900	1880	1.316	1.081	N/A
		19193	1909.3	1.308	1.079	N/A
3	QPSK	18615	1851.5	2.967	2.691	N/A
		18900	1880	2.972	2.684	N/A
		19185	1908.5	2.949	2.684	N/A
	16-QAM	18615	1851.5	2.994	2.688	N/A
		18900	1880	2.996	2.687	N/A
		19185	1908.5	2.960	2.686	N/A
	64-QAM	18615	1851.5	2.955	2.683	N/A
		18900	1880	2.961	2.690	N/A
		19185	1908.5	2.978	2.688	N/A
	256-QAM	18615	1851.5	2.946	2.687	N/A
		18900	1880	2.987	2.688	N/A
		19185	1908.5	2.986	2.687	N/A
5	QPSK	18625	1852.5	4.995	4.480	N/A
		18900	1880	4.984	4.480	N/A
		19175	1907.5	4.989	4.479	N/A
	16-QAM	18625	1852.5	4.928	4.479	N/A
		18900	1880	4.960	4.480	N/A
		19175	1907.5	4.936	4.476	N/A
	64-QAM	18625	1852.5	4.968	4.476	N/A
		18900	1880	4.962	4.475	N/A
		19175	1907.5	4.957	4.476	N/A
	256-QAM	18625	1852.5	4.955	4.470	N/A
		18900	1880	4.986	4.492	N/A
		19175	1907.5	4.990	4.474	N/A

Bandwidth (MHz)	Modulation	Channel	Frequency (MHz)	Measure Level (MHz)		Limit (MHz)
				26dB BW	99% BW	
10	QPSK	18650	1855	9.805	8.941	N/A
		18900	1880	9.779	8.950	N/A
		19150	1905	9.864	8.954	N/A
	16-QAM	18650	1855	9.832	8.947	N/A
		18900	1880	9.864	8.945	N/A
		19150	1905	9.847	8.948	N/A
	64-QAM	18650	1855	9.676	8.945	N/A
		18900	1880	9.816	8.943	N/A
		19150	1905	9.866	8.940	N/A
	256-QAM	18650	1855	9.804	8.942	N/A
		18900	1880	9.791	8.943	N/A
		19150	1905	9.816	8.938	N/A
15	QPSK	18675	1857.5	14.600	13.440	N/A
		18900	1880	14.510	13.404	N/A
		19125	1902.5	14.780	13.421	N/A
	16-QAM	18675	1857.5	14.640	13.418	N/A
		18900	1880	14.710	13.405	N/A
		19125	1902.5	14.730	13.406	N/A
	64-QAM	18675	1857.5	14.610	13.414	N/A
		18900	1880	14.630	13.445	N/A
		19125	1902.5	14.580	13.419	N/A
	256-QAM	18675	1857.5	14.520	13.433	N/A
		18900	1880	14.560	13.433	N/A
		19125	1902.5	14.580	13.447	N/A
20	QPSK	18700	1860	19.510	17.878	N/A
		18900	1880	19.220	17.869	N/A
		19100	1900	19.400	17.902	N/A
	16-QAM	18700	1860	19.330	17.888	N/A
		18900	1880	19.410	17.894	N/A
		19100	1900	19.330	17.893	N/A
	64-QAM	18700	1860	19.300	17.881	N/A
		18900	1880	19.420	17.870	N/A
		19100	1900	19.330	17.918	N/A
	256-QAM	18700	1860	19.310	17.876	N/A
		18900	1880	19.330	17.874	N/A
		19100	1900	19.480	17.917	N/A

QPSK_CH18607_1.4M_6RB0

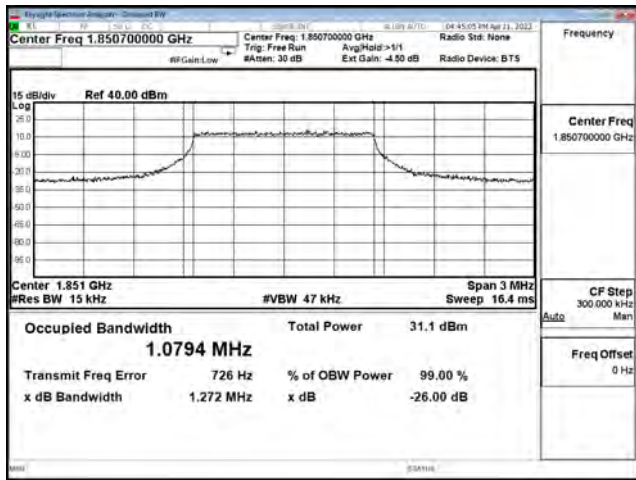

QPSK_CH18900_1.4M_6RB0

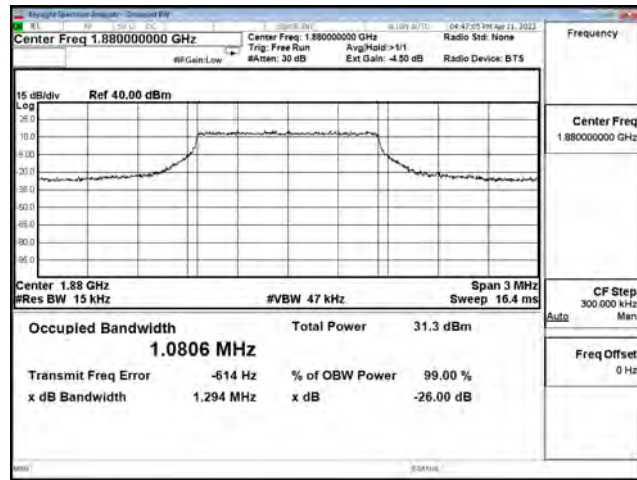

QPSK_CH19193_1.4M_6RB0

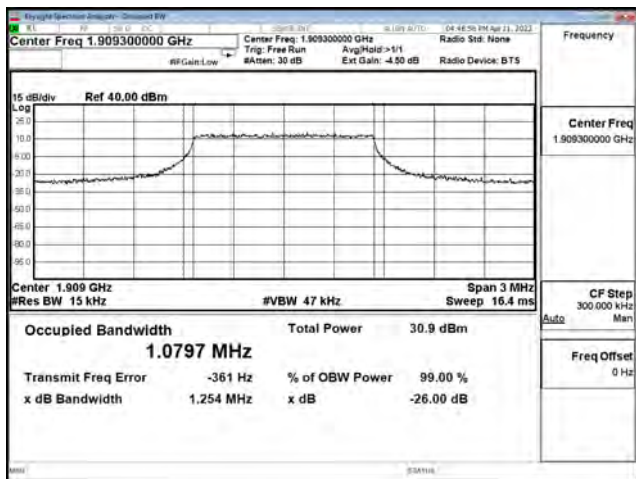

16QAM_CH18607_1.4M_6RB0

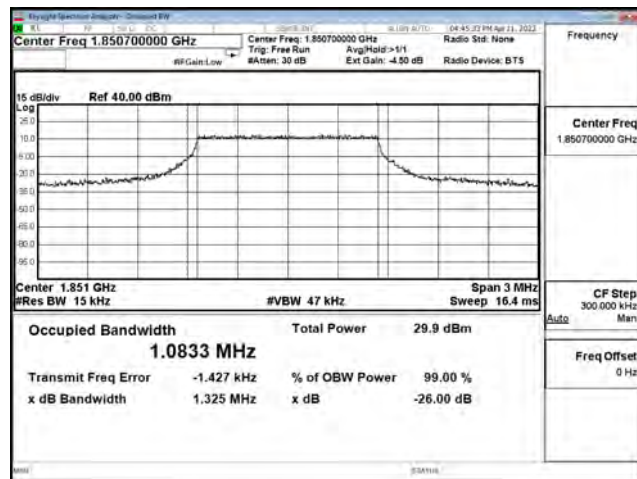

16QAM_CH18900_1.4M_6RB0

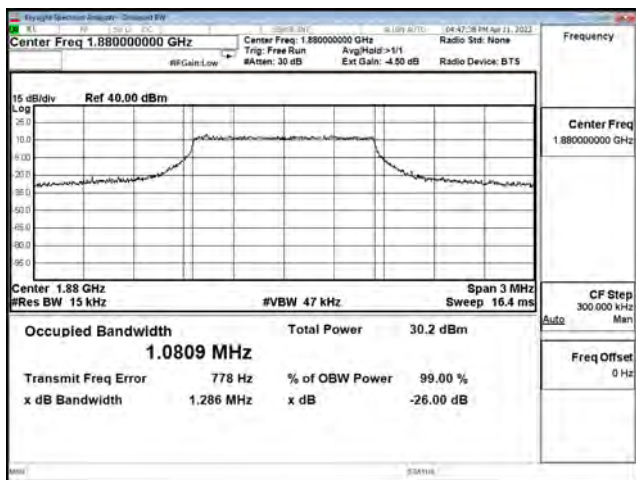

16QAM_CH19193_1.4M_6RB0

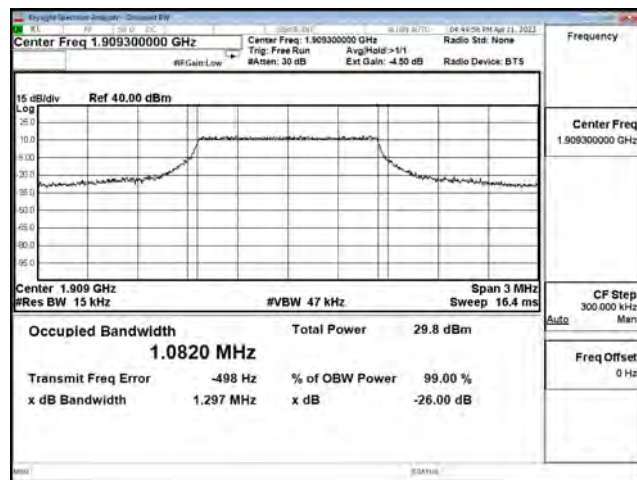

64-QAM_CH18607_1.4M_6RB0

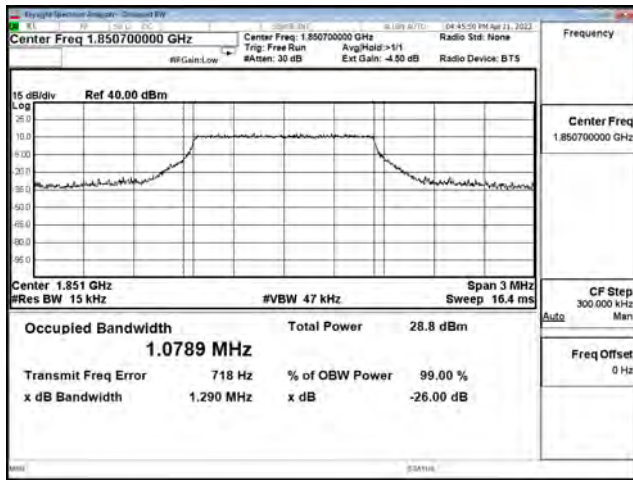

64-QAM_CH18900_1.4M_6RB0

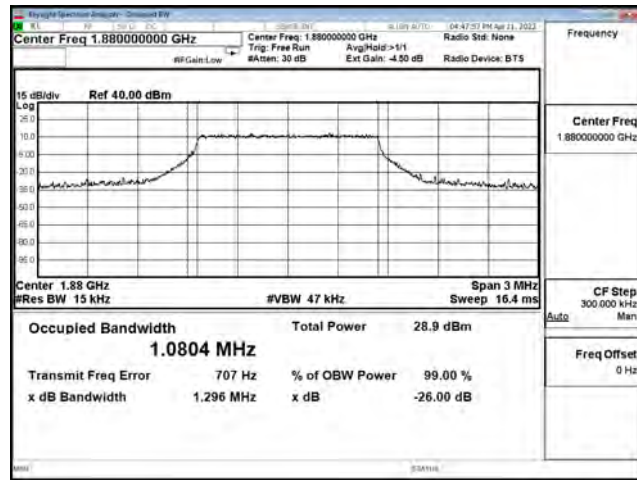

64-QAM_CH19193_1.4M_6RB0

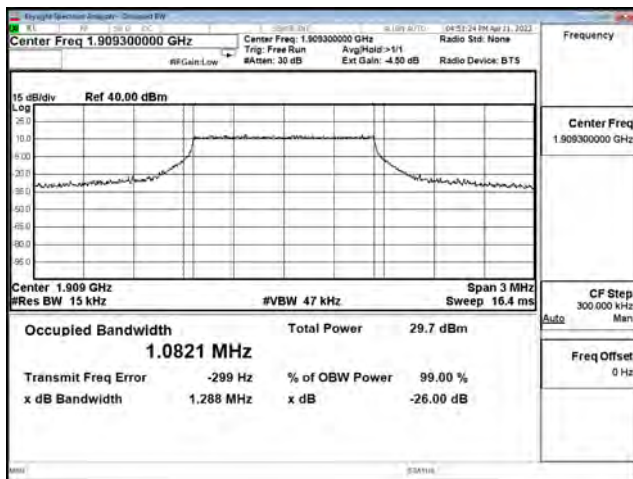

256-QAM_CH18607_1.4M_6RB0

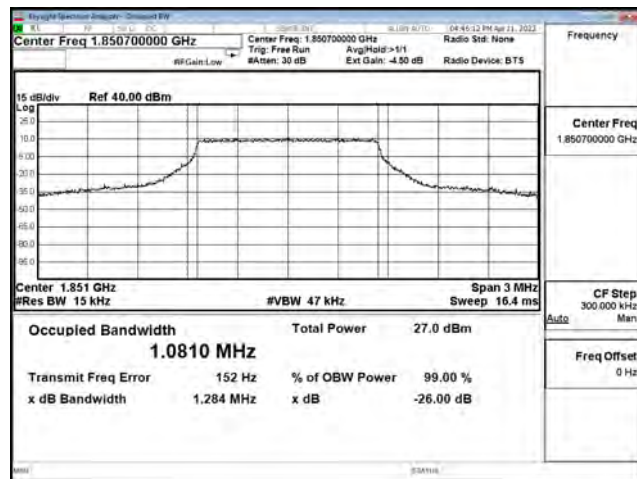

256-QAM_CH18900_1.4M_6RB0

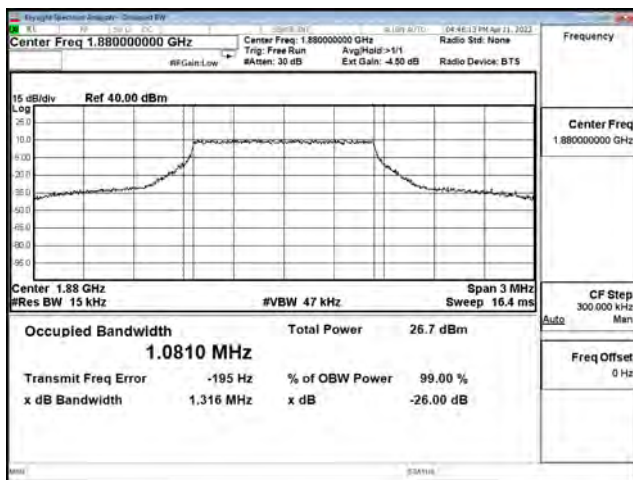

256-QAM_CH19193_1.4M_6RB0

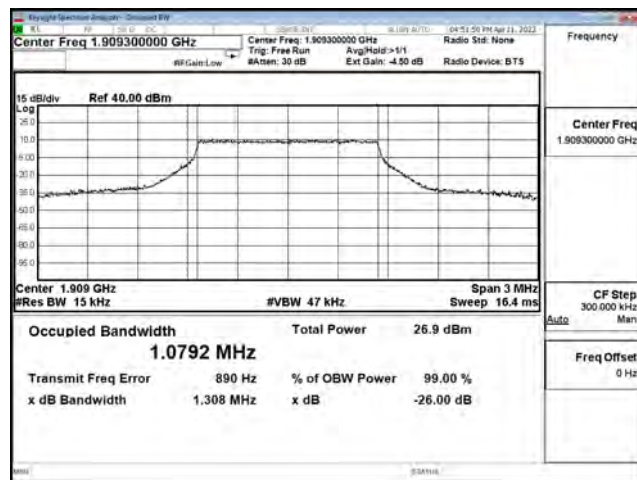

QPSK_CH18615_3M_15RB0

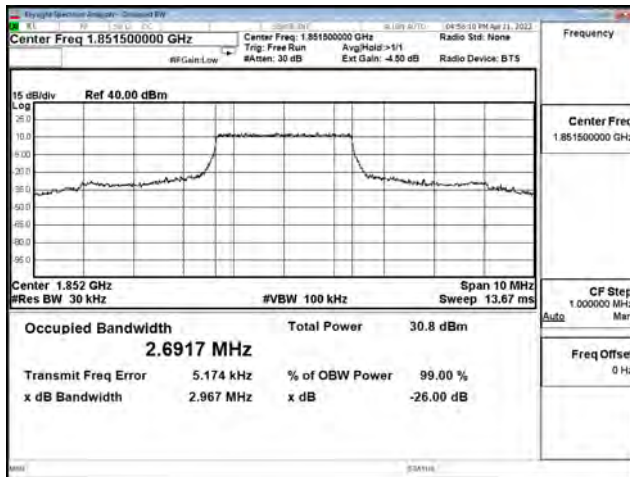

QPSK_CH18900_3M_15RB0

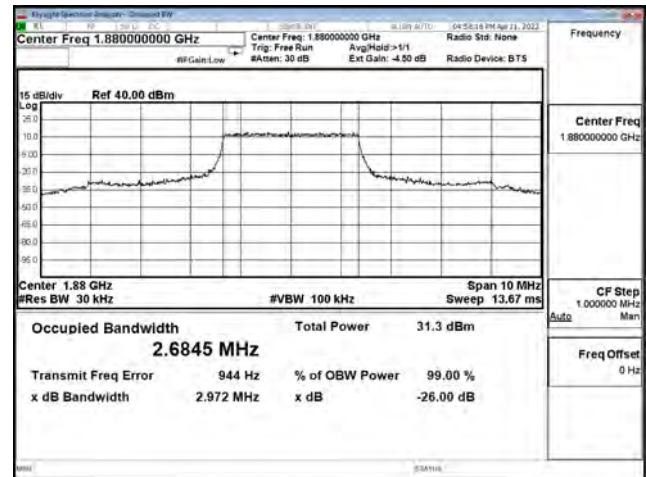

QPSK_CH19185_3M_15RB0

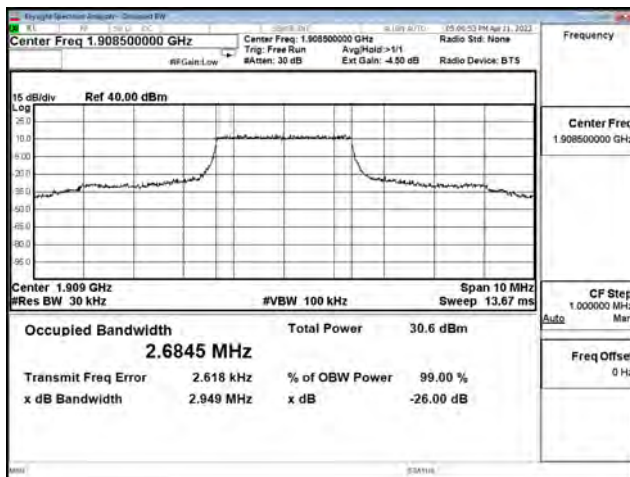

16QAM_CH18615_3M_15RB0

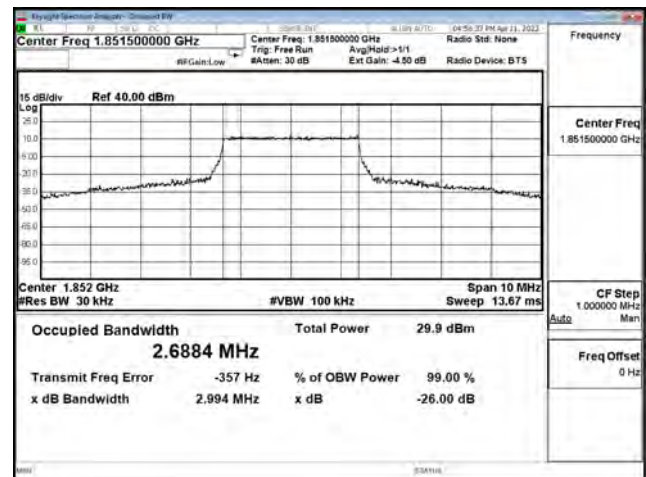

16QAM_CH18900_3M_15RB0

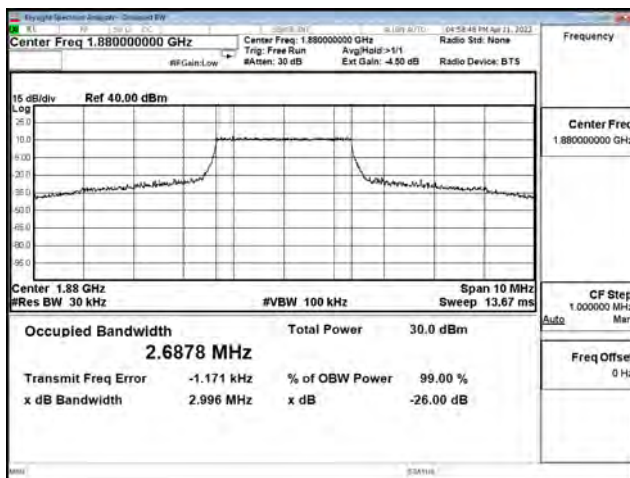

16QAM_CH19185_3M_15RB0

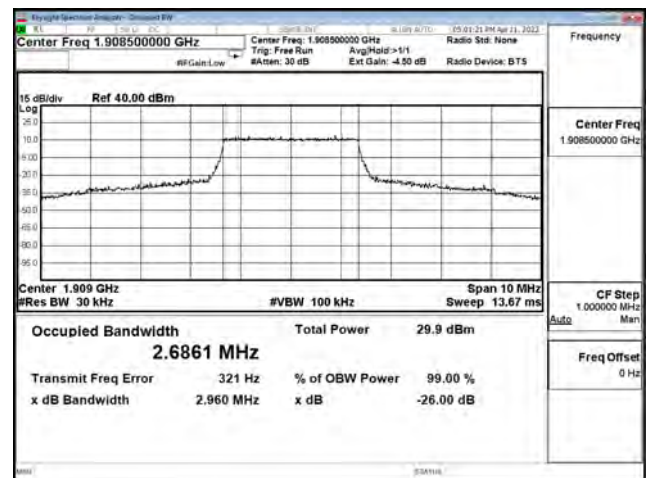

64-QAM_CH18615_3M_15RB0

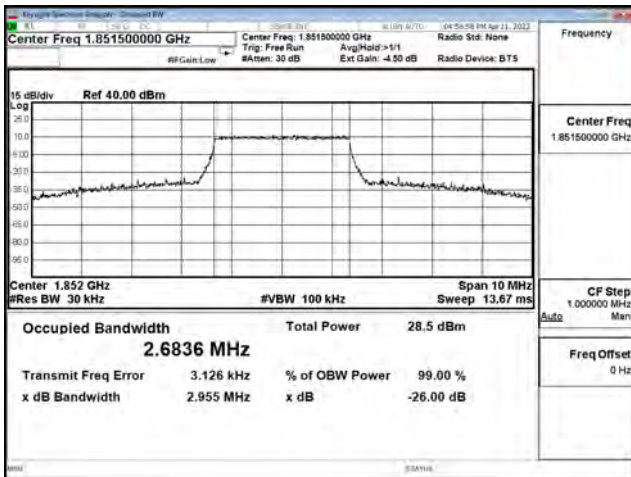

64-QAM_CH18900_3M_15RB0

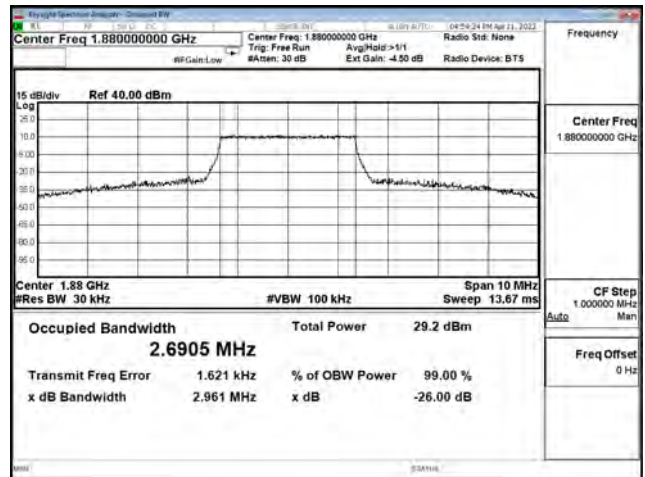

64-QAM_CH19185_3M_15RB0

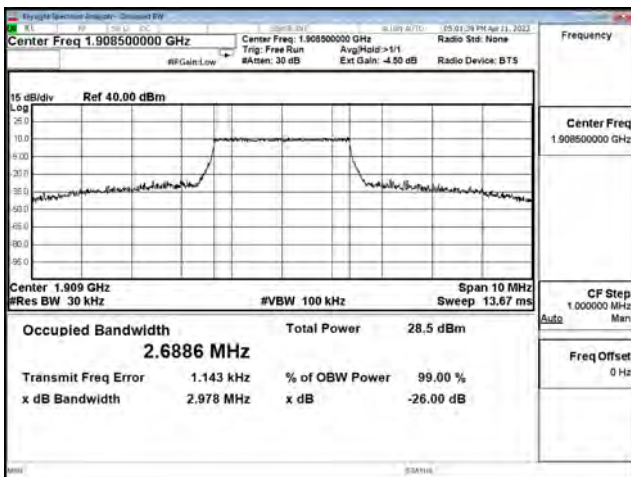

256-QAM_CH18615_3M_15RB0

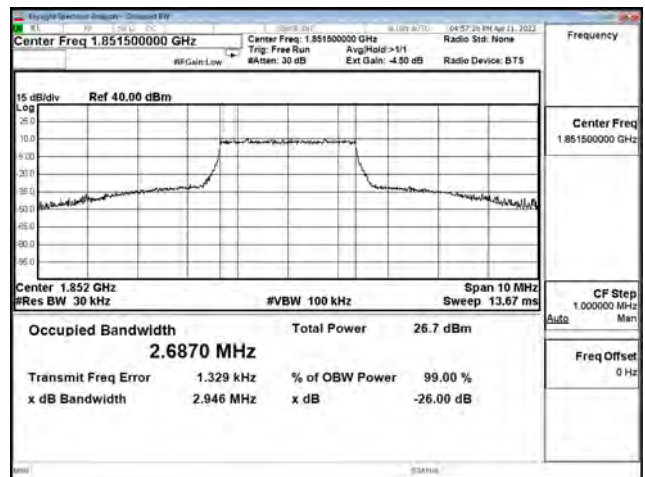

256-QAM_CH18900_3M_15RB0

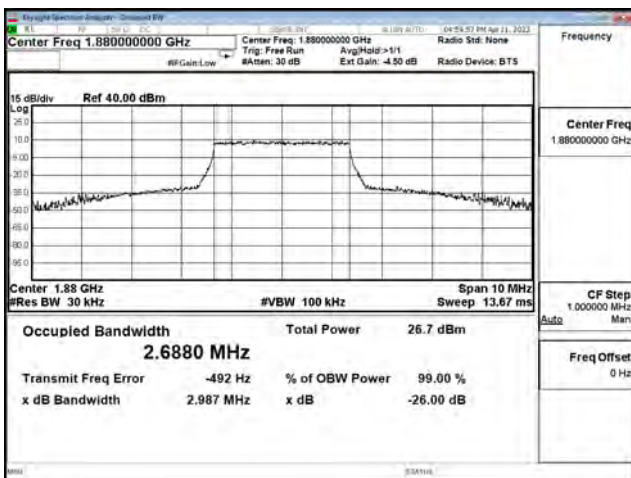

256-QAM_CH19185_3M_15RB0

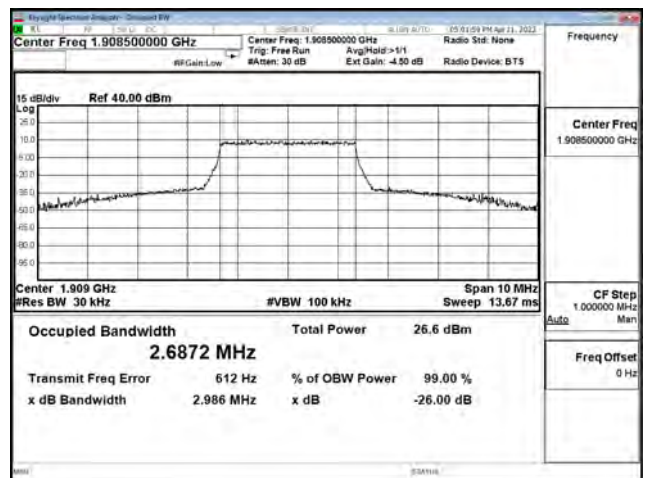

QPSK_CH18625_5M_25RB0

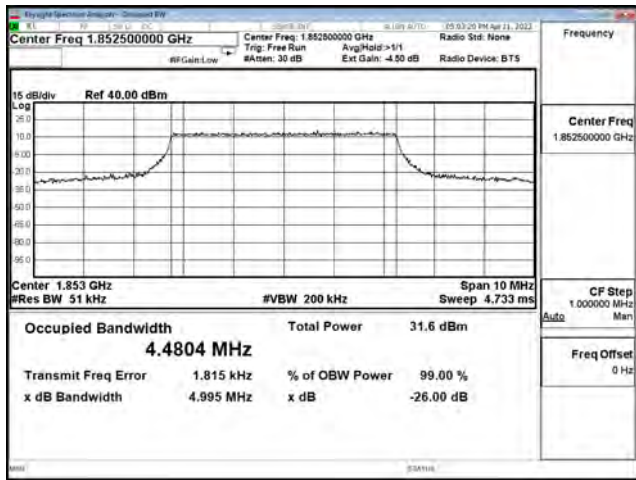

QPSK_CH18900_5M_25RB0

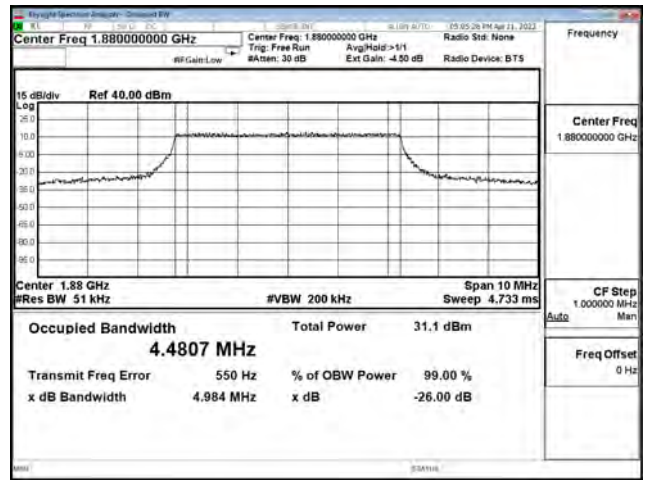

QPSK_CH19175_5M_25RB0

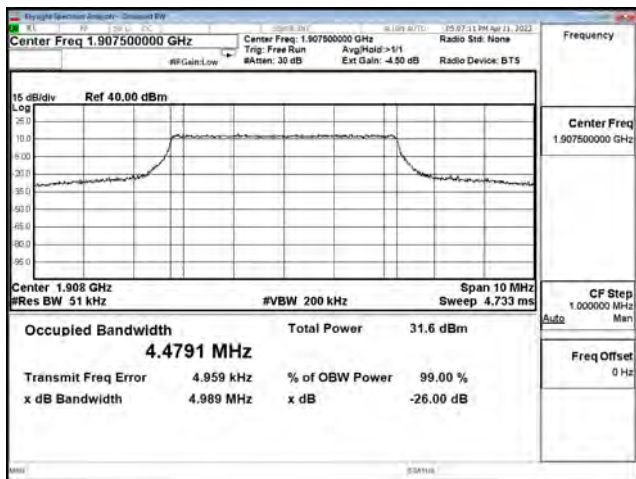

16QAM_CH18625_5M_25RB0

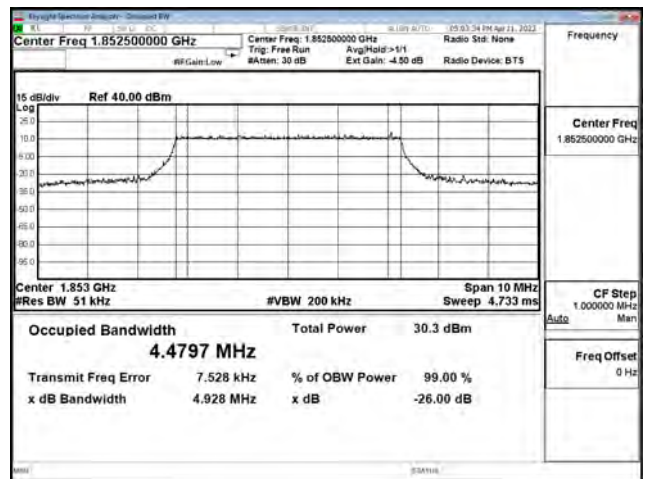

16QAM_CH18900_5M_25RB0

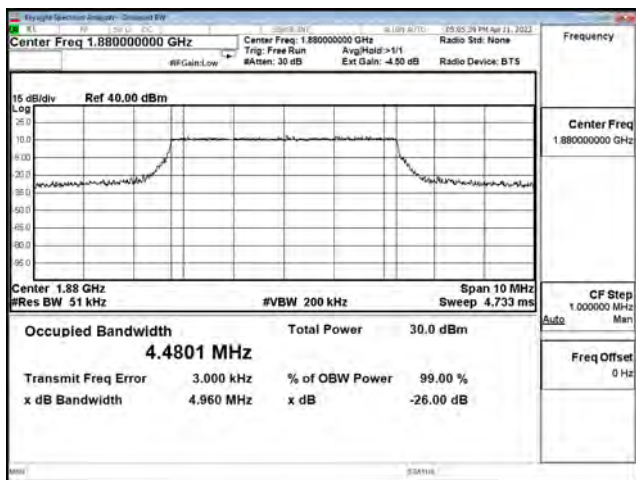

16QAM_CH19175_5M_25RB0

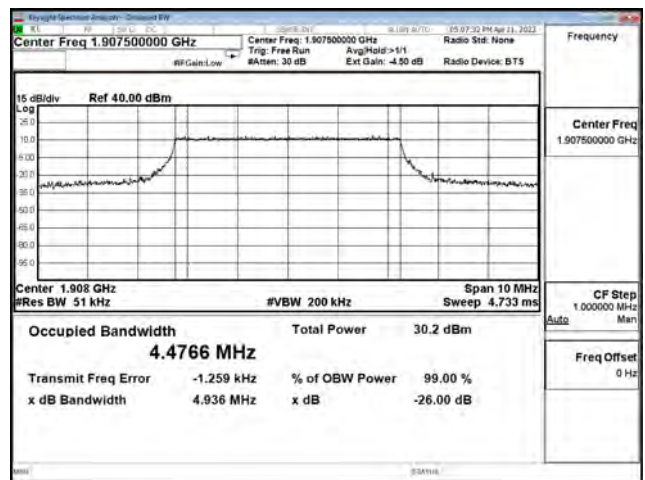

64-QAM_CH18625_5M_25RB0

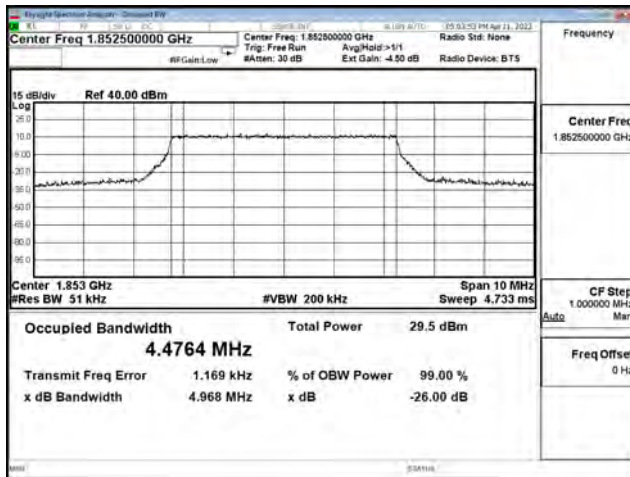

64-QAM_CH18900_5M_25RB0

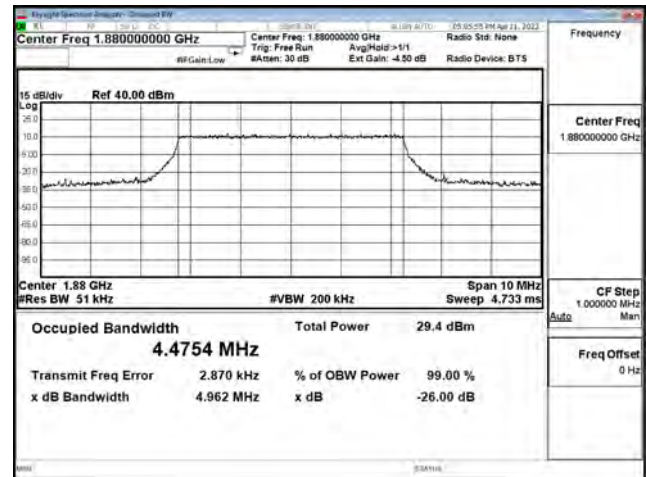

64-QAM_CH19175_5M_25RB0

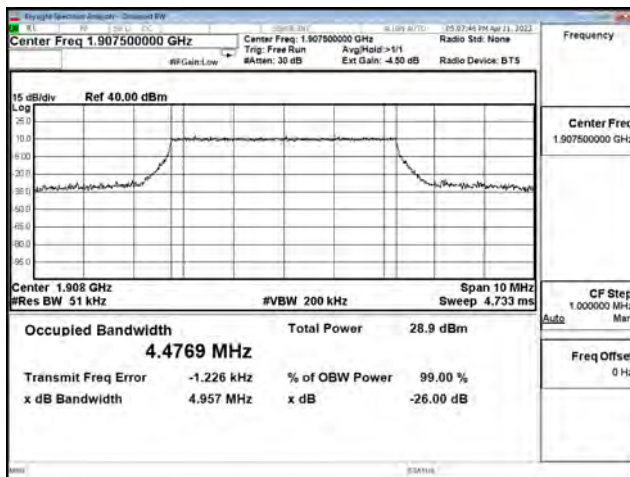

256-QAM_CH18625_5M_25RB0

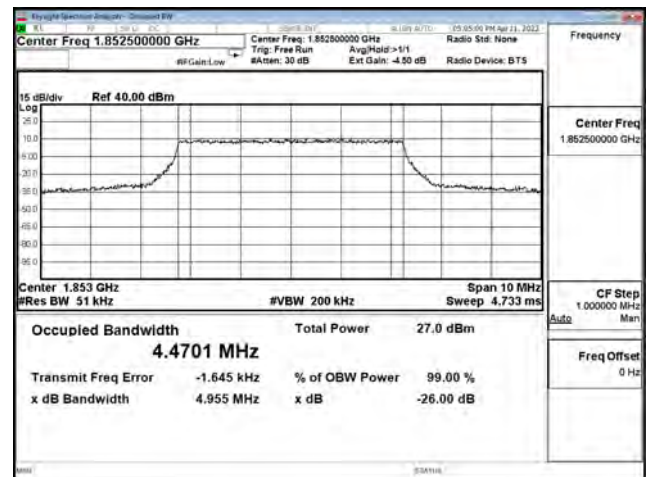

256-QAM_CH18900_5M_25RB0

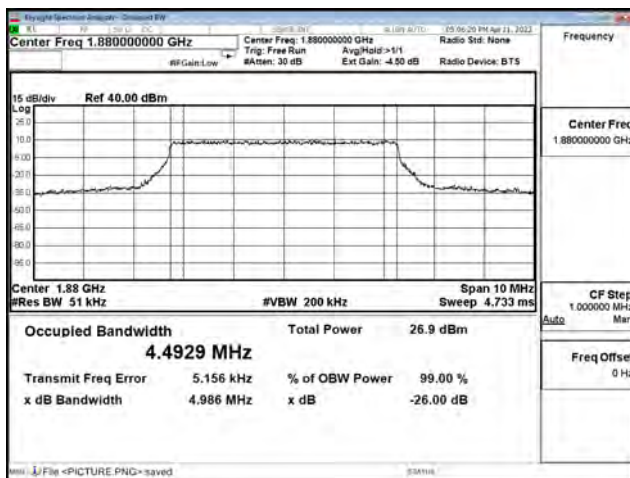

256-QAM_CH19175_5M_25RB0

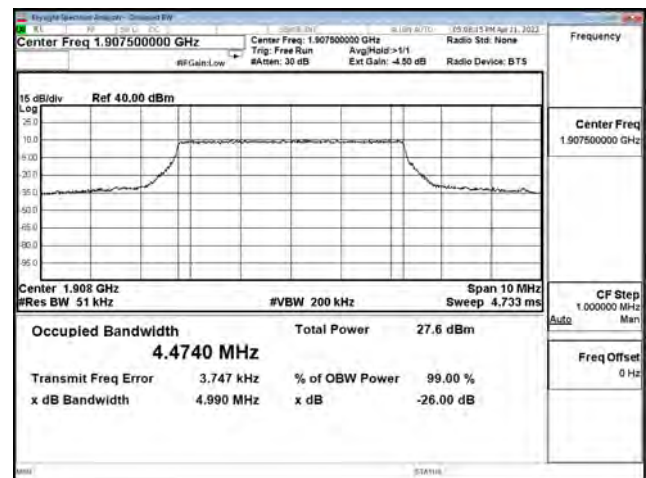

QPSK_CH18650_10M_50RB0

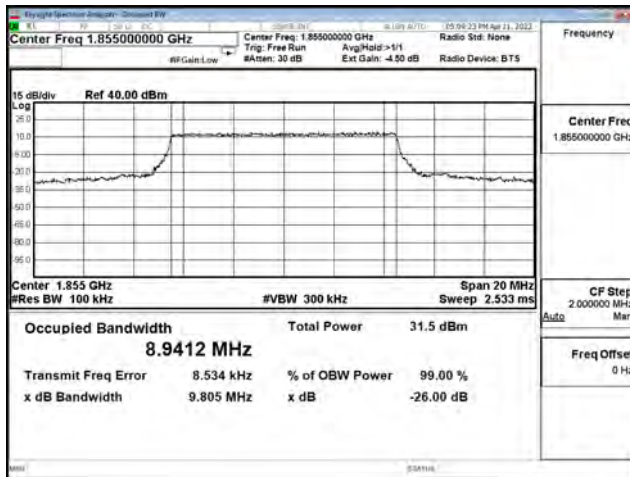

QPSK_CH18900_10M_50RB0

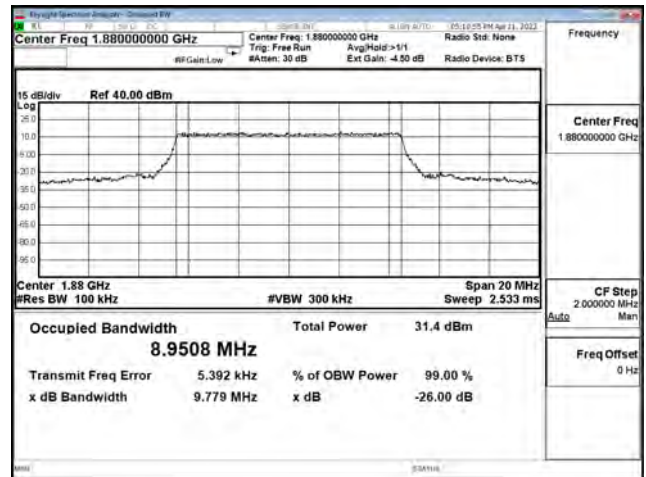

QPSK_CH19150_10M_50RB0

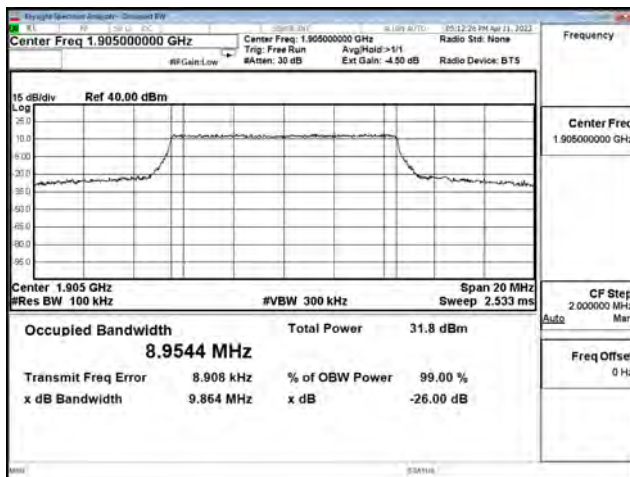

16QAM_CH18650_10M_50RB0

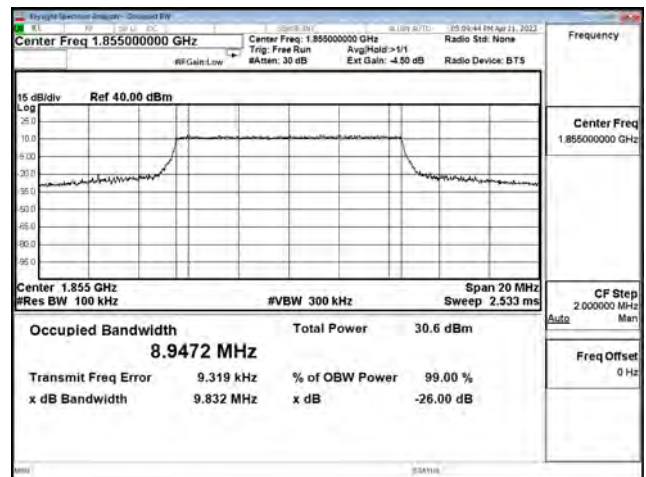

16QAM_CH18900_10M_50RB0

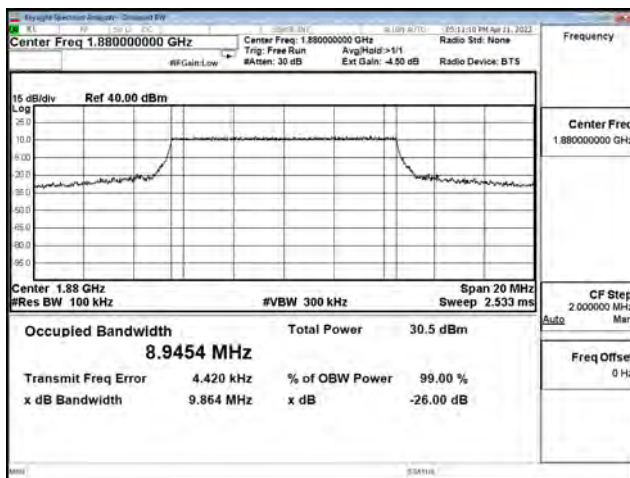

16QAM_CH19150_10M_50RB0

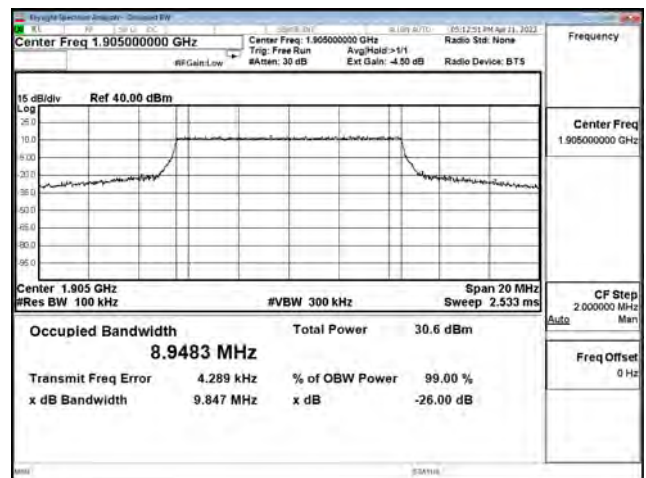

64-QAM_CH18650_10M_50RB0

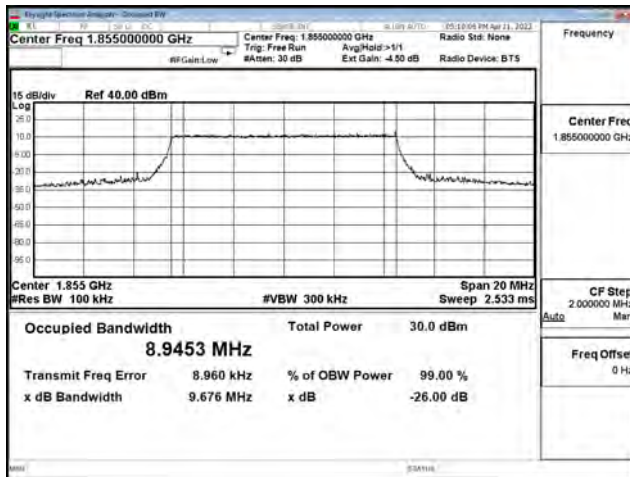

64-QAM_CH18900_10M_50RB0

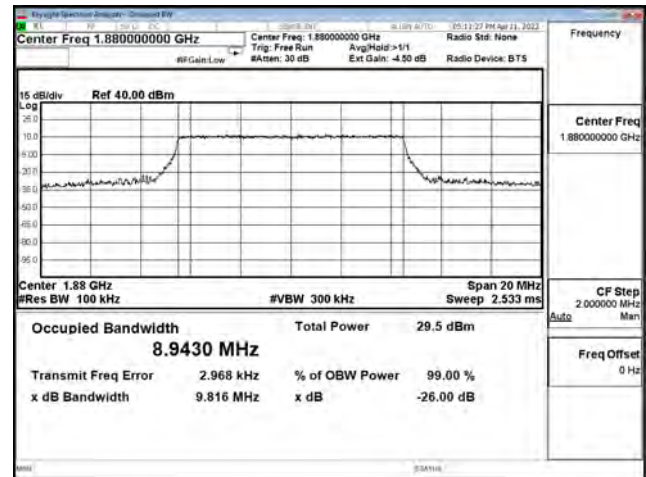

64-QAM_CH19150_10M_50RB0

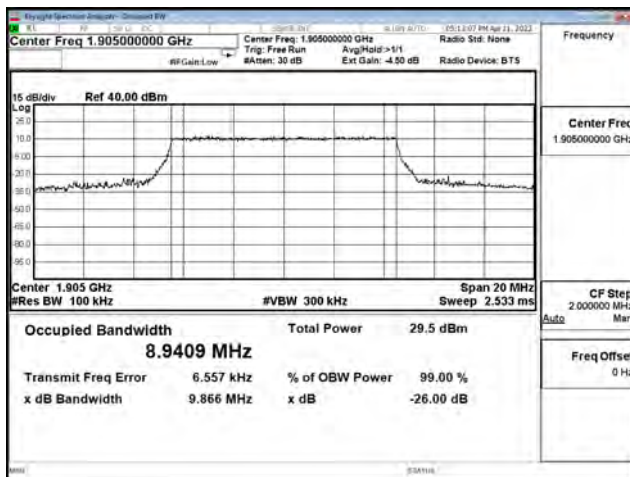

256-QAM_CH18650_10M_50RB0

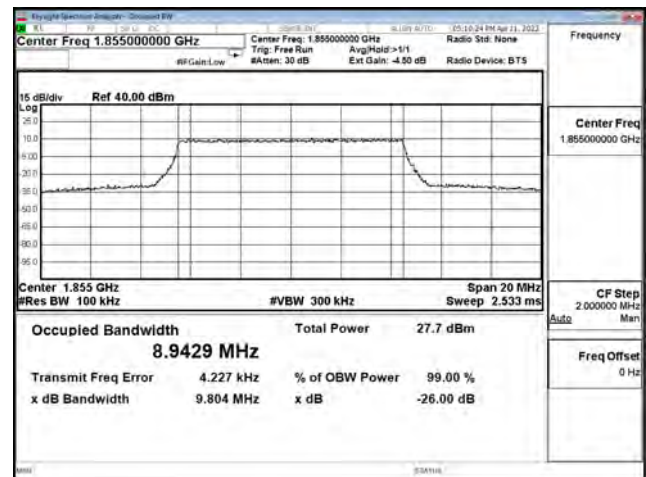

256-QAM_CH18900_10M_50RB0

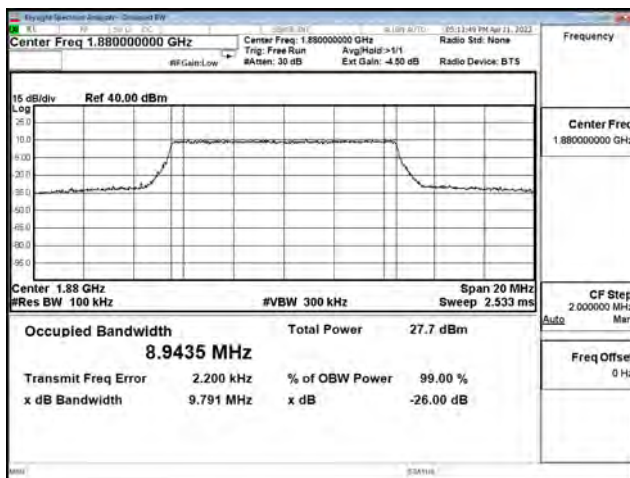

256-QAM_CH19150_10M_50RB0

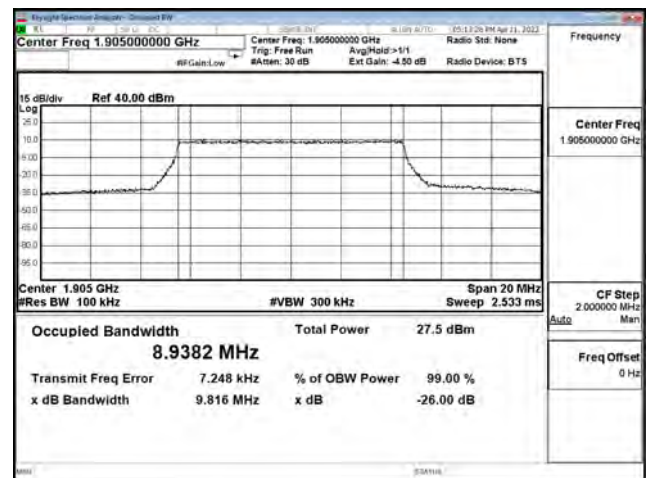

QPSK_CH18675_15M_75RB0

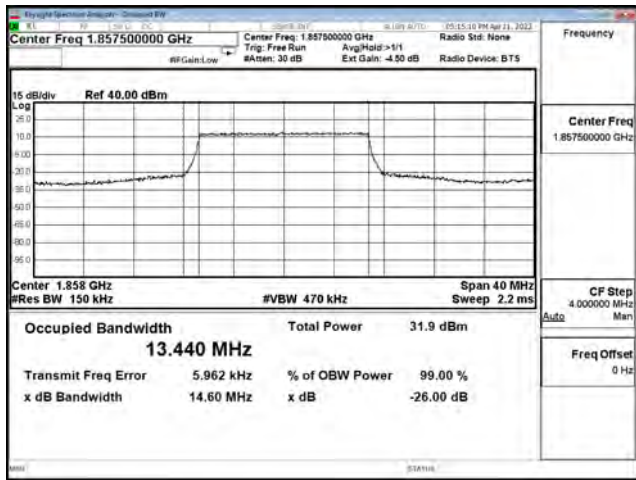

QPSK_CH18900_15M_75RB0

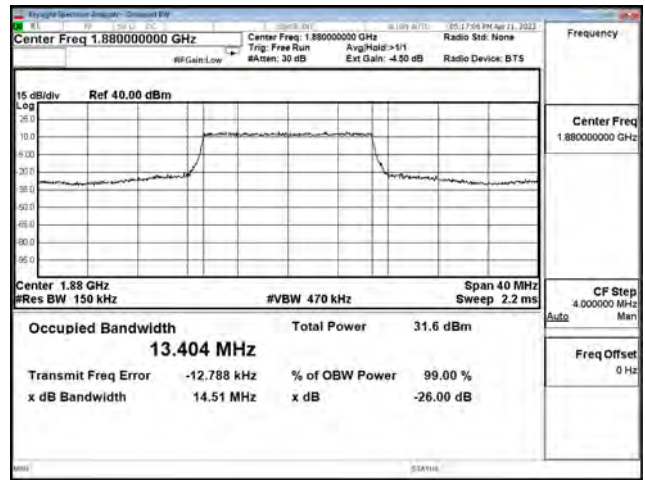

QPSK_CH19125_15M_75RB0

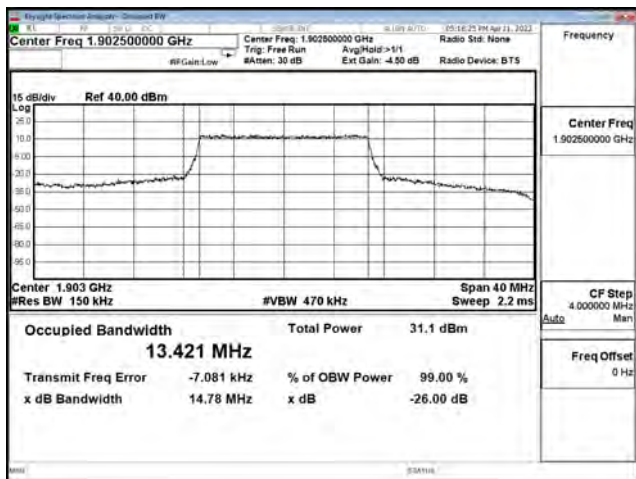

16QAM_CH18675_15M_75RB0

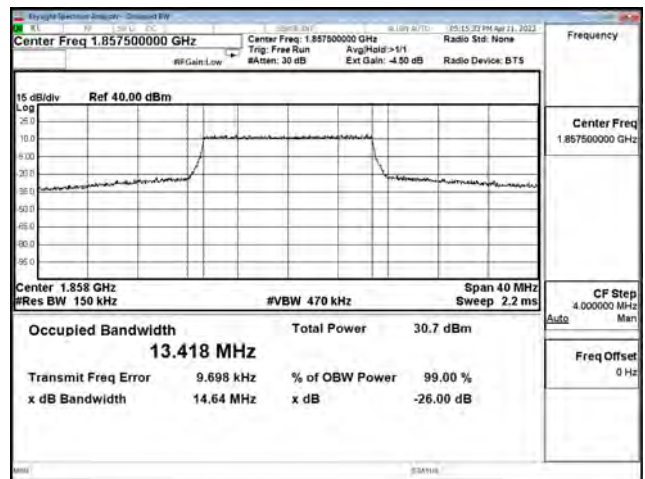

16QAM_CH18900_15M_75RB0

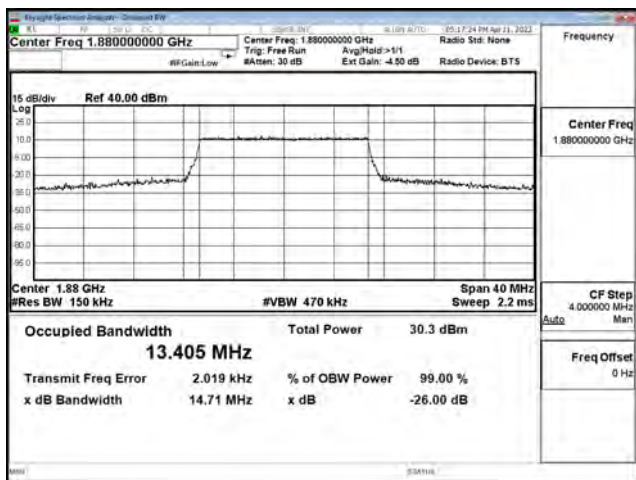

16QAM_CH19125_15M_75RB0

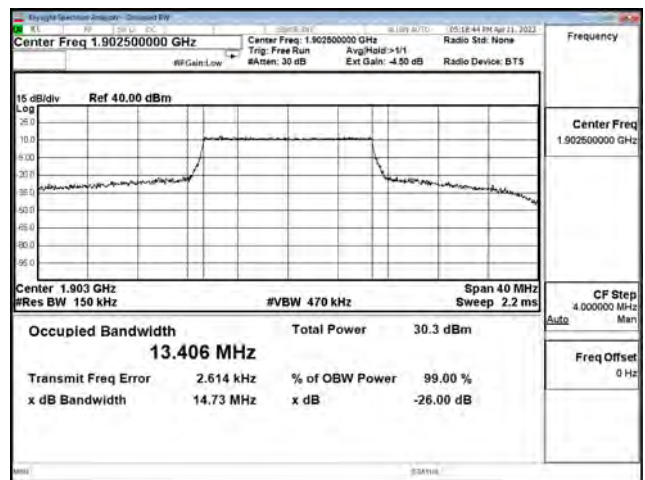

64-QAM_CH18675_15M_75RB0

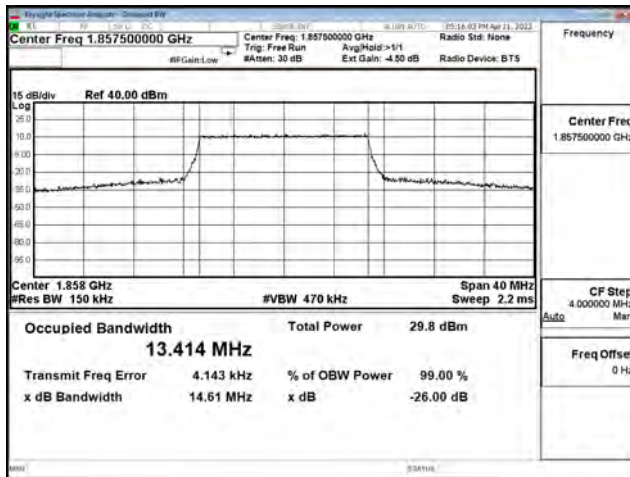

64-QAM_CH18900_15M_75RB0

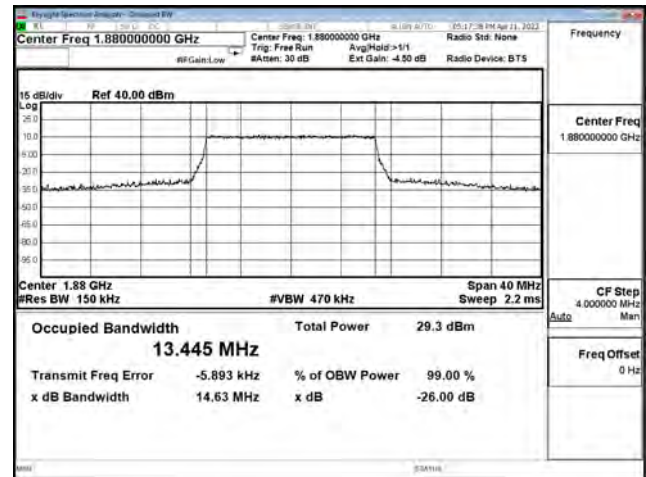

64-QAM_CH19125_15M_75RB0

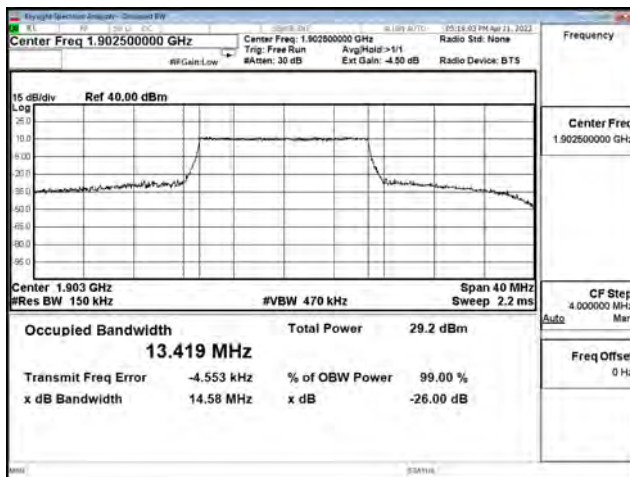

256-QAM_CH18675_15M_75RB0

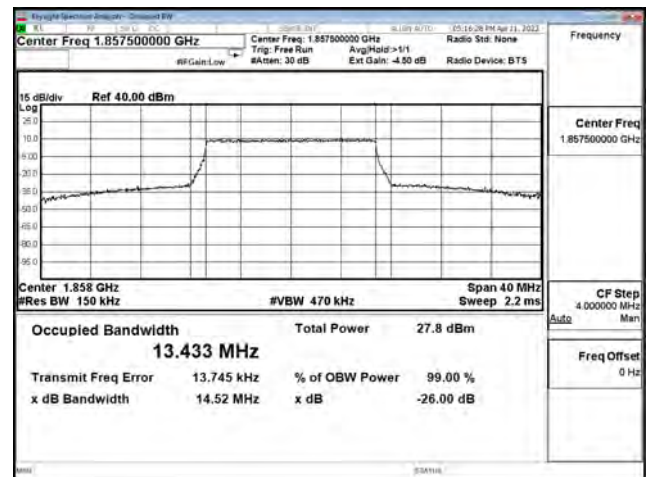

256-QAM_CH18900_15M_75RB0

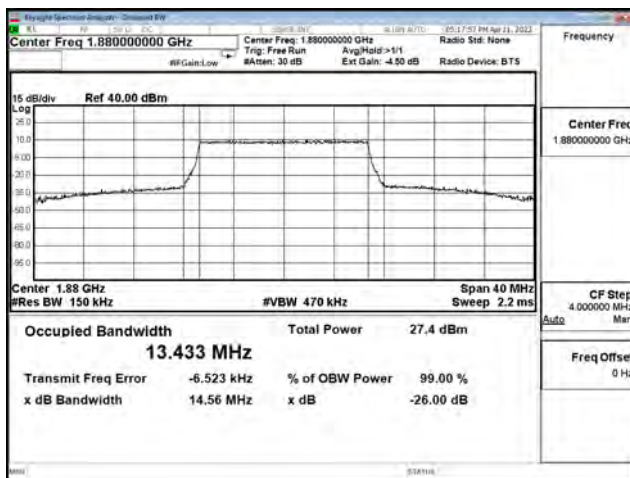

256-QAM_CH19125_15M_75RB0

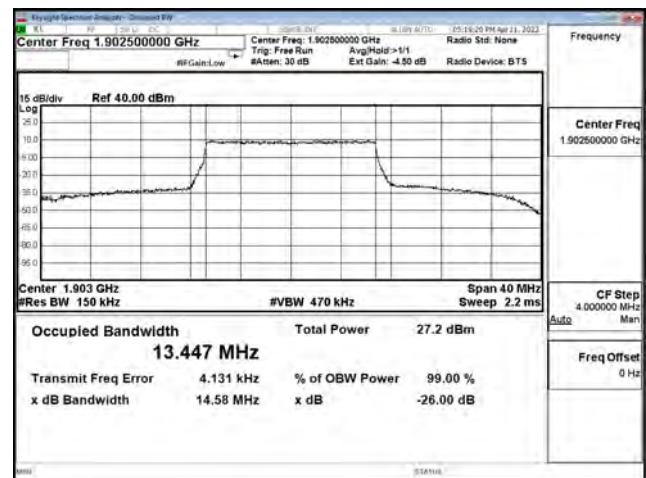

QPSK_CH18700_20M_100RB0

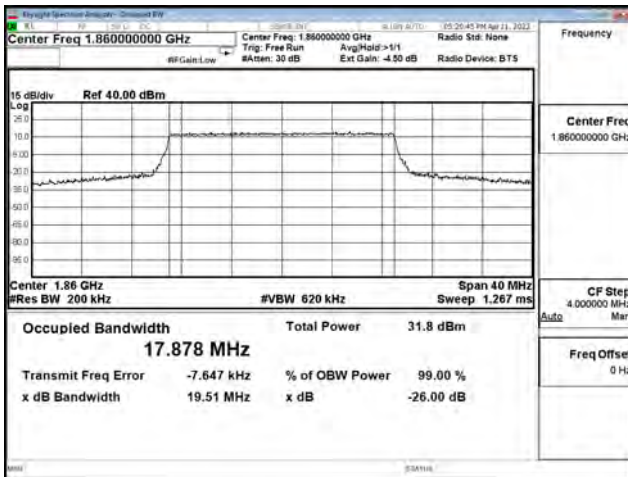

QPSK_CH18900_20M_100RB0

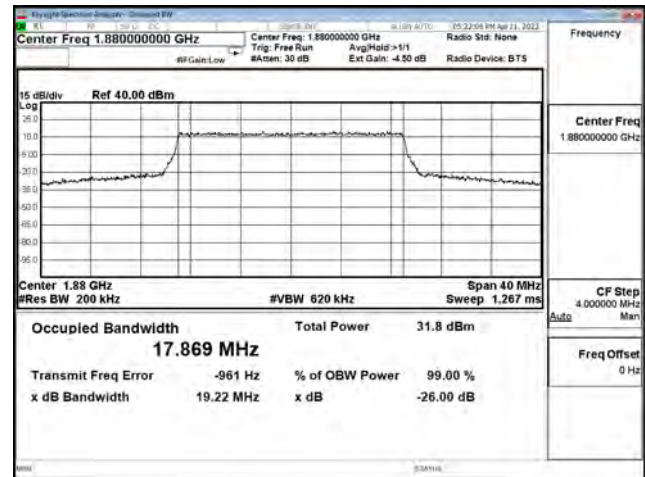

QPSK_CH19100_20M_100RB0

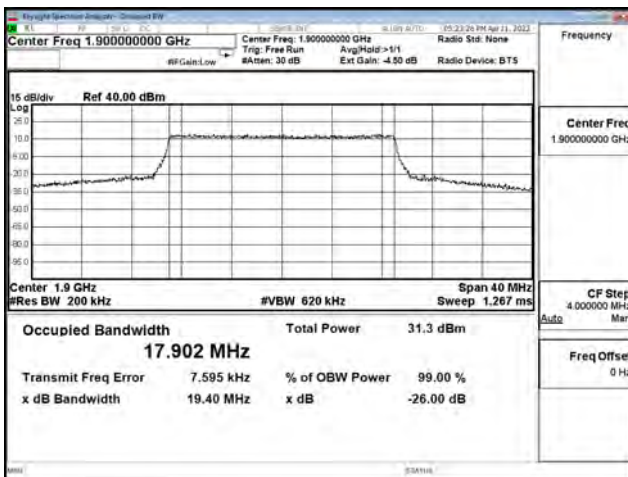

16QAM_CH18700_20M_100RB0

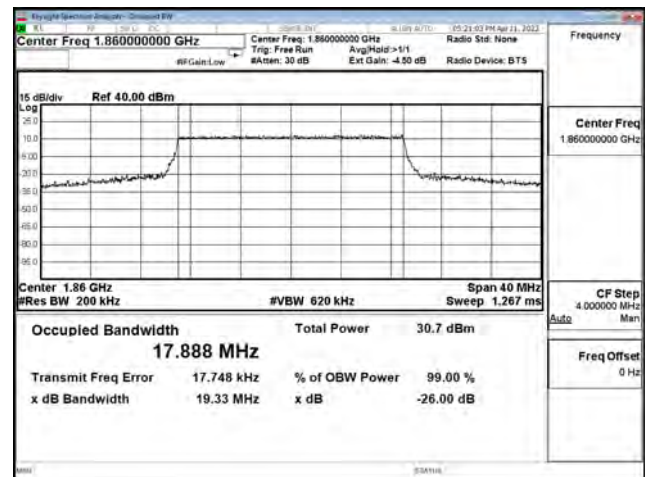

16QAM_CH18900_20M_100RB0

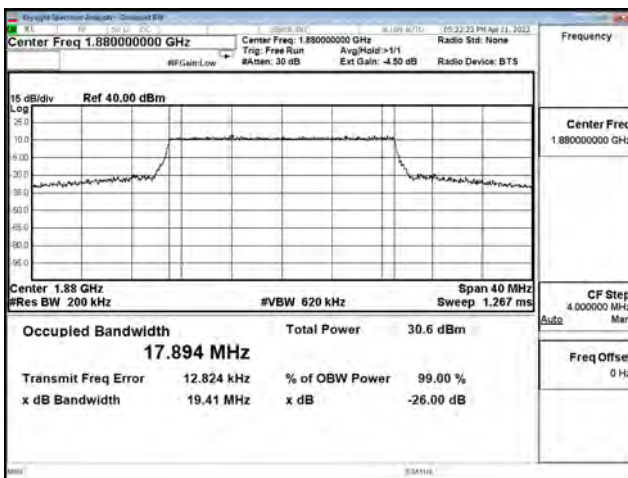

16QAM_CH19100_20M_100RB0

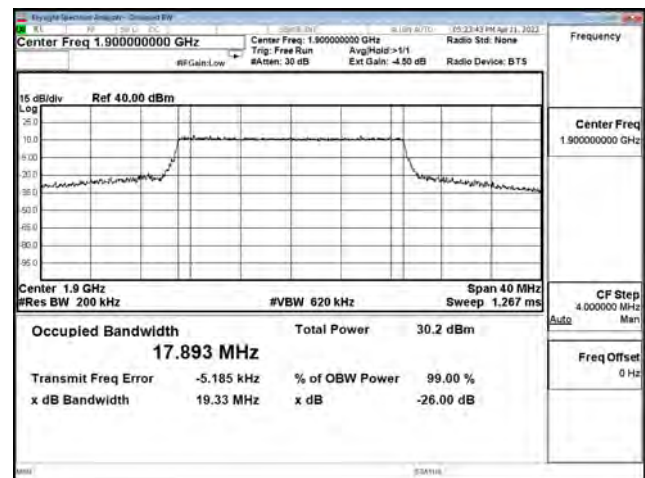

64-QAM_CH18700_20M_100RB0

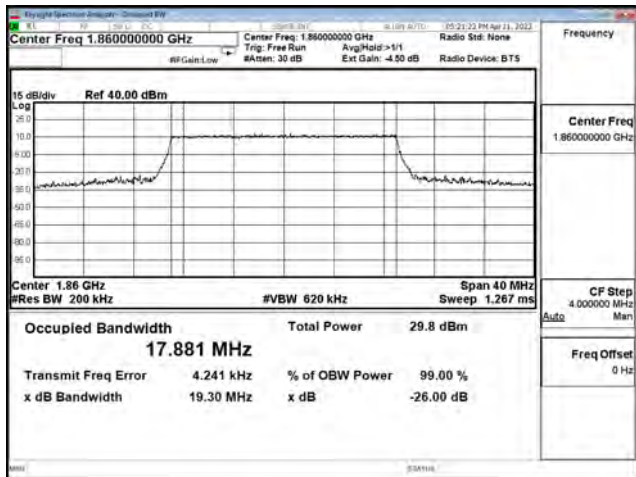

64-QAM_CH18900_20M_100RB0

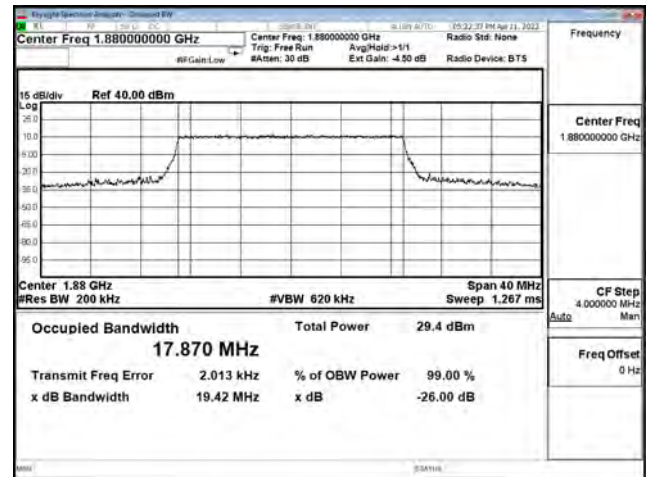

64-QAM_CH19100_20M_100RB0

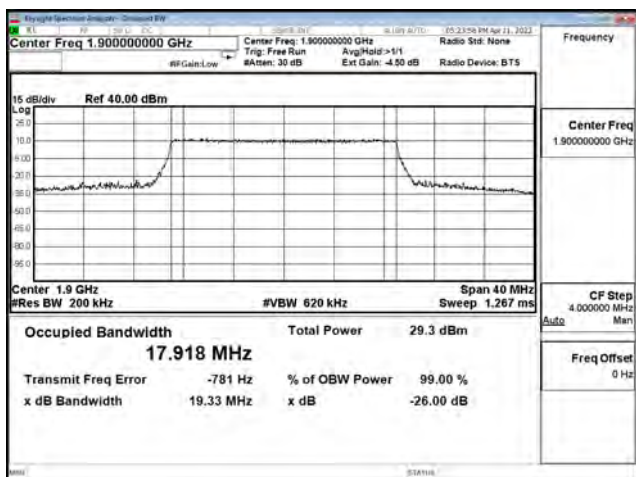

256-QAM_CH18700_20M_100RB0

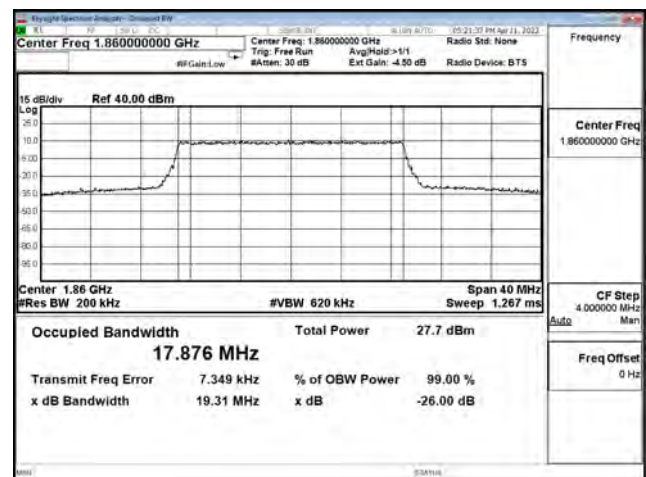

256-QAM_CH18900_20M_100RB0

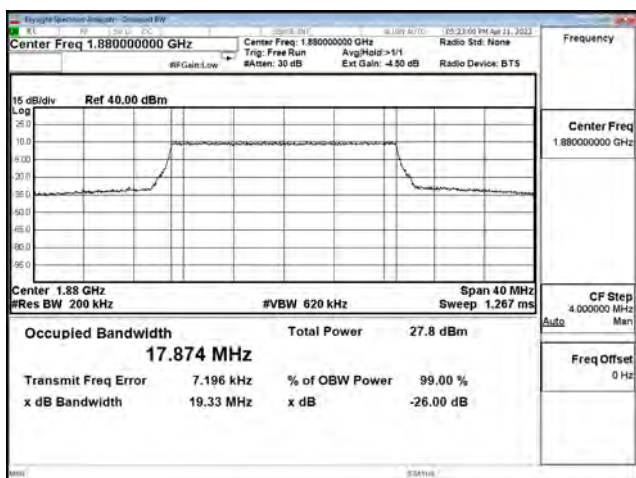

256-QAM_CH19100_20M_100RB0

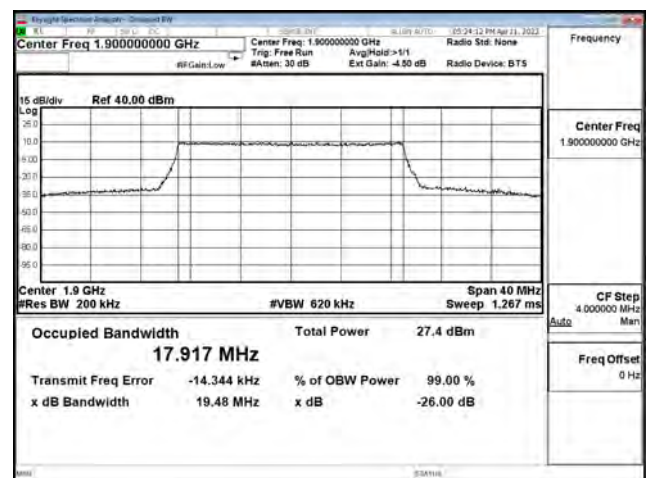

Mode 2: LTE Band 5

Bandwidth (MHz)	Modulation	Channel	Frequency (MHz)	Measure Level (MHz)		Limit (MHz)
				26dB BW	99% BW	
1.4	QPSK	20407	824.7	1.276	1.081	N/A
		20525	836.5	1.295	1.079	N/A
		20643	848.3	1.298	1.078	N/A
	16-QAM	20407	824.7	1.305	1.085	N/A
		20525	836.5	1.279	1.080	N/A
		20643	848.3	1.288	1.080	N/A
	64-QAM	20407	824.7	1.293	1.081	N/A
		20525	836.5	1.278	1.080	N/A
		20643	848.3	1.279	1.081	N/A
	256-QAM	20407	824.7	1.290	1.081	N/A
		20525	836.5	1.306	1.079	N/A
		20643	848.3	1.289	1.080	N/A
3	QPSK	20415	825.5	2.982	2.690	N/A
		20525	836.5	2.957	2.685	N/A
		20635	847.5	2.962	2.687	N/A
	16-QAM	20415	825.5	2.970	2.686	N/A
		20525	836.5	2.914	2.682	N/A
		20635	847.5	2.971	2.686	N/A
	64-QAM	20415	825.5	2.933	2.690	N/A
		20525	836.5	2.957	2.692	N/A
		20635	847.5	2.979	2.687	N/A
	256-QAM	20415	825.5	2.989	2.687	N/A
		20525	836.5	2.986	2.690	N/A
		20635	847.5	2.979	2.682	N/A
5	QPSK	20425	826.5	4.975	4.477	N/A
		20525	836.5	4.923	4.481	N/A
		20625	846.5	4.958	4.473	N/A
	16-QAM	20425	826.5	4.982	4.477	N/A
		20525	836.5	4.988	4.480	N/A
		20625	846.5	4.969	4.476	N/A
	64-QAM	20425	826.5	4.984	4.476	N/A
		20525	836.5	4.964	4.479	N/A
		20625	846.5	4.967	4.481	N/A
	256-QAM	20425	826.5	4.945	4.467	N/A
		20525	836.5	4.922	4.475	N/A
		20625	846.5	4.969	4.470	N/A

Bandwidth (MHz)	Modulation	Channel	Frequency (MHz)	Measure Level (MHz)		Limit (MHz)
				26dB BW	99% BW	
10	QPSK	20450.0	829.0	9.859	8.942	N/A
		20525.0	836.5	9.771	8.926	N/A
		20600.0	844.0	9.748	8.936	N/A
	16-QAM	20450.0	829.0	9.740	8.927	N/A
		20525.0	836.5	9.797	8.949	N/A
		20600.0	844.0	9.782	8.947	N/A
	64-QAM	20450.0	829.0	9.919	8.929	N/A
		20525.0	836.5	9.785	8.937	N/A
		20600.0	844.0	9.652	8.922	N/A
	256-QAM	20450.0	829.0	9.768	8.944	N/A
		20525.0	836.5	9.794	8.934	N/A
		20600.0	844.0	9.714	8.910	N/A

QPSK_CH20407_1.4M_6RB0

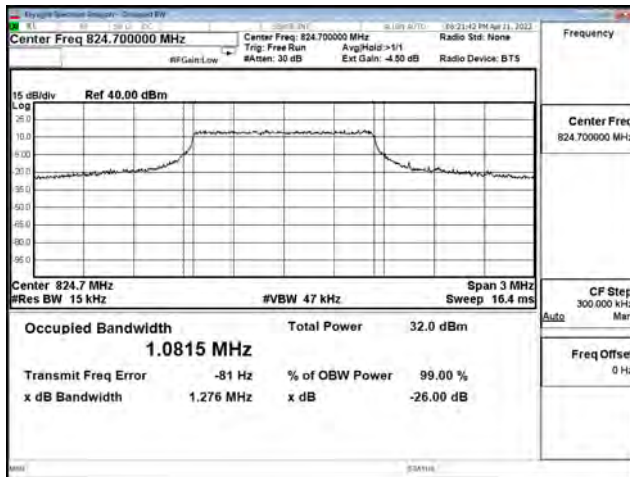

QPSK_CH20525_1.4M_6RB0

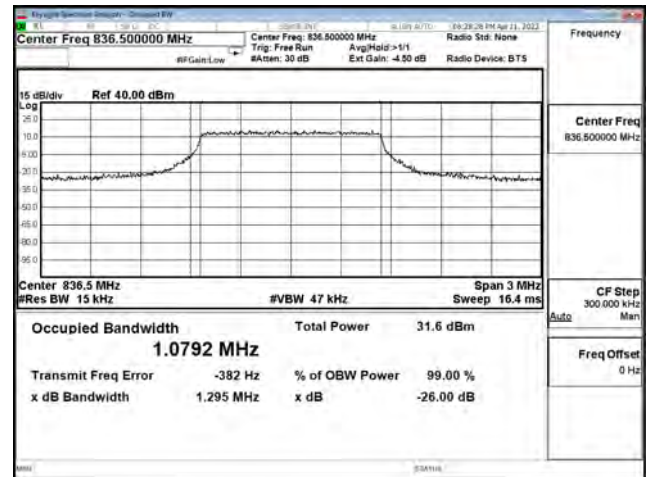

QPSK_CH20643_1.4M_6RB0

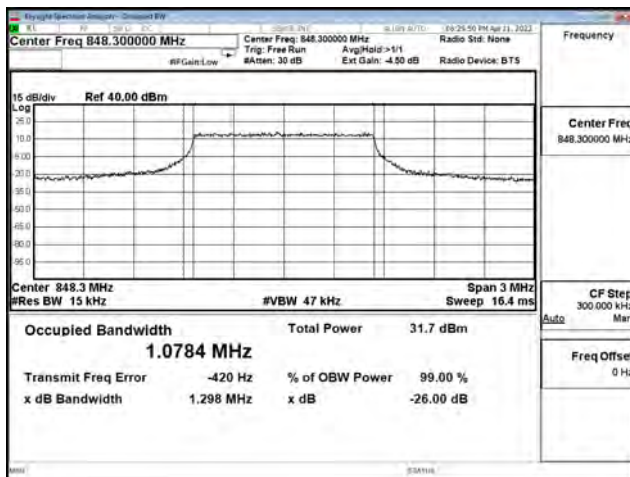

16QAM_CH20407_1.4M_6RB0

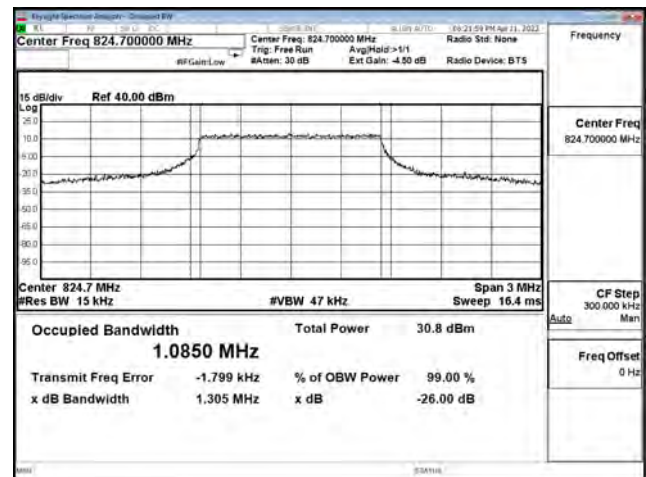

16-QAM_CH20525_1.4M_6RB0

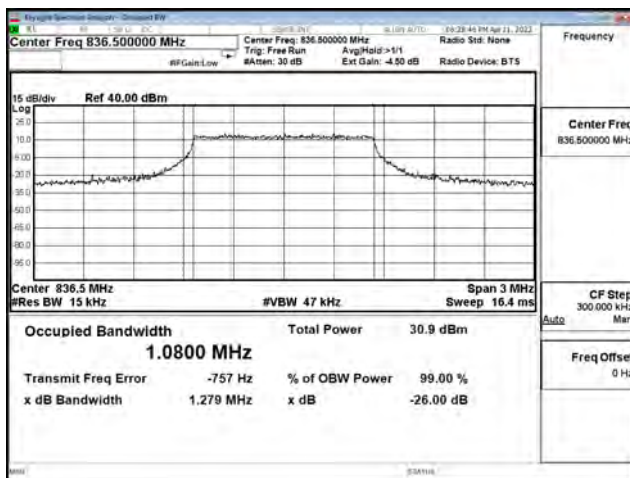

16-QAM_CH20643_1.4M_6RB0

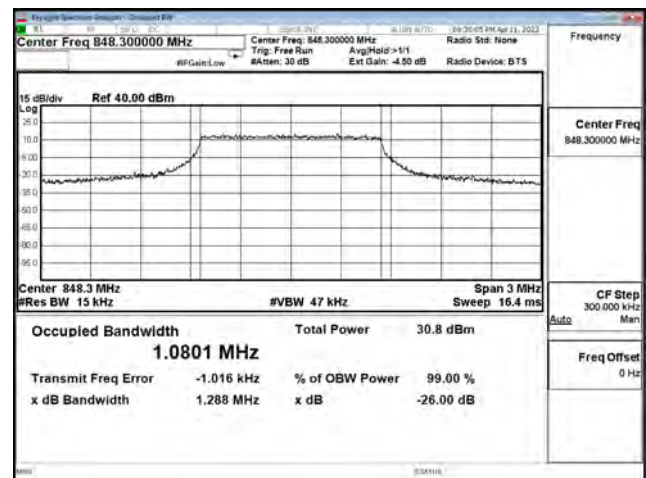

64-QAM_CH20407_1.4M_6RB0

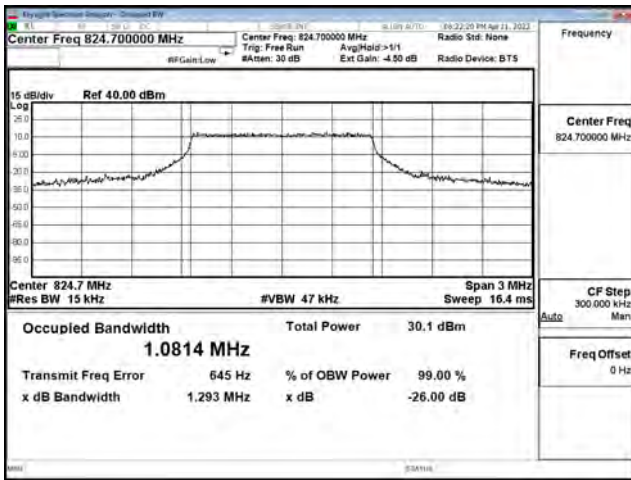

64-QAM_CH20525_1.4M_6RB0

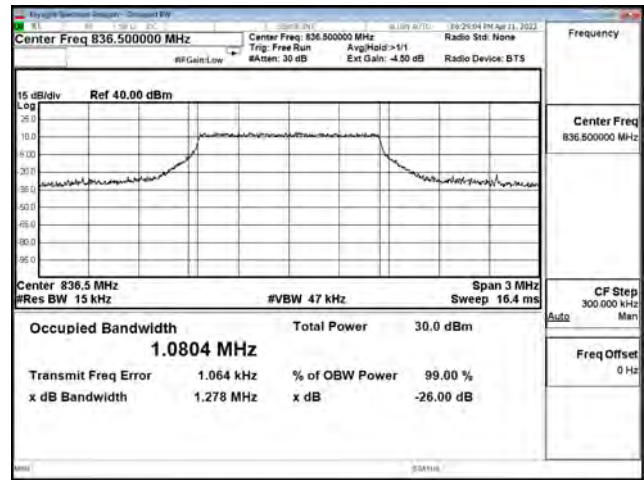

64-QAM_CH20643_1.4M_6RB0

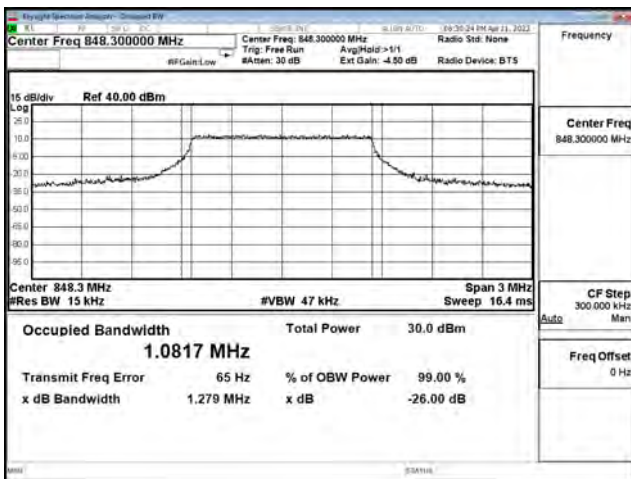

256-QAM_CH20407_1.4M_6RB0

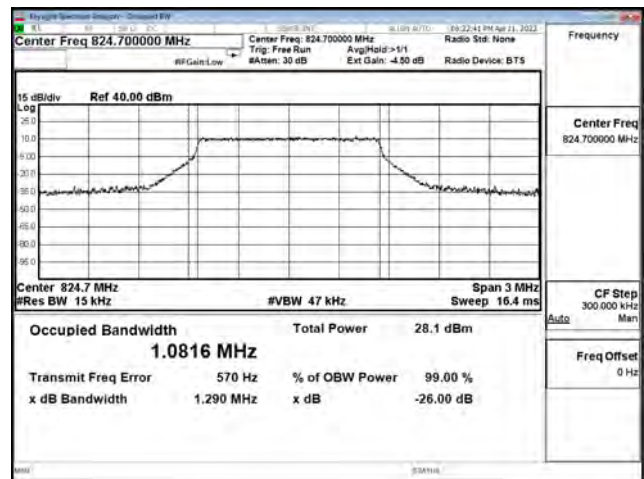

256-QAM_CH20525_1.4M_6RB0

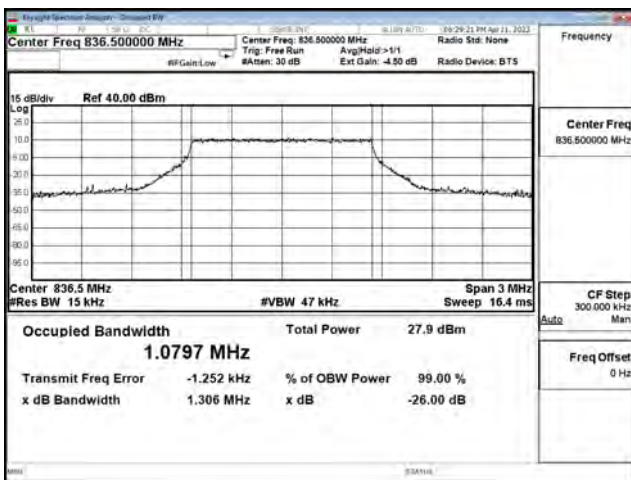

256-QAM_CH20643_1.4M_6RB0

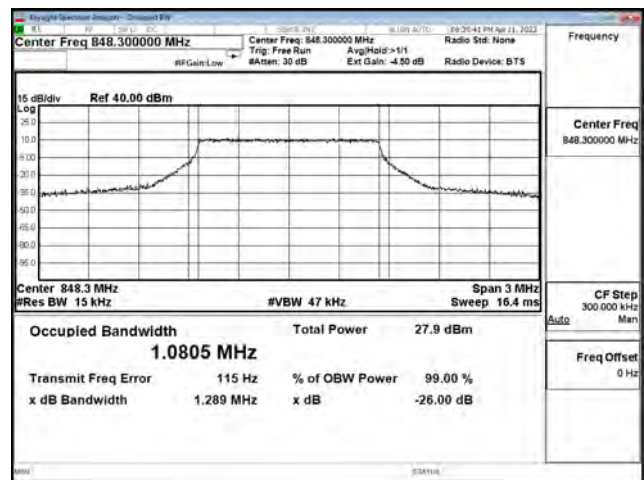

QPSK_CH20415_3M_15RB0

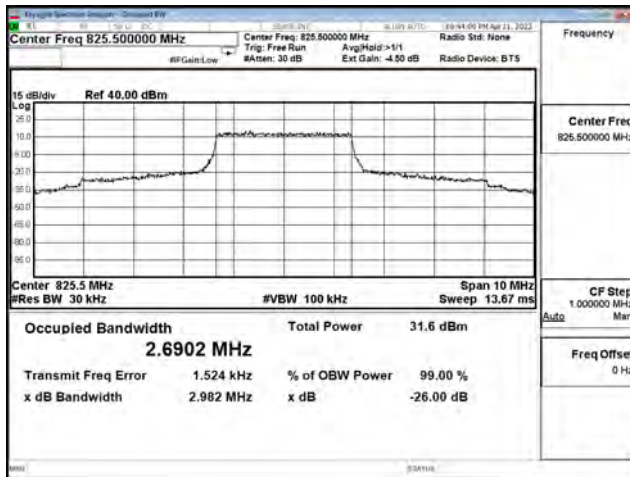

QPSK_CH20525_3M_15RB0

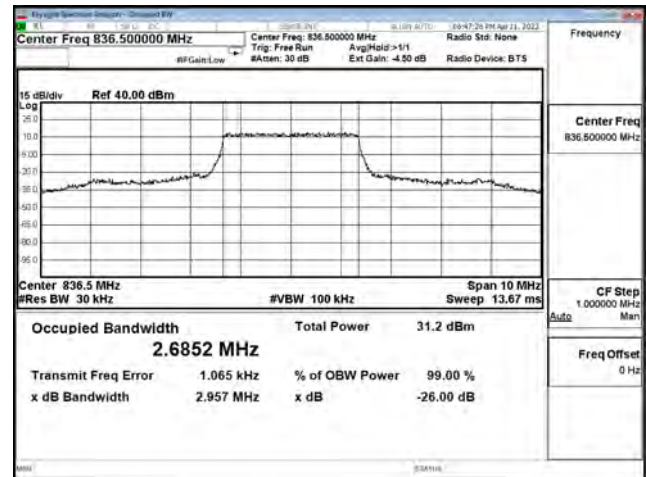

QPSK_CH20635_3M_15RB0

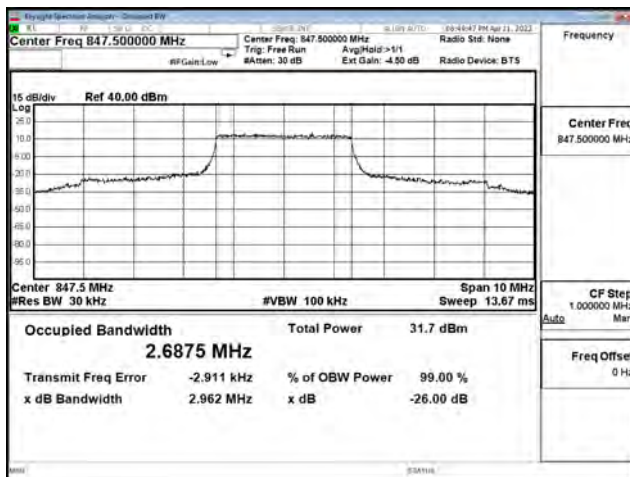

16QAM_CH20415_3M_15RB0

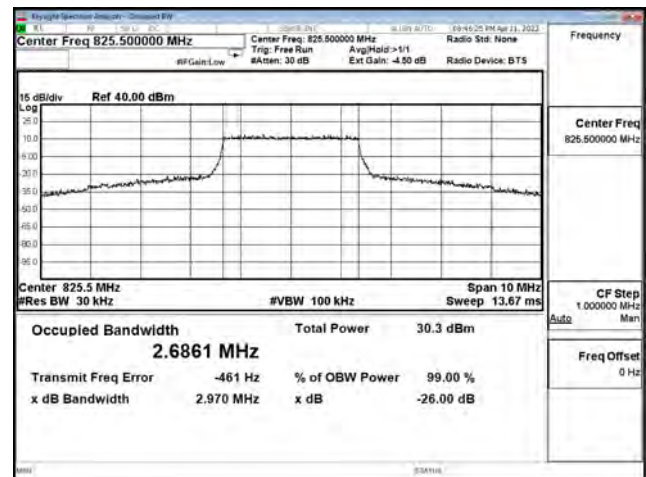

16-QAM_CH20525_3M_15RB0

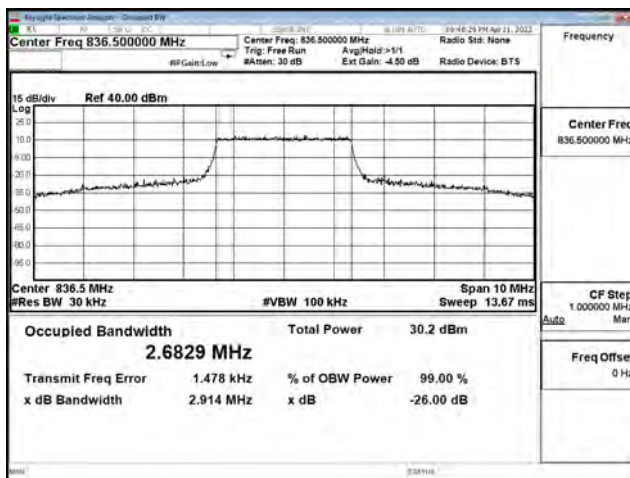

16-QAM_CH20635_3M_15RB0

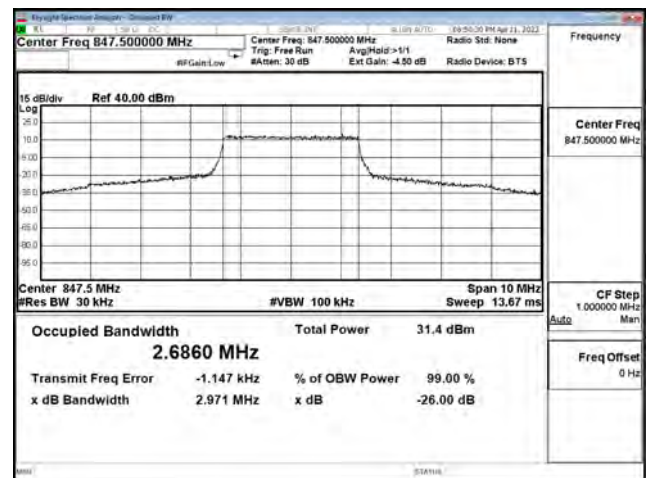

64-QAM_CH20415_3M_15RB0

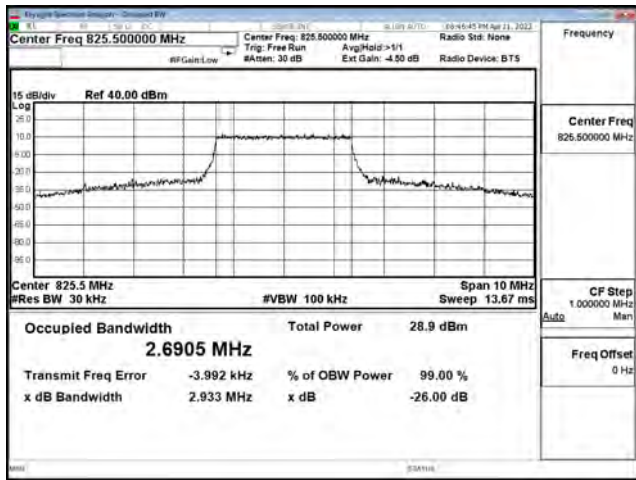

64-QAM_CH20525_3M_15RB0

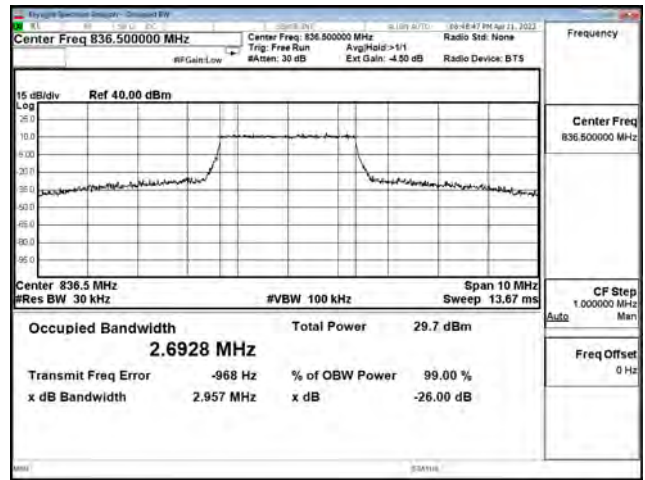

64-QAM_H20635_3M_15RB0

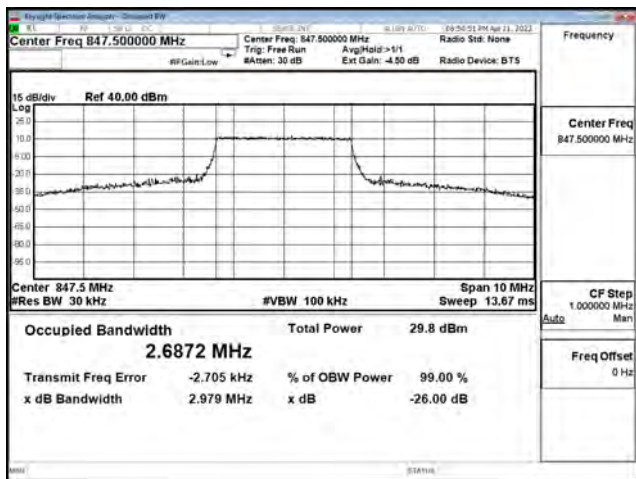

256-QAM_CH20415_3M_15RB0

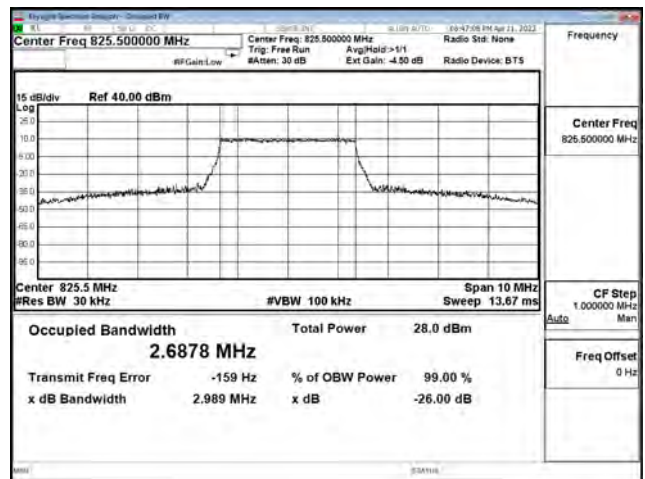

256-QAM_CH20525_3M_15RB0

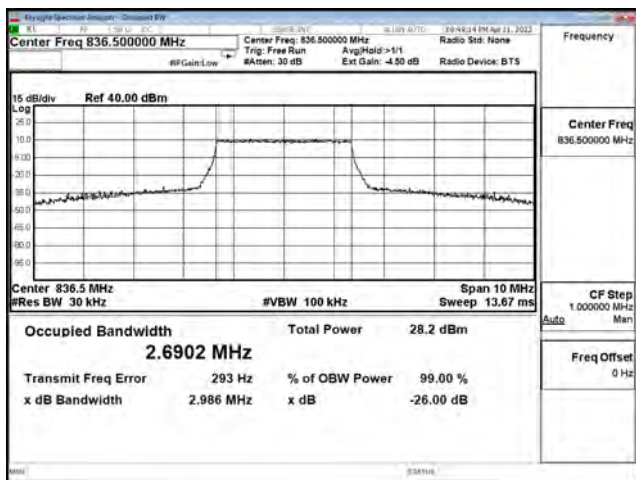

256-QAM_CH20635_3M_15RB0

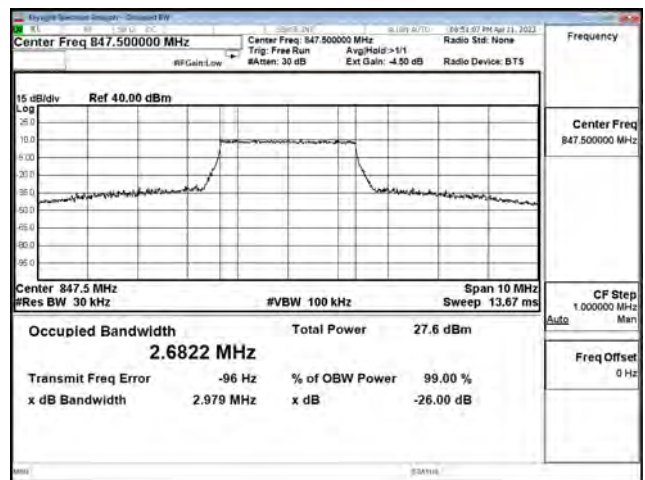

QPSK_CH20425_5M_5RB0

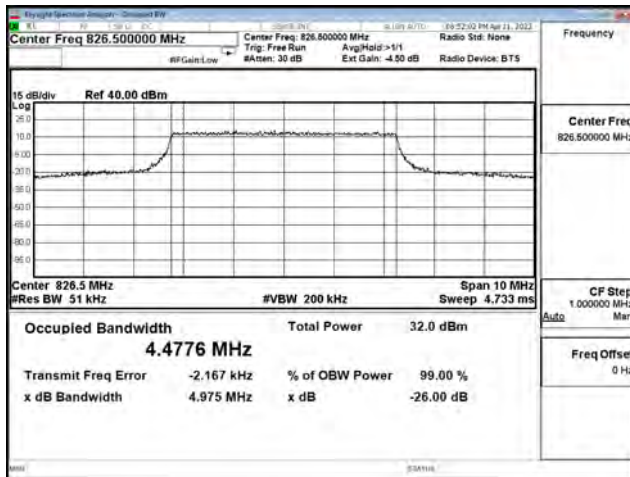

QPSK_CH20525_5M_25RB0

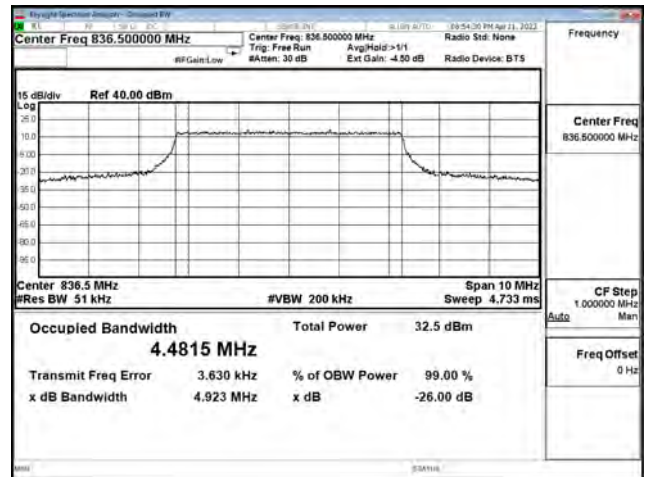

QPSK_CH20625_5M_25RB0

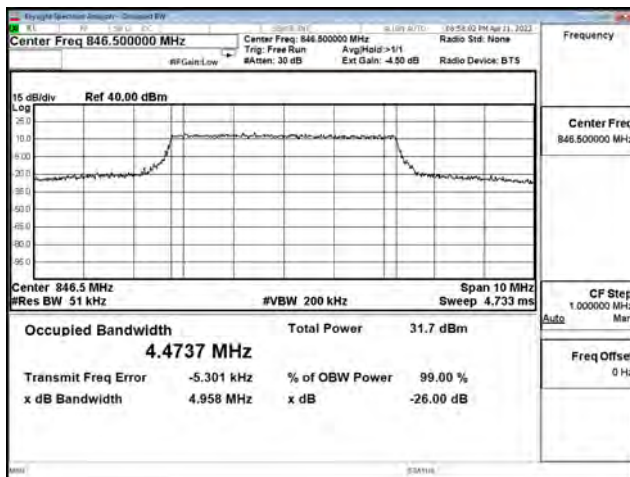

16-QAM_CH20425_5M_25RB0

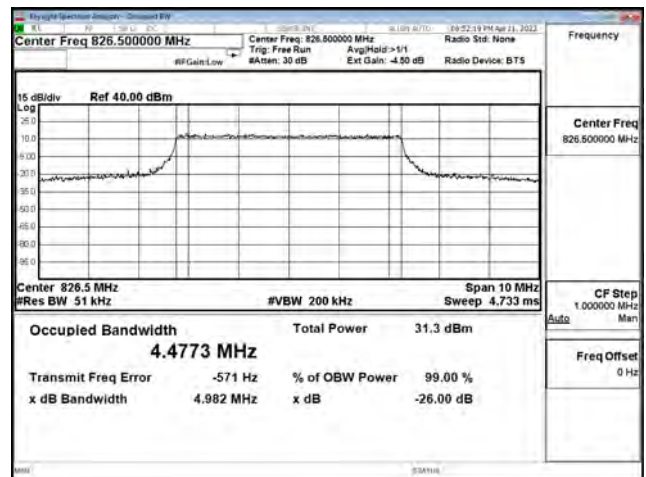

16-QAM_CH20525_5M_25RB0

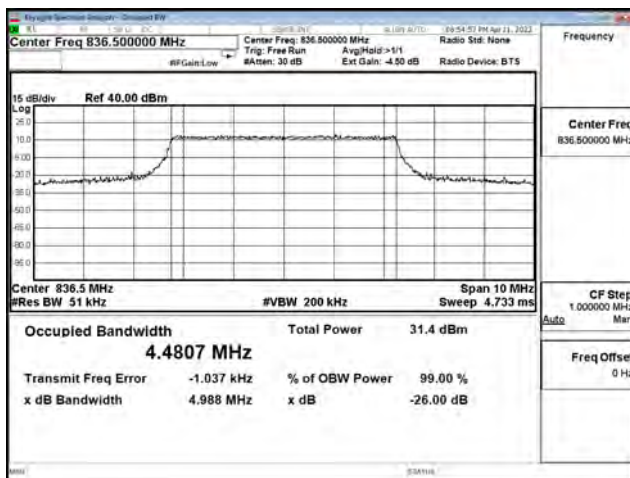

16-QAM_CH20625_5M_25RB0

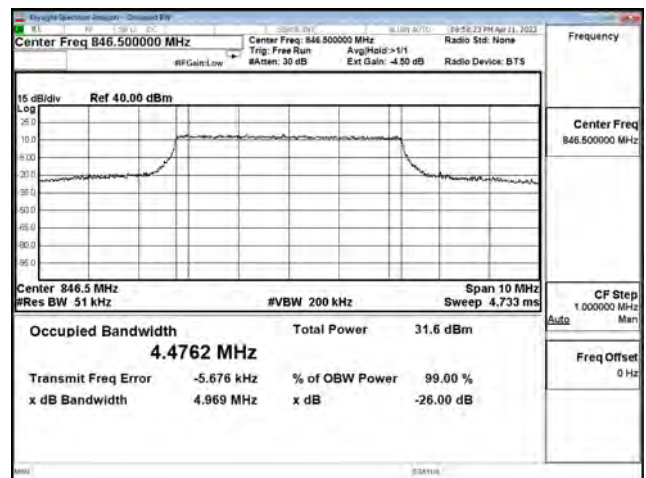

64-QAM_CH20425_5M_25RB0

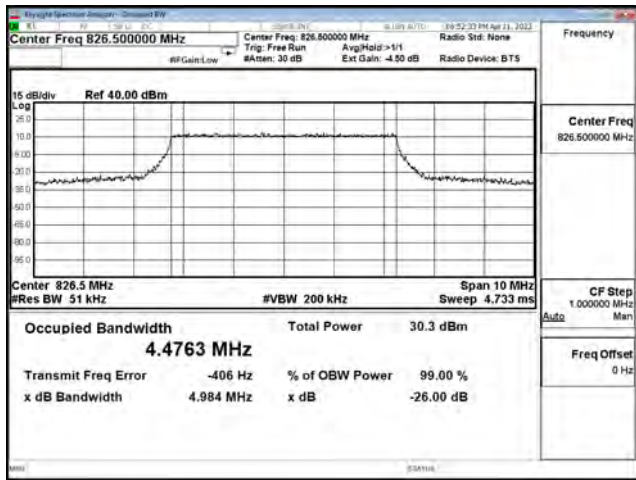

64-QAM_CH20525_5M_25RB0

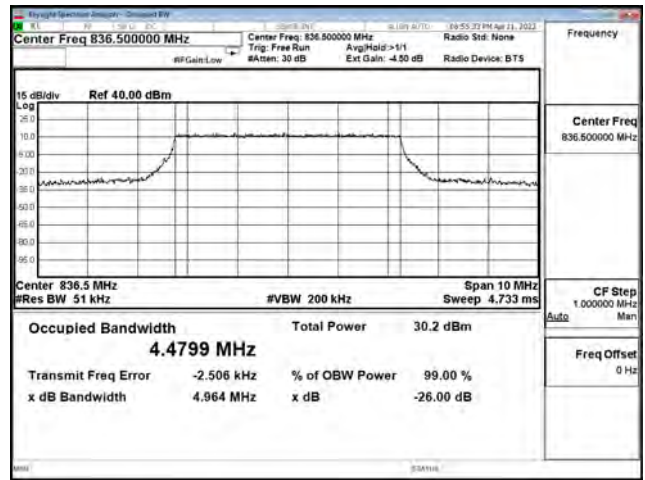

64-QAM_CH20625_5M_25RB0

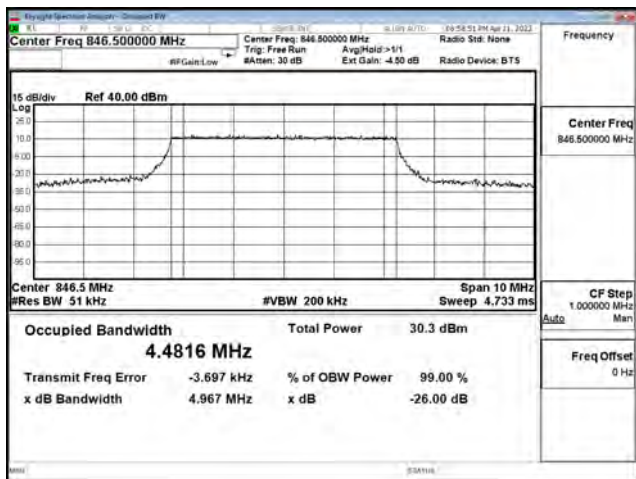

256-QAM_CH20425_5M_25RB0

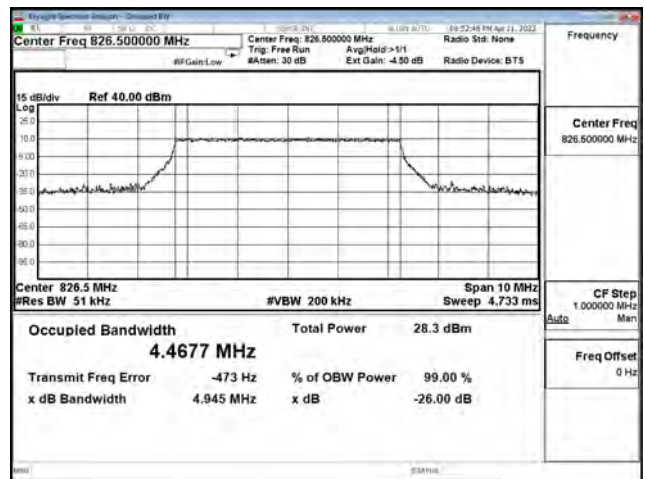

256-QAM_CH20525_5M_25RB0

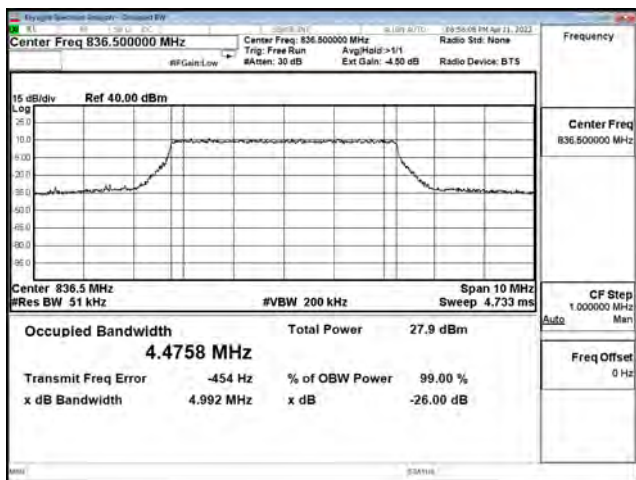

256-QAM_CH20625_5M_25RB0

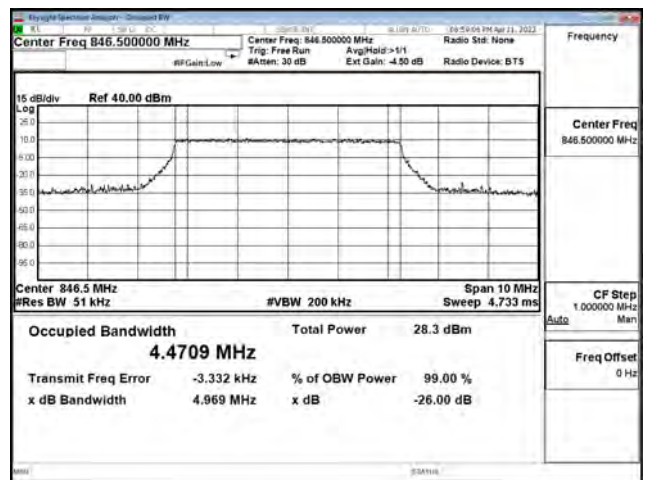

QPSK_CH20450_10M_50RB0

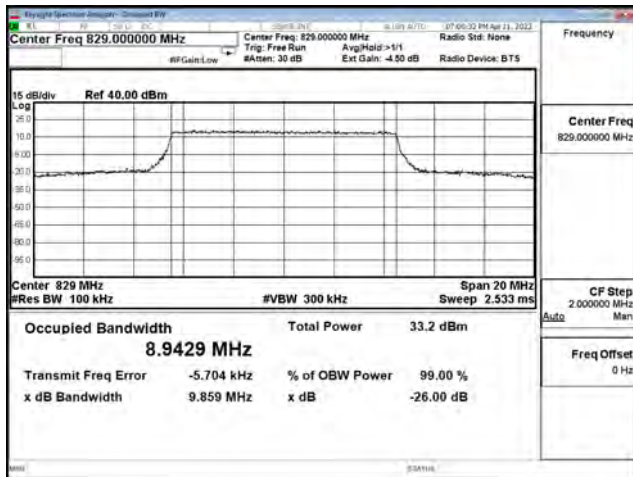

QPSK_CH20525_10M_50RB0

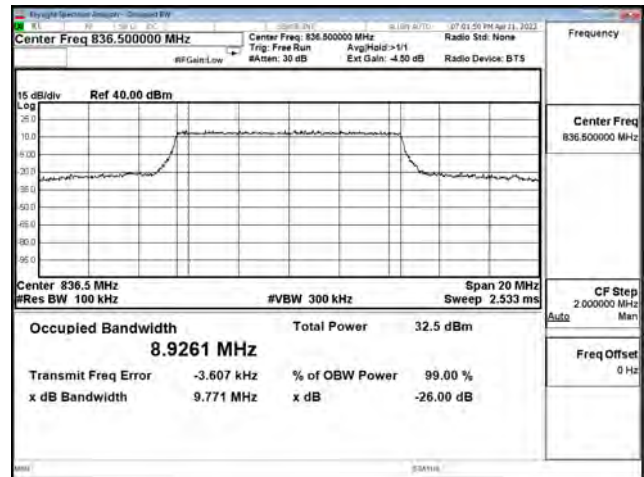

QPSK_CH20600_10M_50RB0

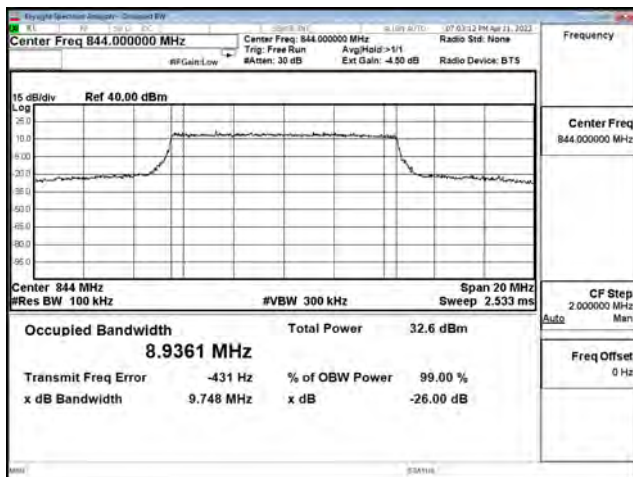

16-QAM_CH20450_10M_50RB0

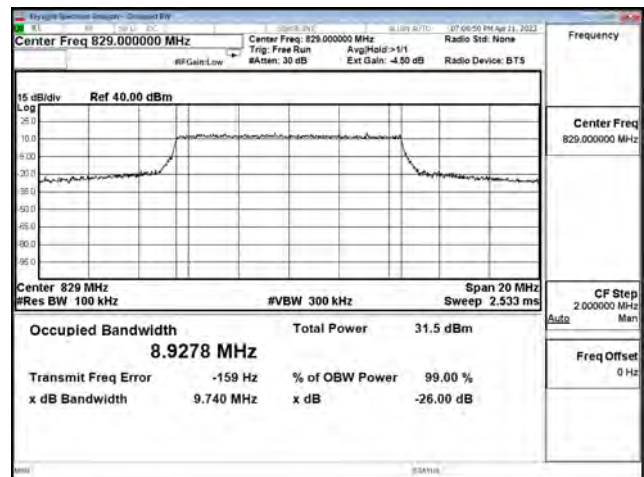

16-QAM_CH20525_10M_50RB0

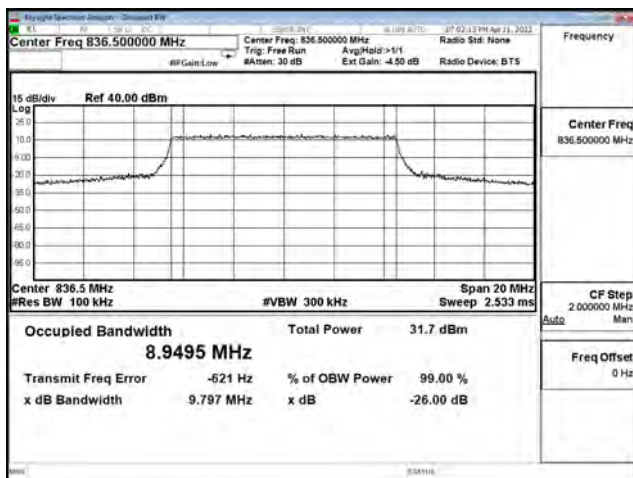

16-QAM_CH20600_10M_50RB0

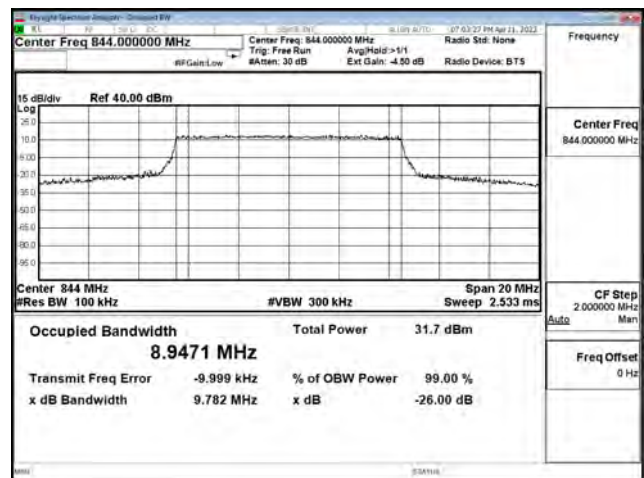

64-QAM_CH20450_10M_50RB0

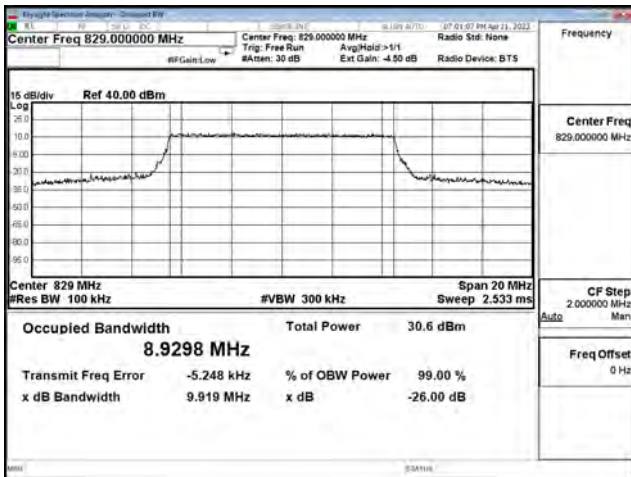

64-QAM_CH20525_10M_50RB0

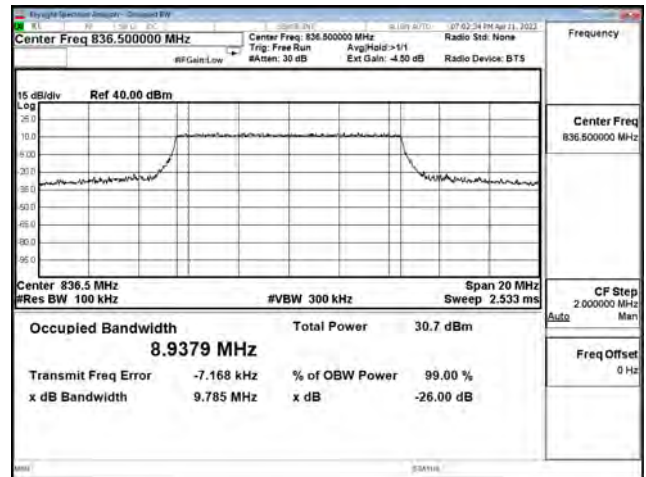

64-QAM_CH20600_10M_50RB0

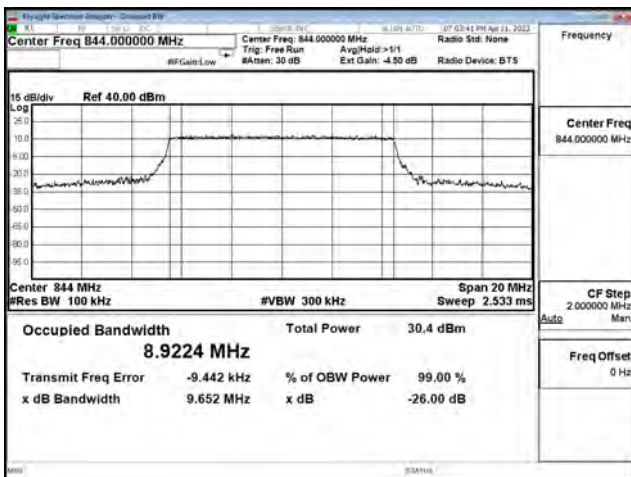

256-QAM_CH20450_10M_50RB0

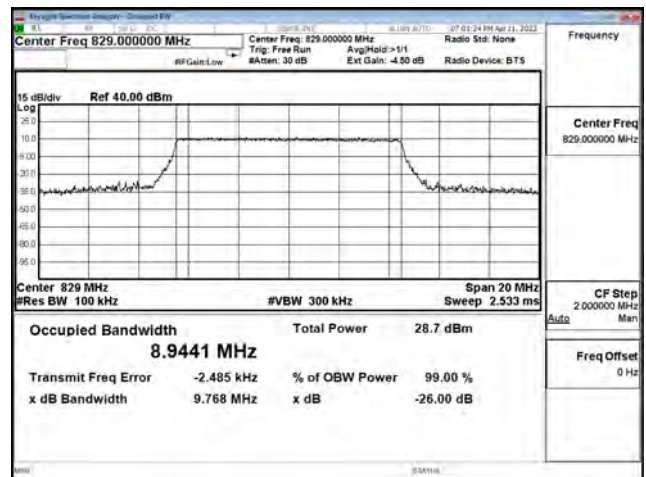

256-QAM_CH20525_10M_50RB0

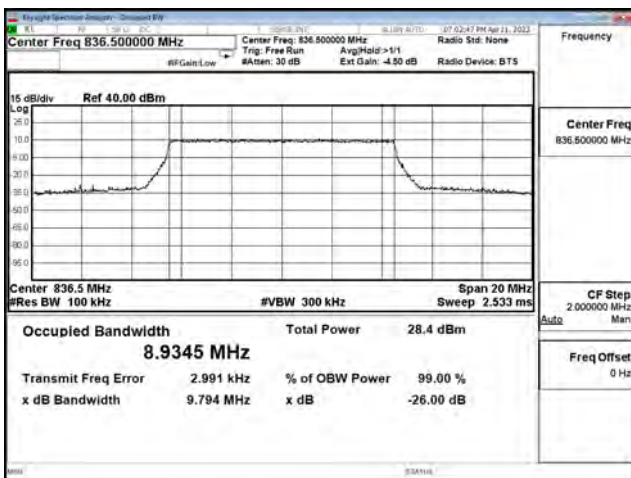

256-QAM_CH20600_10M_50RB0

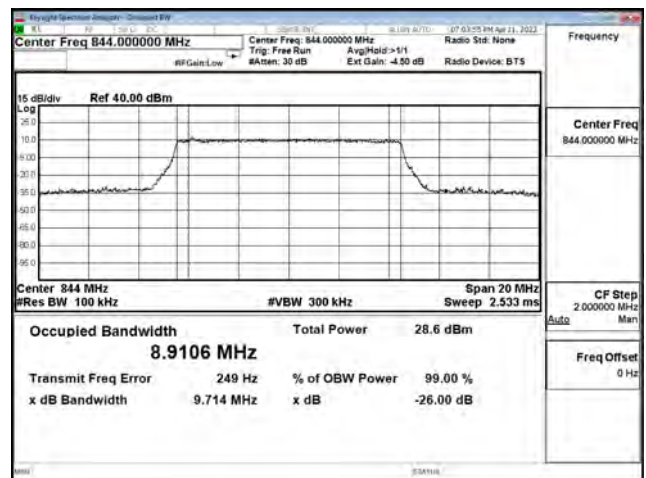

Mode 3: LTE Band 13

Bandwidth (MHz)	Modulation	Channel	Frequency (MHz)	Measure Level (MHz)		Limit (MHz)
				26dB BW	99% BW	
5	QPSK	23205	779.5	4.968	4.474	N/A
		23230	782	4.986	4.760	N/A
		23255	784.5	4.940	4.471	N/A
	16-QAM	23205	779.5	4.949	4.473	N/A
		23230	782	4.952	4.480	N/A
		23255	784.5	4.962	4.460	N/A
	64-QAM	23205	779.5	4.957	4.474	N/A
		23230	782	4.834	4.474	N/A
		23255	784.5	4.982	4.471	N/A
	256-QAM	23205	779.5	4.924	4.472	N/A
		23230	782	4.989	4.477	N/A
		23255	784.5	4.949	4.463	N/A
10	QPSK	23230	782	9.596	8.912	N/A
	16-QAM	23230	782	9.505	8.907	N/A
	64-QAM	23230	782	9.538	8.911	N/A
	256-QAM	23230	782	9.643	8.927	N/A

QPSK_CH23205_5M_25RB0

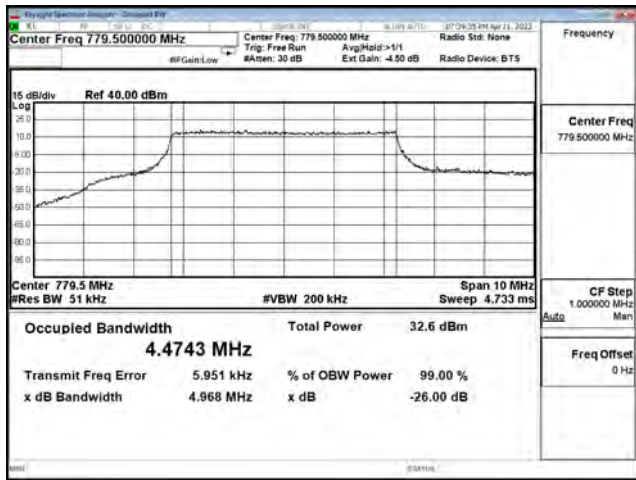

QPSK_CH23230_5M_25RB0

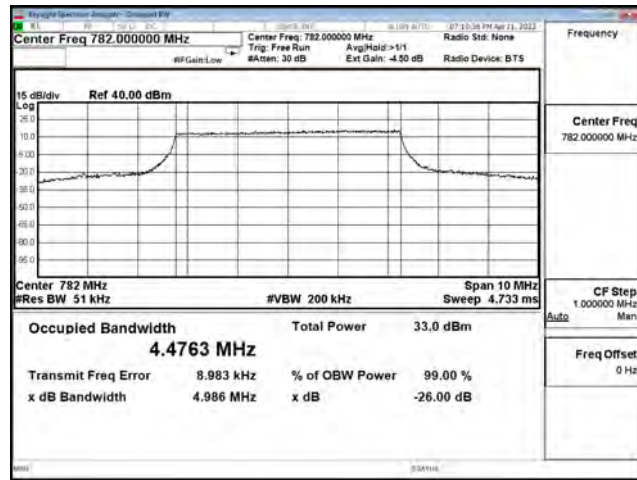

CH23255_5M_25RB0

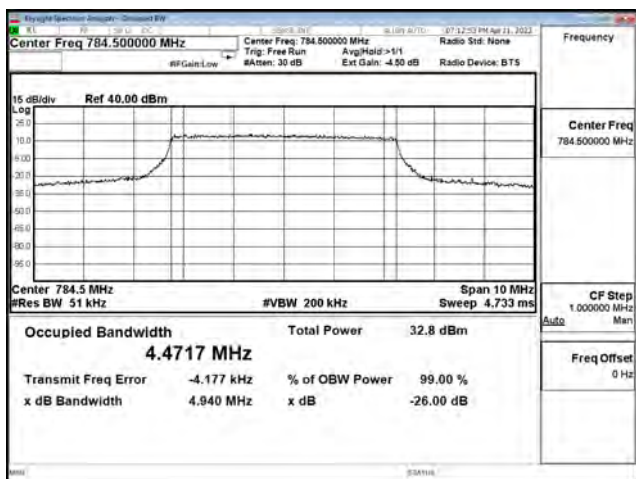

16-QAM_CH23205_5M_25RB0

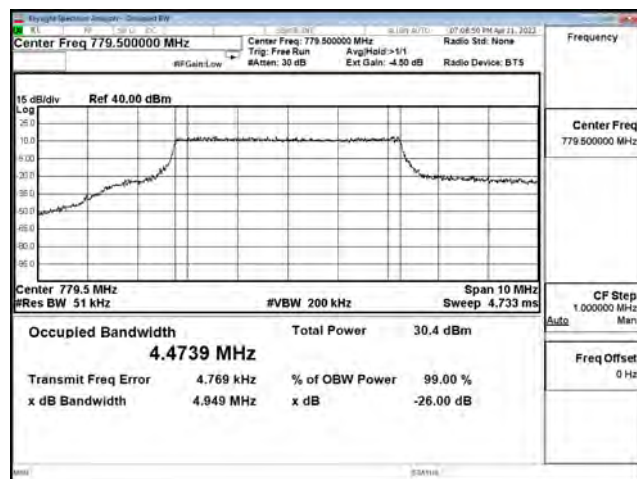

16-QAM_CH23230_5M_25RB0

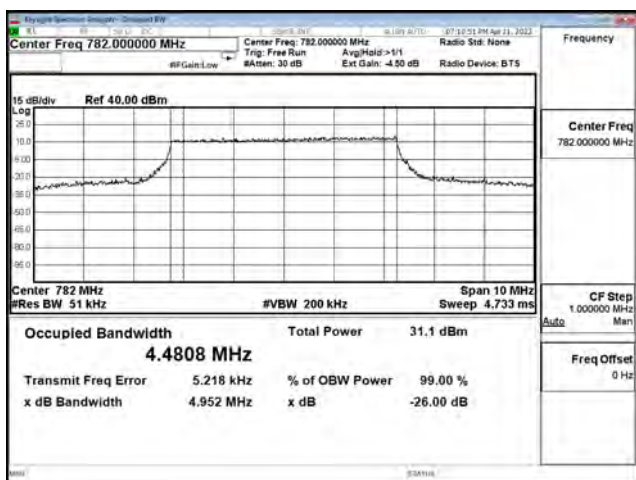

16-QAM_CH23255_5M_25RB0

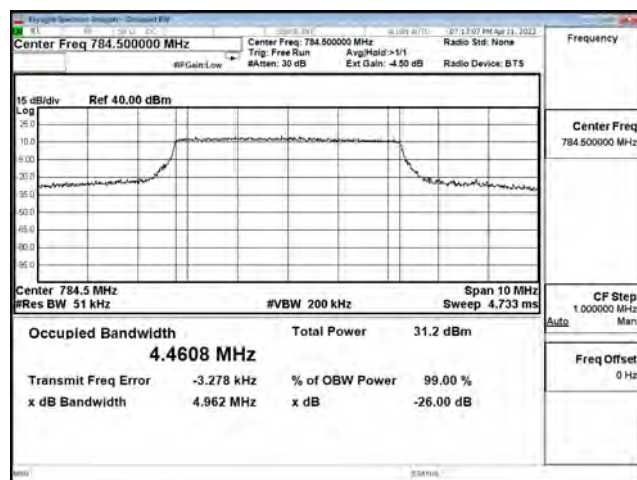

64-QAM_CH23205_5M_25RB0

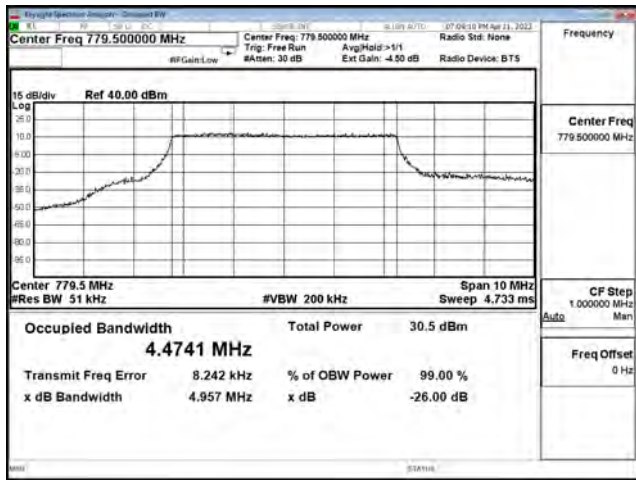

64-QAM_CH23230_5M_25RB0

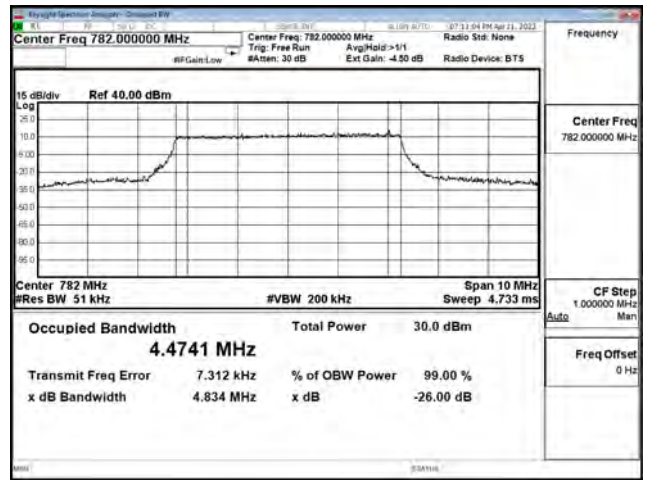

64-QAM_CH23255_5M_25RB0

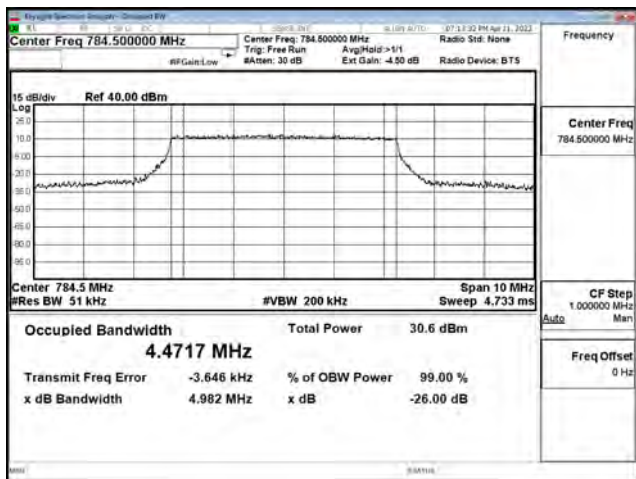

256-QAM_CH23205_5M_25RB0

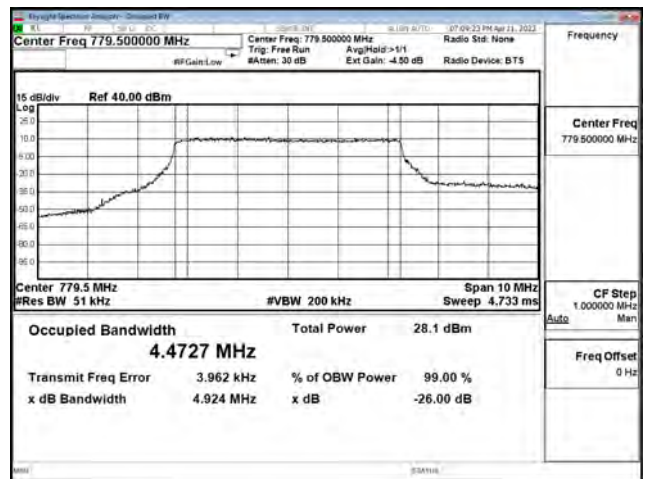

256-QAM_CH23230_5M_25RB0

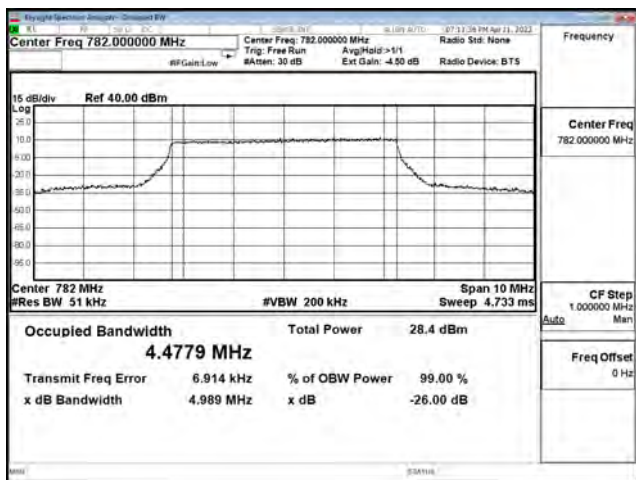

256-QAM_CH23255_5M_25RB0

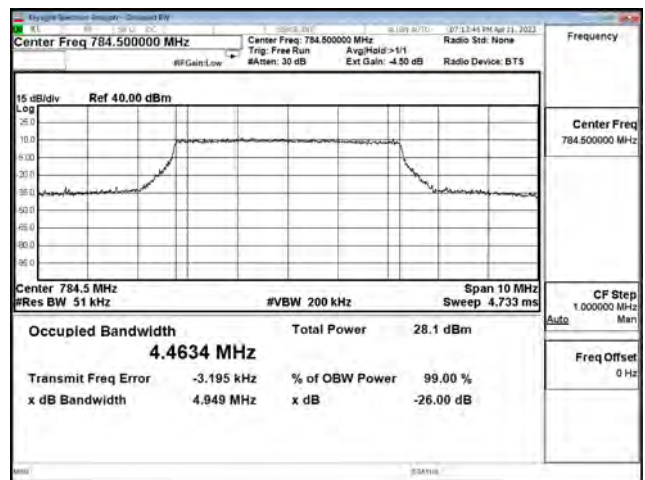

QPSK_CH23230_10M_50RB

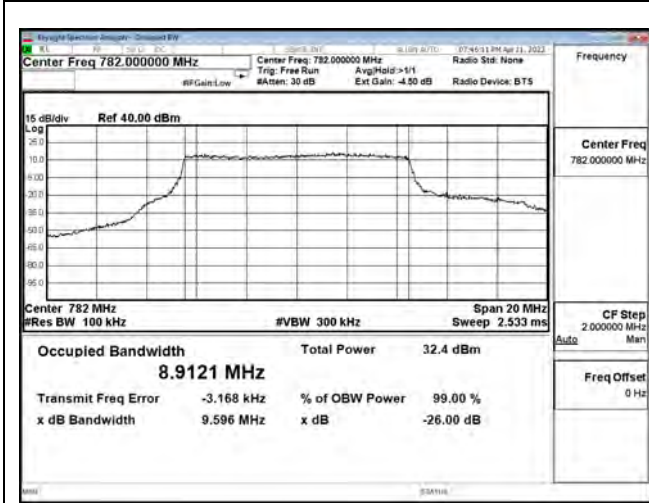

16-QAM_CH23230_10M_50RB0

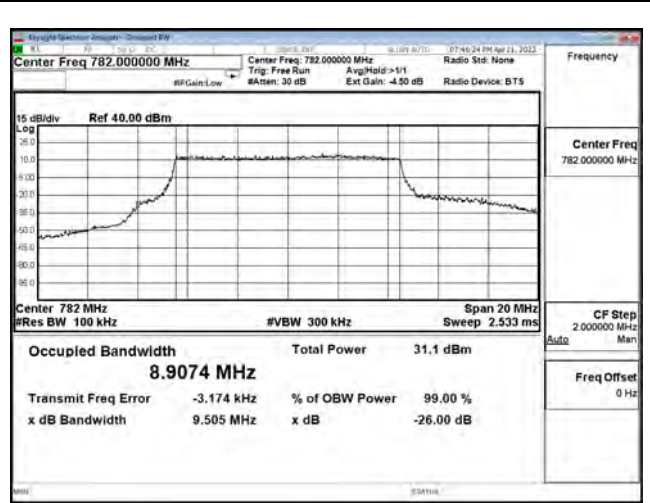

64-QAM_CH23230_10M_50RB0

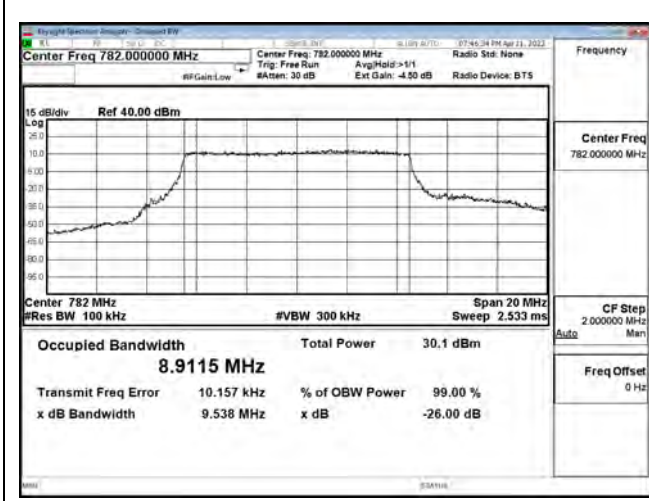

256-QAM_CH23230_10M_50RB0

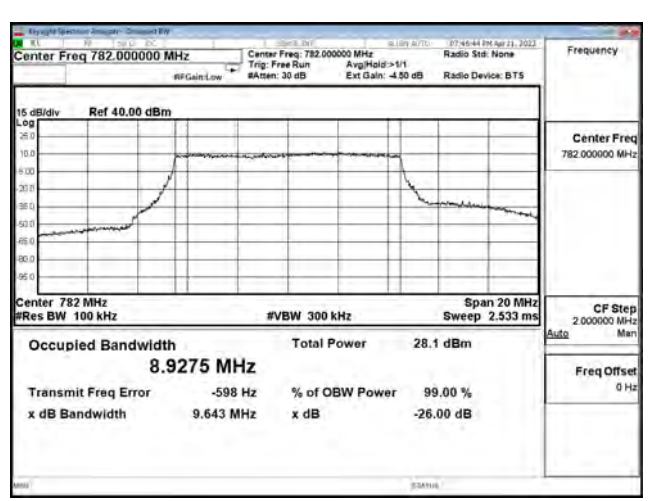

Mode 4: LTE Band 66

Bandwidth (MHz)	Modulation	Channel	Frequency (MHz)	Measure Level (MHz)		Limit (MHz)
				26dB BW	99% BW	
1.4	QPSK	131979	1710.7	1.286	1.079	N/A
		132322	1745	1.302	1.081	N/A
		132665	1779.3	1.295	1.079	N/A
	16-QAM	131979	1710.7	1.298	1.082	N/A
		132322	1745	1.315	1.082	N/A
		132665	1779.3	1.307	1.081	N/A
	64-QAM	131979	1710.7	1.301	1.080	N/A
		132322	1745	1.289	1.084	N/A
		132665	1779.3	1.281	1.078	N/A
	256-QAM	131979	1710.7	1.313	1.080	N/A
		132322	1745	1.309	1.081	N/A
		132665	1779.3	1.305	1.079	N/A
3	QPSK	131987	1711.5	2.978	2.687	N/A
		132322	1745	2.954	2.691	N/A
		132657	1778.5	2.991	2.686	N/A
	16-QAM	131987	1711.5	2.985	2.686	N/A
		132322	1745	2.972	2.682	N/A
		132657	1778.5	2.943	2.691	N/A
	64-QAM	131987	1711.5	2.987	2.682	N/A
		132322	1745	2.970	2.686	N/A
		132657	1778.5	2.971	2.688	N/A
	256-QAM	131987	1711.5	2.973	2.688	N/A
		132322	1745	2.978	2.687	N/A
		132657	1778.5	2.944	2.692	N/A
5	QPSK	131997	1712.5	4.953	4.479	N/A
		132322	1745	4.970	4.474	N/A
		132647	1777.5	4.972	4.474	N/A
	16-QAM	131997	1712.5	4.952	4.476	N/A
		132322	1745	4.966	4.478	N/A
		132647	1777.5	4.972	4.473	N/A
	64-QAM	131997	1712.5	4.966	4.471	N/A
		132322	1745	4.945	4.483	N/A
		132647	1777.5	4.980	4.469	N/A
	256-QAM	131997	1712.5	4.954	4.478	N/A
		132322	1745	4.960	4.473	N/A
		132647	1777.5	4.979	4.478	N/A

Bandwidth (MHz)	Modulation	Channel	Frequency (MHz)	Measure Level (MHz)		Limit (MHz)
				26dB BW	99% BW	
10	QPSK	132022	1715	9.787	8.941	N/A
		132322	1745	9.845	8.942	N/A
		132622	1775	9.858	8.947	N/A
	16-QAM	132022	1715	9.816	8.961	N/A
		132322	1745	9.834	8.947	N/A
		132622	1775	9.797	8.956	N/A
	64-QAM	132022	1715	9.844	8.947	N/A
		132322	1745	9.742	8.937	N/A
		132622	1775	9.811	8.954	N/A
	256-QAM	132022	1715	9.880	8.956	N/A
		132322	1745	9.789	8.955	N/A
		132622	1775	9.815	8.943	N/A
15	QPSK	132047	1717.5	14.760	13.429	N/A
		132322	1745	14.690	13.430	N/A
		132597	1772.5	14.540	13.420	N/A
	16-QAM	132047	1717.5	14.590	13.427	N/A
		132322	1745	14.630	13.428	N/A
		132597	1772.5	14.590	13.447	N/A
	64-QAM	132047	1717.5	14.600	13.398	N/A
		132322	1745	14.600	13.422	N/A
		132597	1772.5	14.550	13.442	N/A
	256-QAM	132047	1717.5	14.620	13.420	N/A
		132322	1745	14.630	13.426	N/A
		132597	1772.5	14.580	13.428	N/A
20	QPSK	132072	1720	19.460	17.881	N/A
		132322	1745	19.440	17.878	N/A
		132572	1770	19.440	17.887	N/A
	16-QAM	132072	1720	19.450	17.878	N/A
		132322	1745	19.290	17.894	N/A
		132572	1770	19.390	17.883	N/A
	64-QAM	132072	1720	19.280	17.887	N/A
		132322	1745	19.310	17.897	N/A
		132572	1770	19.340	17.866	N/A
	256-QAM	132072	1720	19.360	17.878	N/A
		132322	1745	19.340	17.880	N/A
		132572	1770	19.280	17.871	N/A

QPSK_CH131979_1.4M_6RB0

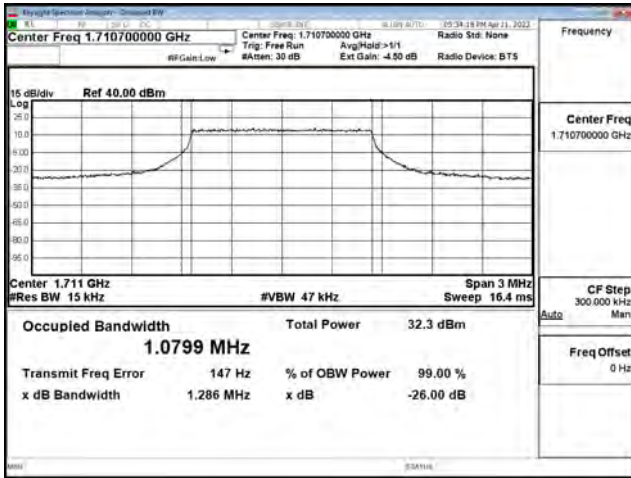

QPSK_CH132322_1.4M_6RB0

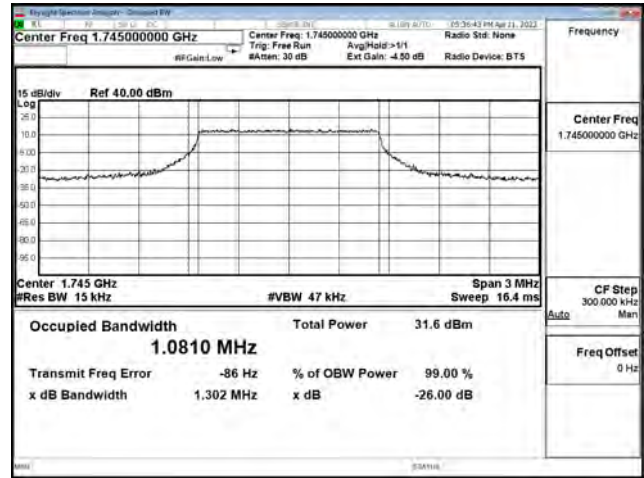

QPSK CH132665_1.4M_6RB0

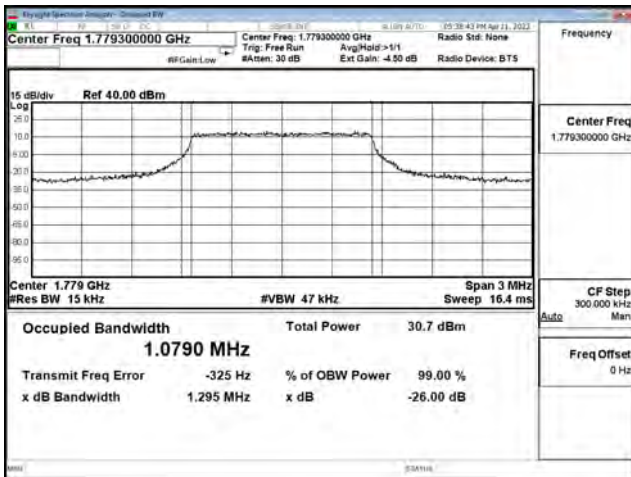

16-QAM_CH131979_1.4M_6RB0

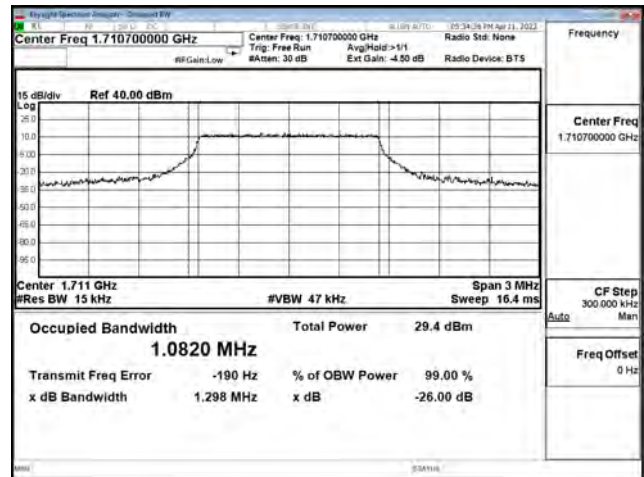

16-QAM_CH132322_1.4M_6RB0

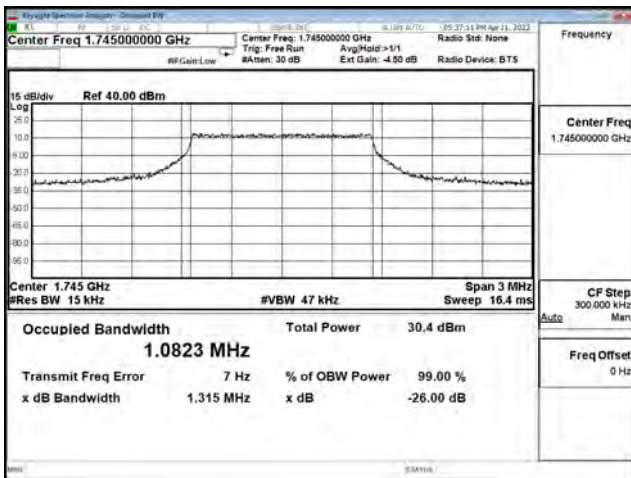

16-QAM_CH132665_1.4M_6RB0

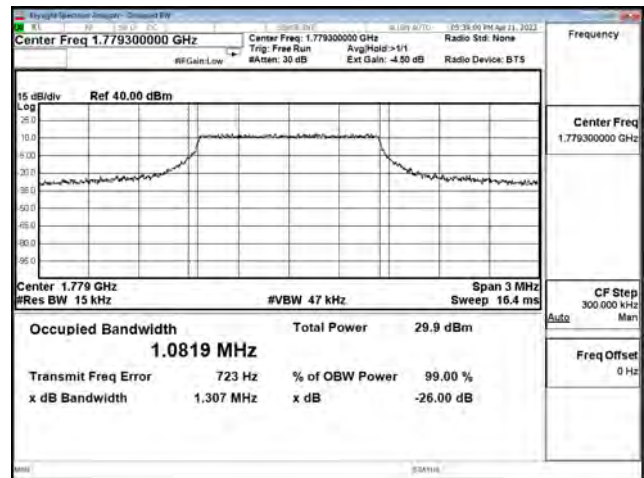

64-QAM_CH131979_1.4M_6RB0

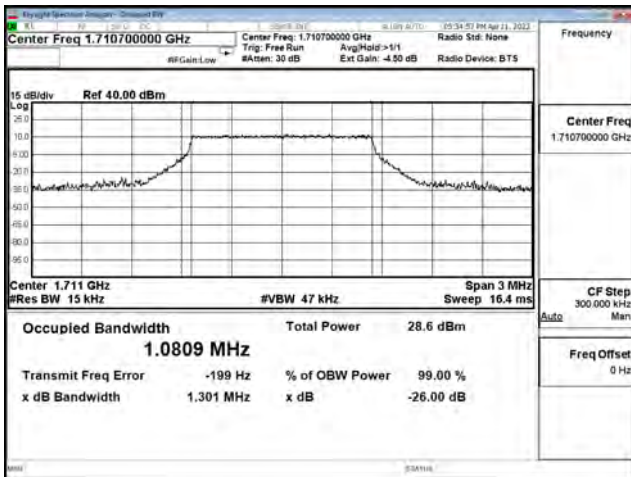

64-QAM_CH132322_1.4M_6RB0

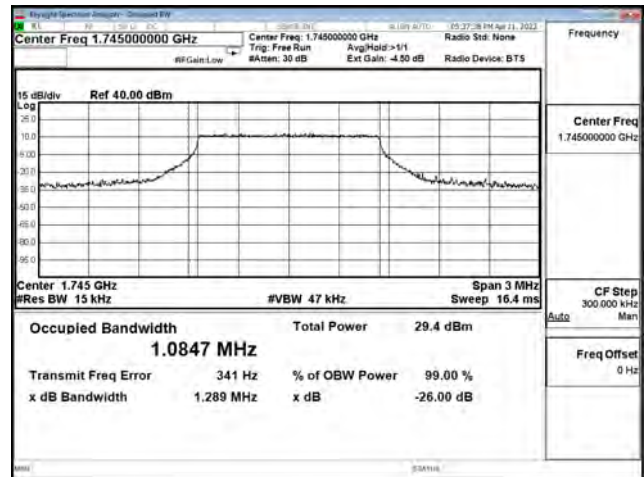

64-QAM_CH132665_1.4M_6RB0

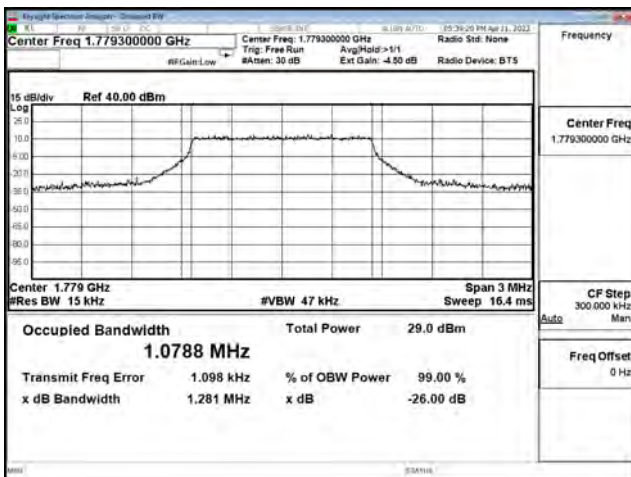

256-QAM_CH131979_1.4M_6RB0

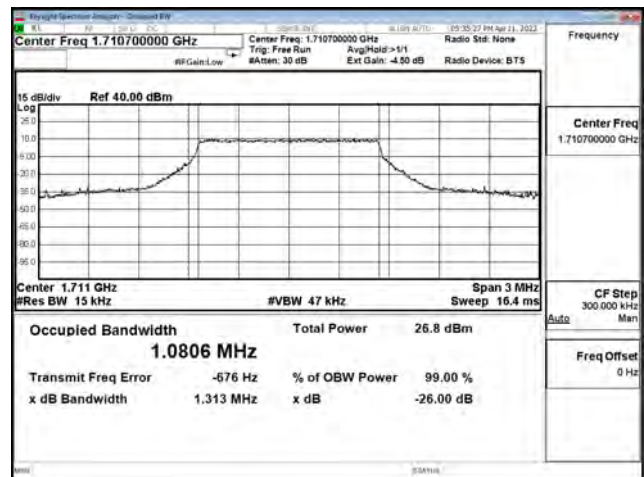

256-QAM_CH132322_1.4M_6RB0

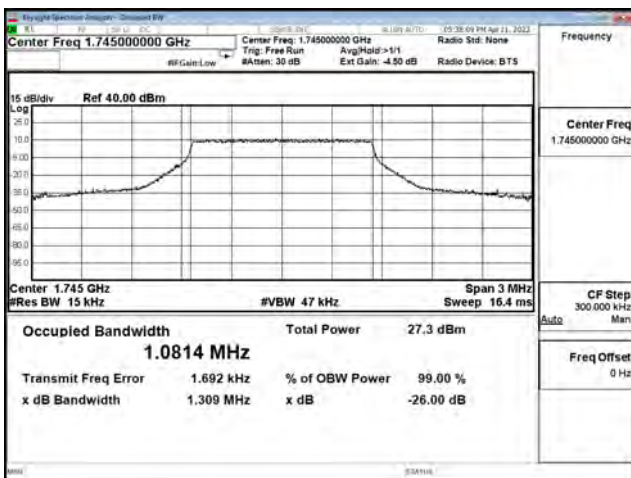

256-QAM_CH132665_1.4M_6RB0

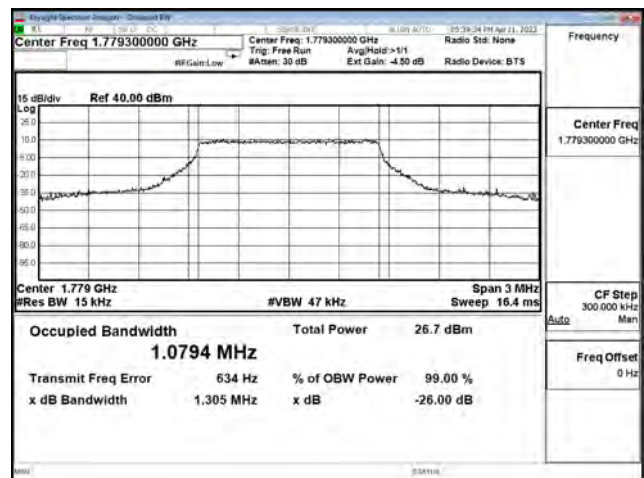

QPSK_CH131987_3M_15RB0

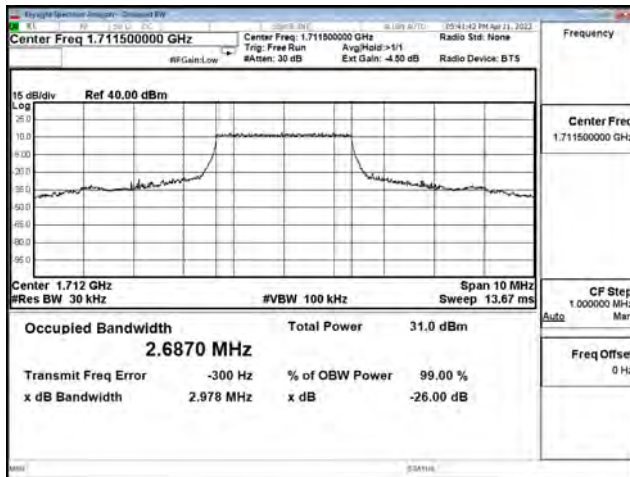

QPSK_CH132322_3M_15RB0

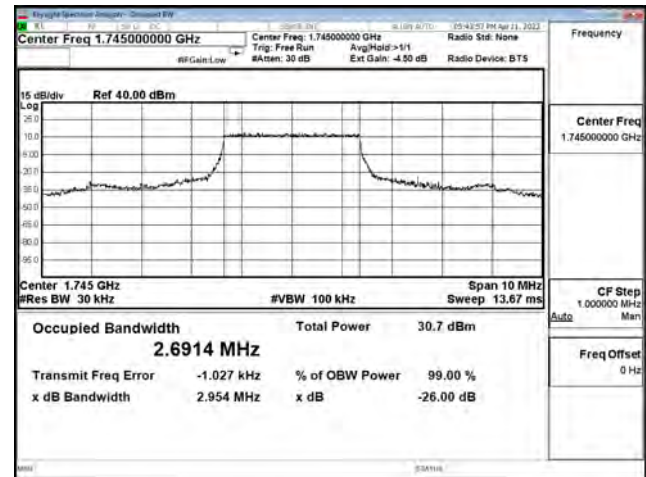

QPSK_CH132657_3M_15RB0

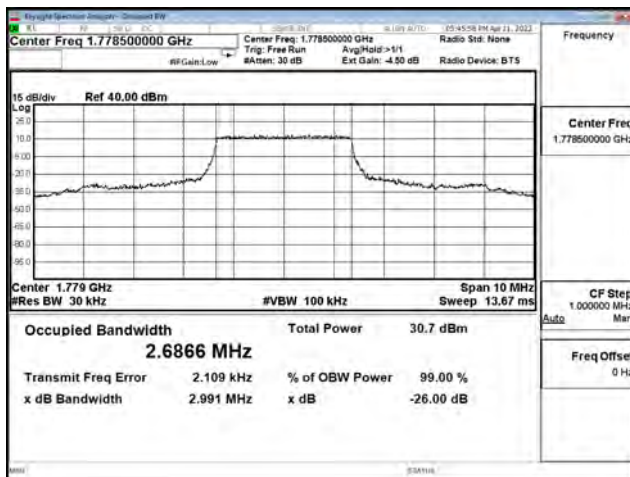

16-QAM_CH131987_3M_15RB0

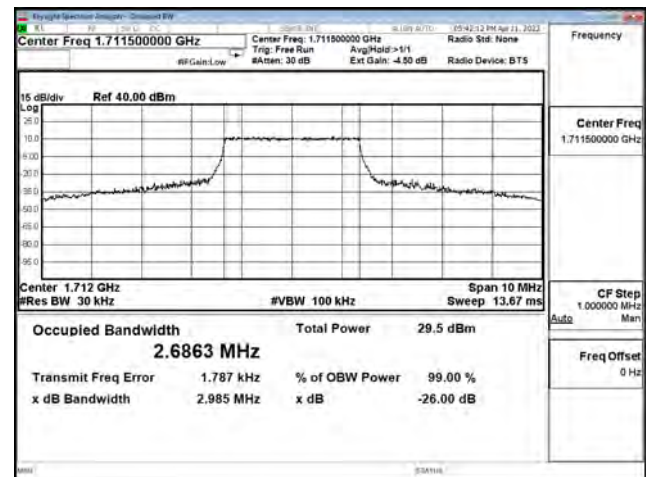

16-QAM_CH132322_3M_15RB0

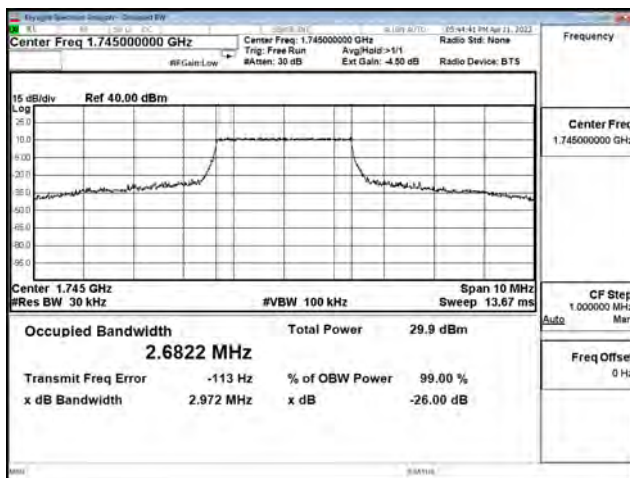

16-QAM_CH132657_3M_15RB0

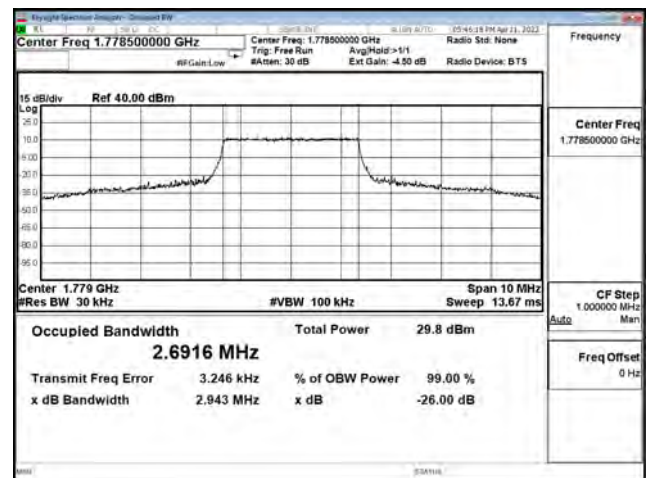

64-QAM_CH131987_3M_15RB0

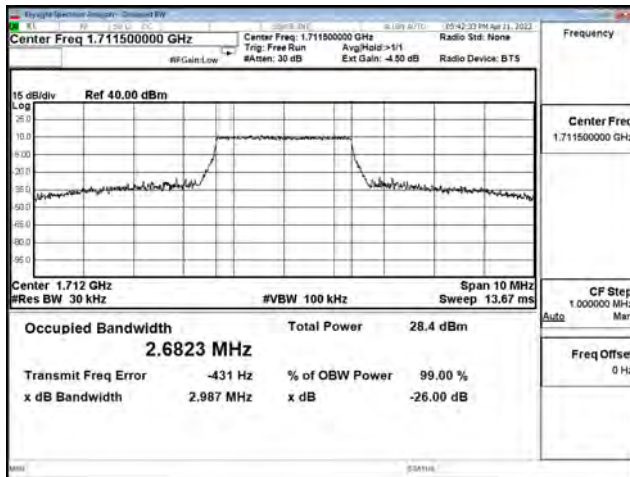

64-QAM_CH132322_3M_15RB0

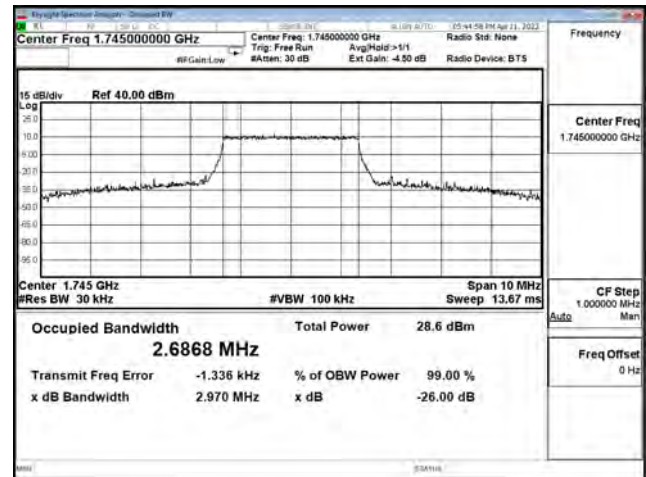

64-QAM_CH132657_3M_15RB0

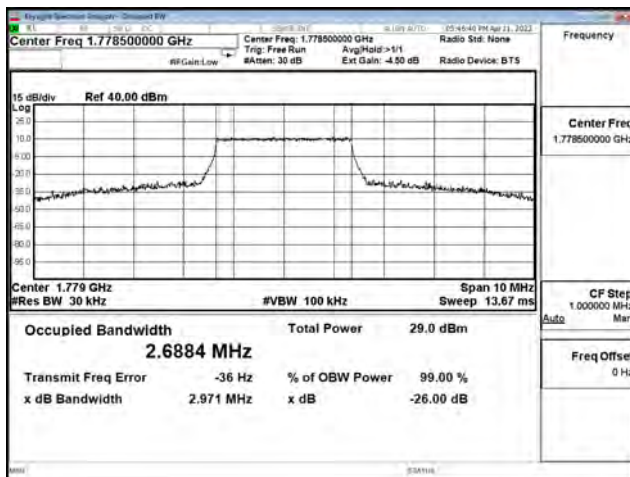

256-QAM_CH131987_3M_15RB0

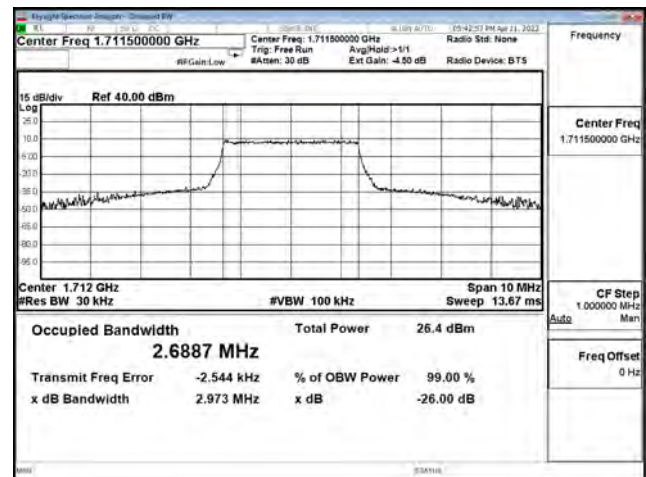

256-QAM_CH132322_3M_15RB0

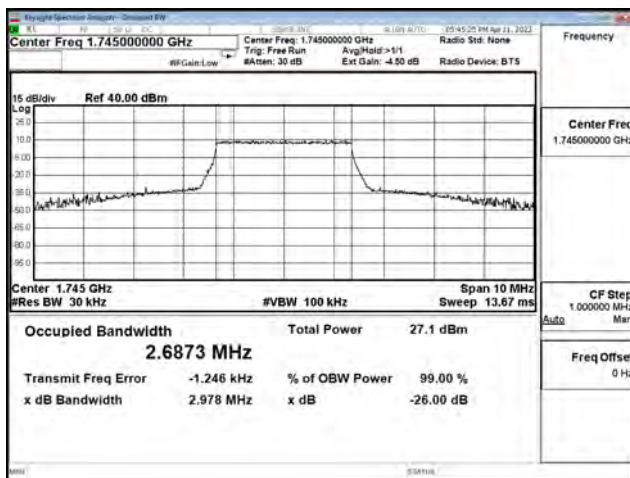

256-QAM_CH132657_3M_15RB0

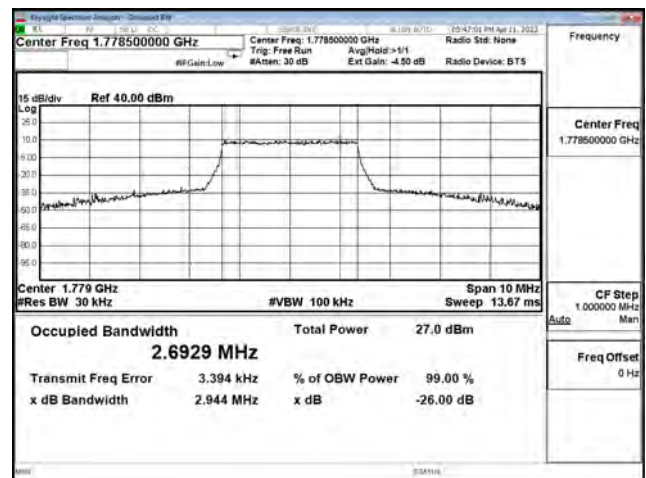

QPSK_CH131997_5M_25RB0

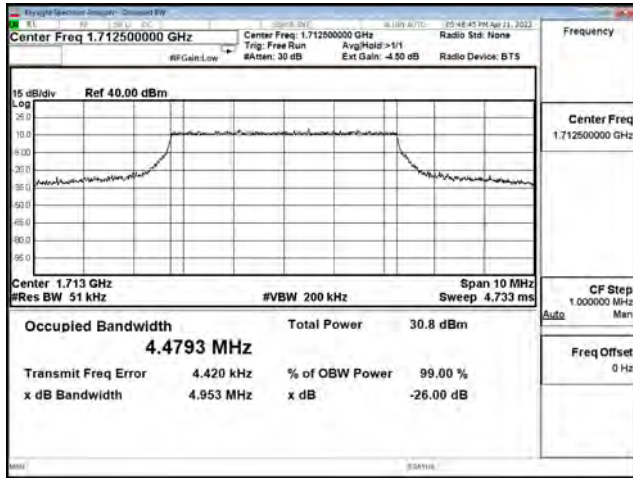

QPSK_CH132322_5M_25RB0

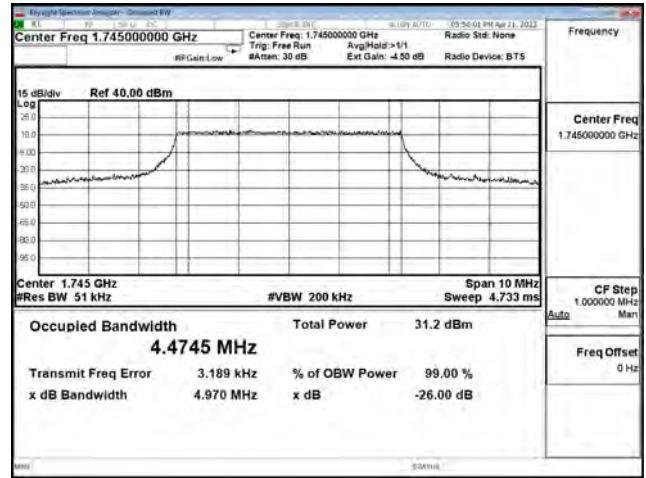

CH132647_5M_25RB0

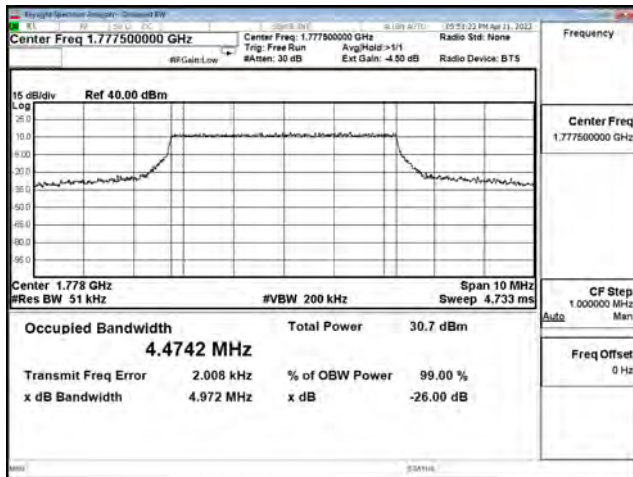

16-QAM_CH131997_5M_25RB0

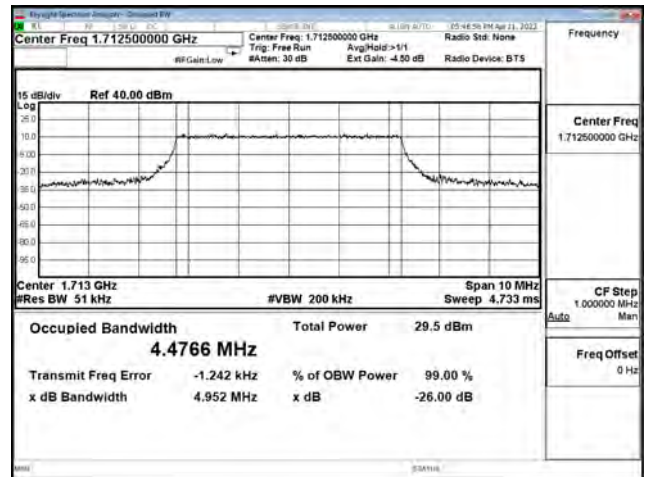

16-QAM_CH132322_5M_25RB0

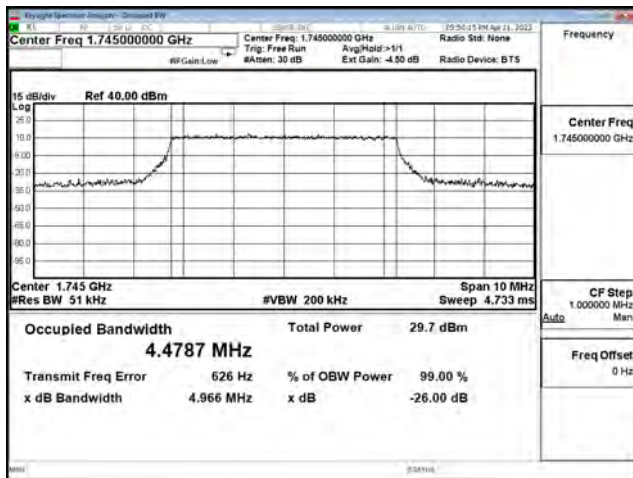

16-QAM_CH132647_5M_25RB0

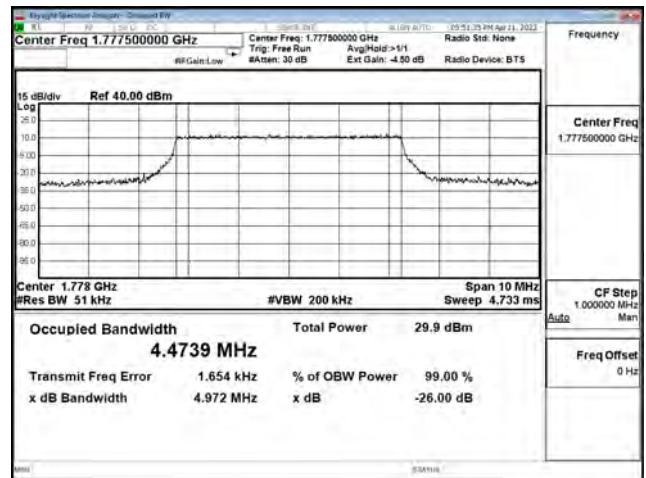

64-QAM_CH131997_5M_25RB0

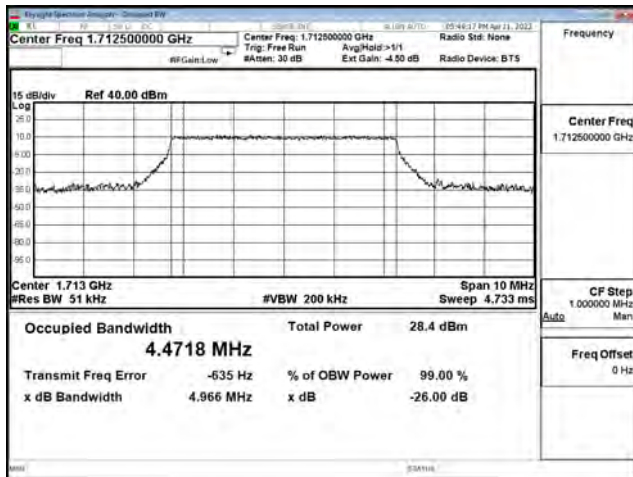

64-QAM_CH132322_5M_25RB0

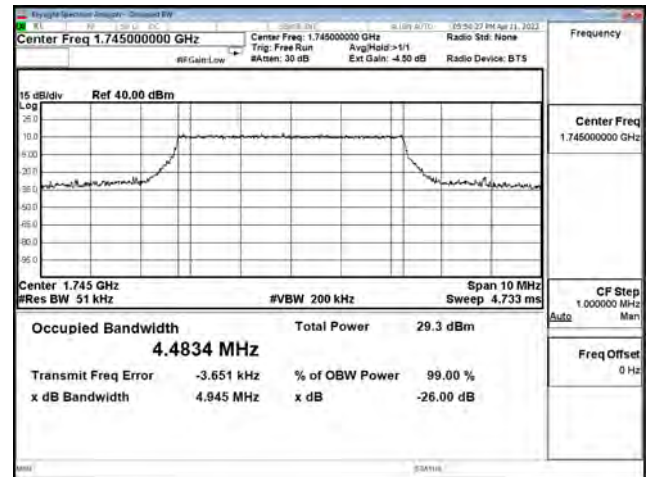

64-QAM_CH132647_5M_25RB0

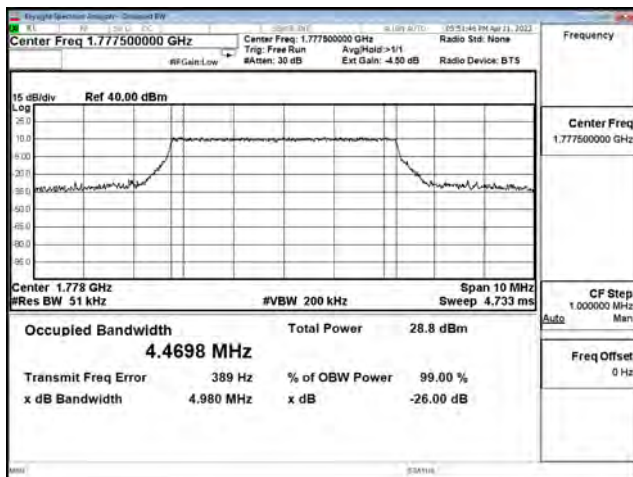

256-QAM_CH131997_5M_25RB0

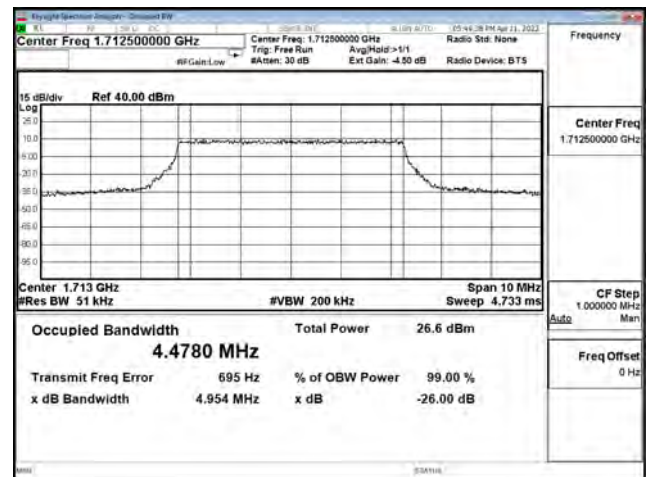

256-QAM_CH132322_5M_25RB0

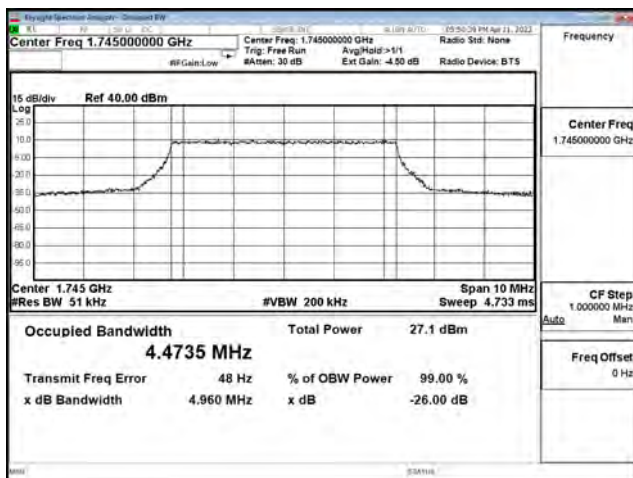

256-QAM_CH132647_5M_25RB0

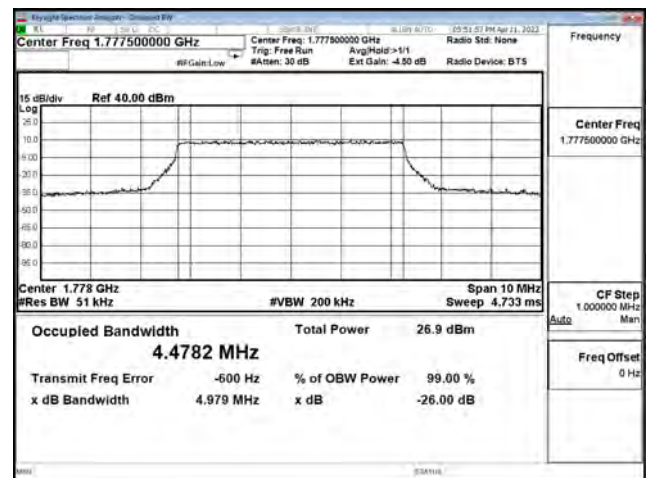

QPSK_CH132022_10M_50RB0

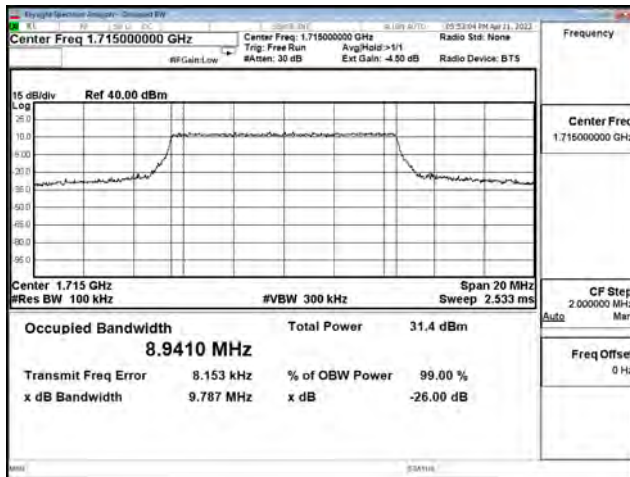

QPSK_CH132322_10M_50RB0

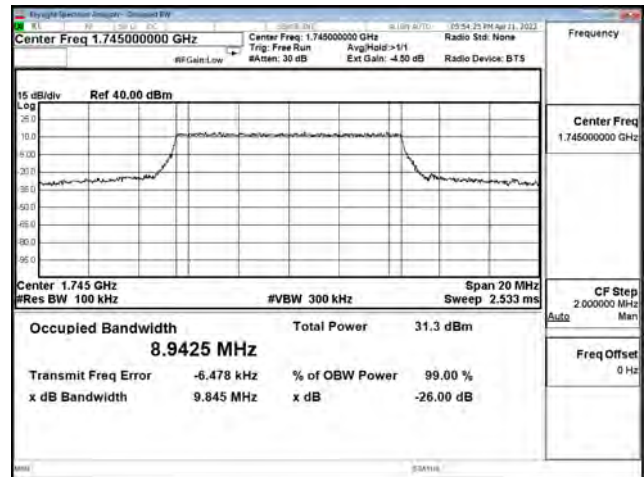

QPSK_CH132622_10M_50RB0

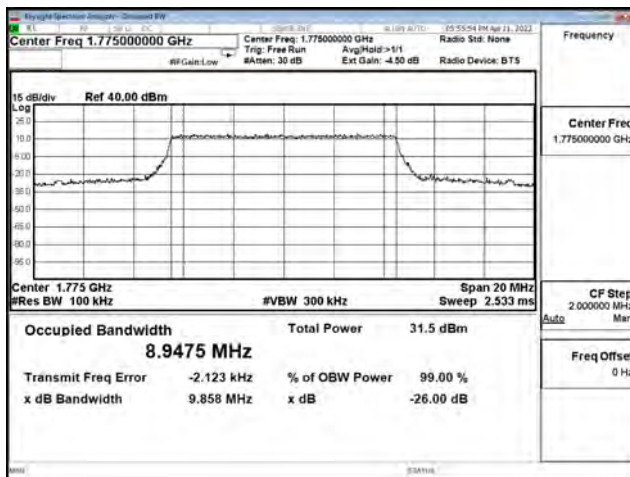

16-QAM_CH132022_10M_50RB0

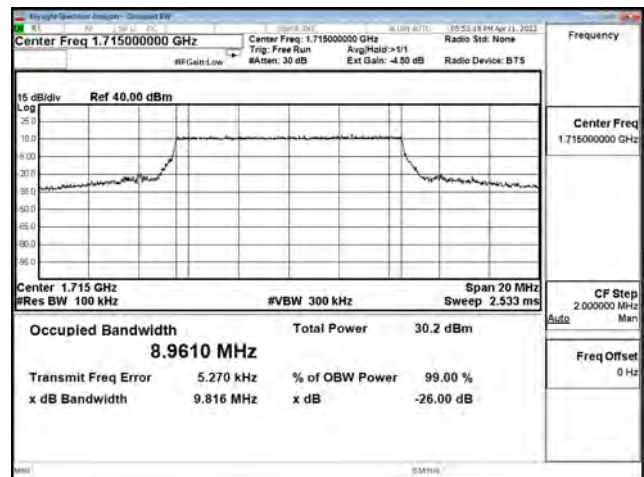

16-QAM_CH132322_10M_50RB0

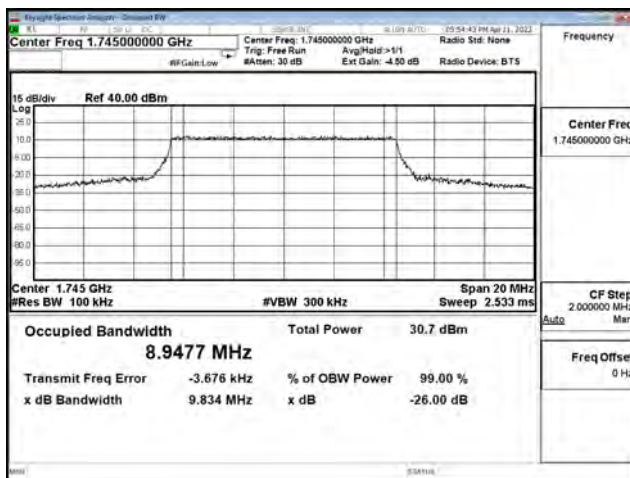

16-QAM_CH132622_10M_50RB0

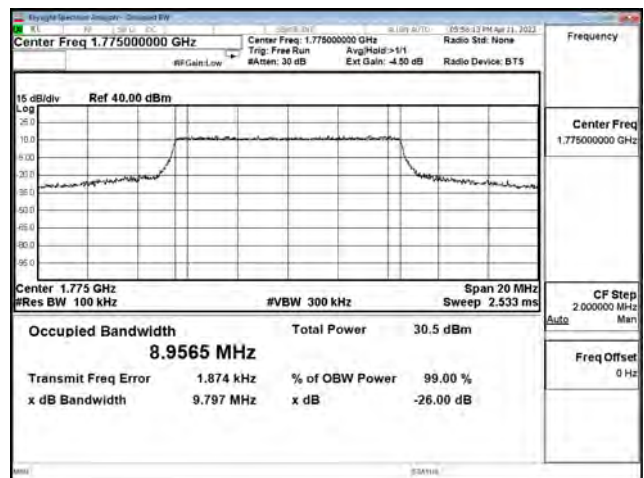

64-QAM_CH132022_10M_50RB0

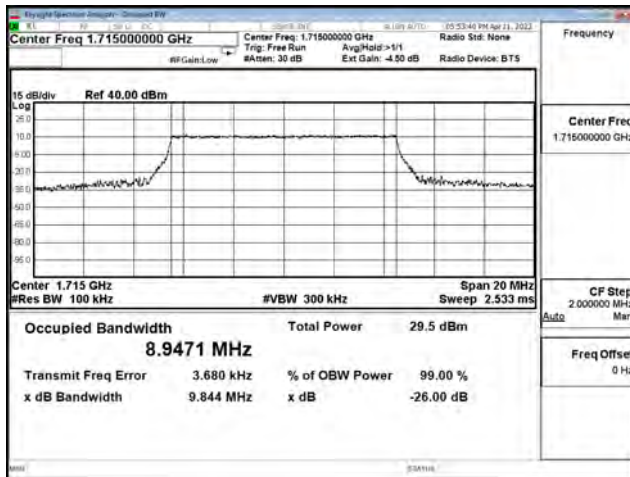

64-QAM_CH132322_10M_50RB0

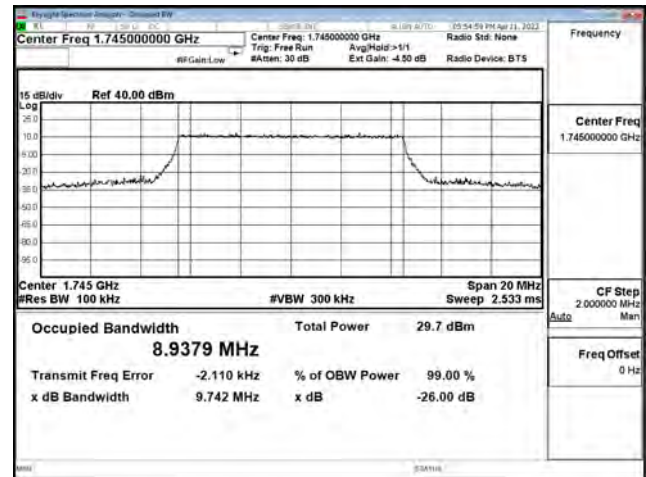

64-QAM_CH132622_10M_50RB0

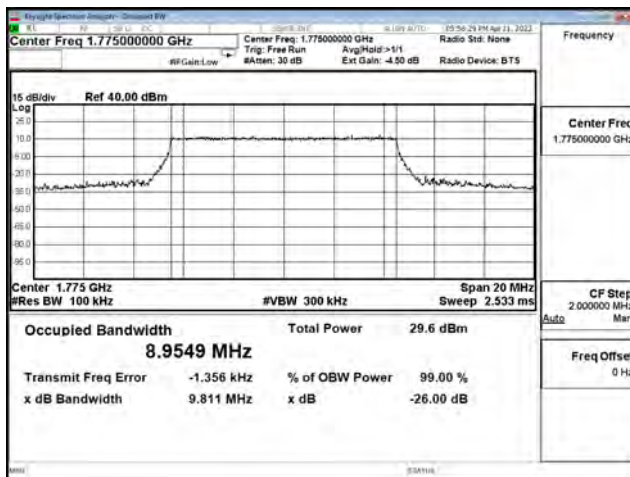

256-QAM_CH132022_10M_50RB0

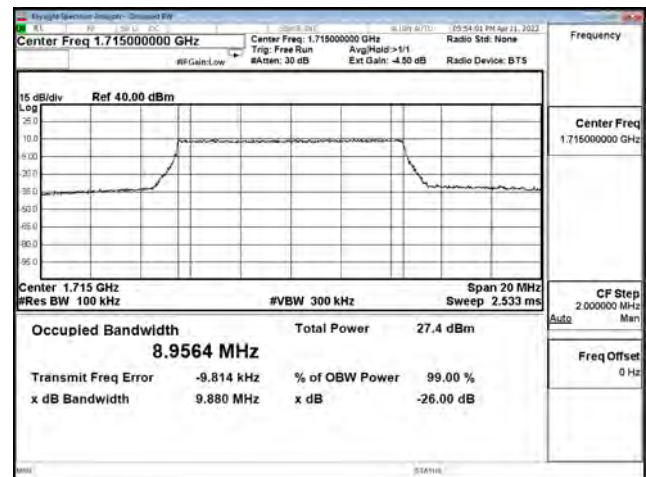

256-QAM_CH132322_10M_50RB0

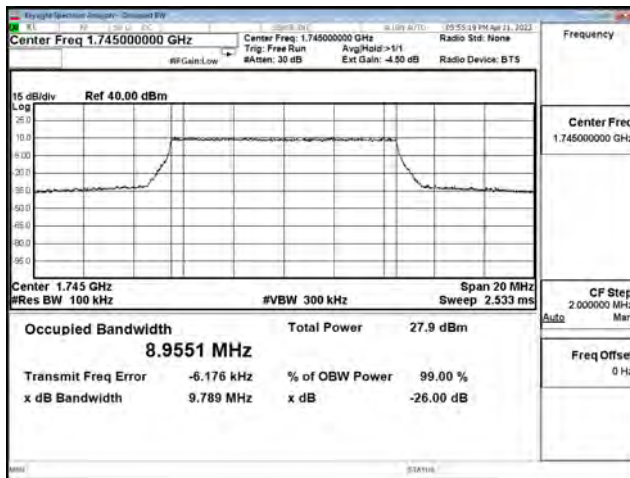

256-QAM_CH132622_10M_50RB0

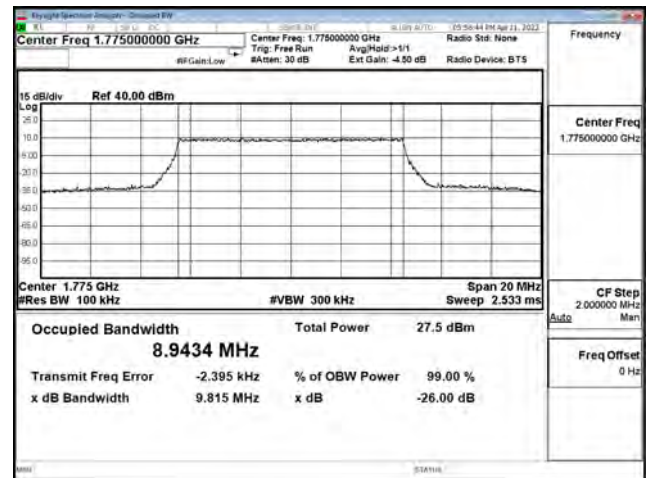

QPSK_CH132047_15M_75RB0

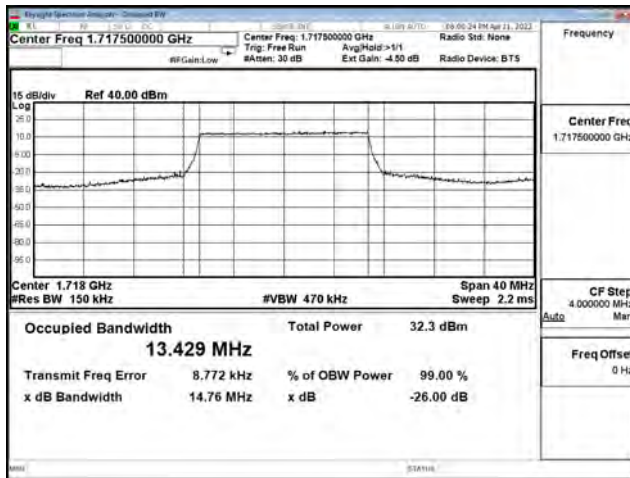

QPSK_CH132322_15M_75RB0

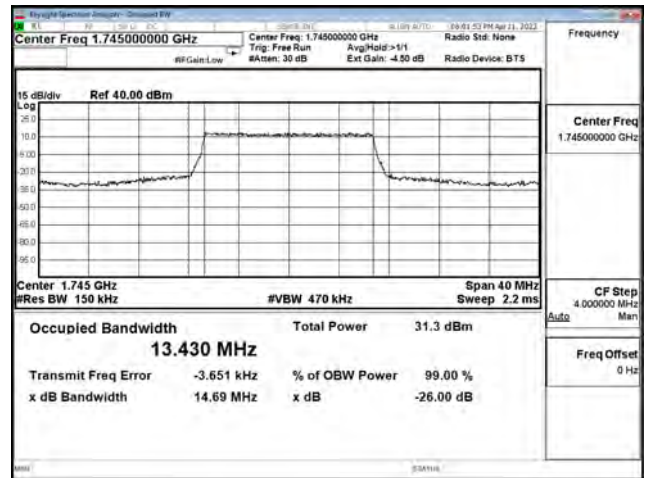

QPSK_CH132597_15M_75RB0

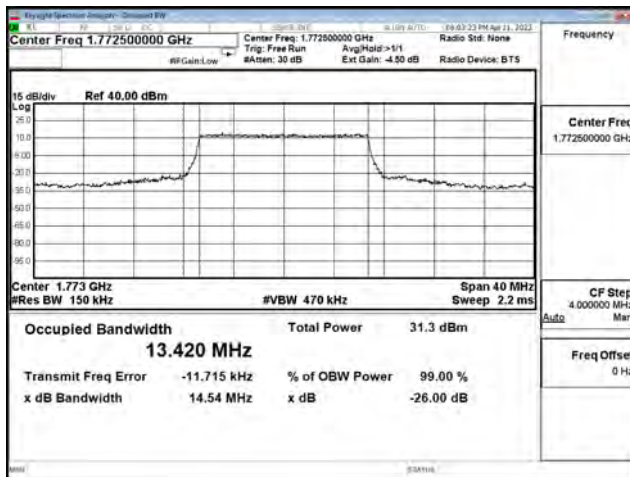

16-QAM_CH132047_15M_75RB0

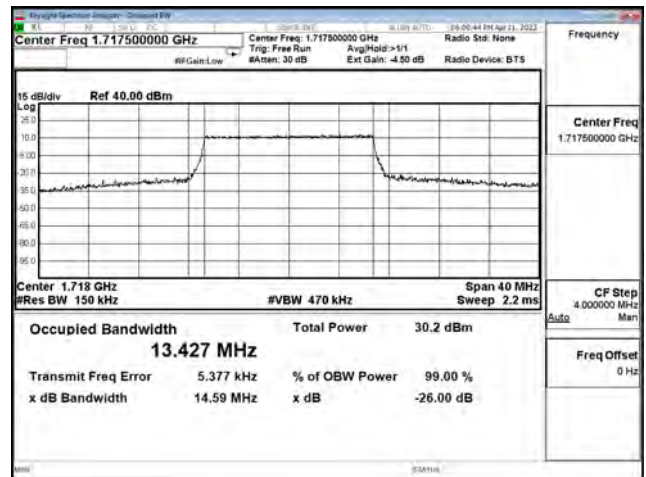

16-QAM_CH132322_15M_75RB0

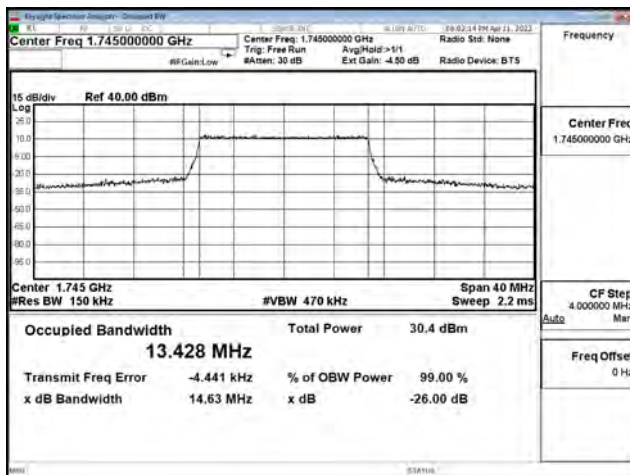

16-QAM_CH132597_15M_75RB0

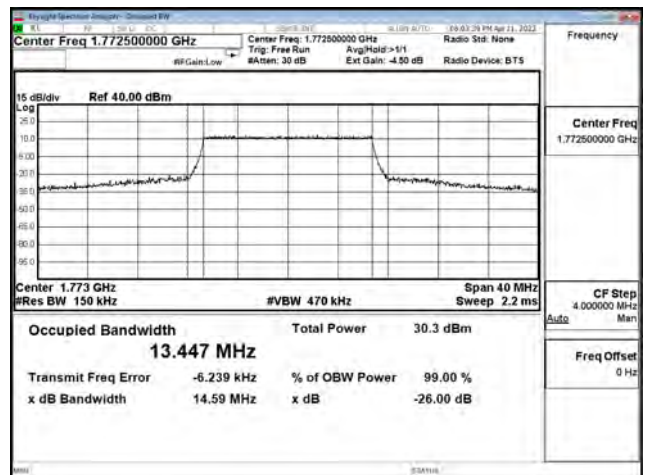

64-QAM_CH132047_15M_75RB0

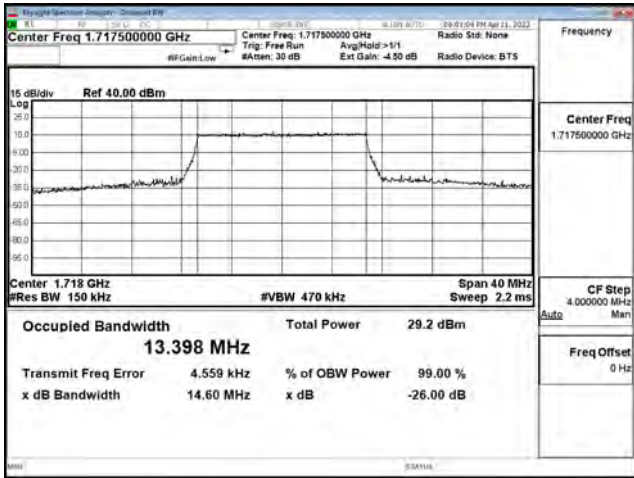

CH132322_15M_64-QAM_75RB0

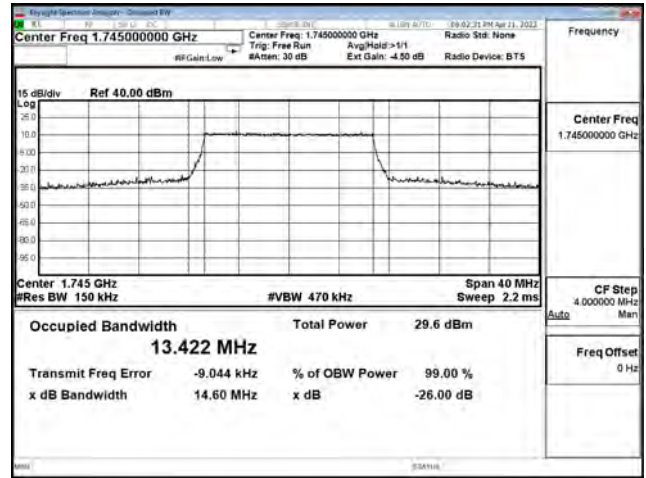

64-QAM_CH132597_15M_75RB0

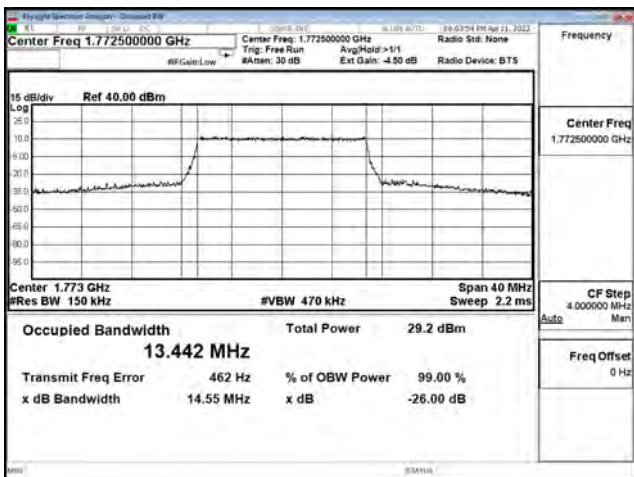

256-QAM_CH132047_15M_75RB0

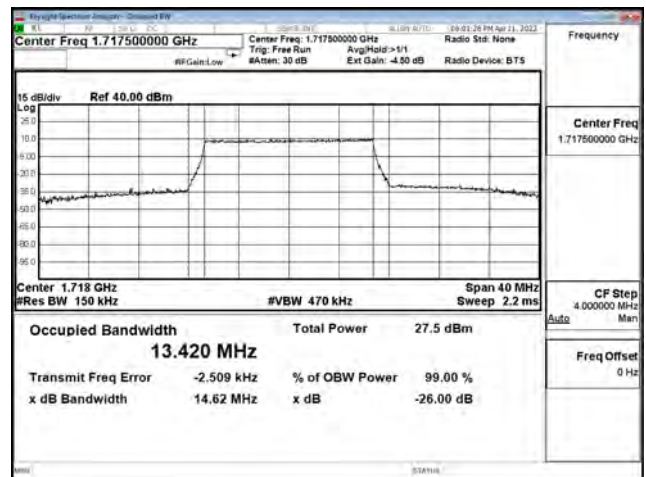

256-QAM_CH132322_15M_75RB0

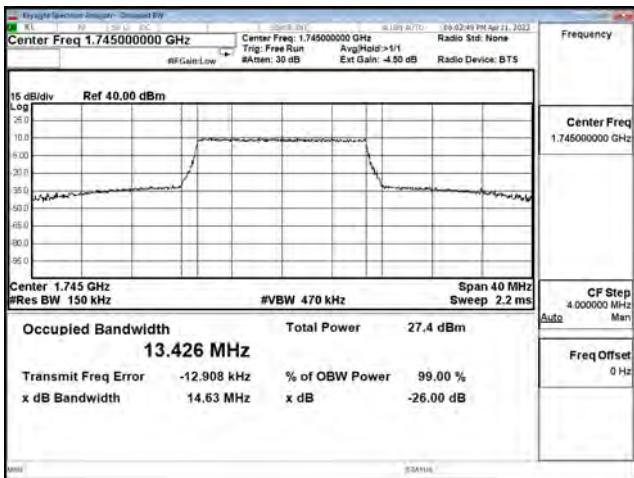

256-QAM_CH132597_15M_75RB0

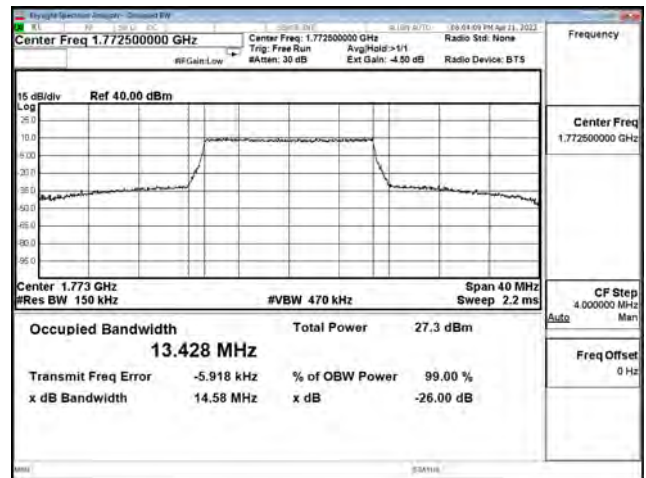

QPSK_CH132072_20M_100RB0

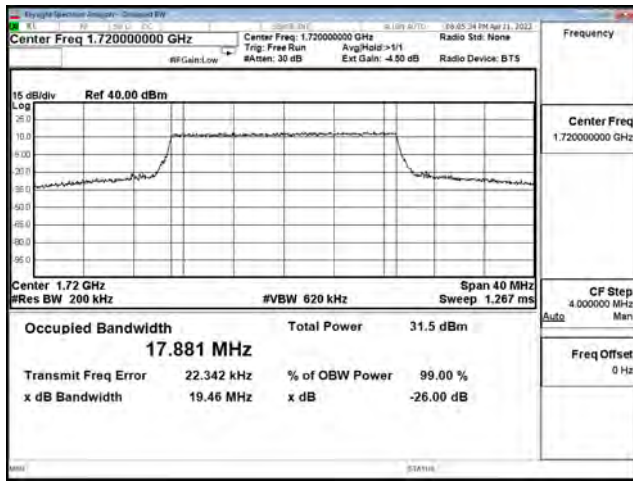

QPSK_CH132322_20M_100RB0

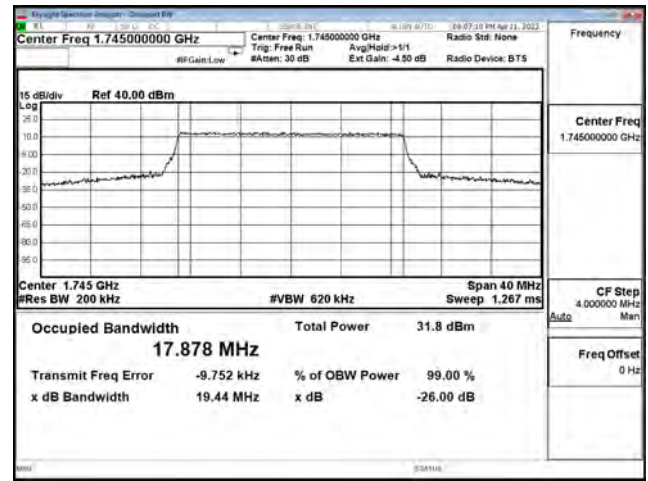

QPSK_CH132572_20M_100RB0

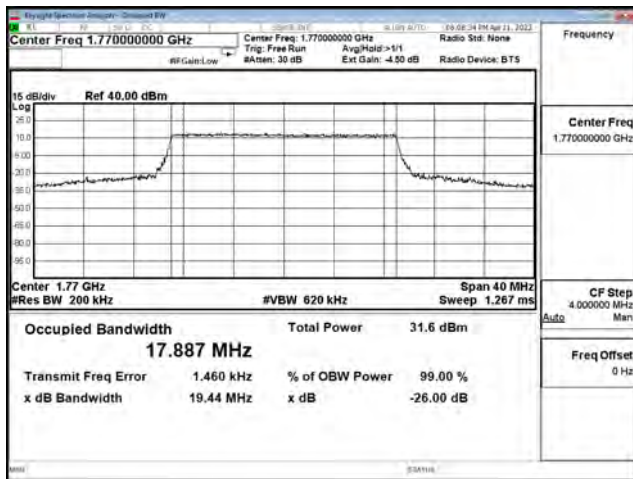

16-QAM_CH132072_20M_100RB0

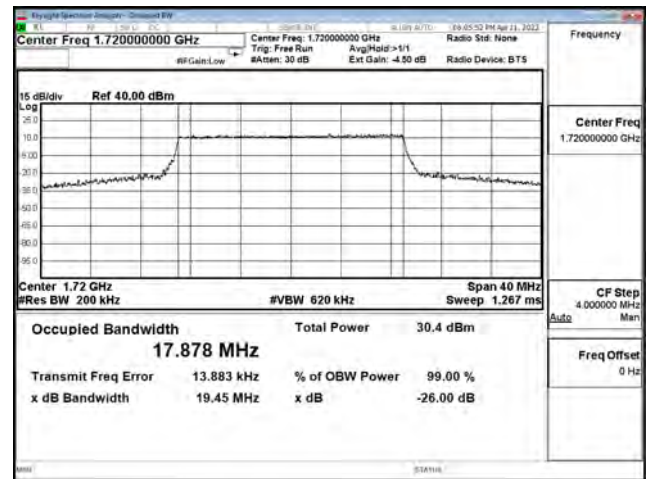

16-QAM_CH132322_20M_100RB0

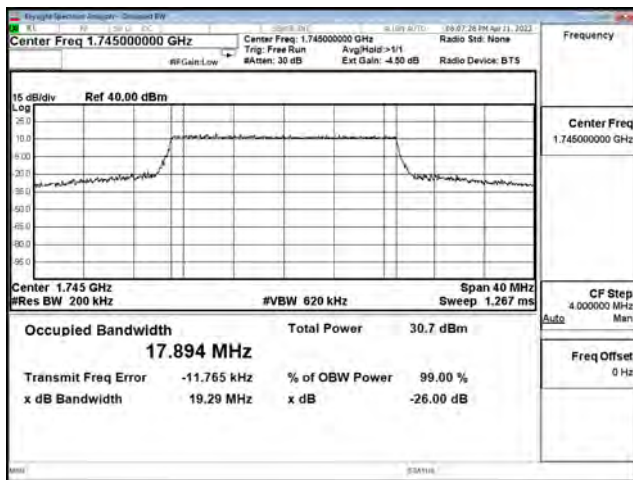

16-QAM_CH132572_20M_100RB0

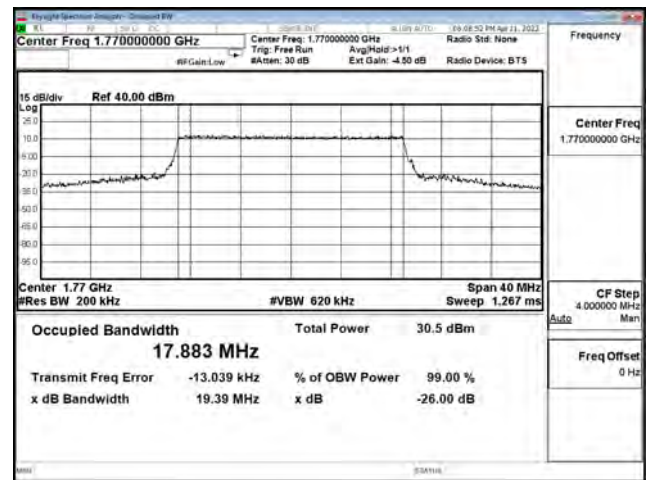

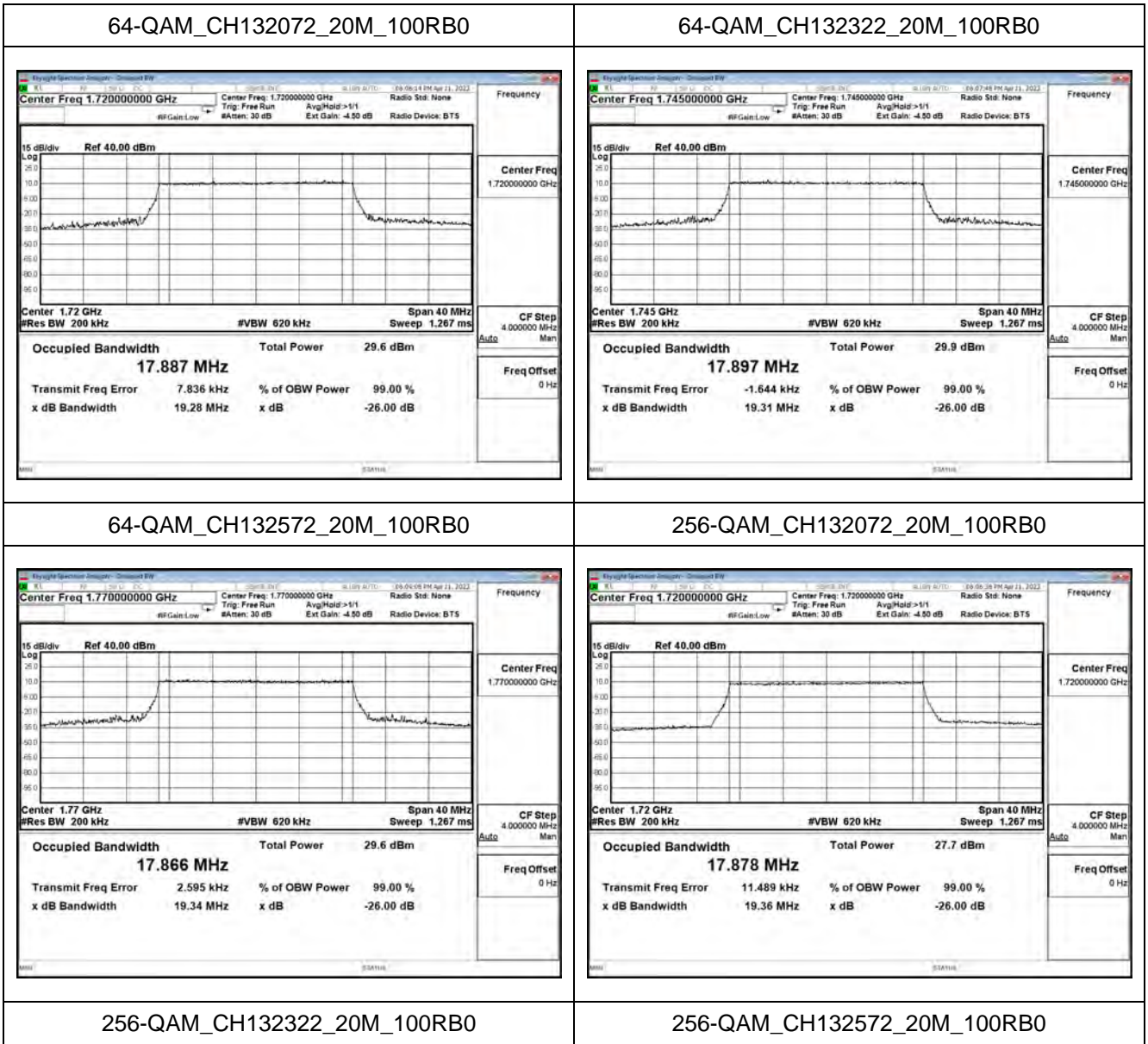

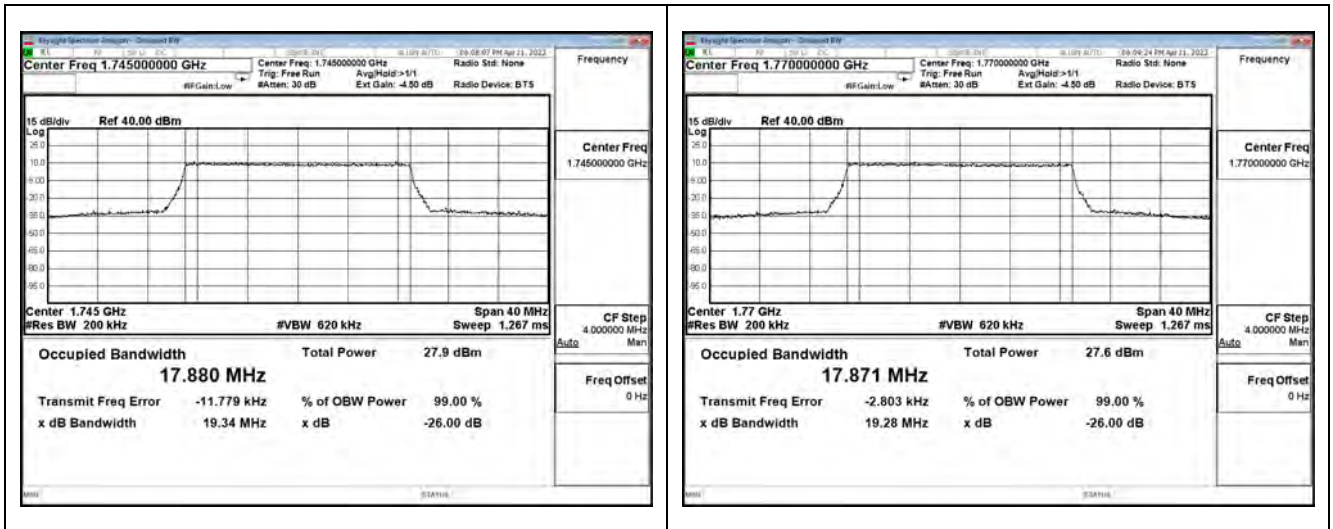

5. Peak to Average Ratio

5.1. Test Setup

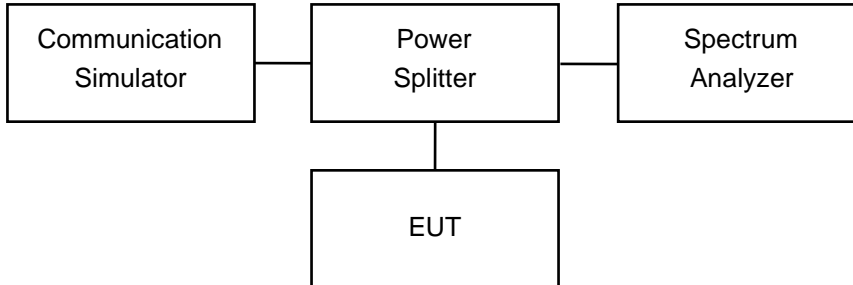

5.2. Test Procedure

1. The EUT makes a call to the communication simulator. The communication simulator station system controlled a EUT to export maximum output power under transmission mode and specific channel frequency. The path loss was compensated to the results for each measurement.
2. Set resolution/measurement bandwidth \geq signal's occupied bandwidth.
3. Set the number of counts to a value that stabilizes the measured CCDF curve.
4. Record the maximum PAPR level associated with a probability of 0.1 %.

5.3. Test Methodology and Reference Procedures

KDB 971168 D01 Power Meas License Digital Systems v03r01

ANSI C63.26-2015

5.4. Test Result of Peak to Average Ratio

Mode 1: LTE Band 2

