

FCC Test Report

Product Name : 5G CPE
Trade Name : WNC
Model No. : FWAR
FCC ID : NKR-LAA2

Applicant : Wistron NeWeb Corporation
Address : 20 Park Avenue II, Hsinchu Science Park, Hsinchu 308, Taiwan

Date of Receipt : Nov. 16, 2020
Issued Date : Dec. 09, 2020
Report No. : 20B0401R-E3042210012
Report Version : V1.0



The test results relate only to the samples tested.
The test report shall not be reproduced except in full without the written approval of DEKRA Testing and Certification Co., Ltd..

Test Report Certification

Issued Date : Dec. 09, 2020

Report No. : 20B0401R-E3042210012



Product Name : 5G CPE

Applicant : Wistron NeWeb Corporation

Address : 20 Park Avenue II, Hsinchu Science Park, Hsinchu 308, Taiwan

Manufacturer : Wistron NeWeb Corporation

Address : 20 Park Avenue II, Hsinchu Science Park, Hsinchu 308, Taiwan

Trade Name : WNC

Model No. : FWAR

FCC ID : NKR-LAA2

EUT Adapter Rated Voltage : AC 100-240V / 50-60Hz

EUT Adapter Test Voltage : AC 120V / 60Hz

Applicable Standard : FCC CFR Title 47 Part 22 Subpart H
FCC CFR Title 47 Part 24 Subpart E
FCC CFR Title 47 Part 27 Subpart L, Subpart F

Test Lab : Hsin Chu Laboratory

Address : No.372-2, Sec. 4, Zhongxing Rd., Zhudong Township, Hsinchu County 310, Taiwan, R.O.C.
TEL: +886-3-582-8001 / FAX: +886-3-582-8958

Test Result : Complied

Documented By : 
 (Carol Tsai / Senior Engineering Adm. Specialist)

Tested By : 
 (Max Chang / Senior Engineer)

Approved By : 
 (Louis Hsu / Deputy Manager)

Revision History

Version	Description	Issued Date
V1.0	Initial issue of report	Dec. 09, 2020

TABLE OF CONTENTS

Description	Page
1. General Information	6
1.1. EUT Description	6
1.2. Mode of Operation	8
1.3. Tested System Details	9
1.4. Configuration of Tested System	9
1.5. Operation Descriptions	9
1.6. Comments and Remarks	10
2. Technical Test	11
2.1. Summary of Test Result	11
2.2. List of Test Equipment	16
2.3. Measurement Uncertainty	19
2.4. Test Environment	20
3. RF Output Power	21
3.1. Test Setup	21
3.2. Test Procedure	21
3.3. Test Method	21
3.4. Test Result of Maximum Power Output	22
3.5. Maximum Conducted Power and ERP/EIRP Power	31
4. Occupied Bandwidth	34
4.1. Test Setup	34
4.2. Test Procedure	34
4.3. Test Method	34
4.4. Test Result	35
5. Peak To Average Ratio	70
5.1. Test Setup	70
5.2. Test Procedure	70
5.3. Test Method	70
5.4. Test Result	71
6. Spurious Emissions	90
6.1. Test Setup	90
6.2. Test Procedure	91
6.3. Test Method	91
6.4. Test Result	92
7. Spurious Emissions at Antenna Terminals	115
7.1. Test Setup	115

7.2. Test Procedure	115
7.3. Test Method	115
7.4. Test Result	116
8. Frequency Stability	128
8.1. Test Setup	128
8.2. Test Procedure	129
8.3. Test Method	129
8.4. Test Result	130
Attachment 1: EUT Test Photographs	

1. General Information

1.1. EUT Description

Product Name	5G CPE
Model No.	FWAR
Trade Name	WNC
FCC ID	NKR-LAA2
TX Frequency (MHz)	LTE Band 2/ NR ENDC n2: 1850~1910
	LTE Band 4: 1710~1755
	LTE Band 5/ NR ENDC n5: 824 ~849
	LTE Band 12: 699~716
	LTE Band 14: 788~798
	LTE Band 66/ NR ENDC n66:1710MHz~1780
Rx Frequency (MHz)	LTE Band 2/ NR ENDC n2: 1930~1990
	LTE Band 4: 2110~2155
	LTE Band 5/ NR ENDC n5: 869~894
	LTE Band 12: 729~746
	LTE Band 14: 758~768
	LTE Band 66/ NR ENDC n66: 2110~2200
ENDC list	ENDC_2A-n5, ENDC_2A-n66, ENDC_5A-n2, ENDC_5A-n66, ENDC_12A-n2, ENDC_12A-n66, ENDC_14A-n2, ENDC_14A-n66, ENDC_66A-n5
Bandwidth	LTE Band 2: 1.4MHz/3MHz/5MHz/10MHz/15MHz/20MHz
	LTE Band 4: 1.4MHz/3MHz/5MHz/10MHz/15MHz/20MHz
	LTE Band 5: 1.4MHz/3MHz/5MHz/10MHz
	LTE Band 12: 1.4MHz/3MHz/5MHz/10MHz
	LTE Band 14: 5MHz/10MHz
	LTE Band 66: 1.4MHz/3MHz/5MHz/10MHz/15MHz/20MHz
	NR ENDC n2(SCC 15KHz): 5MHz/10MHz/15MHz/20MHz
	NR ENDC n5(SCC 15KHz): 5MHz/10MHz/15MHz/20MHz
	NR ENDC n66(SCC 15KHz): 5MHz/10MHz/15MHz/20MHz
Modulation	PI/2 BPSK/QPSK/16-QAM/64QAM/256QAM
HW Version	0.3.3
SW Version	0.16.06.1dbg
IMEI No.	355806710006100

Accessories Information	
Power Adapter (1) (White/Black/Gray)	MFR: Delta, M/N: ADP-120VH D Input: AC 100-240V~2.5A, 50-60Hz Output: 20V, 6A Cable Out: Non-Shielded, 3.0m Power Cord: Non-Shielded, 1.8m
Power Adapter (2) (White/Black/Gray)	MFR: Delta, M/N: ADP-65JH HB Input: AC 100-240V~2.5A, 50-60Hz Output: 19V, 3.42A Cable Out: Non-Shielded, 3.0m Power Cord: Non-Shielded, 1.8m
Power Adapter (3) (White/Black/Gray)	MFR: Delta, M/N: ADH-90AR B Input: AC 100-240V~2.0A, 50-60Hz Output: 56V, 1.61A Power Cord: Non-Shielded, 1.8m

Antenna Information					
No	Manufacturer	Model No.	Part No	Antenna Type	Peak Gain
1	WNC	95XKAC15. GDSVZ	LTE1(ANT_1)	MonoPole Antenna	1.76dBi for Band 2/ n2 3.28dBi for Band 4/ 66/ n66 -1.49dBi for Band 5/ n5 1.56dBi for Band 12 -0.69dBi for Band 14
2	WNC	95XKAC15. GDSVZ	LTE2(ANT_3)	MonoPole Antenna (RX functions)	1.57dBi for Band 2/ n2 2.32dBi for Band 4/ 66/ n66
3	WNC	95XKAC15. GDTVZ	LTE3(ANT_4)	MonoPole Antenna (RX functions)	2.25dBi for Band 2/ n2 2.5dBi for Band 4/ 66/ n66
4	WNC	95XKAC15. GDRVZ	LTE4(ANT_2)	MonoPole Antenna	2.22dBi for Band 2/ n2 2.15dBi for Band 4/ 66/ n66 0.63dBi for Band 5/ n5 -0.87dBi for Band 12 -1.12dBi for Band 14

Note:

This report is prepared for Class II permissive change. The difference compared with original report no.: 2050962R-E3042110012-A is housing and software. The software changes as following:

- 1) Add LTE band 4, band 12, band 14, band 29 and close band 13 by software.
- 2) Close 5G FR2 band n261 by software.

According to above conditions, LTE band 12/ 14 and added EN-DC combination testing and Radiated Spurious Emissions (RSE) worst-case need to be performed and all data were verified to meet the requirements, and other test data refer to original report.

All RSE of EN-DC combination modes have been investigated and recorded worst-case in this report.

1.2. Mode of Operation

The EUT provide all functions described as above. The EUT is tested with maximum rated TX power via the Base Station simulator.

DEKRA has verified the construction and function in typical operation. All the test modes were carried out with the EUT in normal operation, which was shown in this test report and defined as:

Test Mode
Mode 1: ENDC 12A_n2
Mode 2: ENDC 14A_n66
Mode 3: ENDC 2A_n66
Mode 4: ENDC 5A_n2
Mode 5: ENDC 66A_n5

Note:

1. WWAN module ANT_1 support TX/RX functions and support 2UL CA PCC functions.
2. WWAN module ANT_3 and ANT_4 support RX functions.
3. WWAN module ANT_2 2UL CA SCC functions and RX functions.
4. The adapter mode and the PoE mode pre-scanning radiation has determined by the adapter mode is the worst case.
5. This report is prepared for Class II permissive change. The difference compared with original report no.: 2050962R-E3042110012-A is housing and software. The software changes as following:
 - 1) Add LTE band 4, band 12, band 14, band 29 and close band 13 by software.
 - 2) Close 5G FR2 band n261 by software.

According to above conditions, LTE band 12/ 14 and added EN-DC combination testing and Radiated Spurious Emissions (RSE) worst-case need to be performed and all data were verified to meet the requirements, and other test data refer to original report.

All RSE of EN-DC combination modes have been investigated and recorded worst-case in this report.

1.3. Tested System Details

The types for all equipment, plus descriptions of all cables used in the tested system (including inserted cards) are:

Product	Manufacturer	Model No.	Serial No.	FCC ID	Power Cord
1 Base Station	R&S	CMW500	106071	DoC	Non- Shielded, 2m
2 Horn Antenna	Schwarzbeck	BBHA 9120D	1640	DoC	--

1.4. Configuration of Tested System

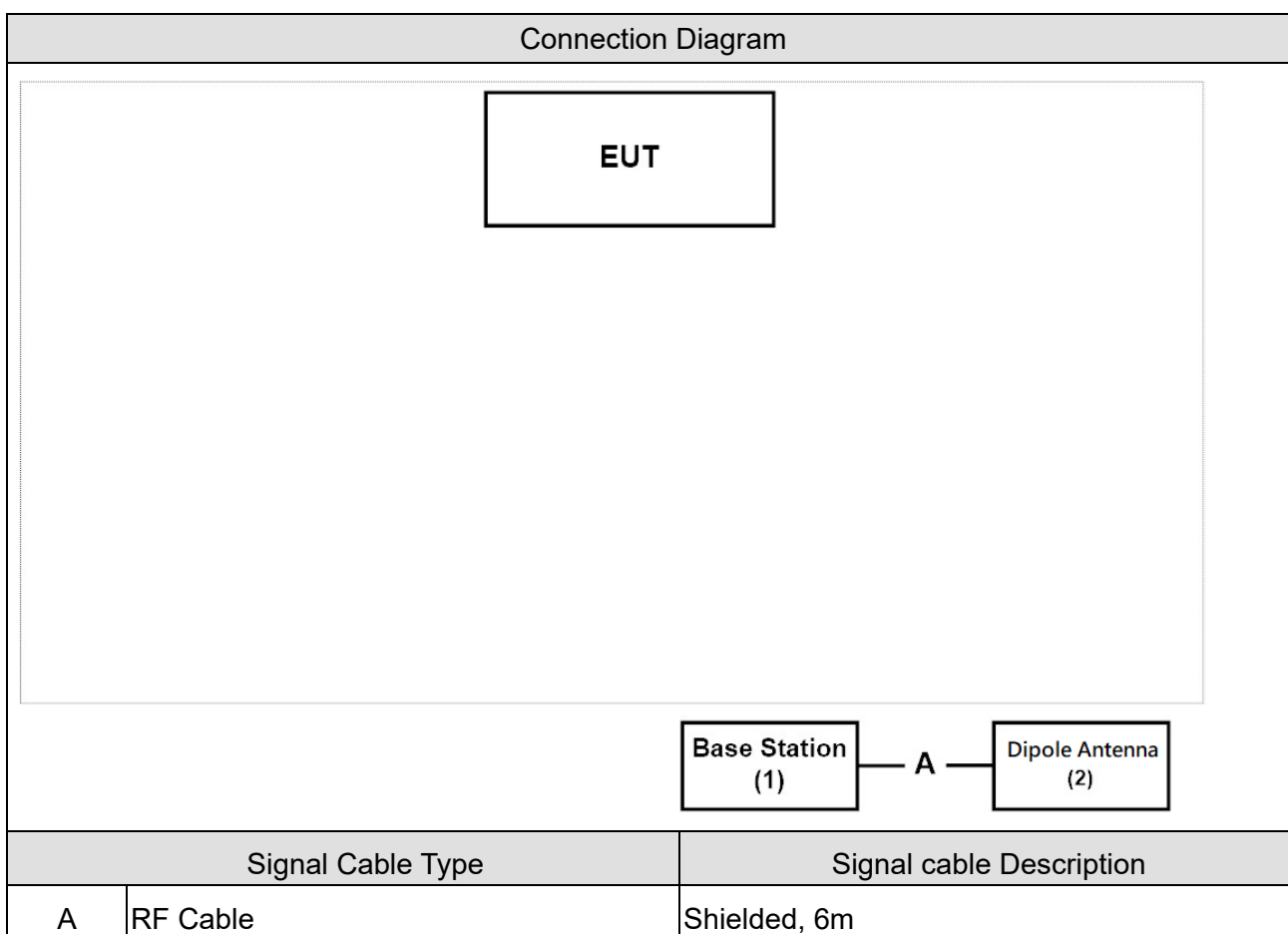

1.5. Operation Descriptions

1	Setup the EUT and simulators as shown on 1.4.
2	Turn on the power of all equipment.
3	The EUT will connect with the Base Station.
4	Repeat the above procedure.

1.6. Comments and Remarks

The product specification and testing instructions for the EUT declared in the report are provided by the manufacturer who will take all responsibilities for the accuracy.

2. Technical Test

2.1. Summary of Test Result

- No deviations from the test standards
- Deviations from the test standards as below description:

Band 2/ n2

Uplink: 1850-1910MHz

Downlink: 1930-1990MHz

Band 2/ n2			
FCC Part 24 Subpart E			
Test item	FCC Reference section	FCC Limit	Result
RF Output Power	§2.1033 §2.1046 §24.232	<2 Watts	Note
Occupied Bandwidth	§2.1049	N/A	Note
Peak-to-average power ratio	§24.232	<13 dB	Note
Spurious Emissions	§2.1053 §24.238	<-13dBm	Pass
Spurious Emissions at Antenna Terminals	§27.238	<-13dBm	Note
Frequency Stability	§2.1055 §24.235	<±2.5 ppm	Note

Note:

This report is prepared for Class II permissive change. The difference compared with original report no.: 2050962R-E3042110012-A is housing and software. The software changes as following:

- 1) Add LTE band 4, band 12, band 14, band 29 and close band 13 by software.
- 2) Close 5G FR2 band n261 by software.

According to above conditions, LTE band 12/ 14 and added EN-DC combination testing and Radiated Spurious Emissions (RSE) worst-case need to be performed and all data were verified to meet the requirements, and other test data refer to original report.

Determining compliance shall be based on the results of the compliance measurement, not taking into account measurement instrumentation uncertainty.

All RSE of EN-DC combination modes have been investigated and recorded worst-case in this report.

Band 4/ 66/ n66

Uplink: 1710~1780MHz

Downlink: 2110~2200MHz

Band 4/ 66/ n66			
FCC Part 27 Subpart L			
Test item	FCC Reference section	FCC Limit	Result
RF Output Power	§2.1033 §2.1046 §27.50	<1 Watts	Note
Occupied Bandwidth	§2.1049	N/A	Note
Peak-to-average power ratio	§27.50	<13 dB	Note
Spurious Emissions	§2.1053 §27.53	<-13dBm	Pass
Spurious Emissions at Antenna Terminals	§27.53	<-13dBm	Note
Frequency Stability	§2.1055 §27.54	<2.5 ppm	Note

Note:

This report is prepared for Class II permissive change. The difference compared with original report no.: 2050962R-E3042110012-A is housing and software. The software changes as following:

- 1) Add LTE band 4, band 12, band 14, band 29 and close band 13 by software.
- 2) Close 5G FR2 band n261 by software.

According to above conditions, LTE band 12/ 14 and added EN-DC combination testing and Radiated Spurious Emissions (RSE) worst-case need to be performed and all data were verified to meet the requirements, and other test data refer to original report.

Determining compliance shall be based on the results of the compliance measurement, not taking into account measurement instrumentation uncertainty.

All RSE of EN-DC combination modes have been investigated and recorded worst-case in this report.

Band 5 / n5

Uplink: 824-849MHz

Downlink: 869-894MHz

Band 5 / n5			
FCC Part 22 Subpart H			
Test item	FCC Reference section	FCC Limit	Result
RF Output Power	§2.1033 §2.1046 §22.913	<7 Watts	Note
Occupied Bandwidth	§2.1049	N/A	Note
Peak-to-average power ratio	§22.913	<13 dB	Note
Spurious Emissions	§2.1053 §22.917	<-13dBm	Pass
Spurious Emissions at Antenna Terminals	§22.917	<-13dBm	Note
Frequency Stability	§2.1055 §22.335	<±2.5 ppm	Note

Note:

This report is prepared for Class II permissive change. The difference compared with original report no.: 2050962R-E3042110012-A is housing and software. The software changes as following:

- 1) Add LTE band 4, band 12, band 14, band 29 and close band 13 by software.
- 2) Close 5G FR2 band n261 by software.

According to above conditions, LTE band 12/ 14 and added EN-DC combination testing and Radiated Spurious Emissions (RSE) worst-case need to be performed and all data were verified to meet the requirements, and other test data refer to original report.

Determining compliance shall be based on the results of the compliance measurement, not taking into account measurement instrumentation uncertainty.

All RSE of EN-DC combination modes have been investigated and recorded worst-case in this report.

B12

Uplink: 699-716MHz

Downlink: 729-746MHz

LTE B12			
FCC Part 27 Subpart F			
Industry Canada RSS-130, issue2, Industry Canada RSS-GEN			
Test item	FCC Reference section	FCC Limit	Result
RF Output Power	§2.1033 §2.1046 §27.50	<3 Watts ERP	Pass
Occupied Bandwidth	§2.1049	N/A	Pass
Peak-to-average power ratio	§27.50	<13 dB	Pass
Spurious Emissions	§2.1053 §27.53	<-13dBm	Pass
Spurious Emissions at Antenna Terminals	§27.53	<-13dBm	Pass
Frequency Stability	§2.1055 §27.54	<±2.5 ppm	Pass

Determining compliance shall be based on the results of the compliance measurement, not taking into account measurement instrumentation uncertainty.

B14

Uplink: 788-798MHz

Downlink: 758-768MHz

LTE B14			
FCC Part 90 Subpart R			
Industry Canada RSS-140, issue1, Industry Canada RSS-GEN			
Test item	FCC Reference section	FCC Limit	Result
RF Output Power	§2.1033 §2.1046 §90.542	<3 Watts ERP	Pass
Occupied Bandwidth	§2.1049	N/A	Pass
Peak-to-average power ratio	§27.50	<13 dB	Pass
Spurious Emissions	§2.1053 §90.543	<-13dBm	Pass
Spurious Emissions at Antenna Terminals	§90.543	<-35dBm	Pass
Frequency Stability	§2.1055 §90.543	<±2.5 ppm	Pass

Determining compliance shall be based on the results of the compliance measurement, not taking into account measurement instrumentation uncertainty.

2.2. List of Test Equipment

RF Output Power / SR12-H

Instrument	Manufacturer	Model No.	Serial No.	Cal. Date	Next Cal. Date
Signal & Spectrum Analyzer	R&S	FSV40	101049	2020/03/30	2021/03/29
EXA Signal Analyzer	Keysight	N9010A	MY51440132	2020/02/21	2021/02/20
Spectrum Analyzer	Keysight	N9030B	MY57140404	2020/06/03	2021/06/02
Spectrum Analyzer	Keysight	N9010B	MY57110159	2020/04/15	2021/04/14
Wireless Conn. Tseter	R&S	CMW500	157118	2020/07/23	2021/07/22
Wideband Radio Communication Tester	R&S	CMW500	106071	2020/02/03	2021/02/02

Occupied Bandwidth / SR12-H

Instrument	Manufacturer	Model No.	Serial No.	Cal. Date	Next Cal. Date
Signal & Spectrum Analyzer	R&S	FSV40	101049	2020/03/30	2021/03/29
EXA Signal Analyzer	Keysight	N9010A	MY51440132	2020/02/21	2021/02/20
Spectrum Analyzer	Keysight	N9030B	MY57140404	2020/06/03	2021/06/02
Spectrum Analyzer	Keysight	N9010B	MY57110159	2020/04/15	2021/04/14
Wireless Conn. Tseter	R&S	CMW500	157118	2020/07/23	2021/07/22
Wideband Radio Communication Tester	R&S	CMW500	106071	2020/02/03	2021/02/02

Peak To Average Ratio / SR12-H

Instrument	Manufacturer	Model No.	Serial No.	Cal. Date	Next Cal. Date
Signal & Spectrum Analyzer	R&S	FSV40	101049	2020/03/30	2021/03/29
EXA Signal Analyzer	Keysight	N9010A	MY51440132	2020/02/21	2021/02/20
Spectrum Analyzer	Keysight	N9030B	MY57140404	2020/06/03	2021/06/02
Spectrum Analyzer	Keysight	N9010B	MY57110159	2020/04/15	2021/04/14
Wireless Conn. Tseter	R&S	CMW500	157118	2020/07/23	2021/07/22
Wideband Radio Communication Tester	R&S	CMW500	106071	2020/02/03	2021/02/02

Conducted Band Edge Emissions / SR12-H

Instrument	Manufacturer	Model No.	Serial No.	Cal. Date	Next Cal. Date
Signal & Spectrum Analyzer	R&S	FSV40	101049	2020/03/30	2021/03/29
EXA Signal Analyzer	Keysight	N9010A	MY51440132	2020/02/21	2021/02/20
Spectrum Analyzer	Keysight	N9030B	MY57140404	2020/06/03	2021/06/02
Spectrum Analyzer	Keysight	N9010B	MY57110159	2020/04/15	2021/04/14
Wireless Conn. Tseter	R&S	CMW500	157118	2020/07/23	2021/07/22
Wideband Radio Communication Tester	R&S	CMW500	106071	2020/02/03	2021/02/02

Spurious Emission / CB2-H

Instrument	Manufacturer	Model No.	Serial No.	Cal. Date	Next Cal. Date
Horn Antenna	Schwarzbeck	BBHA 9120D	639	2020/06/04	2021/06/03
Bilog Antenna	Teseq	CBL6112D	23191	2020/06/12	2021/06/11
Signal & Spectrum Analyzer	R&S	FSV40	101049	2020/03/30	2021/03/29
EXA Signal Analyzer	Keysight	N9010A	MY51440132	2020/02/21	2021/02/20
Signal Analyzer	R&S	FSVA40	101455	2020/10/12	2021/10/11
Horn Antenna	Schwarzbeck	BBHA 9170	202	2019/12/27	2020/12/26
Pre-Amplifier	DEKRA	AP-400C	201801231	2019/12/03	2020/12/02
Pre-Amplifier	EMCI	EMC11830I	980366	2020/11/30	2021/11/29
Horn Antenna	Schwarzbeck	BBHA 9120D	01656	2020/10/14	2021/10/13
Pre-Amplifier	DEKRA	AP-025C	12183122	2020/09/03	2021/09/02
Signal Analyzer	R&S	FSV40	101435	2020/06/24	2021/06/23
Wideband Radio Communication Tester	R&S	CMW500	106071	2020/02/03	2021/02/02
Wireless Conn. Tseter	R&S	CMW500	157118	2020/07/23	2021/07/22
Coaxial Cable(13m)	Huber+Suhner	SF104	CB2-H	2020/07/25	2021/07/24
DEKRA Testing System	DEKRA	Version 1.2	CB2-H	NA	NA

Spurious Emissions at Antenna Terminals / SR12-H

Instrument	Manufacturer	Model No.	Serial No.	Cal. Date	Next Cal. Date
Signal & Spectrum Analyzer	R&S	FSV40	101049	2020/03/30	2021/03/29
EXA Signal Analyzer	Keysight	N9010A	MY51440132	2020/02/21	2021/02/20
Spectrum Analyzer	Keysight	N9030B	MY57140404	2020/06/03	2021/06/02
Spectrum Analyzer	Keysight	N9010B	MY57110159	2020/04/15	2021/04/14
Wireless Conn. Tseter	R&S	CMW500	157118	2020/07/23	2021/07/22
Wideband Radio Communication Tester	R&S	CMW500	106071	2020/02/03	2021/02/02

Frequency Stability Under Temperature & Voltage Variations / SR12-H

Instrument	Manufacturer	Model No.	Serial No.	Cal. Date	Next Cal. Date
Signal & Spectrum Analyzer	R&S	FSV40	101049	2020/03/30	2021/03/29
EXA Signal Analyzer	Keysight	N9010A	MY51440132	2020/02/21	2021/02/20
Spectrum Analyzer	Keysight	N9030B	MY57140404	2020/06/03	2021/06/02
Spectrum Analyzer	Keysight	N9010B	MY57110159	2020/04/15	2021/04/14
Wireless Conn. Tseter	R&S	CMW500	157118	2020/07/23	2021/07/22
Wideband Radio Communication Tester	R&S	CMW500	106071	2020/02/03	2021/02/02

Note: All equipment upon which need to calibrated are with calibration period of 1 year.

2.3. Measurement Uncertainty

Test Item	Uncertainty
RF Output Power	± 1.27 dB
Occupied Bandwidth	± 10 Hz
Peak To Average Ratio	Not exceed 13 dB
Spurious Emissions	± 1.27 dB for Conducted Measurement ± 3.2 dB for Radiated Measurement
Spurious Emissions at Antenna Terminals	± 3.2 dB
Frequency Stability	± 10 Hz

2.4. Test Environment

Items	Test Item	Required	Test Site
Temperature (°C)	RF Output Power	15 - 35	1
Humidity (%RH)		20 - 75	
Temperature (°C)	Occupied Bandwidth	15 - 35	1
Humidity (%RH)		20 - 75	
Temperature (°C)	Peak To Average Ratio	15 - 35	1
Humidity (%RH)		20 - 75	
Temperature (°C)	Spurious Emission	15 - 35	1
Humidity (%RH)		20 - 75	
Temperature (°C)	Spurious Emissions at Antenna Terminals	15 - 35	1
Humidity (%RH)		20 - 75	
Temperature (°C)	Frequency Stability	15 - 35	1
Humidity (%RH)		20 - 75	

Note: Test site information refers to Laboratory Information.

USA : FCC Registration Number: TW3024

Canada CAB identifier : TW3024

The address and introduction of DEKRA Testing and Certification Co., Ltd. laboratories can be founded in our Web site: <http://www.dekra.com.tw>

If you have any comments, please don't hesitate to contact us. Our test sites as below:

Test Laboratory	DEKRA Testing and Certification Co., Ltd.
Address	1. No.372, Sec. 4, Zhongxing Rd., Zhudong Township, Hsinchu County 31061, Taiwan, R.O.C. 2. No.372-2, Sec. 4, Zhongxing Rd., Zhudong Township, Hsinchu County 31061, Taiwan, R.O.C.
Phone number	1. +886-3-582-8001 2. +886-3-582-8001
Fax number	1. +886-3-582-8958 2. +886-3-582-8958
Email address	info.tw@dekra.com
Website	http://www.dekra.com.tw

3. RF Output Power

3.1. Test Setup

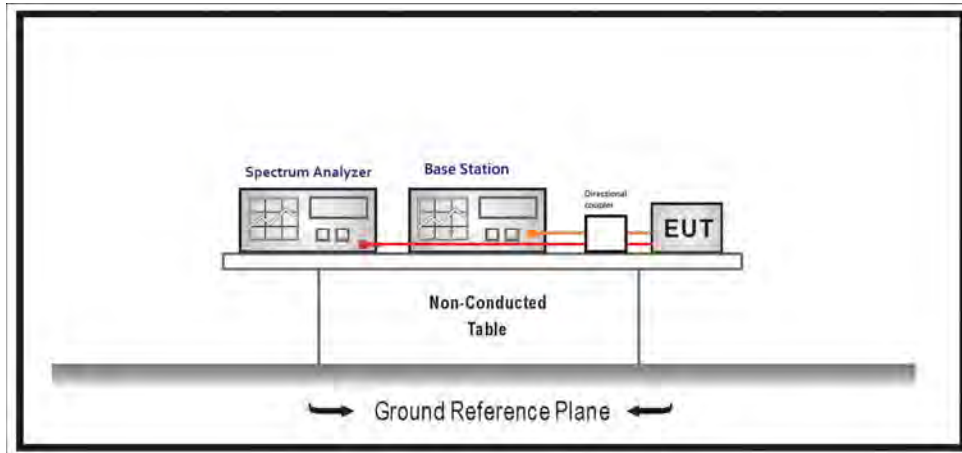

3.2. Test Procedure

- The RF output of the transmitter was connected to base station simulator.
- The RF output of EUT was connected to the power meter by RF cable and attenuator. The path loss was compensated to the results for each measurement..
- Set EUT at maximum average power by base station emulator.
- Measure lowest, middle, and highest channels for each bandwidth and different modulation.

Effective Isotropic Radiated Power = Conducted Power(dBm) + Antenna Gain(dBi)

Effective Radiated Power = Conducted Power(dBm) + Antenna Gain(dBi) - 2.15dB

3.3. Test Method

KDB 971168 D01 Power Meas License Digital Systems v03 sub-clause5.2.4

ANSI C63.26-2015 Sub-clause 5.2.4.2

3.4. Test Result of Maximum Power Output

Product	5G CPE		
Test Item	RF Output Power		
Test Mode	Mode 1: ENDC 12A_n2		
Date of Test	2020/11/25	Test Site	SR12-H
Temperature (°C)	23	Humidity (%RH)	63

Band	Channel Freq. (MHz)	Modulation	RB No.	RB offset	MPR	Conducted Output Power (dBm)
Band 12 1.4MHz	23017 699.7	QPSK	1	0	0	22.13
		QPSK		2		22.09
		QPSK		5		22.03
		QPSK	6	0	1	21.15
		16-QAM	1	0	1	21.01
		16-QAM		2		21.08
		16-QAM		5		20.99
		16-QAM	6	0	2	20.16
	23095 707.5	QPSK	1	0	0	21.97
		QPSK		2		22.05
		QPSK		5		21.99
		QPSK	6	0	1	21.07
		16-QAM	1	0	1	20.98
		16-QAM		2		21.25
		16-QAM		5		21.06
		16-QAM	6	0	2	20.00
	23173 715.3	QPSK	1	0	0	21.98
		QPSK		2		22.01
		QPSK		5		20.97
		QPSK	6	0	1	21.08
		16-QAM	1	0	1	21.20
		16-QAM		2		21.22
		16-QAM		5		21.08
		16-QAM	6	0	2	19.99

Band	Channel Freq. (MHz)	Modulation	RB No.	RB offset	MPR	Conducted Output Power (dBm)
Band 12 3MHz	23025 700.5	QPSK	1	0	0	22.15
		QPSK		7		22.06
		QPSK		14		21.87
		QPSK	15	0	1	21.21
		16-QAM	1	0	1	21.35
		16-QAM		7		21.33
		16-QAM		14		21.16
		16-QAM	15	0	2	20.30
	23095 707.5	QPSK	1	0	0	22.04
		QPSK		7		22.03
		QPSK		14		22.11
		QPSK	15	0	1	21.11
		16-QAM	1	0	1	21.16
		16-QAM		7		21.30
		16-QAM		14		21.10
		16-QAM	15	0	2	20.06
	23165 714.5	QPSK	1	0	0	22.14
		QPSK		7		22.13
		QPSK		14		22.01
		QPSK	15	0	1	21.07
		16-QAM	1	0	1	21.30
		16-QAM		7		21.34
		16-QAM		14		21.11
		16-QAM	15	0	2	20.17

Band	Channel Freq. (MHz)	Modulation	RB No.	RB offset	MPR	Conducted Output Power (dBm)
Band 12 5MHz	23035 701.5	QPSK	1	0	0	22.15
		QPSK		12		22.13
		QPSK		24		22.06
		QPSK	25	0	1	21.24
		16-QAM	1	0	1	21.36
		16-QAM		12		21.34
		16-QAM		24		21.29
		16-QAM	25	0	2	20.35
	23095 707.5	QPSK	1	0	0	22.13
		QPSK		12		22.09
		QPSK		24		22.05
		QPSK	25	0	1	21.18
		16-QAM	1	0	1	21.54
		16-QAM		12		21.60
		16-QAM		24		21.53
		16-QAM	25	0	2	20.12
	23155 713.5	QPSK	1	0	0	22.12
		QPSK		12		22.05
		QPSK		24		22.16
		QPSK	25	0	1	21.23
		16-QAM	1	0	1	21.08
		16-QAM		12		21.17
		16-QAM		24		21.13
		16-QAM	25	0	2	20.30

Band	Channel Freq. (MHz)	Modulation	RB No.	RB offset	MPR	Conducted Output Power (dBm)
Band 12 10MHz	23060 704	QPSK	1	0	0	22.28
		QPSK		24		21.93
		QPSK		49		21.96
		QPSK	50	0	1	21.28
		16-QAM	1	0	1	21.31
		16-QAM		24		21.29
		16-QAM		49		21.27
		16-QAM	50	0	2	20.24
	23095 707.5	QPSK	1	0	0	22.27
		QPSK		24		22.06
		QPSK		49		22.12
		QPSK	50	0	1	21.26
		16-QAM	1	0	1	21.21
		16-QAM		24		21.20
		16-QAM		49		21.17
		16-QAM	50	0	2	20.26
	23130 711	QPSK	1	0	0	22.26
		QPSK		24		22.17
		QPSK		49		21.95
		QPSK	50	0	1	21.22
		16-QAM	1	0	1	21.23
		16-QAM		24		21.31
		16-QAM		49		21.29
		16-QAM	50	0	2	20.26

Band	Channel Freq. (MHz)	Modulation	RB No.	RB offset	MPR	Conducted Output Power (dBm)
Band 12 1.4MHz	23017 699.7	64-QAM	1	0	1	20.89
		64-QAM		2		20.81
		64-QAM		5		20.88
		64-QAM	6	0	2	20.22
	23095 707.5	64-QAM	1	0	1	20.48
		64-QAM		2		20.72
		64-QAM		5		20.57
		64-QAM	6	0	2	20.22
	23173 715.3	64-QAM	1	0	1	20.80
		64-QAM		2		20.53
		64-QAM		5		20.72
		64-QAM	6	0	2	20.40
Band	Channel Freq. (MHz)	Modulation	RB No.	RB offset	MPR	Conducted Output Power (dBm)
Band 12 3MHz	23025 700.5	64-QAM	1	0	1	20.64
		64-QAM		7		20.42
		64-QAM		14		20.50
		64-QAM	15	0	2	20.42
	23095 707.5	64-QAM	1	0	1	20.96
		64-QAM		7		20.51
		64-QAM		14		20.94
		64-QAM	15	0	2	20.13
	23165 714.5	64-QAM	1	0	1	20.88
		64-QAM		7		20.92
		64-QAM		14		20.37
		64-QAM	15	0	2	20.30

Band	Channel Freq. (MHz)	Modulation	RB No.	RB offset	MPR	Conducted Output Power (dBm)
Band 12 5MHz	23035 701.5	64-QAM	1	0	1	20.69
		64-QAM		12		20.63
		64-QAM		24		20.46
		64-QAM	25	0	2	20.08
	23095 707.5	64-QAM	1	0	1	20.53
		64-QAM		12		20.33
		64-QAM		24		20.45
		64-QAM	25	0	2	20.25
	23155 713.5	64-QAM	1	0	1	20.47
		64-QAM		12		20.40
		64-QAM		24		20.59
		64-QAM	25	0	2	20.14
Band	Channel Freq. (MHz)	Modulation	RB No.	RB offset	MPR	Conducted Output Power (dBm)
Band 12 10MHz	23060 704	64-QAM	1	0	1	20.85
		64-QAM		24		20.54
		64-QAM		49		20.81
		64-QAM	50	0	2	20.33
	23095 707.5	64-QAM	1	0	1	20.72
		64-QAM		24		20.34
		64-QAM		49		20.78
		64-QAM	50	0	2	20.15
	23130 711	64-QAM	1	0	1	20.83
		64-QAM		24		20.82
		64-QAM		49		20.70
		64-QAM	50	0	2	20.06

Product	5G CPE		
Test Item	RF Output Power		
Test Mode	Mode 2: ENDC 14A_n66		
Date of Test	2020/11/25	Test Site	SR12-H
Temperature (°C)	23	Humidity (%RH)	63

Band	Channel Freq. (MHz)	Modulation	RB No.	RB offset	MPR	Conducted Output Power (dBm)
Band 14 5MHz	23305 790.5	QPSK	1	0	0	24.01
		QPSK		12		23.73
		QPSK		24		23.95
		QPSK	25	0	1	22.82
		16-QAM	1	0	1	23.05
		16-QAM		12		23.18
		16-QAM		24		23.32
		16-QAM	25	0	2	21.77
	23330 793	QPSK	1	0	0	23.77
		QPSK		12		23.88
		QPSK		24		23.99
		QPSK	25	0	1	22.85
		16-QAM	1	0	1	22.74
		16-QAM		12		23.08
		16-QAM		24		22.99
		16-QAM	25	0	2	21.96
	23355 795.5	QPSK	1	0	0	23.91
		QPSK		12		23.6
		QPSK		24		23.91
		QPSK	25	0	1	22.93
		16-QAM	1	0	1	23.02
		16-QAM		12		23.27
		16-QAM		24		23.15
		16-QAM	25	0	2	22.03

Band	Channel Freq. (MHz)	Modulation	RB No.	RB offset	MPR	Conducted Output Power (dBm)
Band 14 10MHz	23330 793	QPSK	1	0	0	24.09
		QPSK		24		23.75
		QPSK		49		23.79
		QPSK	50	0	1	22.98
		16-QAM	1	0	1	22.94
		16-QAM		24		23.16
		16-QAM		49		23.14
		16-QAM	50	0	2	22.02
Band	Channel Freq. (MHz)	Modulation	RB No.	RB offset	MPR	Conducted Output Power (dBm)
Band 14 5MHz	23305 790.5	64-QAM	1	0	1	22.67
		64-QAM		12		22.45
		64-QAM		24		22.47
		64-QAM	25	0	2	20.19
	23330 793	64-QAM	1	0	1	22.64
		64-QAM		12		22.45
		64-QAM		24		22.43
		64-QAM	25	0	2	21.94
	23355 795.5	64-QAM	1	0	1	22.63
		64-QAM		12		22.45
		64-QAM		24		22.56
		64-QAM	25	0	2	21.93
Band	Channel Freq. (MHz)	Modulation	RB No.	RB offset	MPR	Conducted Output Power (dBm)
Band 14 10MHz	23330 793	64-QAM	1	0	1	22.72
		64-QAM		24		22.59
		64-QAM		49		22.66
		64-QAM	50	0	2	22.18

Note:

This report is prepared for Class II permissive change. The difference compared with original report no.: 2050962R-E3042110012-A is housing and software. The software changes as following:

- 1) Add LTE band 4, band 12, band 14, band 29 and close band 13 by software.
- 2) Close 5G FR2 band n261 by software.

According to above conditions, LTE band 12/ 14 and added EN-DC combination testing and Radiated Spurious Emissions (RSE) worst-case need to be performed and all data were verified to meet the requirements, and other test data refer to original report.

3.5. Maximum Conducted Power and ERP/EIRP Power

According to KDB 412172 D01 Section 1.2 Power Approach

$$EIRP = P_T + G_T - L_C = ERP + 2.15 \text{ dB}, ERP = EIRP - 2.15 \text{ dB}$$

P_T = transmitter output power in dBm

G_T = gain of the transmitting antenna in dBi

L_C = signal attenuation in the connecting cable between the transmitter and antenna in dB

LTE B12 (700MHz)			ENDC 12A_n2: NR n2 Maximum power 0.29 dBm						
BW (MHz)	Channel	Modulation	LTE Power (dBm)	NR Power (dBm)	Total Power (dBm)	Total Power (W)	Antenna Gain (dBi)	Maximum ERP (W)	Maximum ERP Limit (W)
1.4	Low	QPSK	22.13	0.29	22.42	0.175	-0.87	0.087	3
		16QAM	21.01	0.29	21.30	0.135	-0.87	0.067	3
		64QAM	20.89	0.29	21.18	0.131	-0.87	0.065	3
	Mid	QPSK	21.97	0.29	22.26	0.168	-0.87	0.084	3
		16QAM	20.98	0.29	21.27	0.134	-0.87	0.067	3
		64QAM	20.48	0.29	20.77	0.119	-0.87	0.060	3
	High	QPSK	21.98	0.29	22.27	0.169	-0.87	0.084	3
		16QAM	21.20	0.29	21.49	0.141	-0.87	0.070	3
		64QAM	20.80	0.29	21.09	0.129	-0.87	0.064	3
3	Low	QPSK	22.15	0.29	22.44	0.175	-0.87	0.087	3
		16QAM	21.35	0.29	21.64	0.146	-0.87	0.073	3
		64QAM	20.64	0.29	20.93	0.124	-0.87	0.062	3
	Mid	QPSK	22.04	0.29	22.33	0.171	-0.87	0.085	3
		16QAM	21.16	0.29	21.45	0.140	-0.87	0.070	3
		64QAM	20.96	0.29	21.25	0.133	-0.87	0.067	3
	High	QPSK	22.14	0.29	22.43	0.175	-0.87	0.087	3
		16QAM	21.30	0.29	21.59	0.144	-0.87	0.072	3
		64QAM	20.88	0.29	21.17	0.131	-0.87	0.065	3

LTE B12 (700MHz)			ENDC 12A_n2: NR n2 Maximum power 0.29 dBm						
BW (MHz)	Channel	Modulation	LTE Power (dBm)	NR Power (dBm)	Total Power (dBm)	Total Power (W)	Antenna Gain (dBi)	Maximum ERP (W)	Maximum ERP Limit (W)
5	Low	QPSK	22.15	0.29	22.44	0.175	-0.87	0.087	3
		16QAM	22.13	0.29	22.42	0.175	-0.87	0.087	3
		64QAM	20.69	0.29	20.98	0.125	-0.87	0.063	3
	Mid	QPSK	22.13	0.29	22.42	0.175	-0.87	0.087	3
		16QAM	21.54	0.29	21.83	0.152	-0.87	0.076	3
		64QAM	20.53	0.29	20.82	0.121	-0.87	0.060	3
	High	QPSK	22.12	0.29	22.41	0.174	-0.87	0.087	3
		16QAM	21.08	0.29	21.37	0.137	-0.87	0.068	3
		64QAM	20.47	0.29	20.76	0.119	-0.87	0.059	3
10	Low	QPSK	22.28	0.29	22.57	0.181	-0.87	0.090	3
		16QAM	21.31	0.29	21.60	0.145	-0.87	0.072	3
		64QAM	20.85	0.29	21.14	0.130	-0.87	0.065	3
	Mid	QPSK	22.27	0.29	22.56	0.180	-0.87	0.090	3
		16QAM	21.21	0.29	21.50	0.141	-0.87	0.070	3
		64QAM	20.72	0.29	21.01	0.126	-0.87	0.063	3
	High	QPSK	22.26	0.29	22.55	0.180	-0.87	0.090	3
		16QAM	21.23	0.29	21.52	0.142	-0.87	0.071	3
		64QAM	20.83	0.29	21.12	0.129	-0.87	0.065	3

LTE B14 (700MHz)			ENDC 14A_n66: NR n66 Maximum power 0.35 dBm						
BW (MHz)	Channel	Modulation	LTE Power (dBm)	NR Power (dBm)	Total Power (dBm)	Total Power (W)	Antenna Gain (dBi)	Maximum ERP (W)	Maximum ERP Limit (W)
5	Low	QPSK	24.01	0.35	24.36	0.273	-1.12	0.129	3
		16QAM	23.05	0.35	23.40	0.219	-1.12	0.103	3
		64QAM	22.67	0.35	23.02	0.200	-1.12	0.094	3
	Mid	QPSK	23.77	0.35	24.12	0.258	-1.12	0.122	3
		16QAM	22.74	0.35	23.09	0.204	-1.12	0.096	3
		64QAM	22.64	0.35	22.99	0.199	-1.12	0.094	3
	High	QPSK	23.91	0.35	24.26	0.267	-1.12	0.126	3
		16QAM	23.02	0.35	23.37	0.217	-1.12	0.102	3
		64QAM	22.63	0.35	22.98	0.199	-1.12	0.094	3
10	Mid	QPSK	24.09	0.35	24.44	0.278	-1.12	0.131	3
		16QAM	22.94	0.35	23.29	0.213	-1.12	0.100	3
		64QAM	22.72	0.35	23.07	0.203	-1.12	0.095	3

Note:

This report is prepared for Class II permissive change. The difference compared with original report no.: 2050962R-E3042110012-A is housing and software. The software changes as following:

- 1) Add LTE band 4, band 12, band 14, band 29 and close band 13 by software.
- 2) Close 5G FR2 band n261 by software.

According to above conditions, LTE band 12/ 14 and added EN-DC combination testing and Radiated Spurious Emissions (RSE) worst-case need to be performed and all data were verified to meet the requirements, and other test data refer to original report.

4. Occupied Bandwidth

4.1. Test Setup

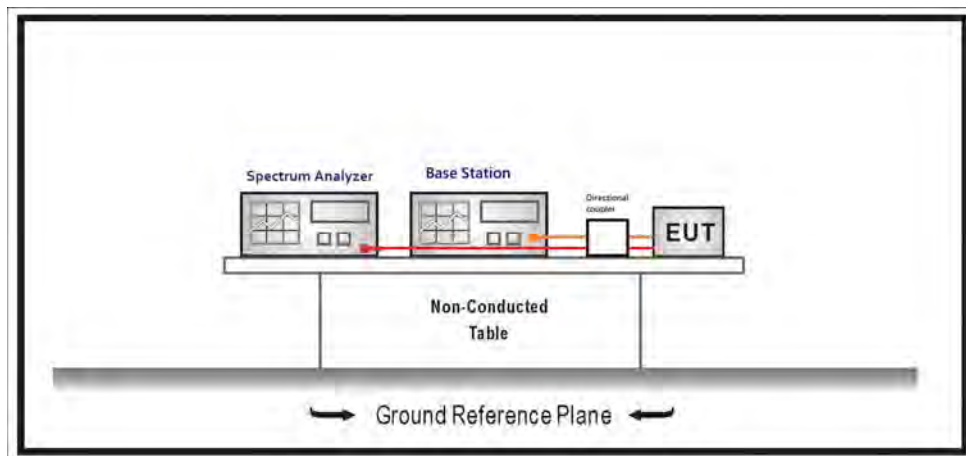

4.2. Test Procedure

1. The EUT was connected to Spectrum Analyzer and Base Station via power divider.
2. The RF output of EUT was connected to the spectrum analyzer by RF cable and attenuator. The path loss was compensated to the results for each measurement.
3. The 26 dB bandwidth and 99% occupied bandwidth of the low & middle & high channel for the highest RF powers were measured.

4.3. Test Method

KDB 971168 D01 Power Meas License Digital Systems v03 sub-clause 4.2 & 4.3
ANSI C63.26-2015 Sub-clause 5.4.3 & 5.4.4

4.4. Test Result

Product	5G CPE		
Test Item	Occupied Bandwidth		
Test Mode	Mode 1: ENDC 12A_n2		
Date of Test	2020/11/27	Test Site	SR12-H
Temperature (°C)	22	Humidity (%RH)	63

LTE Band12_Full RB					
Bandwidth (MHz)	Modulation	Frequency (MHz)	Measure Level (MHz)		Limit (MHz)
			26dB BW	99% BW	
1.4M	QPSK	699.7	1.214	1.078	N/A
		707.5	1.204	1.086	N/A
		715.3	1.214	1.079	N/A
	16-QAM	699.7	1.196	1.078	N/A
		707.5	1.219	1.080	N/A
		715.3	1.201	1.078	N/A
	64-QAM	699.7	1.195	1.077	N/A
		707.5	1.214	1.081	N/A
		715.3	1.204	1.079	N/A
3M	QPSK	700.5	2.945	2.689	N/A
		707.5	2.951	2.692	N/A
		714.5	2.933	2.687	N/A
	16-QAM	700.5	2.940	2.683	N/A
		707.5	2.940	2.686	N/A
		714.5	2.930	2.683	N/A
	64-QAM	700.5	2.945	2.683	N/A
		707.5	2.940	2.685	N/A
		714.5	2.939	2.684	N/A

Bandwidth (MHz)	Modulation	Frequency (MHz)	Measure Level (MHz)		Limit (MHz)
			26dB BW	99% BW	
5M	QPSK	701.5	4.681	4.463	N/A
		707.5	4.872	4.471	N/A
		713.5	4.881	4.480	N/A
	16-QAM	701.5	4.836	4.467	N/A
		707.5	4.934	4.478	N/A
		713.5	4.670	4.461	N/A
	64-QAM	701.5	4.832	4.468	N/A
		707.5	4.936	4.476	N/A
		713.5	4.895	4.479	N/A
10M	QPSK	704.0	9.675	8.947	N/A
		707.5	9.728	8.957	N/A
		711.0	9.622	8.929	N/A
	16-QAM	704.0	9.610	8.934	N/A
		707.5	9.779	8.961	N/A
		711.0	9.634	8.932	N/A
	64-QAM	704.0	9.640	8.942	N/A
		707.5	9.716	8.957	N/A
		711.0	9.643	8.936	N/A

LTE_B12_CH23017_1.4M_QPSK_6RB0

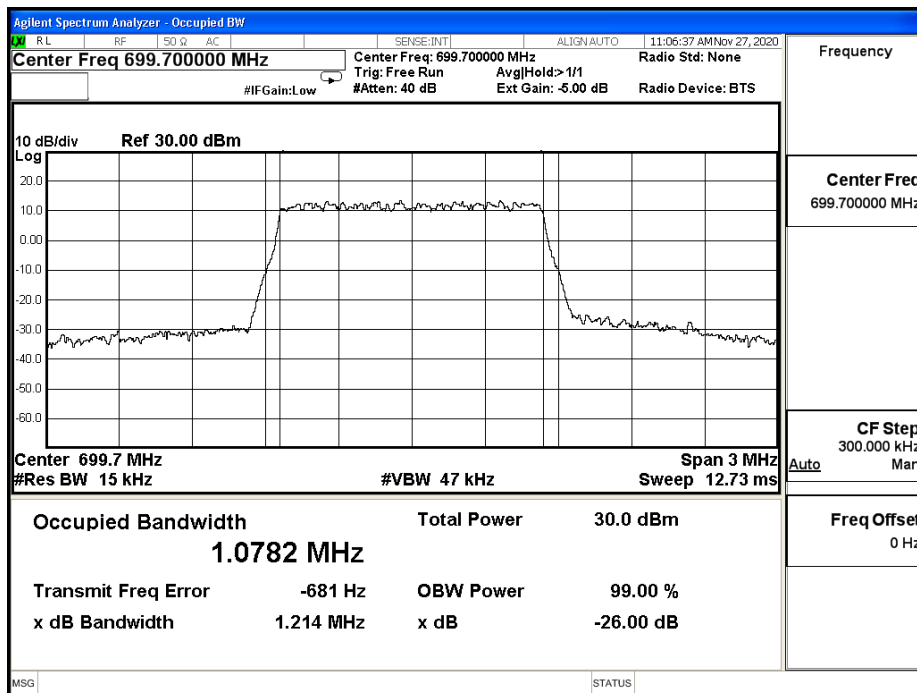

LTE_B12_CH23017_1.4M_16-QAM_6RB0

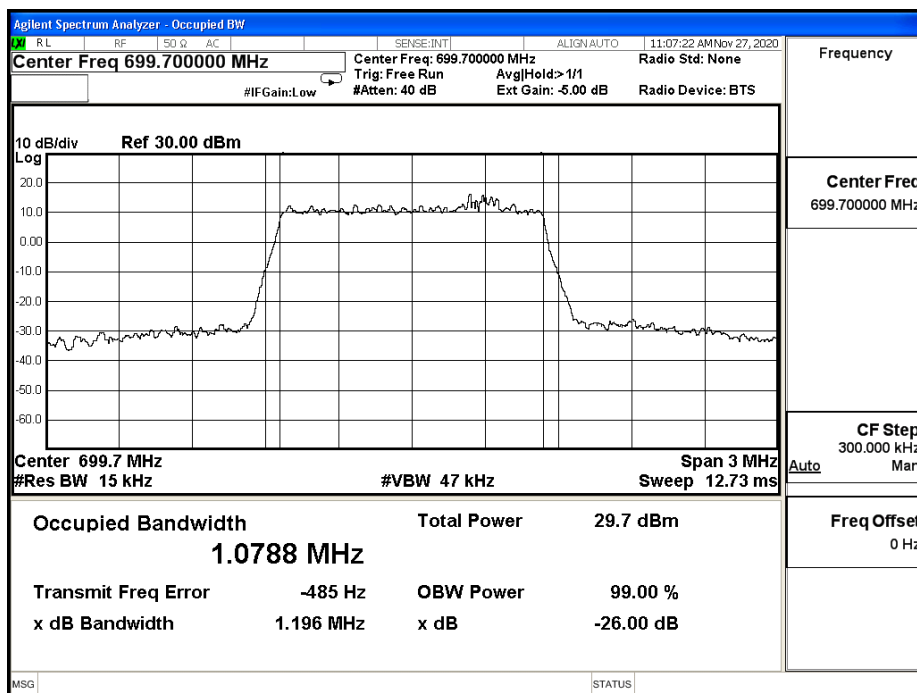

LTE_B12_CH23017_1.4M_64-QAM_6RB0

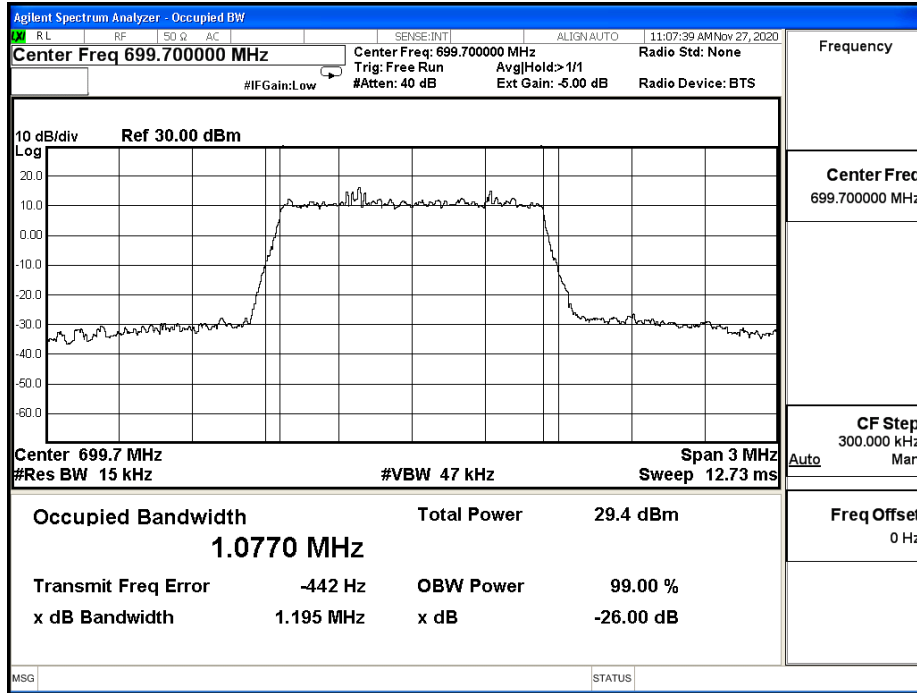

LTE_B12_CH23095_1.4M_QPSK_6RB0

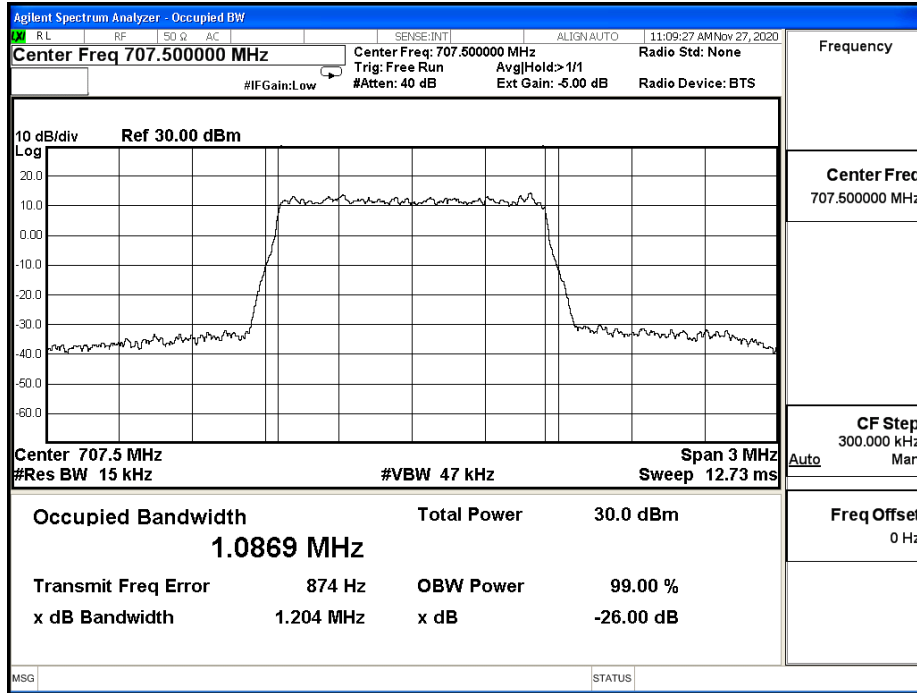

LTE_B12_CH23095_1.4M_16-QAM_6RB0

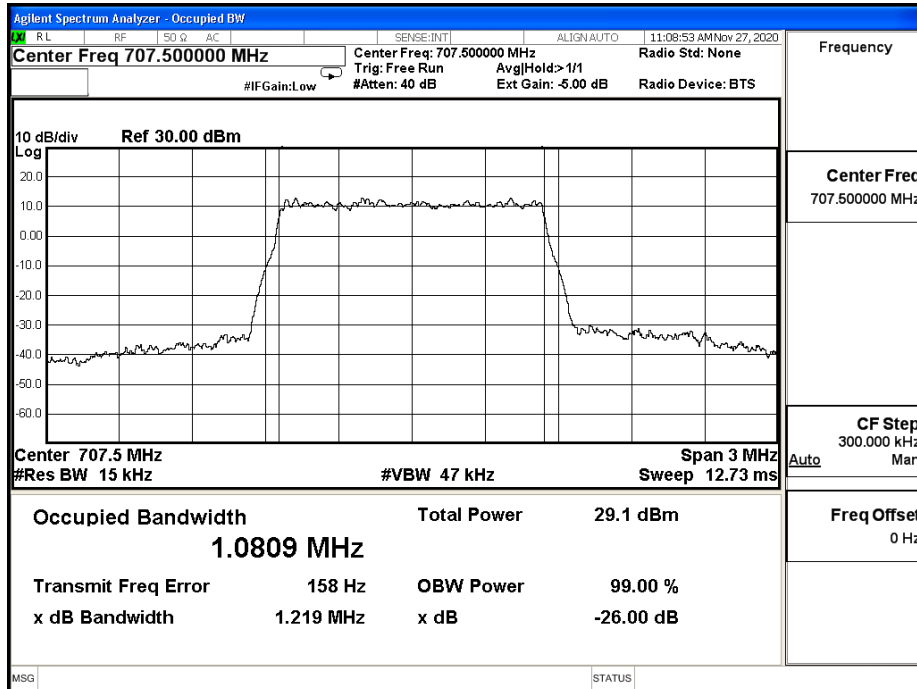

LTE_B12_CH23095_1.4M_64-QAM_6RB0

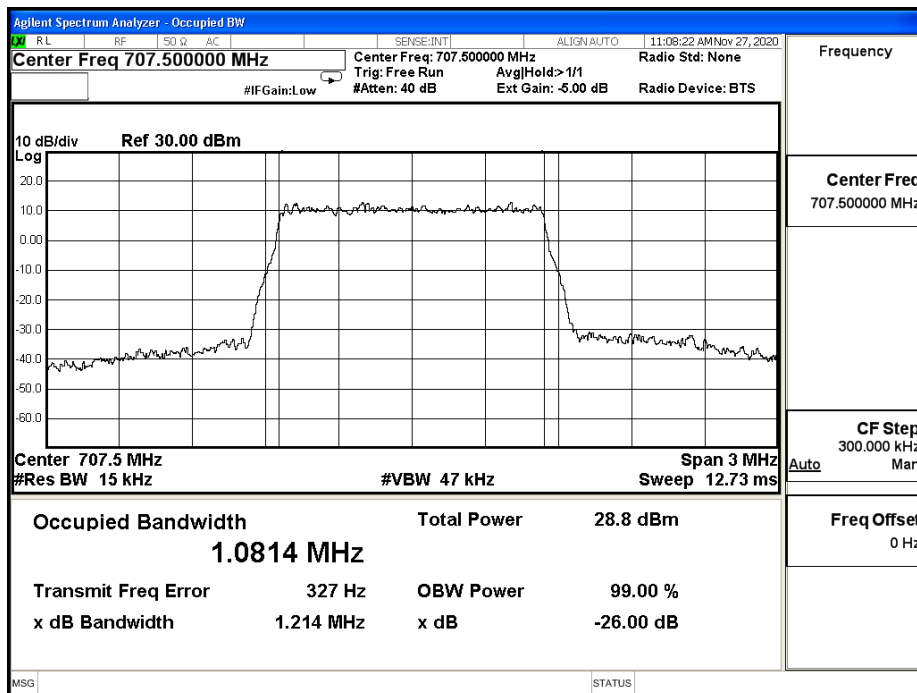

LTE_B12_CH23173_1.4M_QPSK_6RB0

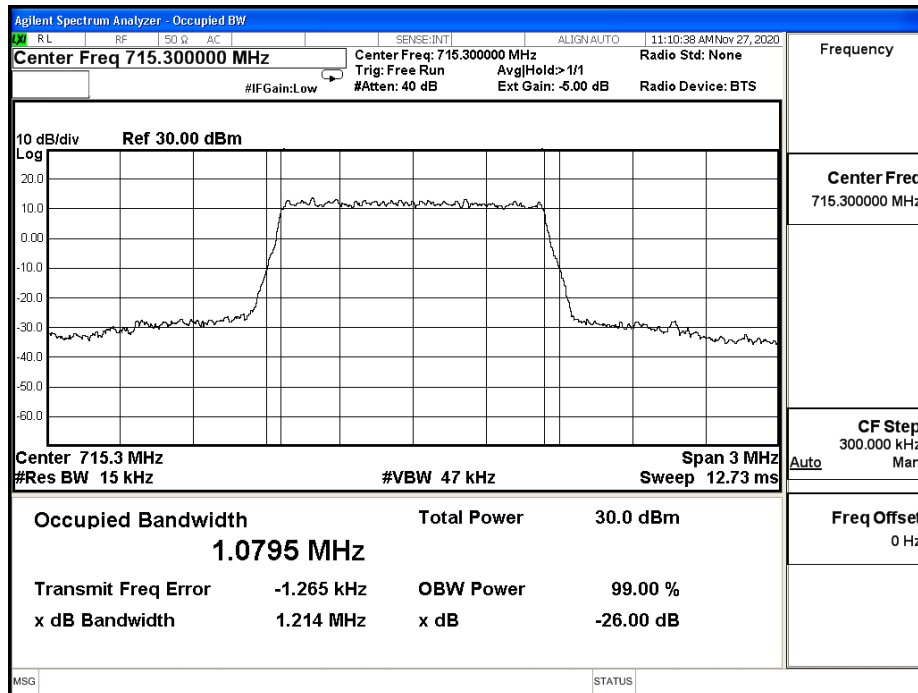

LTE_B12_CH23173_1.4M_16-QAM_6RB0

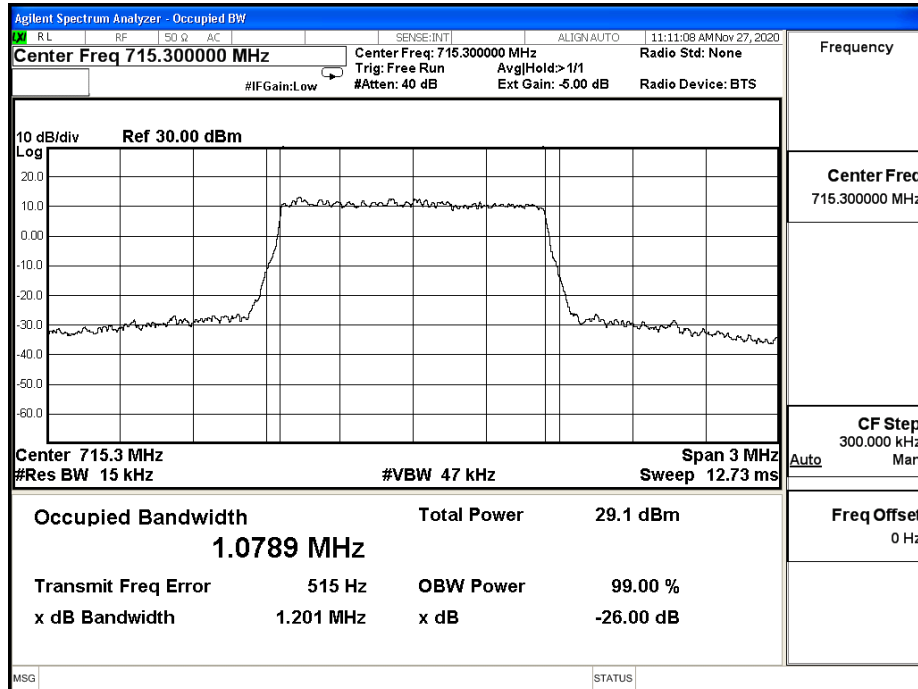

LTE_B12_CH23173_1.4M_64-QAM_6RB0

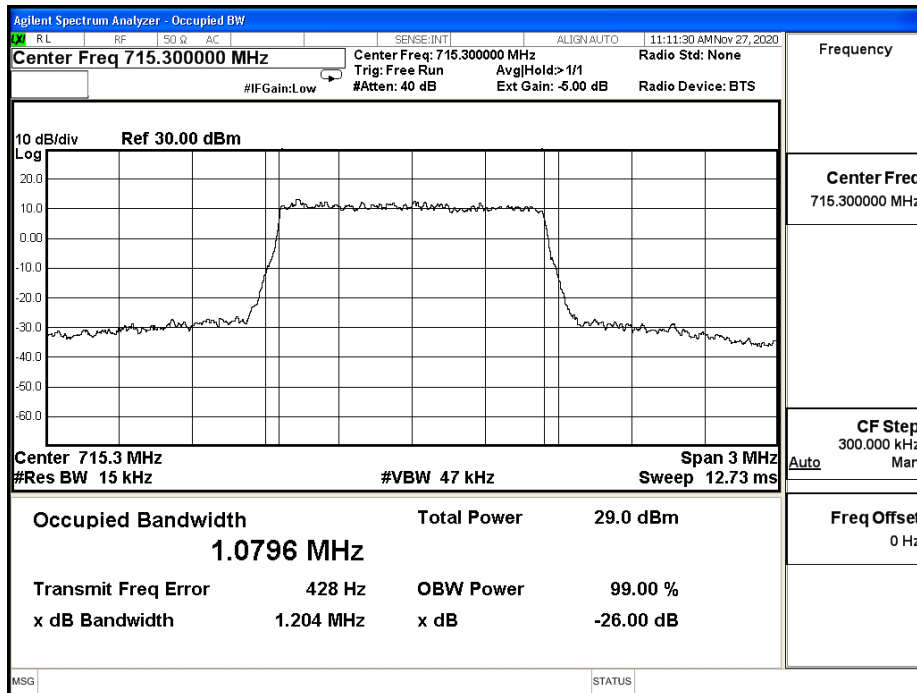

LTE_B12_CH23025_3M_QPSK_15RB0

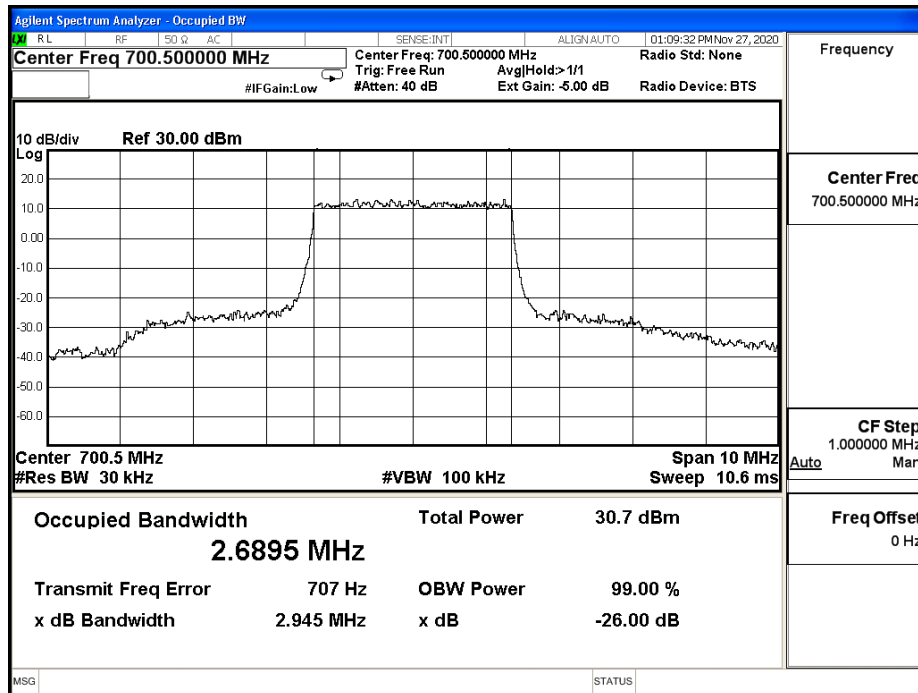

LTE_B12_CH23025_3M_16-QAM_15RB0

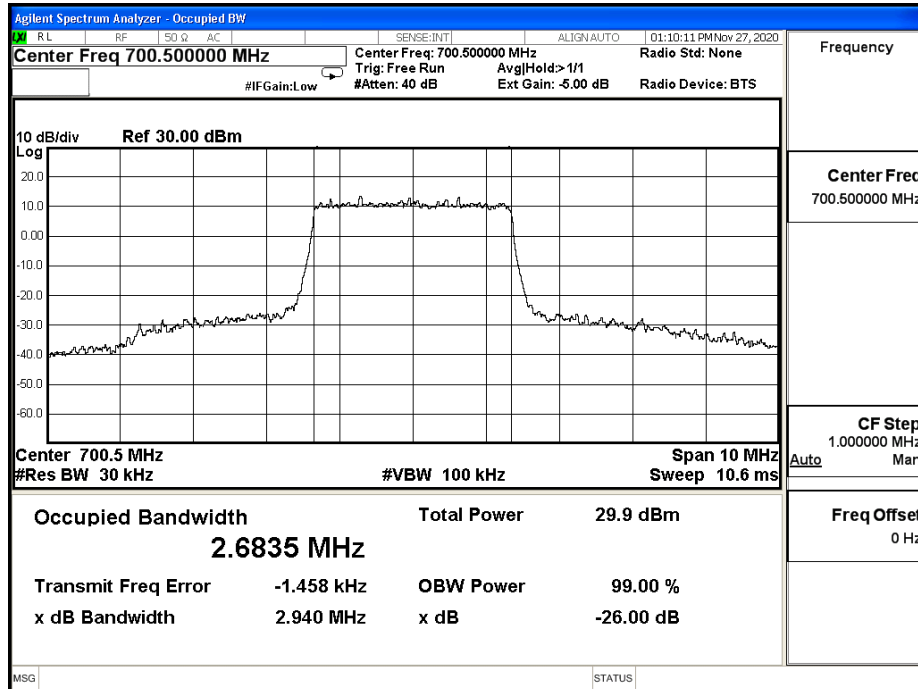

LTE_B12_CH23025_3M_64-QAM_15RB0

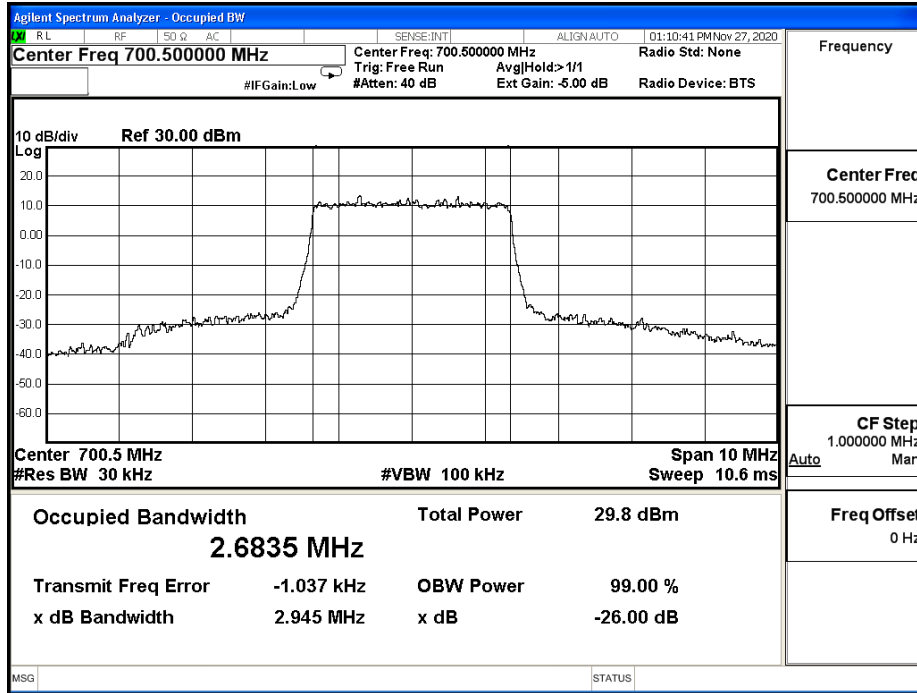

LTE_B12_CH23095_3M_QPSK_15RB0

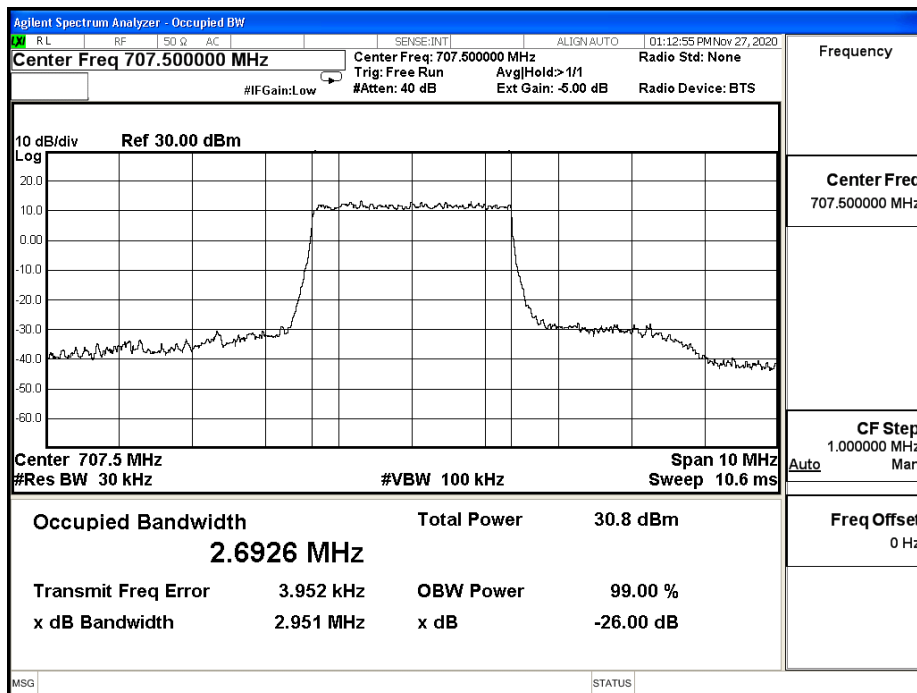

LTE_B12_CH23095_3M_16-QAM_15RB0

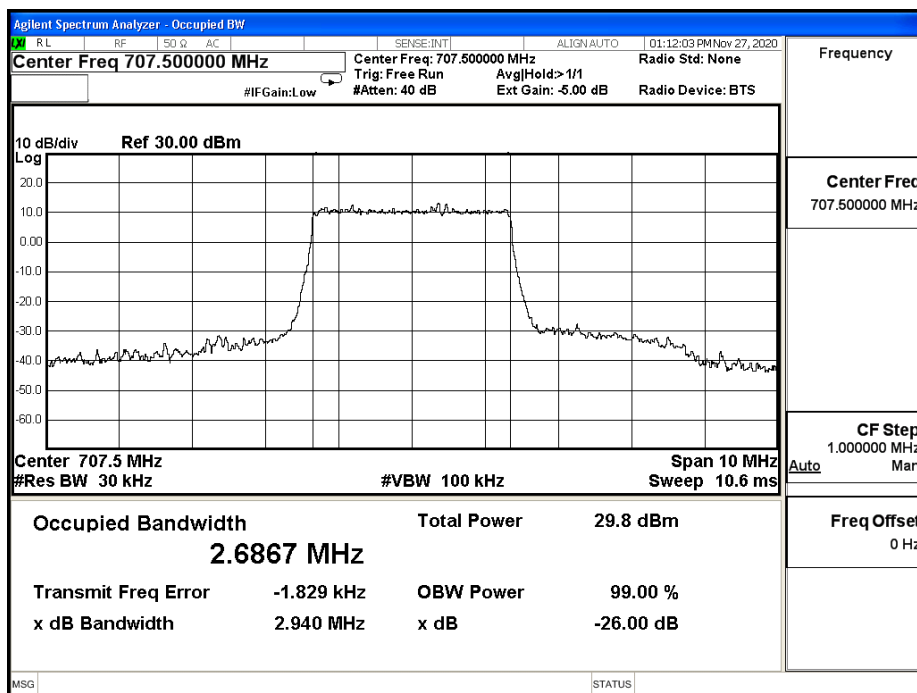

LTE_B12_CH23095_3M_64-QAM_15RB0

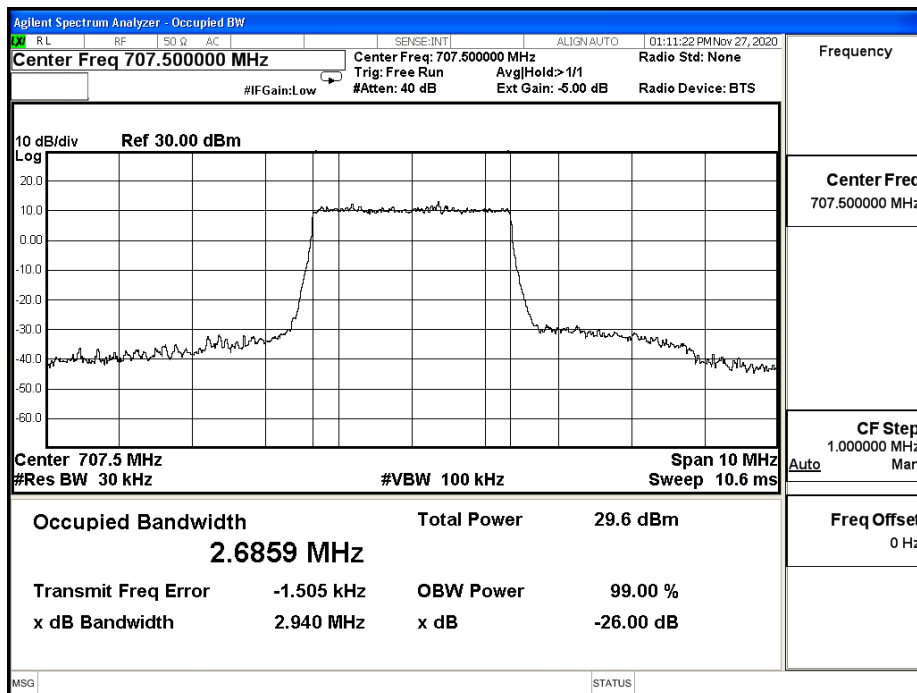

LTE_B12_CH23165_3M_QPSK_15RB0

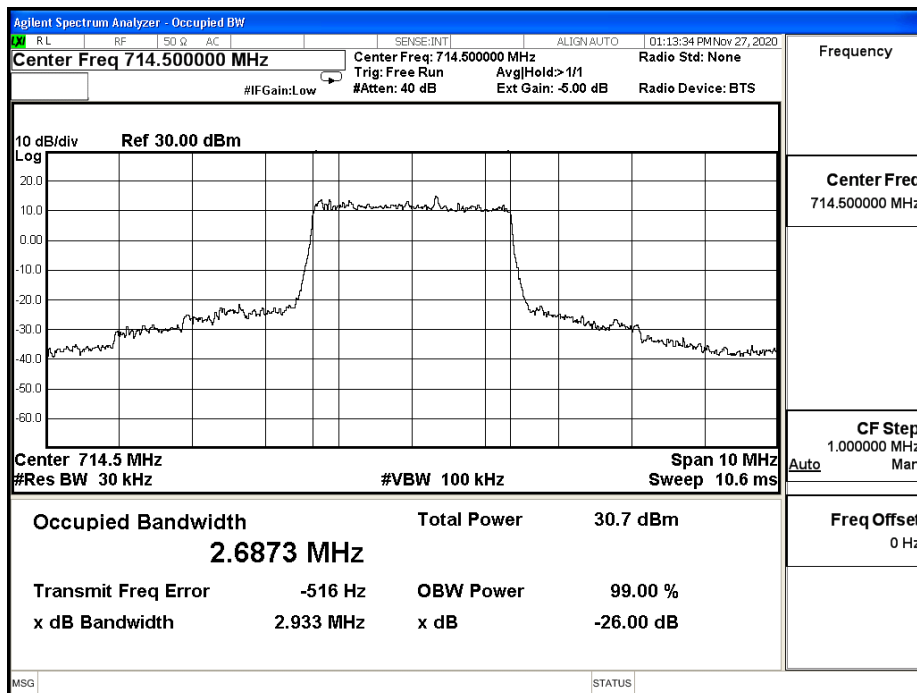

LTE_B12_CH23165_3M_16-QAM_15RB0

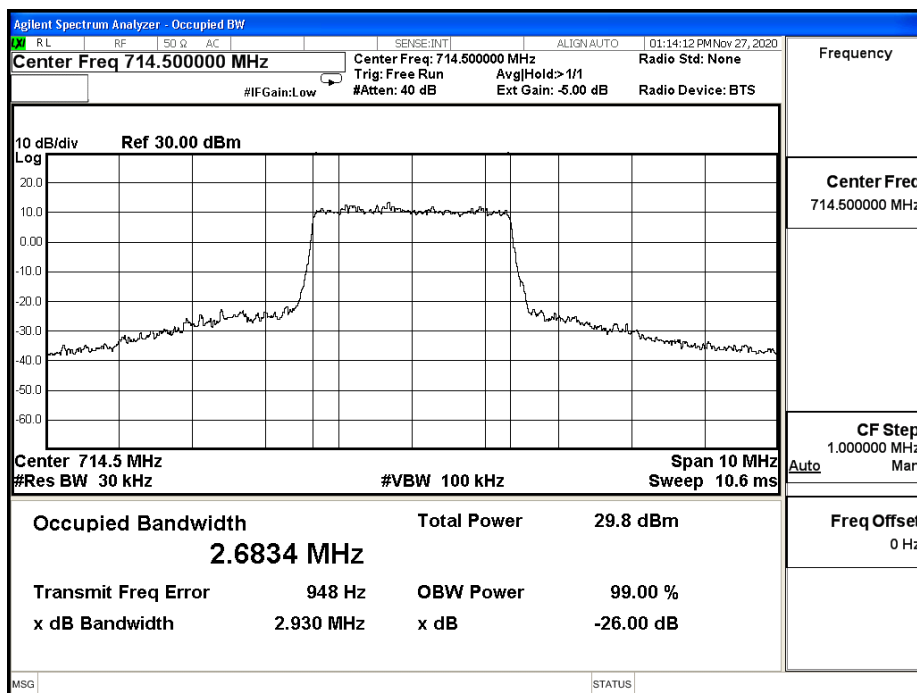

LTE_B12_CH23165_3M_64-QAM_15RB0

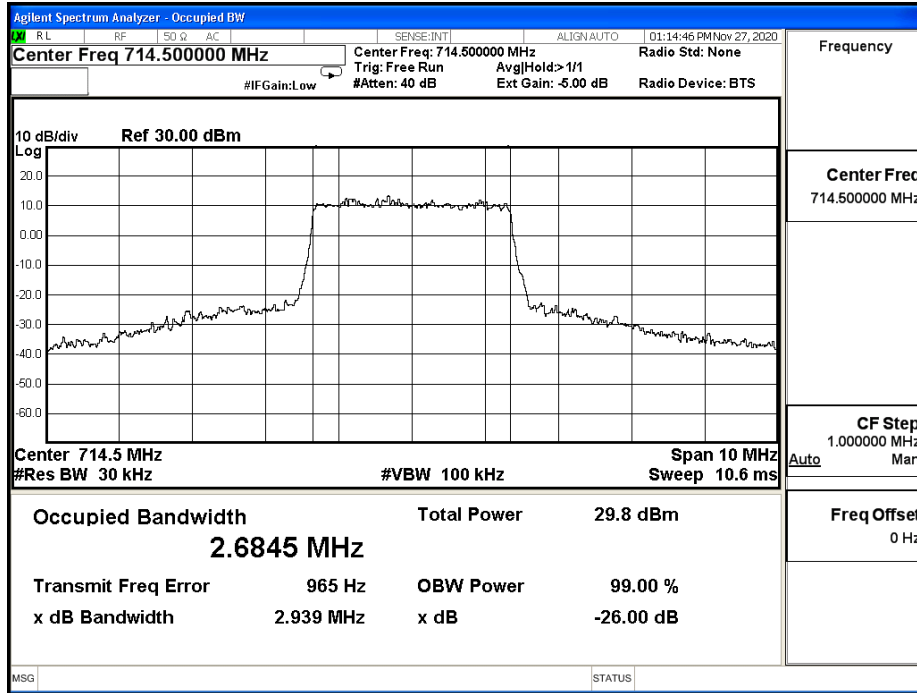

LTE_B12_CH23035_5M_QPSK_25RB0

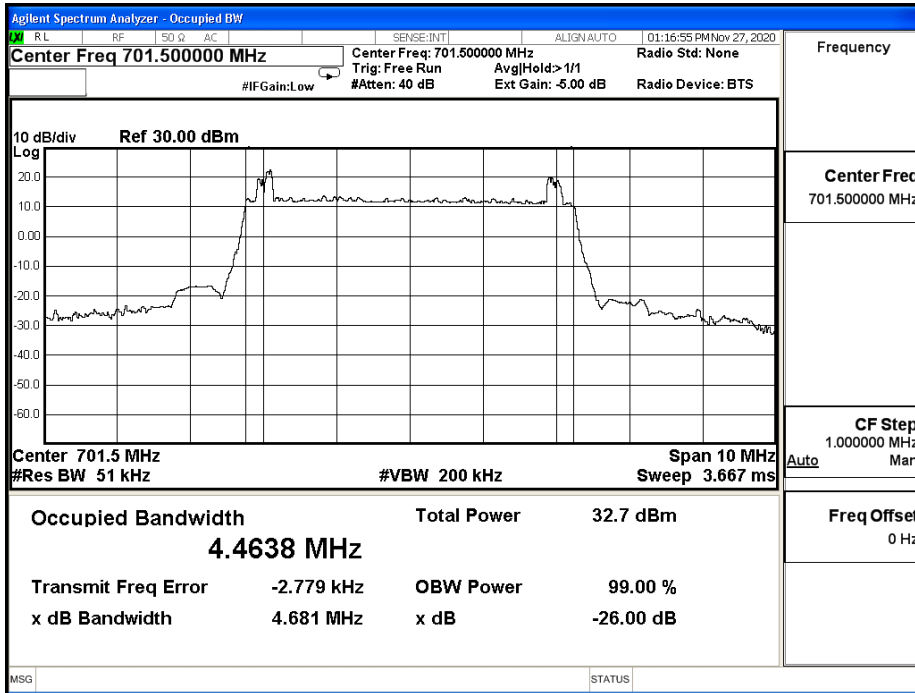

LTE_B12_CH23035_5M_16-QAM_25RB0

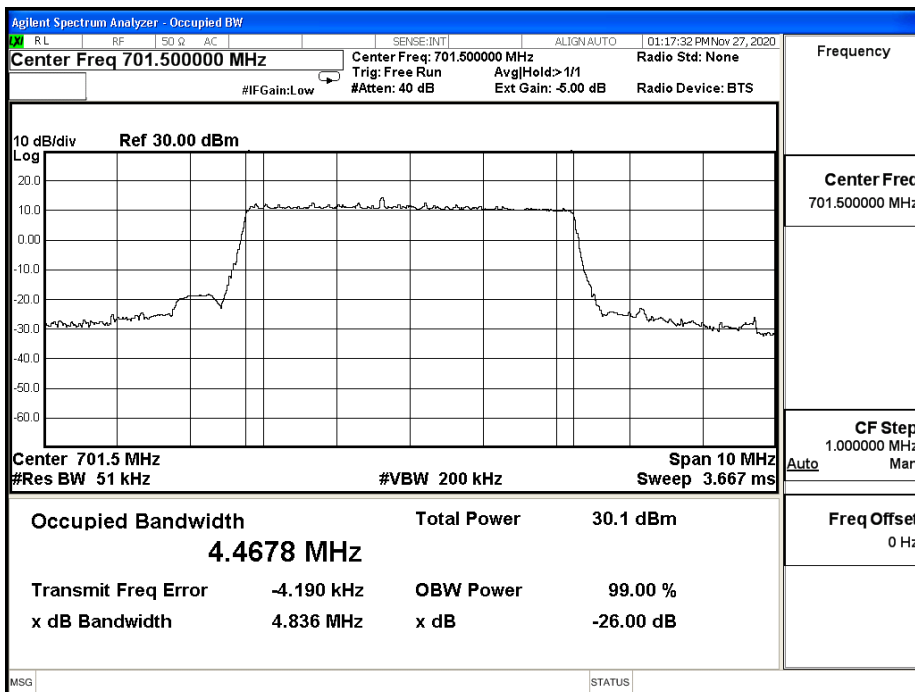

LTE_B12_CH23035_5M_64-QAM_25RB0

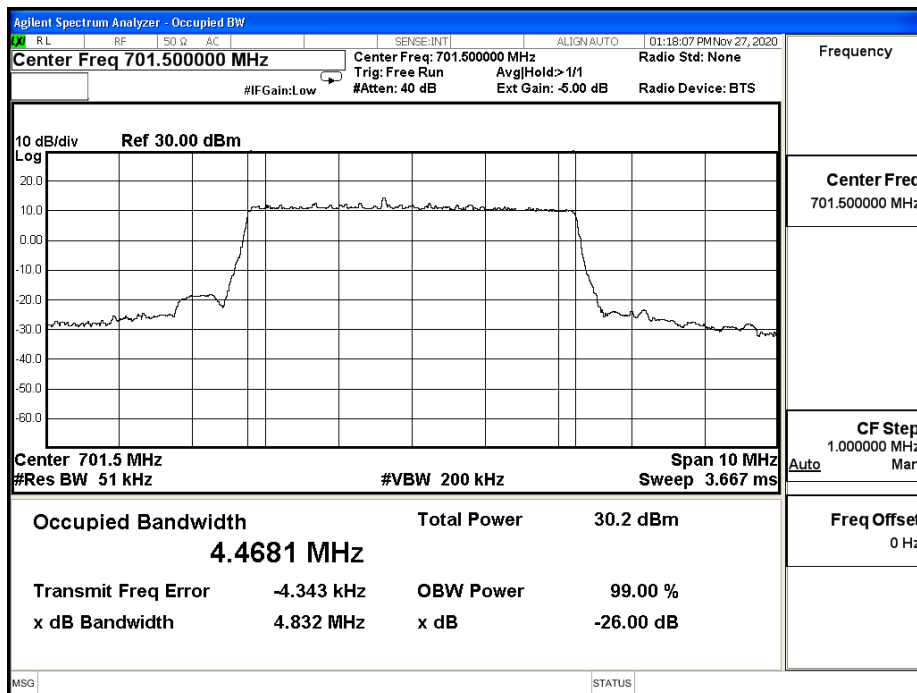

LTE_B12_CH23095_5M_QPSK_25RB0

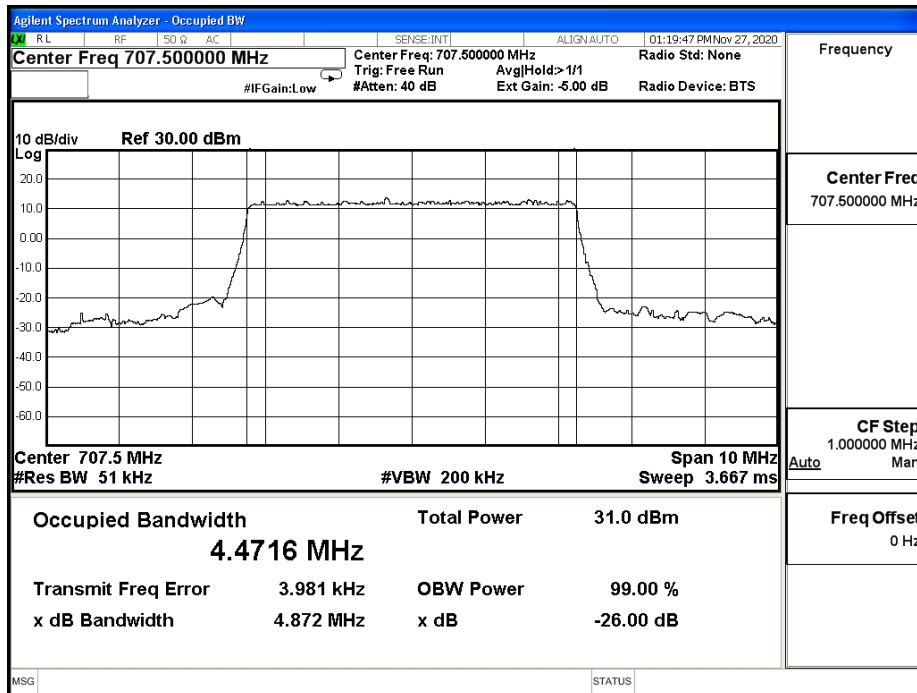

LTE_B12_CH23095_5M_16-QAM_25RB0

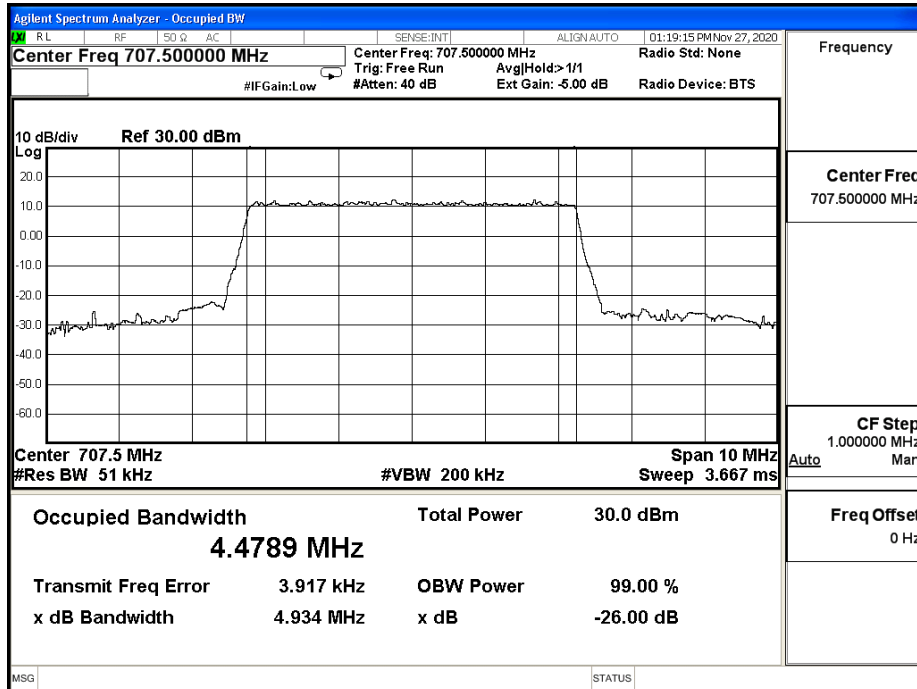

LTE_B12_CH23095_5M_64-QAM_25RB0

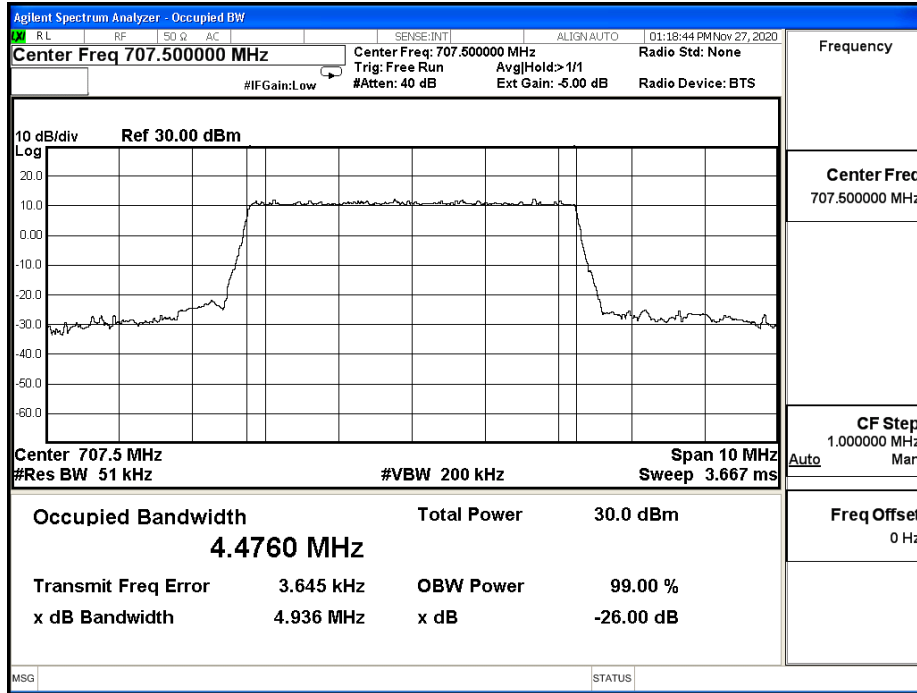

LTE_B12_CH23155_5M_QPSK_25RB0

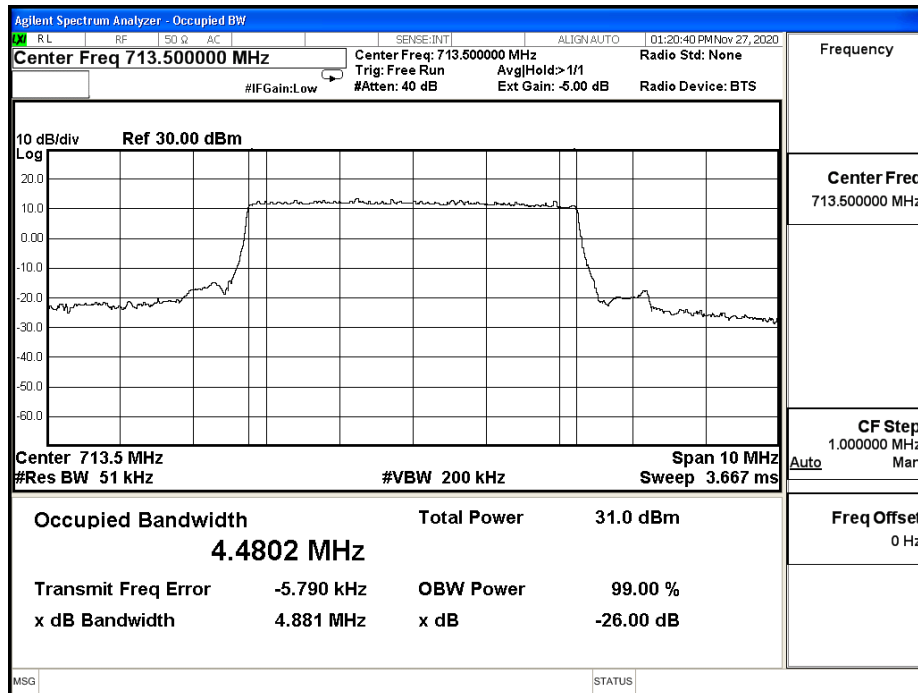

LTE_B12_CH23155_5M_16-QAM_25RB0

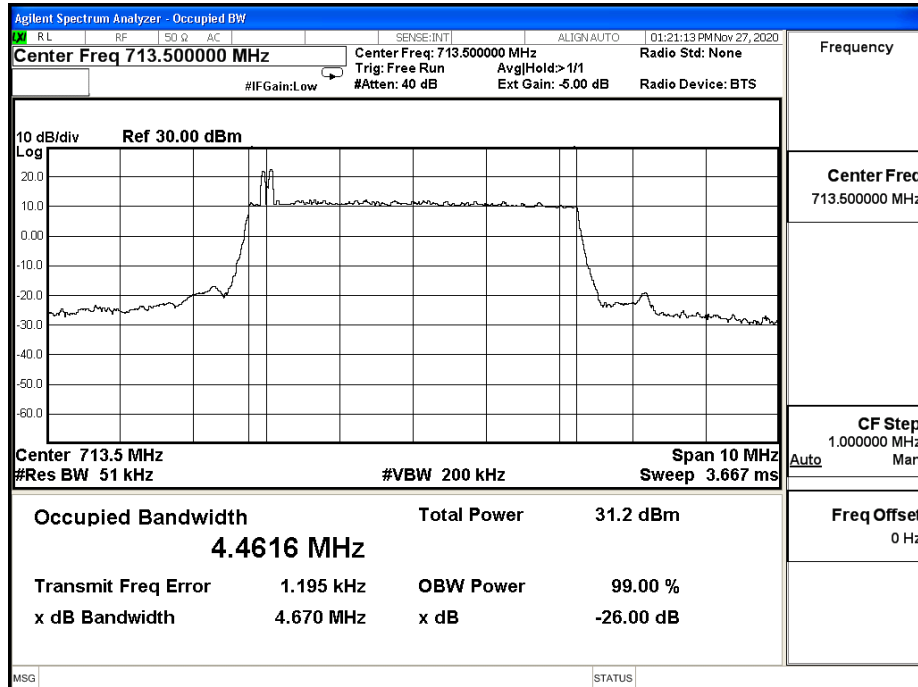

LTE_B12_CH23155_5M_64-QAM_25RB0

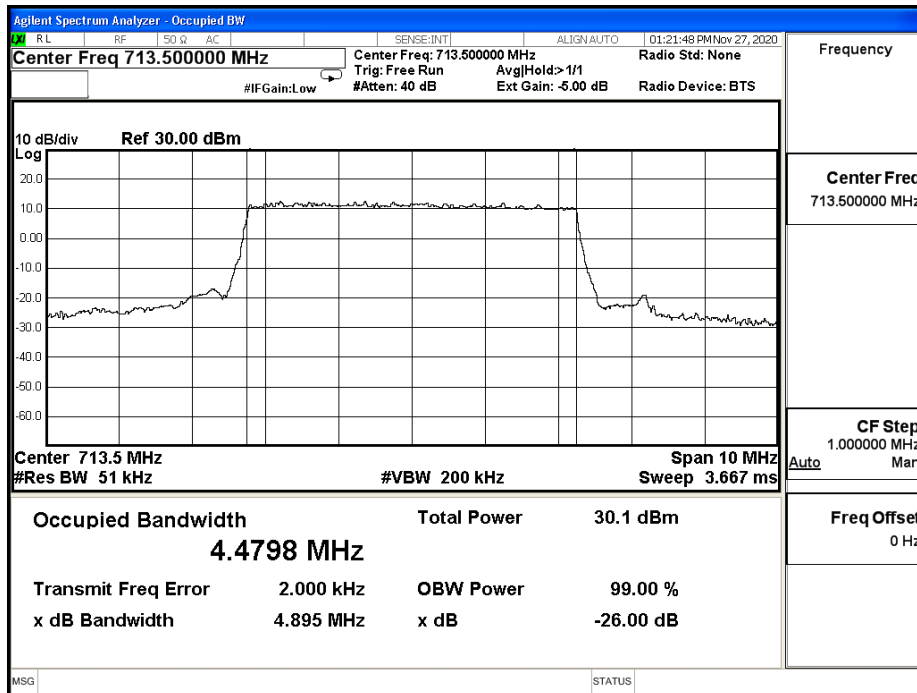

LTE_B12_CH23060_10M_QPSK_50RB0

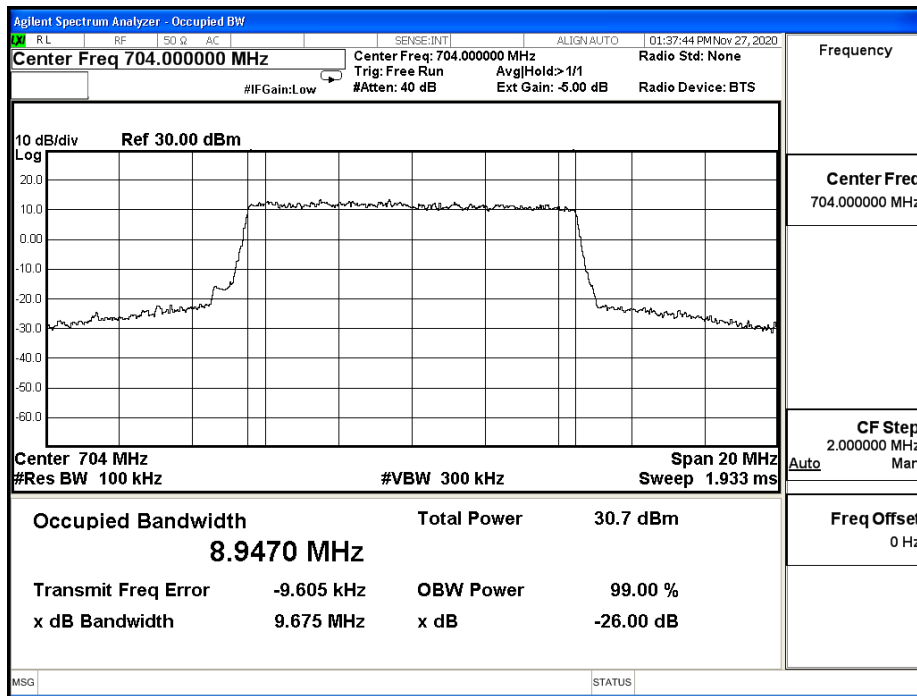

LTE_B12_CH23060_10M_16-QAM_50RB0

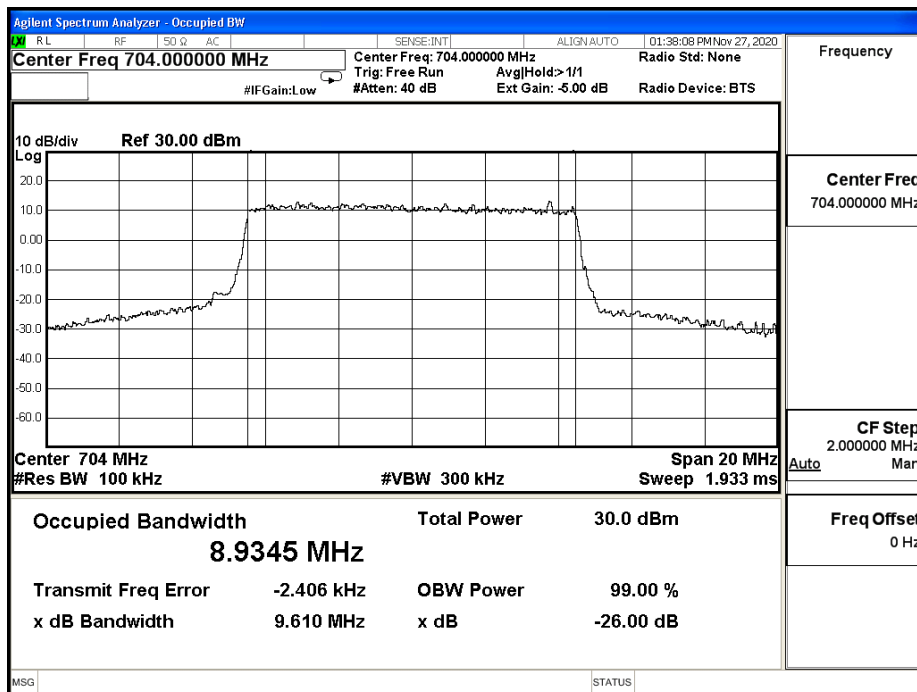

LTE_B12_CH23060_10M_64-QAM_50RB0

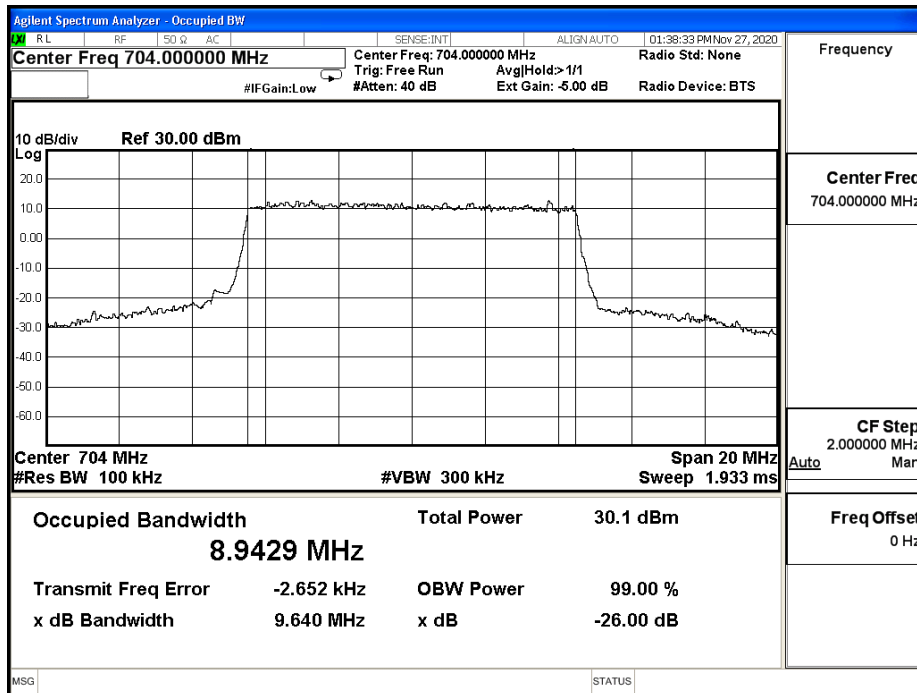

LTE_B12_CH23095_10M_QPSK_50RB0

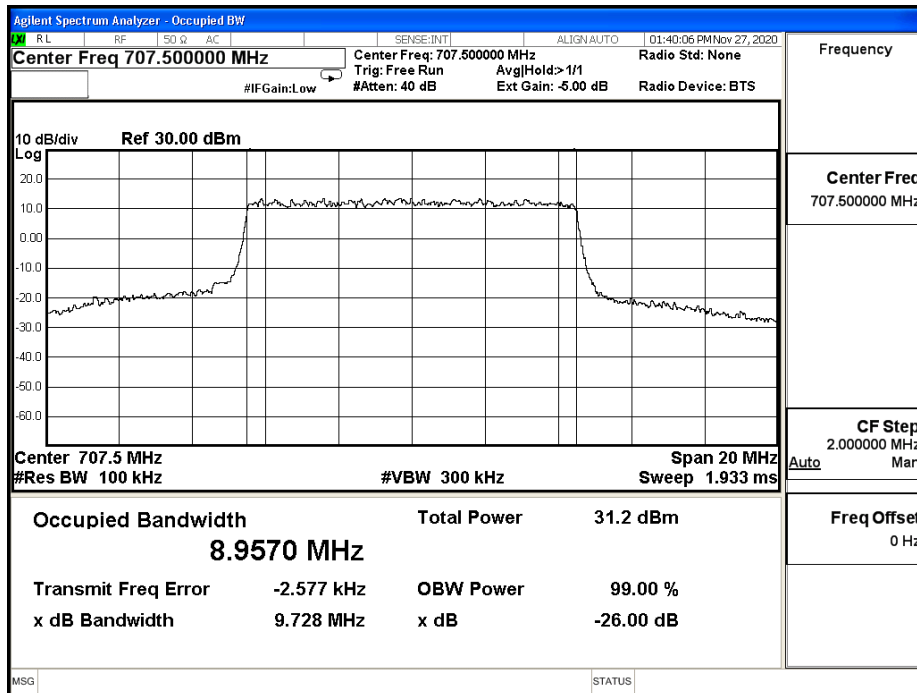

LTE_B12_CH23095_10M_16-QAM_50RB0

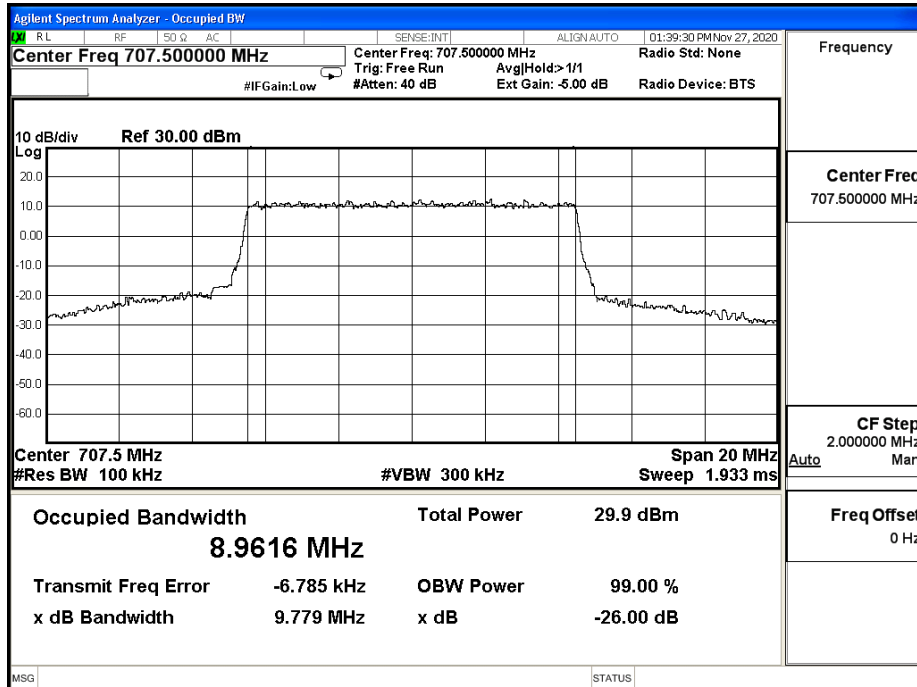

LTE_B12_CH23095_10M_64-QAM_50RB0

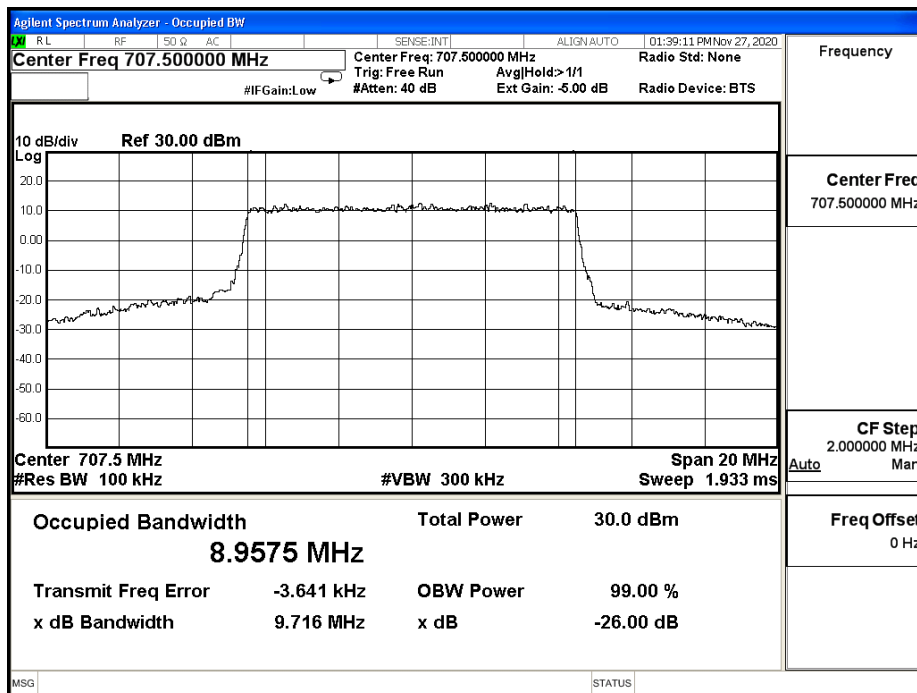

LTE_B12_CH23130_10M_QPSK_50RB0

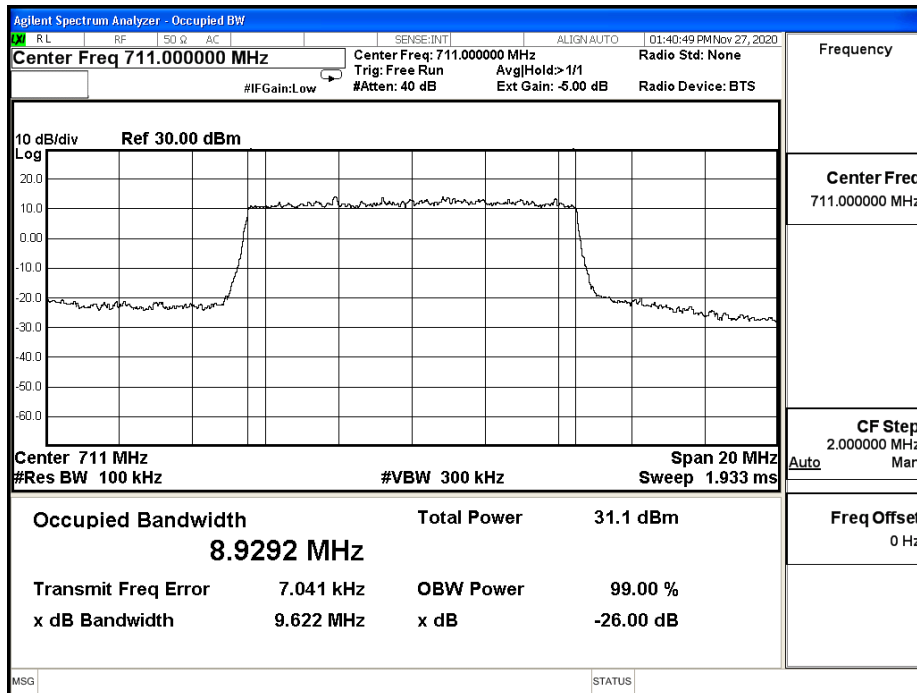

LTE_B12_CH23130_10M_16-QAM_50RB0

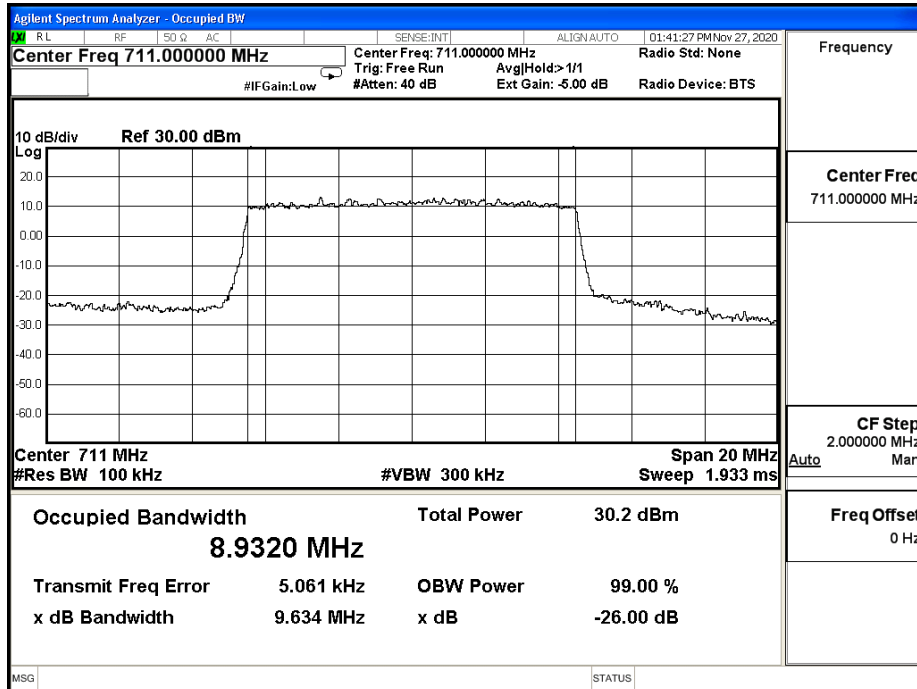

LTE_B12_CH23130_10M_64-QAM_50RB0

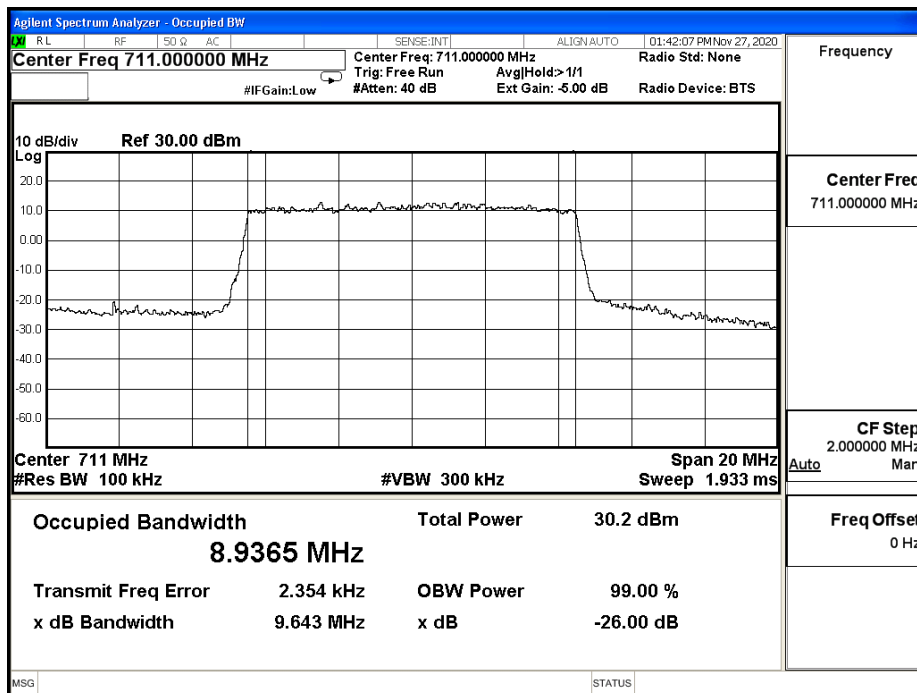

Product	5G CPE		
Test Item	Occupied Bandwidth		
Test Mode	Mode 2: ENDC 14A_n66		
Date of Test	2020/11/27	Test Site	SR12-H
Temperature (°C)	22	Humidity (%RH)	63

LTE Band14_Full RB					
Bandwidth (MHz)	Modulation	Frequency (MHz)	Measure Level (MHz)		Limit (MHz)
			26dB BW	99% BW	
5M	QPSK	790.5	4.887	4.471	N/A
		793	4.884	4.477	N/A
		795.5	4.898	4.484	N/A
	16-QAM	790.5	4.923	4.480	N/A
		793	4.903	4.480	N/A
		795.5	4.822	4.470	N/A
	64-QAM	790.5	4.920	4.480	N/A
		793	4.887	4.480	N/A
		795.5	4.848	4.467	N/A
10M	QPSK	793	9.721	8.940	N/A
	16-QAM	793	9.581	8.937	N/A
	64-QAM	793	9.623	8.940	N/A

LTE_B14_CH23305_5M_QPSK_25RB0

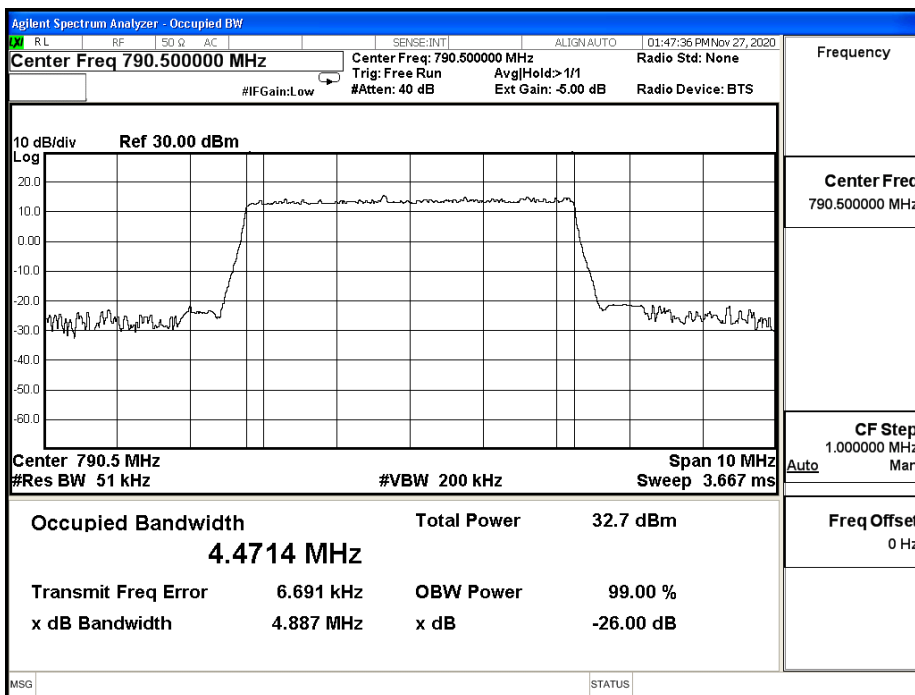

LTE_B14_CH23305_5M_16-QAM_25RB0

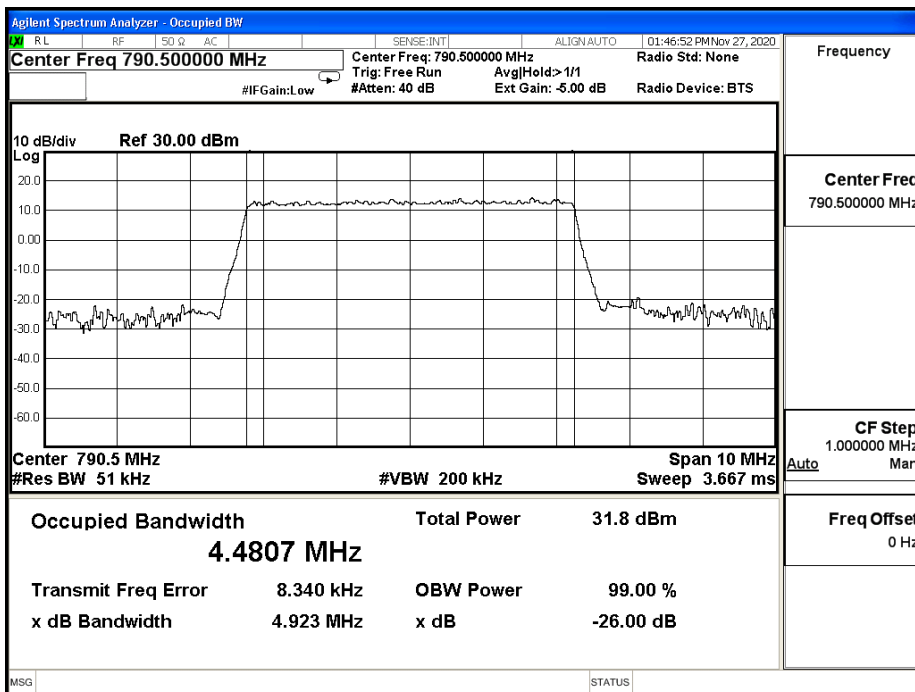

LTE_B14_CH23305_5M_64-QAM_25RB0

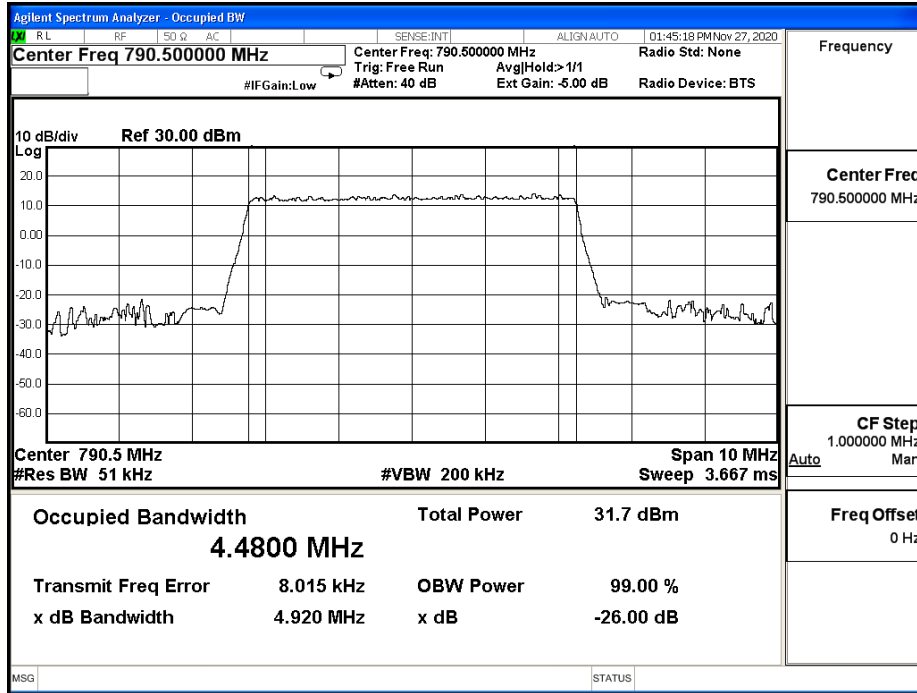

LTE_B14_CH23330_5M_QPSK_25RB0

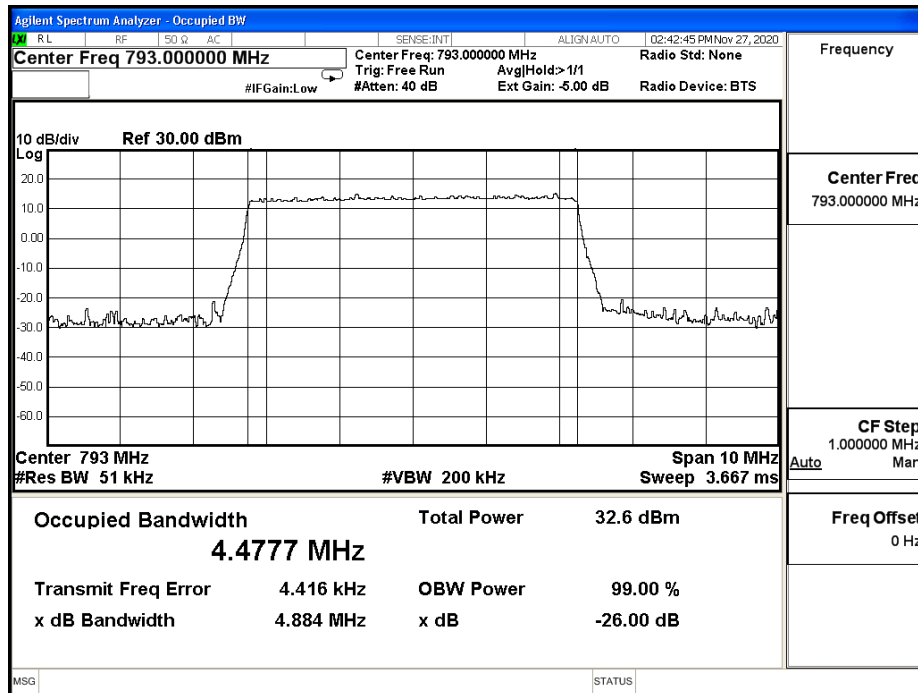

LTE_B14_CH23330_5M_16-QAM_25RB0

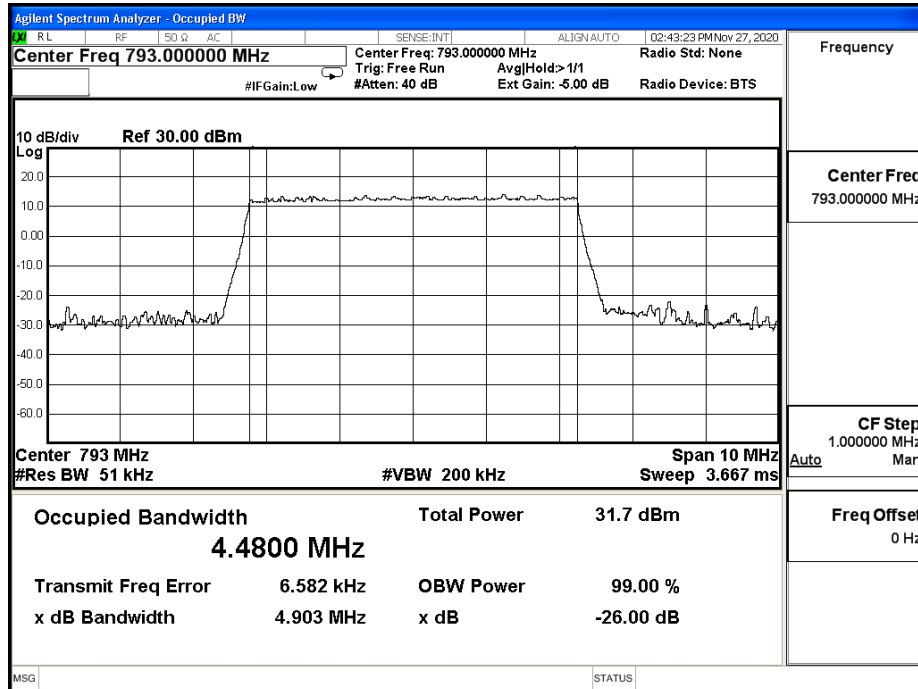

LTE_B14_CH23330_5M_64-QAM_25RB0

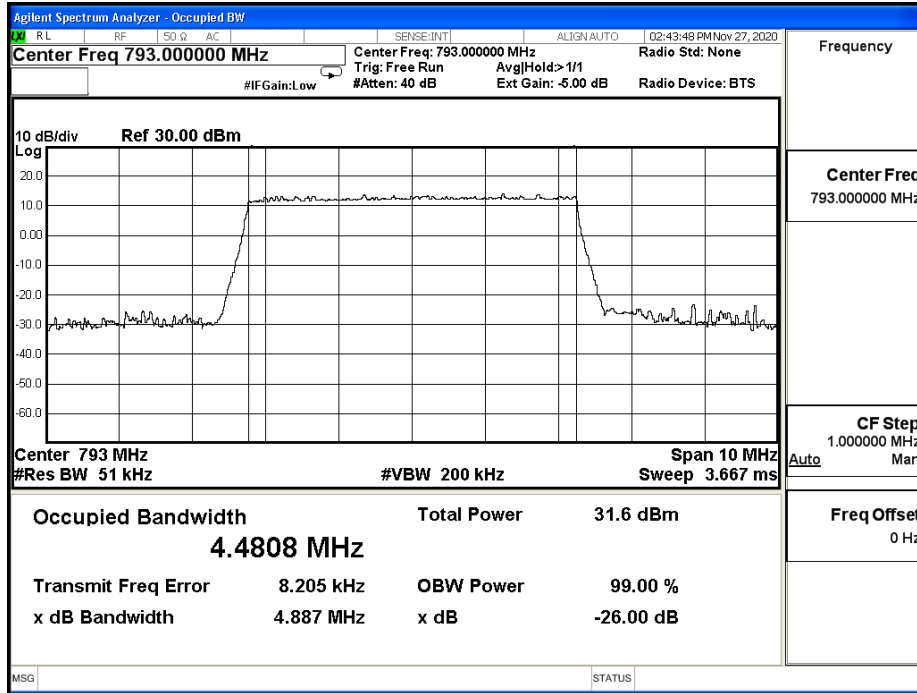

LTE_B14_CH23355_5M_QPSK_25RB0

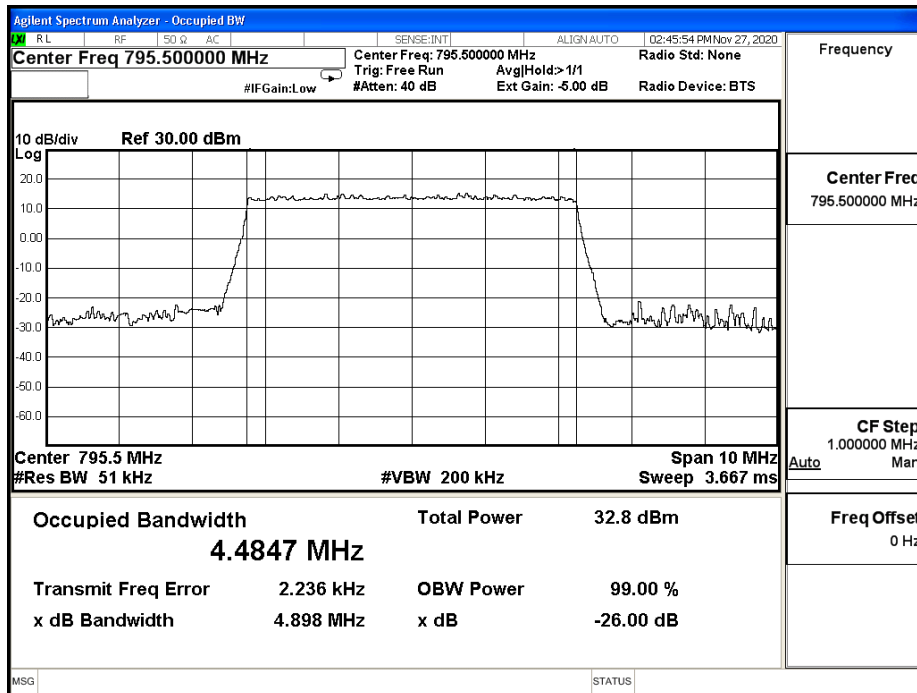

LTE_B14_CH23355_5M_16-QAM_25RB0

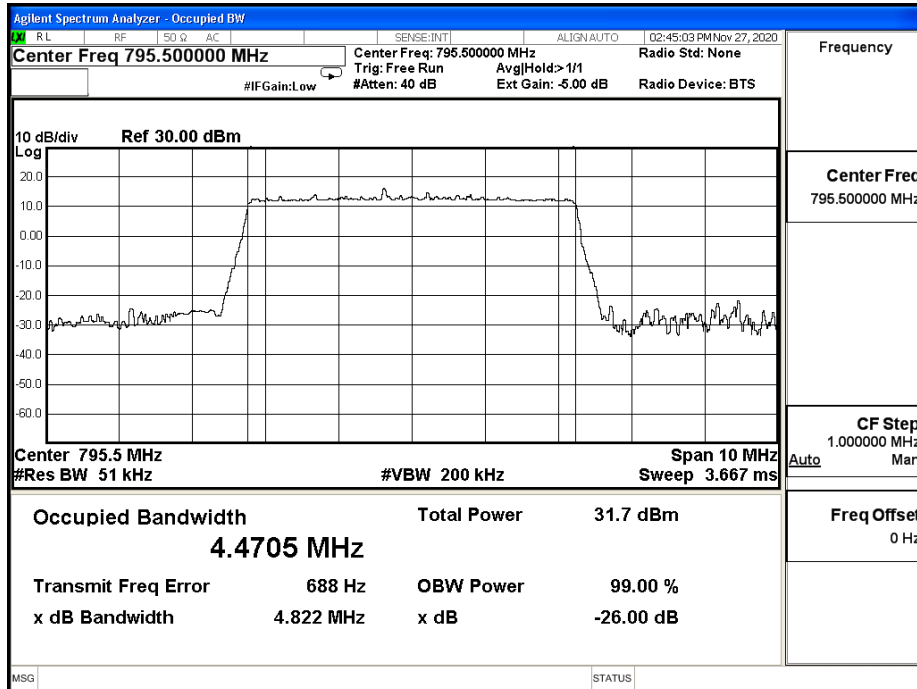

LTE_B14_CH23355_5M_64-QAM_25RB0

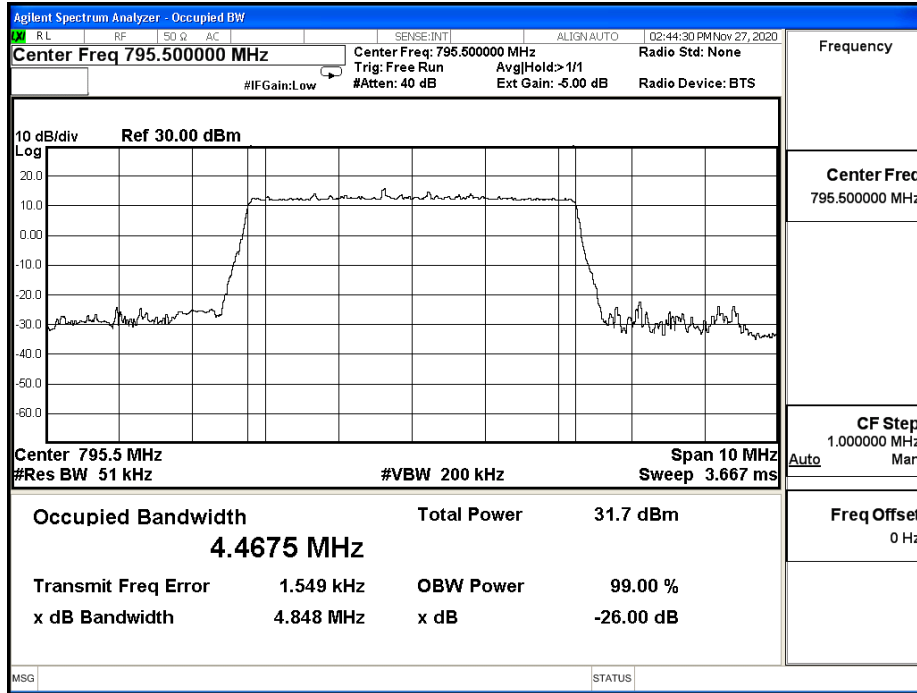

LTE_B14_CH23330_10M_QPSK_50RB0

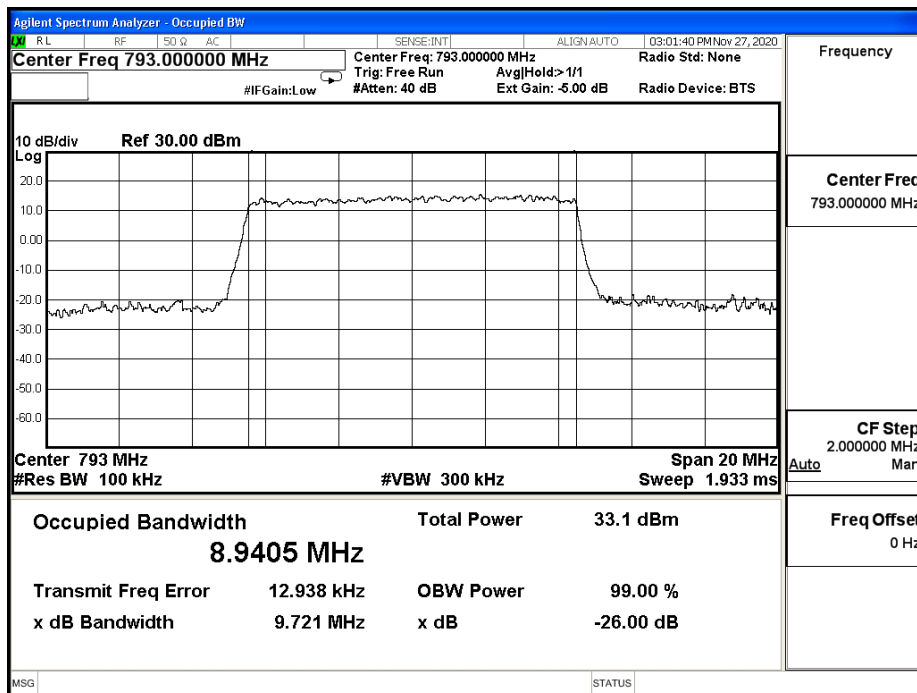

LTE_B14_CH23330_10M_16-QAM_50RB0

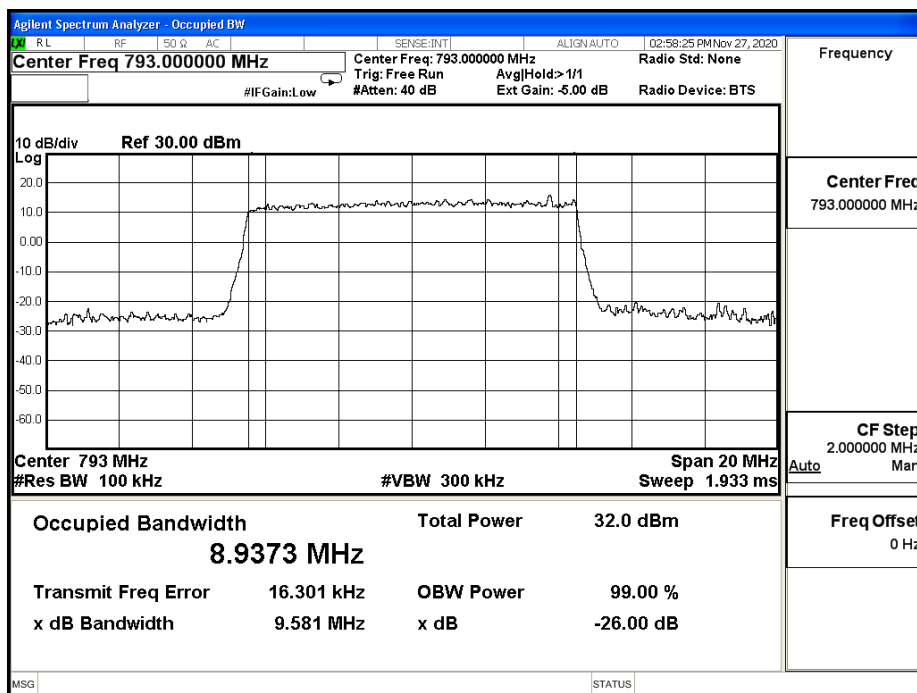

LTE_B14_CH23330_10M_64-QAM_50RB0

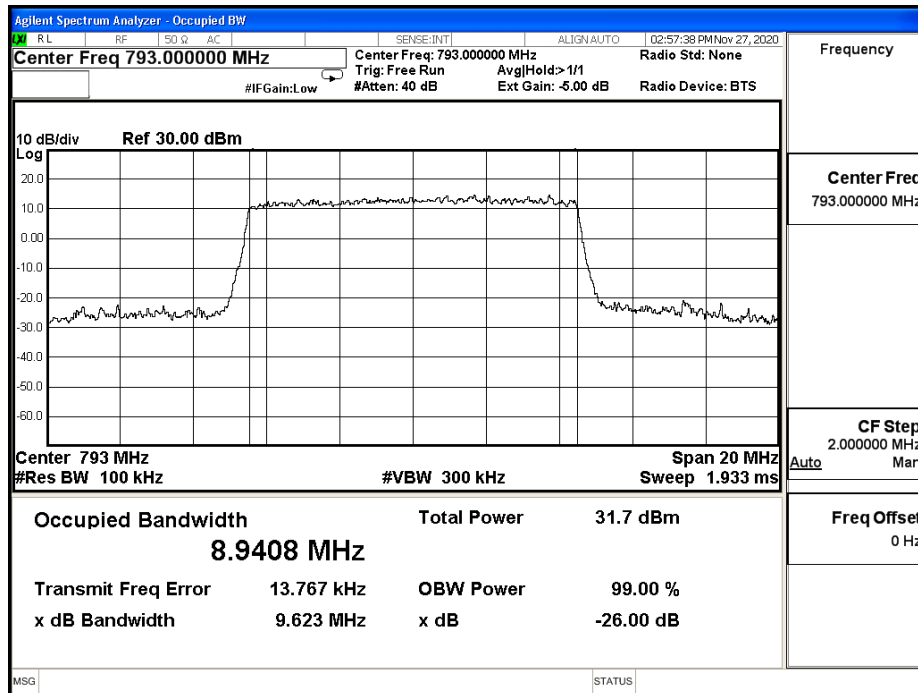

Note:

This report is prepared for Class II permissive change. The difference compared with original report no.: 2050962R-E3042110012-A is housing and software. The software changes as following:

- 1) Add LTE band 4, band 12, band 14, band 29 and close band 13 by software.
- 2) Close 5G FR2 band n261 by software.

According to above conditions, LTE band 12/ 14 and added EN-DC combination testing and Radiated Spurious Emissions (RSE) worst-case need to be performed and all data were verified to meet the requirements, and other test data refer to original report.

5. Peak To Average Ratio

5.1. Test Setup

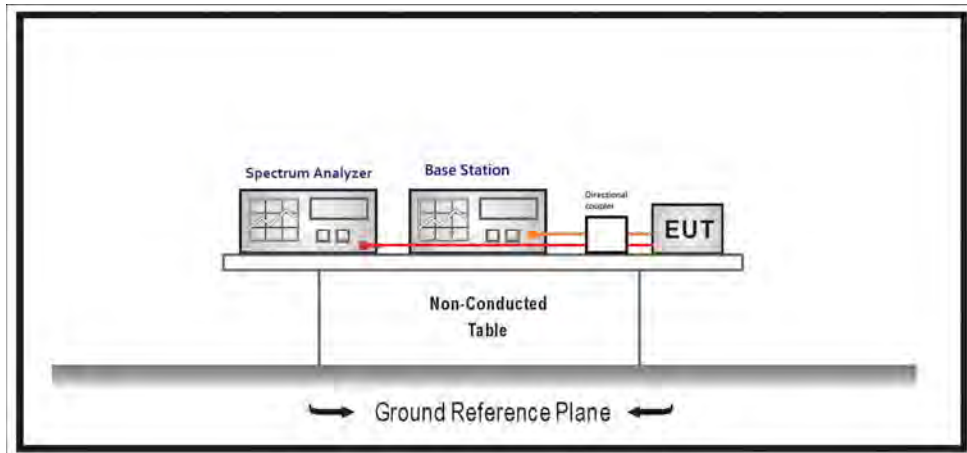

5.2. Test Procedure

1. Set resolution/measurement bandwidth \geq signal's occupied bandwidth.
2. Set the number of counts to a value that stabilizes the measured CCDF curve.
3. Record the maximum PAPR level associated with a probability of 0.1 %.

5.3. Test Method

KDB 971168 D01 Power Meas License Digital Systems v03 sub-clause 5.7.2
ANSI C63.26-2015 Sub-clause 5.2.3.4

5.4. Test Result

Product	5G CPE		
Test Item	Peak To Average Ratio		
Test Mode	Mode 1: ENDC 12A_n2		
Date of Test	2020/11/30	Test Site	SR12-H
Temperature (°C)	24	Humidity (%RH)	60

BW	Ch	Freq. (MHz)	Modulation	Peak (dBm)	Average (dBm)	PAPR (dB)
1.4M	23017	699.7	QPSK	25.78	22.11	3.65
			16-QAM	26.30	21.27	5.04
	23097	707.5	QPSK	26.72	22.70	3.91
			16-QAM	27.39	21.98	5.42
	23173	715.3	QPSK	26.52	22.76	3.68
			16-QAM	27.59	22.00	5.51
3M	23025	700.5	QPSK	25.59	21.97	3.59
			16-QAM	25.92	21.17	4.78
	23095	707.5	QPSK	25.27	21.86	3.48
			16-QAM	25.60	20.97	4.64
	23165	714.5	QPSK	25.50	21.84	3.65
			16-QAM	25.68	20.95	4.75
5M	23035	701.5	QPSK	25.34	21.76	3.62
			16-QAM	26.92	21.24	5.65
	23095	707.5	QPSK	24.96	21.52	3.39
			16-QAM	25.14	20.87	4.32
	23155	713.5	QPSK	25.11	21.37	3.74
			16-QAM	25.74	20.64	5.13
10M	23060	704	QPSK	23.90	20.00	3.88
			16-QAM	24.96	19.08	5.83
	23095	707.5	QPSK	23.03	19.67	3.36
			16-QAM	24.00	18.82	5.16
	23130	711	QPSK	22.95	19.62	3.33
			16-QAM	23.85	18.90	4.93

LTE_B12_CH23017_1.4M_QPSK_1RB0



Date: 30.NOV.2020 13:04:42

LTE_B12_CH23017_1.4M_16-QAM_1RB0

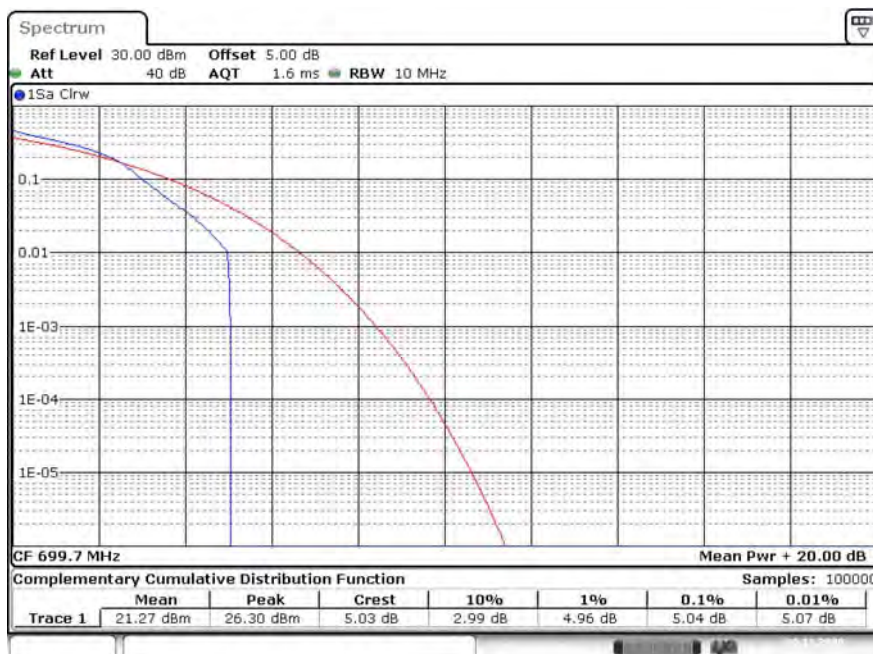

Date: 30.NOV.2020 13:05:05

LTE_B12_CH23095_1.4M__QPSK_1RB0

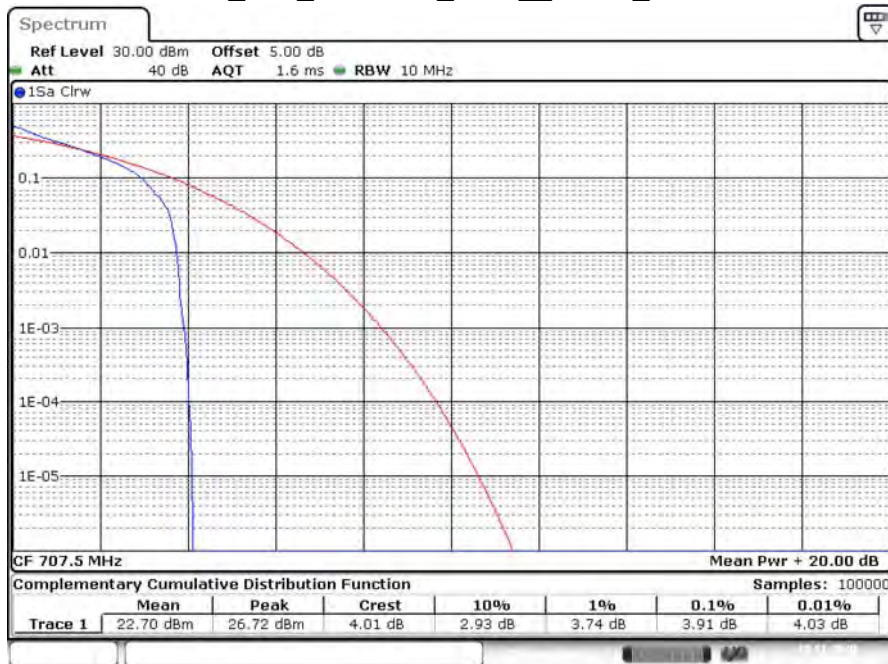

Date: 30.NOV.2020 13:05:51

LTE_B12_CH23095_1.4M_16-QAM_1RB0



Date: 30.NOV.2020 13:05:30

LTE_B12_CH23173_1.4M_QPSK_1RB5



Date: 30.NOV.2020 13:06:14

LTE_B12_CH23173_1.4M_16-QAM_1RB5

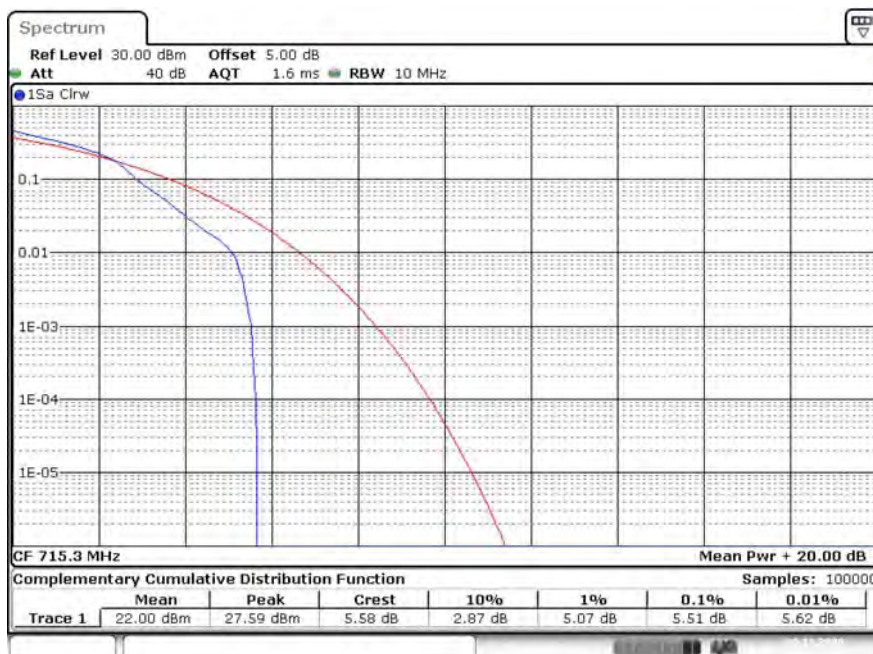

Date: 30.NOV.2020 13:06:35

LTE_B12_CH23025_3M_QPSK_1RB0



Date: 30.NOV.2020 13:39:39

LTE_B12_CH23025_3M_16-QAM_1RB0

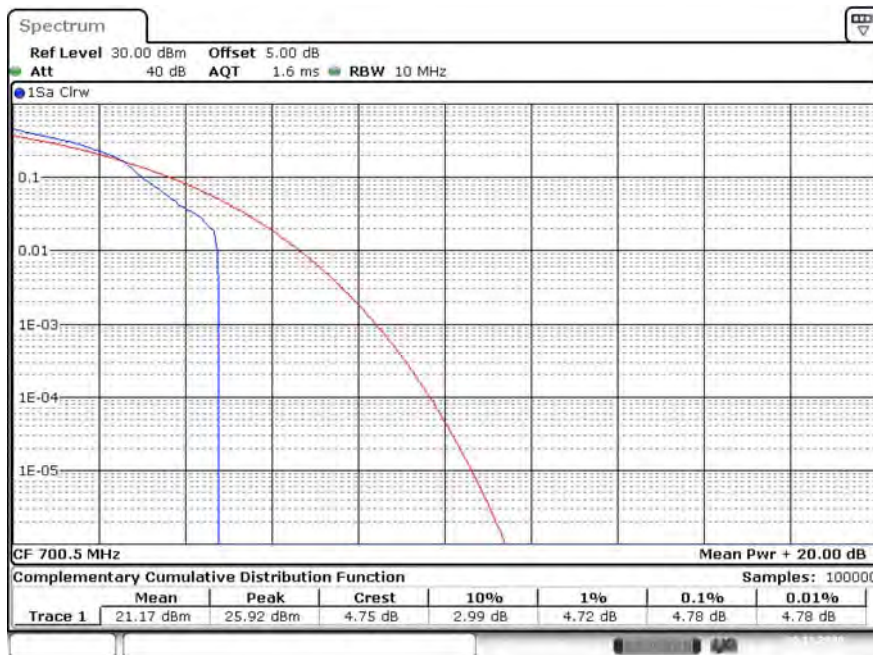

Date: 30.NOV.2020 13:40:13

LTE_B12_CH23095_3M_QPSK_1RB0

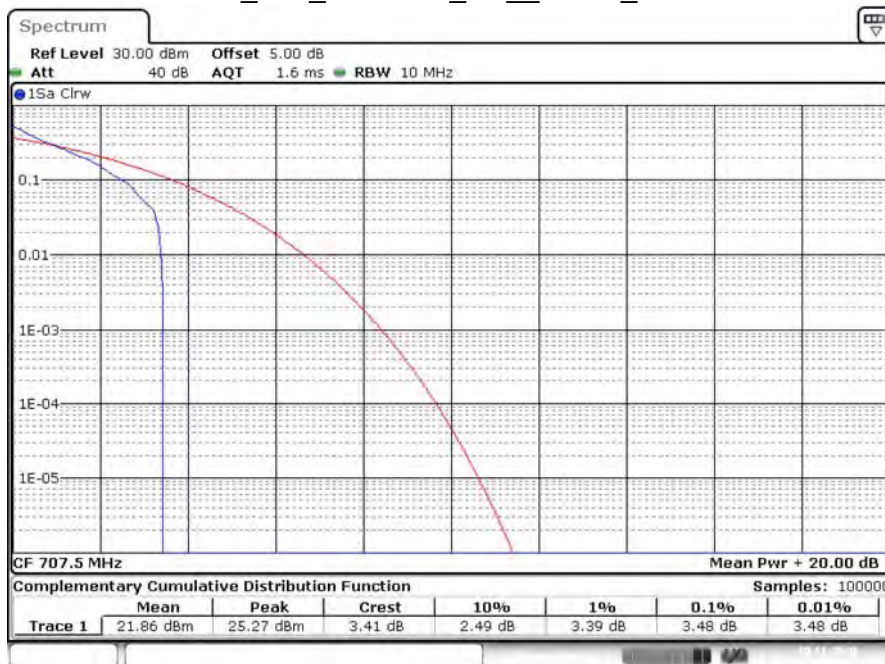

Date: 30.NOV.2020 13:41:22

LTE_B12_CH23095_3M_16-QAM_1RB0

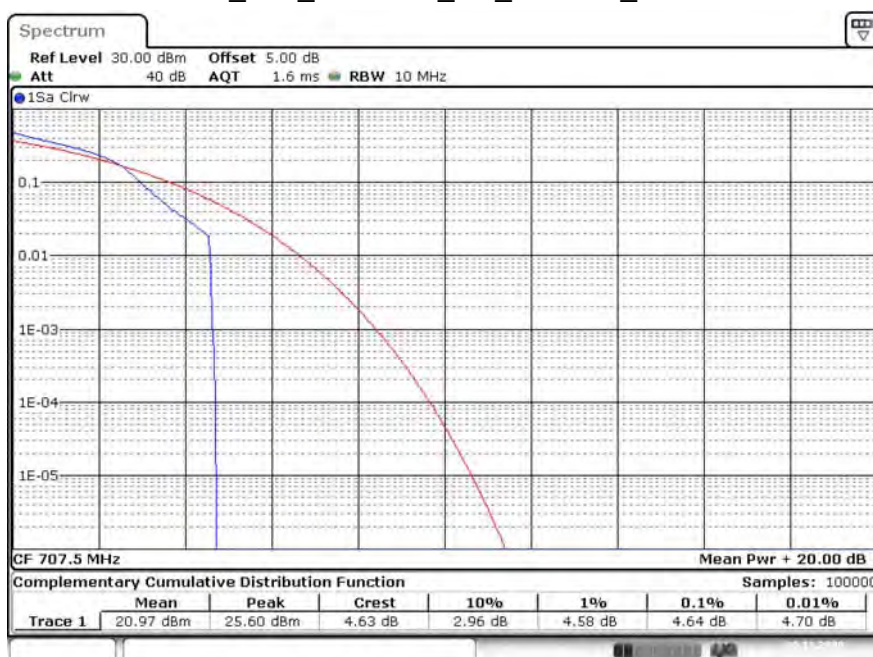

Date: 30.NOV.2020 13:41:03

LTE_B12_CH23165_3M_QPSK_1RB14

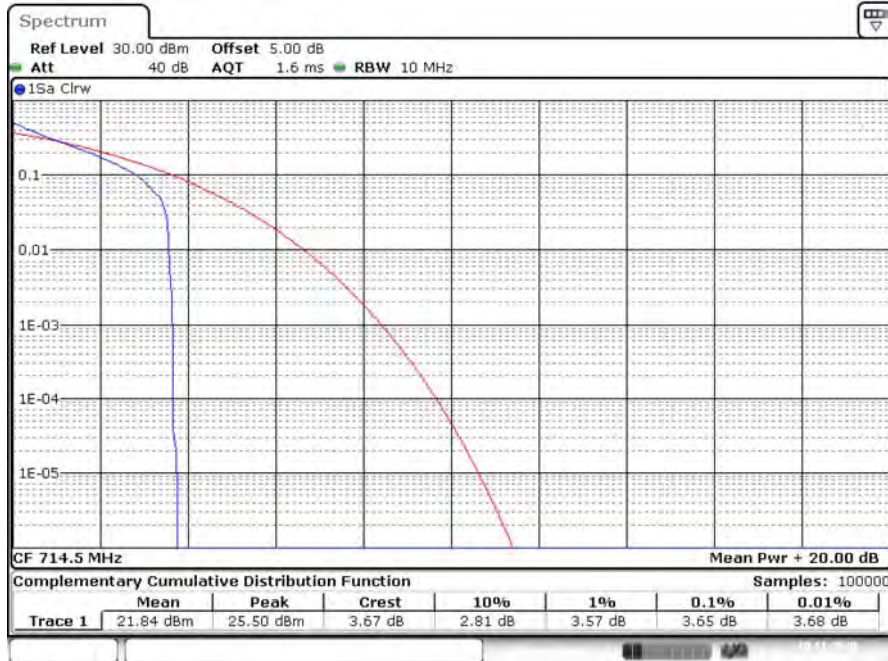

Date: 30.NOV.2020 13:41:47

LTE_B12_CH23165_3M_16-QAM_1RB14



Date: 30.NOV.2020 13:42:05

LTE_B12_CH23035_5M_QPSK_1RB0



Date: 30.NOV.2020 13:43:15

LTE_B12_CH23035_5M_16-QAM_1RB0

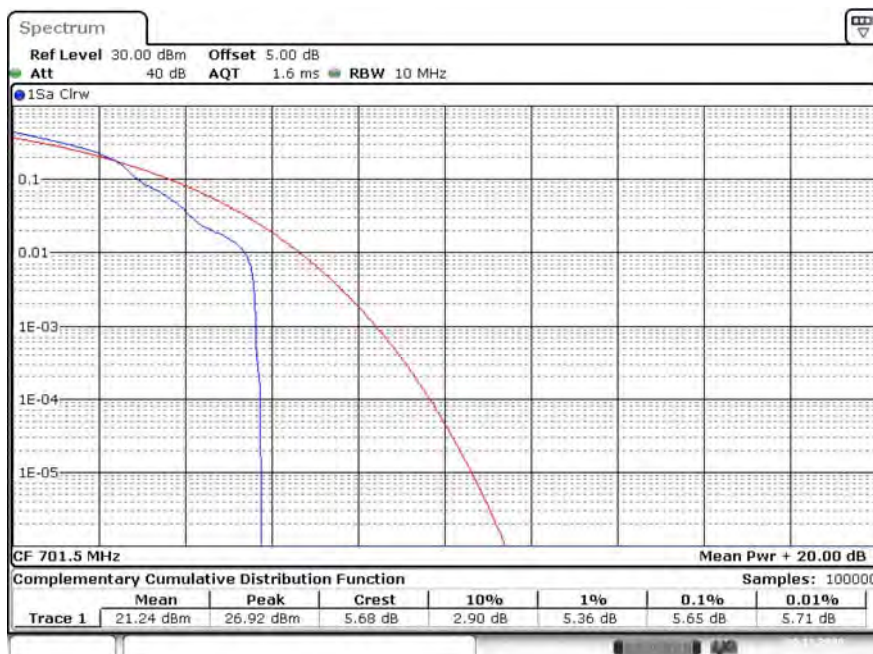

Date: 30.NOV.2020 13:43:31

LTE_B12_CH23095_5M_QPSK_1RB0

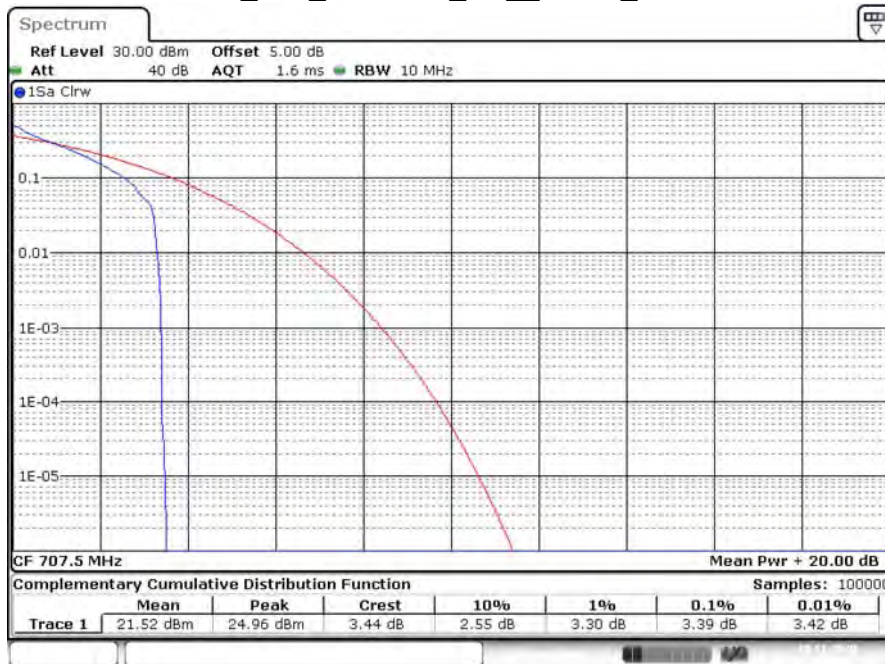

Date: 30.NOV.2020 13:44:12

LTE_B12_CH23095_5M_16-QAM_1RB0



Date: 30.NOV.2020 13:43:52

LTE_B12_CH23155_5M_QPSK_1RB24

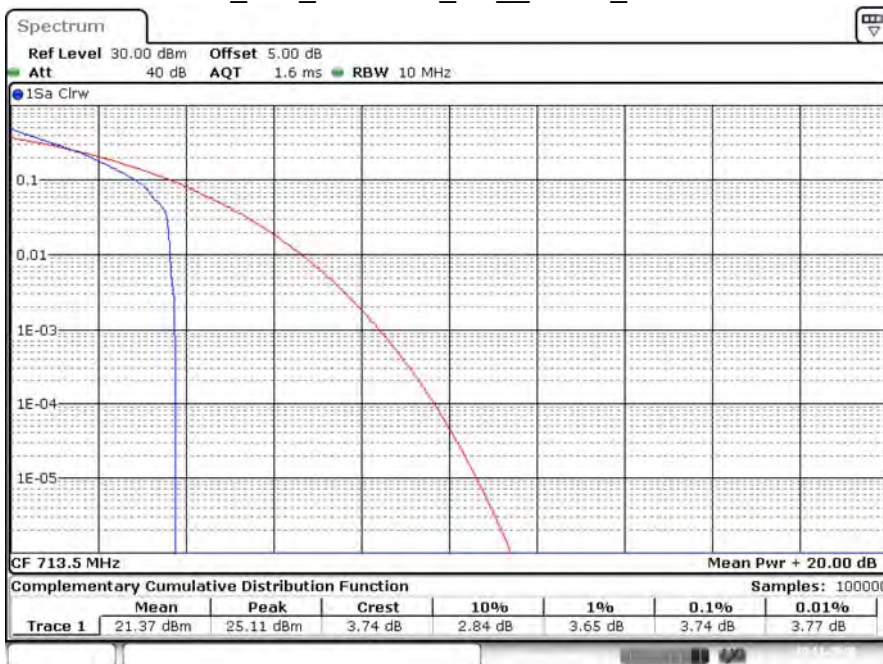

Date: 30.NOV.2020 13:44:31

LTE_B12_CH23155_5M_16-QAM_1RB24

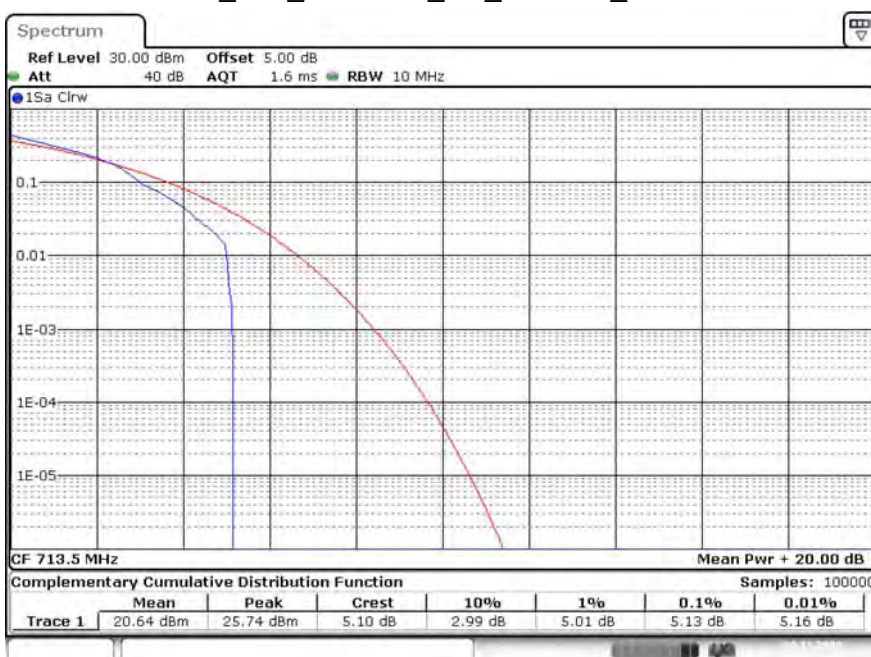

Date: 30.NOV.2020 13:44:45

LTE_B12_CH23060_10M_QPSK_1RB0

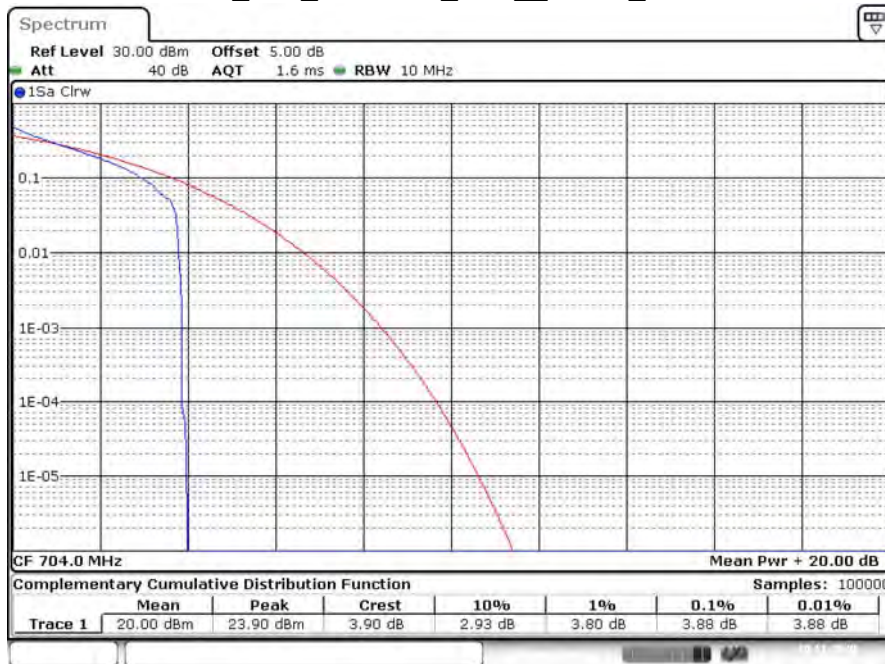

Date: 30.NOV.2020 13:45:48

LTE_B12_CH23060_10M_16-QAM_1RB0

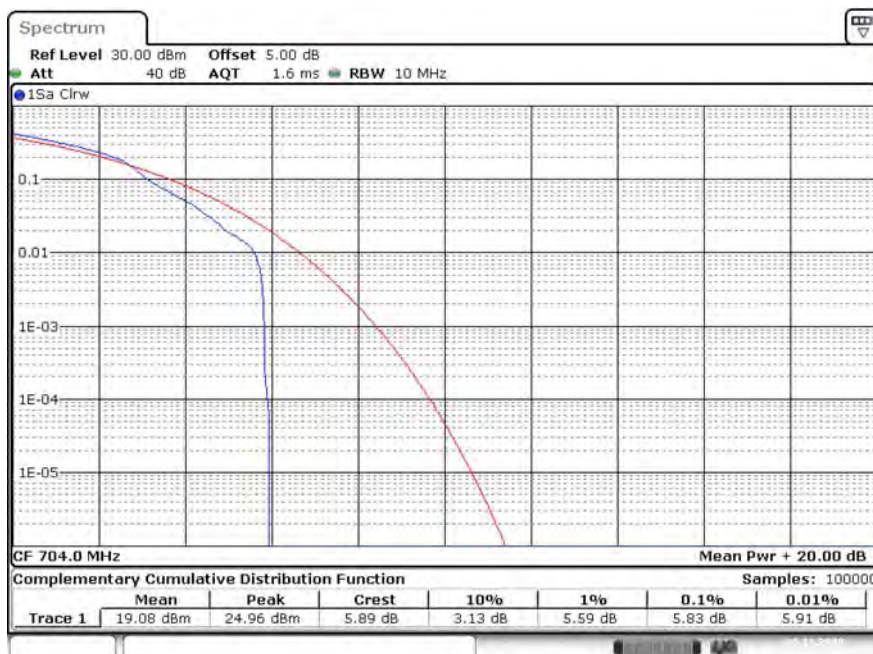

Date: 30.NOV.2020 13:46:10

LTE_B12_CH23095_10M_QPSK_1RB0



Date: 30.NOV.2020 13:46:52

LTE_B12_CH23095_10M_16-QAM_1RB0

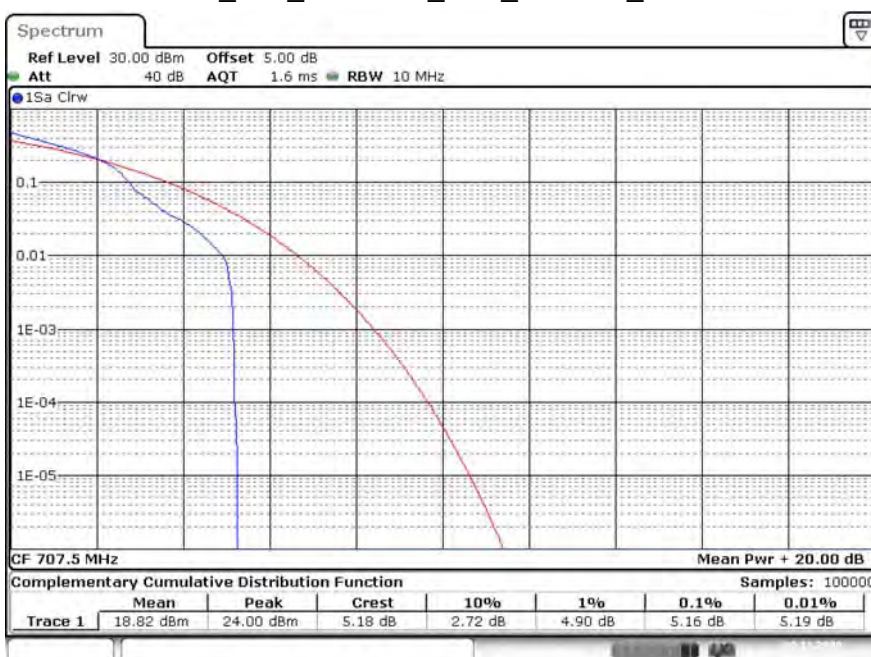

Date: 30.NOV.2020 13:46:35

LTE_B12_CH23130_10M_QPSK_1RB49

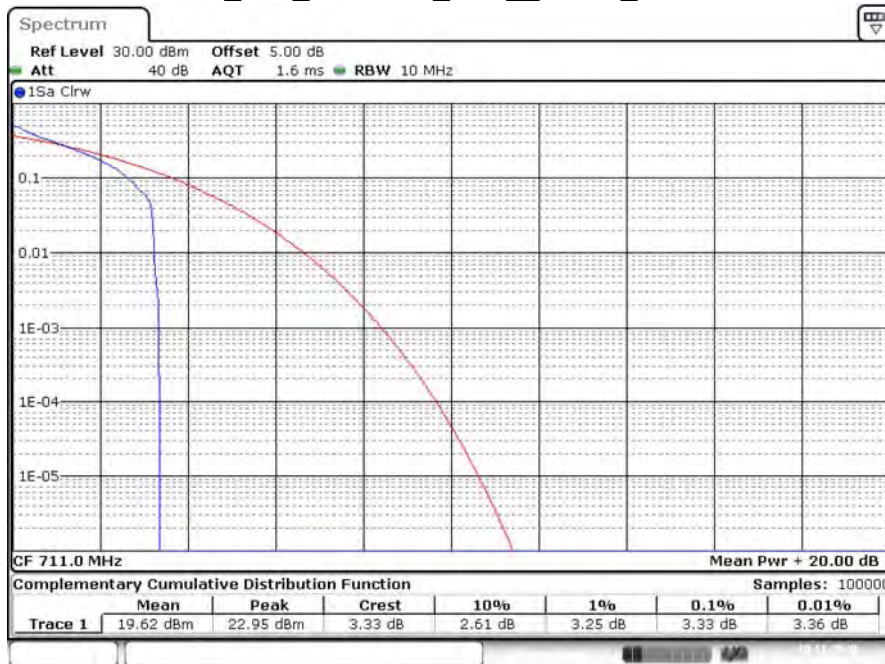

Date: 30.NOV.2020 13:47:13

LTE_B12_CH23130_10M_16-QAM_1RB49

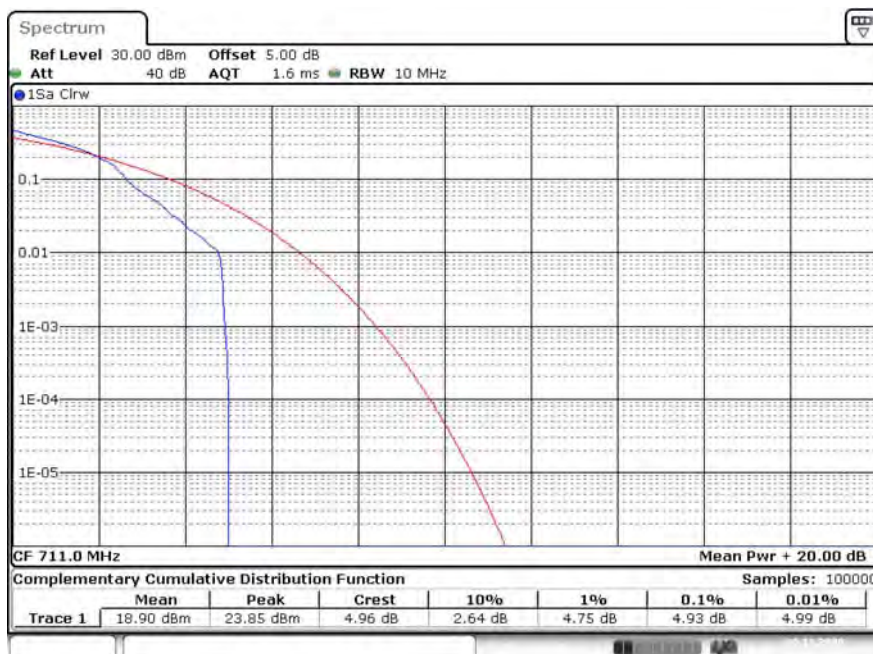

Date: 30.NOV.2020 13:47:30

Product	5G CPE		
Test Item	Peak To Average Ratio		
Test Mode	Mode 2: ENDC 14A_n66		
Date of Test	2020/11/30	Test Site	SR12-H
Temperature (°C)	24	Humidity (%RH)	60

BW	Ch	Freq. (MHz)	Modulation	Peak (dBm)	Average (dBm)	PAPR (dB)
5M	23305	790.5	QPSK	26.58	22.97	3.59
			16-QAM	27.62	22.32	5.25
	23330	793	QPSK	26.86	23.02	3.80
			16-QAM	27.76	22.28	5.39
	23355	795.5	QPSK	26.77	23.03	3.71
			16-QAM	27.29	22.34	4.96
10M	23330	793	QPSK	24.91	21.39	3.54
			16-QAM	26.08	20.97	5.07

LTE_B14_CH23305_5M_QPSK_1RB0



Date: 30.NOV.2020 13:52:52

LTE_B14_CH23305_5M_16-QAM_1RB0

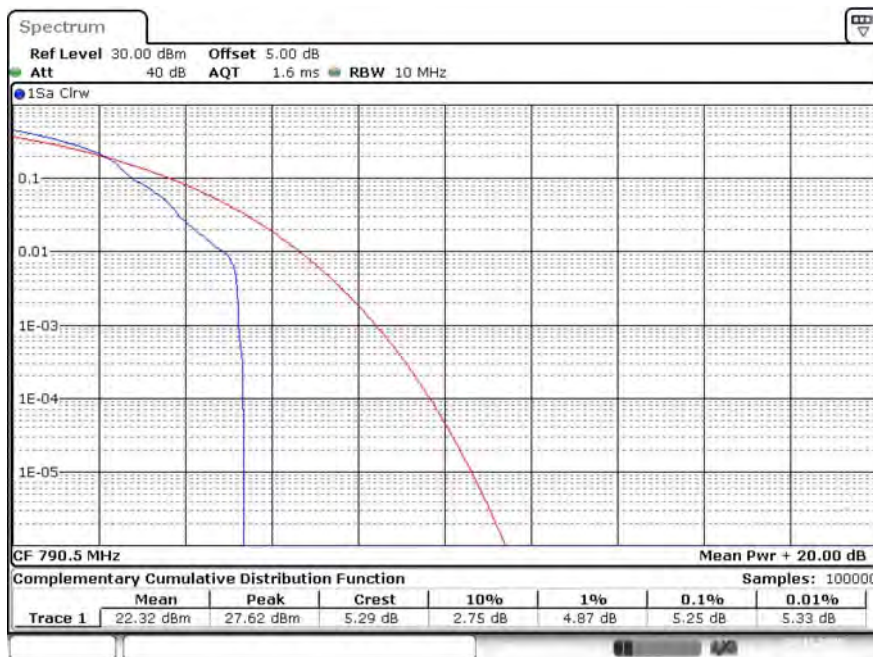

Date: 30.NOV.2020 13:53:03

LTE_B14_CH23330_5M_QPSK_1RB0



Date: 30.NOV.2020 13:52:13

LTE_B14_CH23330_5M_16-QAM_1RB0

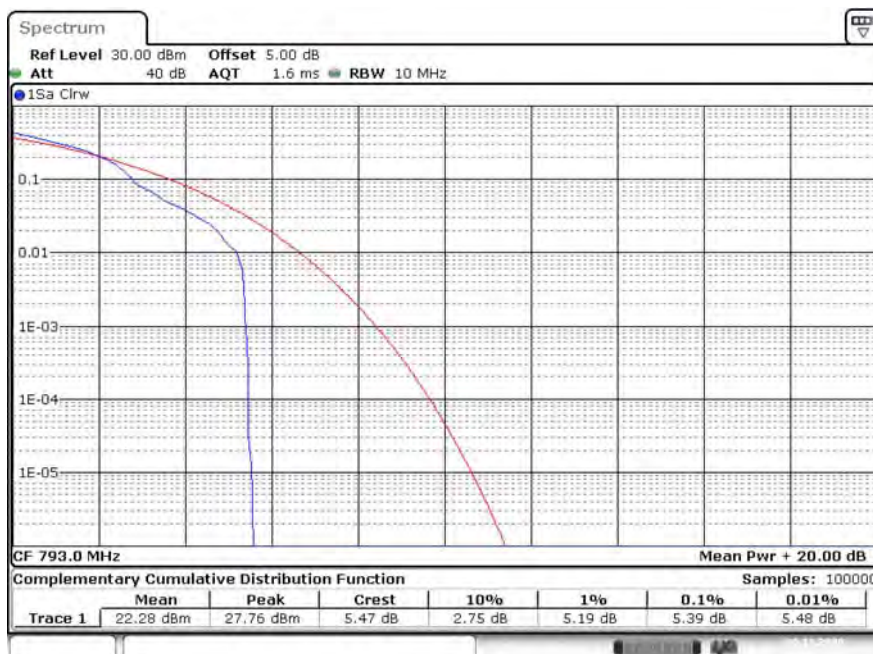

Date: 30.NOV.2020 13:51:25

LTE_B14_CH23355_5M_QPSK_1RB24

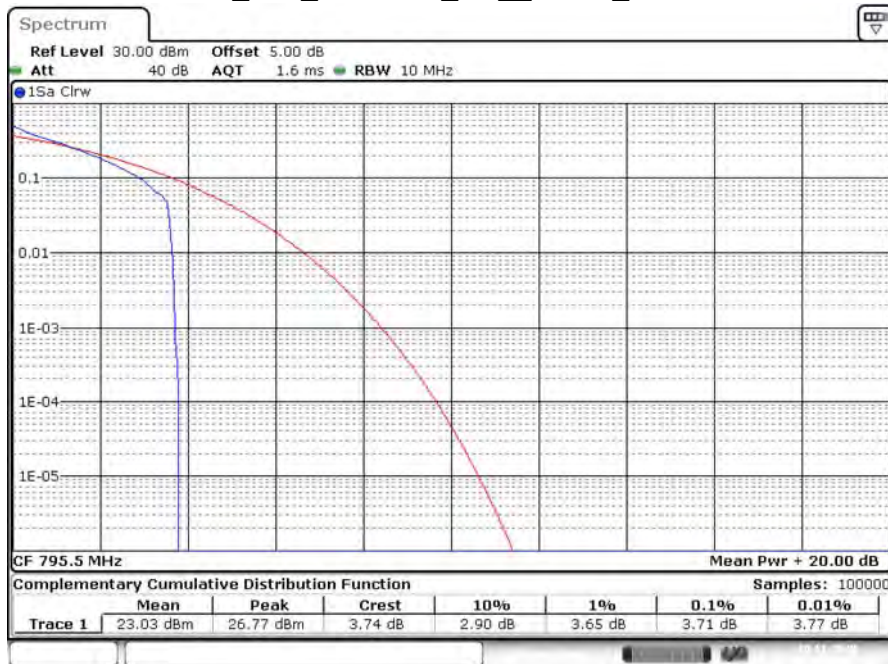

Date: 30.NOV.2020 13:53:40

LTE_B14_CH23355_5M_16-QAM_1RB24

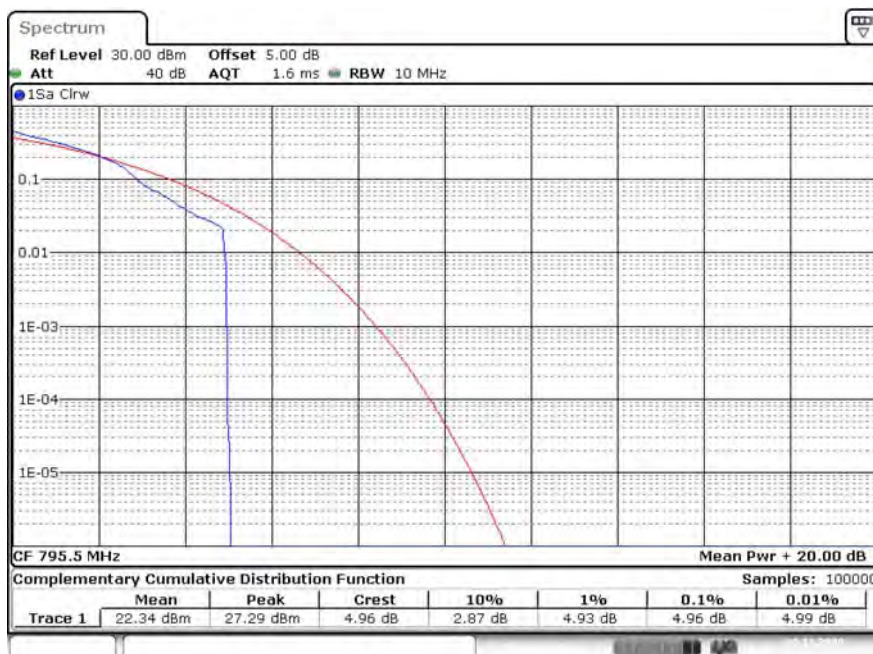

Date: 30.NOV.2020 13:53:25

LTE_B14_CH23330_10M_QPSK_1RB0

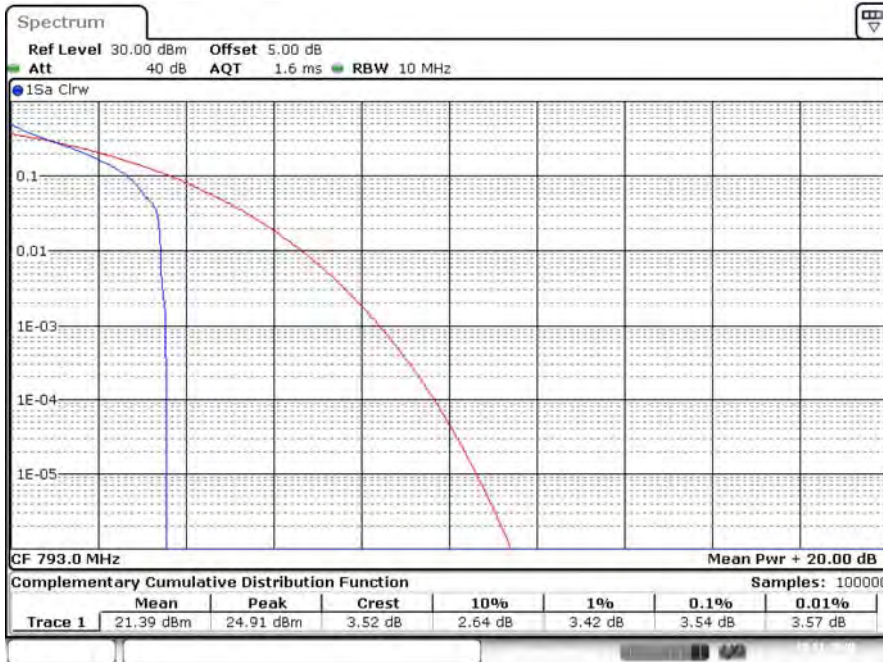

Date: 30.NOV.2020 13:48:40

LTE_B14_CH23330_10M_16-QAM_1RB0

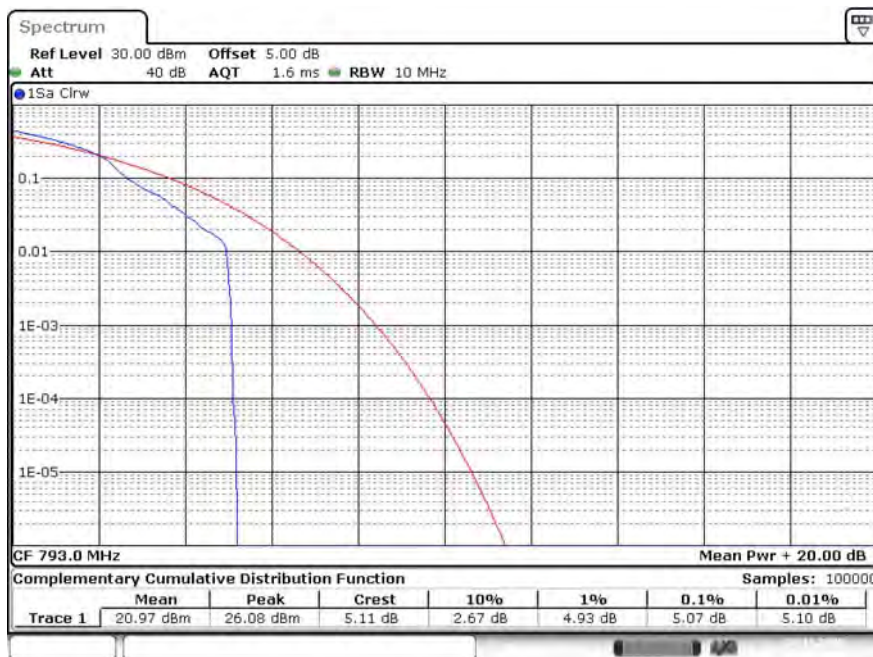

Date: 30.NOV.2020 13:48:26

Note:

This report is prepared for Class II permissive change. The difference compared with original report no.: 2050962R-E3042110012-A is housing and software. The software changes as following:

- 1) Add LTE band 4, band 12, band 14, band 29 and close band 13 by software.
- 2) Close 5G FR2 band n261 by software.

According to above conditions, LTE band 12/ 14 and added EN-DC combination testing and Radiated Spurious Emissions (RSE) worst-case need to be performed and all data were verified to meet the requirements, and other test data refer to original report.

6. Spurious Emissions

6.1. Test Setup

Conducted Spurious Measurement: below 1GHz

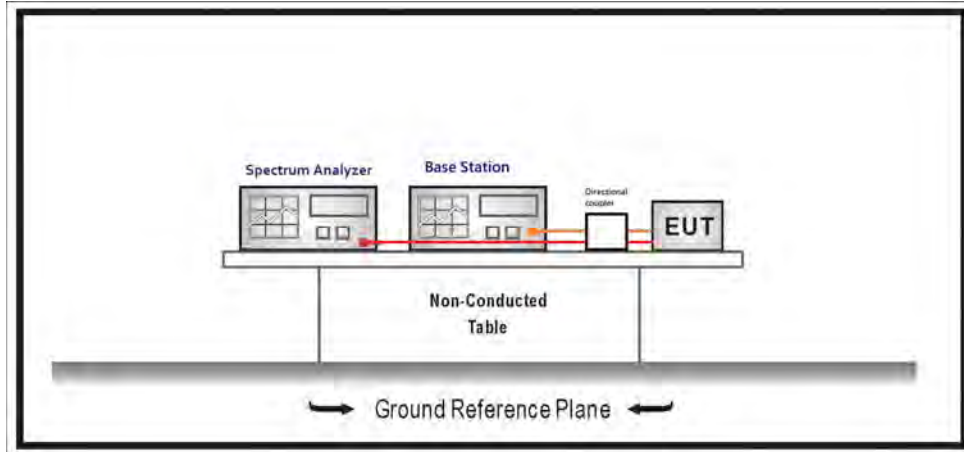

Radiated Spurious Measurement: below 1GHz

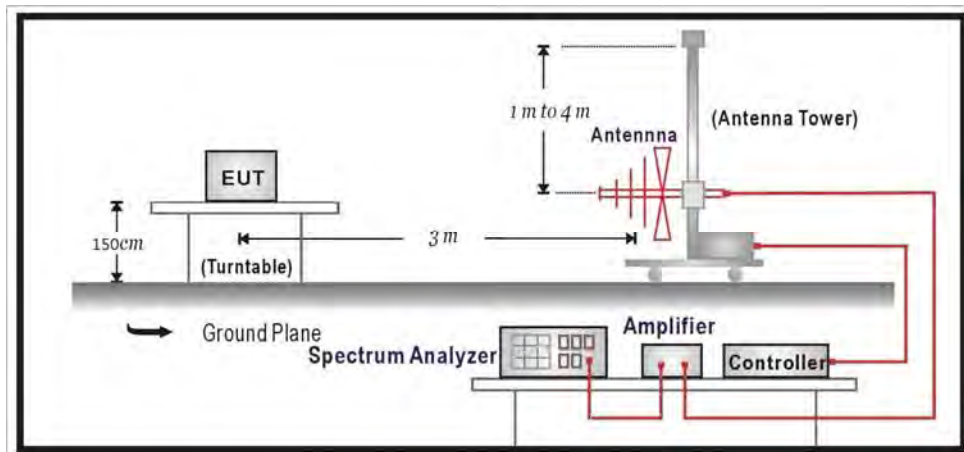

Radiated Spurious Measurement: above 1GHz

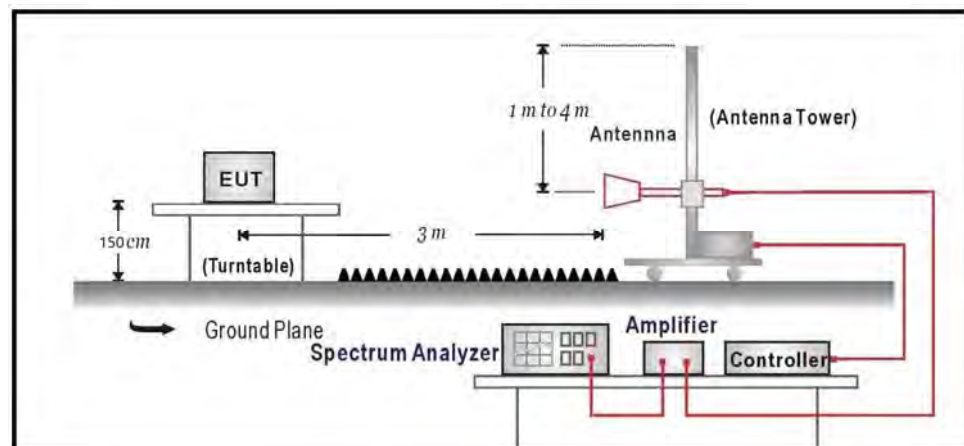

6.2. Test Procedure

Conducted Spurious Measurement:

- a) Place the EUT on a bench and set it in transmitting mode.
- b) Connect a low loss RF cable from the antenna port to a spectrum analyzer and CMW500 by a Directional Couple.
- c) EUT Communicate with CMW500, then select a channel for testing.
- d) Add a correction factor to the display of spectrum, and then test.
- e) The resolution bandwidth of the spectrum analyzer was set at 1 MHz, sufficient scans were taken to show the out of band Emission if any up to 10th harmonic.

Radiated Spurious Measurement:

- a) The EUT was placed on a rotatable wooden table with 1.5 meter above ground.
- b) The EUT was set 3 meters from the receiving antenna, which was mounted on the antenna tower.
- c) The table was rotated 360 degrees to determine the position of the highest spurious emission.
- d) The height of the receiving antenna is varied between one meter and four meters to search the maximum spurious emission for both horizontal and vertical polarizations.
- e) Make the measurement with the spectrum analyzer's RBW = 1MHz, VBW = 1MHz, Sweep 500ms, Taking the record of maximum spurious emission.
- f) A horn antenna was substituted in place of the EUT and was driven by a signal generator.
- g) Tune the output power of signal generator to the same emission level with EUT maximum spurious emission.
- h) Taking the record of output power at antenna port.
- i) Repeat step 7 to step 8 for another polarization.
- j) $EIRP = SG - \text{Cable loss} + \text{Antenna Gain}$

6.3. Test Method

Conducted Spurious Measurement:

KDB 971168 D01 Power Meas License Digital Systems v03 sub-clause6.1
ANSI C63.26-2015 Sub-clause 5.7

Radiated Spurious Measurement:

KDB 971168 D01 Power Meas License Digital Systems v03 sub-clause5.8
ANSI C63.26-2015 Sub-clause 5.5.3.2

6.4. Test Result Conducted Spurious Emission

Product	5G CPE		
Test Item	Spurious Emissions		
Test Mode	Mode 1: ENDC 12A_n2		
Date of Test	2020/11/25	Test Site	SR12-H
Temperature (°C)	23	Humidity (%RH)	63

B12_CH23017_1.4M_1RB0_QPSK_Above 1G

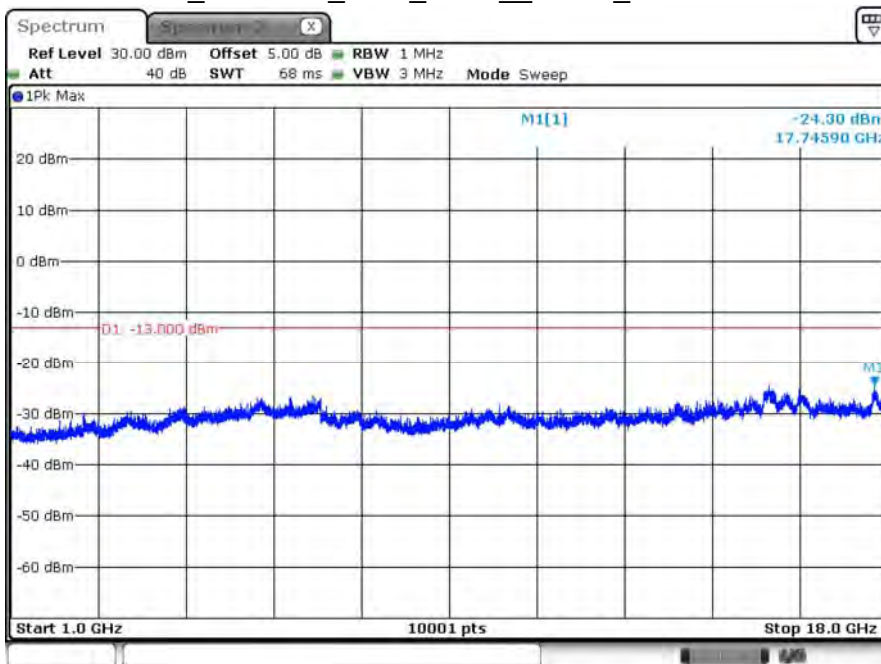

Date: 25 NOV.2020 03:23:43

B12_CH23017_1.4M_1RB0_QPSK_Below 1G

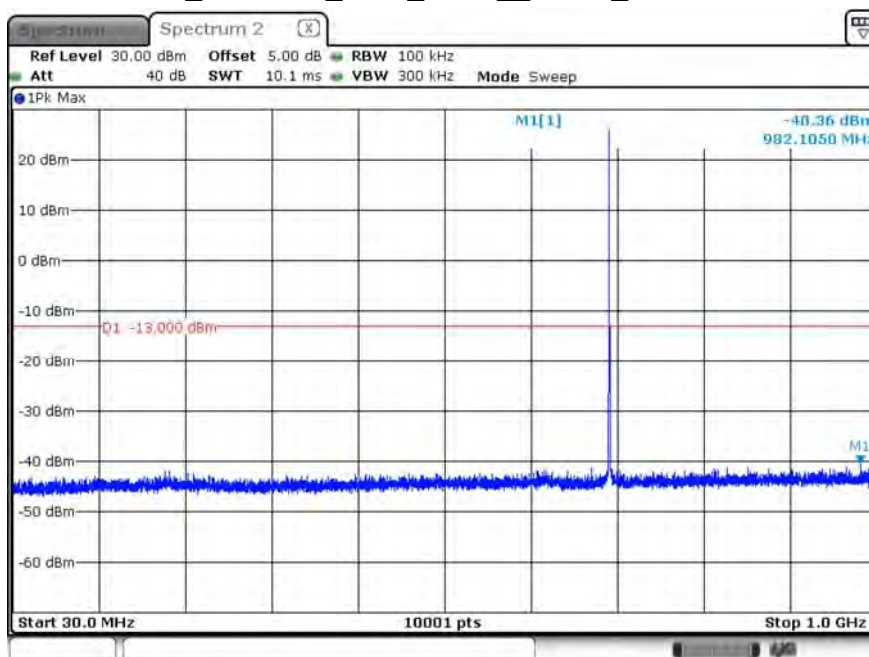

Date: 25 NOV.2020 03:24:59

B12_CH23095_1.4M_1RB0__QPSK_Above 1G

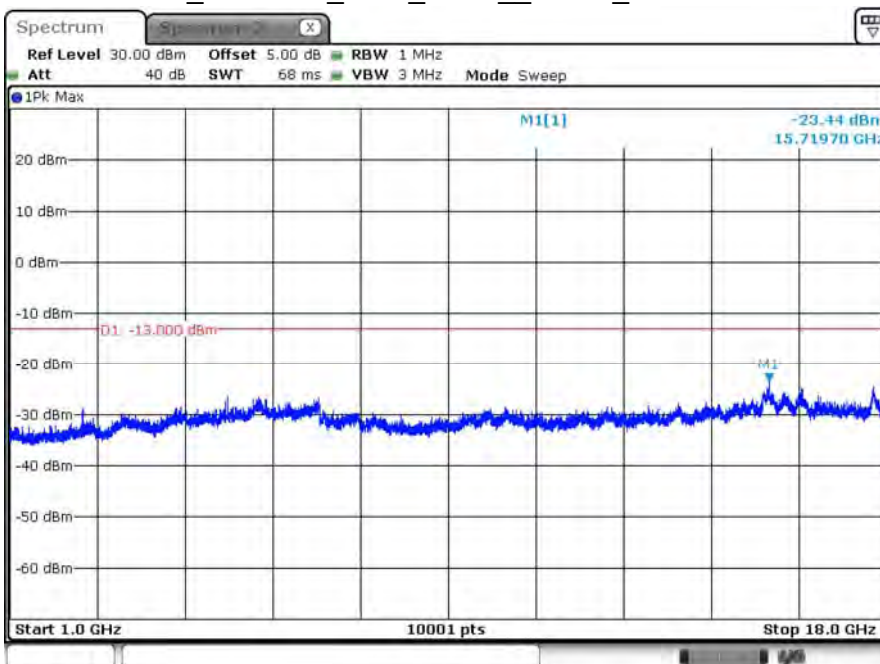

Date: 25 NOV.2020 03:22:32

B12_CH23095_1.4M_1RB0__QPSK_Below 1G

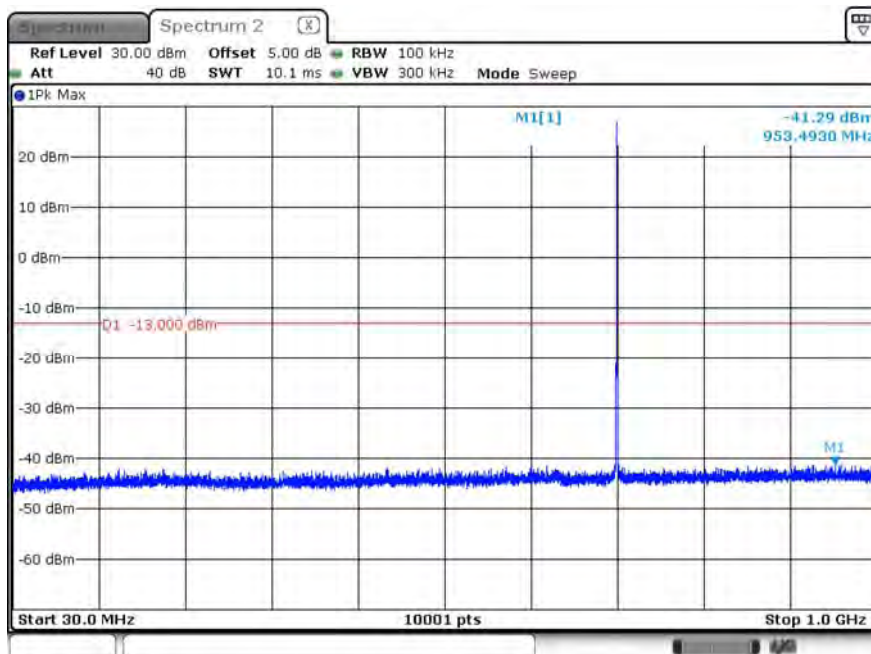

Date: 25 NOV.2020 03:19:32

B12_CH23173_1.4M_1RB0__QPSK_Above 1G

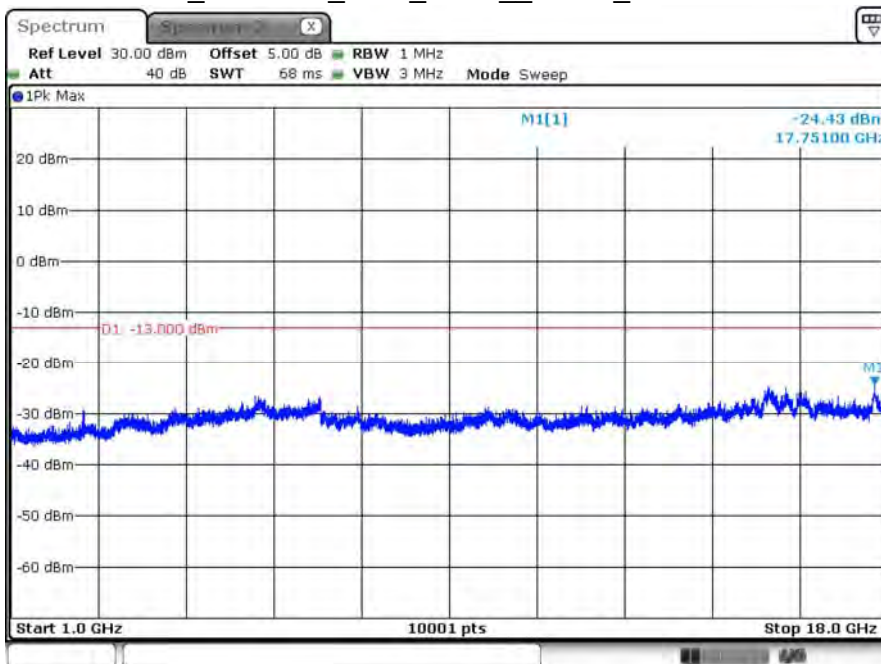

Date: 25 NOV.2020 03:32:48

B12_CH23173_1.4M_1RB0__QPSK_Below 1G

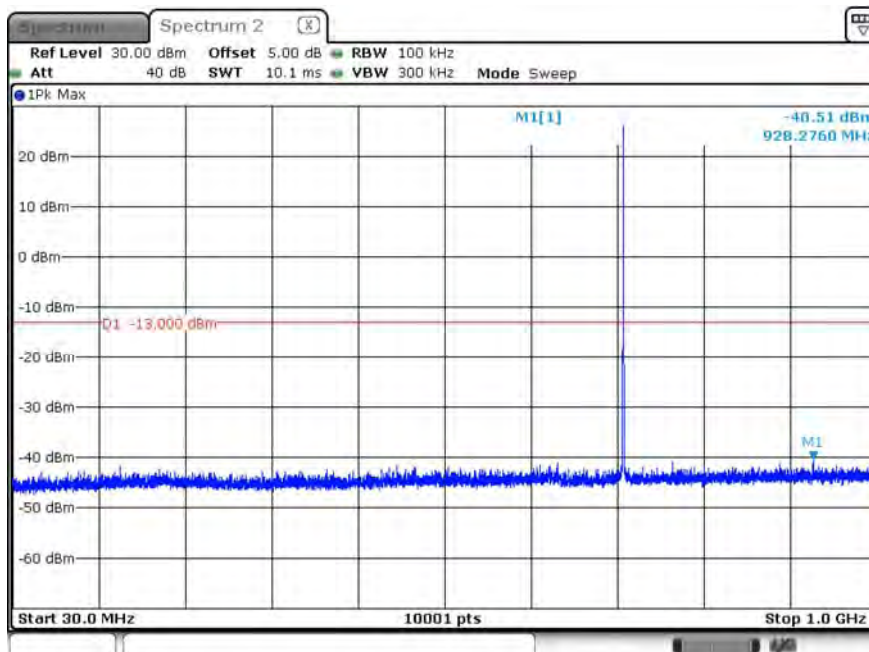

Date: 25 NOV.2020 03:32:09

B12_CH23025_3M_1RB0_QPSK_Above 1G

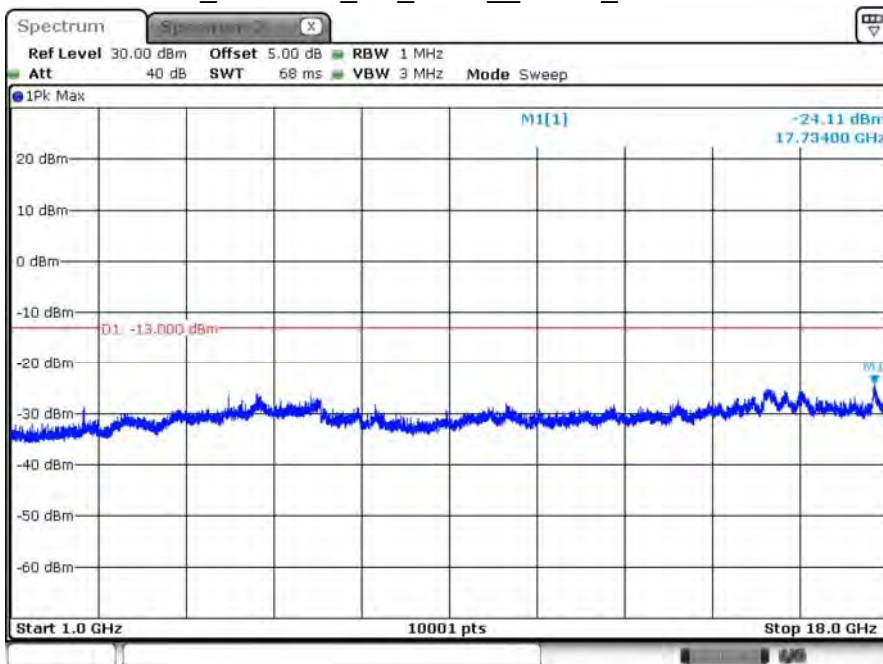

Date: 25 NOV.2020 03:11:42

B12_CH23025_3M_1RB0_QPSK_Below 1G

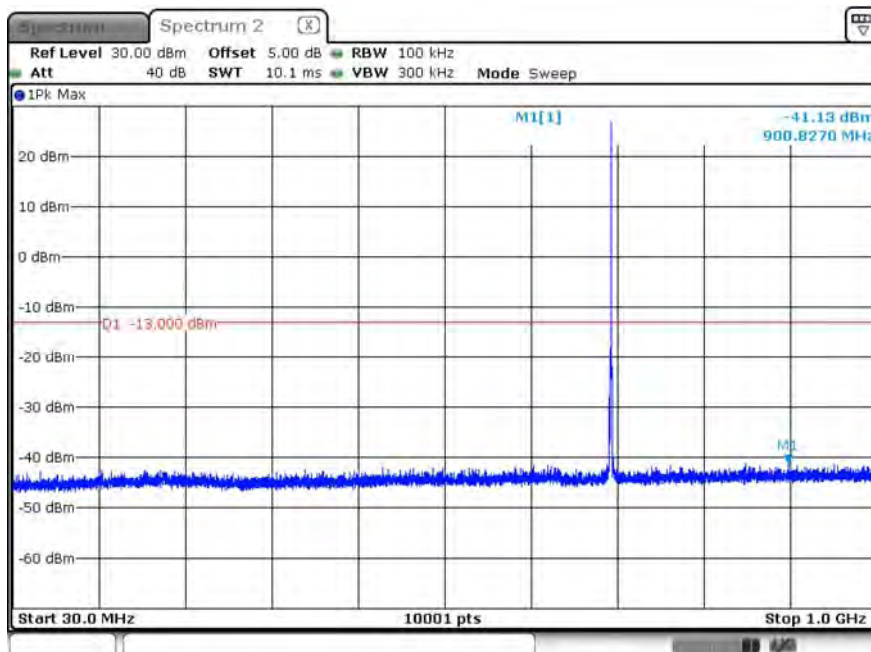

Date: 25 NOV.2020 03:10:31

B12_CH23095_3M_1RB0_QPSK_Above 1G

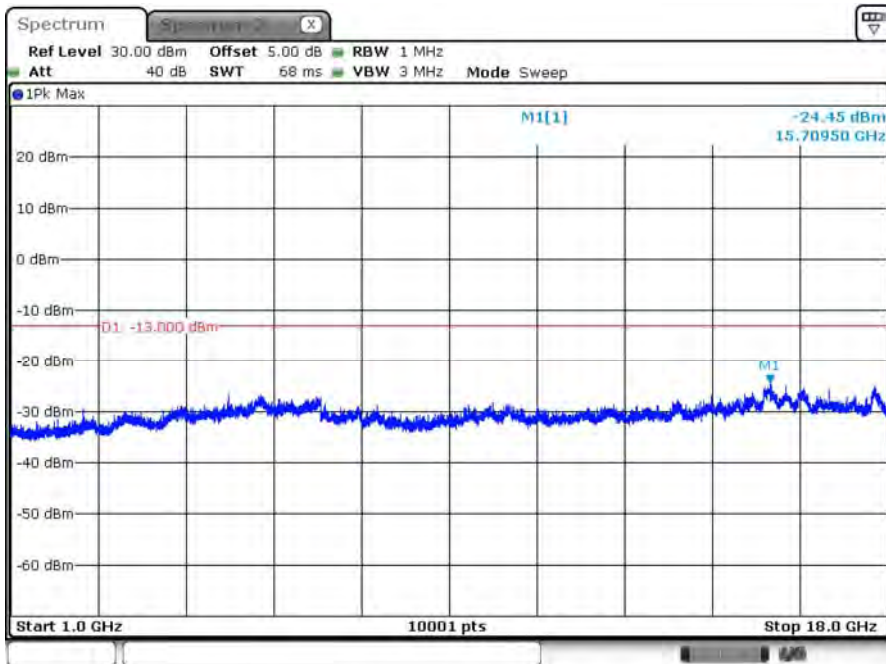

Date: 25 NOV.2020 03:07:22

B12_CH23095_3M_1RB0_QPSK_Below 1G

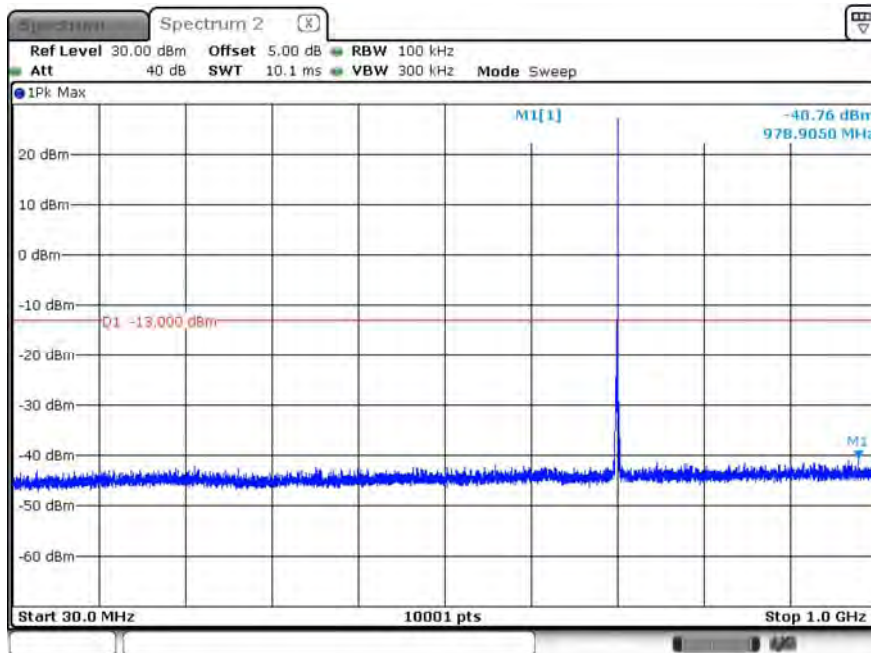

Date: 25 NOV.2020 03:08:31

B12_CH23165_3M_1RB0__QPSK_Above 1G

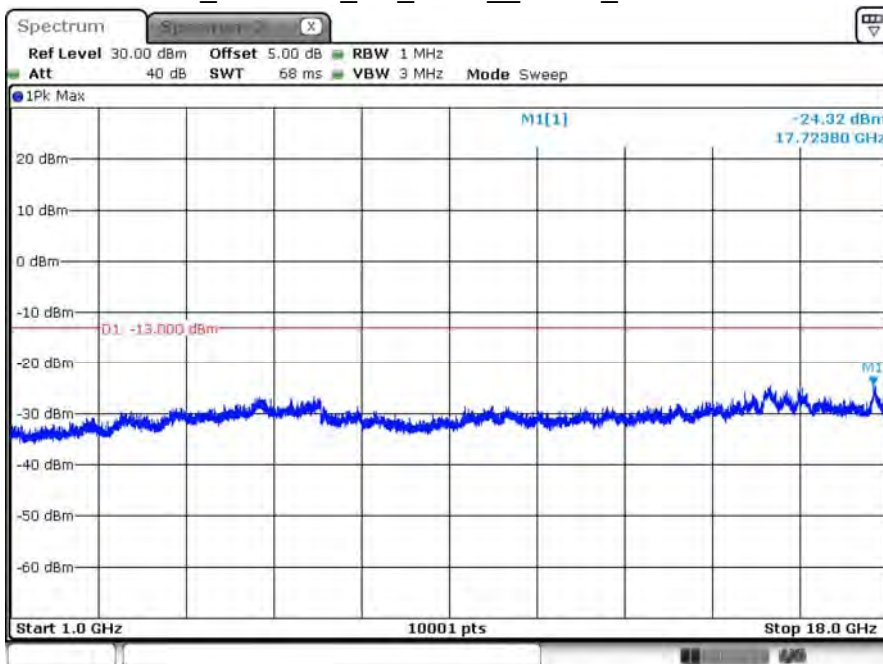

Date: 25 NOV.2020 03:14:18

B12_CH23165_3M_1RB0__QPSK_Below 1G

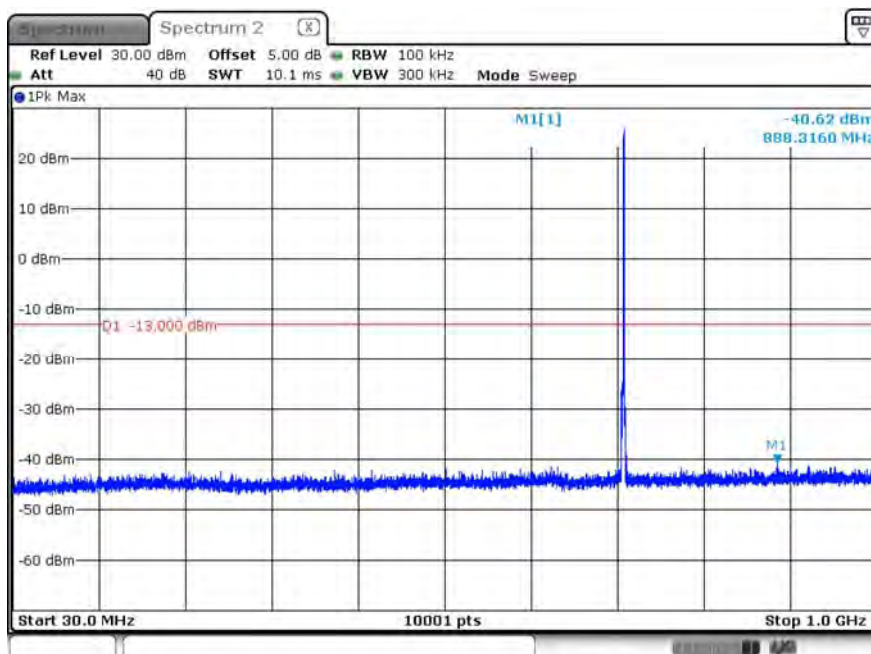

Date: 25 NOV.2020 03:16:50

B12_CH23035_5M_1RB0_QPSK_Above 1G

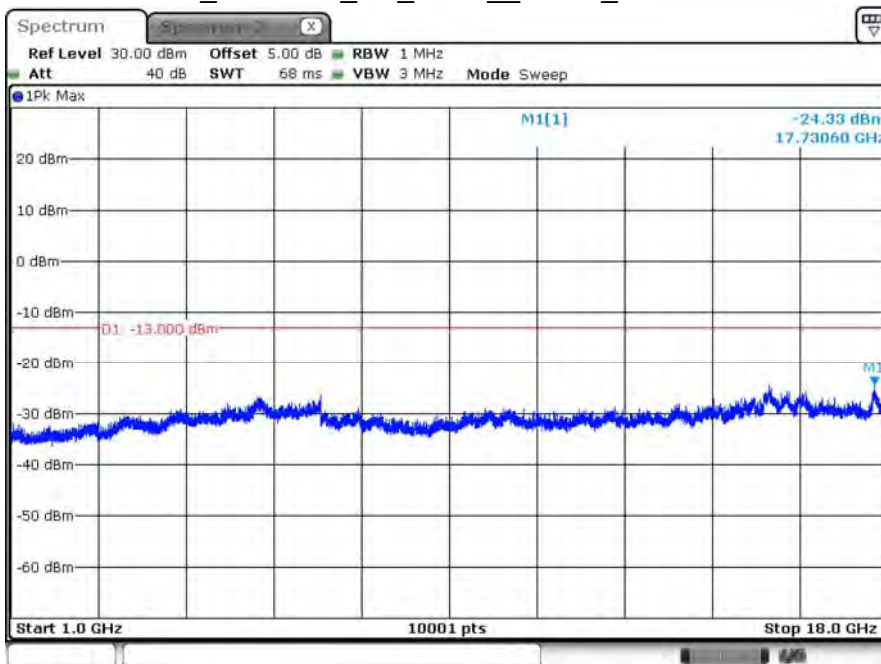

Date: 25 NOV.2020 02:54:51

B12_CH23035_5M_1RB0_QPSK_Below 1G

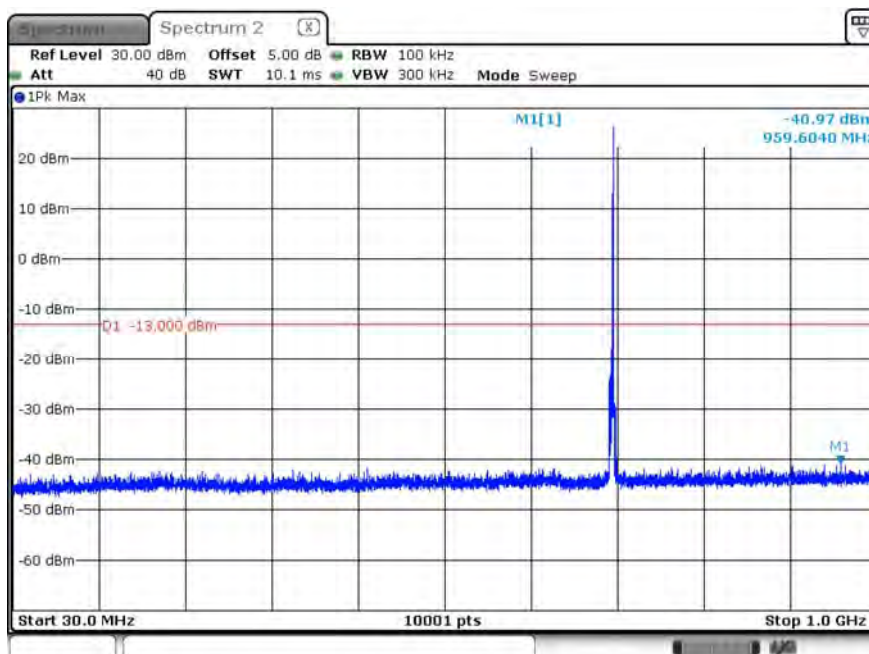

Date: 25 NOV.2020 02:55:47

B12_CH23095_5M_1RB0_QPSK_Above 1G

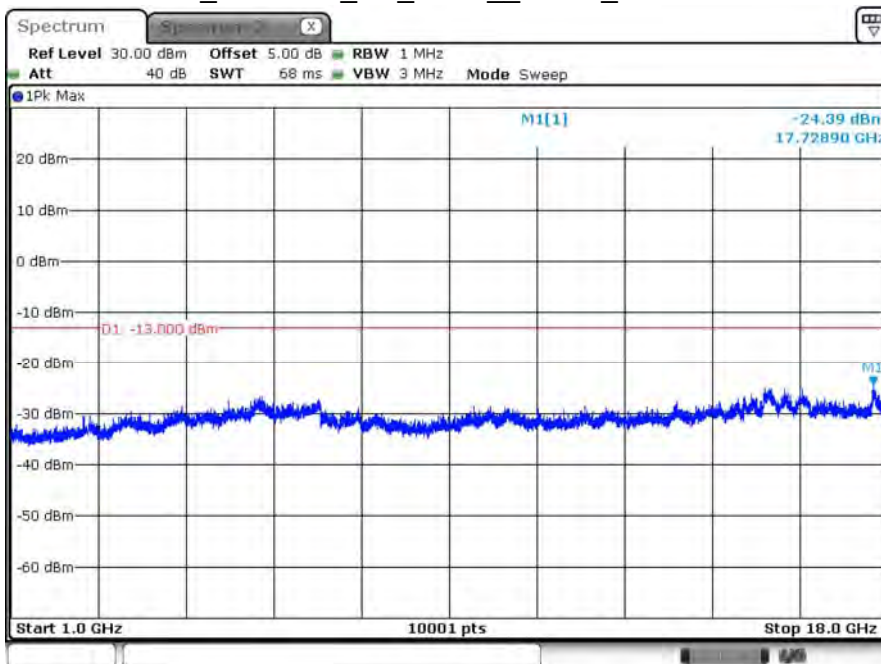

Date: 25 NOV.2020 02:53:50

B12_CH23095_5M_1RB0_QPSK_Below 1G

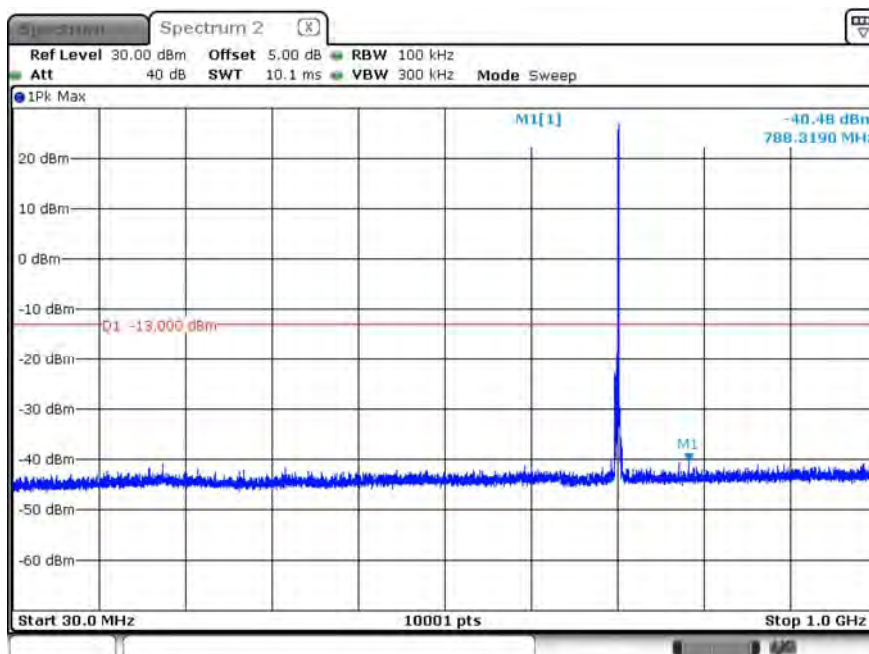

Date: 25 NOV.2020 02:51:53

B12_CH23155_5M_1RB0_QPSK_Above 1G

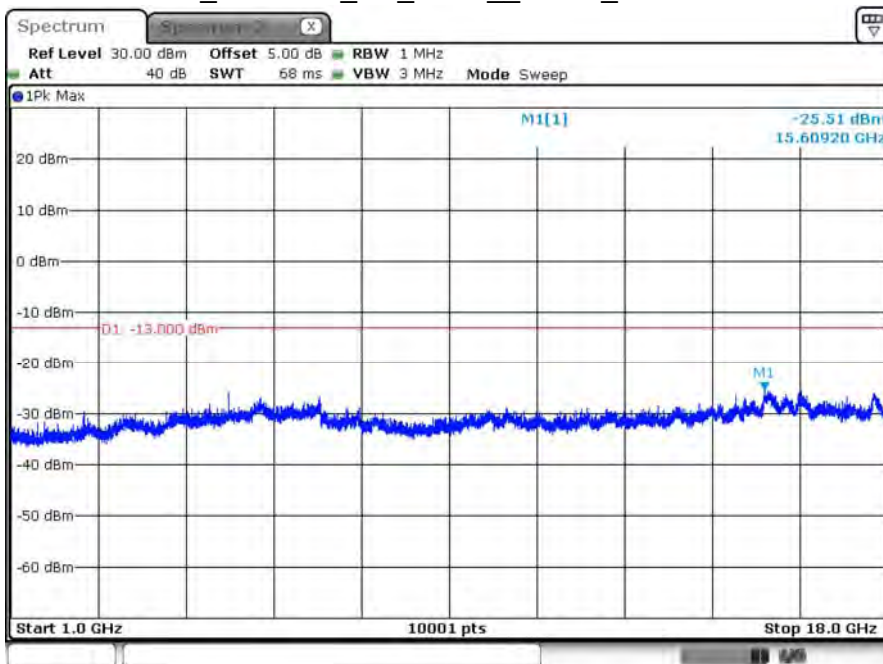

Date: 25 NOV.2020 02:57:39

B12_CH23155_5M_1RB0_QPSK_Below 1G

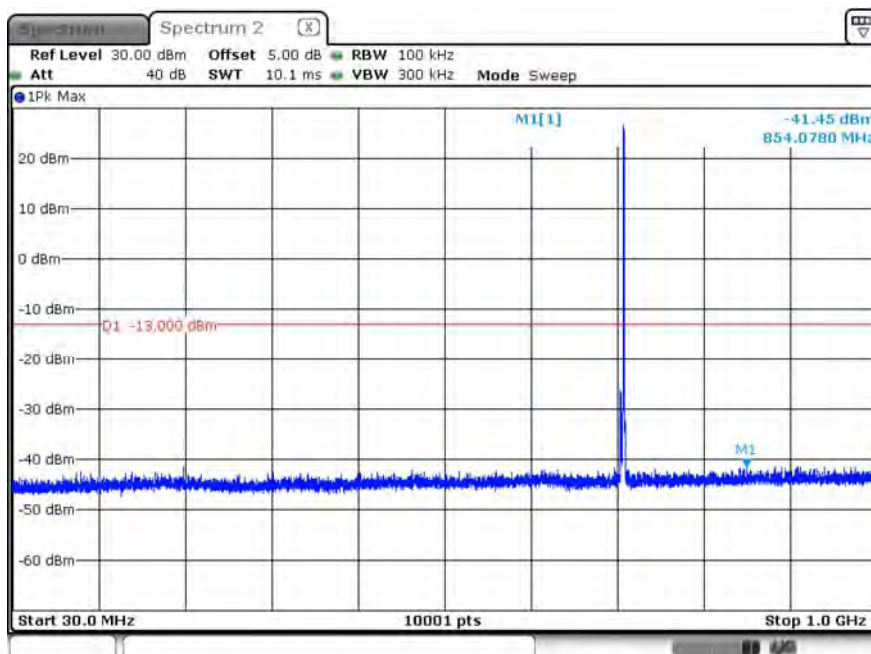

Date: 25 NOV.2020 02:57:02

B12_CH23060_10M_1RB0_QPSK_Above 1G

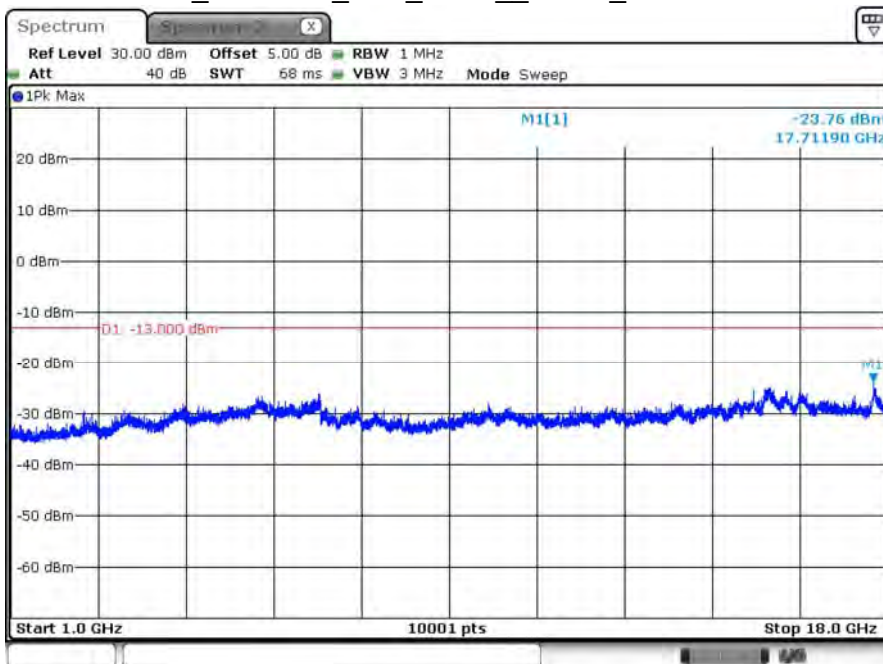

Date: 25 NOV.2020 02:46:58

B12_CH23060_10M_1RB0_QPSK_Below 1G

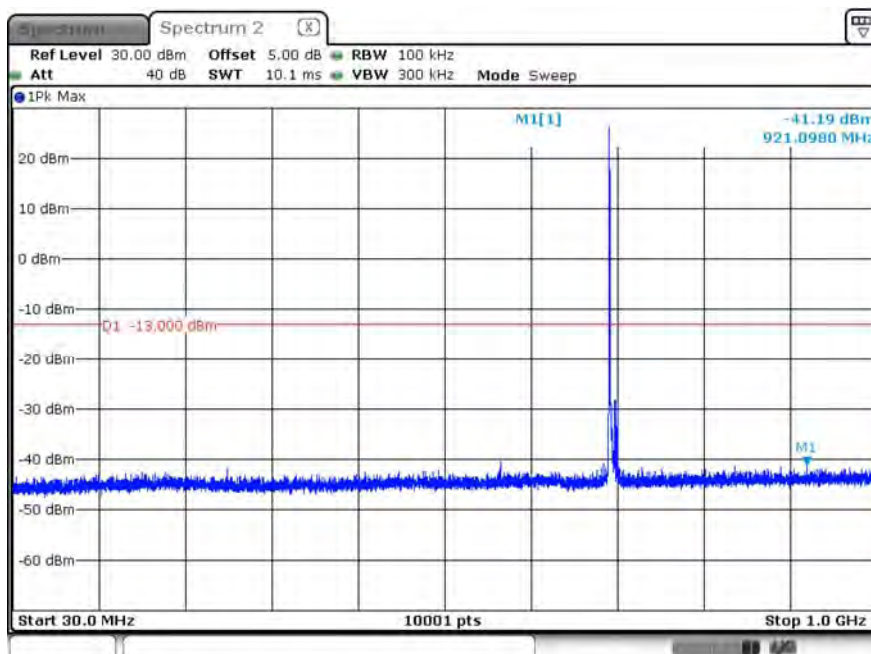

Date: 25 NOV.2020 02:45:30

B12_CH23095_10M_1RB0__QPSK_Above 1G

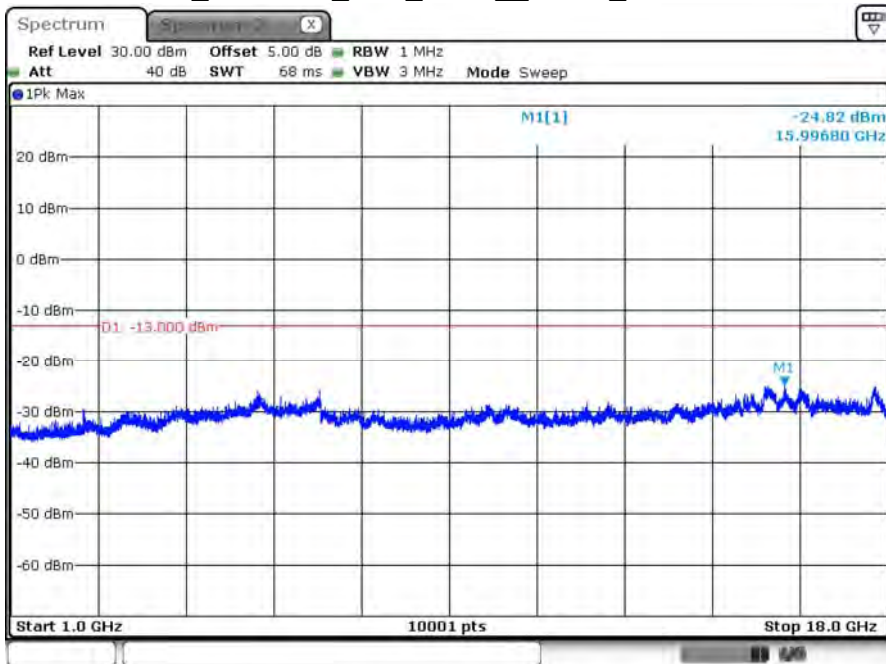

Date: 25 NOV.2020 02:48:00

B12_CH23095_10M_1RB0__QPSK_Below 1G

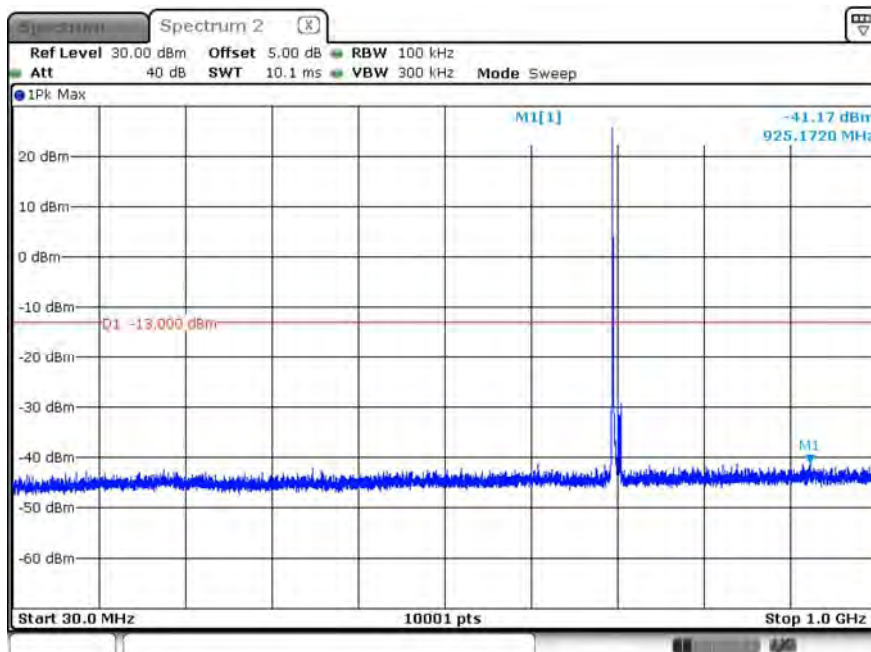

Date: 25 NOV.2020 02:48:51

B12_CH23130_10M_1RB0_QPSK_Above 1G

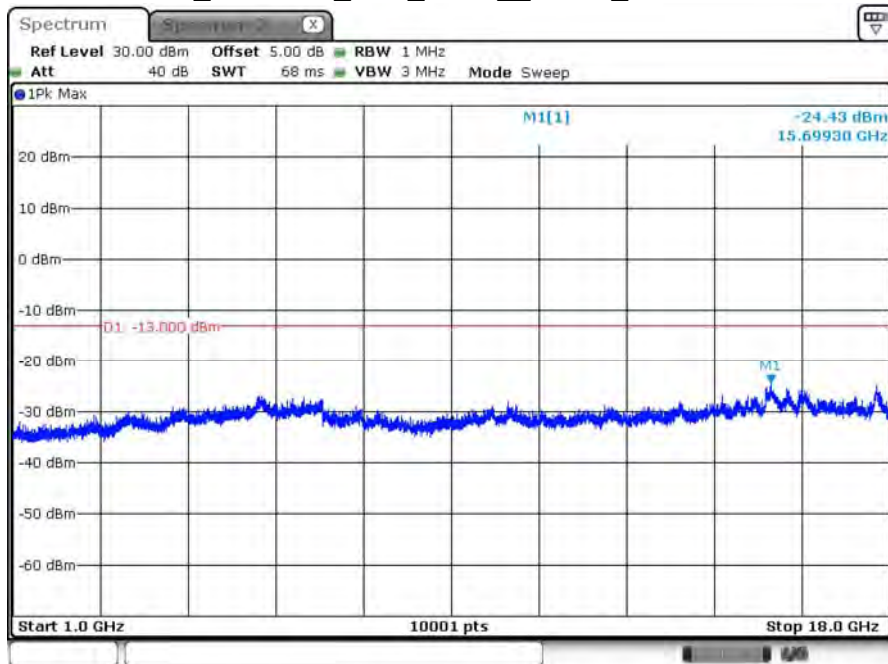

Date: 25 NOV.2020 02:41:49

B12_CH23130_10M_1RB0_QPSK_Below 1G

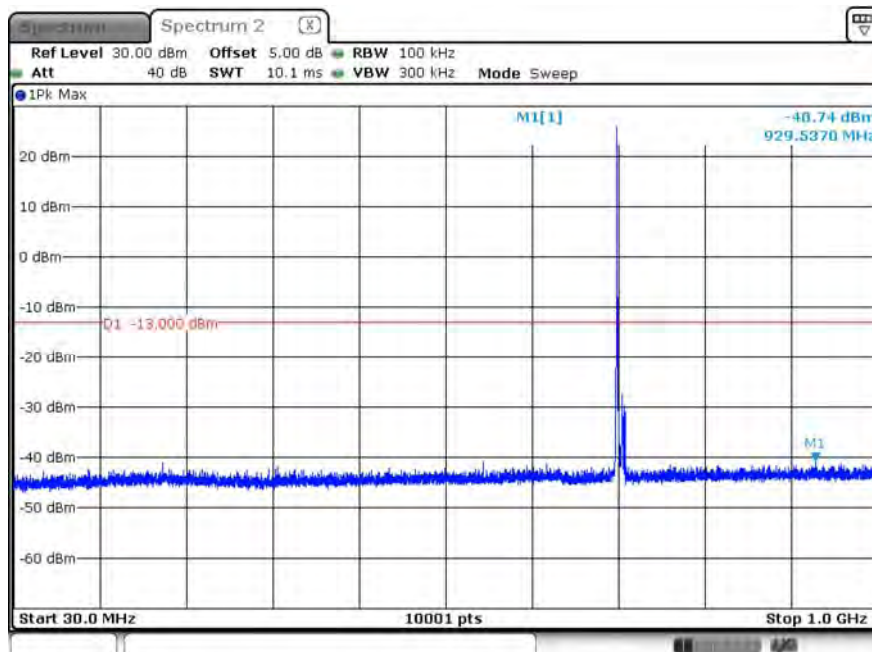

Date: 25 NOV.2020 02:43:37

Product	5G CPE		
Test Item	Spurious Emissions		
Test Mode	Mode 2: ENDC 14A_n66		
Date of Test	2020/11/25	Test Site	SR12-H
Temperature (°C)	23	Humidity (%RH)	63

B14_CH23305_5M_1RB0_QPSK_Above 1G

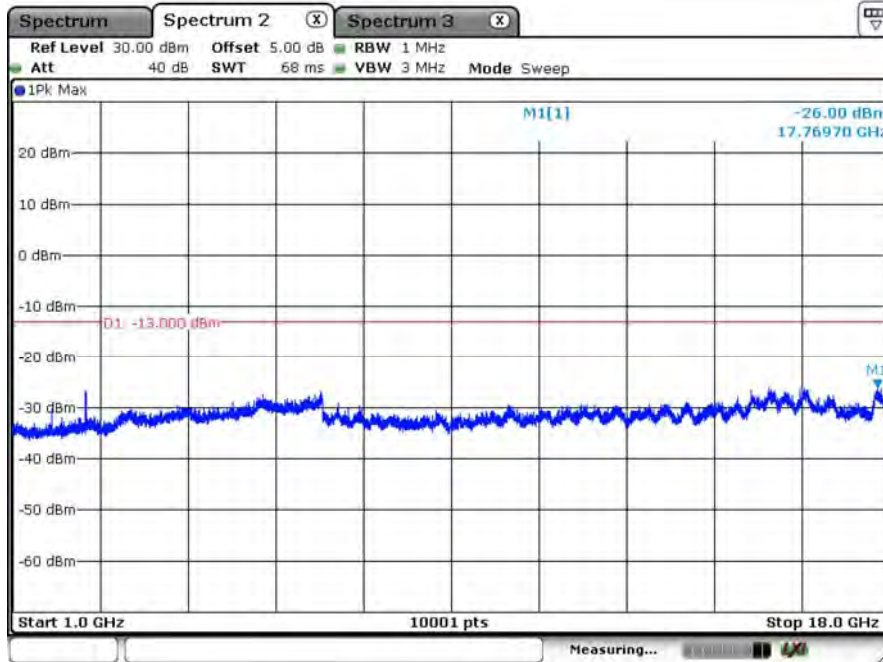

Date: 20.NOV.2020 10:18:49

B14_CH23305_5M_1RB0_QPSK_Below 1G

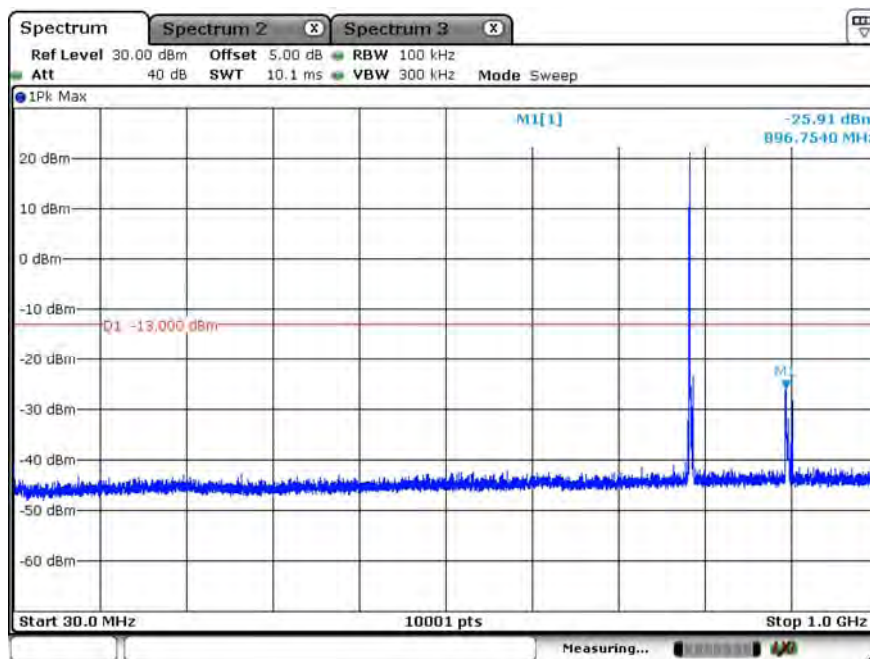

Date: 20.NOV.2020 10:20:10

B14_CH23330_5M_1RB0_QPSK_Above 1G

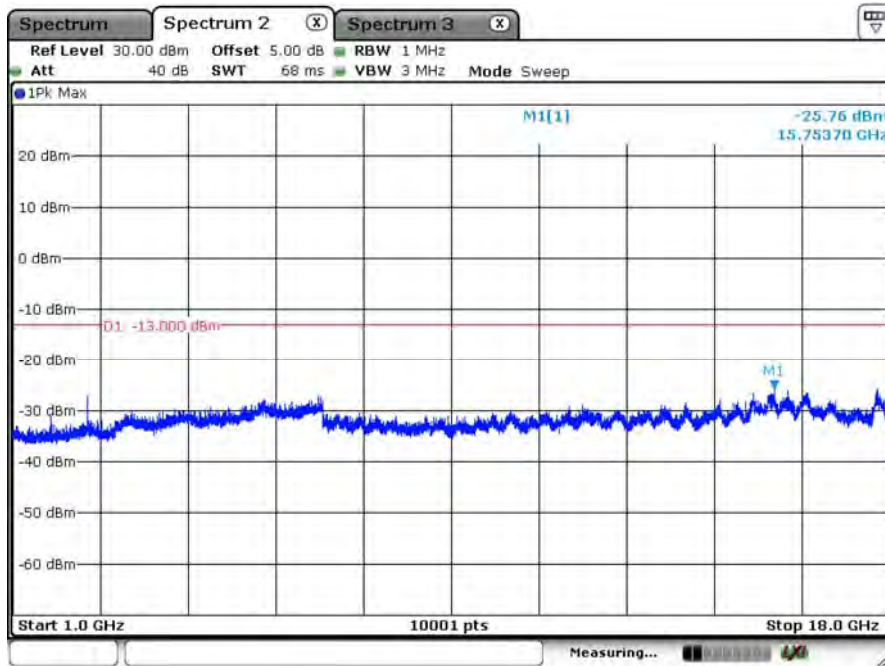

Date: 20.NOV.2020 10:25:33

B14_CH23330_5M_1RB0_QPSK_Below 1G

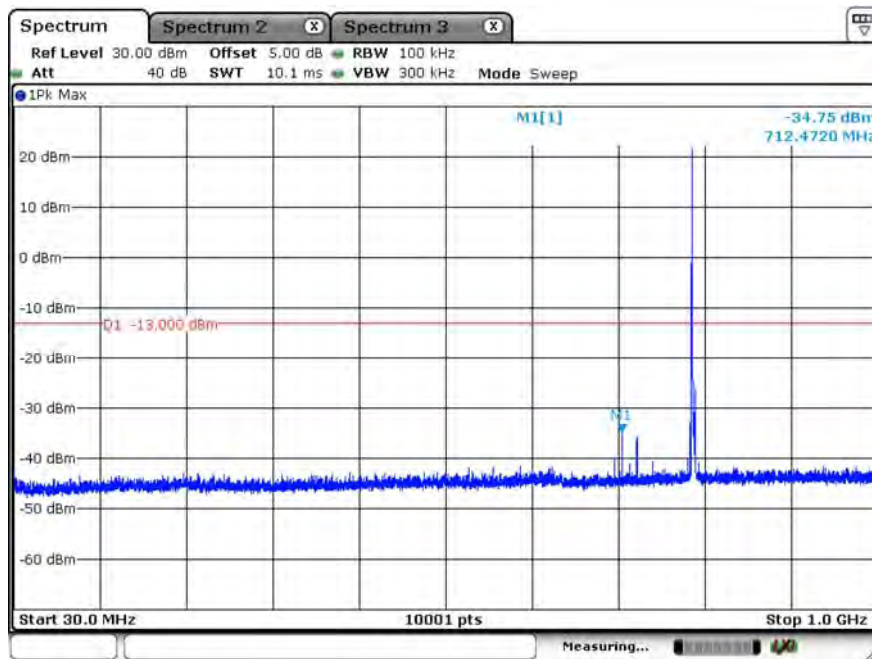

Date: 20.NOV.2020 10:24:53

B14_CH23355_5M_1RB0_QPSK_Above 1G

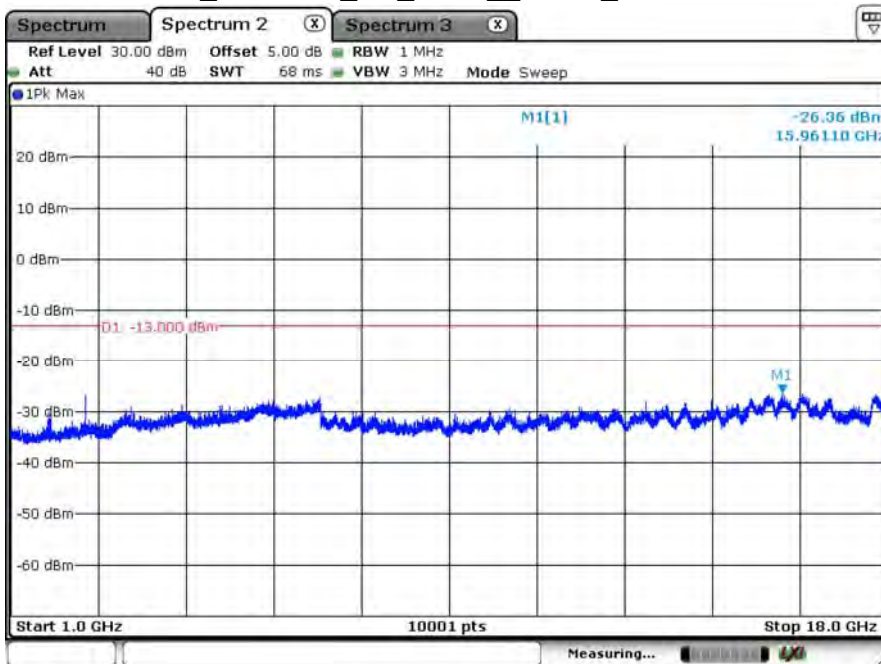

Date: 20.NOV.2020 10:26:47

B14_CH23355_5M_1RB0_QPSK_Below 1G

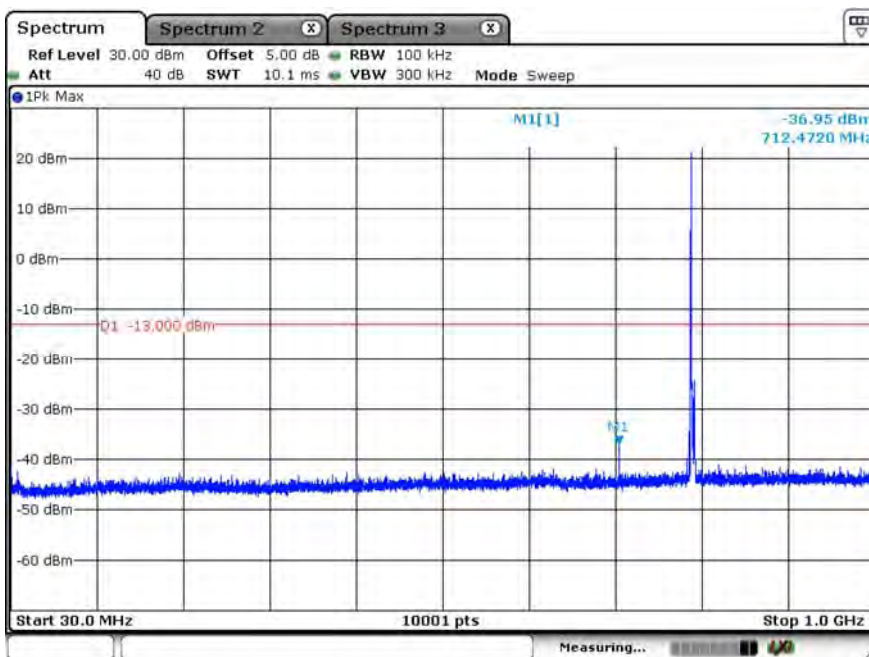

Date: 20.NOV.2020 10:28:04

B14_CH23330_10M_1RB0_QPSK_Above 1G

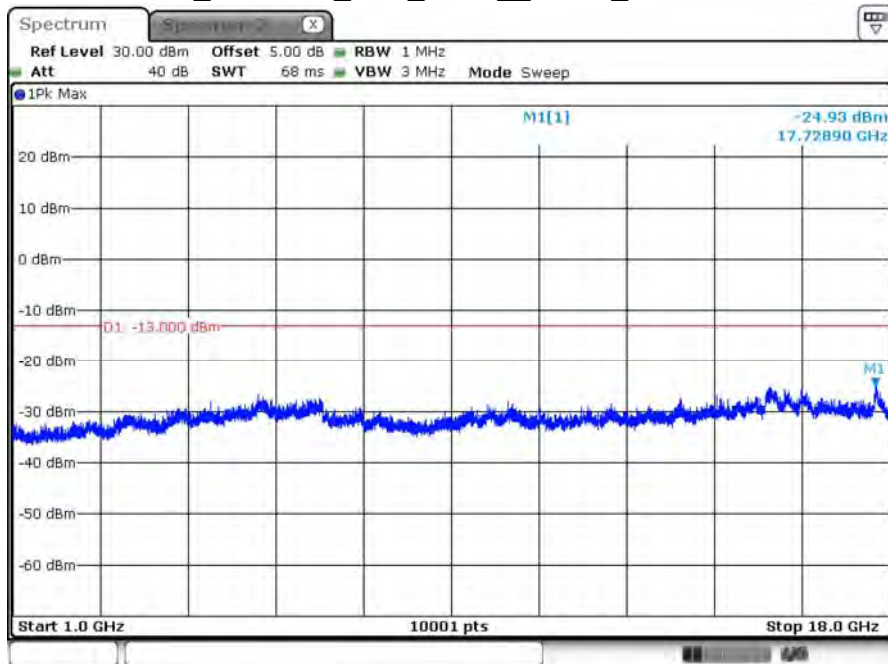

Date: 25 NOV.2020 02:38:42

B14_CH23330_10M_1RB0_QPSK_Below 1G

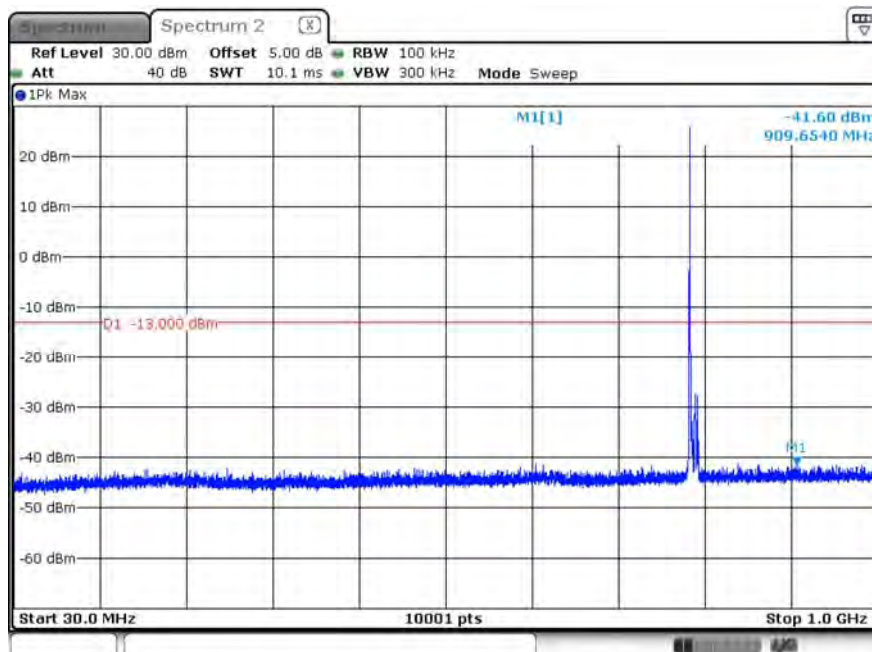

Date: 25 NOV.2020 02:37:54

Radiated Spurious Emission

Product	5G CPE		
Test Item	Spurious Emissions		
Test Mode	Mode 1: ENDC 12A_n2		
Date of Test	2020/11/24	Test Site	CB2-H
Temperature (°C)	25	Humidity (%RH)	56

10M_Ch 23060_QPSK_LTE Band 12

Antenna Polarity	Frequency (MHz)	Emission Level (dBm)	Limit (dBm)	Margin (dB)	SG Level (dBm)	Antenna Gain (dBi)	Cable Loss (dB)
H	1408.000	-55.19	-13	-42.19	-60.75	8.31	2.75
	2112.000	-36.13	-13	-23.13	-43.13	10.41	3.41
	2816.000	-52.90	-13	-39.90	-60.16	11.18	3.92
	3520.000	-51.50	-13	-38.50	-59.69	12.61	4.42
	4224.000	-49.99	-13	-36.99	-57.81	12.63	4.81
	4928.000	-48.33	-13	-35.33	-55.73	12.65	5.25
V	1408.000	-49.50	-13	-36.50	-55.06	8.31	2.75
	2112.000	-33.13	-13	-20.13	-40.13	10.41	3.41
	2816.000	-52.71	-13	-39.71	-59.97	11.18	3.92
	3520.000	-51.95	-13	-38.95	-60.14	12.61	4.42
	4224.000	-50.08	-13	-37.08	-57.90	12.63	4.81
	4928.000	-48.40	-13	-35.40	-55.80	12.65	5.25

Note:

1. Emission Level=SG(Signal Generator) Level+Antenna Gain-Cable Loss.
2. Sweep the whole frequency band through the range from 30MHz to the 10th harmonic of the carrier.
3. The spurious emissions within 30-1000MHz were found more than 20dB below the permissible value is not required to be report.

10M_Ch 23095_QPSK_LTE Band 12

Antenna Polarity	Frequency (MHz)	Emission Level (dBm)	Limit (dBm)	Margin (dB)	SG Level (dBm)	Antenna Gain (dBi)	Cable Loss (dB)
H	1415.000	-47.38	-13	-34.38	-52.98	8.35	2.75
	2122.500	-31.60	-13	-18.60	-38.59	10.41	3.42
	2830.000	-52.00	-13	-39.00	-59.28	11.21	3.93
	3537.500	-51.17	-13	-38.17	-59.35	12.61	4.43
	4245.000	-49.46	-13	-36.46	-57.26	12.63	4.83
	4952.500	-48.55	-13	-35.55	-55.94	12.65	5.26
V	1415.000	-51.13	-13	-38.13	-56.73	8.35	2.75
	2122.500	-32.09	-13	-19.09	-39.08	10.41	3.42
	2830.000	-51.82	-13	-38.82	-59.10	11.21	3.93
	3537.500	-52.11	-13	-39.11	-60.29	12.61	4.43
	4245.000	-50.17	-13	-37.17	-57.97	12.63	4.83
	4952.500	-48.22	-13	-35.22	-55.61	12.65	5.26

Note:

1. Emission Level=SG(Signal Generator) Level+Antenna Gain-Cable Loss.
2. Sweep the whole frequency band through the range from 30MHz to the 10th harmonic of the carrier.
3. The spurious emissions within 30-1000MHz were found more than 20dB below the permissible value is not required to be report.

10M_Ch 23130_QPSK_LTE Band 12

Antenna Polarity	Frequency (MHz)	Emission Level (dBm)	Limit (dBm)	Margin (dB)	SG Level (dBm)	Antenna Gain (dBi)	Cable Loss (dB)
H	1422.000	-52.31	-13	-39.31	-57.94	8.39	2.76
	2133.000	-41.52	-13	-28.52	-48.51	10.42	3.42
	2844.000	-51.91	-13	-38.91	-59.21	11.23	3.94
	3555.000	-51.74	-13	-38.74	-59.91	12.61	4.44
	4266.000	-49.49	-13	-36.49	-57.28	12.63	4.84
	4977.000	-48.10	-13	-35.10	-55.47	12.65	5.28
V	1422.000	-54.58	-13	-41.58	-60.21	8.39	2.76
	2133.000	-46.39	-13	-33.39	-53.38	10.42	3.42
	2844.000	-52.78	-13	-39.78	-60.08	11.23	3.94
	3555.000	-51.61	-13	-38.61	-59.78	12.61	4.44
	4266.000	-50.27	-13	-37.27	-58.06	12.63	4.84
	4977.000	-48.52	-13	-35.52	-55.89	12.65	5.28

Note:

1. Emission Level=SG(Signal Generator) Level+Antenna Gain-Cable Loss.
2. Sweep the whole frequency band through the range from 30MHz to the 10th harmonic of the carrier.
3. The spurious emissions within 30-1000MHz were found more than 20dB below the permissible value is not required to be report.

Product	5G CPE		
Test Item	Spurious Emissions		
Test Mode	Mode 2: ENDC 14A_n66		
Date of Test	2020/11/24	Test Site	CB2-H
Temperature (°C)	25	Humidity (%RH)	56

10M_Ch 23330_QPSK_LTE Band 14

Antenna Polarity	Frequency (MHz)	Emission Level (dBm)	Limit (dBm)	Margin (dB)	SG Level (dBm)	Antenna Gain (dBi)	Cable Loss (dB)
H	1586.000	-41.83	-40	-1.83	-48.00	9.10	2.93
	2379.000	-29.93	-13	-16.93	-36.86	10.54	3.61
	3172.000	-50.05	-13	-37.05	-57.78	11.89	4.17
	3965.000	-47.08	-13	-34.08	-55.04	12.60	4.64
	4758.000	-48.64	-13	-35.64	-56.14	12.65	5.15
	5551.000	-48.61	-13	-35.61	-56.07	13.13	5.67
V	1586.000	-41.41	-40	-1.41	-47.58	9.10	2.93
	2379.000	-30.48	-13	-17.48	-37.41	10.54	3.61
	3172.000	-51.07	-13	-38.07	-58.80	11.89	4.17
	3965.000	-50.67	-13	-37.67	-58.63	12.60	4.64
	4758.000	-48.44	-13	-35.44	-55.94	12.65	5.15
	5551.000	-48.50	-13	-35.50	-55.96	13.13	5.67

Note:

1. Emission Level=SG(Signal Generator) Level+Antenna Gain-Cable Loss.
2. Sweep the whole frequency band through the range from 30MHz to the 10th harmonic of the carrier.
3. The spurious emissions within 30-1000MHz were found more than 20dB below the permissible value is not required to be report.

Product	5G CPE		
Test Item	Spurious Emissions		
Test Mode	Mode 3: ENDC 2A_n66		
Date of Test	2020/11/19	Test Site	CB2-H
Temperature (°C)	22	Humidity (%RH)	55

15M_Ch 354500_PI/2_5G n66

Antenna Polarity	Frequency (MHz)	Emission Level (dBm)	Limit (dBm)	Margin (dB)	SG Level (dBm)	Antenna Gain (dBi)	Cable Loss (dB)
H	3545.000	-51.89	-13	-38.89	-60.07	12.61	4.43
	5317.500	-51.15	-13	-38.15	-58.59	12.96	5.52
	7090.000	-45.62	-13	-32.62	-50.64	11.58	6.55
V	3545.000	-51.69	-13	-38.69	-59.87	12.61	4.43
	5317.500	-51.06	-13	-38.06	-58.50	12.96	5.52
	7090.000	-45.56	-13	-32.56	-50.58	11.58	6.55

Note:

1. Emission Level=SG(Signal Generator) Level+Antenna Gain-Cable Loss.
2. Sweep the whole frequency band through the range from 30MHz to the 10th harmonic of the carrier.
3. The spurious emissions within 30-1000MHz were found more than 20dB below the permissible value is not required to be report.

Product	5G CPE		
Test Item	Spurious Emissions		
Test Mode	Mode 4: ENDC 5A_n2		
Date of Test	2020/11/19	Test Site	CB2-H
Temperature (°C)	22	Humidity (%RH)	55

10M_Ch 381000_PI/2_5G n2

Antenna Polarity	Frequency (MHz)	Emission Level (dBm)	Limit (dBm)	Margin (dB)	SG Level (dBm)	Antenna Gain (dBi)	Cable Loss (dB)
H	3810.000	-51.35	-13	-38.35	-59.39	12.60	4.56
	5715.000	-47.86	-13	-34.86	-55.22	13.08	5.72
	7620.000	-42.82	-13	-29.82	-47.46	11.24	6.60
V	3810.000	-50.92	-13	-37.92	-58.96	12.60	4.56
	5715.000	-47.56	-13	-34.56	-54.92	13.08	5.72
	7620.000	-42.85	-13	-29.85	-47.49	11.24	6.60

Note:

1. Emission Level=SG(Signal Generator) Level+Antenna Gain-Cable Loss.
2. Sweep the whole frequency band through the range from 30MHz to the 10th harmonic of the carrier.
3. The spurious emissions within 30-1000MHz were found more than 20dB below the permissible value is not required to be report.

Product	5G CPE		
Test Item	Spurious Emissions		
Test Mode	Mode 5: ENDC 66A_n5		
Date of Test	2020/11/19	Test Site	CB2-H
Temperature (°C)	22	Humidity (%RH)	55

15M_Ch 166300_PI/2_5G n5

Antenna Polarity	Frequency (MHz)	Emission Level (dBm)	Limit (dBm)	Margin (dB)	SG Level (dBm)	Antenna Gain (dBi)	Cable Loss (dB)
H	1663.000	-59.24	-13	-46.24	-65.57	9.33	3.00
	2494.500	-52.93	-13	-39.93	-59.83	10.60	3.70
	3326.000	-53.32	-13	-40.32	-61.27	12.23	4.28
V	1663.000	-59.11	-13	-46.11	-65.44	9.33	3.00
	2494.500	-52.92	-13	-39.92	-59.82	10.60	3.70
	3326.000	-53.42	-13	-40.42	-61.37	12.23	4.28

Note:

1. Emission Level=SG(Signal Generator) Level+Antenna Gain-Cable Loss.
2. Sweep the whole frequency band through the range from 30MHz to the 10th harmonic of the carrier.
3. The spurious emissions within 30-1000MHz were found more than 20dB below the permissible value is not required to be report.

Note:

This report is prepared for Class II permissive change. The difference compared with original report no.: 2050962R-E3042110012-A is housing and software. The software changes as following:

- 1) Add LTE band 4, band 12, band 14, band 29 and close band 13 by software.
- 2) Close 5G FR2 band n261 by software.

According to above conditions, LTE band 12/ 14 and added EN-DC combination testing and Radiated Spurious Emissions (RSE) worst-case need to be performed and all data were verified to meet the requirements, and other test data refer to original report.

All RSE of EN-DC combination modes have been investigated and recorded worst-case in this report.

7. Spurious Emissions at Antenna Terminals

7.1. Test Setup

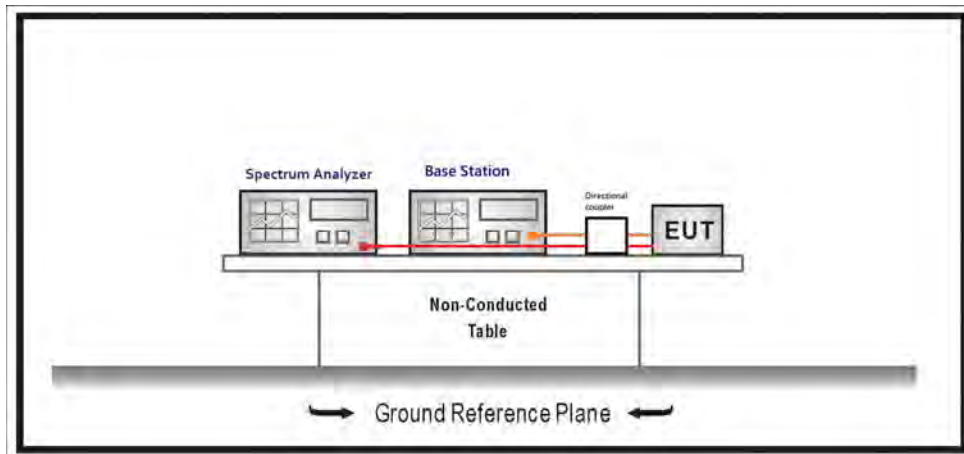

7.2. Test Procedure

- Place the EUT on a bench and set it in transmitting mode.
- Connect a low loss RF cable from the antenna port to a spectrum analyzer and CMW500 by a Directional Coupler.
- EUT Communicate with CMW500, then select a channel for testing.
- Add a correction factor to the display of spectrum, and then test.
- All measurements were done at low and high operational frequency range.
- Record the max trace plot into the test report.

7.3. Test Method

KDB 971168 D01 Power Meas License Digital Systems v03 sub-clause 6.1
ANSI C63.26-2015 Sub-clause 5.7

7.4. Test Result

Product	5G CPE		
Test Item	Spurious Emissions at Antenna Terminals		
Test Mode	Mode 1: ENDC 12A_n2		
Date of Test	2020/11/25	Test Site	SR12-H
Temperature (°C)	23	Humidity (%RH)	63

LTE_B12_CH23017_1.4M_QPSK_1RB0

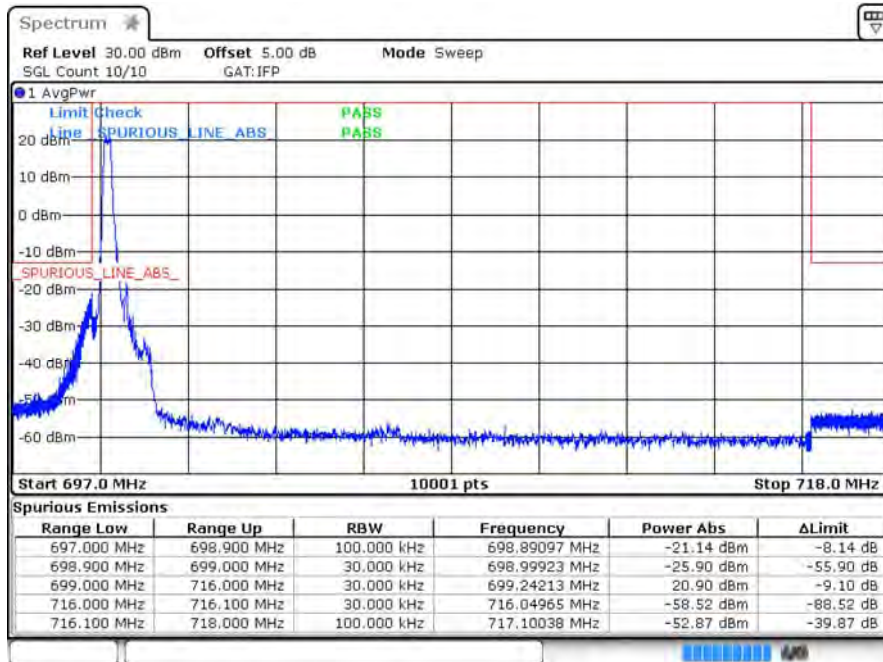

Date: 25 NOV. 2020 05:11:29

LTE_B12_CH23017_1.4M_QPSK_6RB0

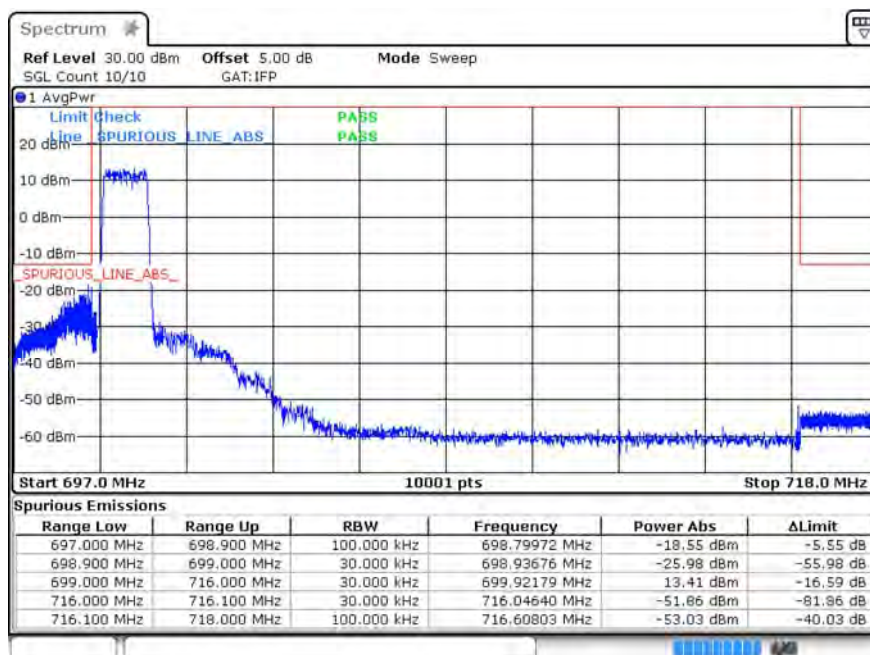

Date: 25 NOV. 2020 05:12:16

LTE_B12_CH23173_1.4M_QPSK_1RB5

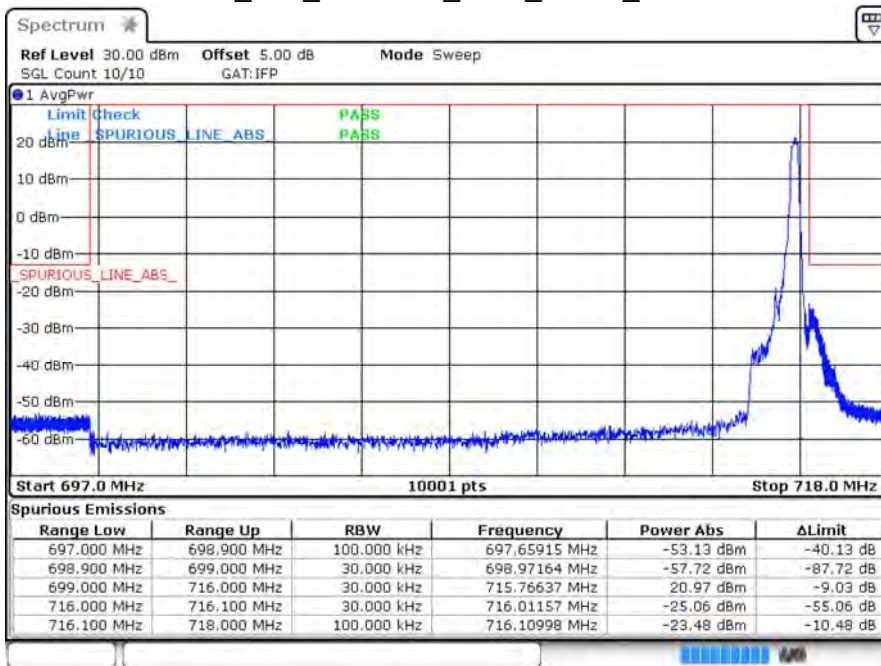

Date: 25 NOV 2020 05:13:25

LTE_B12_CH23173_1.4M_QPSK_6RB0

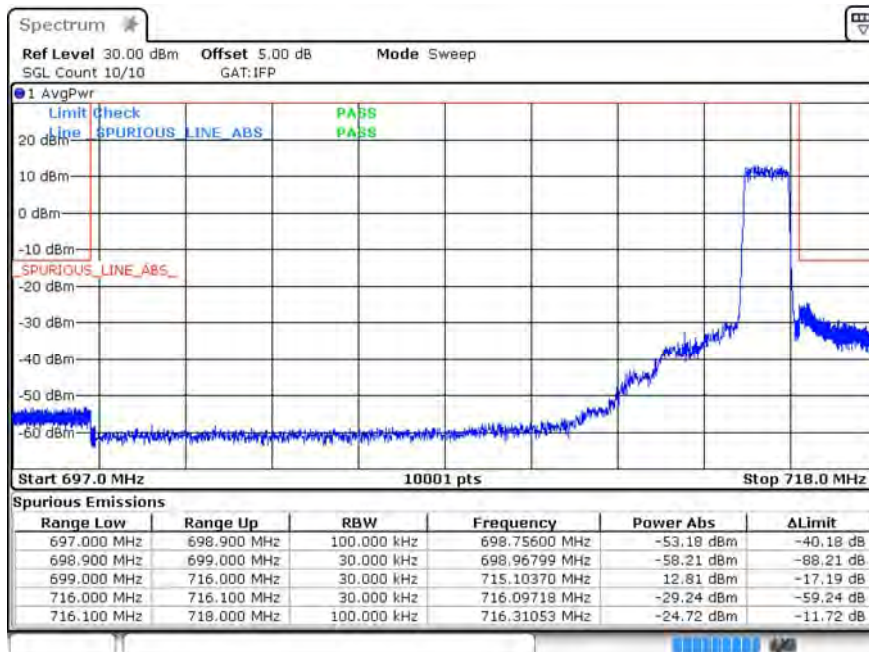

Date: 25 NOV 2020 05:12:52

LTE_B12_CH23025_3M_QPSK_1RB0

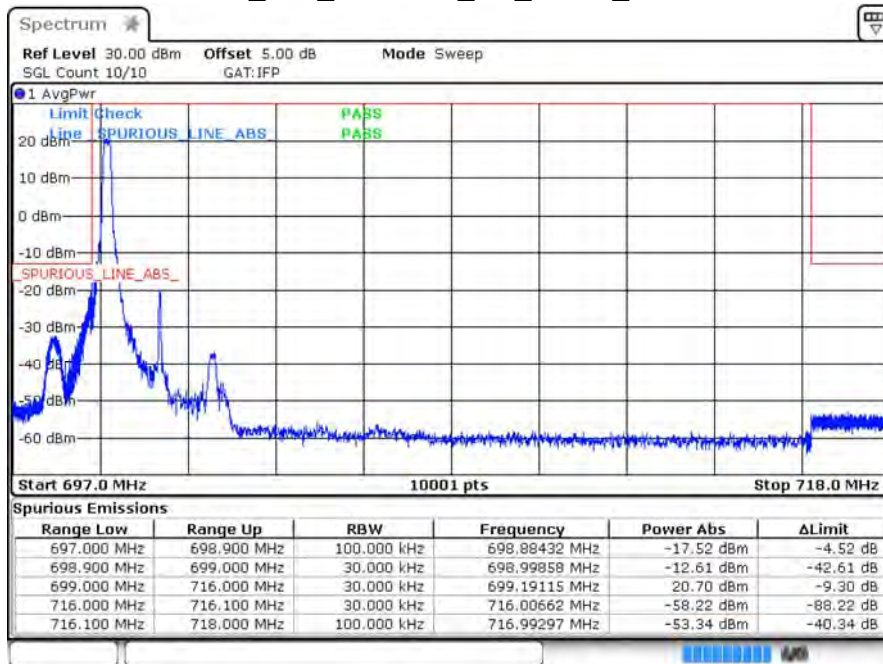

Date: 25 NOV 2020 05:15:56

LTE_B12_CH23025_3M_QPSK_15RB0

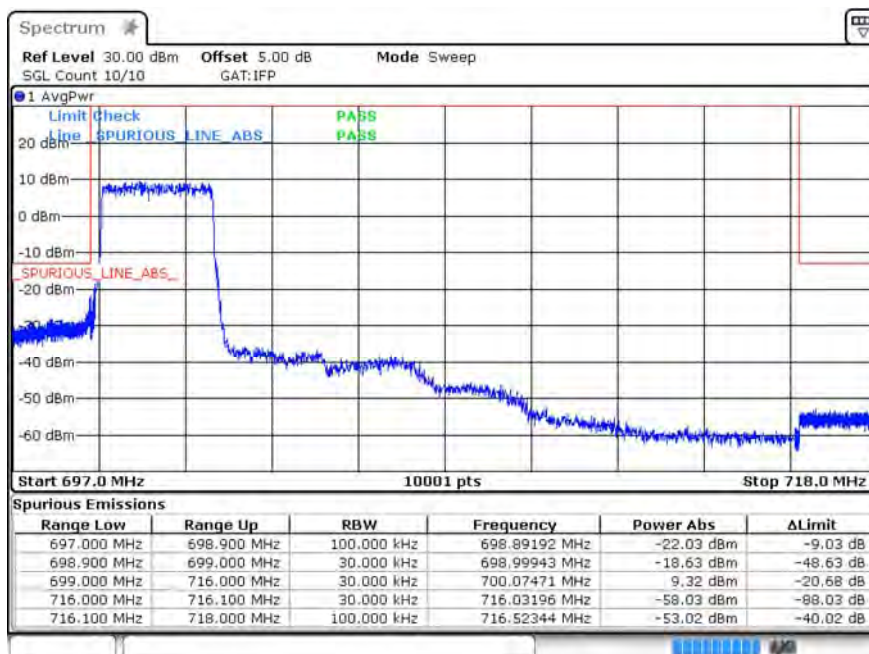

Date: 25 NOV 2020 05:17:03

LTE_B12_CH23165_3M_QPSK_1RB14

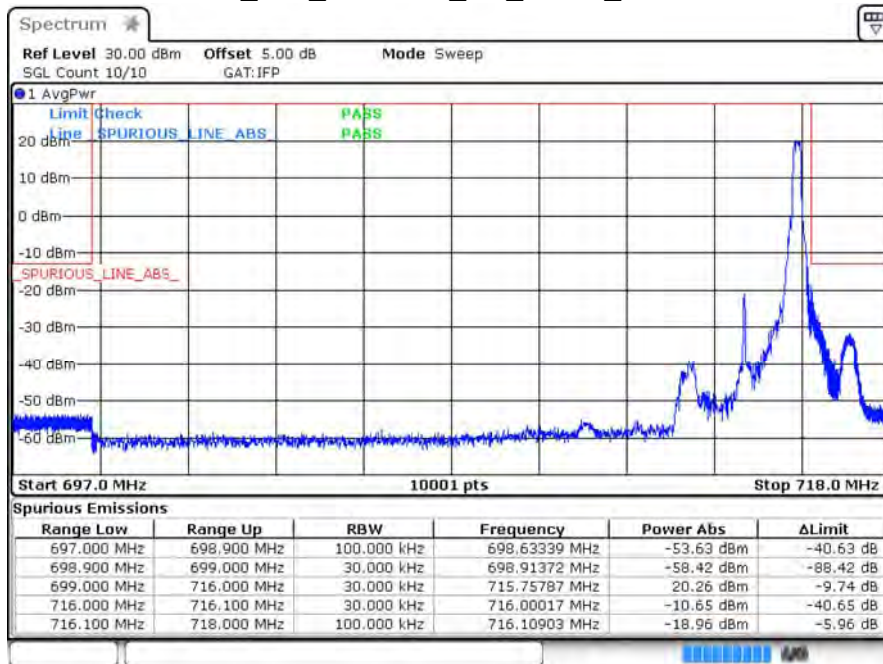

Date: 25 NOV 2020 05:18:32

LTE_B12_CH23165_3M_QPSK_15RB0

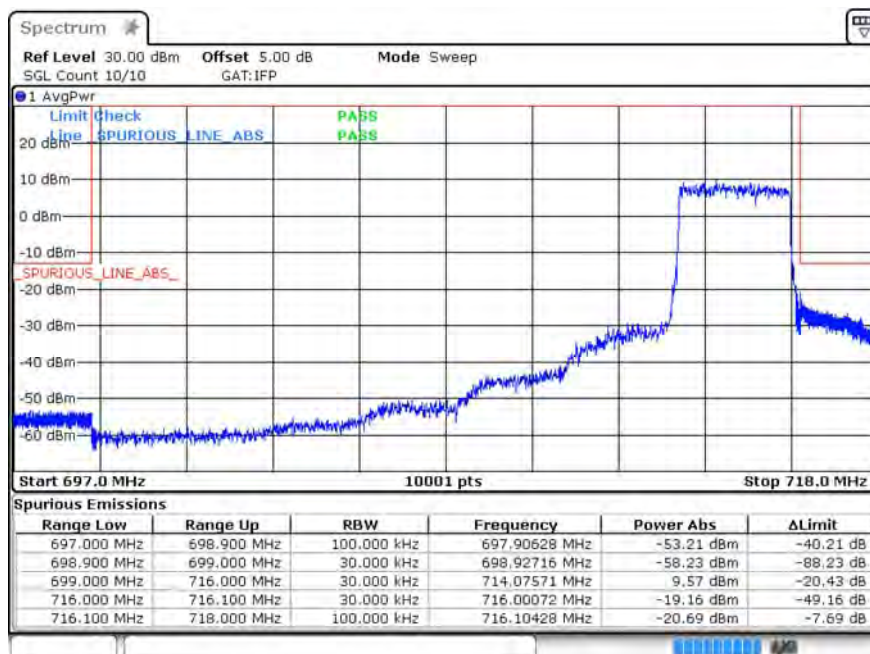

Date: 25 NOV 2020 05:18:04

LTE_B12_CH23035_5M_QPSK_1RB0

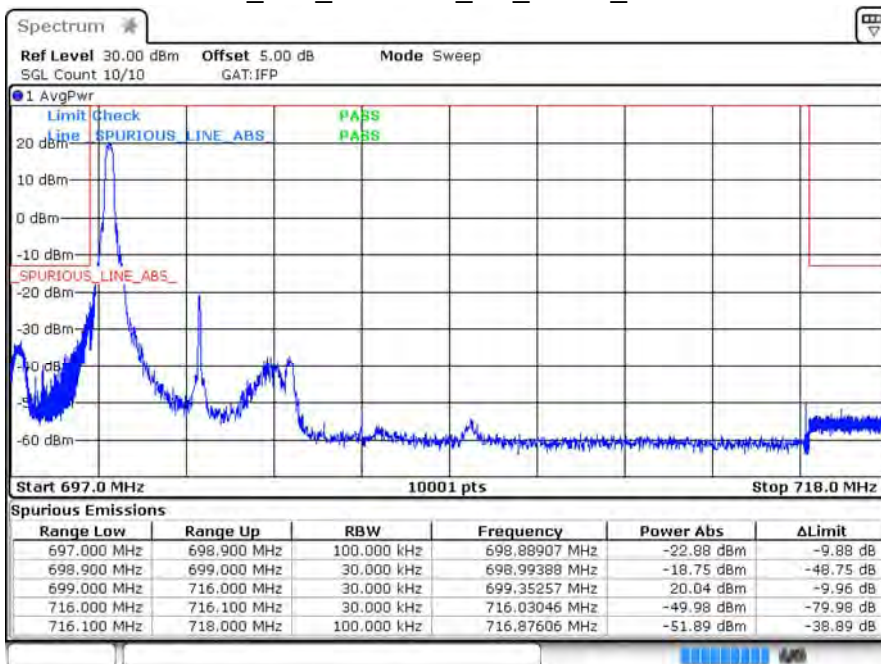

Date: 25 NOV 2020 05:22:45

LTE_B12_CH23035_5M_QPSK_25RB0

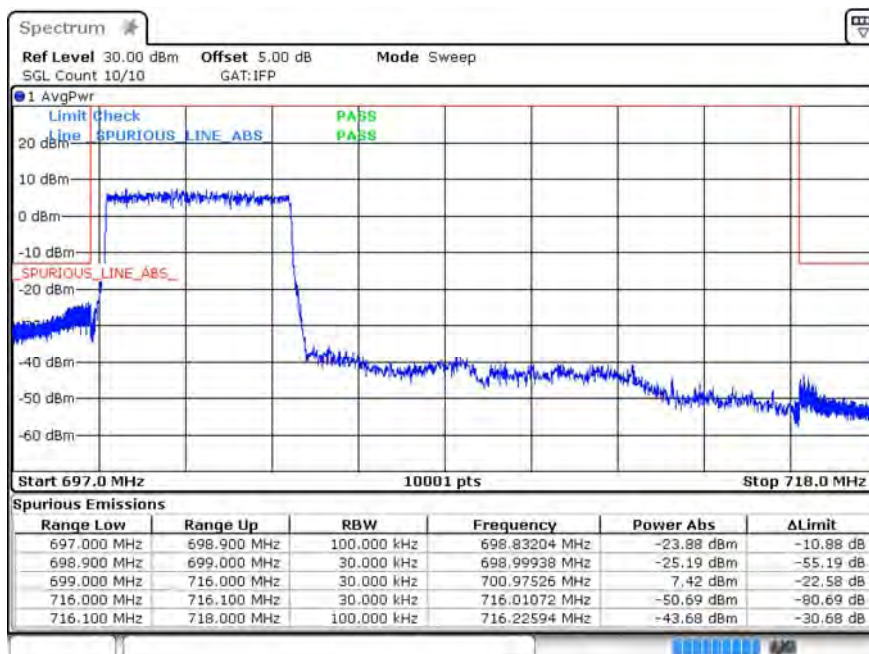

Date: 25 NOV 2020 05:22:02

LTE_B12_CH23155_5M_QPSK_1RB24

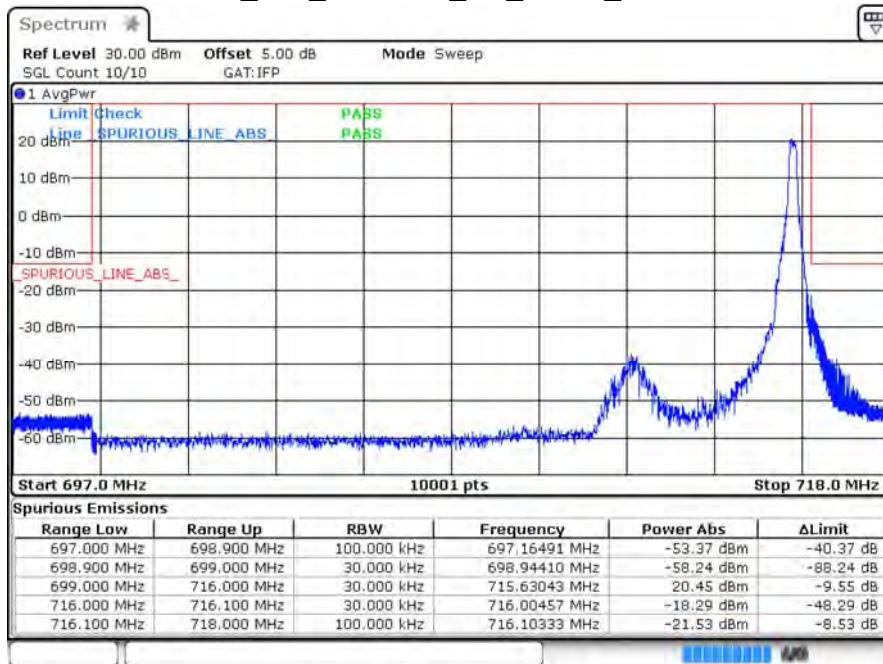

Date: 25 NOV 2020 05:20:22

LTE_B12_CH23155_5M_QPSK_25RB0

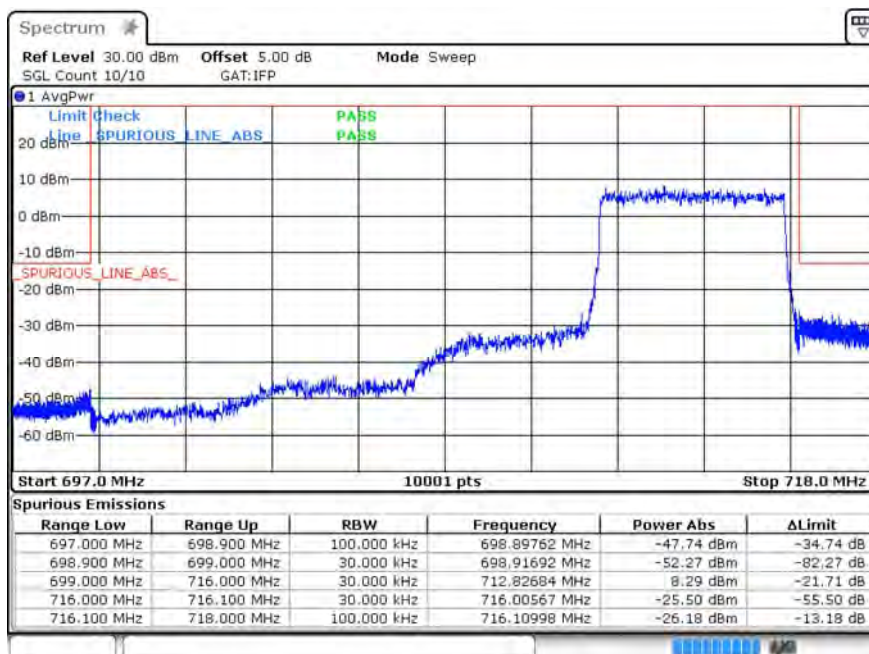

Date: 25 NOV 2020 05:21:11

LTE_B12_CH23060_10M_QPSK_1RB0

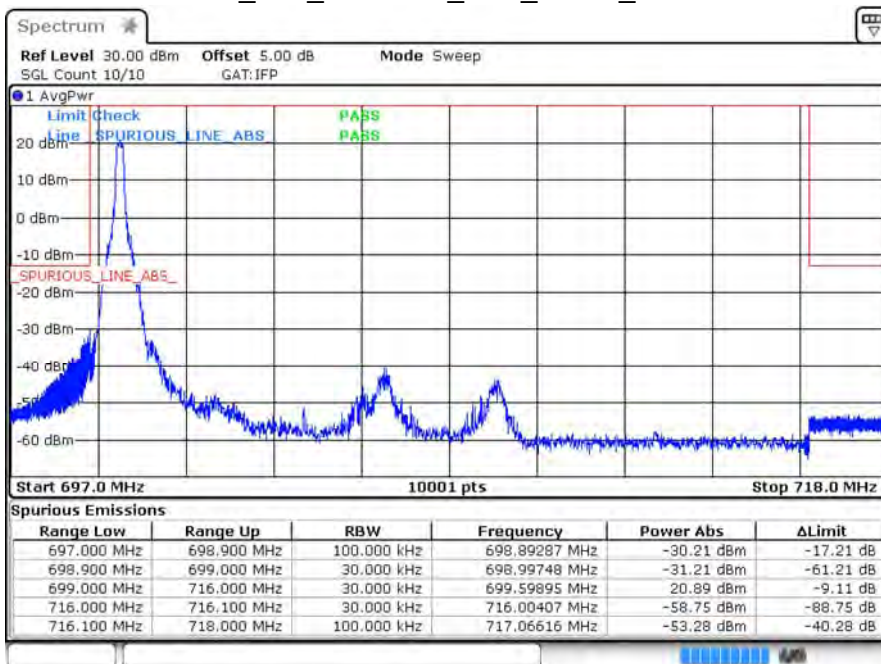

Date: 25 NOV 2020 05:25:44

LTE_B12_CH23060_10M_QPSK_50RB0

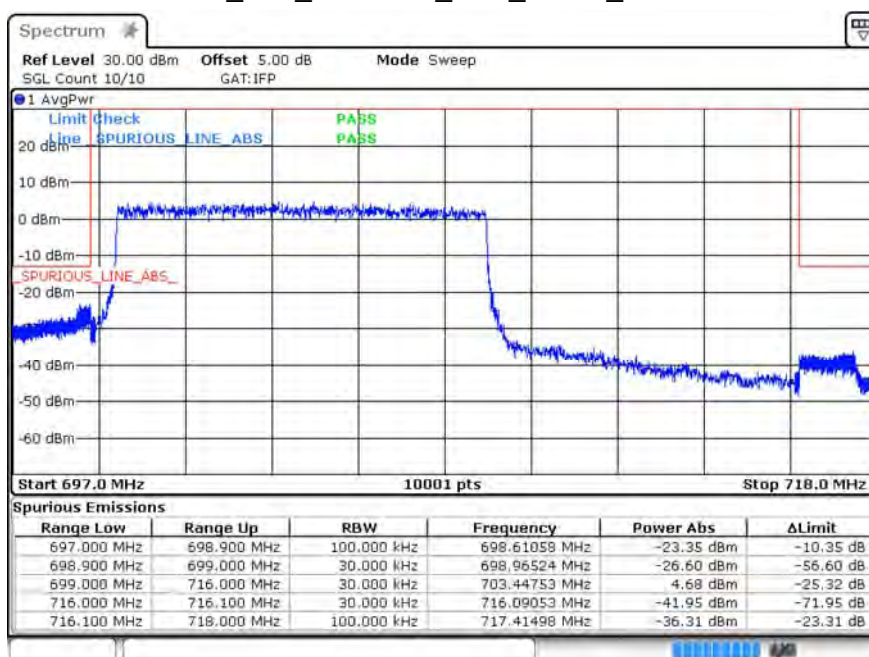

Date: 25 NOV 2020 05:26:37

LTE_B12_CH23130_10M_QPSK_1RB49

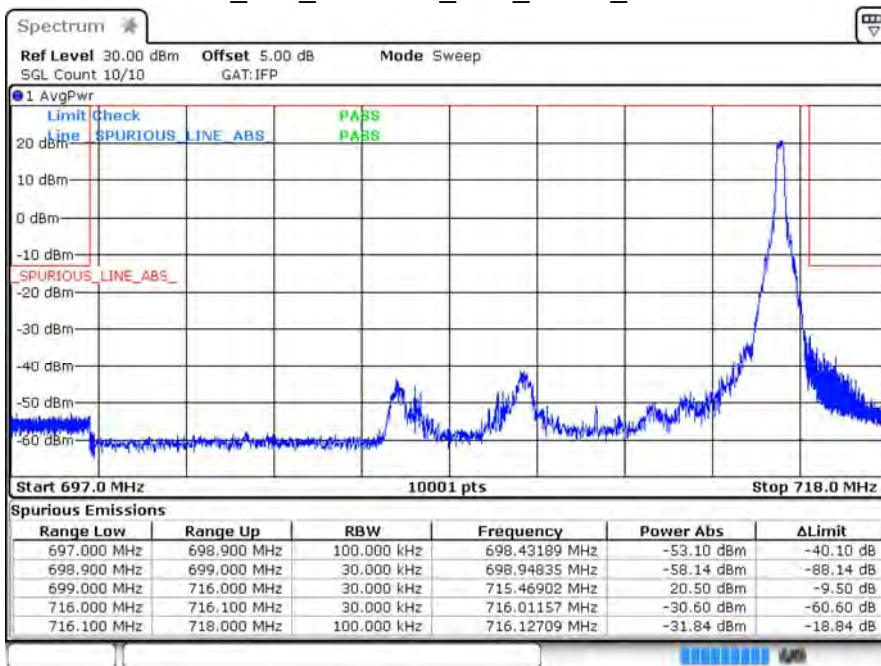

Date: 25 NOV 2020 05:27:48

LTE_B12_CH23130_10M_QPSK_50RB0

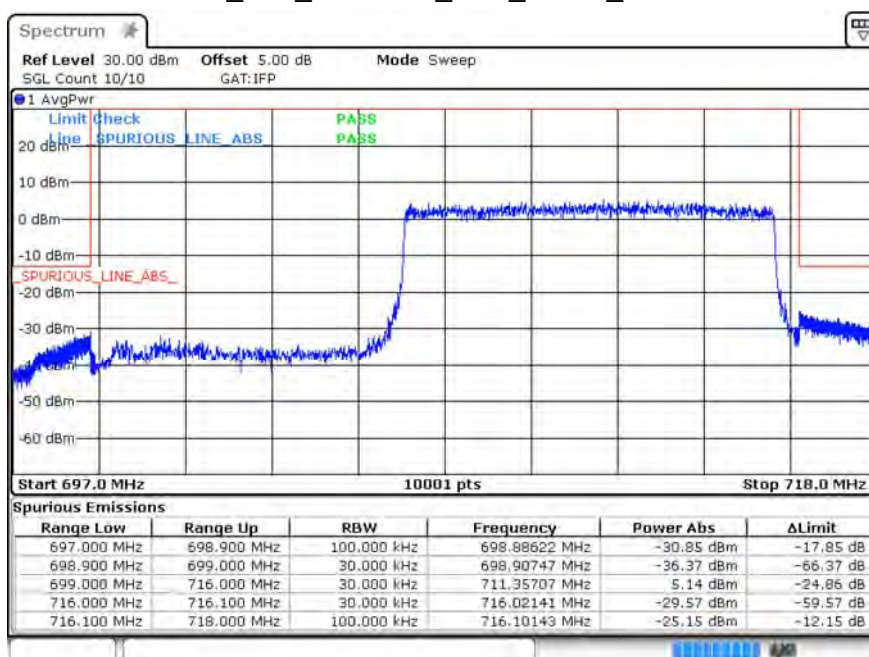

Date: 25 NOV 2020 05:27:12

Product	5G CPE		
Test Item	Spurious Emissions at Antenna Terminals		
Test Mode	Mode 2: ENDC 14A_n66		
Date of Test	2020/11/25	Test Site	SR12-H
Temperature (°C)	23	Humidity (%RH)	63

LTE_B14_CH23305_5M_QPSK_1RB0

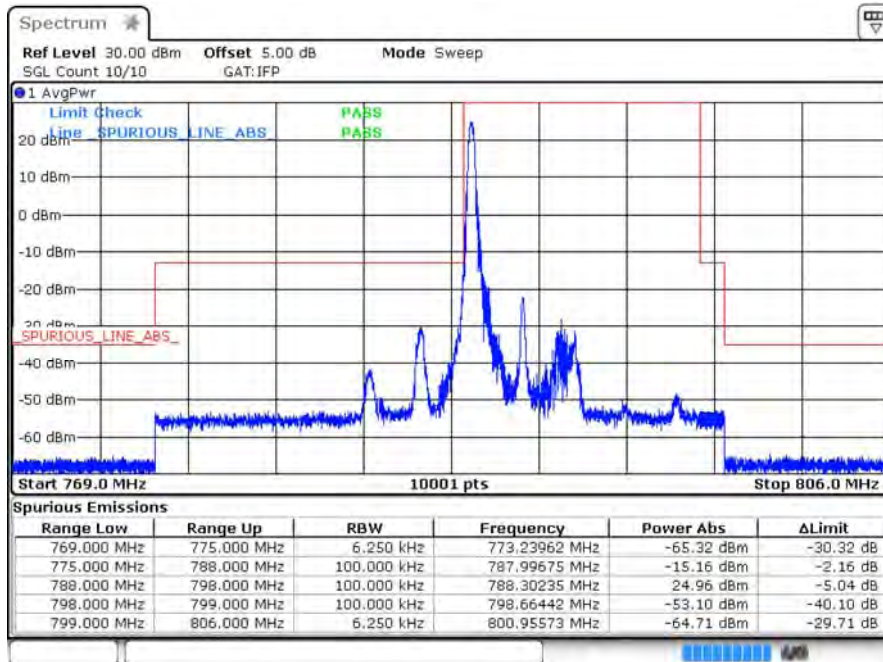

Date: 25 NOV.2020 05:38:24

LTE_B14_CH23305_5M_QPSK_25RB0

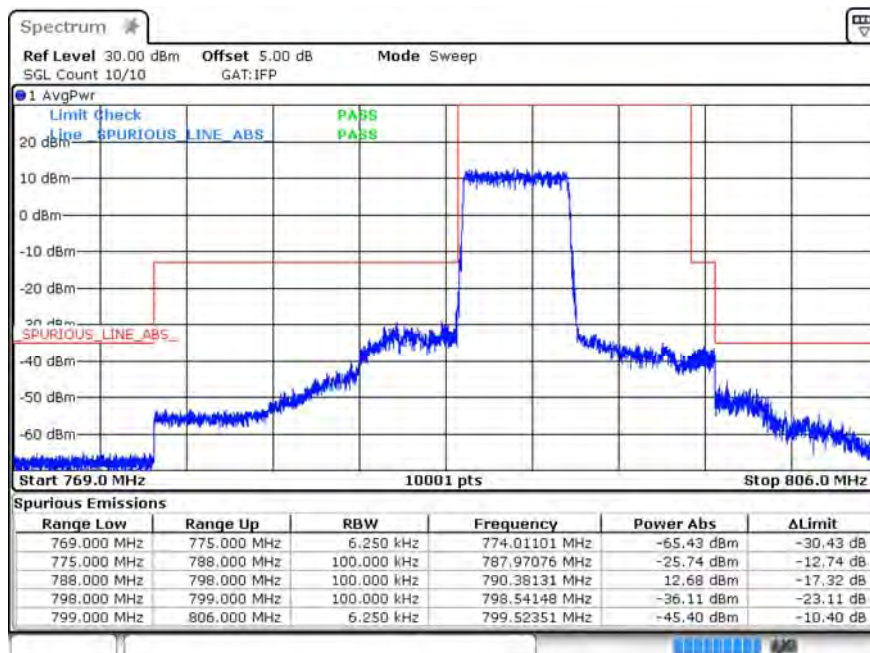

Date: 25 NOV.2020 05:40:51

LTE_B14_CH23355_5M_QPSK_1RB24

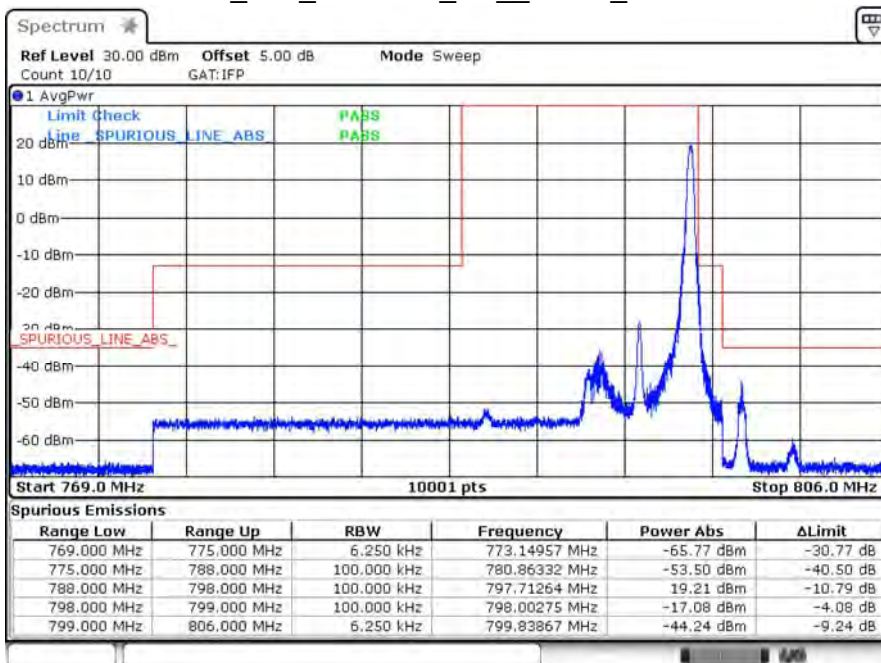

Date: 25 NOV 2020 05:50:23

LTE_B14_CH23355_5M_QPSK_25RB0

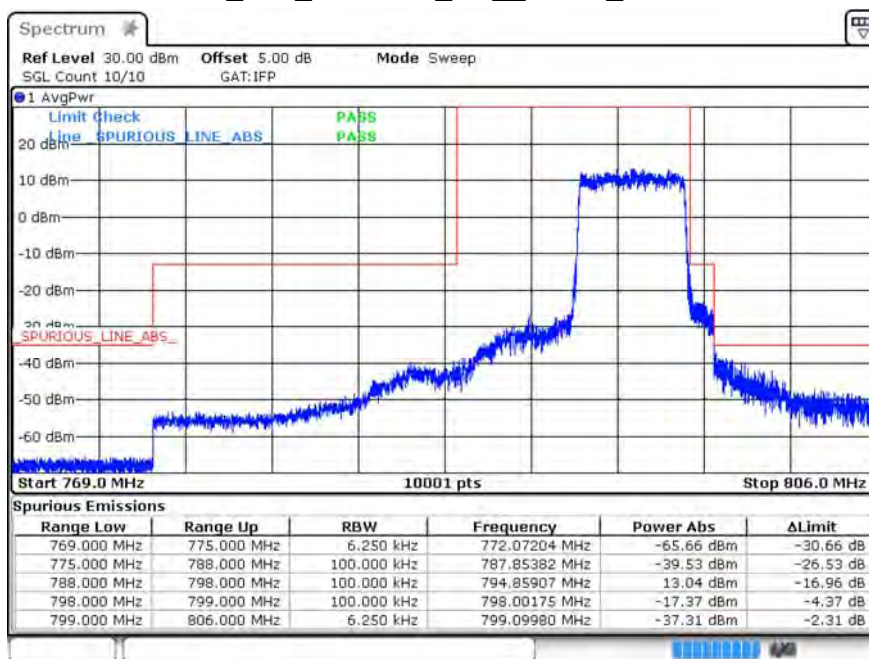

Date: 25 NOV 2020 05:41:43

LTE_B14_CH23330_10M_QPSK_1RB0

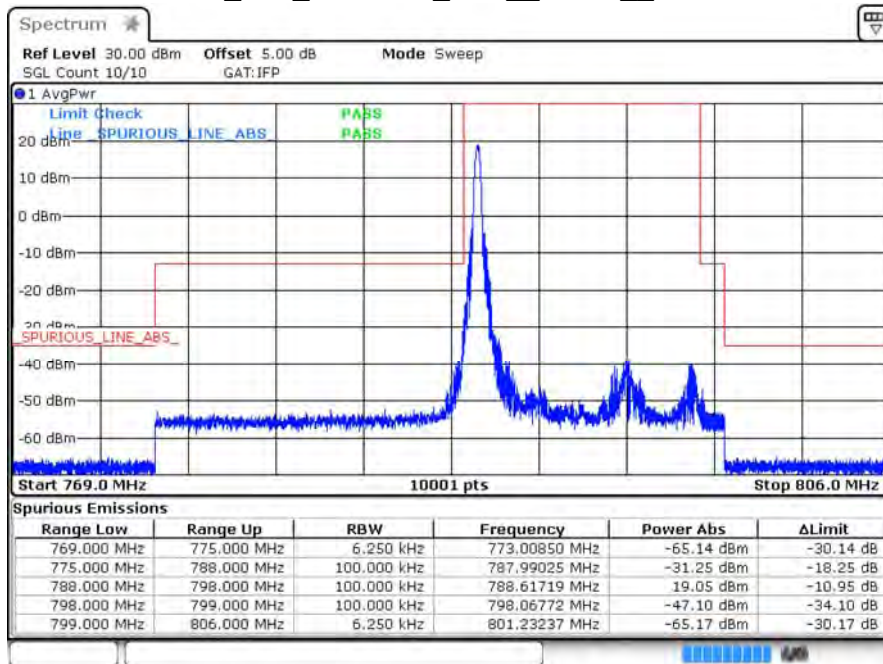

Date: 25 NOV.2020 06:20:14

LTE_B14_CH23330_10M_QPSK_1RB49

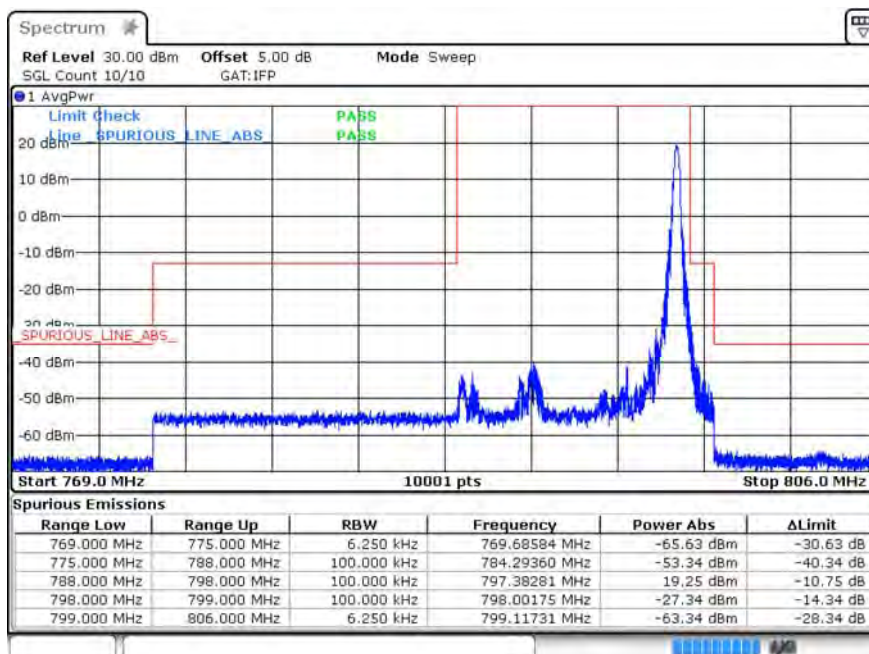

Date: 25 NOV.2020 06:21:19

LTE_B14_CH23330_10M__QPSK_50RB0

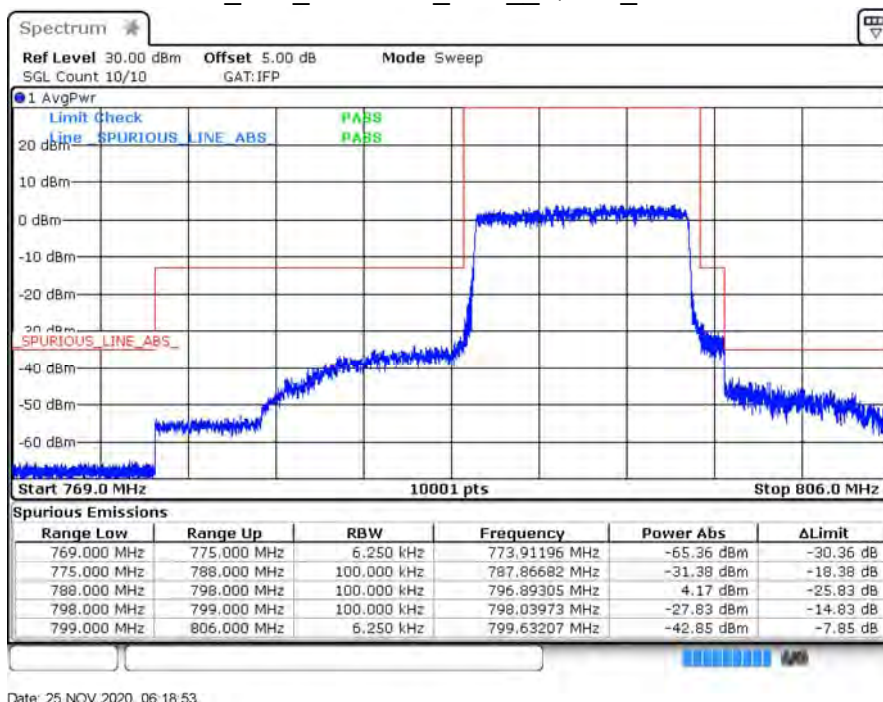

Note:

This report is prepared for Class II permissive change. The difference compared with original report no.: 2050962R-E3042110012-A is housing and software. The software changes as following:

- 1) Add LTE band 4, band 12, band 14, band 29 and close band 13 by software.
- 2) Close 5G FR2 band n261 by software.

According to above conditions, LTE band 12/ 14 and added EN-DC combination testing and Radiated Spurious Emissions (RSE) worst-case need to be performed and all data were verified to meet the requirements, and other test data refer to original report.

8. Frequency Stability

8.1. Test Setup

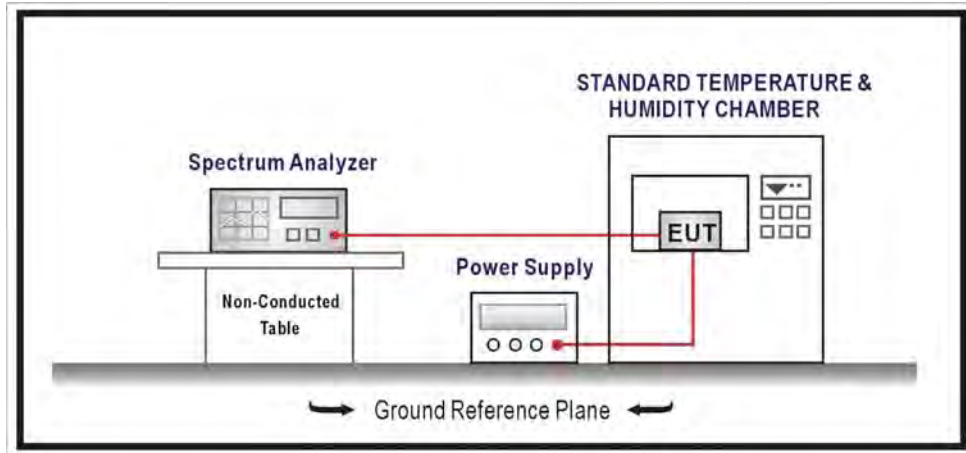

8.2. Test Procedure

Frequency Stability Under Temperature Variations:

The equipment under test was connected to an external AC or DC power supply and input rated voltage. RF output was connected to a frequency counter or spectrum analyzer via feed through attenuators. The EUT was placed inside the temperature chamber. Set the spectrum analyzer RBW low enough to obtain the desired frequency resolution and measure EUT 20°C operating frequency as reference frequency. Turn EUT off and set the chamber temperature to -30°C. After the temperature stabilized for approximately 30 minutes recorded the frequency. Repeat step measure with 10°C increased per stage until the highest temperature of +50°C reached.

Frequency Stability Under Voltage Variations:

Set chamber temperature to 20°C. Use a variable AC power supply / DC power source to power the EUT and set the voltage to rated voltage. Set the spectrum analyzer RBW low enough to obtain the desired frequency resolution and recorded the frequency. Reduce the input voltage to specify extreme voltage variation ($\pm 15\%$) and endpoint, record the maximum frequency change.

8.3. Test Method

KDB 971168 D01 Power Meas License Digital Systems v03 sub-clause 9
ANSI C63.26-2015 Sub-clause 5.6

8.4. Test Result

Product	5G CPE		
Test Item	Frequency Stability		
Test Mode	Mode 1: ENDC 12A_n2		
Date of Test	2020/11/30	Test Site	SR12-H
Temperature (°C)	23	Humidity (%RH)	69

LTE-Band 12

699.7MHz

Voltage

Voltage (Vdc)	Frequency Error(Hz)	Frequency Error(ppm)
22.0	3.90	0.0056
20.0	4.23	0.0060
18.0	3.11	0.0044

Temperature

TEMPERATURE	Frequency Error(Hz)	Frequency Error (ppm)
-30	4.01	0.0057
-20	3.61	0.0052
-10	3.30	0.0047
0	3.49	0.0050
10	3.44	0.0049
20	2.63	0.0038
30	3.20	0.0046
40	3.98	0.0057
50	3.04	0.0043
55	3.78	0.0054

LTE-Band 12

707.5MHz

Voltage

Voltage (Vdc)	Frequency Error(Hz)	Frequency Error(ppm)
22.0	3.41	0.0048
20.0	3.87	0.0055
18.0	3.89	0.0055

Temperature

TEMPERATURE	Frequency Error(Hz)	Frequency Error (ppm)
-30	4.73	0.0067
-20	3.48	0.0049
-10	3.36	0.0047
0	3.69	0.0052
10	2.92	0.0041
20	3.38	0.0048
30	2.95	0.0042
40	3.94	0.0056
50	3.09	0.0044
55	4.21	0.0060

LTE-Band 12

715.3MHz

Voltage

Voltage (Vdc)	Frequency Error(Hz)	Frequency Error(ppm)
22.0	3.40	0.0048
20.0	3.69	0.0052
18.0	2.21	0.0031

Temperature

TEMPERATURE	Frequency Error(Hz)	Frequency Error (ppm)
-30	2.88	0.0040
-20	3.34	0.0047
-10	3.13	0.0044
0	2.89	0.0040
10	3.52	0.0049
20	3.53	0.0049
30	3.65	0.0051
40	3.45	0.0048
50	2.81	0.0039
55	3.15	0.0044

LTE-Band 12

700.5MHz

Voltage

Voltage (Vdc)	Frequency Error(Hz)	Frequency Error(ppm)
22.0	2.75	0.0039
20.0	2.99	0.0043
18.0	2.90	0.0041

Temperature

TEMPERATURE	Frequency Error(Hz)	Frequency Error (ppm)
-30	1.67	0.0024
-20	2.71	0.0039
-10	2.85	0.0041
0	2.90	0.0041
10	2.36	0.0034
20	3.29	0.0047
30	2.75	0.0039
40	1.82	0.0026
50	2.90	0.0041
55	3.01	0.0043

LTE-Band 12

707.5MHz

Voltage

Voltage (Vdc)	Frequency Error(Hz)	Frequency Error(ppm)
22.0	2.21	0.0031
20.0	3.56	0.0050
18.0	3.34	0.0047

Temperature

TEMPERATURE	Frequency Error(Hz)	Frequency Error (ppm)
-30	2.57	0.0036
-20	2.86	0.0040
-10	2.60	0.0037
0	3.25	0.0046
10	2.66	0.0038
20	2.31	0.0033
30	2.79	0.0039
40	3.25	0.0046
50	3.69	0.0052
55	3.11	0.0044

LTE-Band 12

714.5MHz

Voltage

Voltage (Vdc)	Frequency Error(Hz)	Frequency Error(ppm)
22.0	2.68	0.0038
20.0	3.77	0.0053
18.0	3.67	0.0051

Temperature

TEMPERATURE	Frequency Error(Hz)	Frequency Error (ppm)
-30	2.99	0.0042
-20	3.56	0.0050
-10	3.52	0.0049
0	2.68	0.0038
10	3.09	0.0043
20	3.21	0.0045
30	3.70	0.0052
40	3.11	0.0044
50	3.37	0.0047
55	3.23	0.0045

LTE-Band 12

701.5MHz

Voltage

Voltage (Vdc)	Frequency Error(Hz)	Frequency Error(ppm)
22.0	3.30	0.0047
20.0	4.01	0.0057
18.0	3.51	0.0050

Temperature

TEMPERATURE	Frequency Error(Hz)	Frequency Error (ppm)
-30	3.79	0.0054
-20	3.15	0.0045
-10	3.45	0.0049
0	2.98	0.0042
10	3.35	0.0048
20	3.14	0.0045
30	3.46	0.0049
40	3.60	0.0051
50	4.31	0.0061
55	3.80	0.0054

LTE-Band 12

707.5MHz

Voltage

Voltage (Vdc)	Frequency Error(Hz)	Frequency Error(ppm)
22.0	3.40	0.0048
20.0	3.83	0.0054
18.0	3.58	0.0051

Temperature

TEMPERATURE	Frequency Error(Hz)	Frequency Error (ppm)
-30	4.34	0.0061
-20	2.85	0.0040
-10	3.59	0.0051
0	3.08	0.0044
10	3.08	0.0044
20	3.20	0.0045
30	3.38	0.0048
40	3.67	0.0052
50	3.47	0.0049
55	4.12	0.0058

LTE-Band 12

713.5MHz

Voltage

Voltage (Vdc)	Frequency Error(Hz)	Frequency Error(ppm)
22.0	2.14	0.0030
20.0	3.44	0.0048
18.0	3.03	0.0042

Temperature

TEMPERATURE	Frequency Error(Hz)	Frequency Error (ppm)
-30	2.67	0.0037
-20	2.63	0.0037
-10	3.57	0.0050
0	2.66	0.0037
10	1.84	0.0026
20	2.79	0.0039
30	2.48	0.0035
40	2.48	0.0035
50	2.14	0.0030
55	3.22	0.0045

LTE-Band 12

704MHz

Voltage

Voltage (Vdc)	Frequency Error(Hz)	Frequency Error(ppm)
22.0	2.14	0.0030
20.0	3.66	0.0052
18.0	2.56	0.0036

Temperature

TEMPERATURE	Frequency Error(Hz)	Frequency Error (ppm)
-30	3.47	0.0049
-20	1.98	0.0028
-10	3.02	0.0043
0	2.36	0.0034
10	2.91	0.0041
20	3.26	0.0046
30	3.12	0.0044
40	2.65	0.0038
50	2.52	0.0036
55	2.88	0.0041

LTE-Band 12

707.5MHz

Voltage

Voltage (Vdc)	Frequency Error(Hz)	Frequency Error(ppm)
22.0	2.59	0.0037
20.0	3.94	0.0056
18.0	3.22	0.0046

Temperature

TEMPERATURE	Frequency Error(Hz)	Frequency Error (ppm)
-30	2.39	0.0034
-20	2.30	0.0033
-10	2.99	0.0042
0	3.51	0.0050
10	3.88	0.0055
20	4.08	0.0058
30	3.82	0.0054
40	4.11	0.0058
50	3.21	0.0045
55	3.75	0.0053

LTE-Band 12

711MHz

Voltage

Voltage (Vdc)	Frequency Error(Hz)	Frequency Error(ppm)
22.0	4.83	0.0068
20.0	4.33	0.0061
18.0	3.61	0.0051

Temperature

TEMPERATURE	Frequency Error(Hz)	Frequency Error (ppm)
-30	4.18	0.0059
-20	4.28	0.0060
-10	3.78	0.0053
0	4.49	0.0063
10	4.28	0.0060
20	3.67	0.0052
30	4.32	0.0061
40	4.22	0.0059
50	4.87	0.0068
55	4.01	0.0056

Product	5G CPE		
Test Item	Frequency Stability		
Test Mode	Mode 2: ENDC 14A_n66		
Date of Test	2020/11/30	Test Site	SR12-H
Temperature (°C)	23	Humidity (%RH)	69

LTE-Band 14

790.5MHz

Voltage

Voltage (Vdc)	Frequency Error(Hz)	Frequency Error(ppm)
22.0	3.93	0.0050
20.0	4.22	0.0053
18.0	3.48	0.0044

Temperature

TEMPERATURE	Frequency Error(Hz)	Frequency Error (ppm)
-30	4.45	0.0056
-20	4.65	0.0059
-10	3.81	0.0048
0	2.84	0.0036
10	3.81	0.0048
20	3.73	0.0047
30	3.37	0.0043
40	3.90	0.0049
50	3.29	0.0042
55	4.11	0.0052

LTE-Band 14

793MHz

Voltage

Voltage (Vdc)	Frequency Error(Hz)	Frequency Error(ppm)
22.0	3.26	0.0041
20.0	2.87	0.0036
18.0	1.65	0.0021

Temperature

TEMPERATURE	Frequency Error(Hz)	Frequency Error (ppm)
-30	1.98	0.0025
-20	2.12	0.0027
-10	2.67	0.0034
0	2.35	0.0030
10	3.28	0.0041
20	2.71	0.0034
30	2.56	0.0032
40	2.47	0.0031
50	2.75	0.0035
55	3.09	0.0039

LTE-Band 14

795.5MHz

Voltage

Voltage (Vdc)	Frequency Error(Hz)	Frequency Error(ppm)
22.0	1.99	0.0025
20.0	3.02	0.0038
18.0	2.30	0.0029

Temperature

TEMPERATURE	Frequency Error(Hz)	Frequency Error (ppm)
-30	2.38	0.0030
-20	2.29	0.0029
-10	1.47	0.0018
0	2.50	0.0031
10	1.85	0.0023
20	3.00	0.0038
30	2.75	0.0035
40	2.44	0.0031
50	2.57	0.0032
55	2.75	0.0035

LTE-Band 14

793MHz

Voltage

Voltage (Vdc)	Frequency Error(Hz)	Frequency Error(ppm)
22.0	2.25	0.0028
20.0	2.97	0.0037
18.0	2.64	0.0033

Temperature

TEMPERATURE	Frequency Error(Hz)	Frequency Error (ppm)
-30	2.63	0.0033
-20	2.82	0.0036
-10	2.72	0.0034
0	2.21	0.0028
10	3.70	0.0047
20	3.24	0.0041
30	1.97	0.0025
40	2.00	0.0025
50	2.74	0.0035
55	3.56	0.0045

Note:

This report is prepared for Class II permissive change. The difference compared with original report no.: 2050962R-E3042110012-A is housing and software. The software changes as following:

- 1) Add LTE band 4, band 12, band 14, band 29 and close band 13 by software.
- 2) Close 5G FR2 band n261 by software.

According to above conditions, LTE band 12/ 14 and added EN-DC combination testing and Radiated Spurious Emissions (RSE) worst-case need to be performed and all data were verified to meet the requirements, and other test data refer to original report.