

ANNEX D: Co-location Measurements

1 OPERATIONAL STATES

Measurements were performed using the "LANCOM L-322agn dual Wireless" access point with two "AR5BHB116 2x2 802.11n PCIe" modules on the main PCB.

For the colocation tests, one wireless connection was established on WLAN channel 11 and the other connection on WLAN channel 149. Both WLAN modes were set on the WLAN mode with the worst case emissions, namely 802.11n with 20 MHz.

The configuration of the "LANCOM L-322agn dual Wireless" access point was set by the applicant.

The test setup for the colocation tests is described in Figure 1. The communication load is generated by ping flooding, using the settings below.

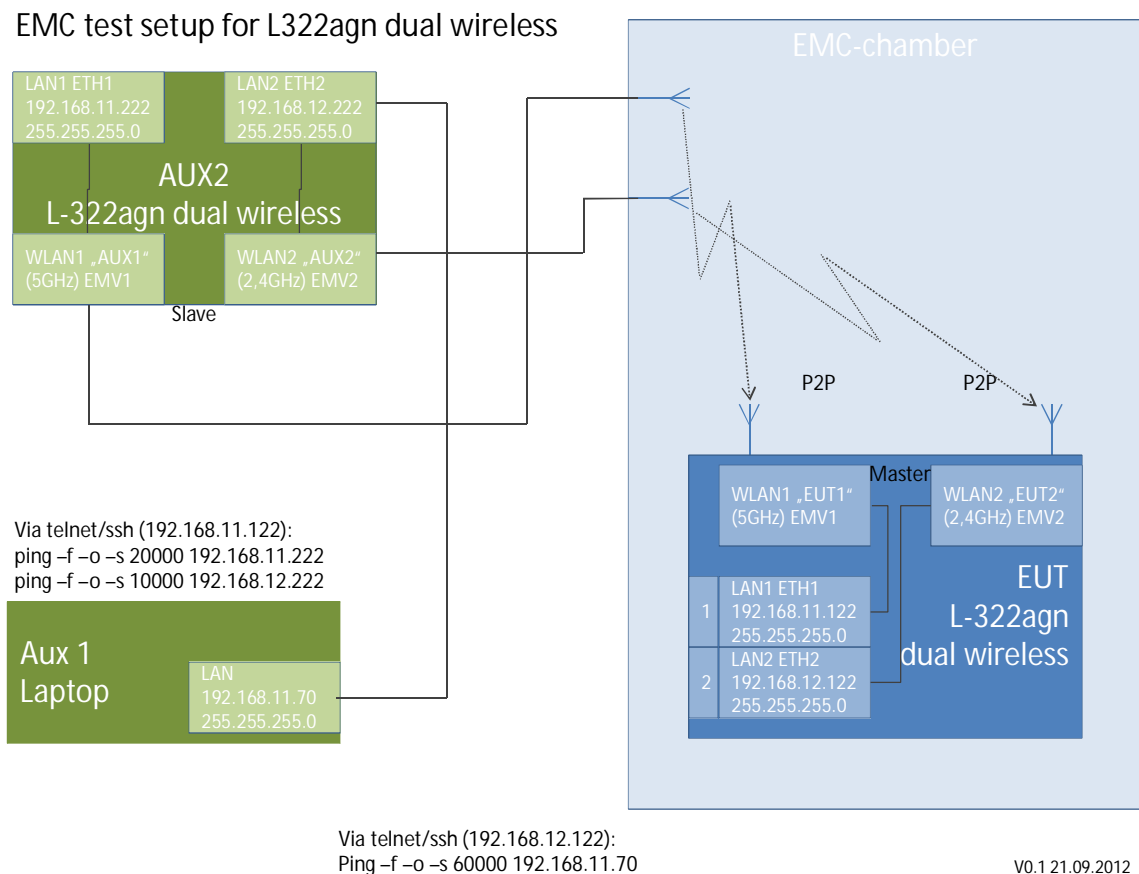
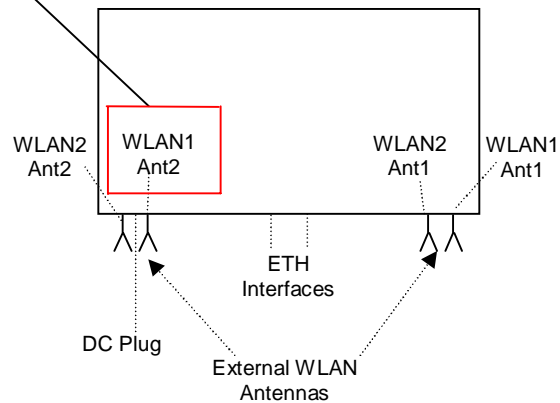

Figure 1 Test Setup for colocation tests

During the tests the test samples were powered with 12 V, provided by a 100-240 V AC/DC adapter, which was provided by the applicant.

Physical boundary of the EUT



For the radiated tests, the worst case positioning of the EUT was investigated through measurements. The WLAN router has two possible operating positions:

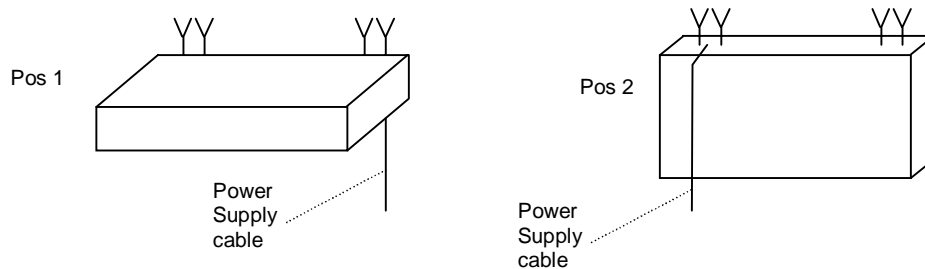

Position 1: Device lying horizontally
Position 2: Device mounted vertically

Preliminary tests were in the two positions, to find worst-case configuration and position. The radiated emission measurements were carried out in the orthogonal direction that emits the highest spurious emission levels. This was found to be Position 2.

2 ADDITIONAL INFORMATION

The firmware was changed to set the power settings according to chapter 2 of the applying test report.

3 OVERVIEW

Application	Frequency range [MHz]	FCC 47 CFR Part 15 section [2]	RSS 210, Issue 8 [4] or RSS-Gen, Issue 3 [5]	Status	Refer page
Radiated emissions	1,000 - 40,000	15.205 (a) 15.209 (a)	7.2.2 [5], 2.5 [4]	Passed	3 et seq.

4 TEST RESULTS

4.1 Maximum unwanted emissions

4.1.1 Method of measurement (radiated emissions)

The radiated emission measurement is subdivided into four stages.

- A preliminary measurement carried out in a fully anechoic chamber with a variable antenna distance and height in the frequency range 1 GHz to 110 GHz.
- A final measurement carried out in a fully anechoic chamber with a fixed antenna height in the frequency range 1 GHz to 110 GHz.

All measurements will be carried out with the EUT working on the middle of the assigned frequency band.

Preliminary and final measurement (1 GHz to 110 GHz)

This measurement will be performed in a fully anechoic chamber. Tabletop devices will set up on a non-conducting support with a size of 1 m by 1.5 m and a height of 80 cm. Floor-standing devices will be placed directly on the turntable/ground plane. The set up of the Equipment under test will be in accordance to ANSI C63.4-2009 [1].

Preliminary measurement (1 GHz to 110 GHz)

The frequency range will be divided into different sub ranges depending of the frequency range of the used horn antenna. The spectrum analyser set to MAX Hold mode and a resolution bandwidth of 100 kHz. The measurement will be performed in horizontal and vertical polarisation of the measuring antenna, the antenna close to the EUT and while moving the antenna over all sides of the EUT. With the spectrum analyser in CLEAR / WRITE mode the cone of the emission should be found and than the measuring distance will be set to 3 m with the receiving antenna moving in this cone of emission. At this position the final measurement will be carried out.

The resolution bandwidth of the EMI Receiver will be set to the following values:

Frequency range	Resolution bandwidth
1 GHz to 4 GHz	100 kHz
4 GHz to 12 GHz	100 kHz
12 GHz to 18 GHz	100 kHz
18 GHz to 26.5 GHz	100 kHz
26.5 GHz to 40 GHz	100 kHz
40 GHz to 60 GHz	100 kHz
50 GHz to 75 GHz	100 kHz
75 GHz to 110 GHz	100 kHz

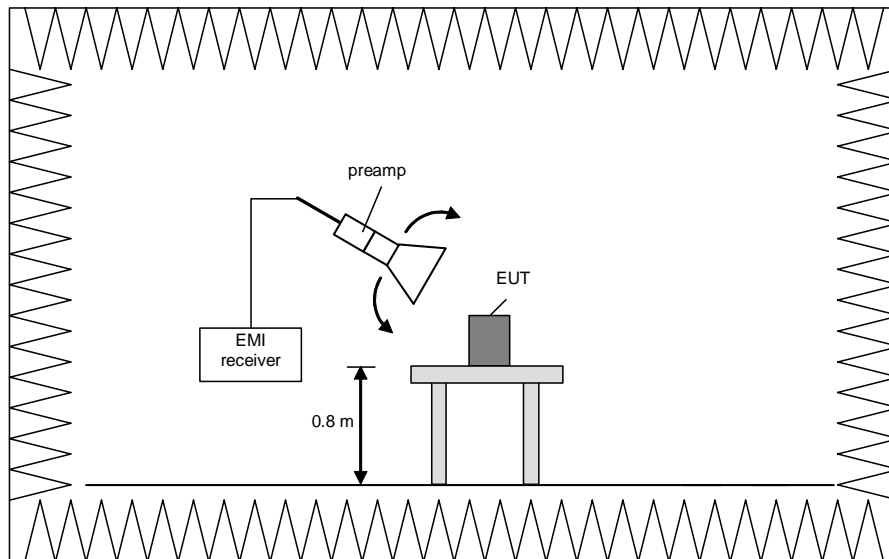

Final measurement (1 GHz to 110 GHz)

The frequency range will be divided into different sub ranges depending of the frequency range of the used horn antenna. The EMI Receiver set to peak and average mode and a resolution bandwidth of 1 MHz. The measurement will be performed in horizontal and vertical polarisation of the measuring antenna and while rotating the EUT in its vertical axis in the range of 0 ° to 360 ° in order to have the antenna inside the cone of radiation.

The resolution bandwidth of the EMI Receiver will be set to the following values:

Frequency range	Resolution bandwidth
1 GHz to 4 GHz	1 MHz
4 GHz to 12 GHz	1 MHz
12 GHz to 18 GHz	1 MHz
18 GHz to 26.5 GHz	1 MHz
26.5 GHz to 40 GHz	1 MHz
40 GHz to 60 GHz	1 MHz
50 GHz to 75 GHz	1 MHz
75 GHz to 110 GHz	1 MHz

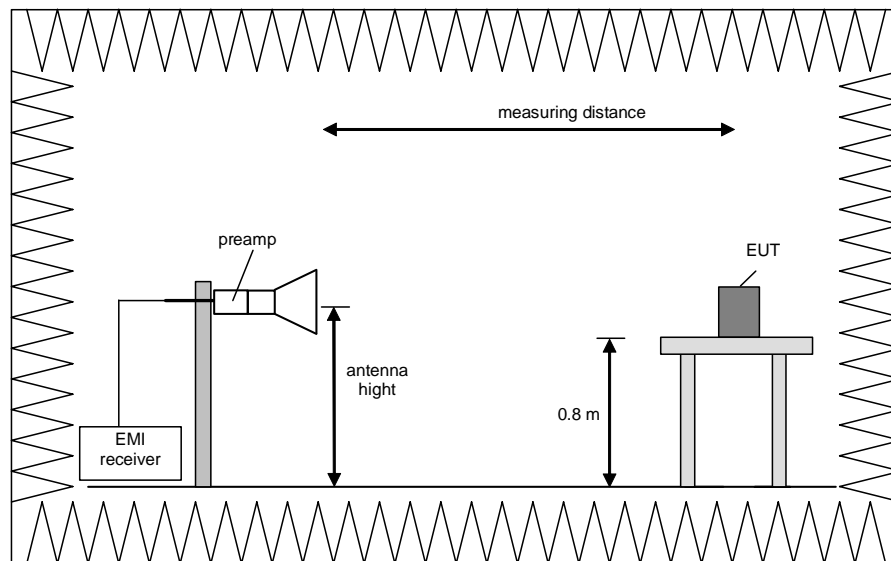

Procedure of measurement:

The measurements were performed in the frequency range 1 GHz to 4 GHz, 4 GHz to 12 GHz, 12 GHz to 18 GHz, 18 GHz to 26.5 GHz, 26.5 GHz to 40 GHz, 40 GHz to 60 GHz, 60 GHz to 75 GHz and 75 GHz to 110 GHz.

The following procedure will be used:

- 1) Monitor the frequency range at horizontal polarisation and move the antenna over all sides of the EUT (if necessary move the EUT to another orthogonal axis).
- 2) Change the antenna polarisation and repeat 1) with vertical polarisation.
- 3) Make a hardcopy of the spectrum.
- 4) Measure the frequency of the detected emissions with a lower span and resolution bandwidth to increase the accuracy and note the frequency value.
- 5) Change the analyser mode to Clear / Write and found the cone of emission.
- 6) Rotate and move the EUT, so that the measuring distance can be enlarged to 3 m and the antenna will be still inside the cone of emission.
- 7) Measure the level of the detected frequency with the correct resolution bandwidth, with the antenna polarisation and azimuth and the peak and average detector, which causes the maximum emission.
- 8) Repeat steps 1) to 7) for the next antenna spot if the EUT is larger than the antenna beamwidth.

Step 1) to 6) are defined as preliminary measurement.

4.1.2 Test results (radiated emissions)

4.1.2.1 Preliminary radiated emission measurement

Ambient temperature	20 °C	Relative humidity	30 %
---------------------	-------	-------------------	------

Position of EUT:	The EUT was set-up on a non-conducting table of a height of 0.8 m. The distance between EUT and antenna was 3 m.
Cable guide:	For detail information of test set-up and the cable guide refer to the pictures in annex A of the applying test report.
Test record:	All results are shown in the following.
Supply voltage:	During all measurements the EUT with 12 V via an AC/DC Adapter.
Remark:	The measurement was performed from 1 to 40 GHz, because no interferences from the two modules were expected at frequencies below 1 GHz.

Transmitter operates at the lower end of the assigned frequency band (n20-mode)

122165_179.wmf: Spurious emissions from 1 GHz to 4 GHz:

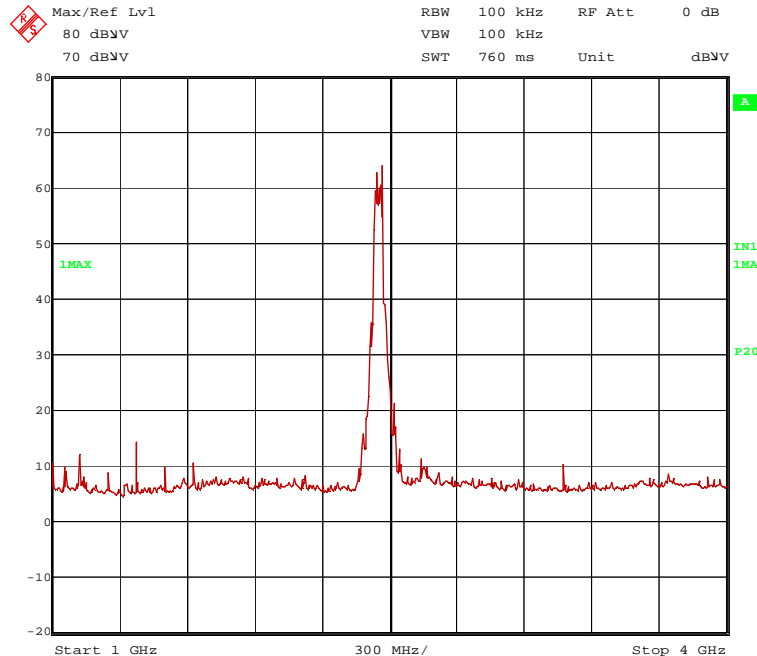

2165_180.wmf: Spurious emissions from 4 GHz to 12 GHz:

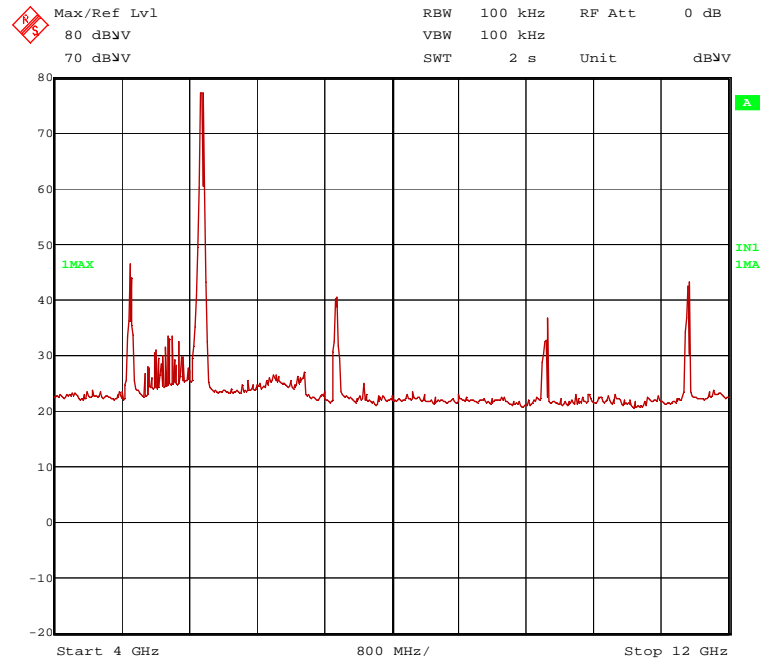

122165_182.wmf: Spurious emissions from 12 GHz to 18 GHz:

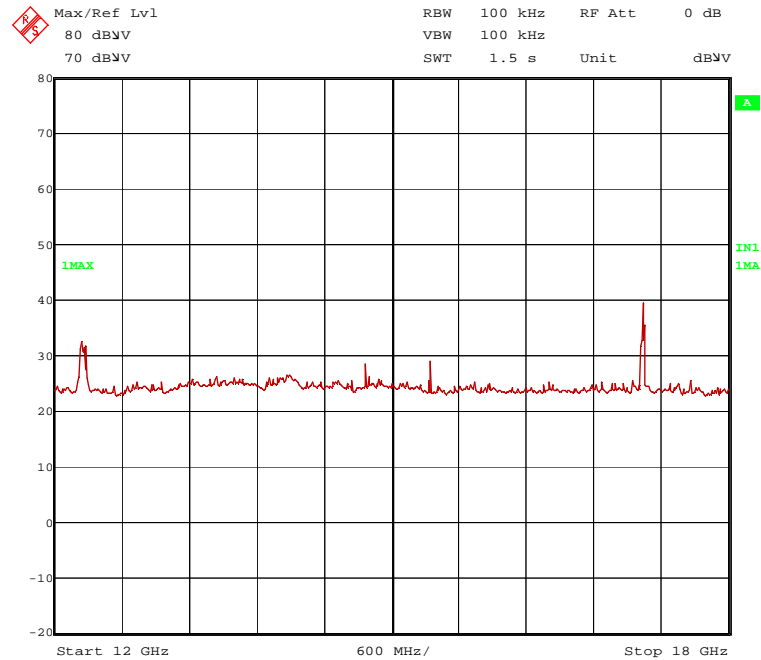

The following frequency was found inside the restricted bands during the preliminary radiated emission test:

- 1125 MHz, 1375 MHz, 4924 MHz, 5400 MHz, 7363 MHz, 11511 MHz, 12273 MHz, 19696 MHz, 23000 MHz.

¹¹

The following frequencies were found outside the restricted bands during the preliminary radiated emission test:

- 2467 MHz and 2642 MHz, 3269 MHz, 9813 MHz, 14772 MHz, 15347 MHz, 17272 MHz.

These frequencies have to be measured in a final measurement. The results are presented in the following.

4.1.2.2 Final radiated emission measurement (1 GHz to 40 GHz)

Ambient temperature	20 °C	Relative humidity	30 %
---------------------	-------	-------------------	------

Position of EUT: The EUT was set-up on a non-conducting table of a height of 0.8 m. The distance between EUT and antenna was 3 m.

Cable guide: For detail information of test set-up and the cable guide refer to the pictures in annex A of this test report.

Test record: All results are shown in the following.

Supply voltage: During all measurements the EUT with 12 V via an AC/DC Adapter.

Resolution bandwidth: For all measurements a resolution bandwidth of 1 MHz was used.

Transmitter operates at the lower end of the assigned frequency band (operation mode 1)

Result measured with the peak detector:

Frequency MHz	Corr. Value dB μ V/m	Limit dB μ V/m	Margin dB	Readings dB μ V	Antenna factor 1/m	Preamp dB	Cable loss dB	Height cm	Pol.	Restr. Band	Pos.
2467	99.6			67.4	28.5	0.0	3.7	150	Vert.	carrier	2
1125	45.2	74.0	28.8	18.1	24.6	0.0	2.5	150	Vert.	Yes	2
1375	46.9	74.0	27.1	19.0	25.0	0.0	2.9	150	Hor.	Yes	2
2642	54.2	79.6	25.4	21.5	28.6	0.0	4.1	150	Vert.	No	2
3269	51.5	79.6	28.1	16.3	30.9	0.0	4.3	150	Vert.	No	2
4924	66.6	74.0	7.4	54.0	32.9	25.6	5.3	150	Vert.	Yes	2
5400	53.1	74.0	20.9	39.0	33.8	25.4	5.7	150	Vert.	Yes	2
7363	71.9	74.0	2.1	53.4	36.3	24.6	6.8	150	Vert.	Yes	2
9813	69.0	79.6	10.6	47.6	37.3	23.9	8.0	150	Hor.	No	2
11511	73.1	74.0	0.9	49.7	38.8	24.1	8.7	150	Hor.	Yes	2
12273	46.9	74.0	27.1	36.6	33.7	25.9	2.5	150	Vert.	Yes	2
14772	43.5	79.6	36.1	34.0	33.7	26.7	2.5	150	Hor.	No	2
15347	43.6	79.6	36.0	34.4	33.7	27.0	2.5	150	Hor.	No	2
17272	54.3	79.6	25.3	45.2	33.9	27.3	2.5	150	Vert.	No	2
19696	45.0	74.0	29.0	43.7	37.1	38.3	2.5	150	Vert.	Yes	2
23000	43.1	74.0	30.9	41.8	37.2	38.4	2.5	150	Vert.	Yes	2
Measurement uncertainty							+2.2 dB / -3.6 dB				

Result measured with the average detector:

Frequency MHz	Corr. Value dBµV/m	Limit dBµV/m	Margin dB	Readings dBµV	Antenna factor 1/m	Preamp dB	Cable loss dB	Height cm	Pol.	Restr. Band	Pos.
2467	68.7			36.5	28.5	0.0	3.7	150	Vert.	carrier	2
1125	36.8	54.0	17.2	9.7	24.6	0.0	2.5	150	Vert.	Yes	2
1375	40.0	54.0	14.0	12.1	25.0	0.0	2.9	150	Hor.	Yes	2
2642	37.8	54.0	16.2	5.1	28.6	0.0	4.1	150	Vert.	No	2
3269	38.0	54.0	16.0	2.8	30.9	0.0	4.3	150	Vert.	No	2
4924	33.0	54.0	21.0	20.4	32.9	25.6	5.3	150	Vert.	Yes	2
5400	38.8	54.0	15.2	24.7	33.8	25.4	5.7	150	Vert.	Yes	2
7363	45.7	54.0	8.3	27.2	36.3	24.6	6.8	150	Vert.	Yes	2
9813	48.0	54.0	6.0	26.6	37.3	23.9	8.0	150	Hor.	No	2
11511	51.1	54.0	2.9	27.7	38.8	24.1	8.7	150	Hor.	Yes	2
12273	31.2	54.0	22.8	20.9	33.7	25.9	2.5	150	Vert.	Yes	2
14772	30.2	54.0	23.8	20.7	33.7	26.7	2.5	150	Hor.	No	2
15347	29.4	54.0	24.6	20.2	33.7	27.0	2.5	150	Hor.	No	2
17272	29.7	54.0	24.3	20.6	33.9	27.3	2.5	150	Vert.	No	2
19696	30.0	54.0	24.0	28.7	37.1	38.3	2.5	150	Vert.	Yes	2
23000	29.9	54.0	24.1	28.6	37.2	38.4	2.5	150	Vert.	Yes	2
Measurement uncertainty						+2.2 dB / -3.6 dB					

Test: Passed

TEST EQUIPMENT USED FOR THE TEST:

29, 31 – 37, 39 - 44, 46, 49 – 51, 55, 72, 73

5 TEST EQUIPMENT AND ANCILLARIES USED FOR TESTS

No.	Test equipment	Type	Manufacturer	Serial No.	PM. No.	Cal. Date	Cal. Due
1	Shielded chamber M47	-	Albatross Projects	B83117-C6439-T262 -	480662	Weekly verification (system cal.)	
2	EMI Receiver	ESIB 26	Rohde & Schwarz	1088.7490	481182	03/09/2012	03/2014
4	High pass filter	HR 0.13- 5ENN	FSY Microwave Inc.	DC 0109 SN 002	480340	Weekly verification (system cal.)	
14	Open area test site	-	Phoenix Test-Lab	-	480085	Weekly verification (system cal.)	
15	Measuring receiver	ESIB7	Rohde & Schwarz	100304	480521	02/15/2012	02/2014
16	Controller	HD100	Deisel	100/670	480139	-	-
17	Turntable	DS420HE	Deisel	420/620/80	480087	-	-
18	Antenna support	MA240-0	Inn-Co GmbH	MA240- 0/030/6600603	480086	-	-
19	Antenna	CBL6111 D	Chase	25761	480894	09/28/2011	09/2014
20	EMI Software	ES-K1	Rohde & Schwarz	-	480111	-	-
29	Fully anechoic chamber M20	-	Albatross Projects	B83107-E2439-T232	480303	Weekly verification (system cal.)	
30	Spectrum analyser	FSU	Rohde & Schwarz	200125	480956	02/15/2012	02/2014
31	Measuring receiver	ESI 40	Rohde & Schwarz	100064	480355	02/13/2012	02/2014
32	Controller	MCU	Maturo	MCU/043/971107	480832	-	-
33	Turntable	DS420HE	Deisel	420/620/80	480315	-	-
34	Antenna support	AS615P	Deisel	615/310	480187	-	-
35	Antenna	CBL6112 B	Chase	2688	480328	04/21/2011	04/2014
36	Antenna	3115 A	EMCO	9609-4918	480183	11/09/2011	11/2014
37	Standard Gain Horn 11.9 GHz – 18 GHz	18240-20	Flann Microwave	483	480294	Six month verification (system cal.)	
39	Standard Gain Horn 17.9 GHz – 26.7 GHz	20240-20	Flann Microwave	411	480297	Six month verification (system cal.)	
40	Standard Gain Horn Antenne 26.4 – 40.1 GHz	22240-20	Flann Microwave	469	480229	Six month verification (system cal.)	
41	RF-cable No. 3	Sucoflex 106B	Huber&Suhner	0563/6B / Kabel 3	480670	Weekly verification (system cal.)	
42	RF-cable No. 40	Sucoflex 106B	Huber&Suhner	0708/6B / Kabel 40	481330	Weekly verification (system cal.)	
43	RF-cable No. 30	RTK 081	Rosenberger	-	410141	Weekly verification (system cal.)	
44	RF-cable No. 31	RTK 081	Rosenberger	-	410142	Weekly verification (system cal.)	
46	RF-cable 1 m	KPS-1533- 400-KPS	Insulated Wire	-	480301	Six month verification (system cal.)	
49	Preamplifier	JS3- 00101200- 23-5A	Miteq	681851	480337	Six month verification (system cal.)	
50	Preamplifier	JS3- 12001800- 16-5A	Miteq	571667	480343	Six month verification (system cal.)	

51	Preamplifier	JS3-18002600-20-5A	Miteq	658697	480342	Six month verification (system cal.)	
55	Loop antenna	HFH2-Z2	Rohde & Schwarz	832609/014	480059	02/16/2012	02/2014
72	4 GHz High Pass Filter	WHKX4.0/18 G-8SS	Wainwright Instruments	1	480587	Weekly verification (system cal.)	
73	Single Control Unit	SCU	Maturo GmbH	SCU/006/971107	480831	Calibration not necessary	
80	Highpass Filter	H26G40G1	Microwave Circuits, Inc.	33471	480593	Six month verification (system cal.)	