

DHUR-AZ68 a/b/g/n/ac 2x2 Module User Manual

● **Revision History**

Version	Change history	Date
V1.0	Initial version	2017/11/02
V1.1	Modify pin define	2017/11/09

Contents

1. Product Introduction	4
1-1. Features	4
1-2. Interfaces and Power Supply	4
2. Product Photo	5
3. Product Specification	5
3-1. Electrical Specification	5
3-2. Chip Sequence	6
3-3. Wi-Fi Portion	6
3-4. BT Portion	12
4. Mechanical Drawing	13
5. Shielding cover Information	14
6. Connector Information	15
7. Coaxial IPEX Connector	16

Product Introduction

DHUR-AZ68 is an 802.11 a/b/g/n/ac WLAN/Bluetooth 5.0 combo module with USB interface based on MediaTek MT7668AUN chipset solution.

1-1. Features

- Dual band 2T2R support, IEEE 802.11a/b/g/n/ac + Bluetooth 5.0
- Support 20MHz, 40MHz and 80MHz bandwidth
- Support MU-MIMO RX, DBDC, STBC, LDPC, TX Beamformer, Rx Beamformee
- 2 on-board printed Wi-Fi antennas and 1 BT external antenna
- PCB 4 Layers with 46.5 x 40 x1.0 mm³

1-2. Interfaces and Power supply

- Power supply with VCC 5.0
- 10 pin wire to board
- USB 2.0 Interface

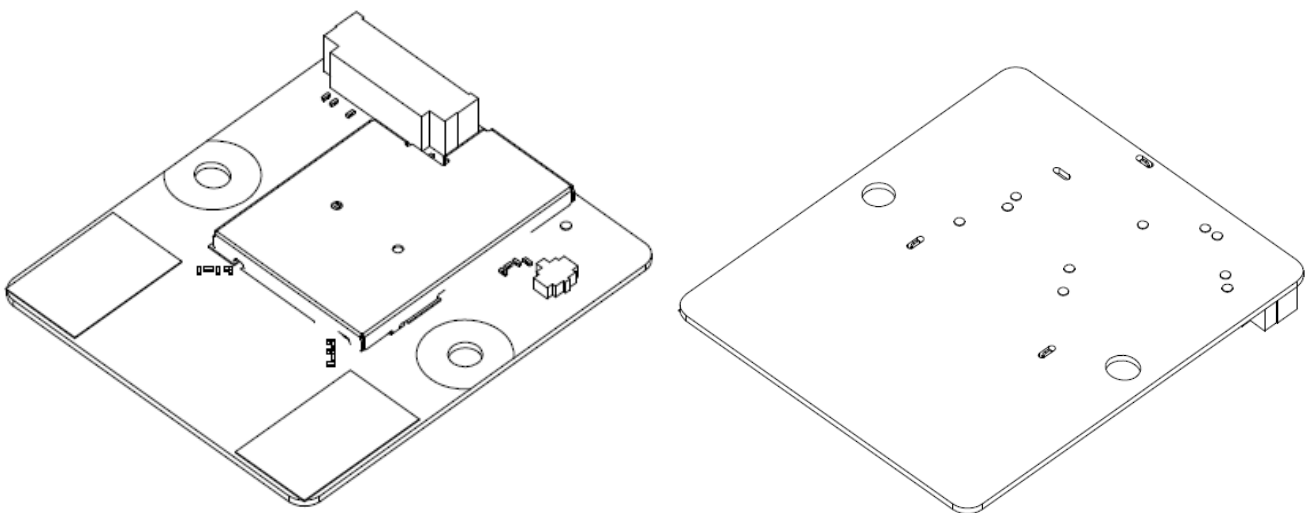

2 Product Photo

Top Side



Bottom Side

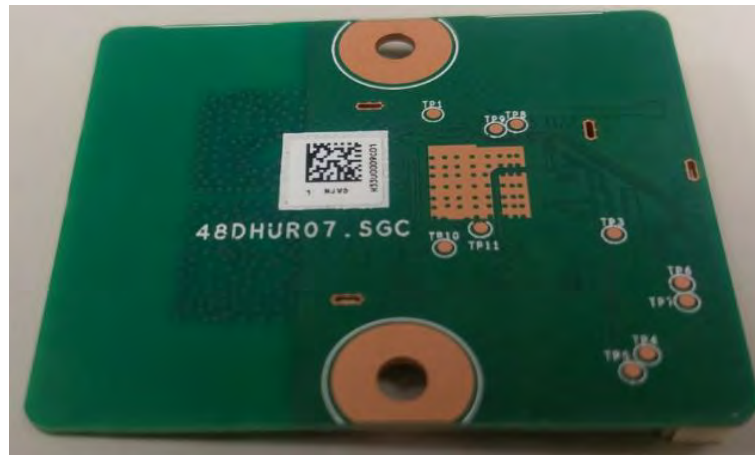

3. Product Specification

3-1. Electrical Specification

3-1-1. Absolute Maximum Ratings

Symbol (Board level)	Description	Min.	Max.	Units
5V	5V power supply	0	6.0	V
RESET	Controlled by SOC, GPIO input	-0.3	3.63	V
BT_WAKE_HOST	BT wake up host, GPIO output	-0.3	3.63	V
WoWLAN	Wake on Wireless LAN, GPIO output	-0.3	3.63	V
BT_IR	BT_IR signal from MT7668, GPIO output	-0.3	3.63	V
GPIO_X	BT_IR signal select, GPIO output	-0.3	3.63	V
H _{storage}	Storage humidity	5	85	%RH
T _{storage}	Storage temperature	-40	85	°C

3-1-2. Recommended Operating Conditions

Symbol (Board level)	Status	Description	Min.	Typ.	Max.	Units
5V	--	5V power supply	4.5	5.0	5.5	V
RESET	V _{IH}	3.3V Supply Voltage	2.97	3.3	3.63	V
WoWLAN	V _{OH}	Wake on wireless LAN	2.97	3.3	3.63	V
BT_WAKE_HOST	V _{IH}	BT wake up host	2.97	3.3	3.63	V
BT_IR	V _{OH}	BT_IR signal form MT7668	2.97	3.3	3.63	V
GPIO_X	V _{IH}	BT_IR signal select	2.97	3.3	3.63	V
T _{operating}	--	Operating temperature	-10	--	60	°C
H _{operating}	--	Operating humidity	5	--	95	%RH

3-2. Chip Sequence

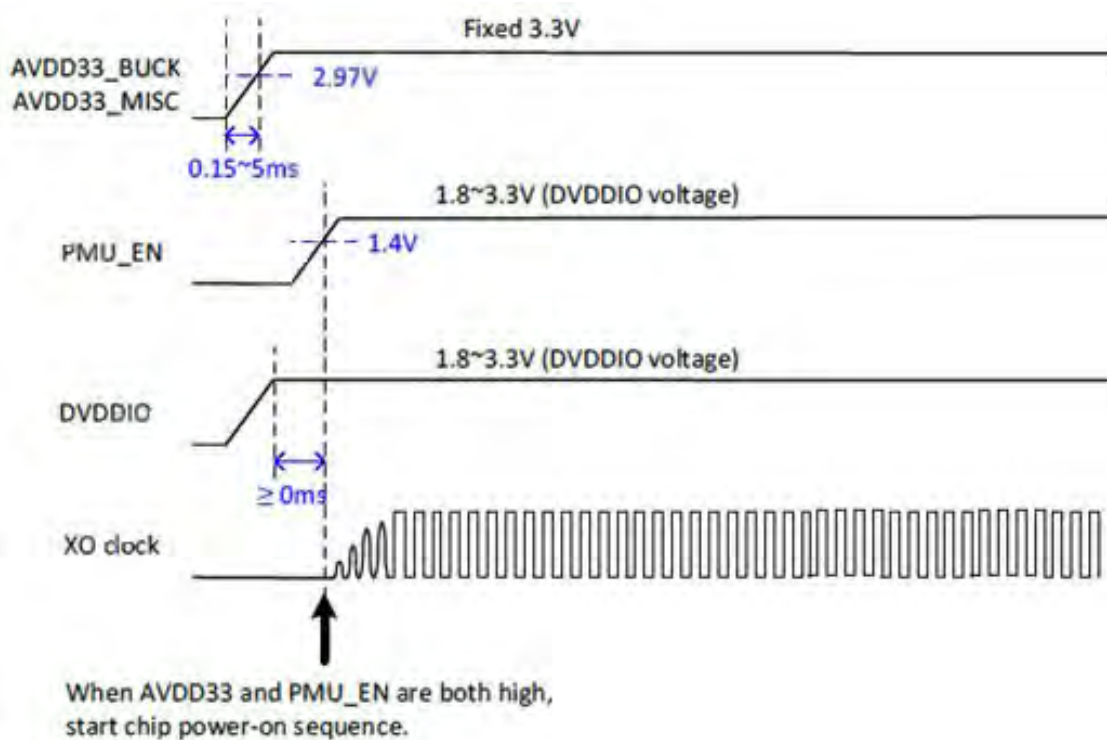

3-3. Wi-Fi Portion

Item	Key specifications
Main chipset	MT7668AUN
TX/RX	2T2R
Frequency range	2.400 ~ 2.497GHz, 5.15GHz ~ 5.85GHz

Modulation technique	<ul style="list-style-type: none"> ➤ 802.11 a/b/g DSSS (DBPSK, DQPSK, CCK) OFDM (BPSK, QPSK, 16-QAM, 64-QAM) DSSS (Direct Sequence Spread Spectrum) with DBPSK (Differential Binary Phase Shift Keying 1Mbps), DQPSK (Differential Quaternary Phase Shift Keying 2Mbps), and CCK (Complementary Code Keying 5.5&11Mbps), and OFDM (Orthogonal Frequency Division Multiplexing with BPSK for 6,9Mbps 、 QPSK for 12,18Mbps 、 16QAM for 24,36Mbps 、 64QAM for 48,54Mbps) ➤ 802.11n a/g OFDM (BPSK, QPSK, 16-QAM, 64-QAM) ➤ 802.11 ac OFDM (BPSK, QPSK, 16-QAM, 64-QAM,256-QAM) 																																																																															
Host interface	➤ USB2.0																																																																															
Power consumption @25 ° C	<table border="1" data-bbox="288 658 1350 1357"> <thead> <tr> <th rowspan="2">Current consumption</th> <th colspan="2" rowspan="2">standard</th> <th rowspan="2">Data Rate</th> <th colspan="2">Average.</th> <th rowspan="2">Units</th> </tr> <tr> <th>Typ.</th> <th>Max.</th> </tr> </thead> <tbody> <tr> <td>Sleep mode Radio off</td> <td colspan="2">--</td> <td>--</td> <td>1.5</td> <td>2.0</td> <td>mA</td> </tr> <tr> <td rowspan="6">WLAN Tx</td> <td rowspan="3">2.4G</td> <td>11b</td> <td>CCK-1M</td> <td>250</td> <td>280</td> <td rowspan="3">mA</td> </tr> <tr> <td>11g</td> <td>OFDM-7M</td> <td>350</td> <td>400</td> </tr> <tr> <td>11n</td> <td>HT20_MCS0</td> <td>350</td> <td>390</td> </tr> <tr> <td rowspan="3">5G</td> <td>11a</td> <td>OFDM-6M</td> <td>510</td> <td>630</td> <td rowspan="3">mA</td> </tr> <tr> <td>11n</td> <td>HT20-MCS0</td> <td>490</td> <td>590</td> </tr> <tr> <td>11ac</td> <td>VHT20-MCS0</td> <td>490</td> <td>580</td> </tr> <tr> <td rowspan="6">WLAN Rx</td> <td rowspan="3">2.4G</td> <td>11b</td> <td>CCK-1M</td> <td>85</td> <td>158</td> <td rowspan="3">mA</td> </tr> <tr> <td>11g</td> <td>OFDM-7M</td> <td>93</td> <td>158</td> </tr> <tr> <td>11n</td> <td>HT20_MCS0</td> <td>93</td> <td>158</td> </tr> <tr> <td rowspan="3">5G</td> <td>11a</td> <td>OFDM-6M</td> <td>100</td> <td>165</td> <td rowspan="3">mA</td> </tr> <tr> <td>11n</td> <td>HT20-MCS0</td> <td>100</td> <td>165</td> </tr> <tr> <td>11ac</td> <td>VHT20-MCS0</td> <td>101</td> <td>165</td> </tr> </tbody> </table>						Current consumption	standard		Data Rate	Average.		Units	Typ.	Max.	Sleep mode Radio off	--		--	1.5	2.0	mA	WLAN Tx	2.4G	11b	CCK-1M	250	280	mA	11g	OFDM-7M	350	400	11n	HT20_MCS0	350	390	5G	11a	OFDM-6M	510	630	mA	11n	HT20-MCS0	490	590	11ac	VHT20-MCS0	490	580	WLAN Rx	2.4G	11b	CCK-1M	85	158	mA	11g	OFDM-7M	93	158	11n	HT20_MCS0	93	158	5G	11a	OFDM-6M	100	165	mA	11n	HT20-MCS0	100	165	11ac	VHT20-MCS0	101	165
Current consumption	standard		Data Rate	Average.		Units																																																																										
				Typ.	Max.																																																																											
Sleep mode Radio off	--		--	1.5	2.0	mA																																																																										
WLAN Tx	2.4G	11b	CCK-1M	250	280	mA																																																																										
		11g	OFDM-7M	350	400																																																																											
		11n	HT20_MCS0	350	390																																																																											
	5G	11a	OFDM-6M	510	630	mA																																																																										
		11n	HT20-MCS0	490	590																																																																											
		11ac	VHT20-MCS0	490	580																																																																											
WLAN Rx	2.4G	11b	CCK-1M	85	158	mA																																																																										
		11g	OFDM-7M	93	158																																																																											
		11n	HT20_MCS0	93	158																																																																											
	5G	11a	OFDM-6M	100	165	mA																																																																										
		11n	HT20-MCS0	100	165																																																																											
		11ac	VHT20-MCS0	101	165																																																																											

Output power (per chain; 2.4G tolerance +/-2.5 dB, 5G tolerance +/-3,0dB)	➤ 802.11a								
	Test Frequencies	6-36_Target	48_Target	54_Target					
	5180	15.5	15.5	14.5					
	5320	15.5	15.5	14.5					
	5500	15.5	15.5	14.5					
	5600	15.5	15.5	14.5					
	5700	15.5	15.5	14.5					
	5825	15.5	15.5	14.5					
	➤ 802.11b								
	Test Frequencies	1/2_Target	5.5_Target	11_Target					
	2412	18.5	18	18					
	2472	18.5	18	18					
	2484	18.5	18	18					
	➤ 802.11g								
	Test Frequencies	6-12_Target	18_Target	24_Target	36_Target	48_Target	54_Target		
	2412	16.5	16.5	16.5	16.5	15.5	15.5		
	2442	16.5	16.5	16.5	16.5	15.5	15.5		
	2472	16.5	16.5	16.5	16.5	15.5	15.5		
	➤ 802.11n								
	Freq. Range: HT20								
	Test Freq	MCS 0/8	MCS 1/9	MCS 2/10	MCS 3/11	MCS 4/12	MCS 5/13	MCS 6/14	MCS 7/15
	5180	14.5	14.5	14.5	14.5	14.5	14.5	14.5	14.5
	5240	14.5	14.5	14.5	14.5	14.5	14.5	14.5	14.5
	5320	14.5	14.5	14.5	14.5	14.5	14.5	14.5	14.5
	5500	14.5	14.5	14.5	14.5	14.5	14.5	14.5	14.5
	5700	14.5	14.5	14.5	14.5	14.5	14.5	14.5	14.5
	5745	14.5	14.5	14.5	14.5	14.5	14.5	14.5	14.5
	5825	14.5	14.5	14.5	14.5	14.5	14.5	14.5	14.5
	Freq. Range: HT40								
	Test Freq	MCS 0/8	MCS 1/9	MCS 2/10	MCS 3/11	MCS 4/12	MCS 5/13	MCS 6/14	MCS 7/15
5190	14	14	14	14	14	14	14	14.5	
5230	14	14	14	14	14	14	14	14.5	
5270	14	14	14	14	14	14	14	14.5	
5510	14	14	14	14	14	14	14	14.5	
5670	14	14	14	14	14	14	14	14.5	
5755	14	14	14	14	14	14	14	14.5	
5795	14	14	14	14	14	14	14	14.5	
Freq. Range: HT20									
Test Freq	MCS 0/8	MCS 1/9	MCS 2/10	MCS 3/11	MCS 4/12	MCS 5/13	MCS 6/14	MCS 7/15	
2412	15.5	15.5	15.5	15.5	15.5	15.5	15.5	15.5	
2437	15.5	15.5	15.5	15.5	15.5	15.5	15.5	15.5	
2472	15.5	15.5	15.5	15.5	15.5	15.5	15.5	15.5	
Freq. Range: HT40									
Test Freq	MCS 0/8	MCS 1/9	MCS 2/10	MCS 3/11	MCS 4/12	MCS 5/13	MCS 6/14	MCS 7/15	
2412	15.5	15.5	15.5	15.5	15.5	15.5	15.5	15.5	
2437	15.5	15.5	15.5	15.5	15.5	15.5	15.5	15.5	
2472	15.5	15.5	15.5	15.5	15.5	15.5	15.5	15.5	

	<p>➤ 802.11ac Freq. Range: VHT20</p> <table border="1"> <thead> <tr> <th>Test Freq</th> <th>MCS 0</th> <th>MCS 1</th> <th>MCS 2</th> <th>MCS 3</th> <th>MCS 4</th> <th>MCS 5</th> <th>MCS 6</th> <th>MCS 7</th> <th>MCS 8</th> </tr> </thead> <tbody> <tr><td>5180</td><td>14.5</td><td>14.5</td><td>14.5</td><td>14.5</td><td>14.5</td><td>14.5</td><td>14.5</td><td>14.5</td><td>14.5</td></tr> <tr><td>5240</td><td>14.5</td><td>14.5</td><td>14.5</td><td>14.5</td><td>14.5</td><td>14.5</td><td>14.5</td><td>14.5</td><td>14.5</td></tr> <tr><td>5320</td><td>14.5</td><td>14.5</td><td>14.5</td><td>14.5</td><td>14.5</td><td>14.5</td><td>14.5</td><td>14.5</td><td>14.5</td></tr> <tr><td>5500</td><td>14.5</td><td>14.5</td><td>14.5</td><td>14.5</td><td>14.5</td><td>14.5</td><td>14.5</td><td>14.5</td><td>14.5</td></tr> <tr><td>5700</td><td>14.5</td><td>14.5</td><td>14.5</td><td>14.5</td><td>14.5</td><td>14.5</td><td>14.5</td><td>14.5</td><td>14.5</td></tr> <tr><td>5745</td><td>14.5</td><td>14.5</td><td>14.5</td><td>14.5</td><td>14.5</td><td>14.5</td><td>14.5</td><td>14.5</td><td>14.5</td></tr> <tr><td>5825</td><td>14.5</td><td>14.5</td><td>14.5</td><td>14.5</td><td>14.5</td><td>14.5</td><td>14.5</td><td>14.5</td><td>14.5</td></tr> </tbody> </table> <p>Freq. Range: VHT40</p> <table border="1"> <thead> <tr> <th>Test Freq</th> <th>MCS 0</th> <th>MCS 1</th> <th>MCS 2</th> <th>MCS 3</th> <th>MCS 4</th> <th>MCS 5</th> <th>MCS 6</th> <th>MCS 7</th> <th>MCS 8</th> <th>MCS 9</th> </tr> </thead> <tbody> <tr><td>5210</td><td>13.5</td><td>13.5</td><td>13.5</td><td>13.5</td><td>13.5</td><td>13.5</td><td>13.5</td><td>13.5</td><td>13.5</td><td>13.5</td></tr> <tr><td>5290</td><td>13.5</td><td>13.5</td><td>13.5</td><td>13.5</td><td>13.5</td><td>13.5</td><td>13.5</td><td>13.5</td><td>13.5</td><td>13.5</td></tr> <tr><td>5530</td><td>13.5</td><td>13.5</td><td>13.5</td><td>13.5</td><td>13.5</td><td>13.5</td><td>13.5</td><td>13.5</td><td>13.5</td><td>13.5</td></tr> <tr><td>5610</td><td>13.5</td><td>13.5</td><td>13.5</td><td>13.5</td><td>13.5</td><td>13.5</td><td>13.5</td><td>13.5</td><td>13.5</td><td>13.5</td></tr> <tr><td>5690</td><td>13.5</td><td>13.5</td><td>13.5</td><td>13.5</td><td>13.5</td><td>13.5</td><td>13.5</td><td>13.5</td><td>13.5</td><td>13.5</td></tr> <tr><td>5775</td><td>13.5</td><td>13.5</td><td>13.5</td><td>13.5</td><td>13.5</td><td>13.5</td><td>13.5</td><td>13.5</td><td>13.5</td><td>13.5</td></tr> </tbody> </table> <p>Freq. Range: VHT80</p> <table border="1"> <thead> <tr> <th>Test Freq</th> <th>MCS 0</th> <th>MCS 1</th> <th>MCS 2</th> <th>MCS 3</th> <th>MCS 4</th> <th>MCS 5</th> <th>MCS 6</th> <th>MCS 7</th> <th>MCS 8</th> <th>MCS 9</th> </tr> </thead> <tbody> <tr><td>5210</td><td>13.5</td><td>13.5</td><td>13.5</td><td>13.5</td><td>13.5</td><td>13.5</td><td>13.5</td><td>13.5</td><td>13.5</td><td>13.5</td></tr> <tr><td>5290</td><td>13.5</td><td>13.5</td><td>13.5</td><td>13.5</td><td>13.5</td><td>13.5</td><td>13.5</td><td>13.5</td><td>13.5</td><td>13.5</td></tr> <tr><td>5530</td><td>13.5</td><td>13.5</td><td>13.5</td><td>13.5</td><td>13.5</td><td>13.5</td><td>13.5</td><td>13.5</td><td>13.5</td><td>13.5</td></tr> <tr><td>5610</td><td>13.5</td><td>13.5</td><td>13.5</td><td>13.5</td><td>13.5</td><td>13.5</td><td>13.5</td><td>13.5</td><td>13.5</td><td>13.5</td></tr> <tr><td>5690</td><td>13.5</td><td>13.5</td><td>13.5</td><td>13.5</td><td>13.5</td><td>13.5</td><td>13.5</td><td>13.5</td><td>13.5</td><td>13.5</td></tr> <tr><td>5775</td><td>13.5</td><td>13.5</td><td>13.5</td><td>13.5</td><td>13.5</td><td>13.5</td><td>13.5</td><td>13.5</td><td>13.5</td><td>13.5</td></tr> </tbody> </table>										Test Freq	MCS 0	MCS 1	MCS 2	MCS 3	MCS 4	MCS 5	MCS 6	MCS 7	MCS 8	5180	14.5	14.5	14.5	14.5	14.5	14.5	14.5	14.5	14.5	5240	14.5	14.5	14.5	14.5	14.5	14.5	14.5	14.5	14.5	5320	14.5	14.5	14.5	14.5	14.5	14.5	14.5	14.5	14.5	5500	14.5	14.5	14.5	14.5	14.5	14.5	14.5	14.5	14.5	5700	14.5	14.5	14.5	14.5	14.5	14.5	14.5	14.5	14.5	5745	14.5	14.5	14.5	14.5	14.5	14.5	14.5	14.5	14.5	5825	14.5	14.5	14.5	14.5	14.5	14.5	14.5	14.5	14.5	Test Freq	MCS 0	MCS 1	MCS 2	MCS 3	MCS 4	MCS 5	MCS 6	MCS 7	MCS 8	MCS 9	5210	13.5	13.5	13.5	13.5	13.5	13.5	13.5	13.5	13.5	13.5	5290	13.5	13.5	13.5	13.5	13.5	13.5	13.5	13.5	13.5	13.5	5530	13.5	13.5	13.5	13.5	13.5	13.5	13.5	13.5	13.5	13.5	5610	13.5	13.5	13.5	13.5	13.5	13.5	13.5	13.5	13.5	13.5	5690	13.5	13.5	13.5	13.5	13.5	13.5	13.5	13.5	13.5	13.5	5775	13.5	13.5	13.5	13.5	13.5	13.5	13.5	13.5	13.5	13.5	Test Freq	MCS 0	MCS 1	MCS 2	MCS 3	MCS 4	MCS 5	MCS 6	MCS 7	MCS 8	MCS 9	5210	13.5	13.5	13.5	13.5	13.5	13.5	13.5	13.5	13.5	13.5	5290	13.5	13.5	13.5	13.5	13.5	13.5	13.5	13.5	13.5	13.5	5530	13.5	13.5	13.5	13.5	13.5	13.5	13.5	13.5	13.5	13.5	5610	13.5	13.5	13.5	13.5	13.5	13.5	13.5	13.5	13.5	13.5	5690	13.5	13.5	13.5	13.5	13.5	13.5	13.5	13.5	13.5	13.5	5775	13.5	13.5	13.5	13.5	13.5	13.5	13.5	13.5	13.5	13.5
	Test Freq	MCS 0	MCS 1	MCS 2	MCS 3	MCS 4	MCS 5	MCS 6	MCS 7	MCS 8																																																																																																																																																																																																																																										
	5180	14.5	14.5	14.5	14.5	14.5	14.5	14.5	14.5	14.5																																																																																																																																																																																																																																										
	5240	14.5	14.5	14.5	14.5	14.5	14.5	14.5	14.5	14.5																																																																																																																																																																																																																																										
5320	14.5	14.5	14.5	14.5	14.5	14.5	14.5	14.5	14.5																																																																																																																																																																																																																																											
5500	14.5	14.5	14.5	14.5	14.5	14.5	14.5	14.5	14.5																																																																																																																																																																																																																																											
5700	14.5	14.5	14.5	14.5	14.5	14.5	14.5	14.5	14.5																																																																																																																																																																																																																																											
5745	14.5	14.5	14.5	14.5	14.5	14.5	14.5	14.5	14.5																																																																																																																																																																																																																																											
5825	14.5	14.5	14.5	14.5	14.5	14.5	14.5	14.5	14.5																																																																																																																																																																																																																																											
Test Freq	MCS 0	MCS 1	MCS 2	MCS 3	MCS 4	MCS 5	MCS 6	MCS 7	MCS 8	MCS 9																																																																																																																																																																																																																																										
5210	13.5	13.5	13.5	13.5	13.5	13.5	13.5	13.5	13.5	13.5																																																																																																																																																																																																																																										
5290	13.5	13.5	13.5	13.5	13.5	13.5	13.5	13.5	13.5	13.5																																																																																																																																																																																																																																										
5530	13.5	13.5	13.5	13.5	13.5	13.5	13.5	13.5	13.5	13.5																																																																																																																																																																																																																																										
5610	13.5	13.5	13.5	13.5	13.5	13.5	13.5	13.5	13.5	13.5																																																																																																																																																																																																																																										
5690	13.5	13.5	13.5	13.5	13.5	13.5	13.5	13.5	13.5	13.5																																																																																																																																																																																																																																										
5775	13.5	13.5	13.5	13.5	13.5	13.5	13.5	13.5	13.5	13.5																																																																																																																																																																																																																																										
Test Freq	MCS 0	MCS 1	MCS 2	MCS 3	MCS 4	MCS 5	MCS 6	MCS 7	MCS 8	MCS 9																																																																																																																																																																																																																																										
5210	13.5	13.5	13.5	13.5	13.5	13.5	13.5	13.5	13.5	13.5																																																																																																																																																																																																																																										
5290	13.5	13.5	13.5	13.5	13.5	13.5	13.5	13.5	13.5	13.5																																																																																																																																																																																																																																										
5530	13.5	13.5	13.5	13.5	13.5	13.5	13.5	13.5	13.5	13.5																																																																																																																																																																																																																																										
5610	13.5	13.5	13.5	13.5	13.5	13.5	13.5	13.5	13.5	13.5																																																																																																																																																																																																																																										
5690	13.5	13.5	13.5	13.5	13.5	13.5	13.5	13.5	13.5	13.5																																																																																																																																																																																																																																										
5775	13.5	13.5	13.5	13.5	13.5	13.5	13.5	13.5	13.5	13.5																																																																																																																																																																																																																																										
Sensitivity	<p>➤ 802.11a</p> <table border="1"> <thead> <tr> <th>Modulation</th> <th>Code Rate</th> <th>IEEE Spec (1Rx dBm)</th> <th>Typical (1Rx dBm)</th> </tr> </thead> <tbody> <tr><td>BPSK</td><td>1/2</td><td>-82</td><td>-89</td></tr> <tr><td>BPSK</td><td>3/4</td><td>-81</td><td>-88</td></tr> <tr><td>QPSK</td><td>1/2</td><td>-79</td><td>-87</td></tr> <tr><td>QPSK</td><td>3/4</td><td>-77</td><td>-85</td></tr> <tr><td>16-QAM</td><td>1/2</td><td>-74</td><td>-82</td></tr> <tr><td>16-QAM</td><td>3/4</td><td>-70</td><td>-78</td></tr> <tr><td>64-QAM</td><td>2/3</td><td>-66</td><td>-74</td></tr> <tr><td>64-QAM</td><td>3/4</td><td>-65</td><td>-67</td></tr> </tbody> </table> <p>➤ 802.11b</p> <table border="1"> <thead> <tr> <th>Modulation</th> <th>Code Rate</th> <th>IEEE Spec (1Rx dBm)</th> <th>Typical (1Rx dBm)</th> </tr> </thead> <tbody> <tr><td>DBPSK</td><td>-</td><td>not specified</td><td>-98</td></tr> <tr><td>DQPSK</td><td>-</td><td>not specified</td><td>-95</td></tr> <tr><td>DQPSK</td><td>CCK</td><td>not specified</td><td>-90</td></tr> <tr><td>DQPSK</td><td>CCK</td><td>not specified</td><td>-90</td></tr> </tbody> </table> <p>➤ 802.11g</p> <table border="1"> <thead> <tr> <th>Modulation</th> <th>Code Rate</th> <th>IEEE Spec (1Rx dBm)</th> <th>Typical (1Rx dBm)</th> </tr> </thead> <tbody> <tr><td>BPSK</td><td>1/2</td><td>-82</td><td>-89</td></tr> <tr><td>BPSK</td><td>3/4</td><td>-81</td><td>-88</td></tr> <tr><td>QPSK</td><td>1/2</td><td>-79</td><td>-86</td></tr> <tr><td>QPSK</td><td>3/4</td><td>-77</td><td>-84</td></tr> <tr><td>16-QAM</td><td>1/2</td><td>-74</td><td>-81</td></tr> <tr><td>16-QAM</td><td>3/4</td><td>-70</td><td>-78</td></tr> <tr><td>64-QAM</td><td>2/3</td><td>-66</td><td>-74</td></tr> <tr><td>64-QAM</td><td>3/4</td><td>-65</td><td>-73</td></tr> </tbody> </table>										Modulation	Code Rate	IEEE Spec (1Rx dBm)	Typical (1Rx dBm)	BPSK	1/2	-82	-89	BPSK	3/4	-81	-88	QPSK	1/2	-79	-87	QPSK	3/4	-77	-85	16-QAM	1/2	-74	-82	16-QAM	3/4	-70	-78	64-QAM	2/3	-66	-74	64-QAM	3/4	-65	-67	Modulation	Code Rate	IEEE Spec (1Rx dBm)	Typical (1Rx dBm)	DBPSK	-	not specified	-98	DQPSK	-	not specified	-95	DQPSK	CCK	not specified	-90	DQPSK	CCK	not specified	-90	Modulation	Code Rate	IEEE Spec (1Rx dBm)	Typical (1Rx dBm)	BPSK	1/2	-82	-89	BPSK	3/4	-81	-88	QPSK	1/2	-79	-86	QPSK	3/4	-77	-84	16-QAM	1/2	-74	-81	16-QAM	3/4	-70	-78	64-QAM	2/3	-66	-74	64-QAM	3/4	-65	-73																																																																																																																																														
	Modulation	Code Rate	IEEE Spec (1Rx dBm)	Typical (1Rx dBm)																																																																																																																																																																																																																																																
BPSK	1/2	-82	-89																																																																																																																																																																																																																																																	
BPSK	3/4	-81	-88																																																																																																																																																																																																																																																	
QPSK	1/2	-79	-87																																																																																																																																																																																																																																																	
QPSK	3/4	-77	-85																																																																																																																																																																																																																																																	
16-QAM	1/2	-74	-82																																																																																																																																																																																																																																																	
16-QAM	3/4	-70	-78																																																																																																																																																																																																																																																	
64-QAM	2/3	-66	-74																																																																																																																																																																																																																																																	
64-QAM	3/4	-65	-67																																																																																																																																																																																																																																																	
Modulation	Code Rate	IEEE Spec (1Rx dBm)	Typical (1Rx dBm)																																																																																																																																																																																																																																																	
DBPSK	-	not specified	-98																																																																																																																																																																																																																																																	
DQPSK	-	not specified	-95																																																																																																																																																																																																																																																	
DQPSK	CCK	not specified	-90																																																																																																																																																																																																																																																	
DQPSK	CCK	not specified	-90																																																																																																																																																																																																																																																	
Modulation	Code Rate	IEEE Spec (1Rx dBm)	Typical (1Rx dBm)																																																																																																																																																																																																																																																	
BPSK	1/2	-82	-89																																																																																																																																																																																																																																																	
BPSK	3/4	-81	-88																																																																																																																																																																																																																																																	
QPSK	1/2	-79	-86																																																																																																																																																																																																																																																	
QPSK	3/4	-77	-84																																																																																																																																																																																																																																																	
16-QAM	1/2	-74	-81																																																																																																																																																																																																																																																	
16-QAM	3/4	-70	-78																																																																																																																																																																																																																																																	
64-QAM	2/3	-66	-74																																																																																																																																																																																																																																																	
64-QAM	3/4	-65	-73																																																																																																																																																																																																																																																	

➤ 802.11ng (HT20)

Modulation	Code Rate	IEEE Spec (1Rx dBm)	Typical (1Rx dBm)
(MCS0) BPSK	1/2	-82	-90
(MCS1) QPSK	1/2	-79	-87
(MCS2) QPSK	3/4	-77	-85
(MCS3) 16-QAM	1/2	-74	-82
(MCS4) 16-QAM	3/4	-70	-80
(MCS5) 64-QAM	2/3	-66	-75
(MCS6) 64-QAM	3/4	-65	-74
(MCS7) 64-QAM	5/6	-64	-67

(HT40)

Modulation	Code Rate	IEEE Spec (1Rx dBm)	Typical (1Rx dBm)
(MCS0) BPSK	1/2	-79	-88
(MCS1) QPSK	1/2	-76	-86
(MCS2) QPSK	3/4	-74	-84
(MCS3) 16-QAM	1/2	-71	-81
(MCS4) 16-QAM	3/4	-67	-78
(MCS5) 64-QAM	2/3	-63	-74
(MCS6) 64-QAM	3/4	-62	-69
(MCS7) 64-QAM	5/6	-61	-65

➤ 802.11na (HT20)

Modulation	Code Rate	IEEE Spec (1Rx dBm)	Typical (1Rx dBm)
(MCS0) BPSK	1/2	-82	-89
(MCS1) QPSK	1/2	-79	-86
(MCS2) QPSK	3/4	-77	-84
(MCS3) 16-QAM	1/2	-74	-82
(MCS4) 16-QAM	3/4	-70	-79
(MCS5) 64-QAM	2/3	-66	-74
(MCS6) 64-QAM	3/4	-65	-73
(MCS7) 64-QAM	5/6	-64	-66

➤ (HT40)

Modulation	Code Rate	IEEE Spec (1Rx dBm)	Typical (1Rx dBm)
(MCS0) BPSK	1/2	-79	-86
(MCS1) QPSK	1/2	-76	-84
(MCS2) QPSK	3/4	-74	-82
(MCS3) 16-QAM	1/2	-71	-80
(MCS4) 16-QAM	3/4	-67	-80
(MCS5) 64-QAM	2/3	-63	-78
(MCS6) 64-QAM	3/4	-62	-76
(MCS7) 64-QAM	5/6	-61	-73

➤ 802.11ac (HT80)

Modulation	Code Rate	IEEE Spec (1Rx dBm)	Typical (1Rx dBm)
(MCS0) BPSK	1/2	-76	-88
(MCS1) QPSK	1/2	-73	-86
(MCS2) QPSK	3/4	-71	-83
(MCS3) 16-QAM	1/2	-68	-80
(MCS4) 16-QAM	3/4	-64	-78
(MCS5) 64-QAM	2/3	-60	-76
(MCS6) 64-QAM	3/4	-59	-73
(MCS7) 64-QAM	5/6	-58	-71
(MCS8) 256-QAM	3/4	-53	-65
(MCS9) 256-QAM	5/6	-51	-59

Transmit spectrum mask	For transmitted spectral mask for 11b shall be less than -50dB for $22\text{MHz} < f < fc + 22\text{MHz}$. For transmitted spectral mask for 11g shall be less than -40dB for $fc - 30\text{MHz} < f < fc + 30\text{MHz}$. For transmitted spectral mask for 11n 20MHz shall be less than -45dB for $fc - 30\text{MHz} < f < fc + 30\text{MHz}$. For transmitted spectral mask for 11n 40MHz shall be less than -45dB for $fc - 60\text{MHz} < f < fc + 60\text{MHz}$.
Transmit spectrum flatness	For 802.11g the average energy of the constellations in each of spectral lines -16..-1 and +1..+16 will deviate no more than +/- 2dB from their average energy. For 802.11n 40MHz mode, the average energy of the constellations in each of spectral lines -42..-2 and +2..+42 will deviate no more than +/- 2dB from their average energy. The transmitted spectral flatness should be within +/- 4dB.
Transmit center frequency tolerance	The transmitted center frequency tolerance shall be ± 20 ppm maximum.
Carrier suppression	802.11a: The leakage of the center frequency component shall not exceed -15 dB relative to overall transmitted power or, equivalently, +2 dB relative to the average energy of the rest of the sub-carriers. 802.11b: The RF carrier suppression, measured at the channel center frequency, shall be at least 15 dB below the peak $\text{SIN}(x)/x$ power spectrum. 802.11g: The leakage of the center frequency component shall not exceed -15 dB relative to overall transmitted power or, equivalently, +2 dB relative to the average energy of the rest of the sub-carriers. 802.11n: For all 20 MHz modes of transmission The leakage of the center frequency component shall not exceed -15 dB relative to overall transmitted power or, equivalently, +2 dB relative to the average energy of the rest of the sub-carriers. For all 40 MHz modes of transmission The center frequency leakage shall not exceed -18 dB relative to overall transmitted power, or, equivalently, +2 dB relative to the average energy of the rest of the sub-carriers.
Transmit power on ramp and power down ramp time	<ul style="list-style-type: none"> ➤ The transmitting power-on ramp for 10% to 90% of maximum power shall be no greater than 2 μs. ➤ The transmitting power-down ramp for 90% to 10% of maximum power shall be no greater than 2 μs.
Receiver maximum input level	<ul style="list-style-type: none"> ➤ 802.11a Modulation Code Rate IEEE Spec (1Rx dBm) >-30 ➤ 802.11b Modulation Code Rate IEEE Spec (1Rx dBm) DBPSK >-10 DQPSK >-10 CCK >-10 ➤ 802.11g Modulation Code Rate IEEE Spec (1Rx dBm) >-20 ➤ 802.11na Modulation Code Rate IEEE Spec (1Rx dBm) >-30 ➤ 802.11ng Modulation Code Rate IEEE Spec (1Rx dBm) >-20 ➤ 802.11ac Modulation Code Rate IEEE Spec (1Rx dBm) >-30

PCB dimension	➤ 46.0+/-0.1mm x 40.00+/-0.1mm x 1.0+/-0.1mm 4L FR4
Transfer data rate	<ul style="list-style-type: none"> ➤ 802.11a: 6, 9, 12, 18, 24, 36, 48, 54Mbps ➤ 802.11b: 1, 2, 5.5, 11Mbps ➤ 802.11g: 6, 9, 12, 18, 24, 36, 48, 54Mbps ➤ 802.11n: @800GI(400GI) <ul style="list-style-type: none"> ● 20MHz BW <ul style="list-style-type: none"> ▪ 1 Nss: 65(72.2) Mbps maximal ▪ 2 Nss: 130(144.444) Mbps maximal ● 40MHz BW <ul style="list-style-type: none"> ▪ 1 Nss: 135(150) Mbps maximal ▪ 2 Nss: 270(300) Mbps maximal ➤ 802.11ac: @800GI(400GI) <ul style="list-style-type: none"> ● 80MHz BW <ul style="list-style-type: none"> ▪ 1 Nss: 390(433.3) Mbps maximal ▪ 2 Nss: 780(866.7) Mbps maximal
Security	WEP, WPA ,WPA2 ,AES, TKIP
Operation temperature	-10° ~ 60° C
Storage temperature	- 45° ~ 85° C ,R.H:90% (non-condensing)
Antenna	➤ Wi-Fi on-board antenna.

3-4. BT Portion

Item	Key specifications				
Main chipset	➤ MT7668AUN				
Compliance	➤ Bluetooth 5.0				
Frequency range	➤ 2400 ~ 2483.5MHz				
Initial carrier frequency tolerance	➤ +/- 40kHz (typical)				
Modulation technique	➤ Frequency hopping, 1600 hops/sec				
Channel spacing	➤ 1MHz				
Channels support	➤ 79 channels				
Power consumption @25° C	Current consumption	Data Rate	Average.		Units
			Typ.	Max.	
	Sleep mode Radio off	--	1.5	2.0	mA
	BT Tx	BDR	34	38	mA
		EDR	34	38	mA
		BLE	34	38	mA
	BT Rx	BDR	23	26	mA
		EDR	23	26	mA
		BLE	23	26	mA
	Note :				
※The maximum current consumption would be impacted by radiation environment and the driver mechanism.					

Output power (dBm)	➤ + 4 dBm ≤ Output Power ≤ +10dBm (Class I Device)
Sensitivity	➤ -80 dBm (typ.) for pi/4-DQPSK, 0.1%BER
Operation temperature	➤ -10° ~ 60° C
Storage temperature	➤ -45° ~ 85° C , R.H. : 90% (non-condensing)
Antenna	➤ 1 U.FL connector on module for BT external antenna.

4. Mechanical Drawing

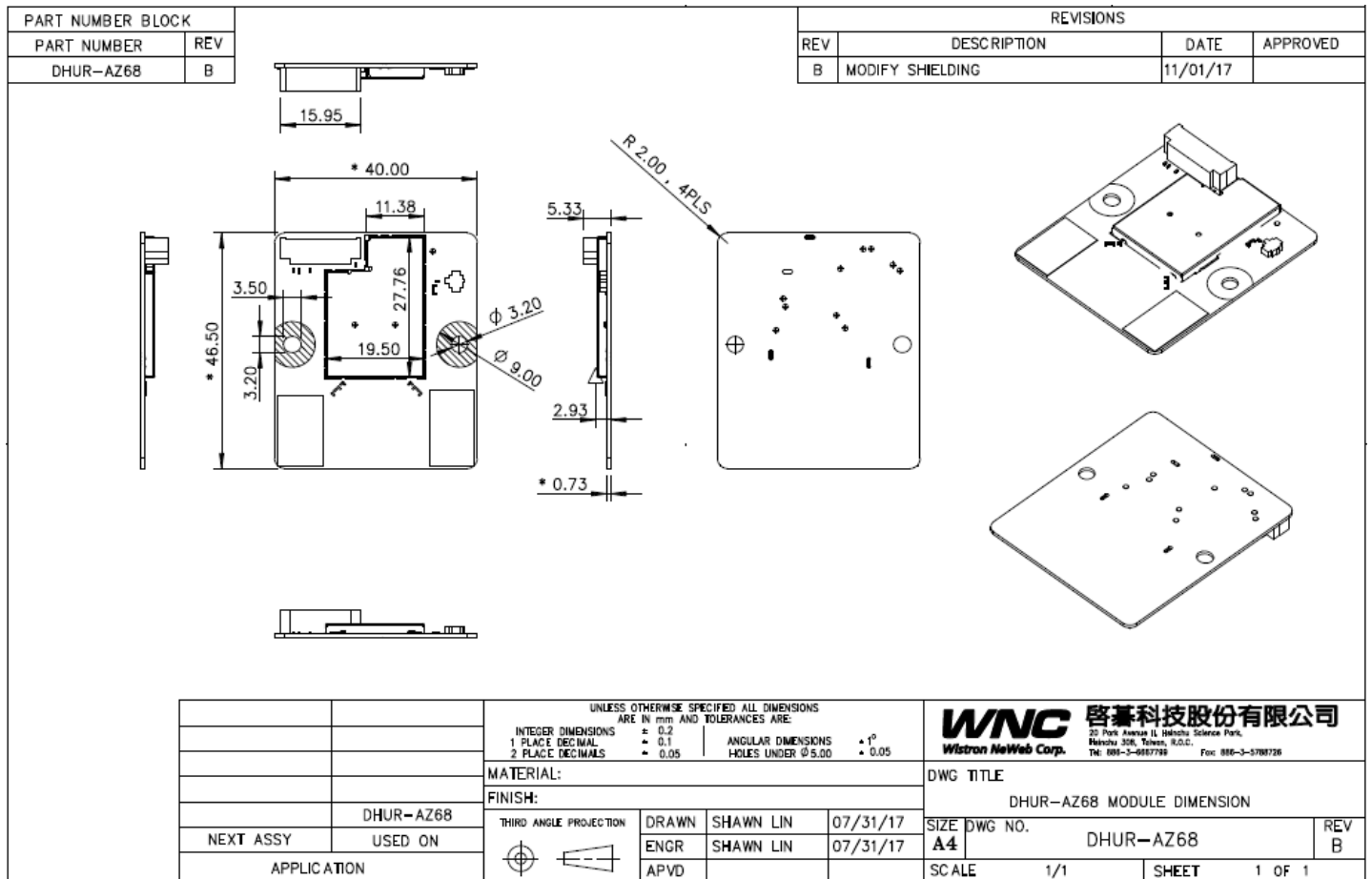

5. Shielding cover Information

PART NUMBER BLOCK		REVISIONS			
PART NUMBER	REV	REV	DESCRIPTION	DATE	APPROVED
3SDAZ6801S1-111ST	A	A	NEW RELEASE	17/10/20	

NOTES:
1. MATERIAL: 洋白銅
2. THICKNESS: 0.2mm

		UNLESS OTHERWISE SPECIFIED ALL DIMENSIONS ARE IN mm AND TOLERANCES ARE:			啓碁科技股份有限公司 <small>20 Park Avenue II, Hsinchu Science Park, Hsinchu 300, Taiwan, R.O.C. TEL: 886-3-6587799 Fax: 886-3-5788726</small>	
		INTEGER DIMENSIONS ± 0.2	ANGULAR DIMENSIONS ± 1°			
		1 PLACE DECIMAL ± 0.1	HOLES UNDER Ø5.00 ± 0.05			
		MATERIAL: SEE NOTES			DWG TITLE	
		FINISH: SEE NOTES			SHIELDING, FRAME, ST, DHUR-AZ68	
THIRD ANGLE PROJECTION	DRAWN	SHAWN LIN	10/20/17	SIZE DWG NO.	REV	
	ENGR	SHAWN LIN	10/20/17	A4	A	
APVD				SCALE	SHEET	
APPLICATION				1/1	1 OF 1	

6. Connector Information

Material :
 Insulation: High temperature plastic UL 94V-0,
 Color Nature(Halogen-Free)
 Contact : Phosphor Bronze
 Fixed Tgb : Phosphor Bronze with Tin Plated

Circuits	Dimension		
	A	B	C
2	1.25(.049)	9.75(.226)	3.85(.152)
3	2.50(.088)	7.00(.276)	5.10(.201)
4	3.75(.148)	8.25(.325)	6.35(.250)
5	5.00(.197)	9.50(.374)	7.60(.299)
6	6.25(.246)	10.75(.423)	8.85(.346)
7	7.50(.295)	12.00(.472)	10.10(.398)
8	8.75(.344)	13.25(.522)	11.35(.447)
9	10.00(.394)	14.50(.571)	12.60(.496)
10	11.25(.443)	15.75(.620)	13.85(.545)
11	12.50(.492)	17.00(.669)	15.10(.594)
12	13.75(.541)	18.25(.719)	16.35(.644)
13	15.00(.591)	19.50(.768)	17.60(.693)
14	16.25(.640)	20.75(.817)	18.85(.742)
15	17.50(.689)	22.00(.866)	20.10(.791)
16	18.75(.737)	23.25(.914)	21.35(.839)
17	20.00(.786)	24.50(.963)	22.60(.888)
18	21.25(.835)	25.75(1.012)	23.85(.937)
19	22.50(.884)	27.00(1.061)	25.10(.986)
20	23.75(.933)	28.25(1.110)	26.35(1.035)

ORDERING CODE:
C140 ** M * H RO -NH
 ① ② ③ ④ ⑤ ⑥ ⑦

① SERIES NO.:
 ② NO. OF CIRCUITS:
 ③ CONTACTS TYPE: M= SMT
 ④ PLATING OPTION:
 1= TIN OVER NICKEL PLATED
 2= GOLD FLASH PLATING OVER
 1.27µm(50µ") NICKEL
 ⑤ TAIL STYLE: H= RIGHT ANGLE
 ⑥ OPTION: RO= TAPE & REEL PACKING
 ⑦ -NH= FOR LEAD FREE IR PROCESSES
 AND HALOGEN-FREE

Recommended P.C. Board layout

Halogen-Free | Lead Free Process | RoHS Compliant

△					DWG	UNIT: mm / inch	TITLE: 125MM (49")	瀚星股份有限公司 CviLux Corporation
△				DRAWN BY: Clark	04/19-17	TOLERANCE	RIGHT ANGLE SMT TYPE HEADER	
△				ENGINEER: Clark	04/19-17	UNLESS OTHERWISE SPECIFIED	INTERNAL:	
△				CHECKED BY: David	04/19-17	X ± 0.30/0.02 X° ± 3°	FINISH:	
SYN	NAME	DATE	REVISIONS	APPROVED BY: David	04/19-17	.XX ± 0.25/0.00 X° ± 0.5°	DRAWING NO. C14001SA	PART NO. C140**M**HRO-NH
						.XXX ± 0.20/0.08 XX° ±	SCALE 5 / 1	SHEET 1 OF 1

7. Coaxial IPEX Connector

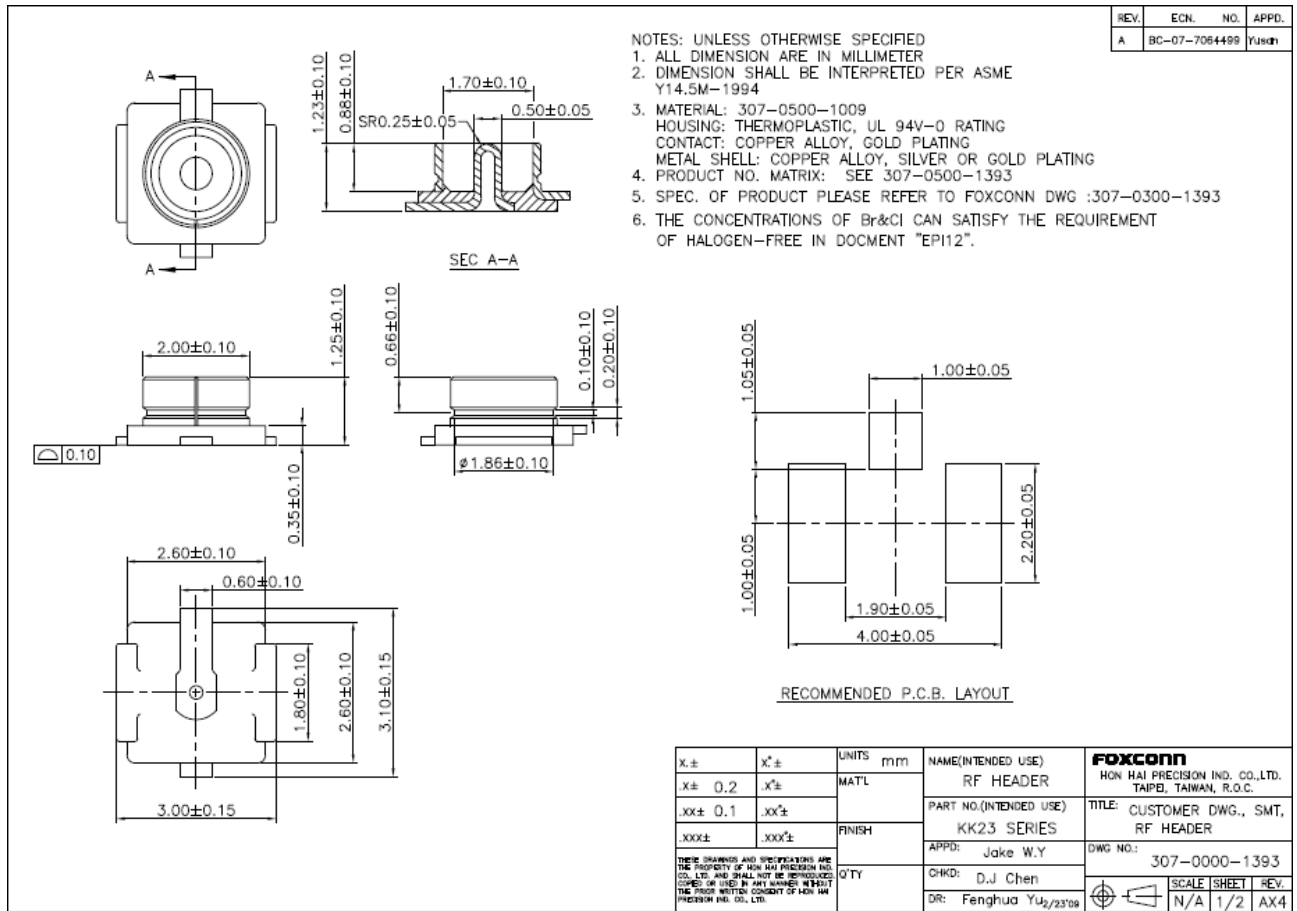

Federal Communication Commission Interference Statement

This equipment has been tested and found to comply with the limits for a Class B digital device, pursuant to Part 15 of the FCC Rules. These limits are designed to provide reasonable protection against harmful interference in a residential installation. This equipment generates, uses and can radiate radio frequency energy and, if not installed and used in accordance with the instructions, may cause harmful interference to radio communications. However, there is no guarantee that interference will not occur in a particular installation. If this equipment does cause harmful interference to radio or television reception, which can be determined by turning the equipment off and on, the user is encouraged to try to correct the interference by one of the following measures:

- Reorient or relocate the receiving antenna.
- Increase the separation between the equipment and receiver.
- Connect the equipment into an outlet on a circuit different from that to which the receiver is connected.
- Consult the dealer or an experienced radio/TV technician for help.

FCC Caution: Any changes or modifications not expressly approved by the party responsible for compliance could void the user's authority to operate this equipment.

This device complies with Part 15 of the FCC Rules. Operation is subject to the following two conditions: (1) This device may not cause harmful interference, and (2) this device must accept any interference received, including interference that may cause undesired operation.

For product available in the USA/Canada market, only channel 1~11 can be operated. Selection of other channels is not possible.

This device is restricted for indoor use.

Professional installation is required

IMPORTANT NOTE:

FCC Radiation Exposure Statement:

This equipment complies with FCC radiation exposure limits set forth for an uncontrolled environment. This equipment should be installed and operated with minimum distance 20cm between the radiator & your body.

IMPORTANT NOTE:

This module is intended for OEM integrator. The OEM integrator is responsible for the compliance to all the rules that apply to the product into which this certified RF module is integrated.

Additional testing and certification may be necessary when multiple modules are used.

USERS MANUAL OF THE END PRODUCT:

In the users manual of the end product, the end user has to be informed to keep at least **20cm** separation with the antenna while this end product is installed and operated. The end user has to be informed that the FCC radio-frequency exposure guidelines for an uncontrolled environment can be satisfied.

The end user has to also be informed that any changes or modifications not expressly approved by the manufacturer could void the user's authority to operate this equipment.

If the labelling area is small than the palm of the hand, then additional FCC part 15.19 statement is required to be available in the users manual: This device complies with Part 15 of FCC rules. Operation is subject to the following two conditions: (1) this device may not cause harmful interference and (2) this device must accept any interference received, including interference that may cause undesired operation.

LABEL OF THE END PRODUCT:

The final end product must be labeled in a visible area with the following " Contains TX FCC ID: NKR-DHURAZ68 ".

If the labelling area is larger than the palm of the hand, then the following FCC part 15.19 statement has to also be available on the label: This device complies with Part 15 of FCC rules. Operation is subject to the following two conditions: (1) this device may not cause harmful interference and (2) this device must accept any interference received, including interference that may cause undesired operation.

Set	Ant.	Port	Brand	Model Name	Antenna Type	Connector	Gain (dBi)		
							WLAN 2.4GHz	WLAN 5GHz	Bluetooth
1	1	1	WNC	-	Printed Antenna	N/A	5.31	5.92	-
	2	2	WNC	-	Printed Antenna	N/A	5.26	5.91	-
2	3	1	WNC	81.EK615.G69	PIFA Antenna	I-PEX	3.71	5.21	-
	4	2	WNC	81.EK615.G68	PIFA Antenna	I-PEX	2.44	6.64	-
3	5	1	WNC	81.EK615.G66	PIFA Antenna	I-PEX	2.02	5.20	-
	6	2	WNC	81.EK615.G65	PIFA Antenna	I-PEX	0.64	5.06	-
4	7	1	WNC	81.EK615.G72	PIFA Antenna	I-PEX	1.08	3.67	-
	8	2	WNC	81.EK615.G71	PIFA Antenna	I-PEX	0.68	2.47	-
5	9	1	WNC	81.EK615.G56	PIFA Antenna	I-PEX	1.97	3.83	-
	10	2	WNC	81.EK615.G57	PIFA Antenna	I-PEX	1.73	3.88	-
6	11	1	WNC	81.EK615.G58	PIFA Antenna	I-PEX	-	-	5.85
7	12	1	WNC	81.EK615.G59	PIFA Antenna	I-PEX	-	-	4.03
8	13	1	WNC	81.EK615.G51	PIFA Antenna	I-PEX	-	-	1.29
9	14	1	WNC	81.EK615.G64	PIFA Antenna	I-PEX	-	-	-0.5
10	15	1	WNC	81.EK615.G67	PIFA Antenna	I-PEX	-	-	1.84
11	16	1	WNC	81.EK615.G70	PIFA Antenna	I-PEX	-	-	0.73

This device complies with Industry Canada's licence-exempt RSSs. Operation is subject to the following two conditions:

- (1) This device may not cause interference; and
- (2) This device must accept any interference, including interference that may cause undesired operation of the device.

Le présent appareil est conforme aux CNR d'Industrie Canada applicables aux appareils radio exempts de licence. L'exploitation est autorisée aux deux conditions suivantes : (1) l'appareil ne doit pas produire de brouillage, et (2) l'utilisateur de l'appareil doit accepter tout brouillage radioélectrique subi, même si le brouillage est susceptible d'en compromettre le fonctionnement.

For product available in the USA/Canada market, only channel 1~11 can be operated. Selection of other channels is not possible.

Pour les produits disponibles aux États-Unis / Canada du marché, seul le canal 1 à 11 peuvent être exploités. Sélection d'autres canaux n'est pas possible.

This radio transmitter (4441A-DHURAZ68) has been approved by Industry Canada to operate with the antenna types listed below with the maximum permissible gain indicated. Antenna types not included in this list, having a gain greater than the maximum gain indicated for that type, are strictly prohibited for use with this device.

Le présent émetteur radio (4441A-DHURAZ68) a été approuvé par Industrie Canada pour fonctionner avec les types d'antenne énumérés ci-dessous et ayant un gain admissible maximal d'antenne. Les types d'antenne non inclus dans cette liste, ou dont le gain est supérieur au gain maximal indiqué, sont strictement interdits pour l'exploitation de l'émetteur.

Set	Ant.	Port	Brand	Model Name	Antenna Type	Connector	Gain (dBi)		
							WLAN 2.4GHz	WLAN 5GHz	Bluetooth
1	1	1	WNC	-	Printed Antenna	N/A	5.31	5.92	-
	2	2	WNC	-	Printed Antenna	N/A	5.26	5.91	-
2	3	1	WNC	81.EK615.G69	PIFA Antenna	I-PEX	3.71	5.21	-
	4	2	WNC	81.EK615.G68	PIFA Antenna	I-PEX	2.44	6.64	-
3	5	1	WNC	81.EK615.G66	PIFA Antenna	I-PEX	2.02	5.20	-
	6	2	WNC	81.EK615.G65	PIFA Antenna	I-PEX	0.64	5.06	-
4	7	1	WNC	81.EK615.G72	PIFA Antenna	I-PEX	1.08	3.67	-
	8	2	WNC	81.EK615.G71	PIFA Antenna	I-PEX	0.68	2.47	-
5	9	1	WNC	81.EK615.G56	PIFA Antenna	I-PEX	1.97	3.83	-
	10	2	WNC	81.EK615.G57	PIFA Antenna	I-PEX	1.73	3.88	-
6	11	1	WNC	81.EK615.G58	PIFA Antenna	I-PEX	-	-	5.85
7	12	1	WNC	81.EK615.G59	PIFA Antenna	I-PEX	-	-	4.03

Set	Ant.	Port	Brand	Model Name	Antenna Type	Connector	Gain (dBi)		
							WLAN 2.4GHz	WLAN 5GHz	Bluetooth
8	13	1	WNC	81.EK615.G51	PIFA Antenna	I-PEX	-	-	1.29
9	14	1	WNC	81.EK615.G64	PIFA Antenna	I-PEX	-	-	-0.5
10	15	1	WNC	81.EK615.G67	PIFA Antenna	I-PEX	-	-	1.84
11	16	1	WNC	81.EK615.G70	PIFA Antenna	I-PEX	-	-	0.73

The device for operation in the band 5150–5250 MHz is only for indoor use to reduce the potential for harmful interference to co-channel mobile satellite systems.

les dispositifs fonctionnant dans la bande 5150-5250 MHz sont réservés uniquement pour une utilisation à l'intérieur afin de réduire les risques de brouillage préjudiciable aux systèmes de satellites mobiles utilisant les mêmes canaux.

The maximum antenna gain permitted for devices in the band 5725-5850 MHz shall be such that the equipment still complies with the e.i.r.p. limits specified for point-to-point and non-point-to-point operation as appropriate.

le gain maximal d'antenne permis (pour les dispositifs utilisant la bande 5725-5850 MHz) doit se conformer à la limite de p.i.r.e. spécifiée pour l'exploitation point à point et non point à point, selon le cas.

IMPORTANT NOTE:

IC Radiation Exposure Statement:

This equipment complies with IC RSS-102 radiation exposure limits set forth for an uncontrolled environment. This equipment should be installed and operated with minimum distance 20cm between the radiator & your body.

Cet équipement est conforme aux limites d'exposition aux rayonnements IC établies pour un

environnement non contrôlé. Cet équipement doit être installé et utilisé avec un minimum de 20 cm

de distance entre la source de rayonnement et votre corps.

IMPORTANT NOTE:

This module is intended for OEM integrator. The OEM integrator is responsible for the compliance to all the rules that apply to the product into which this certified RF module is integrated.

Additional testing and certification may be necessary when multiple modules are used.

Any changes or modifications not expressly approved by the manufacturer could void the user's authority to operate this equipment.

USERS MANUAL OF THE END PRODUCT:

In the users manual of the end product, the end user has to be informed to keep at least 20cm separation with the antenna while this end product is installed and operated. The end user has to be informed that the IC radio-frequency exposure guidelines for an uncontrolled environment can be satisfied.

The end user has to also be informed that any changes or modifications not expressly approved by the manufacturer could void the user's authority to operate this equipment. Operation is subject to the following two conditions: (1) this device may not cause harmful interference and (2) this device must accept any interference received, including interference that may cause undesired operation.

LABEL OF THE END PRODUCT:

The final end product must be labeled in a visible area with the following " Contains IC: 4441A-DHURAZ68 ".

The Host Model Number (HMN) must be indicated at any location on the exterior of the end product or product packaging or product literature which shall be available with the end product or online.