

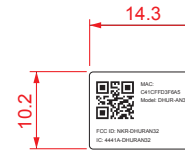

PART NUMBER BLOCK	
PART NUMBER	REV
4L-DHURAN3-001	A

REVISIONS			
REV	DESCRIPTION	DATE	APPROVED
A	RELEASE TO FILE	07/05/17	EDWARD SU

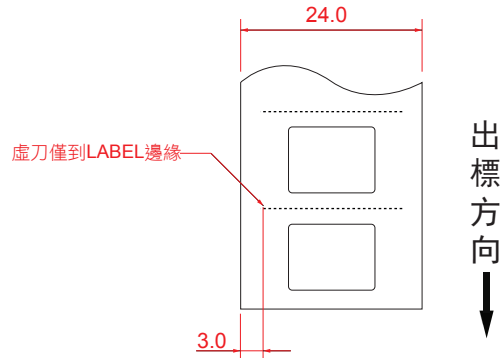

- NOTES:
- MATERIAL: POLYIMIDE FILM, 高溫標籤POLYONICS XF-581, t=0.038mm, 可打印
ADHESIVE: 壓克力背膠, t=0.025mm
 - COLOR:
 - 底色為材質原色
 - 捲狀出貨, 離型紙左右間距各3±0.5mm, 齒刀上下間距各1.5±0.5mm
 - 被貼物: 鐵件
 - TEMPERATURE RESISTANT= 200° C

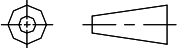
		UNLESS OTHERWISE SPECIFIED ALL DIMENSIONS ARE IN mm AND TOLERANCES ARE:				 啟碁科技股份有限公司 No. 10-1, Li-hsin Road I, Science-based Industrial Park, Hsinchu 300, Taiwan, R.O.C. Tel: 886-3-6667799 Fax: 886-3-6667711	
		INTEGRAL DIMENSIONS ±0.2 1 PLACE DECIMAL ±0.2	ANGULAR DIMENSIONS ±2° HOLES UNDER ψ 5.00 ±0.2		DWG TITLE LABEL, FCC, SHIELDING, DHUR-AN32		
		MATERIAL: SEE NOTES					SIZE A4 DWG NO. 4L-DHURAN3-001 REV A
		FINISH: SEE NOTES				SCALE 1/1 SHEET 1 OF 1	
NEXT ASSY	DHUR-AN32 USED ON	THIRD ANGLE PROJECTION 	DRAWN ENGR APVD	CATHY CHEN CATHY CHEN EDWARD SU	07/05/17 07/05/17 07/05/17		
APPLICATION							