

Straubing, July 11, 2001

TEST - REPORT

No. 50530-10437

for

RCI01-340

Uniform EMC design: RCI01-340W

Receiver

Applicant: ELDAT GmbH

Purpose of testing: To show compliance with

FCC Code of Federal Regulations,
Part 15 Subpart B Class B

Industry Canada Radio Standards
Specification RSS-210 Issue 2,
Section 6.1 (Category I Equipment)

Note:

The test data of this report relate only to the individual item which has been tested. This report shall not be reproduced except in full extent without the written approval of the testing laboratory.

Table of Contents

1.	Administrative Data	3
2.	Identification of Test Laboratory	4
3.	Summary of Test Results	5
4.	Operation Mode of EUT	6
5.	Configuration of EUT and Peripheral Devices	7
6.	Measuring Methods	8
6.1.	Conducted Emission 0.45 MHz - 30 MHz (§15.107) / RSS-210 Section 7.4)	8
6.2.	Radiated Emission 30 MHz - 1 GHz (FCC §15.109 / RSS-210 Section 7.3)	10
6.3.	Radiated Emission 1 GHz - 2 GHz (FCC §15.109 / RSS-210 Sections 7.3)	12
7.	Equipment List	14
8.	Photographs Taken During Testing	16
9.	List of Measurements	20
9.1.	List of Measurements According To FCC Part 15 Subpart B	21
9.2.	List of Measurements According To Industry Canada RSS- 21022	
10.	Referenced Regulations	23
11.	Test Results	24

1. Administrative Data

Equipment Under Test (EUT):	RCI01-340 (390 MHz) Uniform EMC design: RCI01-340W (The applicant declares both models are technical identic. The only difference is the form of the synthetic case.)
Serial number(s):	eng 01
Type of equipment:	Receiver
Parts/accessories:	---
FCC-ID:	---
<hr/>	
Applicant: (full address)	ELDAT GmbH Im Gewerbepark 14 D-15711 Zeesen
Contract identification:	Order no. 204648
Contact person:	Mr. Puppel
Manufacturer:	ELDAT GmbH
<hr/>	
Receipt of EUT:	June 27, 2001
Date of test:	June 28 to July 2, 2001
Note:	---
<hr/>	
Responsible for testing:	Thomas Eberl
Responsible for test report:	Thomas Eberl (cj)

2. Identification of Test Laboratory

Test Laboratory:
(full address): Senton GmbH EMI/EMC Test Center
Aeussere Fruehlingstrasse 45
D-94315 Straubing
Germany

Contact person: Mr. Johann Roidt
Communication: Telephone (+49) 0 94 21 / 55 22-0
Fax (+49) 0 94 21 / 55 22-99
eMail: Office@senton.de

FCC registration number: 90926
Industry Canada file number: IC 3050

3. Summary of Test Results

The tested sample complies with the limits forth in the Code of Regulations

FCC Part 15 Subpart B Class B
of the Federal Communication Commission (FCC).

and the

**Radio Standards Specification RSS-210 Issue 2, Section 6.1 for Low Power
Licence-Exempt Radiocommunication Devices of Industry Canada.**



Johann Roidt
Technical Manager



Thomas Eberl
Test Engineer

4. Operation Mode of EUT

- RX mode
- with supply voltage 24 V AC

5. Configuration of EUT and Peripheral Devices

Configuration of EUT

EUT is configured as stand-alone device in horizontal position

Configuration of cables of EUT

- non-shielded AC-supply line (fixed)
- non-shielded wires connected to I/O ports

Configuration of peripheral devices connected to EUT

6. Measuring Methods

6.1. Conducted Emission 0.45 MHz - 30 MHz (§15.107) / RSS-210 Section 7.4)

Conducted emissions were measured in the frequency range 0.45 MHz to 30 MHz. The bandwidth of the EMI-Receiver was set to 9 kHz and the detector-function was set to CISPR quasi-peak.

The test setup was made in accordance with ANSI C63.4-1992.

Measurements were performed on phase and neutral lines of the power-cords of the tested system. Preliminary scans were taken with the detector-function of the EMI-receiver set to peak to determine the conducted EMI-profile of the EUT. At the final test the cables and equipment were placed and moved within the range of positions likely to find their maximum emissions.

See figure 1 for the measurement setup.

Test equipment used (see equipment list for details):

04, 22, 23, 60, 63

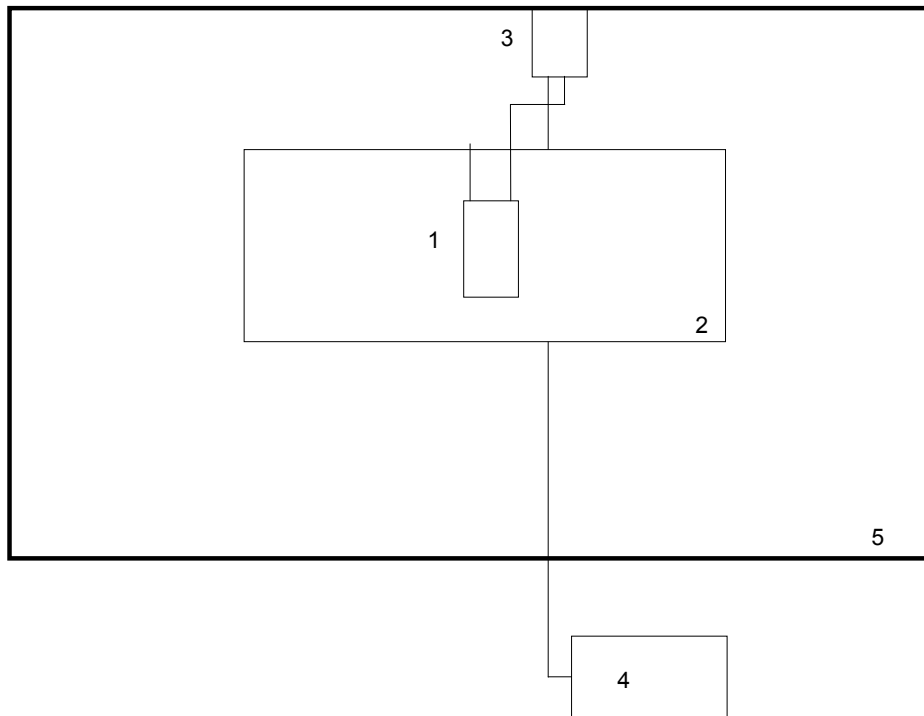

Figure 1: Measurement setup for conducted emission test

- | | |
|-------------------------|------------------------|
| 1 Receiver (EUT) | 3 LISN for EUT |
| 2 Wooden table | 4 Test receiver |
| | 5 Shielded room |

6.2. Radiated Emission 30 MHz - 1 GHz (FCC §15.109 / RSS-210 Section 7.3)

Radiated emissions are measured over the frequency range from 30 MHz to 1 GHz. The bandwidth of the EMI-receiver is set to 120 kHz and the detector-function is set to CISPR quasi-peak.

The test setup is made in accordance with ANSI C63.4-1992.

Measurements are made in both the horizontal and vertical planes of polarization. Preliminary scans are taken in a semi-anechoic room using a spectrum analyzer with the detector function set to peak. Hand-held or body-worn devices are rotated through three orthogonal axes to determine which attitude and configuration produces the highest emission relative to the limit and therefore shall be used for final testing.

All tests are performed at a test-distance of 3 meters.

For final testing an open-area test-site is used. During the tests the EUT is rotated all around and the receiving-antenna is raised and lowered from 1 meter to 4 meters to find the maximum levels of emissions. The cables and equipment is placed and moved within the range of position likely to find their maximum emissions.

See figure 2 for the measurement setup.

Test equipment used (see equipment list for details):

01, 02, 05, 12, 38, 39, 40, 41, 58, 61, 64, 66

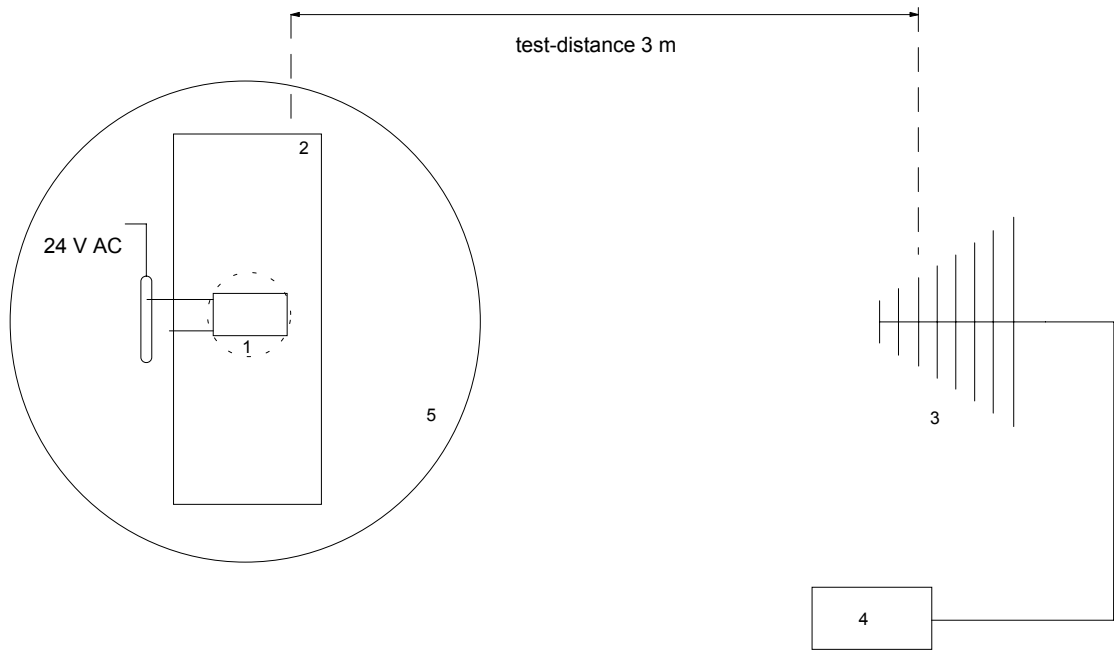

Figure 2: Measurement setup for radiated emission test below 1 GHz

- | | |
|---|--|
| <p>1 Receiver (EUT)
 2 Wooden table</p> | <p>3 Measurement antenna
 4 Test receiver
 5 Turn table</p> |
|---|--|

6.3. Radiated Emission 1 GHz - 2 GHz (FCC §15.109 / RSS-210 Sections 7.3)

Radiated emissions are measured in the frequency range 1 GHz to 2 GHz. Resolution and video bandwidth of the spectrum analyzer are set to 1 MHz.

Hand-held or body-worn devices are rotated through three orthogonal axes to determine which attitude and configuration produces the highest emission relative to the limit and therefore shall be used for final testing.

Additional measurements are performed at critical frequencies with reduced span. EUT is rotated all around and receiving antenna is raised and lowered to find the maximum levels of emission. The cables and equipment are placed and moved within the range of position likely to find their maximum emissions.

All tests are performed in a semi-anechoic chamber with a test-distance of 3 meters.

If possible preamplifiers are used for the whole frequency range. Special care is taken to avoid overload in transmit mode (using appropriate attenuators or filters if necessary).

See figure 3 for the measurement setup.

Test equipment used (see equipment list for details):

02, 13, 14, 16, ,42, 44, 45, 57, 64

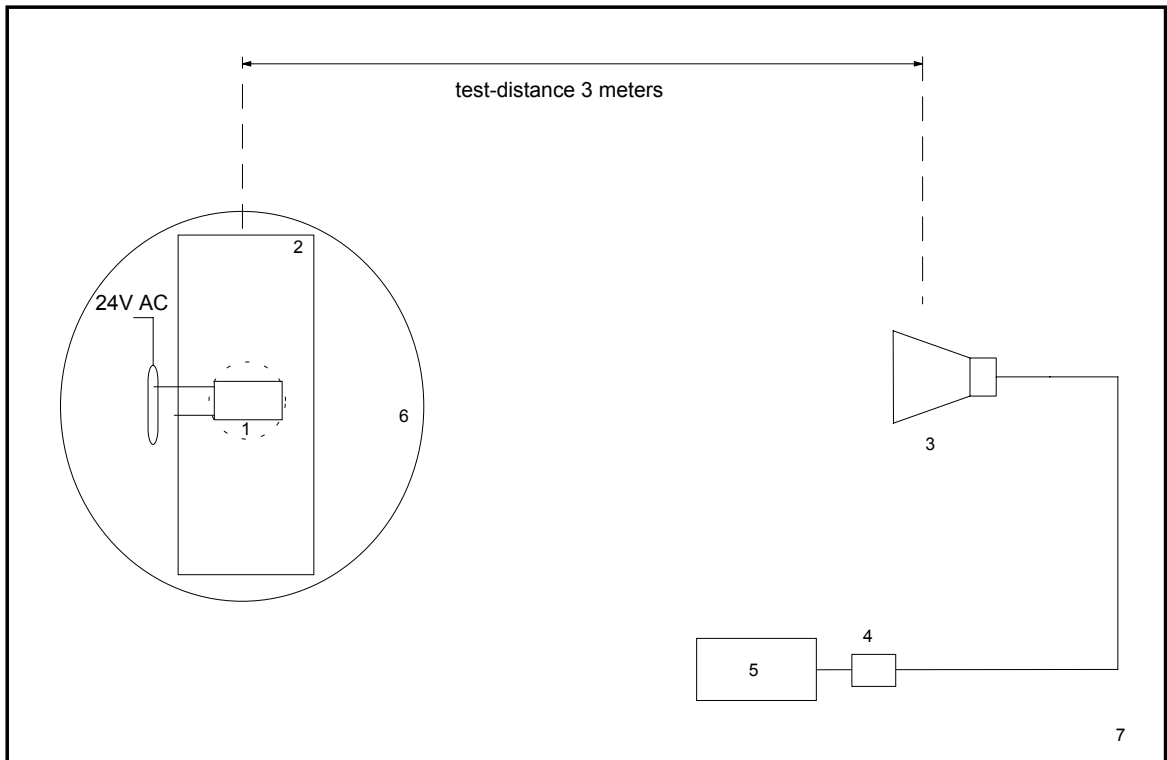

Figure 3: Measurement setup for radiated emission test above 1 GHz

- | | | | |
|---|----------------|---|------------------------------|
| 1 | Receiver (EUT) | 3 | Measurement antenna |
| 2 | Wooden table | 4 | Preamplifier (if applicable) |
| | | 5 | Spectrum analyzer |
| | | 6 | Turn table |
| | | 7 | Semi anechoic room |

7. Equipment List

To facilitate reference to test equipment used for related tests, each item of test equipment and ancillaries such as cables are identified (numbered) by the Test Laboratory.

No.	Type	Model	Serial Number	Manufacturer
01	Spectrum Analyzer	R 3271	05050023	Advantest
02	EMI Test Receiver	ESMI	839379/013 839587/006	Rohde & Schwarz
03	Test Receiver	ESH 3	880112/032	Rohde & Schwarz
04	Test Receiver	ESHS 10	860043/016	Rohde & Schwarz
05	Test Receiver	ESV	881414/009	Rohde & Schwarz
06	Test Receiver	ESVP	881120/024	Rohde & Schwarz
07	Audio Analyzer	UPA	862954	Rohde & Schwarz
08	Power Meter	NRVS	836856/015	Rohde & Schwarz
09	Power Sensor	NRV-Z52	837901/030	Rohde & Schwarz
10	Power Sensor	NRV-Z4	863828/015	Rohde & Schwarz
11	Preamplifier	ESV-Z3	860907/004	Rohde & Schwarz
12	Preamplifier	R14601		Advantest
13	Preamplifier	ACX/080-3030	32640	CTT
14	Preamplifier	ACO/180-3530	32641	CTT
15	Signal Generator	SMS	872166/039	Rohde & Schwarz
16	Signal Generator	HP 8673 D	2930A00966	Hewlett Packard
17	Waveform Generator	HP 33120 A	US34005375	Hewlett Packard
18	Attenuator 20 dB	4776-20	9503	Narda
19	Attenuator 10 dB	4776-10	9412	Narda
20	Pulse Limiter	ESH 3-Z2	1144	Rohde & Schwarz
21	Pulse Limiter	11947 A	3107A00566	Hewlett Packard
22	V-Network	ESH 3-Z5	862770/018	Rohde & Schwarz
23	V-Network	ESH 3-Z5	894785/005	Rohde & Schwarz
24	V-Network	ESH 3-Z5	830952/025	Rohde & Schwarz
25	V-Network	ESH 3-Z6	830722/010	Rohde & Schwarz
26	V-Network	NSLK 8127	8127152	Schwarzbeck
27	V-Network	NNLA 8119	8119148	Schwarzbeck
28	V-Network	SE 01	01	Senton
29	T-Network	ESH 3-Z4	890602/011	Rohde & Schwarz
30	T-Network	ESH 3-Z4	890602/012	Rohde & Schwarz
31	High Impedance Probe	TK 9416	01	Schwarzbeck
32	High Impedance Probe	TK 9416	02	Schwarzbeck
33	Current Probe	ESH 2-Z1	863366/18	Rohde & Schwarz
34	Current Probe	ESV-Z1	862553/3	Rohde & Schwarz

No.	Type	Model	Serial Number	Manufacturer
35	Absorbing Clamp	MDS 21	80911	Lüthi
36	Absorbing Clamp	MDS 21	79690	Lüthi
37	Loop Antenna	HFH2-Z2	882964/1	Rohde & Schwarz
38	Biconical Antenna	HK 116	842204/001	Rohde & Schwarz
39	Biconical Antenna	HK 116	836239/02	Rohde & Schwarz
40	Log. Periodic Antenna	HL 223	841516/023	Rohde & Schwarz
41	Log. Periodic Antenna	HL 223	834408/12	Rohde & Schwarz
42	Horn Antenna	3115	9508-4553	Emco
43	Horn Antenna	3160-03	9112-1003	Emco
44	Horn Antenna	3160-04	9112-1001	Emco
45	Horn Antenna	3160-05	9112-1001	Emco
46	Horn Antenna	3160-06	9112-1001	Emco
47	Horn Antenna	3160-07	9112-1008	Emco
48	Horn Antenna	3160-08	9112-1002	Emco
49	Horn Antenna	3160-09	9403-1025	Emco
50	Digital multimeter	199	463386	Keithley
51	DC Power Supply	NGSM 32/10	203	Rohde & Schwarz
52	DC Power Supply	NGB	2455	Rohde & Schwarz
53	DC Power Supply	NGA	386	Rohde & Schwarz
54	Temperature Test Chamber	HT4010	07065550	Heraeus
55	Cable	RG214	1309	Senton
56	Cable	200CM_001	1357	Rosenberger
57	Cable	150CM_001	1479	Rosenberger
58	Cable Set EG1	RG214	1189 - 1191	Senton
59	Cable Set Cabine 1	RG214		Senton
60	Cable Set Cabine 2	RG214		Senton
61	Cable Set Cabine 3	RG214		Senton
62	Shielded Room	No. 1	1451	Senton
63	Shielded Room	No. 2	1452	Senton
64	Semi-anechoic Chamber	No. 3	1453	Siemens
65	Shielded Room	No. 4	1454	Euroshield
66	Open Area Test Site	EG 1		Senton
67	Test fixture			Senton

8. Photographs Taken During Testing

Photos No. 8.1
Test setup for conducted emission test 450 kHz - 30 MHz



Photos No. 8.2 - 8.3

**Test setup for radiated emission pre-test 30 MHz - 1 GHz
and final test 1 GHz - 2 GHz
(semi anechoic room)**



Photos No. 8.4

Test setup for radiated emission final test 30 MHz - 1 GHz (open area test site)

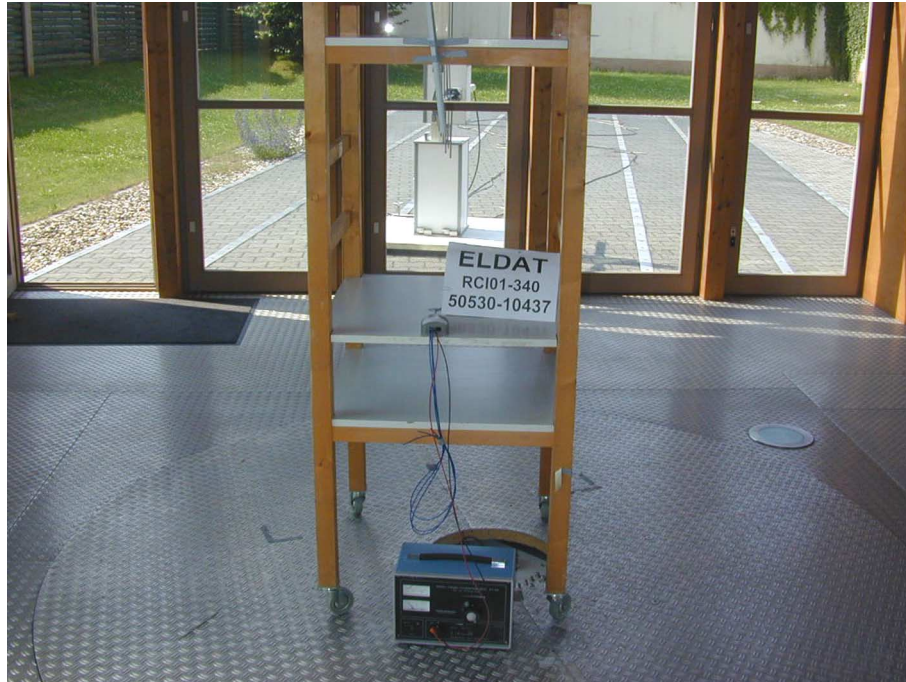

9. List of Measurements

9.1. List of Measurements According To FCC Part 15 Subpart B

FCC Part 15 Subpart B			
Section(s):	Test	Page(s)	Result
§15.107	Conducted emission test 450 kHz - 30 MHz	25 - 28	Passed
§15.109	Radiated emission test 9 kHz - 30 MHz	---	Not Applicable (acc. to §15.33)
§15.109	Radiated emission test 30 MHz - 1 GHz	29 - 36	Passed
§15.109	Radiated emission test 1 GHz - 2 GHz	37 - 40	Passed

9.2. List of Measurements According To Industry Canada RSS-210

Industry Canada RSS-210 Issue 2			
Section(s):	Test	Page(s)	Result
7.4	Conducted emission test 450 kHz - 30 MHz	25 - 28	Passed
7.3	Radiated emission test 30 MHz - 1 GHz	29 - 36	Passed
7.3	Radiated emission test 1 GHz - 2 GHz	37 - 40	Passed

10. Referenced Regulations

All tests were performed with reference to the following regulations and standards:

- | | | | |
|-------------------------------------|-----------------------|--|-------------------|
| <input checked="" type="checkbox"/> | FCC Part 15 Subpart A | Code of Regulations Part 15 (Radio Frequency Devices), Subpart A (General) of the Federal Communication Commission (FCC) | October 20, 1997 |
| <input checked="" type="checkbox"/> | FCC Part 15 Subpart B | Code of Regulations Part 15 (Radio Frequency Devices), Subpart B (Unintentional Radiators) of the Federal Communication Commission (FCC) | October 20, 1997 |
| <input type="checkbox"/> | FCC Part 15 Subpart C | Code of Regulations Part 15 (Radio Frequency Devices), Subpart C (Intentional Radiators) of the Federal Communication Commission (FCC) | October 20, 1997 |
| <input checked="" type="checkbox"/> | ANSI C63.4 | American National Standard for Methods of Measurement of Radio-Noise Emissions from Low-Voltage Electrical and Electronic Equipment in the Range of 9 kHz - 40 GHz | October, 1992 |
| <input checked="" type="checkbox"/> | RSS-210 | Radio Standards Specification RSS-210 Issue 2 for Low Power Licence-Exempt Radiocommunication Devices of Industry Canada | February 24, 1996 |

11. Test Results

Conducted Emission Test 450 kHz - 30 MHz according to FCC Part 15 Subpart B Class B

Model:
RCI01-340

Serial no.:
01

Applicant:
Eldat GmbH

Test site:
Shielded room, cabin no. 2

Tested on:
Linecord EUT
Phase L1

Date of test:
06/28/2001

Operator:
T. Eberl

Test performed:
automatically

File name:

Mode:
RX mode

Supply voltage: 24 V AC

Detector:
Peak / Final Results: QP

Final results:
20 dB Margin

25 Subranges

dB μ V

Limit1: FCC Class B

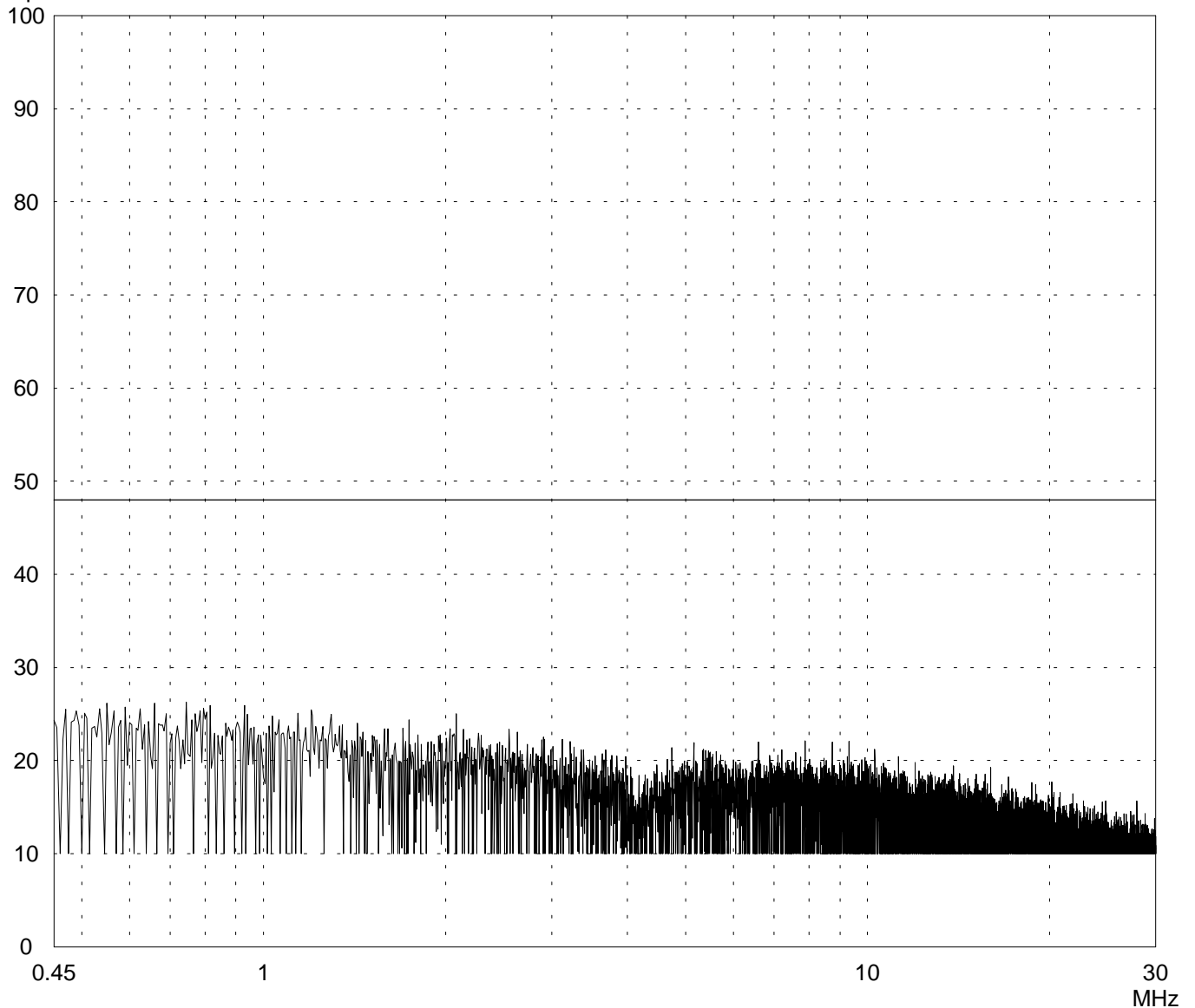

Result:
Limit kept

Project file:
50530-10437

Page 25 of 40 Pages

Conducted Emission Test 450 kHz - 30 MHz according to FCC Part 15 Subpart B Class B

Model: RCI01-340	
Serial no.: 01	
Applicant: Eldat GmbH	
Test site: Shielded room, cabin no. 2	
Tested on: Linecord EUT Phase L1	
Date of test: 06/28/2001	Operator: T. Eberl
Test performed: automatically	File name:

Mode: RX mode
Supply voltage: 24 V AC

Detector: Peak / Final Results: QP

Final results: 20 dB Margin	25 Subranges
--------------------------------	--------------

<i>Frequency MHz</i>	<i>Reading dBμV</i>	<i>Correction factor dB</i>	<i>Value dBμV</i>	<i>Limit dBμV</i>	<i>Limit exceeded</i>
no results					

Result: Limit kept

Project file: 50530-10437	Page 26 of 40 Pages
------------------------------	---------------------

Conducted Emission Test 450 kHz - 30 MHz according to FCC Part 15 Subpart B Class B

Model:
RCI01-340

Serial no.:
01

Applicant:
Eldat GmbH

Test site:
Shielded room, cabin no. 2

Tested on:
Linecord EUT
Phase N

Date of test:
06/28/2001

Operator:
T. Eberl

Test performed:
automatically

File name:

Mode:
RX mode

Supply voltage: 24 V AC

Detector:
Peak / Final Results: QP

Final results:
20 dB Margin

25 Subranges

dB μ V

Limit1: FCC Class B

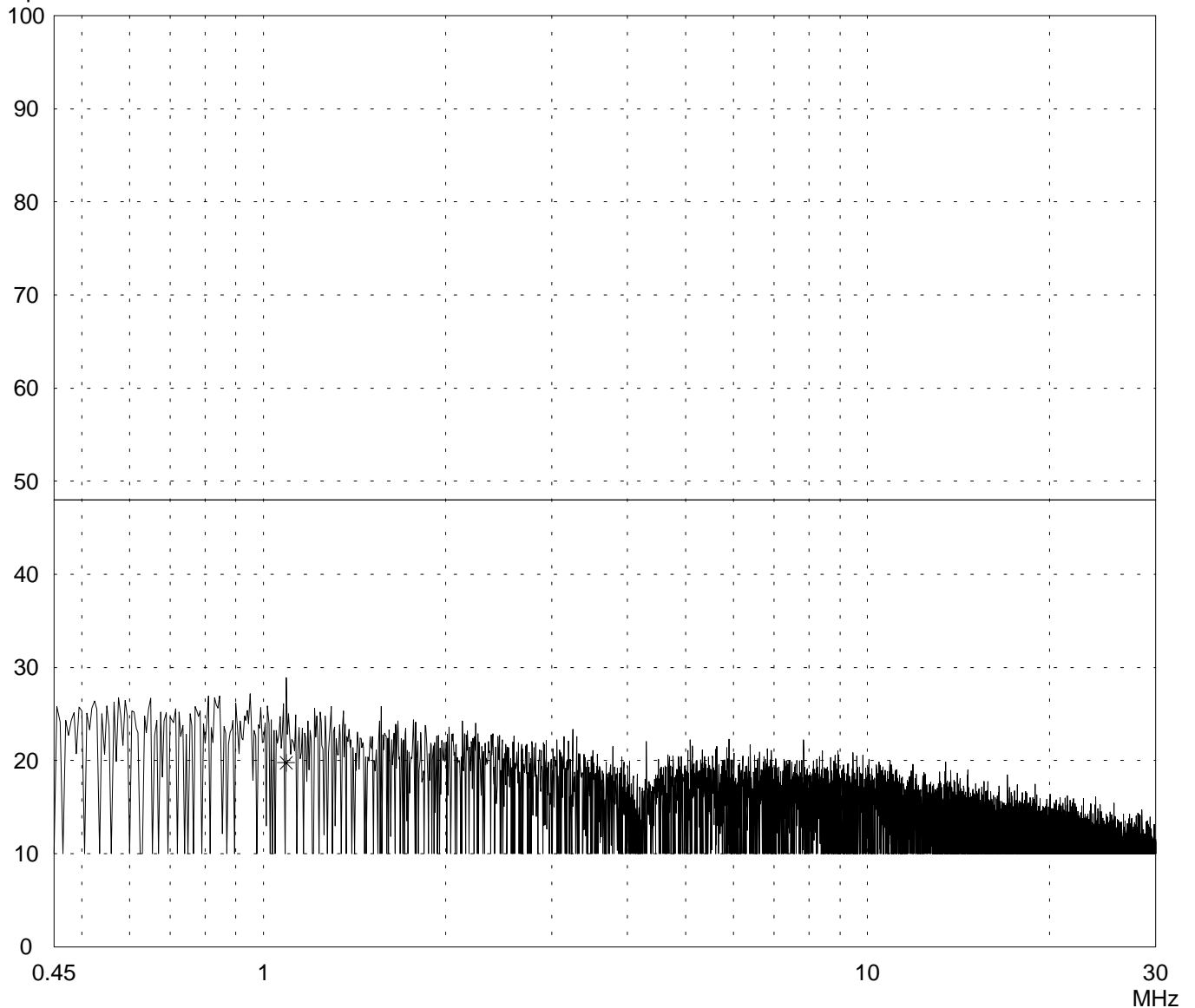

Result:
Limit kept

Project file:
50530-10437

Page 27 of 40 Pages

**Conducted Emission Test 450 kHz - 30 MHz
according to FCC Part 15 Subpart B Class B**

Model:
RCI01-340

Serial no.:
01

Applicant:
Eldat GmbH

Test site:
Shielded room, cabin no. 2

Tested on:
Linecord EUT
Phase N

Date of test: 06/28/2001 Operator: T. Eberl

Test performed: automatically File name:

Mode:
RX mode

Supply voltage: 24 V AC

Detector:
Peak / Final Results: QP

Final results:
20 dB Margin 25 Subranges

<i>Frequency MHz</i>	<i>Reading dBμV</i>	<i>Correction factor dB</i>	<i>Value dBμV</i>	<i>Limit dBμV</i>	<i>Limit exceeded</i>
1.09	19.8		19.8	48.0	

Result:
Limit kept

Project file:
50530-10437

Page 28 of 40 Pages

Radiated Emission Test 30 MHz - 300 MHz according to FCC Part 15 Subpart B Class B

Model: RCI01-340 (390 MHz)	
Serial no.: --	
Applicant: Eldat GmbH	
Test site: Semi anechoic room, cabin no. 3	
Tested on: Test distance 3 metres Horizontal Polarization	
Date of test: 06/29/2001	Operator: T. Eberl
Test performed: automatically	File name:

Mode: - RX mode -EUT AC powered 24 V
--

Detector: Peak

List of values: 10 dB Margin	50 Subranges
---------------------------------	--------------

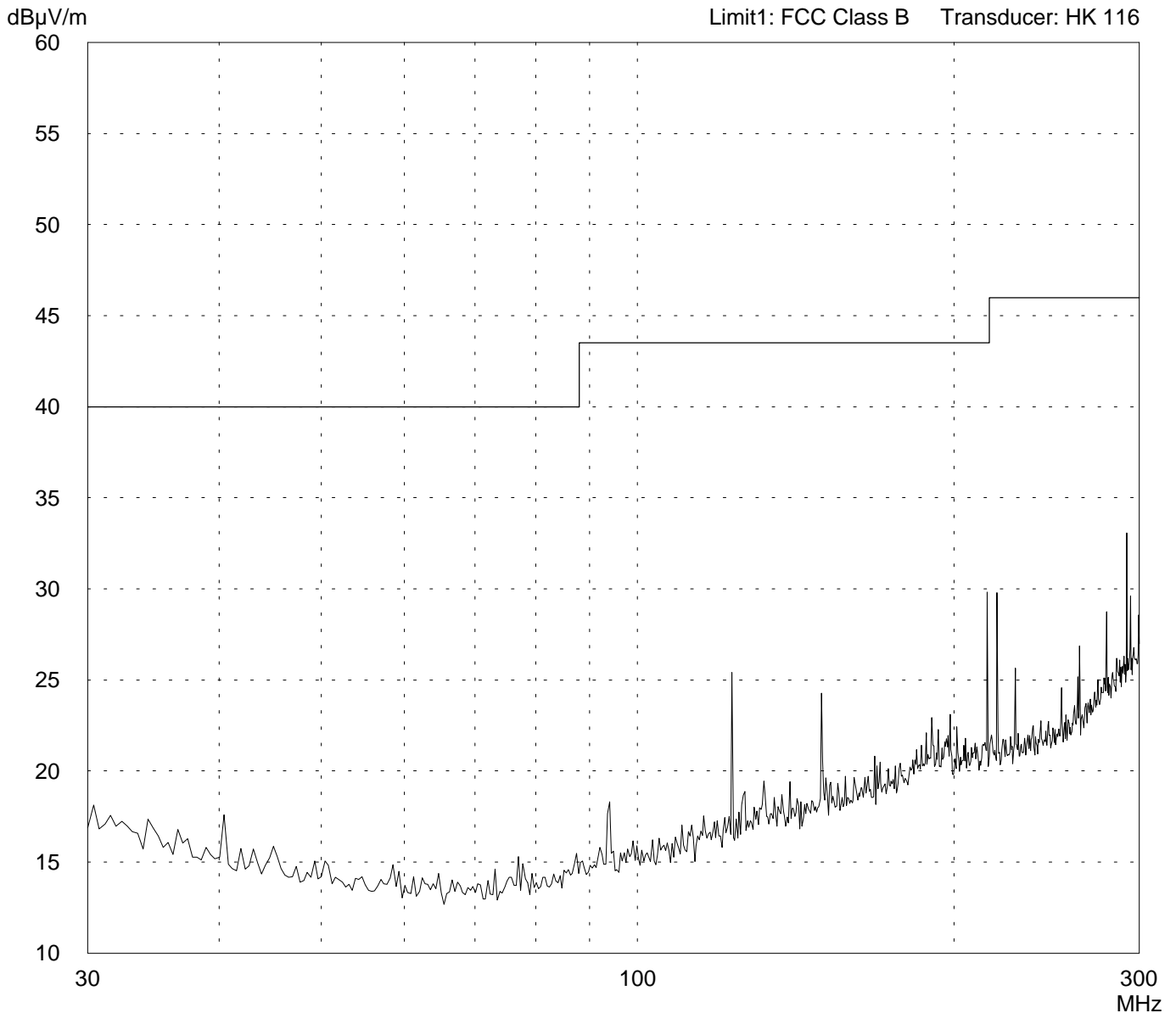

Result: Prescan

Project file: 50530-10437	Page 29 of 40 Pages
------------------------------	---------------------

Radiated Emission Test 30 MHz - 300 MHz according to FCC Part 15 Subpart B Class B

Model:
RCI01-340 (390 MHz)

Serial no.:
--

Applicant:
Eldat GmbH

Test site:
Semi anechoic room, cabin no. 3

Tested on:
Test distance 3 metres
Vertical Polarization

Date of test: 06/29/2001 Operator: T. Eberl

Test performed: automatically File name:

Mode:
- RX mode

-EUT AC powered 24 V

Detector:
Peak

List of values:
10 dB Margin 50 Subranges

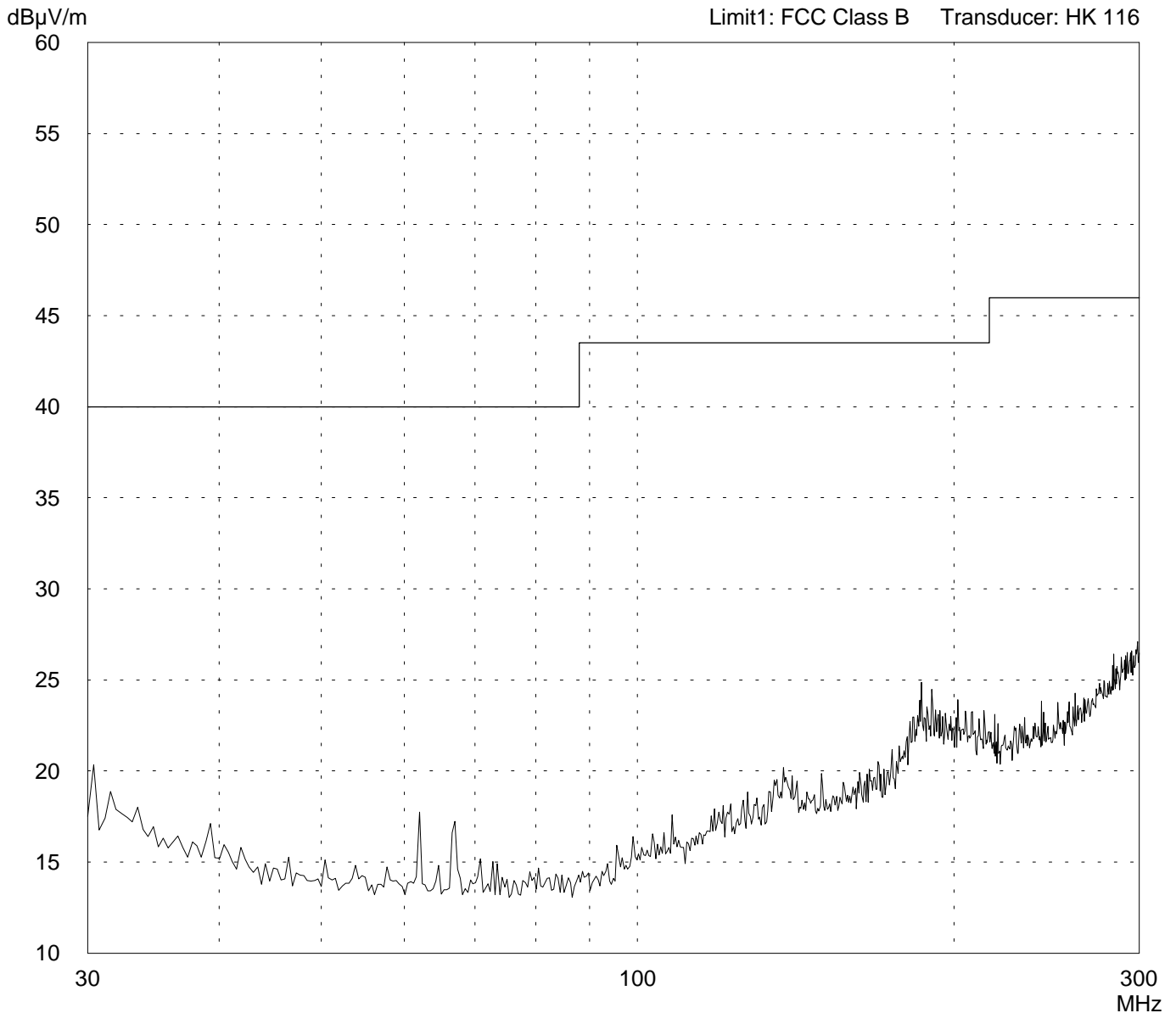

Result:
Prescan

Project file:
50530-10437

Page 30 of 40 Pages

Radiated Emission Test 295 MHz - 1 GHz according to FCC Part 15 Subpart B Class B

Model:
RCI01-340 (390 MHz)

Serial no.:
--

Applicant:
Eldat GmbH

Test site:
Semi anechoic room, cabin no. 3

Tested on:
Test distance 3 metres
Horizontal Polarization

Date of test: 06/29/2001 Operator: T. Eberl

Test performed: automatically File name:

Mode:
- RX mode

-EUT AC powered 24 V

Detector:
Peak

List of values:
10 dB Margin 50 Subranges

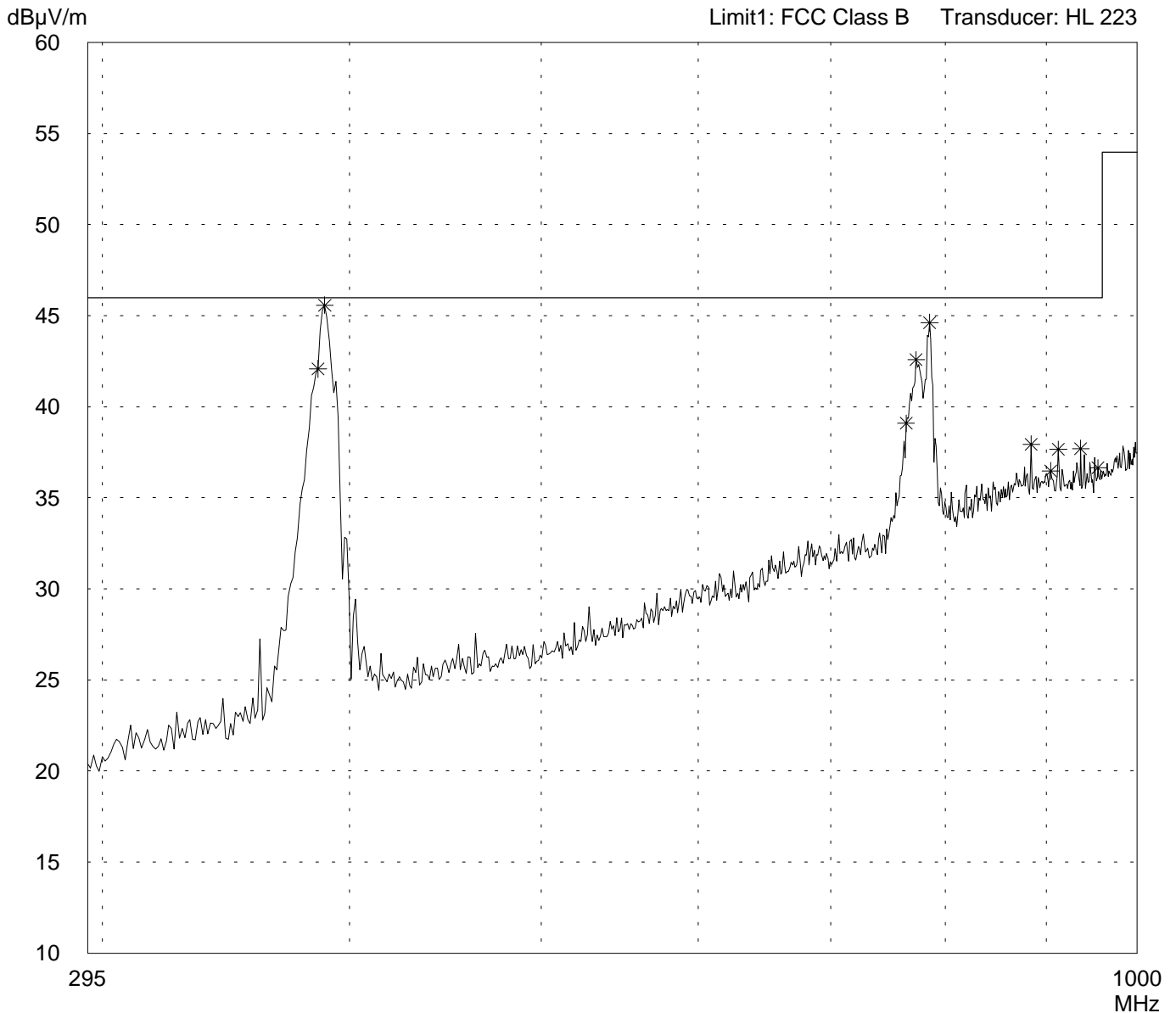

Result:
Prescan

Project file:
50530-10437

Page 31 of 40 Pages

Radiated Emission Test 295 MHz - 1 GHz according to FCC Part 15 Subpart B Class B

Model: RCI01-340 (390 MHz)	
Serial no.: --	
Applicant: Eldat GmbH	
Test site: Semi anechoic room, cabin no. 3	
Tested on: Test distance 3 metres Vertical Polarization	
Date of test: 06/29/2001	Operator: T. Eberl
Test performed: automatically	File name:

Mode: - RX mode	
-EUT AC powered 24 V	

Detector: Peak

List of values: 10 dB Margin	50 Subranges
---------------------------------	--------------

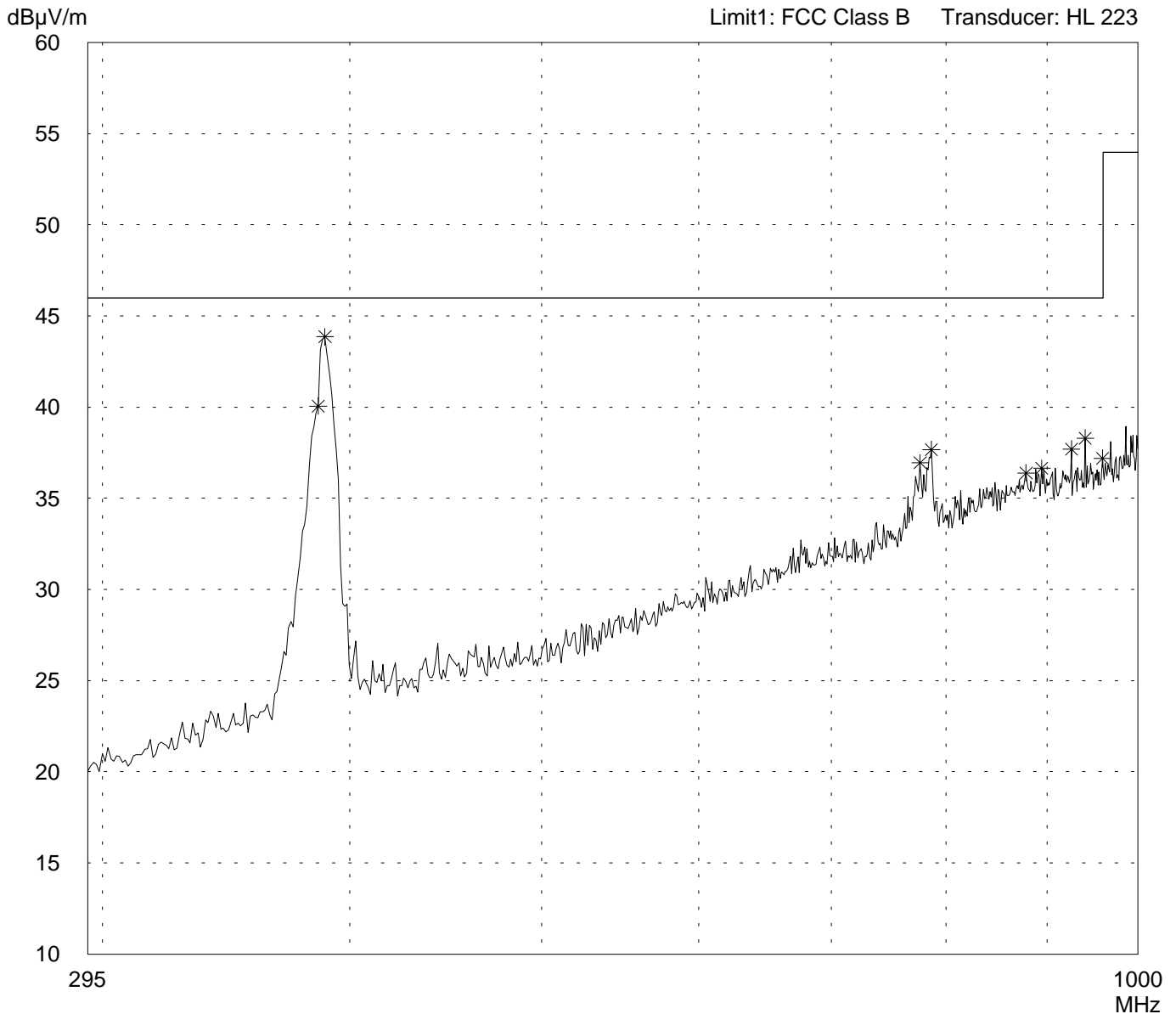

Result: Prescan

Project file: 50530-10437	Page 32 of 40 Pages
------------------------------	---------------------

Radiated Emission Test 30 MHz - 1 GHz according to FCC Part 15 Subpart B Class B

Model: RCI01-340 (390 MHz)	
Serial no.: --	
Applicant: Eldat GmbH	
Test site: Open area test-site I	
Tested on: Test distance 3 metres Horizontal Polarization	
Date of test: 06/29/2001	Operator: T. Eberl
Test performed: by hand	File name:

Mode: - RX mode -EUT AC powered 24 V
--

Detector: Quasi-Peak

List of values: Selected by hand

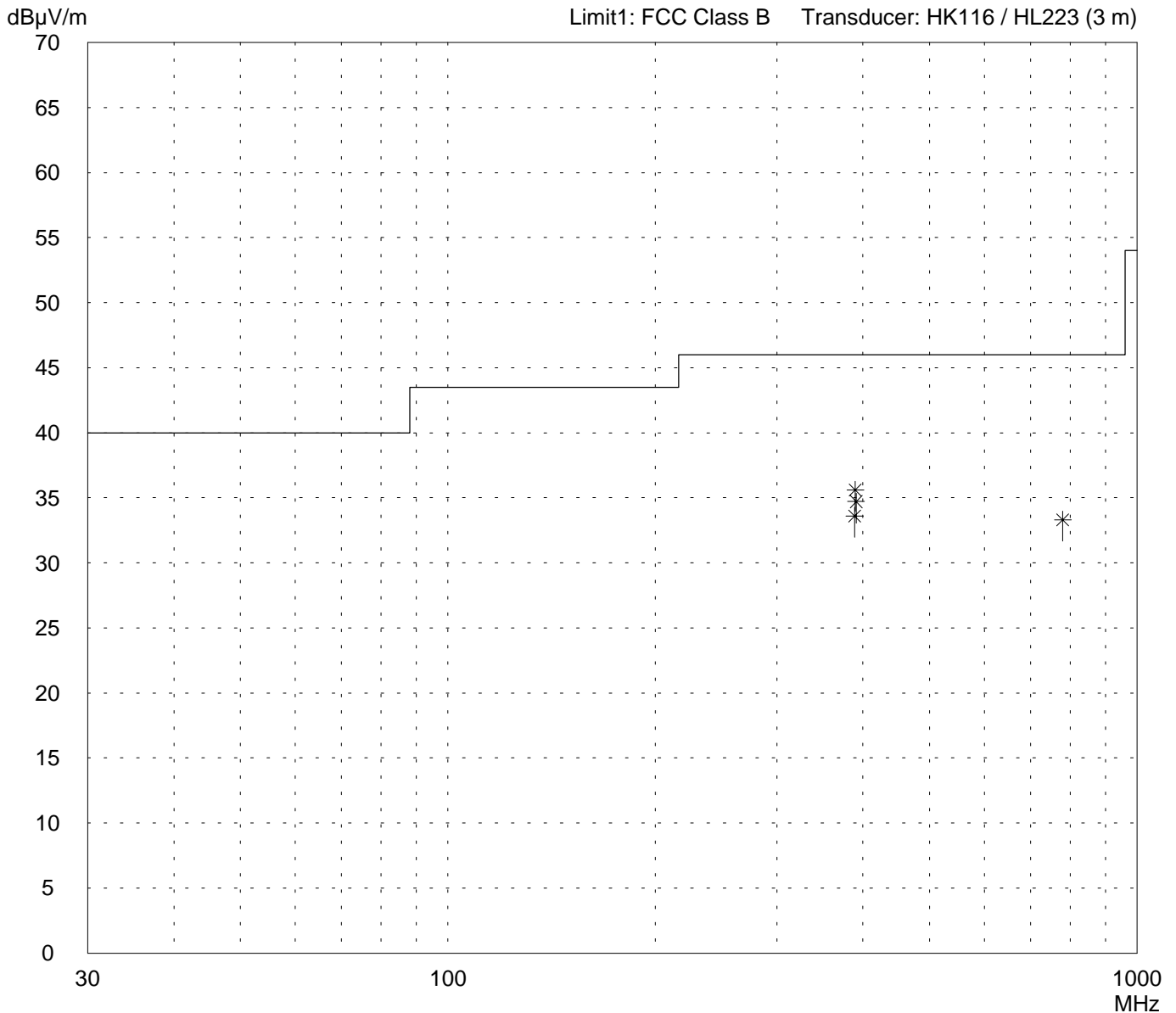

Result: Limit kept

Project file: 50530-10437	Page 33 of 40 Pages
------------------------------	---------------------

**Radiated Emission Test 30 MHz - 1 GHz
according to FCC Part 15 Subpart B Class B**

<p>Model: RCI01-340 (390 MHz)</p> <p>Serial no.: --</p> <p>Applicant: Eldat GmbH</p> <p>Test site: Open area test-site I</p> <p>Tested on: Test distance 3 metres Horizontal Polarization</p> <p>Date of test: Operator: 06/29/2001 T. Eberl</p> <p>Test performed: File name: by hand</p>	<p>Mode: - RX mode</p> <p>-EUT AC powered 24 V</p>
--	--

<p>Detector: Quasi-Peak</p>	<p>List of values: Selected by hand</p>
---------------------------------	---

<i>Frequency MHz</i>	<i>Reading dBμV</i>	<i>Correction factor dB</i>	<i>Value dBμV/m</i>	<i>Limit dBμV/m</i>	<i>Limit exceeded</i>
389.0	11.5	22.1	33.6	46.0	
390.0	13.5	22.1	35.6	46.0	
391.0	12.6	22.1	34.7	46.0	
780.0	1.5	31.8	33.3	46.0	

<p>Result: Limit kept</p>	<p>Project file: 50530-10437</p> <p style="text-align: right;">Page 34 of 40 Pages</p>
-------------------------------	--

Radiated Emission Test 30 MHz - 1 GHz according to FCC Part 15 Subpart B Class B

Model: RCI01-340 (390 MHz)	
Serial no.: --	
Applicant: Eldat GmbH	
Test site: Open area test-site I	
Tested on: Test distance 3 metres Vertical Polarization	
Date of test: 06/29/2001	Operator: T. Eberl
Test performed: by hand	File name:

Mode: - RX mode -EUT AC powered 24 V
--

Detector: Quasi-Peak

List of values: Selected by hand

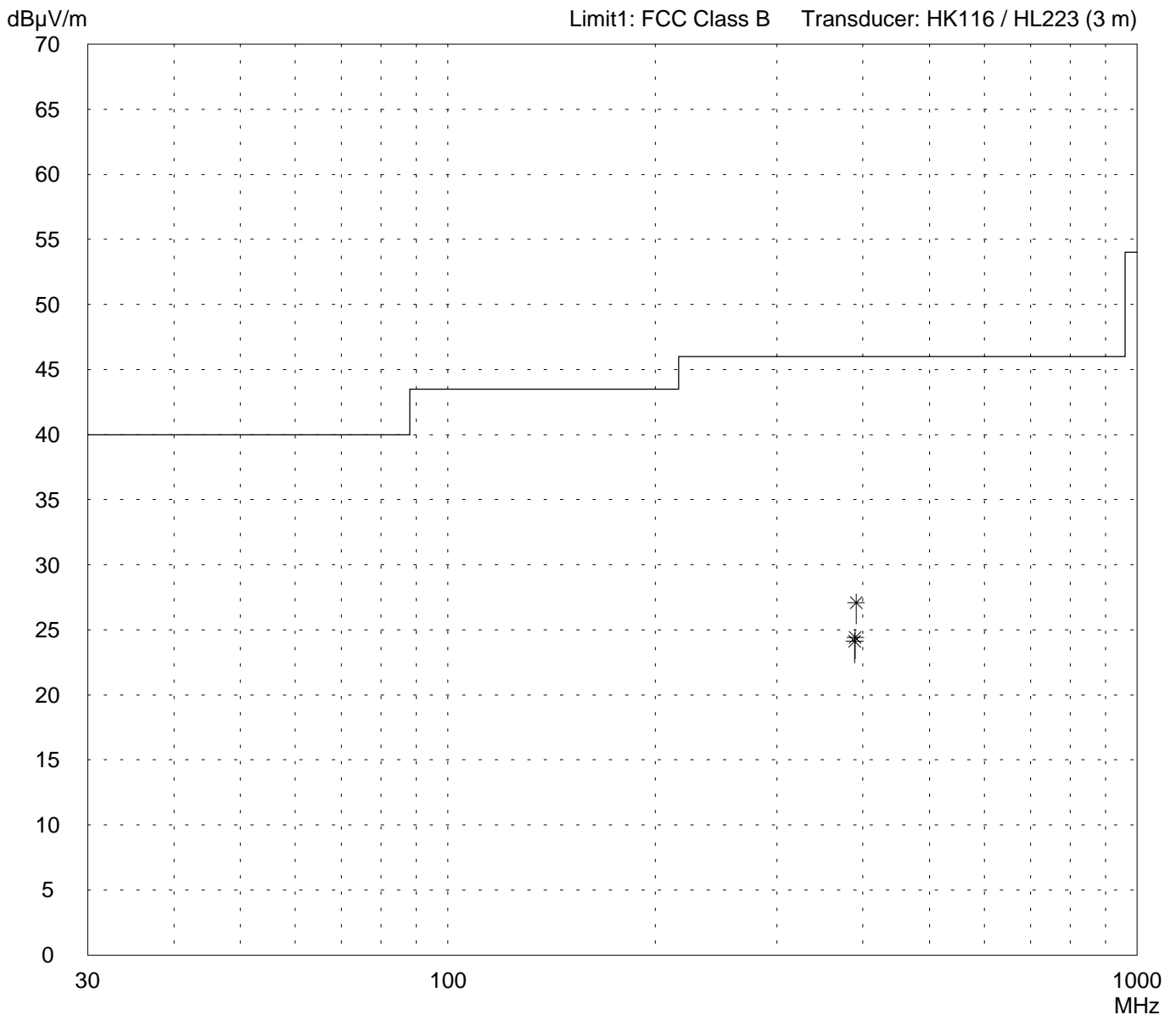

Result: Limit kept

Project file: 50530-10437	Page 35 of 40 Pages
------------------------------	---------------------

**Radiated Emission Test 30 MHz - 1 GHz
according to FCC Part 15 Subpart B Class B**

Model:
RCI01-340 (390 MHz)

Serial no.:
--

Applicant:
Eldat GmbH

Test site:
Open area test-site I

Tested on:
Test distance 3 metres
Vertical Polarization

Date of test: 06/29/2001 Operator: T. Eberl

Test performed: by hand File name:

Mode:
- RX mode

-EUT AC powered 24 V

Detector:
Quasi-Peak

List of values:
Selected by hand

<i>Frequency MHz</i>	<i>Reading dBµV</i>	<i>Correction factor dB</i>	<i>Value dBµV/m</i>	<i>Limit dBµV/m</i>	<i>Limit exceeded</i>
389.0	2.0	22.1	24.1	46.0	
390.0	2.3	22.1	24.4	46.0	
391.0	5.0	22.1	27.1	46.0	

Result:
Limit kept

Project file:
50530-10437

Page 36 of 40 Pages

Radiated Emission Test 1 GHz - 2 GHz according to FCC Part 15 Subpart B Class B

Model: RCI01-340 (390 MHz)	
Serial no.: --	
Applicant: Eldat GmbH	
Test site: Semi anechoic room, cabin no. 3	
Tested on: Test distance 3 metres Horizontal Polarization	
Date of test: 06/29/2001	Operator: T. Eberl
Test performed: automatically	File name:

Mode: - RX mode -EUT AC powered 24 V
--

Detector: Peak

List of values: 10 dB Margin	50 Subranges
---------------------------------	--------------

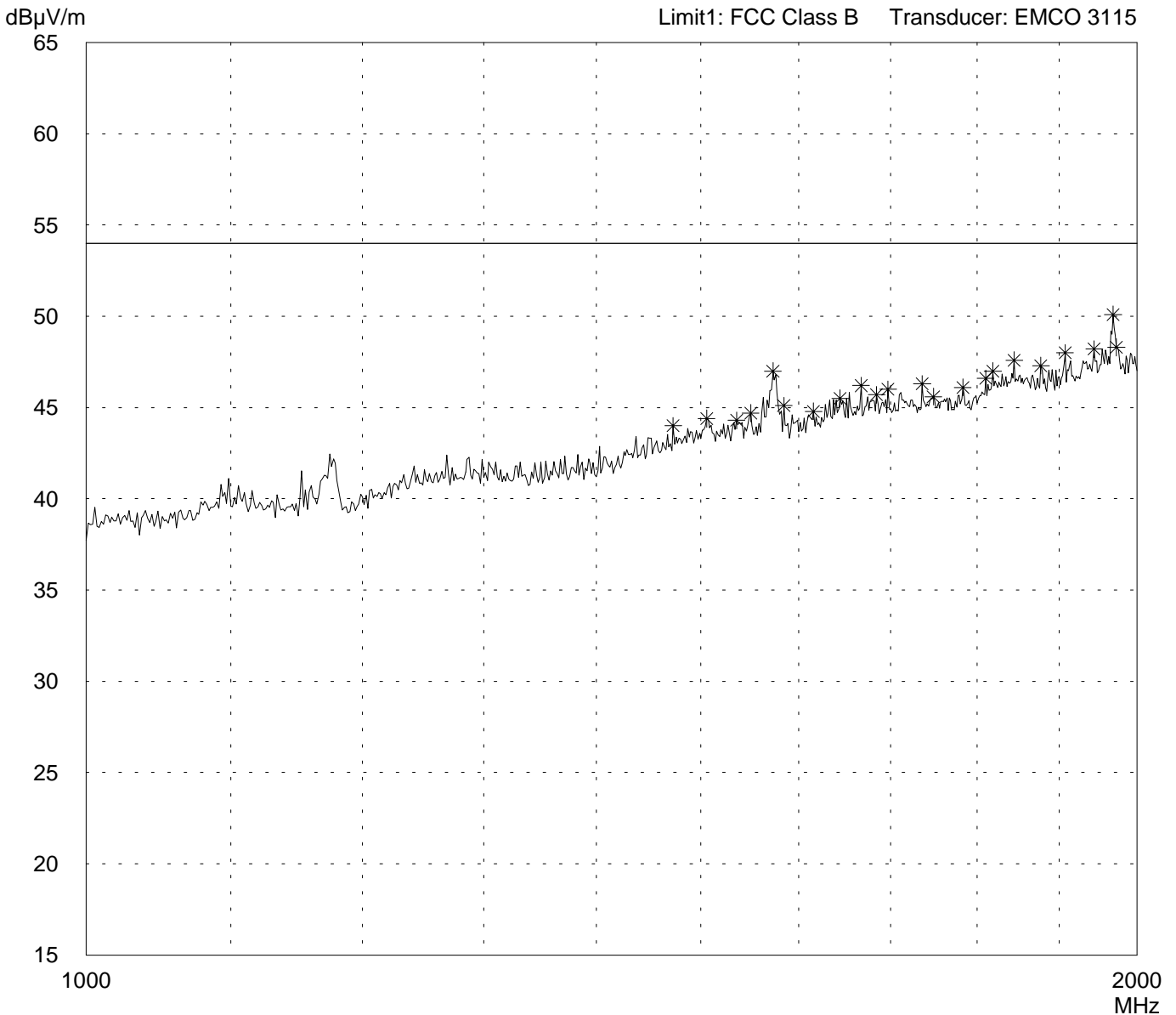

Result: Limit kept

Project file: 50530-10437	Page 37 of 40 Pages
------------------------------	---------------------

Radiated Emission Test 1 GHz - 2 GHz according to FCC Part 15 Subpart B Class B

<p>Model: RCI01-340 (390 MHz)</p> <p>Serial no.: --</p> <p>Applicant: Eldat GmbH</p> <p>Test site: Semi anechoic room, cabin no. 3</p> <p>Tested on: Test distance 3 metres Horizontal Polarization</p> <p>Date of test: Operator: 06/29/2001 T. Eberl</p> <p>Test performed: File name: automatically</p>	<p>Mode: - RX mode</p> <p>-EUT AC powered 24 V</p>
--	--

<p>Detector: Peak</p>	<p>List of values: 10 dB Margin 50 Subranges</p>
---------------------------	---

<i>Frequency MHz</i>	<i>Reading dBμV</i>	<i>Correction factor dB</i>	<i>Value dBμV/m</i>	<i>Limit dBμV/m</i>	<i>Limit exceeded</i>
1472.86	7.1	36.9	44.0	54.0	
1505.71	7.2	37.2	44.4	54.0	
1535.71	6.8	37.5	44.3	54.0	
1550.00	7.1	37.6	44.7	54.0	
1572.86	9.2	37.8	47.0	54.0	
1584.29	7.2	37.9	45.1	54.0	
1615.71	6.6	38.2	44.8	54.0	
1644.29	7.0	38.5	45.5	54.0	
1667.14	7.5	38.7	46.2	54.0	
1684.29	6.8	38.9	45.7	54.0	
1697.14	7.0	39.0	46.0	54.0	
1735.71	7.0	39.3	46.3	54.0	
1748.57	6.2	39.4	45.6	54.0	
1782.86	6.4	39.7	46.1	54.0	
1810.00	6.6	40.0	46.6	54.0	
1818.57	7.0	40.0	47.0	54.0	
1844.29	7.3	40.3	47.6	54.0	
1877.14	6.8	40.5	47.3	54.0	
1907.14	7.2	40.8	48.0	54.0	
1944.29	7.1	41.1	48.2	54.0	
1968.57	8.8	41.3	50.1	54.0	
1972.86	7.0	41.3	48.3	54.0	

<p>Result: Limit kept</p>	<p>Project file: 50530-10437</p> <p style="text-align: right;">Page 38 of 40 Pages</p>
-------------------------------	--

Radiated Emission Test 1 GHz - 2 GHz according to FCC Part 15 Subpart B Class B

Model: RCI01-340 (390 MHz)	
Serial no.: --	
Applicant: Eldat GmbH	
Test site: Semi anechoic room, cabin no. 3	
Tested on: Test distance 3 metres Vertical Polarization	
Date of test: 06/29/2001	Operator: T. Eberl
Test performed: automatically	File name:

Mode: - RX mode	
-EUT AC powered 24 V	

Detector: Peak

List of values: 10 dB Margin	50 Subranges
---------------------------------	--------------

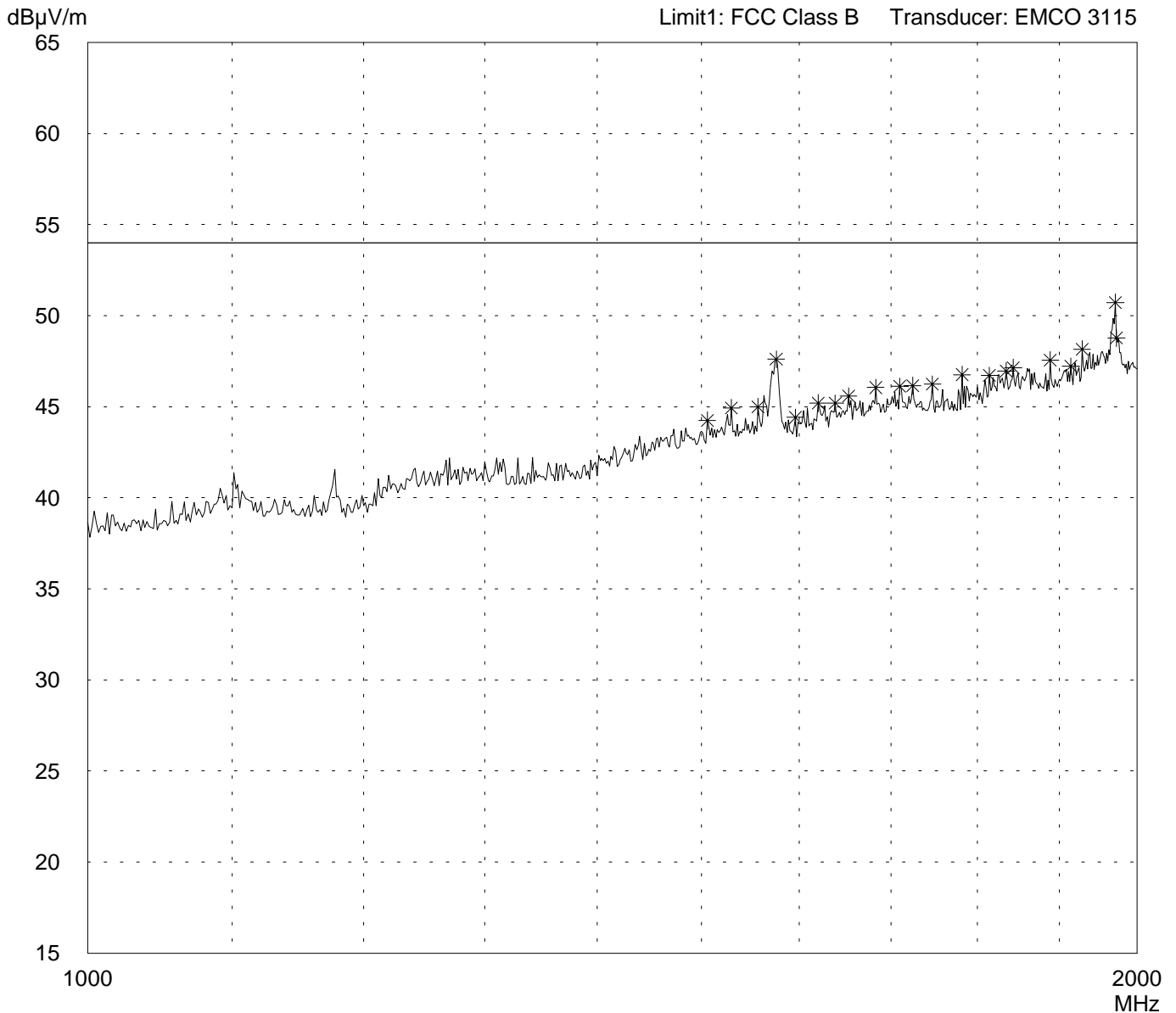

Result: Limit kept

Project file: 50530-10437	Page 39 of 40 Pages
------------------------------	---------------------

Radiated Emission Test 1 GHz - 2 GHz according to FCC Part 15 Subpart B Class B

<p>Model: RCI01-340 (390 MHz)</p> <p>Serial no.: --</p> <p>Applicant: Eldat GmbH</p> <p>Test site: Semi anechoic room, cabin no. 3</p> <p>Tested on: Test distance 3 metres Vertical Polarization</p> <p>Date of test: Operator: 06/29/2001 T. Eberl</p> <p>Test performed: File name: automatically</p>	<p>Mode: - RX mode</p> <p>-EUT AC powered 24 V</p>
--	--

<p>Detector: Peak</p>	<p>List of values: 10 dB Margin 50 Subranges</p>
---------------------------	---

<i>Frequency MHz</i>	<i>Reading dBμV</i>	<i>Correction factor dB</i>	<i>Value dBμV/m</i>	<i>Limit dBμV/m</i>	<i>Limit exceeded</i>
1505.71	7.1	37.2	44.3	54.0	
1530.00	7.5	37.4	44.9	54.0	
1557.14	7.3	37.7	45.0	54.0	
1575.71	9.7	37.9	47.6	54.0	
1595.71	6.4	38.0	44.4	54.0	
1620.00	6.9	38.3	45.2	54.0	
1638.57	6.7	38.5	45.2	54.0	
1652.86	7.0	38.6	45.6	54.0	
1682.86	7.2	38.9	46.1	54.0	
1710.00	7.0	39.1	46.1	54.0	
1724.29	7.0	39.2	46.2	54.0	
1747.14	6.8	39.4	46.2	54.0	
1781.43	7.1	39.7	46.8	54.0	
1814.29	6.7	40.0	46.7	54.0	
1834.29	6.8	40.2	47.0	54.0	
1842.86	6.9	40.2	47.1	54.0	
1888.57	7.0	40.6	47.6	54.0	
1914.29	6.4	40.8	47.2	54.0	
1928.57	7.3	40.9	48.2	54.0	
1971.43	9.4	41.3	50.7	54.0	
1972.86	7.5	41.3	48.8	54.0	

<p>Result: Limit kept</p>	<p>Project file: 50530-10437</p> <p style="text-align: right;">Page 40 of 40 Pages</p>
-------------------------------	--