





TEST REPORT FROM RADIO FREQUENCY INVESTIGATION LTD.

Test Of:
Red-M (Communications) Ltd.
Smart Wireless Access Server
To: FCC Part 15 Subpart C: 2000
(Intentional Radiators)
Section 15.247
(Requested Parts Only)

Test Report Serial No: RFI/MPTB2/RP43166A

This Test Report supersedes RFI Test Report No.:
RFI/MPTB1/RP43166A

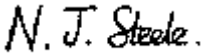
This Test Report Is Issued Under The Authority Of Richard Jacklin, Operations Director: 	Checked By: 
Tested By: 	Release Version No: PDF01
Issue Date: 14 March 2002	Test Dates: 19 February 2002 to 25 February 2002

This report is issued in Adobe Acrobat portable document format (PDF). It is only a valid copy of the report if it is being viewed in PDF format with the following security options not allowed: Changing the document, Selecting text and graphics, Adding or changing notes and form fields. Furthermore, the date of creation must match the issue date stated above. This report may be copied in full. The results in this report apply only to the sample(s) tested.

Radio Frequency Investigation Ltd, Ewhurst Park, Ramsdell, Basingstoke, Hampshire, RG26 5RQ, ENGLAND. Tel: +44 (0) 1256 851193 Fax: +44 (0) 1256 851192	Registered in England, No. 211 7901. Registered Office: Ewhurst Park, Ramsdell, Basingstoke, Hampshire RG26 5RQ	
---	---	---

RADIO FREQUENCY INVESTIGATION LTD.

TEST REPORT

EMC Department

S.No: RFI/MPTB2/RP43166A

Page 2 of 34

Issue Date: 14 March 2002

Test Of: Red-M (Communications) Ltd.

Smart Wireless Access Server

To: FCC Part 15 Subpart C: 2000 (Intentional Radiators)

Section 15.247

(Requested Parts Only)

This page has been left intentionally blank.

Test Of: Red-M (Communications) Ltd.
Smart Wireless Access Server
To: FCC Part 15 Subpart C: 2000 (Intentional Radiators)
Section 15.247
(Requested Parts Only)

Table of Contents

1. Client Information	4
2. Equipment Under Test (EUT).....	5
3. Test Specification, Methods And Procedures	8
4. Deviations From The Test Specification.....	10
5. Operation Of The EUT During Testing	11
6. Summary Of Test Results.....	12
7. Measurements, Examinations And Derived Results.....	13
8. Measurement Uncertainty.....	27
Appendix 1. Test Equipment Used.....	28
Appendix 2. Measurement Methods	29
Appendix 3. Test Configuration Drawings	31

**Test Of: Red-M (Communications) Ltd.
Smart Wireless Access Server**

**To: FCC Part 15 Subpart C: 2000 (Intentional Radiators)
Section 15.247
(Requested Parts Only)**

1. Client Information

Company Name:	Red-M (Communications) Ltd.
Address:	Wexham Springs Framewood Road Wexham Slough SL3 6PJ.
Contact Name:	Mark Bailey

Test Of: Red-M (Communications) Ltd.
Smart Wireless Access Server
To: FCC Part 15 Subpart C: 2000 (Intentional Radiators)
Section 15.247
(Requested Parts Only)

2. Equipment Under Test (EUT)

The following information (with the exception of the Date of Receipt) has been supplied by the client:

2.1. Identification Of Equipment Under Test (EUT)

Brand Name:	Red-M
Model Name or Number:	Smart Wireless Access Server
Unique Type Identification:	Not Stated By Client
Serial Number:	Not Stated By Client
Country of Manufacture:	UK
FCC ID Number:	None stated
Date of Receipt:	19 February 2002

2.2. Description Of EUT

The equipment under test is a Bluetooth Access Server. It provides connectivity between Bluetooth devices, LAN and WAN.

2.3. Modifications Incorporated In EUT

The EUT has not been modified from what is described by the Model Name stated above.

**Test Of: Red-M (Communications) Ltd.
Smart Wireless Access Server**
**To: FCC Part 15 Subpart C: 2000 (Intentional Radiators)
Section 15.247
(Requested Parts Only)**

2.4. Additional Information Related To Testing

Power Supply Requirement:	115 V, 60 Hz AC Mains supply
Intended Operating Environment:	Commercial, Light Industry
Weight:	3.8 kg
Dimensions:	245 x 145 x 334
Interface Ports:	RS232 (x2) 10/100 Fast Ethernet (x3) AC Mains Input ISDN BRI S-i/f External Antenna

Test Of: Red-M (Communications) Ltd.
Smart Wireless Access Server

To: FCC Part 15 Subpart C: 2000 (Intentional Radiators)
Section 15.247
(Requested Parts Only)

2.5. Support Equipment

The following support equipment was used to exercise the EUT during testing:

Description:	10/100 Switch
Brand Name:	3COM
Model Name or Number:	3 Com Office Connect Dual Speed Hub 8
Serial Number:	0101/7P1F67471
FCC ID Number:	None stated
Cable Length And Type:	3m, 10/100 Type
Connected to Port:	10/100

Description: (as used in schematic)	Personal Computer
Brand Name:	Dell
Model Name or Number:	Latitude CP M233XT
Serial Number:	0009321C-12800-840-2517
FCC ID Number:	None given.
Cable Length And Type:	2m power, 1m CAT 5 UTP
Connected to Port:	Power input, Ethernet port

Test Of: Red-M (Communications) Ltd.
Smart Wireless Access Server

To: FCC Part 15 Subpart C: 2000 (Intentional Radiators)
Section 15.247
(Requested Parts Only)

3. Test Specification, Methods And Procedures

3.1. Test Specification

Reference:	FCC Part 15 Subpart C: 2000 (Section 15.247, 15.205, 15.209 and 15.109)
Title:	Code of Federal Regulations, Part 15 (47CFR15) Radio Frequency Devices: Digital Devices.
Comments:	A description of the test facility used for this test is on file with, and has been accepted by, the Federal Communications Commission as required by Section 2.948 of Federal Rules.
Purpose of Test:	To determine whether the equipment complied with the requirements of the specification for the purposes of certification.

Test Of: Red-M (Communications) Ltd.
Smart Wireless Access Server

To: FCC Part 15 Subpart C: 2000 (Intentional Radiators)
Section 15.247
(Requested Parts Only)

3.2. Methods And Procedures

The methods and procedures used were as detailed in:

FCC Code of Federal Regulations 47.
Telecommunication. Part 15, October 2000.

ANSI C63.2 (1987)

Title: American National Standard for Instrumentation - Electromagnetic noise and field strength.

ANSI C63.4 (2001)

Title: American National Standard Methods of Measurement of Electromagnetic Emissions from Low Voltage Electrical and Electronic Equipment in the Range of 9 kHz to 40 GHz.

ANSI C63.5 (1988)

Title: American National Standard for the Calibration of antennas used for Radiated Emission measurements in Electromagnetic Interference (EMI) control.

ANSI C63.7 (1988)

Title: American National Standard Guide for Construction of Open Area Test Sites for performing Radiated Emission Measurements.

CISPR 16-1: (1999)

Title: Specification For Radio Disturbance and Immunity Measuring Apparatus and Methods. Part 1: Radio Disturbance and Immunity Measuring Apparatus.

3.3. Definition Of Measurement Equipment

The measurement equipment used complied with the requirements of the standards referenced in the Methods & Procedures section above. Appendix 1 contains a list of the test equipment used.

RADIO FREQUENCY INVESTIGATION LTD.

TEST REPORT

EMC Department

S.No: RFI/MPTB2/RP43166A

Page 10 of 34

Issue Date: 14 March 2002

Test Of: Red-M (Communications) Ltd.
Smart Wireless Access Server

To: FCC Part 15 Subpart C: 2000 (Intentional Radiators)
Section 15.247
(Requested Parts Only)

4. Deviations From The Test Specification

None.

Test Of: Red-M (Communications) Ltd.
Smart Wireless Access Server

To: FCC Part 15 Subpart C: 2000 (Intentional Radiators)
Section 15.247
(Requested Parts Only)

5. Operation Of The EUT During Testing

5.1. Operating Conditions

The EUT was tested in a normal laboratory environment.

During testing, the EUT was powered by a 115 V, 60 Hz AC Mains supply.

5.2. Operating Modes

The EUT was tested in the following operating modes:

1: Test Mode: The EUT operated in a test mode with its channels Fixed either on Top, Bottom or Middle channel, as specified in FCC Part 15.31(m) and FCC Public Notice DA 00-705.

2: Receive Mode: The EUT did not transmit on any channels but received on all hopping frequencies.

The reason for choosing these modes was that it was defined by the client as being likely to be the worst case with regards EMC.

5.3. Configuration And Peripherals

The EUT was configured, connected to the relevant support equipment as shown in the diagram given in Appendix 3 of this test report.

NB Section 2 of this report contains a full list of support equipment used.

Test Of: Red-M (Communications) Ltd.
Smart Wireless Access Server

To: FCC Part 15 Subpart C: 2000 (Intentional Radiators)
Section 15.247
(Requested Parts Only)

6. Summary Of Test Results

6.1. Emissions: Transmit Mode

Range Of Measurements	Specification Reference	Compliance Status
Radiated Electric Field Strength Spurious Emissions (30 to 26000 MHz)	C.F.R. 47 FCC Part 15: 2000. Section 15.247 (c) (15.209)	Complied

6.2. Emissions: Receive Mode

Range Of Measurements	Specification Reference	Compliance Status
Radiated Electric Field Strength Spurious Emissions (30 to 26000 MHz)	C.F.R. 47 FCC Part 15: 2000. Section 15.109	Complied

6.3. Location Of Tests

All the measurements described in this report were performed at the premises of Radio Frequency Investigation Ltd, Ewhurst Park, Ramsdell, Basingstoke, Hampshire, RG26 5RQ, England.

Test Of: Red-M (Communications) Ltd.
Smart Wireless Access Server

To: FCC Part 15 Subpart C: 2000 (Intentional Radiators)
Section 15.247
(Requested Parts Only)

7. Measurements, Examinations And Derived Results

7.1. General Comments

7.1.1. This section contains test results only. Details of the test methods and procedures can be found in Appendix 2 of this report.

7.1.2. Measurement uncertainties are evaluated in accordance with current best practice. Our reported expanded uncertainties are based on standard uncertainties, which are multiplied by an appropriate coverage factor to provide a statistical confidence level of approximately 95%. Please refer to Section 8 for details of measurement uncertainties.

Test Of: Red-M (Communications) Ltd.
Smart Wireless Access Server

To: FCC Part 15 Subpart C: 2000 (Intentional Radiators)
Section 15.247
(Requested Parts Only)

7.2. Test Results For Radiated Emissions: Transmit Mode

7.2.1. Electric Field Strength Measurements: 30 to 1000 MHz

7.2.1.1. The following table specifies frequencies, which fall close to the restricted bands as specified in section FCC Part 15.205.

7.2.1.2. Preliminary Radiated spurious scans were performed with the EUT set to Top, Middle and Bottom as stated in section 5.2.

7.2.1.3. Plots of the initial scans can be found in Appendix 4.

7.2.1.4. The following table lists frequencies at which emissions were measured using a Quasi-Peak detector at a test distance of 3m (results incorporate antenna factors and cable losses):

Bottom Channel

Frequency (MHz)	Ant. Pol.	Q-P Level (dBmV/m)	Limit (dBmV/m)	Margin (dB)	Result
45.879	Vert.	21.1	40.0	18.9	Complied
48.417	Vert.	26.4	40.0	13.6	Complied
66.244	Vert.	26.1	40.0	13.9	Complied
124.984	Vert.	27.1	43.5	16.4	Complied
528.013	Vert.	43.8	46.0	2.2	Complied
560.995	Vert.	32.0	46.0	14.0	Complied
597.453	Horiz.	20.3	46.0	25.7	Complied
660.017	Horiz.	37.8	46.0	8.2	Complied (Note 1)

Note 1: Due to the presence of an ambient signal this emission was re-measured using a substitution method. At the emission frequency a high level signal was generated in the screened room used for the initial swept measurements. This measurement was then repeated on the open area test site. The difference in amplitude between the screened room measurement and free-field measurement was then used to correct the value obtained in the screened room for the test sample.

Test Of: Red-M (Communications) Ltd.
Smart Wireless Access Server
To: FCC Part 15 Subpart C: 2000 (Intentional Radiators)
Section 15.247
(Requested Parts Only)

Test Results For Radiated Emissions: Transmit Mode (30 to 1000 MHz)
(continued)

Middle Channel

Frequency (MHz)	Ant. Pol.	Q-P Level (dBmV/m)	Limit (dBmV/m)	Margin (dB)	Result
46.116	Vert.	19.5	40.0	20.5	Complied
48.406	Vert.	27.9	40.0	12.1	Complied
66.280	Vert.	26.0	40.0	14.0	Complied
104.113	Vert.	27.9	40.0	12.1	Complied (Note 1)
124.993	Vert.	21.6	43.5	21.9	Complied
145.230	Vert.	19.2	43.5	24.3	Complied
351.980	Horiz.	17.5	46.0	28.5	Complied
530.200	Horiz.	28.2	46.0	17.8	Complied
565.653	Vert.	23.3	46.0	22.7	Complied
579.960	Horiz.	29.3	46.0	16.7	Complied
659.996	Horiz.	21.1	46.0	24.9	Complied

Note 1: Due to the presence of an ambient signal this emission was re-measured using a substitution method. At the emission frequency a high level signal was generated in the screened room used for the initial swept measurements. This measurement was then repeated on the open area test site. The difference in amplitude between the screened room measurement and free-field measurement was then used to correct the value obtained in the screened room for the test sample.

Test Of: Red-M (Communications) Ltd.
Smart Wireless Access Server

To: FCC Part 15 Subpart C: 2000 (Intentional Radiators)
Section 15.247
(Requested Parts Only)

Test Results For Radiated Emissions: Transmit Mode (30 to 1000 MHz)
(continued)

Top Channel

Frequency (MHz)	Ant. Pol.	Q-P Level (dBmV/m)	Limit (dBmV/m)	Margin (dB)	Result
45.760	Vert.	25.5	40.0	14.5	Complied
45.906	Vert.	22.8	40.0	17.2	Complied
66.271	Vert.	26.0	40.0	14.0	Complied
104.762	Vert.	16.7	43.5	26.8	Complied (Note 1)
125.000	Vert.	30.2	43.5	13.3	Complied
194.040	Vert.	10.3	43.5	33.2	Complied
351.977	Horiz.	18.3	46.0	27.8	Complied
530.231	Horiz.	26.0	46.0	20.0	Complied
561.013	Horiz.	34.2	46.0	11.8	Complied
597.446	Horiz.	20.3	46.0	25.7	Complied
659.982	Vert.	45.8	46.0	0.2	Complied (Note 1)

Note 1: Due to the presence of an ambient signal this emission was re-measured using a substitution method. At the emission frequency a high level signal was generated in the screened room used for the initial swept measurements. This measurement was then repeated on the open area test site. The difference in amplitude between the screened room measurement and free-field measurement was then used to correct the value obtained in the screened room for the test sample.

Test Of: Red-M (Communications) Ltd.
Smart Wireless Access Server
To: FCC Part 15 Subpart C: 2000 (Intentional Radiators)
Section 15.247
(Requested Parts Only)

7.3. Test Results For Radiated Emissions: Transmit Mode (Bottom Channel)

7.3.1. Electric Field Strength Measurements: 1.0 to 26.0 GHz

7.3.1.1. The following table specifies frequencies, which fall within the bands as specified in section 15.205.

7.3.1.2. The client has stated that the highest clock frequency for the EUT was 2.480 GHz. Therefore tests were performed up to 26 GHz.

7.3.1.3. Preliminary Radiated spurious scans were performed with the EUT set to Bottom, Middle and Top channels as stated in section 5.2.

7.3.1.4. Plots of all the initial scans can be found in Appendix 4.

7.3.1.5. The following table lists frequencies at which emissions were measured using an Average and Peak detector, a measurement test distance of 3 meters was used for the indicated results (results incorporate antenna factors and cable losses):

Highest Average Level:

Frequency (GHz)	Antenna Polarity (H/V)	Average Detector level (dBmV)	Antenna factor (dB)	Cable loss (dB)	Actual Average Level (dBmV/m)	Average Limit (dBmV/m)	Average Margin (dB)	Result
1022.971	Horiz.	15.5	21.5	0.9	37.9	54.0	16.1	Complied
1055.720	Vert.	15.6	21.5	0.9	38.0	54.0	16.0	Complied
1088.701	Vert.	15.9	21.5	0.9	38.3	54.0	15.7	Complied
2306.061	Vert.	20.5	20.0	1.9	42.4	54.0	11.6	Complied
2338.017	Vert.	21.0	20.0	1.9	42.9	54.0	11.1	Complied
2497.954	Vert.	21.3	20.0	1.9	43.2	54.0	10.8	Complied

Test Of: Red-M (Communications) Ltd.
Smart Wireless Access Server

To: FCC Part 15 Subpart C: 2000 (Intentional Radiators)
Section 15.247
(Requested Parts Only)

Test Results For Radiated Emissions: Transmit Mode (1.0 to 26.0 GHz)
(Bottom Channel) (continued)

Highest Peak Level:

Frequency (GHz)	Antenna Polarity (H/V)	Peak Detector level (dBmV)	Antenna factor (dB)	Cable loss (dB)	Actual Peak Level (dBmV/m)	Peak Limit (dBmV/m)	Peak Margin (dB)	Result
1022.971	Horiz.	26.9	21.5	0.9	49.3	74.0	24.7	Complied
1055.720	Vert.	26.9	21.5	0.9	49.3	74.0	54.7	Complied
1088.701	Vert.	35.9	21.5	0.9	58.3	74.0	15.7	Complied
2306.061	Vert.	31.3	20.0	1.9	53.2	74.0	20.8	Complied
2338.017	Vert.	31.6	20.0	1.9	53.5	74.0	20.5	Complied
2497.954	Vert.	32.0	20.0	1.9	53.9	74.0	20.1	Complied

Test Of: Red-M (Communications) Ltd.
Smart Wireless Access Server
To: FCC Part 15 Subpart C: 2000 (Intentional Radiators)
Section 15.247
(Requested Parts Only)

7.4. Test Results For Radiated Emissions: Transmit Mode (Middle Channel)

7.4.1. Electric Field Strength Measurements: 1.0 to 26.0 GHz

7.4.1.1. The following table specifies frequencies, which fall within the bands as specified in section 15.205.

7.4.1.2. The client has stated that the highest clock frequency for the EUT was 2.480 GHz. Therefore tests were performed up to 26 GHz.

7.4.1.3. Preliminary Radiated spurious scans were performed with the EUT set to Bottom, Middle and Top channels as stated in section 5.2.

7.4.1.4. Plots of all the initial scans can be found in Appendix 4.

7.4.1.5. The following table lists frequencies at which emissions were measured using an Average and Peak detector, a measurement test distance of 3 meters was used for the indicated results (results incorporate antenna factors and cable losses):

Highest Average Level:

Frequency (GHz)	Antenna Polarity (H/V)	Average Detector level (dBmV)	Antenna factor (dB)	Cable loss (dB)	Actual Average Level (dBmV/m)	Average Limit (dBmV/m)	Average Margin (dB)	Result
1022.971	Horiz.	15.5	21.5	0.9	37.9	54.0	16.1	Complied
1055.720	Vert.	15.6	21.5	0.9	38.0	54.0	16.0	Complied
1088.701	Vert.	15.9	21.5	0.9	38.3	54.0	15.7	Complied
2504.913	Vert.	22.2	20.0	1.9	44.1	54.0	9.9	Complied
2536.901	Vert.	20.9	20.0	1.9	42.8	54.0	11.2	Complied
2601.124	Vert.	20.1	20.0	1.9	42.0	54.0	12.0	Complied

Test Of: Red-M (Communications) Ltd.
Smart Wireless Access Server

To: FCC Part 15 Subpart C: 2000 (Intentional Radiators)
Section 15.247
(Requested Parts Only)

Test Results For Radiated Emissions: Transmit Mode (1.0 to 26.0 GHz)
(Middle Channel) (continued)

Highest Peak Level:

Frequency (GHz)	Antenna Polarity (H/V)	Peak Detector level (dBmV)	Antenna factor (dB)	Cable loss (dB)	Actual Peak Level (dBmV/m)	Peak Limit (dBmV/m)	Peak Margin (dB)	Result
1022.971	Horiz.	26.9	21.5	0.9	49.3	74.0	24.7	Complied
1055.720	Vert.	26.9	21.5	0.9	49.3	74.0	24.7	Complied
1088.701	Vert.	35.9	21.5	0.9	58.3	74.0	15.7	Complied
2504.913	Vert.	32.3	20.0	1.9	54.2	74.0	19.8	Complied
2536.901	Vert.	31.3	20.0	1.9	53.2	74.0	20.8	Complied
2601.124	Vert.	31.5	20.0	1.9	53.4	74.0	20.6	Complied

Test Of: Red-M (Communications) Ltd.
Smart Wireless Access Server

To: FCC Part 15 Subpart C: 2000 (Intentional Radiators)
Section 15.247
(Requested Parts Only)

7.5. Test Results For Radiated Emissions: Transmit Mode (Top Channel)

7.5.1. Electric Field Strength Measurements: 1.0 to 26.0 GHz

7.5.1.1. The following table specifies frequencies, which fall within the bands as specified in section 15.205.

7.5.1.2. The client has stated that the highest clock frequency for the EUT was 2.480 GHz. Therefore tests were performed up to 26 GHz.

7.5.1.3. Preliminary Radiated spurious scans were performed with the EUT set to Bottom, Middle and Top channels as stated in section 5.2.

7.5.1.4. Plots of all the initial scans can be found in Appendix 4.

7.5.1.5. The following table lists frequencies at which emissions were measured using an Average and Peak detector, a measurement test distance of 3 meters was used for the indicated results (results incorporate antenna factors and cable losses):

Highest Average Level:

Frequency (GHz)	Antenna Polarity (H/V)	Average Detector level (dBmV)	Antenna factor (dB)	Cable loss (dB)	Actual Average Level (dBmV/m)	Average Limit (dBmV/m)	Average Margin (dB)	Result
1022.971	Horiz.	15.5	21.5	0.9	37.9	54.0	16.1	Complied
1055.720	Vert.	15.6	21.5	0.9	38.0	54.0	16.0	Complied
1088.701	Vert.	15.9	21.5	0.9	38.3	54.0	15.7	Complied
2512.004	Vert.	22.3	20.0	1.9	44.2	54.0	9.8	Complied
2543.986	Vert.	22.6	20.0	1.9	44.5	54.0	9.5	Complied

Test Of: Red-M (Communications) Ltd.
Smart Wireless Access Server

To: FCC Part 15 Subpart C: 2000 (Intentional Radiators)
Section 15.247
(Requested Parts Only)

Test Results For Radiated Emissions: Transmit Mode (1.0 to 26.0 GHz)
(Top Channel) (continued)

Highest Peak Level:

Frequency (GHz)	Antenna Polarity (H/V)	Peak Detector level (dBmV)	Antenna factor (dB)	Cable loss (dB)	Actual Peak Level (dBmV/m)	Peak Limit (dBmV/m)	Peak Margin (dB)	Result
1022.971	Horiz.	26.9	21.5	0.9	49.3	74.0	24.7	Complied
1055.720	Vert.	26.9	21.5	0.9	49.3	74.0	24.7	Complied
1088.701	Vert.	35.9	21.5	0.9	58.3	74.0	15.7	Complied
2512.004	Vert.	32.0	20.0	1.9	53.9	74.0	20.1	Complied
2543.986	Vert.	32.3	20.0	1.9	54.2	74.0	19.8	Complied

Test Of: Red-M (Communications) Ltd.
Smart Wireless Access Server
To: FCC Part 15 Subpart C: 2000 (Intentional Radiators)
Section 15.247
(Requested Parts Only)

7.6. Test Results For Radiated Emissions: Receive Mode

7.6.1. Electric Field Strength Measurements (Frequency Range: 30 to 1000 MHz)

7.6.1.1. The following table indicates measured results with the EUT operated in receive mode to the limits specified in Part 15.109.

7.6.1.2. Plots of the initial scans can be found in Appendix 4.

7.6.1.3. The following table lists frequencies at which emissions were measured using a Quasi-Peak detector at a test distance of 3m (results incorporate antenna factors and cable losses):

Frequency (MHz)	Ant. Pol.	Q-P Level (dBmV/m)	Limit (dBmV/m)	Margin (dB)	Result
45.800	Vert.	30.4	40.0	9.6	Complied
45.937	Vert.	29.6	40.0	10.4	Complied
66.422	Vert.	17.1	40.0	22.9	Complied
124.993	Vert.	28.5	43.5	15.0	Complied
127.975	Vert.	14.8	43.5	28.7	Complied
194.040	Vert.	9.3	43.5	34.2	Complied
480.002	Horiz.	28.8	46.0	17.2	Complied
515.991	Horiz.	25.6	46.0	20.4	Complied
530.202	Horiz.	30.6	46.0	15.4	Complied
563.393	Horiz.	30.1	46.0	15.9	Complied
596.313	Horiz.	21.7	46.0	24.3	Complied
660.004	Vert.	37.9	46.0	8.1	Complied (Note 1)
662.760	Vert.	41.5	46.0	4.5	Complied (Note 1)

Note 1: Due to the presence of an ambient signal this emission was re-measured using a substitution method. At the emission frequency a high level signal was generated in the screened room used for the initial swept measurements. This measurement was then repeated on the open area test site. The difference in amplitude between the screened room measurement and free-field measurement was then used to correct the value obtained in the screened room for the test sample.

Test Of: Red-M (Communications) Ltd.
Smart Wireless Access Server
To: FCC Part 15 Subpart C: 2000 (Intentional Radiators)
Section 15.247
(Requested Parts Only)

Test Results For Radiated Emissions: Receive Mode (continued)

7.6.2. Electric Field Strength Measurements (Frequency Range: 1.0 to 26.0 GHz)

7.6.2.1. The following table indicates measured results with the EUT operated in receive mode to the limits specified in Part 15.109.

7.6.2.2. Plots of all the initial scans can be found in Appendix 4.

Highest Average Level:

Frequency (GHz)	Antenna Polarity (H/V)	Average Detector level (dBmV)	Antenna factor (dB)	Cable loss (dB)	Actual Average Level (dBmV/m)	Average Limit (dBmV/m)	Average Margin (dB)	Result
1022.971	Horiz.	15.5	21.5	0.9	37.9	54.0	16.1	Complied
1055.720	Vert.	15.6	21.5	0.9	38.0	54.0	16.0	Complied
1088.701	Vert.	15.9	21.5	0.9	38.3	54.0	15.7	Complied

Highest Peak Level:

Frequency (GHz)	Antenna Polarity (H/V)	Peak Detector level (dBmV)	Antenna factor (dB)	Cable loss (dB)	Actual Peak Level (dBmV/m)	Peak Limit (dBmV/m)	Peak Margin (dB)	Result
1022.971	Horiz.	26.9	21.5	0.9	49.3	74.0	24.7	Complied
1055.720	Vert.	26.9	21.5	0.9	49.3	74.0	24.7	Complied
1088.701	Vert.	35.9	21.5	0.9	58.3	74.0	15.7	Complied

Test Of: Red-M (Communications) Ltd.
Smart Wireless Access Server
To: FCC Part 15 Subpart C: 2000 (Intentional Radiators)
Section 15.247
(Requested Parts Only)

7.7. Test Results For Radiated Emissions: Hopping Mode

7.7.1. Electric Field Strength Measurements (Frequency Range: 30 to 1000 MHz)

7.7.1.1. The following table indicates measured results with the EUT operated in Hopping mode.

7.7.1.2. Plots of the initial scans can be found in Appendix 4.

7.7.1.3. The following table lists frequencies at which emissions were measured using a Quasi-Peak detector at a test distance of 3m (results incorporate antenna factors and cable losses):

Frequency (MHz)	Ant. Pol.	Q-P Level (dBmV/m)	Limit (dBmV/m)	Margin (dB)	Result
46.044	Vert.	10.7	40.0	29.3	Complied
48.426	Vert.	16.6	40.0	23.4	Complied
57.100	Vert.	15.8	40.0	24.2	Complied
125.006	Vert.	11.9	43.5	31.6	Complied
192.626	Vert.	8.2	43.5	35.3	Complied
512.000	Horiz.	33.4	46.0	12.6	Complied
528.002	Vert.	45.2	46.0	0.7	Complied
565.873	Vert.	20.5	46.0	25.5	Complied
598.713	Horiz.	22.5	46.0	23.5	Complied
662.804	Horiz.	22.9	46.0	23.1	Complied (Note 1)

Note 1: Due to the presence of an ambient signal this emission was re-measured using a substitution method. At the emission frequency a high level signal was generated in the screened room used for the initial swept measurements. This measurement was then repeated on the open area test site. The difference in amplitude between the screened room measurement and free-field measurement was then used to correct the value obtained in the screened room for the test sample.

Test Of: Red-M (Communications) Ltd.
Smart Wireless Access Server

To: FCC Part 15 Subpart C: 2000 (Intentional Radiators)
Section 15.247
(Requested Parts Only)

Test Results For Radiated Emissions: Hopping Mode (continued)

7.7.2. Electric Field Strength Measurements (Frequency Range: 1.0 to 26.0 GHz)

7.7.2.1. The following table indicates measured results with the EUT operated in Hopping mode.

7.7.2.2. Plots of all the initial scans can be found in Appendix 4.

Highest Average Level:

Frequency (GHz)	Antenna Polarity (H/V)	Average Detector level (dBmV)	Antenna factor (dB)	Cable loss (dB)	Actual Average Level (dBmV/m)	Average Limit (dBmV/m)	Average Margin (dB)	Result
1022.971	Horiz.	15.5	21.5	0.9	37.9	54.0	16.1	Complied
1055.720	Vert.	15.6	21.5	0.9	38.0	54.0	16.0	Complied
1088.701	Vert.	15.9	21.5	0.9	38.3	54.0	15.7	Complied
2298.140	Vert.	19.3	20.0	1.9	41.2	54.0	12.8	Complied
2495.895	Vert.	21.6	20.0	1.9	43.5	54.0	10.5	Complied
2506.895	Vert.	21.2	20.0	1.9	43.1	54.0	10.9	Complied

Highest Peak Level:

Frequency (GHz)	Antenna Polarity (H/V)	Peak Detector level (dBmV)	Antenna factor (dB)	Cable loss (dB)	Actual Peak Level (dBmV/m)	Peak Limit (dBmV/m)	Peak Margin (dB)	Result
1022.971	Horiz.	20.4	21.5	0.9	49.3	74.0	24.7	Complied
1055.720	Vert.	20.4	21.5	0.9	49.3	74.0	24.7	Complied
1088.701	Vert.	35.9	21.5	0.9	58.3	74.0	15.7	Complied
2298.140	Vert.	30.9	20.0	1.9	52.8	74.0	21.2	Complied
2495.895	Vert.	30.8	20.0	1.9	52.7	74.0	21.3	Complied
2506.895	Vert.	30.3	20.0	1.9	52.2	74.0	21.8	Complied

Test Of: Red-M (Communications) Ltd.
Smart Wireless Access Server
To: FCC Part 15 Subpart C: 2000 (Intentional Radiators)
Section 15.247
(Requested Parts Only)

8. Measurement Uncertainty

8.1. No measurement or test can ever be perfect and the imperfections give rise to error of measurement in the results. Consequently, the result of a measurement is only an approximation to the value of the measurand (the specific quantity subject to measurement) and is only complete when accompanied by a statement of the uncertainty of the approximation.

8.2. The expression of uncertainty of a measurement result allows realistic comparison of results with reference values and limits given in specifications and standards.

8.3. The uncertainty of the result may need to be taken into account when interpreting the measurement results.

8.4. The reported expanded uncertainties below are based on a standard uncertainty multiplied by an appropriate coverage factor, such that a confidence level of approximately 95% is maintained. For the purposes of this document “approximately” is interpreted as meaning “effectively” or “for most practical purposes”.

Measurement Type	Range	Confidence Level (%)	Calculated Uncertainty
Radiated Emissions at 3.0 metres	30 MHz to 1000 MHz	95%	+/- 5.26 dB
Radiated Emissions at 3.0 metres	1 GHz to 26 GHz	95%	+/- 4.18 dB

8.5. The methods used to calculate the above uncertainties are in line with those recommended within the various measurement specifications. Where measurement specifications do not include guidelines for the evaluation of measurement uncertainty, the published guidance of the appropriate accreditation body is followed.

Test Of: Red-M (Communications) Ltd.
Smart Wireless Access Server

To: FCC Part 15 Subpart C: 2000 (Intentional Radiators)
Section 15.247
(Requested Parts Only)

Appendix 1. Test Equipment Used

Instrument	Manufacturer	Model	RFI No.
Horn Antenna	Eaton	9188-2	A027
2 to 4 GHz Eaton Horn Antenna	Eaton	91889-2	A031
ESH3-Z5	Rohde & Schwarz	ESH3-Z5	A1069
WG 20 Horn Antenna	Flann Microwave Ltd	20240-20	A201
20 dB Attenuator	Schaffner	6820-17-B	A243
WG 12 Microwave Horn	Flann Microwave	12240-20	A253
WG 14 Microwave Horn	Flann Microwave	14240-20	A254
WG 16 Microwave Horn	Flann Microwave	16240-20	A255
WG 18 Microwave Horn	Flann Microwave	18240-20	A256
Bilog Antenna	Chase	CBL6111	A259
SMHU Signal Generator	Rohde & Schwarz	SMHU	G013
Spectrum Monitor	Rohde & Schwarz	EZM	M003
ESMI Spectrum Analyser / Receiver	Rohde & Schwarz	ESMI	M069
Fluke 77 DVM	Fluke	77	M105
Spectrum Analyser	Rohde & Schwarz	FSEB 30	M127
Thermometer/Barometer/Hydrometer	Oregan Scientific	BA-116	M170
Thermal Power Sensor	Rohde & Schwarz	NRV-Z52	M198
Power Meter	Rohde & Schwarz	NRVS	M199
Power Control	Zen	E08	S003
Site 1	RFI	1	S201
Site 15	RFI	15	S215

NB In accordance with UKAS requirements, all the measurement equipment is on a calibration schedule.

**Test Of: Red-M (Communications) Ltd.
Smart Wireless Access Server**
**To: FCC Part 15 Subpart C: 2000 (Intentional Radiators)
Section 15.247
(Requested Parts Only)**

Appendix 2. Measurement Methods

Radiated Field Strength Emissions

Radiated emissions measurements were performed in accordance with the standard, against appropriate limits for each detector function.

Initial measurements covering the entire measurement band in the form of swept scans in a shielded enclosure were performed in order to identify frequencies on which the EUT was generating interference. This determined the frequencies on which the EUT should be re-measured in full on the open area test site. In order to minimise the time taken for the swept measurements, a Peak detector was used in conjunction with the appropriate detector IF measuring bandwidth (see table below). Repetitive scans were performed to allow for emissions with low repetition rates, and for the duty cycle of the EUT. The test configuration was the same for the initial scans as for the final measurements.

The initial scans were performed using an antenna height of 1.5 m and a measurement distance of 3 m, in some circumstances at high frequencies above 12 GHz, scans were performed at 30 cm's with a corrected limit line. This was necessary due to the limited dynamic range of the measuring receiver. Following the initial scans, graphs were produced giving an overview of the emissions from the EUT plotted against the appropriate specification limit. A tolerance line was set 6 dB below the specification limit and levels above the tolerance line were re-tested on the open area test site, at the appropriate distance, using a measuring receiver with a Quasi-Peak (below 1000 MHz), Average and Peak (above 1000 MHz) detector, where applicable.

For the main (final) measurements the EUT was arranged on a non-conducting table on an open area test site, as detailed in the specification.

All measurements on the open area test site were performed using broadband antennas.

On the open area test site, at each frequency where a signal was found, the levels were maximised by initially rotating the turntable through 360°. For frequencies below 1000 MHz, the antenna was varied in height between 1 m and 4 m. For frequencies above 1000 MHz, the antenna was fixed at a height of 1.5m. At this point, any signals found to be between the limit and a level 6 dB below it were further maximised by changing the configuration of the EUT, e.g. re-routing cables to peripherals and moving peripherals with respect to the EUT.

**Test Of: Red-M (Communications) Ltd.
Smart Wireless Access Server**

**To: FCC Part 15 Subpart C: 2000 (Intentional Radiators)
Section 15.247
(Requested Parts Only)**

The test equipment settings for radiated emissions measurements were as follows:

Receiver Function	Initial Scan Below 1000 MHz	Final Measurements Below 1000 MHz
Detector Type:	Peak	Quasi-Peak (CISPR)
Mode:	Max Hold	Not applicable
Bandwidth:	100 kHz	120 kHz
Amplitude Range:	100 dB	20 dB
Measurement Time:	Not applicable	> 1 s
Observation Time:	Not applicable	> 15 s
Step Size:	Continuous sweep	Not applicable
Sweep Time:	Coupled	Not applicable

Receiver Function	Initial Scan Above 1000 MHz	Final Measurements Above 1000 MHz
Detector Type:	Peak	Peak/Average
Mode:	Max Hold	Not applicable
Bandwidth:	1 MHz	1 MHz
Amplitude Range:	100 dB	20 dB (typical)
Measurement Time:	Not applicable	> 1 s
Observation Time:	Not applicable	> 15 s
Step Size:	Continuous sweep	Not applicable
Sweep Time:	Coupled	Not applicable

Test Of: Red-M (Communications) Ltd.

Smart Wireless Access Server

To: FCC Part 15 Subpart C: 2000 (Intentional Radiators)

Section 15.247

(Requested Parts Only)

Appendix 3. Test Configuration Drawings

This appendix contains the following drawings:

Drawing Reference Number	Title
DRG\43166D01\EMIRAD	Test configuration for measurement of radiated emissions
DRG\43166D01\001	Schematic diagram of the EUT, support equipment and interconnecting cables used for the test

EMC Department

Test Of: Red-M (Communications) Ltd.
Smart Wireless Access Server

To: FCC Part 15 Subpart C: 2000 (Intentional Radiators)
Section 15.247
(Requested Parts Only)

DRG\43166D01\EMIRAD

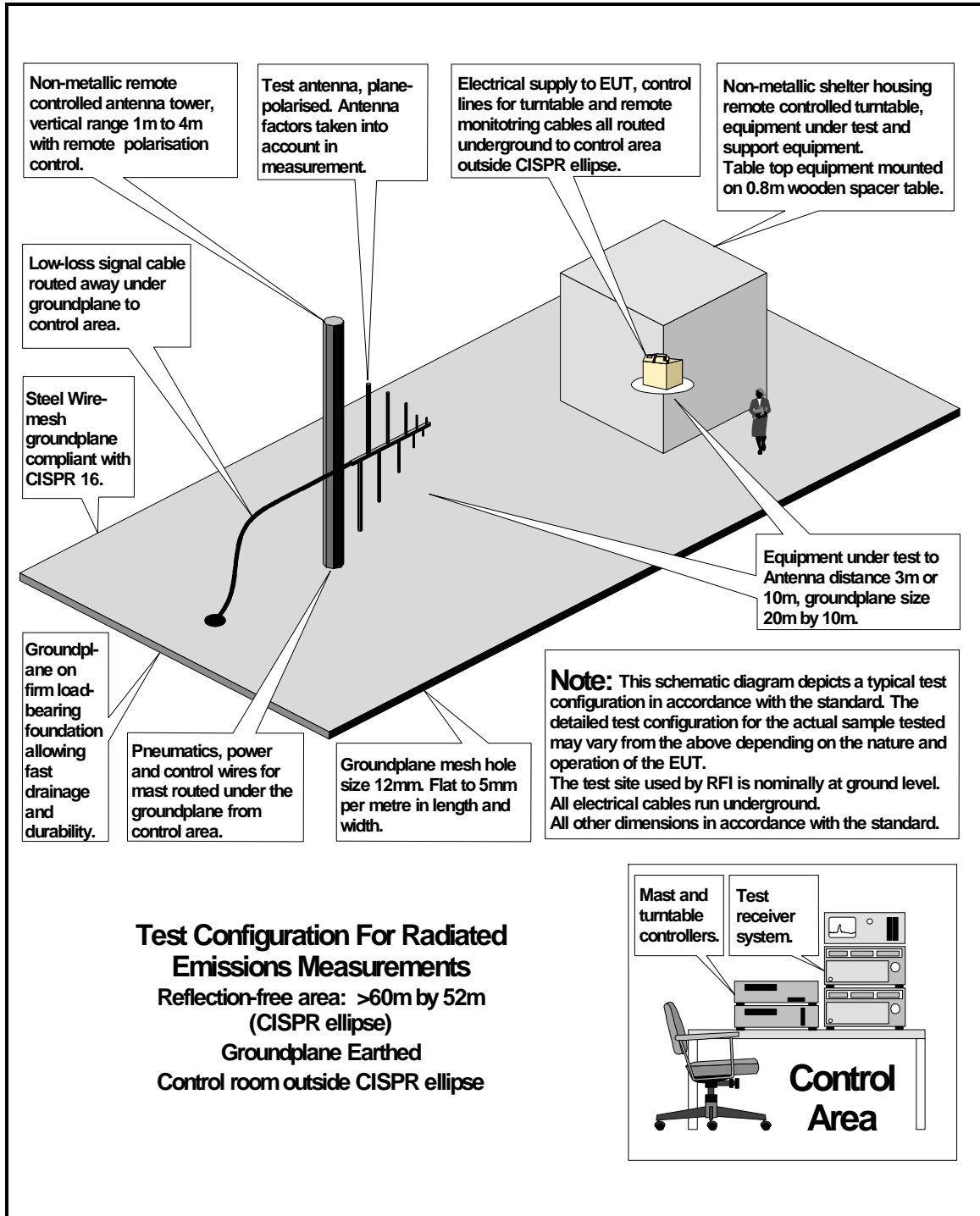

Test Of: Red-M (Communications) Ltd.
Smart Wireless Access Server

To: FCC Part 15 Subpart C: 2000 (Intentional Radiators)
Section 15.247
(Requested Parts Only)

DRG\43166D01\001

Configuration of EUT and Local Support Equipment

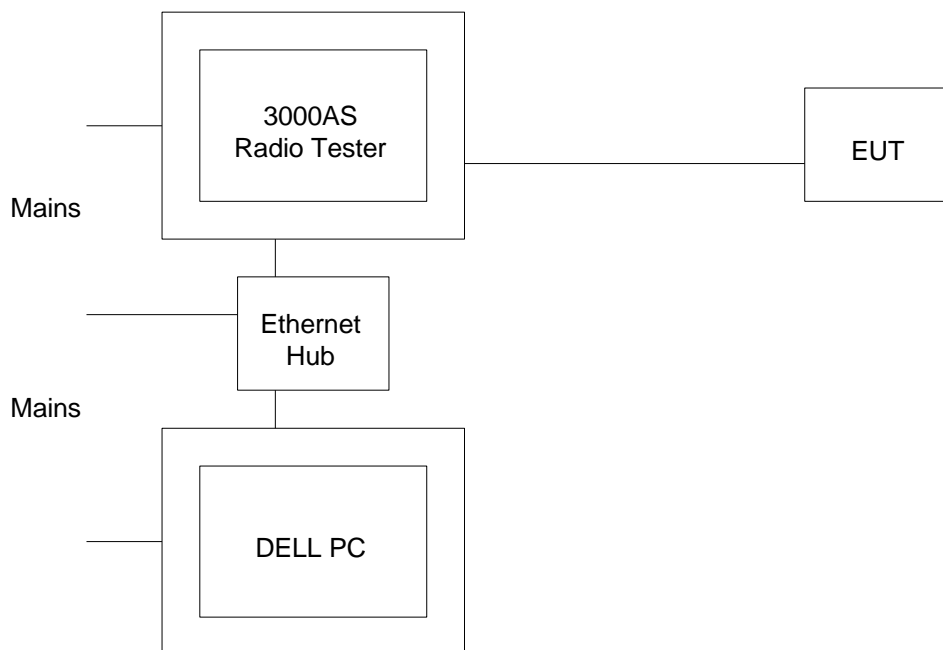

RADIO FREQUENCY INVESTIGATION LTD.

TEST REPORT

EMC Department

S.No: RFI/MPTB2/RP43166A

Page 34 of 34

Issue Date: 14 March 2002

**Test Of: Red-M (Communications) Ltd.
Smart Wireless Access Server**

**To: FCC Part 15 Subpart C: 2000 (Intentional Radiators)
Section 15.247
(Requested Parts Only)**

This page has been left intentionally blank.