

Table of Contents

Table of Contents	i
Safety Notes	1
Safety marking symbols	1
The Manual	1
FCC Conformity	2
Application Examples	2
Support	2
Abbreviations and Identifications	2
SITRANS LR250	4
Applications	5
SITRANS LR250 System Implementation	6
Programming	6
SITRANS LR250 Approvals and Certificates	6
Specifications	7
SITRANS LR250	7
Power	7
Performance.....	7
Interface	8
Mechanical.....	8
Environmental	9
Process.....	9
Approvals (verify against device nameplate).....	10
Programmer (infrared keypad)	10
Installation	11
Mounting location	12
Location on a nozzle	14
Polarization reference point	14
Mounting Instructions	15
Mounting: Threaded Version	15
Horn Location on Nozzles	16
Mounting: Stillpipe or Bypass (Sidepipe)	16
Pipe requirements.....	16
Mounting: Horn with Extension	18
SITRANS LR250 Dimensions	19
Threaded Horn Antenna.....	19
Dimensions: Horn with extensions	20
Dimensions: Flanged Horn	21
Dimensions: Flanges	22
Wiring	24
Power	24
Connecting SITRANS LR250	24
Wiring setups for hazardous area installations	25
Intrinsically Safe wiring.....	25
Non-incendive wiring (only for USA/Canada)	28
Wiring drawing (Intrinsically Safe: FM/CSA)	29

Wiring drawing (Non-incendive: FM/CSA)	30
Instructions specific to hazardous area installations	31
Quick Start	33
Activating SITRANS LR250	33
Measurement mode (RUN mode)	33
Programming SITRANS LR250	34
The handheld programmer and PROGRAM mode display	34
Quick Start Wizard via the handheld programmer	35
Level application example	37
Auto False Echo Suppression	37
Quick Start Wizard via SIMATIC PDM	38
Device Description (DD)	38
Quick Start Wizard steps.....	39
Using Linearization via the Quick Start wizard	42
Local Operation Interface	46
The LCD Display	46
Key functions in Measurement mode	47
PROGRAM mode display.....	48
Navigation view.....	48
Programming via the handheld programmer	49
Echo Profile Viewing	51
Operating SITRANS LR250 via SIMATIC PDM	52
Functions in SIMATIC PDM	52
SIMATIC PDM Rev. 6.0, SP2 Features	52
Accessing Functions	52
Online Display	53
Changing parameter settings using SIMATIC PDM	53
Configuring a new device	54
Calibrating LR 460 via PDM	54
Reset	55
Configuration Flag Reset (HART only).....	55
Auto False Echo Suppression	55
Echo profile saving.....	57
Trend Diagram (Level Trend over Time).....	57
Application Examples	58
Example 1: Liquid resin in storage vessel, level measurement	58
Example 2: Horizontal vessel with volume measurement	59
Parameter Reference	61
Pull-down menus via SIMATIC PDM	61
Quick Start Wizard	61
Appendix A: Alphabetical Parameter List	93
Appendix B: Programming Chart	95
Appendix C: Troubleshooting	97
Communication Troubleshooting	97
Generally:	97
Specifically:	97
General Fault Codes	98

Fault Codes	98
Operation Troubleshooting	101
Appendix D: Maintenance	104
Unit Repair and Excluded Liability	104
Appendix E: Technical Reference	105
Principles of Operation	105
Echo Processing	105
Measurement Response	106
Typical Receiver Signal	106
Echo Lock	107
Loss of Echo (LOE)	107
Fail-safe Mode	107
Fail-safe Timers	107
Fail-safe value	107
Far Range (Range Extension)	108
False-Echo Suppression	108
Near Range (Blanking)	108
Auto False-Echo Suppression	108
mA Output	110
Maximum Process Temperature Chart	111
Process Pressure/Temperature derating curves	
Horn Antenna or Wave Guide – ANSI Hole Pattern, 150#	113
Horn Antenna or Wave Guide DN Hole Pattern, PN16	113
Appendix F: Loop power	114
Typical Connection Drawing	114
Allowable operating area of SITRANS LR250	114
Curve 1 (General Purpose, Intrinsically Safe, Non-incendive)	114
Curve 2 (Flameproof, Increased Safety, Explosion-proof)	115
Startup Curve	115
Appendix G: Special Applications	116
Application Example: Stillpipe	116
Appendix H: HART Communications	117
SIMATIC PDM	117
HART Device Description (DD)	117
HART Communicator 375	118
Supported HART Commands:	121
Universal and Common Practice Commands	121
Device Specific Commands	121
Appendix L: Software Revision History	122
Glossary	123
Index	127
LCD menu structure	130

Safety Notes

Special attention must be paid to warnings and notes highlighted from the rest of the text by grey boxes.



WARNING: relates to a caution symbol on the product, and means that failure to observe the necessary precautions can result in death, serious injury, and/or considerable material damage.



WARNING¹: means that failure to observe the necessary precautions can result in death, serious injury, and/or considerable material damage.

Note: means important information about the product or that part of the operating manual.

Safety marking symbols

In manual	On product	Description
		Earth (ground) Terminal
		Protective Conductor Terminal
		(Label on product: yellow background.) WARNING: refer to accompanying documents (manual) for details.

The Manual

Notes:

- Please follow the installation and operating procedures for a quick, trouble-free installation and to ensure the maximum accuracy and reliability of your SITRANS LR250.
- This manual applies to the SITRANS LR250 (HART) only.

This manual will help you set up your SITRANS LR250 for optimum performance. We always welcome suggestions and comments about manual content, design, and accessibility. Please direct your comments to techpubs.smpi@siemens.com.

For other Siemens Milltronics level measurement manuals, go to: www.siemens.com/level and look under **Level Measurement**.

¹ This symbol is used when there is no corresponding caution symbol on the product.

FCC Conformity

US Installations only: Federal Communications Commission (FCC) rules

! WARNING: Changes or modifications not expressly approved by Siemens Milltronics could void the user's authority to operate the equipment.

Notes:

- This equipment has been tested and found to comply with the limits for a Class A digital device, pursuant to Part 15 of the FCC Rules. These limits are designed to provide reasonable protection against harmful interference when the equipment is operated in a commercial environment.
- This equipment generates, uses, and can radiate radio frequency energy and, if not installed and used in accordance with the instruction manual, may cause harmful interference to radio communications. Operation of this equipment in a residential area is likely to cause harmful interference to radio communications, in which case the user will be required to correct the interference at his own expense.

Application Examples

The application examples used in this manual illustrate typical installations using SITRANS LR250. Because there is often a range of ways to approach an application, other configurations may also apply.

In all examples, substitute your own application details. If the examples do not apply to your application, check the applicable parameter reference for the available options.

Standard applications are found in the main body of the manual: for more specialized applications, please see *Appendix G: Special Applications*, page 116.

Support

If you have questions you can access our 24-hour hotline at:
www.siemens.com/automation/support-request

Phone: +49 180 50 50 222.

Abbreviations and Identifications

Short form	Long Form	Description	Units
A/D	Analog to digital		
CE / FM / CSA	Conformité Européene / Factory Mutual / Canadian Standards Association	safety approval	

Short form	Long Form	Description	Units
C _i	Internal capacitance		
D/A	Digital to analog		
DAC	Digital Analog Converter		
DCS	Distributed Control System	control room apparatus	
FV	Full Vacuum		
ESD	Electrostatic Discharge		
HART	Highway Addressable Remote Transducer		
I _i	Input current		mA
I _o	Output current		mA
IS	Intrinsically Safe	safety approval	
L _i	Internal inductance		mH
LRV	Lower Range Value	value for process empty level	4 mA ¹
LSL	Lower Sensor Limit	below which no PV is anticipated	
mH	milliHenry	10 ⁻³	Henry
μF	microFarad	10 ⁻⁶	Farad
μs	microsecond	10 ⁻⁶	Second
PED	Pressure Equipment Directive	safety approval	
pF	pico Farads	10 ⁻¹²	Farad
ppm	parts per million		
PV	Primary Variable	measured value	
SV	Secondary Variable	equivalent value	
TVT	Time Varying Threshold	sensitivity threshold	
U _i	Input voltage		V
U _o	Output voltage		V
URV	Upper Range Value	value for process full level	20 mA ¹
USL	Upper Sensor Limit	above which no PV is anticipated	

1. 100% is most commonly set to 20 mA, and 0% to 4 mA: however, the settings can be reversed.

SITRANS LR250

SITRANS LR250 is a 2-wire loop-powered, continuous level measuring instrument that utilizes advanced pulse radar technology at 25 GHz. The instrument consists of an electronic component coupled to the antenna and process connection. It is very easy to install and set up, using either the infrared hand-held programmer locally, or using SIMATIC PDM from a remote location.

Communication is via HART¹. Signals are processed using Process Intelligence which has been field-proven in over 500,000 applications worldwide (ultrasonic and radar).

SITRANS LR250 is available in numerous versions, several of which are approved for use in hazardous areas. The approval rating is shown on the device nameplate.

Application Type	LR250 Version	Approval Rating	Valid for:	Wiring
Non-hazardous	General Purpose	CSA _{US/C} , FM, CE	US/Canada, Europe	See page 29
Hazardous	Intrinsically Safe (barrier required)	ATEX II 1 G, EEx ia IIC T4 ATEX 1D, EEx tD A20 IP67 T90 °C	Europe	See page 29
		IECEx SIR 05.0031X Ex ia IIC T4 EX tD A20 IP67 T90 °C	International	
		FM/CSA: Class I, Div. 1, Groups A, B, C, D Class II, Div. 1, Groups E, F, G Class III T4	US/Canada	See page 29
	Non-incendive	FM/CSA: Class I, Div. 2, Groups A, B, C, D T5	US/Canada	See page 30

Process Connections

The device is available with threaded or flange type process connections with a horn antenna.

¹. HART[®] is a registered trademark of the HART Communication Foundation.

Applications

Notes:

- Please refer to device nameplate for approval information.
- SITRANS LR250 is to be used only in the manner outlined in this manual, otherwise protection provided by the equipment may be impaired.

SITRANS LR250 is designed to measure liquid levels in a variety of applications:

- liquid bulk storage vessels
- simple process vessels with gentle agitation
- liquids
- slurries

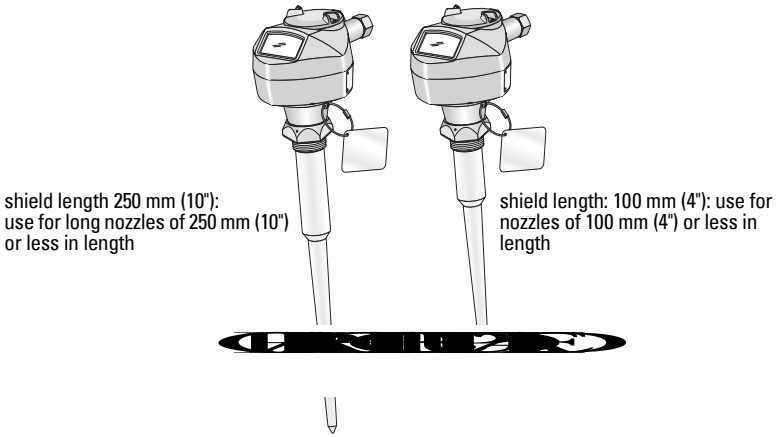

SITRANS LR250 System Implementation

SITRANS LR250 supports HART communication protocol, and SIMATIC PDM software.

Typical PLC/mA configuration with HART

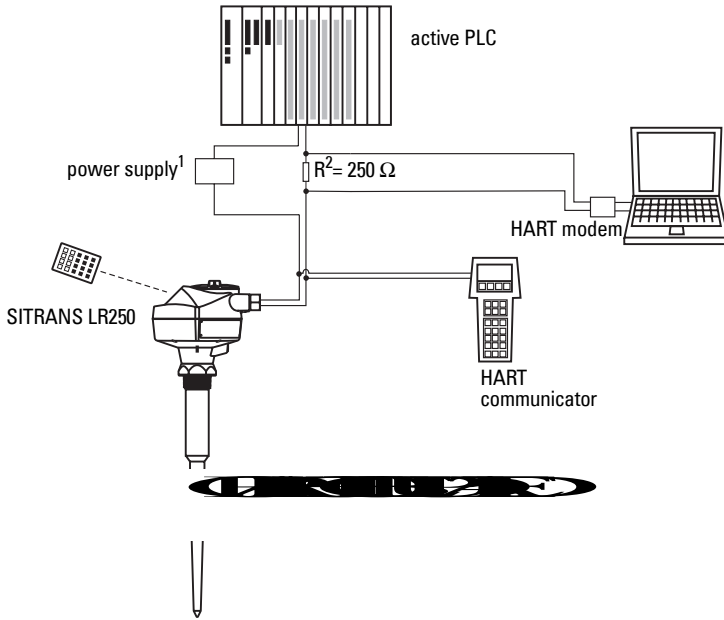

Programming

SITRANS LR250 carries out its level measurement function according to the set of built-in parameters. You can make parameter changes via the hand programmer, via a PC using SIMATIC PDM, or via a HART Handheld Communicator.

SITRANS LR250 Approvals and Certificates

Note: Please see *Approvals (verify against device nameplate)* on page 10 for an approvals listing.

1. Depending on the system design, the power supply may be separate from the PLC, or integral to it.
2. A 250 Ohm resistor may be required if the loop resistance is less than 250 Ohms.

Specifications

Note: Siemens Milltronics makes every attempt to ensure the accuracy of these specifications but reserves the right to change them at any time.

SITRANS LR250

Power



Nominal 24 V DC at
max. 550 Ohm:

For other configurations, see the chart in *Appendix J: Loop power* on page 130

- Maximum 30 V DC
- 4 to 20 mA

Performance

Reference operating conditions according to IEC 60770-1

- ambient temperature +15 to +25 °C (+59 to +77 °F)
- humidity 45% to 75% relative humidity
- ambient pressure 860 to 1060 mbar g (86000 to 106000 N/m² g)

Measurement Accuracy (measured in accordance with IEC 60770-1)

- non-linearity (accuracy) the greater of: 10 mm (0.4"), or 0.10% of High Calibration point value (including hysteresis and non-repeatability)
- non-repeatability 5 mm (included in non-linearity specification)
- deadband (resolution) 5 mm (included in non-linearity specification)

Analog Output Accuracy (measured in accordance with IEC 60770-1)

- non-linearity (accuracy) 0.125% of Span (including hysteresis and non-repeatability)
- non-repeatability 0.025% of Span (included in non-linearity specification)
- deadband (resolution) 0.0375% of Span (included in non-linearity specification)

Frequency	25.0 GHz
Measurement range ¹	0.3 to 20 m (1 to 65 ft)
Update time at 4 mA	1 second
Update time digital	≤ 1.5 seconds
Blanking distance ²	42 mm (1.65") from end of horn
Influence of ambient temperature	< 0.006% / K (average over full temperature range, referenced to maximum range)
Dielectric constant	
• 1.5" and 2" horns	$\epsilon_r > 3$
• 3" and 4" horns	$\epsilon_r > 2$
Memory:	
• non-volatile EEPROM	
• no battery required.	

Interface

- HART standard, integral to analog output
- configuration Siemens SIMATIC PDM (PC), or HART handheld communicator, or Siemens Milltronics infrared hand-held programmer
- analog output 4 to 20 mA ± 0.02 mA accuracy (for detail, see non-linearity under *Analog Output Accuracy* on page 7)
- display (local)³ dot matrix with bar graph (representing level)

Mechanical

Process Connections:

- threaded connection 1.5" or 2" NPT, BSP, or G [BS EN ISO 228-1]
- flange connection 2", 3", 4" (ANSI 150, 300#), 50, 80, 100 mm (PN16, 40, JIS 10K)
- materials 316 L stainless steel, optional Hastelloy C22

Antenna:

- horn standard 1.5" (40mm) , 2" (48 mm), 3" (75 mm), and 4" (95 mm) horn, optional 100 mm (4") horn extension
- materials 316L stainless steel with PTFE emitter
optional Hastelloy C22 with PTFE emitter

1. Minimum range is horn length + 50 mm. For the reference point for each configuration, see *SITRANS LR250 Dimensions* on page 19

2. See *Near Range (Blanking)* on page 108 for more details.

3. Display quality will be degraded in temperatures below -25 °C (-13 °F) and above +65 °C (+149 °F).

Enclosure

- construction aluminum, polyester powder-coated
- conduit entry 2 x M20x1.5, or 2 x ½" NPT
- ingress protection Type 4X/NEMA 4X, Type 6/NEMA 6, IP 67, IP68 (see note below)

Weight

- standard model < 3 kg (6.6 lb) 37.5 mm (1.5") threaded connection with horn antenna

Environmental

- location indoor/ outdoor
- altitude 5000 m (16,404 ft) max.
- ambient temperature –40 to +80 °C (–40 to +176 °F)
- relative humidity suitable for outdoor
Type 4X/NEMA 4X, Type 6/NEMA 6, IP67, IP68 enclosure (see note below)
- installation category I
- pollution degree 4

Notes:

- Please check the ambient and operating temperatures under *Enclosure* on page 9, and *Approvals (verify against device nameplate)* on page 10; also check *Approvals (verify against device nameplate)* on page 10, for the specific configuration you are about to use or install.
- Use appropriate conduit seals to maintain IP or NEMA rating.

Process

- temperature¹ –40 to 150 °C (–40 to 302 °F)
(at process connection)
- pressure (vessel)¹ Refer to *Process Pressure/Temperature derating curves* on page 107 onwards.

¹ The specifications apply to the standard horn only. The maximum temperature is dependent on the process connection, antenna materials, and vessel pressure. For more detail, or for other configurations, see *Maximum Process Temperature Chart* on page 111, and *Process Pressure/Temperature derating curves* beginning on page 112.

Approvals (verify against device nameplate)

- General CSA_{US/C}, FM, CE
- Radio Europe (R&TTE), FCC, Industry Canada
- Hazardous Intrinsically Safe (Europe) ATEX II 1G, EEx ia IIC T4
ATEX II 1D, EEx tD A20 IP67 T90 °C
(International) IECEx SIR 05.0031X, Ex ia IIC T4,
EX tD A20 IP67 T90 °C
(US/Canada) FM/CSA: (barrier required)¹
Class I, Div. 1, Groups A, B, C, D
Class II, Div. 1, Groups E, F, G
Class III T4
Non-incendive (US/Canada) FM/CSA² Class I, Div. 2,
Groups A, B, C, D T5

Programmer (infrared keypad)

Siemens Milltronics Infrared IS (Intrinsically Safe) Hand Programmer for hazardous and all other locations (battery is non-replaceable)

- approval ATEX II 1 G, EEx ia IIC T4, certificate SIRA 01ATEX2147
FM/CSA: Class I, Div. 1, Groups A, B, C, D
- ambient temperature –20 to 40 °C (–5 to 104 °F)
- interface proprietary infrared pulse signal
- power 3 V lithium battery
- weight 150 g (0.3 lb)
- color black
- Part Number 7ML5830-2AJ

¹ See *Wiring drawing (Intrinsically Safe: FM/CSA)* on page 29 for drawing number 23650653.

² See *Wiring drawing (Non-incendive: FM/CSA)* on page 30 for drawing number 23650673.

Installation



• WARNINGS:

- **Installation shall only be performed by qualified personnel and in accordance with local governing regulations.**
- **SITRANS LR250 is to be used only in the manner outlined in this manual, otherwise protection provided by the device may be impaired.**
- **Never attempt to loosen, remove, or disassemble process connection or instrument housing while vessel contents are under pressure.**
- **This product is designated as a Pressure Accessory per Directive 97/23/EC and is not intended for use as a safety device.**
- **Materials of construction are chosen based on their chemical compatibility (or inertness) for general purposes. For exposure to specific environments, check with chemical compatibility charts before installing.**
- **The user is responsible for the selection of bolting and gasket materials which will fall within the limits of the flange and its intended use and which are suitable for the service conditions.**
- **Improper installation may result in loss of process pressure.**

Notes:

- For European Union and member countries, installation must be according to ETSI EN 302372.
- Refer to the device nameplate for approval information.
- The Process Device Tag shall remain with the process pressure boundary assembly¹. In the event the instrument package is replaced, the Process Device Tag shall be transferred to the replacement unit.
- SITRANS LR250 units are hydrostatically tested, meeting or exceeding the requirements of the ASME Boiler and Pressure Vessel Code and the European Pressure Equipment Directive.
- The serial numbers stamped in each process connection body provide a unique identification number indicating date of manufacture.
Example: MMDDYY – XXX (where MM = month, DD = day, YY = year, and XXX= sequential unit produced)
Further markings (space permitting) indicate flange configuration, size, pressure class, material, and material heat code.

¹ The process pressure boundary assembly comprises the components that act as a barrier against pressure loss from the process vessel: that is, the combination of process connection body and emitter, but normally excluding the electrical enclosure.

Mounting location

Recommendations:

- Maintain ambient temperature within -40 to $+80$ °C (-40 to $+176$ °F).
- Provide easy access for viewing the display and programming via the hand programmer.
- Provide an environment suitable to the housing rating and materials of construction.
- Use a sunshield if the instrument will be exposed to direct sunlight (even though the LCD has UV protection).

Precautions:

- Avoid interference to the emission cone from obstructions or from the fill path.
- Avoid central locations on vessels.

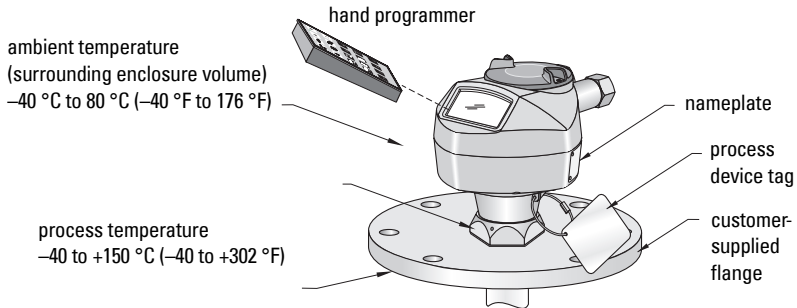

! **WARNING:** For vessels with conical or parabolic tops, avoid mounting the instrument at the centre. (The concavity of the top can focus echoes into the centre, giving false readings.)

Note: Under certain circumstances, it may be acceptable to mount SITRANS LR250 at the centre of a flat-topped tank: please discuss this with your Siemens Milltronics representative.

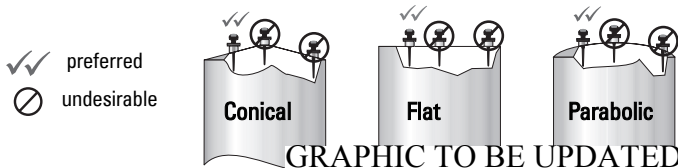

Keep the emission cone free of interference:

- Make allowance for the emission cone spreading (see table showing *beam width* on page 21).
- Locate the antenna away from the side wall, to avoid interference from indirect echoes.
- Avoid interference from objects such as ladders or pipes, which can cause false echoes.
- Make sure the emission cone does not intersect the fill path:

Notes:

- beam width (defined at -3dB boundary) depends on horn size: see table showing *beam width* on page 21
- For more detail on false echoes, see *Appendix F: Technical Reference* on page 102.

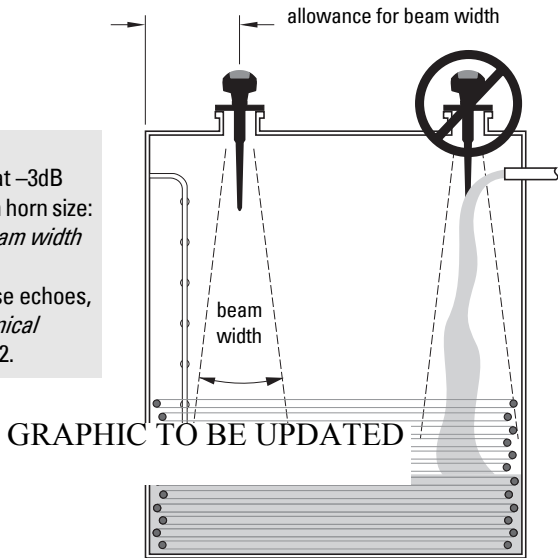

Location on a nozzle

On a nozzle, the horn should protrude a minimum of 100 mm (4") to avoid interference.

A manhole cover is typically a covered nozzle with a diameter 610 mm (24") or greater. To provide optimum signal conditions on a manhole cover, locate the horn off-center, typically 100 mm (4") from the side.

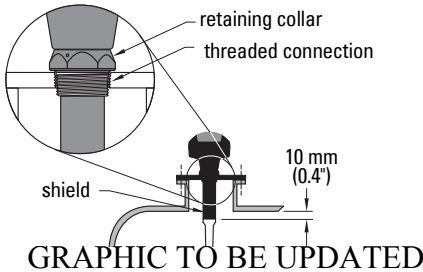

Note: For details on other applications, see *Appendix G: Special Applications* on page 109.

Polarization reference point

For best results on a tank with obstructions, or a stillpipe with openings, orient the front or back of the device toward the obstructions (see *Mounting: Stillpipe or Bypass (Sidepipe)* on page 117 for an illustration.)

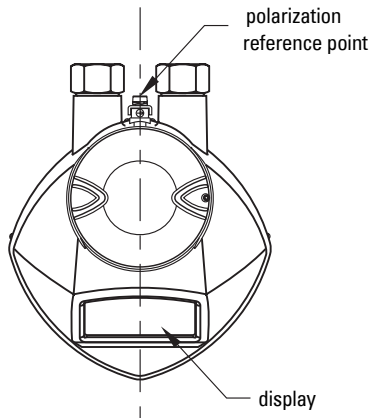

Mounting Instructions

Notes:

- The device can be rotated past 360° without damage. When mounting, rotate the head so the polarization dot faces the closest wall. In stilling well applications, line up the polarization dot with the vent hole.
- Do not rotate the enclosure after programming and vessel calibration, otherwise an error may occur, caused by a polarity shift of the transmit pulse.

Mounting: Threaded Version

1. Before inserting SITRANS LR250 into its mounting connection, check to ensure the threads are matching, to avoid damaging them.
2. Simply screw SITRANS LR250 into the process connection, and hand tighten, or use a wrench. For pressure applications, it will be necessary to use PTFE tape (or other appropriate thread sealing compound) and tighten the process connection beyond hand tight.

You can use 1.5" or 2" threaded process connections. There are three thread types: NPT, BSP, and G.

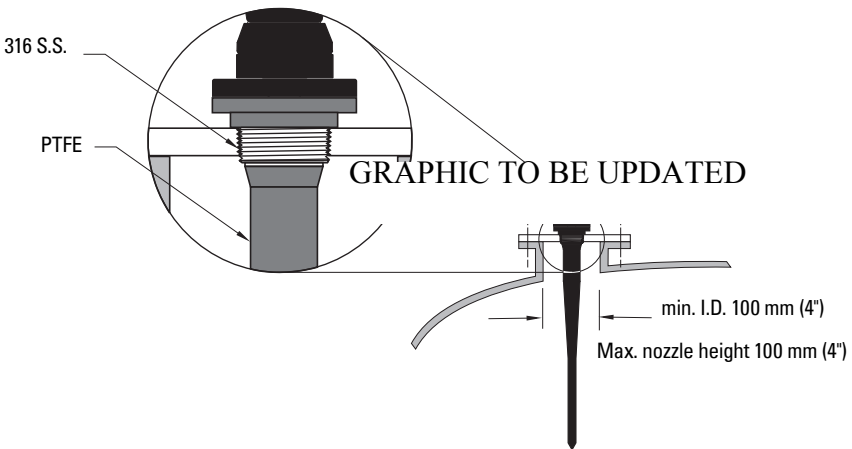

A torque of 40 N-m (30 ft.lbs) is recommended

3. If you want to rotate the enclosure, use a 2 mm Allen key to loosen the set-screws that secure the locking ring.
4. Once the enclosure is in a suitable position, tighten the set-screws. .

! **WARNING: For pressure applications, it will be necessary to use PTFE tape or other appropriate thread sealing compound, and to tighten the process connection beyond hand-tight.**

Horn Location on Nozzles

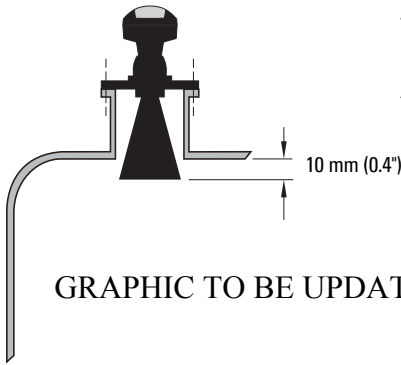

The end of the horn should protrude a minimum of 10 mm (0.4") to avoid interference with the nozzle

Mounting: Stillpipe or Bypass (Sidepipe)

This mounting arrangement is an alternative to the waveguide antenna option. It is used for products with an ϵ_r less than 3 or for extremely turbulent or vortex conditions. It can also be used to provide optimum signal conditions on foaming materials.

Pipe requirements

Diameter

Suitable pipe diameters are 50 mm (2") to 100 mm (4").

Smoothness

One continuous length of metallic pipe is preferred, without joints. If joints are unavoidable, you must machine them to close tolerances (± 0.25 mm [± 0.010 "]) and weld a connecting sleeve on the outside.

Mounting on a stillpipe

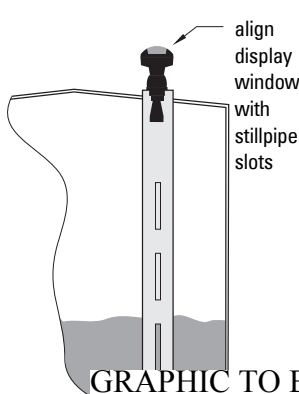

Mounting on a bypass

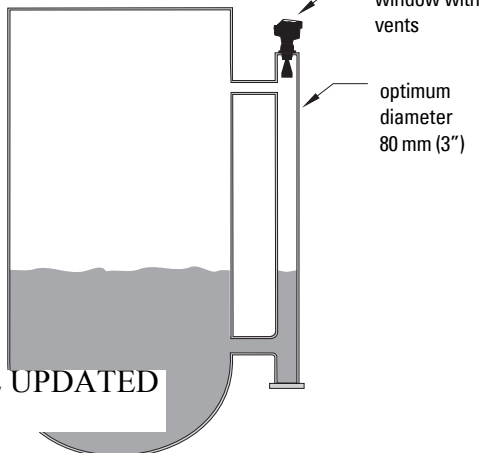

See *Propagation Factor* on page 66 for the related propagation factor.

Ensure there is a vent at the upper end of the side pipe to equalize pressure and keep the liquid-level in the pipe constant with the liquid-level in the vessel.

Mounting: Horn with Extension

Use this combination if the nozzle is long and the diameter is small.

A 100 mm (4") horn extension is available.



GRAPHIC TO BE UPDATED

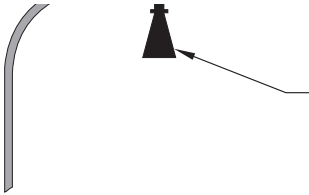

SITRANS LR250 Dimensions

Threaded Horn Antenna¹

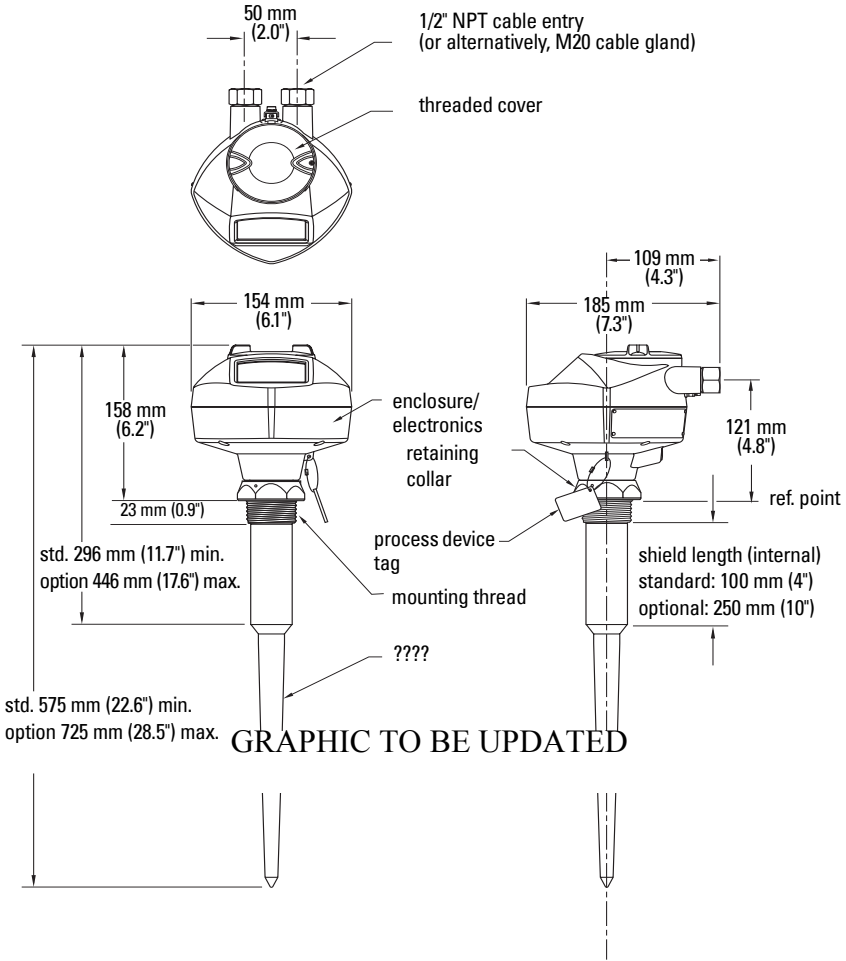

Notes:

- Process temperature and pressure capabilities are dependent upon information on the process device tag. Reference drawing listed on the tag is available on our website. Go to the product page for SITRANS LR250 at: xxxxxxx.
- Signal amplitude increases with horn diameter, so use the largest practical size.
- Optional waveguide extensions and/or purging¹ system can be installed between the flange and the antenna.

¹ An optional purging system provides an inlet on the flange where cooling air or cleaning fluid may be supplied. The air or liquid passes through the flange and exits the inside of the horn to clean the antenna system.

Dimensions: Horn with extensions

Dimensions: Flanged Horn

GRAPHIC TO BE UPDATED

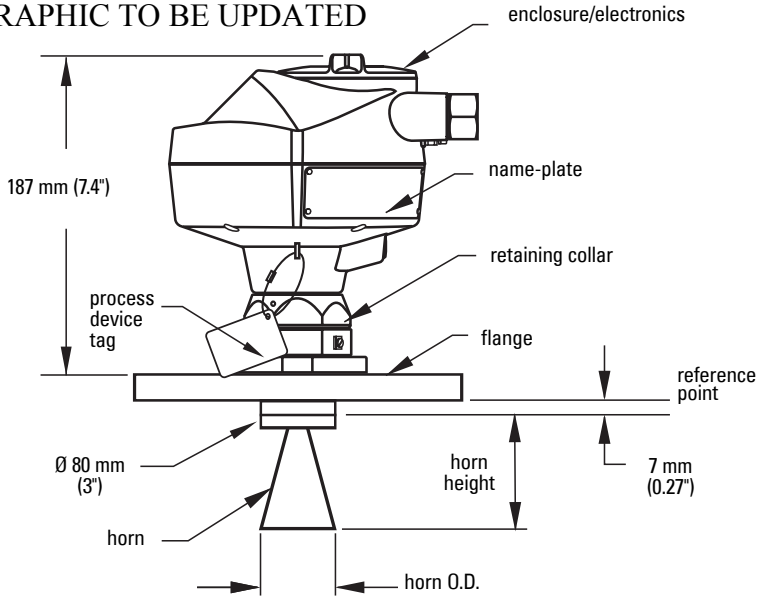

Nominal Horn Size	Horn O.D.	Horn Height	beam width ¹
37.5 mm (1.5")	40.0 mm (1.57")	100 mm (3.93")	19 degrees
50 mm (2")	47.8 mm (1.88")	96 mm (3.78")	15 degrees
80 mm (3")	74.8 mm (2.94")	164 mm (6.46")	10 degrees
100 mm (4")	94.8 mm (3.73")	214 mm (8.43")	8 degrees

1. -3dB in E-plane.

Notes:

- Process temperature and pressure capabilities are dependent upon information on the process device tag. Reference drawing listed on the tag is available on our website at www.siemens.com/processautomation, on the product page for SITRANS LR250, under Process Connection Specifications.
- Signal amplitude increases with horn diameter, so use the largest practical size.
- Optional extensions can be installed between the flange and the antenna.

Dimensions: Flanges

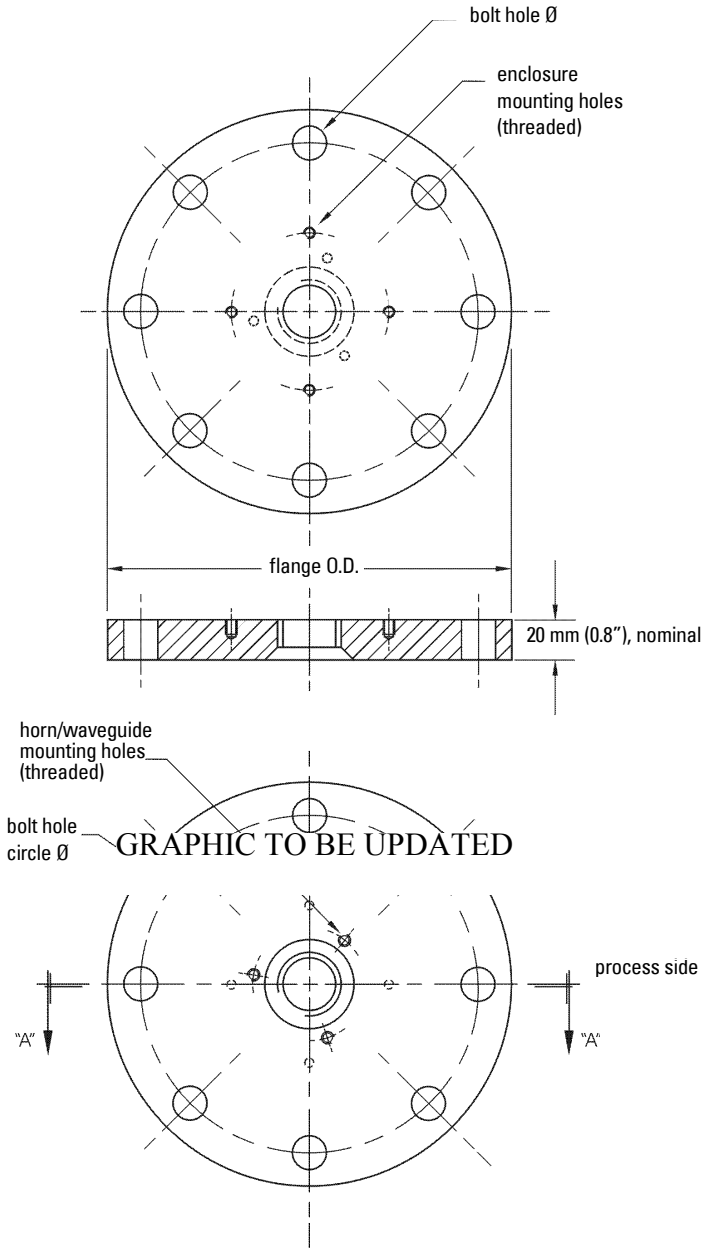

See chart on page 23 for further details on flange sizes.

Installation

Pipe size	Flange Size	Flange O.D.	Bolt Hole Circle Ø	Bolt Hole Ø	Number of Bolts
2"	ANSI 150#	6.0"	4.75"	0.7"	4
3"	ANSI 150#	7.5"	6.0"	0.75"	4
4"	ANSI 150#	9.0"	7.50"	0.75"	8
2"	ANSI 300#**	6.50"	5.00"	0.75"	4
3"	ANSI 300#	8.25"	6.62"	0.88"	8
4"	ANSI 300#	10.00"	7.88"	0.88"	8
50 mm	DIN PN 16	165 mm	125 mm	18 mm	4
80 mm	DIN PN 16	200 mm	160 mm	18 mm	8
100 mm	DIN PN 16	220 mm	180 mm	18 mm	8
50 mm	DIN PN 40	165 mm	125 mm	18 mm	4
80 mm	DIN PN 40	200 mm	160 mm	18 mm	8
100 mm	DIN PN 40	235 mm	190 mm	22 mm	8
50 mm	JIS 10K	155 mm	120 mm	19 mm	4
80 mm	JIS 10K	185 mm	150 mm	19 mm	8
100 mm	JIS 10K	210 mm	175 mm	19 mm	8

Wiring

Power

WARNINGS:



The DC input terminals shall be supplied from a source providing electrical isolation between the input and output, in order to meet the applicable safety requirements of IEC 61010-1.



All field wiring must have insulation suitable for rated voltages.

Connecting SITRANS LR250



WARNINGS:

- Check the nameplate on your instrument, to verify the approval rating.
- Use appropriate conduit seals to maintain IP or NEMA rating.
- Read *Instructions specific to hazardous area installations* on page 31.

Notes:

- Use twisted pair cable: AWG 22 to 14 (0.34 mm² to 2.5 mm²).
- Separate cables and conduits may be required to conform to standard instrumentation wiring practices or electrical codes.

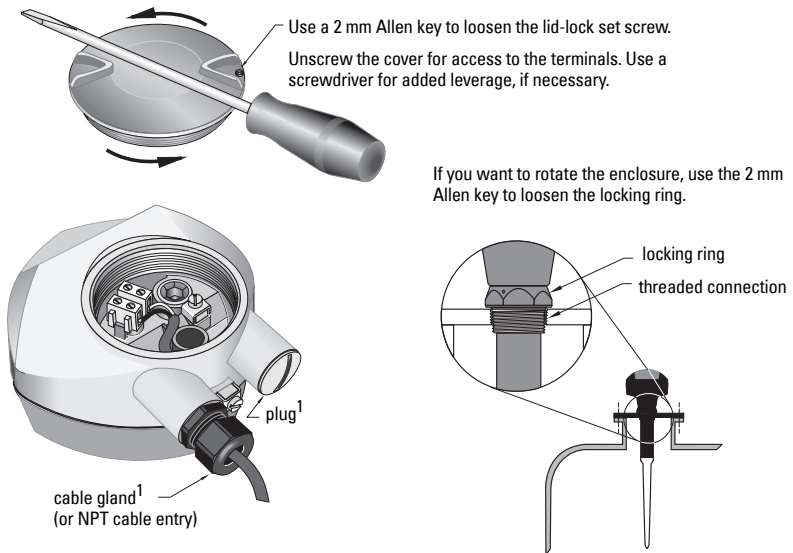

¹ Depending on the approval rating, glands and plugs may be supplied with your instrument.

- Strip the cable jacket for approximately 70 mm (2.75") from the end of the cable, and thread the wires through the gland¹.
- Connect the wires to the terminals as shown: the polarity is identified on the terminal block.
- Ground the instrument according to local regulations.
- Tighten the gland to form a good seal.

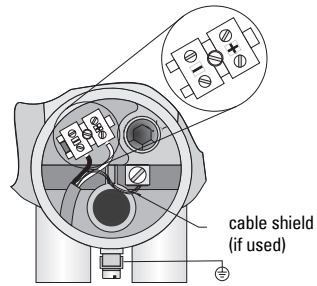

Wiring setups for hazardous area installations

There are five wiring options for hazardous area installations. In all cases, check the nameplate on your instrument, and confirm the approval rating.

1. Intrinsically Safe wiring

<p>SIEMENS</p> <p>SITRANS LR 250 7ML1234-56789-0ABC-D Serial No: GYZ / S1034567 Encl.: NEMA / TYPE 4X, 6, IP67, IP68 Amb.Temp.: - 40 °C to 80 °C Power Rating: 24V --- Nom., 30 V --- Max., 4 - 20mA</p> <p>Siemens Milltronics Process Instruments Inc., Peterborough Made in Canada</p>	<p>li = 120 mA Ui = 30V Li = 0.1mH Pi = 0.8W Ci = 15nF HART</p> <p>Ex SIRA</p> <p>II 1 D IP68 Txx II 1 G EEx ia IIC T4 03ATEX2142X IECEX SIR 05.0031X Ex ia IIC T4</p> <p>CE 0682 0518</p> <p>WARNING: Possible Static Hazard, Do Not Rub Or Clean On Site.</p>
<p>SIEMENS</p> <p>SITRANS LR 250 7ML1234-56789-0ABC-D Serial No: GYZ / S1034567 Encl.: NEMA / TYPE 4X, 6, IP67, IP68 Amb.Temp.: - 40 °C to 80 °C Power Rating: 24V --- Nom., 30 V --- Max., 4 - 20mA</p> <p>Siemens Milltronics Process Instruments Inc., Peterborough Made in Canada</p>	<p>CANADA: 2677 - LR 250 Exia per drawing: 23650653 Class I, Div1, Group A, B, C, D Class II, Div1, Group G Class III HART</p> <p>FCC ID: NJA - LR 250 Temp. Code : T4 I max = 120mA P max = 0.8 W V max = 30V C i = 15 nF L i = 0.1 mH</p> <p>FM APPROVED 159134</p> <p>WARNING: Possible Static Hazard, Do Not Rub Or Clean On Site.</p>

Approval Rating	Valid for:
ATEX II 1 G, EEx ia IIC T4 ATEX II 1 D, EEx tD A20 IP67 T90 °C	Europe
IECEX SIR 05.0031X, Ex ia IIC T4, Ex tD A20 IP67 T90 °C	International
FM/CSA: Class I, Div. 1, Groups A, B, C, D Class II, Div. 1, Groups E, F, G Class III	US/Canada

- If cable is routed through conduit, use only approved suitable-size hubs for waterproof applications.

- For power demands see *Curve 1 (General Purpose, Intrinsically Safe, Non-incendive)* on page 111.
- For wiring requirements:
 Europe/International: Follow local regulations.
 US/Canada: Download *Wiring drawing (Intrinsically Safe: FM/CSA)* drawing number 23650563 from the product page of our website at: ##### or see page 29.
- Approved dust-tight and water-tight conduit seals are required for outdoor NEMA 4X / type 4X / NEMA 6, IP67, IP68 locations.
- Recommended intrinsically safe barriers are listed on page 26.
- Refer to *Instructions specific to hazardous area installations* on page 31.

Note: Selecting a suitable PLC input module, power supply, or barrier requires knowledge about Intrinsic Safety and the application. It is the responsibility of the installer to ensure that the intrinsically safe installation complies with both the apparatus approval requirements and the relevant national code of practice.

Notes:

- The following list is not exhaustive: there are many IS power supplies and barriers on the market which will work with the LR 250.
- The PLC input modules and barriers listed below have all been tested and are functionally compatible with the LR 250.

PLC Input Modules

Manufacturer	Part Number
Siemens	SM331 PCS7 HART Input Module
Stahl	Type 9461 Analog Input 2-Wire HART Module (for IS1)
Siemens	4 x Analog Input I 2-Wire HART Module (for ET200iSP)
Bartec	Profibus Interface - 8 x 4...20mA Input Module
ABB	AI930N 4 x Analog Input HART Module (for S900)
Siemens	SM331 2 x Analog Input HART Module (for ET200M)
Siemens	SM331 4 x Analog Input Module (for ET200M)

Passive Shunt Diode Barriers

Note: A well regulated supply voltage is required.

Manufacturer	Part Number
MTL	787SP+ (Dual Channel)
MTL	7787P+ (Dual Channel)
Stahl	9001/01-280-100-10 (Single Channel)
Stahl	9002/01-280-110-10 (Dual Channel)

How to select a passive barrier for SITRANS LR 250



1. Make sure that the barrier safety description is suitable for the LR 250 Intrinsically Safe (IS) input parameters.
2. Determine the maximum end-to-end resistance of the barrier (R_{e-e}) from the data sheet.
3. Determine other loop resistance (R_{loop}): for example, sense resistance, displays, and/or PLC inputs.
4. Calculate $R_{working} = R_{e-e} + R_{loop}$.
5. Determine any non-linear voltage drops due to the barrier ($V_{barrier}$) from the barrier data sheet (for example, voltage drops due to diodes).
6. Calculate $V_{working} = V_{supply} - V_{barrier}$.

Using $V_{working}$ and $R_{working}$, confirm that operation is within the shaded area of the graph *Loop Voltage versus Loop Resistance* on page 111

Active barriers (repeating barriers)

Manufacturer	Part Number
MTL	706
MTL	7206
Stahl	9001/51-280-110-14
Pepperl+Fuchs	KSD2-CI-S-Ex
Pepperl+Fuchs	KFD2-STC3-Ex1
MTL	E02009 - verify
MTL	E02010

2. Non-incendive wiring (only for USA/Canada)

SIEMENS			
SITRANS LR 250 7ML1234-56789-0ABC-D Serial No: GYZ / S1034567 Encl.: NEMA / TYPE 4X, 6, IP67, IP68 Amb. Temp.: -40 °C to 80 °C Power Rating: 24V --- Nom., 30 V --- Max., 4 - 20mA Siemens Milltronics Process Instruments Inc., Peterborough Made in Canada			
		CANADA: 267P - LR 250 FCC ID: NJA - LR 250 26 Ghz HART	Class I, Div. 2, Group A, B, C, D Temp. Code: T5
		This device complies with Part 15 of the FCC Rules. Operation is subject to the following two conditions 1) This device may not cause harmful interference and 2) This device must accept any interference received, including interference that may cause undesired operation	
		  1591.34	

Approval Rating	Valid for:
FM/CSA: Class I, Div. 2, Groups A, B, C, D T5	US/Canada

- For power demands see *Curve 1 (General Purpose, Intrinsically Safe, Non-incendive)* on page 111.
- For wiring requirements download *Wiring drawing (Non-incendive: FM/CSA)* drawing number 23650637 from the product page of our website at: #####, or see page 30.

Wiring drawing (Intrinsically Safe: FM/CSA)

TO BE REPLACED WITH FLIP-OUT PAGE 23650653

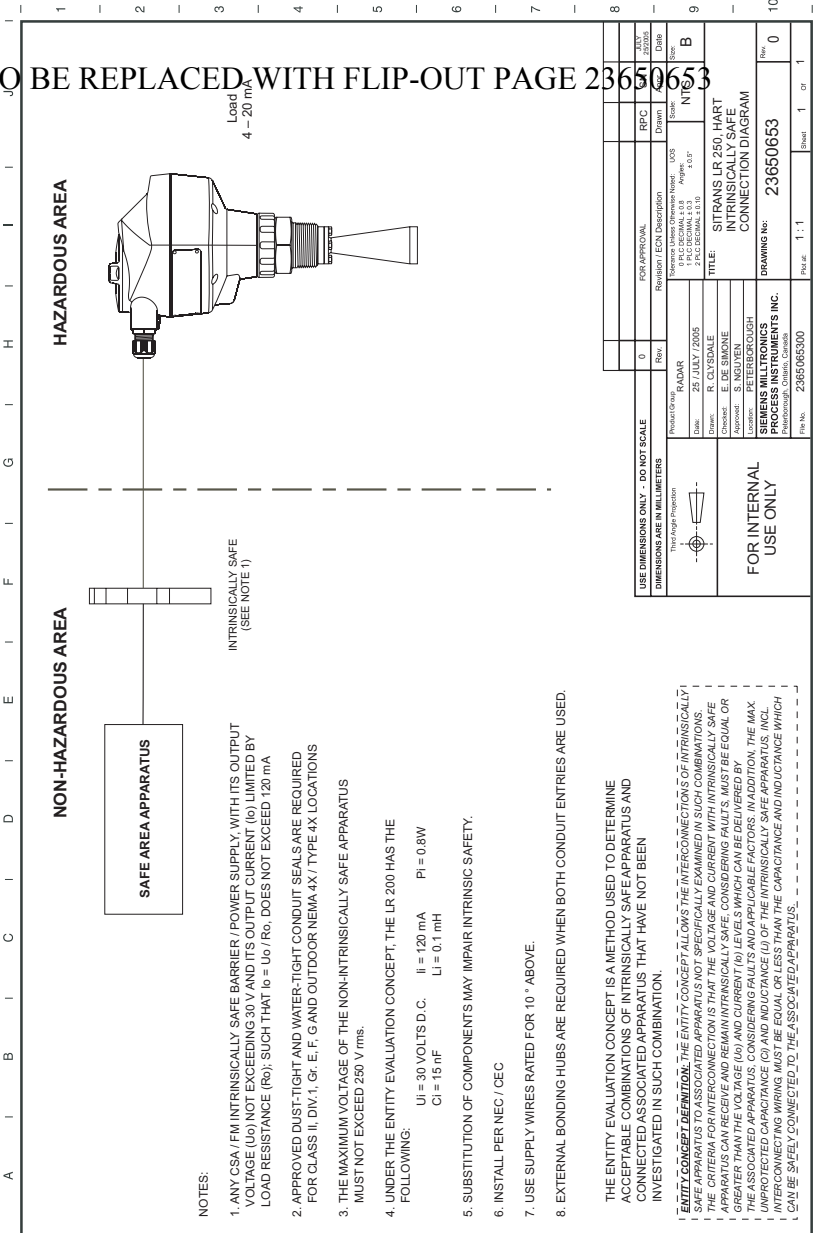

NOTES:

1. ANY CSA/FM INTRINSICALLY SAFE BARRIER / POWER SUPPLY WITH ITS OUTPUT VOLTAGE (U₀) NOT EXCEEDING 30 V AND ITS OUTPUT CURRENT (I₀) LIMITED BY LOAD RESISTANCE (R₀), SUCH THAT I₀ = U₀ / R₀, DOES NOT EXCEED 120 mA
2. APPROVED DUST-TIGHT AND WATER-TIGHT CONDUIT TYPES ARE REQUIRED FOR CLASS II, DIV. 1, Gr. E, F, G AND OUTDOOR NEIMA 4X / TYPE 4X LOCATIONS
3. THE MAXIMUM VOLTAGE OF THE NON-INTRINSICALLY SAFE APPARATUS MUST NOT EXCEED 250 V rms.
4. UNDER THE ENTITY EVALUATION CONCEPT, THE LR 200 HAS THE FOLLOWING:
 U_I = 30 VOLTS D.C. I_I = 120 mA P_I = 0.8W
 C_I = 15 nF L_I = 0.1 mH
5. SUBSTITUTION OF COMPONENTS MAY IMPAIR INTRINSIC SAFETY.
6. INSTALL PER NEC / CEC
7. USE SUPPLY WIRES RATED FOR 10 ° ABOVE.
8. EXTERNAL BONDING HUBS ARE REQUIRED WHEN BOTH CONDUIT ENTRIES ARE USED.

THE ENTITY EVALUATION CONCEPT IS A METHOD USED TO DETERMINE ACCEPTABLE COMBINATIONS OF INTRINSICALLY SAFE APPARATUS AND CONNECTED ASSOCIATED APPARATUS THAT HAVE NOT BEEN INVESTIGATED IN SUCH COMBINATION.

ENTITY EVALUATION CONCEPT: THE ENTITY EVALUATION CONCEPT IS A METHOD USED TO DETERMINE ACCEPTABLE COMBINATIONS OF INTRINSICALLY SAFE APPARATUS TO ASSOCIATED APPARATUS NOT SPECIFICALLY EXAMINED IN SUCH COMBINATIONS. THE CRITERIA FOR INTERCONNECTION IS THAT THE VOLTAGE AND CURRENT WITH INTRINSICALLY SAFE APPARATUS CAN RECEIVE AND REMAIN INTRINSICALLY SAFE, CONSIDERING FAULTS. MUST BE EQUAL OR GREATER THAN THE VOLTAGE (U₀) AND CURRENT (I₀) LEVELS WHICH CAN BE DELIVERED BY THE ASSOCIATED APPARATUS, CONSIDERING FAULTS AND APPLICABLE FACTORS. IN ADDITION, THE MAXIMUM VOLTAGE AND CURRENT OF THE ASSOCIATED APPARATUS MUST BE EQUAL OR LESS THAN THE CAPACITANCE AND INDUCTANCE WHICH CAN BE SAFELY CONNECTED TO THE ASSOCIATED APPARATUS.

USE DIMENSIONS ONLY - DO NOT SCALE		FORM APPROVAL		Revision / ECH Description	
DIMENSIONS ARE IN MILLIMETERS		0		RPC	
Third-Party Program		Product Code: RADAR		Scale:	Rev:
		Date:	25 / JULY / 2005	Scale:	N/A
		Drawn:	R. CLYSDALE	Scale:	B
		Checked:	E. DE SIMONE	TITLE: STRANS LR 250 HART INTRINSICALLY SAFE CONNECTION DIAGRAM	
		Approved:	S. NGUYEN	DRAWING No: 23650653	
FOR INTERNAL USE ONLY		SIEMENS INSTRUMENTS INC.		Rev: 0	
		Parsippany, Ontario, Canada		Part. no.: 1:1	
		File No.: 2365065300		Sheet: 1 of 1	



Wiring drawing (Non-incendive: FM/CSA)

TO BE REPLACED WITH FLIP-OUT PAGE 23650637

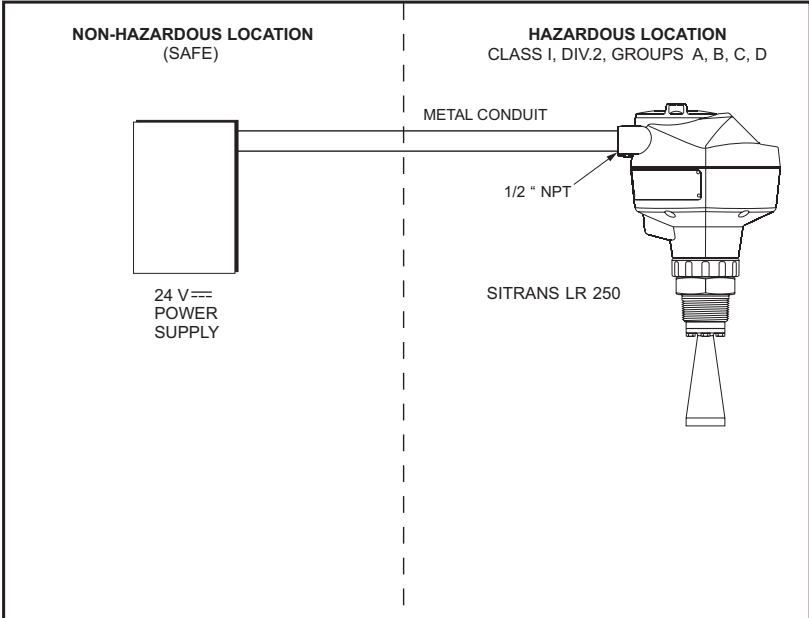

NOTES:

- 1) INSTALLATION SHALL BE DONE IN ACCORDANCE WITH THE N.E.C. AND C.E.C. PART ONE.
- 2) USE APPROVED WATER TIGHT CONDUIT FITTINGS FOR OUTDOOR APPLICATIONS.
- 3) FOR FURTHER INFORMATION REFER TO THE SITRANS LR 250 INSTRUCTION MANUAL

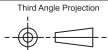
USE DIMENSIONS ONLY - DO NOT SCALE		0	FOR CONSTRUCTION		RPC	SN	JULY 25/2005
DIMENSIONS ARE IN INCHES		Rev.	Revision / ECN Description		Drawn	Appr.	Date
 <p>FOR INTERNAL USE ONLY</p>	Product Group	RADAR		Tolerance Unless Otherwise Noted: UOS	Scale:	NTS	Size: A
	Date:	20 / JULY / 2005		1 Place Decimal ± 0.03	Angles ± 0.5°		
	Drawn:	R. CLYSDALE		2 Place Decimal ± 0.01			
	Checked:	T. LITTLE		3 Place Decimal ± 0.002			
		Approved:	S. NGUYEN		TITLE: SITRANS LR 250 CLASS I, Div. 2 CONNECTION DRAWING		
		Location:	PETERBOROUGH		DRAWING No: 23650637		Rev. 0
		SIEMENS MILLTRONICS PROCESS INSTRUMENTS INC. Peterborough, Ontario, Canada					
		File No.	2365063700		Plot at: 1 : 1	Sheet 1 of 1	

Instructions specific to hazardous area installations

(Reference European ATEX Directive 94/9/EC, Annex II, 1/0/6)

The following instructions apply to equipment covered by certificate number SIRA 03ATEX2142X:

1. For use and assembly, refer to the main instructions.
2. The equipment is certified for use as Category 1GD equipment.
3. The equipment may be used with flammable gases and vapors with apparatus group IIC and temperature class T4.
4. The equipment is certified for use in an ambient temperature range of $-40\text{ }^{\circ}\text{C}$ to $80\text{ }^{\circ}\text{C}$.
5. The equipment has not been assessed as a safety related device (as referred to by Directive 94/9/EC Annex II, clause 1.5).
6. Installation and inspection of this equipment shall be carried out by suitably trained personnel in accordance with the applicable code of practice (EN 60079-14 and EN 60079-17 in Europe).
7. Repair of this equipment shall be carried out by suitably trained personnel in accordance with the applicable code of practice (e.g. EN 60079-19 within Europe).
8. Components to be incorporated into or used as replacements in the equipment shall be fitted by suitably trained personnel in accordance with the manufacturer's documentation.
9. The 'X' suffix to the certificate number relates to the following special conditions for safe use:
 - a. Parts of the enclosure may be non-conducting and may generate an ignition-capable level of electrostatic charge under certain extreme conditions. The user should ensure that the equipment is not installed in a location where it may be subjected to external influences which might cause a build-up of electrostatic charge on non-conducting surfaces.
 - b. As either Aluminum, Magnesium, Titanium or Zirconium may be used at the accessible surface of the equipment, in the event of rare incidents, ignition sources due to impact and friction sparks could occur. This shall be considered when the SITRANS LR 250 is being installed in locations that specifically require group II, category 1G equipment.

(continued on next page)

10. The certification of this equipment relies upon the following materials used in its construction:

Aluminum alloy ANSI ref. A380.0 (aluminum enclosure option)

Valox 365 (injection moulded plastic enclosure option)

Ultem 1010 (window on plastic enclosure option)

Stycast 2651-40FR encapsulant, catalyst II

The detailed composition of Aluminum A380.0 as used in the metal enclosure (threaded lid option only) is as follows:

Si – 8.5%, Fe – 1.3%, Cu – 3.5%, Mn – 0.5%, Mg – 0.1%, Ni – 0.1%, Zn – 3%, Sn – 0.35%, others – 0.5%, Al - balance

In applications requiring category 1G or 1/2G equipment, SITRANS LR250 must not be exposed to materials to which the wetted parts¹ of the instrument are not resistant.

11. Equipment Marking

The equipment marking contains at least the information on the product nameplate.

LR 250 Version	Approval Rating	Nameplate
Intrinsically Safe	ATEX II 1 G, EEx ia IIC T4 ATEX II 1 D, EEx tD A20 IP67 T90 °C	
	IECEx SIR 05.0031X, Ex ia IIC, Ex tD A20 IP67 T90 °C T4	
	FM/CSA: Class I, Div. 1, Groups A, B, C, D Class II, Div. 1, Groups E, F, G Class III T4	See page 25
Non-incendive	FM/CSA: Class I, Div. 2, Groups A, B, C, D T5	See page 28

¹ Any surface (probe, o-rings, gaskets) exposed to the process fluid or gas.

Quick Start

Note: SITRANS LR250 supports SIMATIC PDM version 6.0 with SP2.

A Quick Start wizard groups together all the settings you need for a simple application. There are two ways to access the wizard:

- *Quick Start Wizard via the handheld programmer* on page 35
- *Quick Start Wizard via SIMATIC PDM* on page 38

Activating SITRANS LR250

Note: Keep infrared devices such as laptops, cell phones, and PDAs, away from SITRANS LR250 to prevent inadvertent operation.

Power up the instrument. SITRANS LR250 automatically starts up in Measurement (RUN) mode.

Measurement mode (RUN mode)

Normal operation

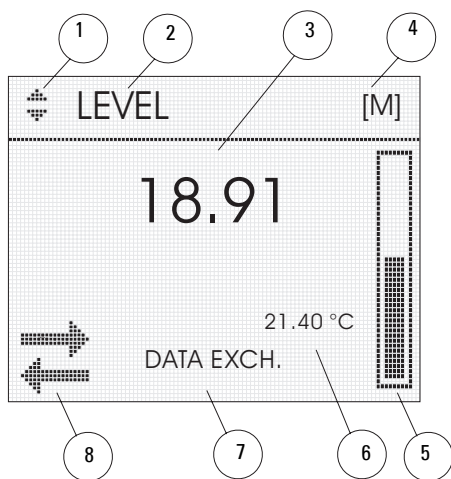

- 1 – toggle indicator for linear units or %
- 2 – selected operation: level, space, or distance
- 3 – measured value (level, space or distance)
- 4 – units
- 5 – bar graph indicates level
- 6 – secondary region indicates electronics temperature, echo confidence, loop current, or distance¹
- 7 – text area displays status messages
- 8 – device status indicator

Fault present



S: 0 LOE



S: 53 CONFIG LO

If more than one fault is present, the status indicator and text for each fault alternate at 2 second intervals. See *General Fault Codes* on page 79 for a list.

¹ In response to a key press request. For details, see *Navigating in PROGRAM mode* on page 73.

Programming SITRANS LR250

- For detailed information see *Appendix F: Local Operation Interface* on page 94. or *Parameter Reference* on page 41.
- To program SITRANS LR250 using the Quick Start wizard, follow the instructions below.







The handheld programmer and PROGRAM mode display

Notes:



- See *Appendix F: Local Operation Interface* on page 94 for more detailed information on the programmer and the LCD display.
- SITRANS LR250 automatically returns to Measurement mode after a period of inactivity in PROGRAM mode (between 15 seconds and two minutes, depending on the menu level).

- Point the programmer at the display (from a maximum distance of 600 mm [2 ft.]), then press **Right ARROW**  to activate PROGRAM mode and open menu level 1.

(**Mode**  opens the menu level last displayed in PROGRAM mode within the last 10 minutes, unless power has been cycled since then. Then menu level 1 will be displayed.)

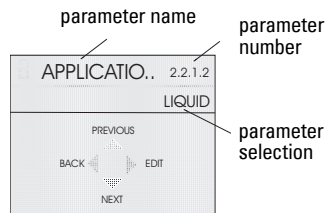
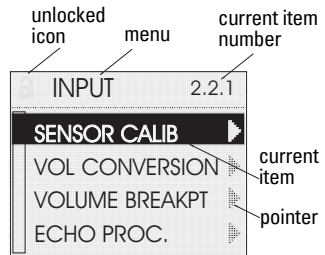
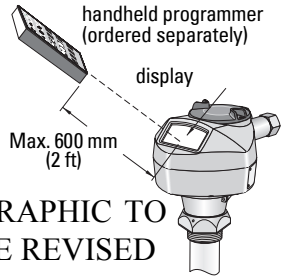
- Use **ARROW keys** to navigate to a menu item. The current selection is highlighted and the level number is shown. A pointer is visible if a lower level exists.
- Press **Down** or **Up ARROWS**   to scroll to the next selection.
- At higher menu levels press **Right ARROW**  to open the next menu level or **Left ARROW**  to back up one level.
- At the lowest menu level, parameters are listed, and no pointers are visible. Press **Right ARROW**  to open parameter view.
- In parameter view, the parameter name and number are displayed, as well as current selection or value. Press **Right ARROW**  to open **Edit** mode.



- The current selection is highlighted.
If required, scroll to a new selection or key in a new value and press **Right ARROW**  to accept it. The LCD displays the new value.
- Press **Mode**  to return to Measurement mode.

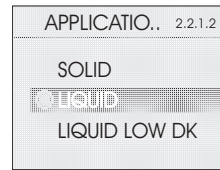







Quick Start Wizard via the handheld programmer

Notes:

- The wizard is a complete package and the settings are inter-related.
- Because the settings are inter-related, the initial Quick Start parameter values are not default values and do not necessarily reflect the current device configuration.
- Do not use the Quick Start wizard to modify individual parameters: see instead *Parameter Reference* on page 41.

1. Quick Start

- Point the programmer at the display (from a maximum distance of 600 mm [2 ft.]), then press **Right ARROW**  to activate PROGRAM mode and open menu level 1.
- Press **Right ARROW**  twice to navigate to menu item 1.1 and open parameter view.
- Press **Right ARROW**  to open **Edit** mode or **Down ARROW**  to accept default values and move directly to the next item.
- To change a setting, scroll to the desired item or key in a new value.
- After modifying a value, press **Right ARROW**  to accept it and press **Down ARROW**  to move to the next item.
- Quick Start settings take effect only after you select **Yes** to **Apply changes** in step 1.7.

1.1. Application Type

Options	LIQUID
	SOLID
	LIQUID LOW DK (low dielectric liquid)

1.2. Response Rate

Sets the reaction speed of the device to measurement changes in the target range.

Options	SLOW	0.1 m/minute
	MED	1.0 m/minute
	FAST	10.0m/minute

Use a setting just faster than the maximum filling or emptying rate (whichever is greater). Slower settings provide higher accuracy; faster settings allow for more level fluctuation

1.3. Sensor Units

Select the units for the Quick Start variables (high and low calibration point, and level, distance, or space)

Options	M, CM, MM, FT, IN
----------------	-------------------

1.4. Operation

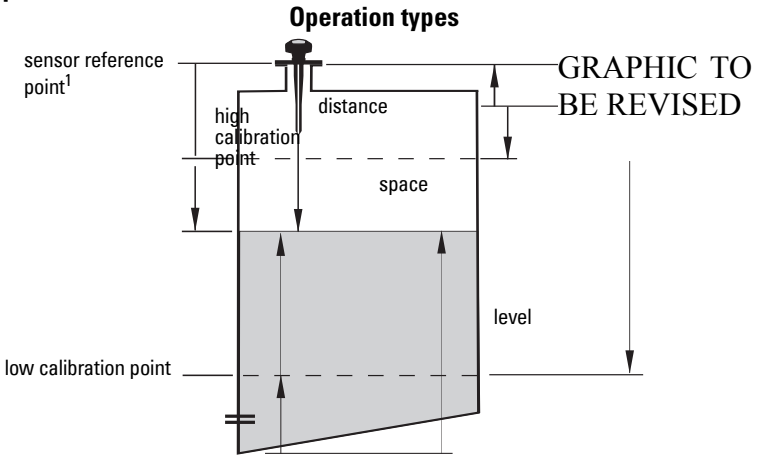

Options	NO SERVICE	
	LEVEL	Distance to material surface referenced from Low Calibration Point (process empty level).
	SPACE	Distance to material surface referenced from High Calibration Point (process full level).
	DISTANCE	Distance to material surface referenced from Sensor Reference Point.

1.5. Low Calibration Point

Distance from Sensor Reference to Low Calibration Point: usually process empty level. (See 1.4. Operation for an illustration.)

Values	Range: 0.0000 to 20.000 m
---------------	---------------------------

1.6. High Calibration Point

Distance from Sensor Reference to High Calibration Point: usually process full level. (See 1.4. Operation for an illustration.)

Values	Range	0.0000 to 20.000 m
---------------	-------	--------------------

1.7. Apply? (Apply changes)

In order to save the Quick Start settings it is necessary to select Yes to apply changes.

Options	YES, NO
----------------	---------

Press **Mode**  to return to Measurement mode. SITRANS LR250 is now ready to operate.

¹ The point to which all of the above parameters are referenced. See *SITRANS LR 250 Dimensions* on page 14.

Level application example

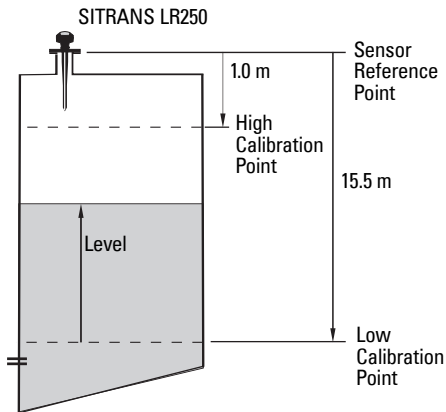

The application is a vessel that takes an average 3 hours to fill and 3 weeks to empty.

Fill rate = 0.09 m/minute (15.5 / 180).
Response rate has been set to **slow**: 0.1 m/minute, or slightly faster than the fill rate

GRAPHIC TO BE REVISED

Quick Start Setting		Description
APPLICATION	LIQUID	
RESPONSE RATE	SLOW	Response rate = 0.1 m/minute.
UNITS	m	
OPERATION	LEVEL	Material level referenced from Low Calibration Point.
LOW CALIBRATION POINT	15.5	Process empty level.
HIGH CALIBRATION POINT	1.0	Process full level.
APPLY? (CHANGES)	YES	Save new settings.

Auto False Echo Suppression

If SITRANS LR250 displays a false high level, or the reading is fluctuating between the correct level and a false high level, you can use the Auto False Echo Suppression parameters to prevent false echo detection. See *2.2.5. TVT (Auto False Echo Suppression) setup* on page 41 for instructions.

Quick Start Wizard via SIMATIC PDM

The graphical Quick Start Wizard groups together all the settings you need to make for a simple application into 4 steps.

To use HART or PROFIBUS PA, you will need a PC configuration tool: we recommend SIMATIC PDM.







Please consult the operating instructions or online help for details on using SIMATIC PDM. (Application Guides for setting up Siemens HART and PROFIBUS PA instruments with SIMATIC PDM are available on our website: www.siemens.com/processautomation.)

Device Description (DD)

You will need the DD for SIMATIC PDM version 6.0 with SP2. You can locate the DD in Device Catalog, under **Sensors/Level/Echo/Siemens Milltronics/SITRANS LR250**. If you do not see **SITRANS LR250** under Siemens Milltronics, you can download the DD from the product page of our website at: <https://pia.khe.siemens.com/index.asp?Nr=7427>, under **Downloads**.

Save the files to your computer, and extract the zipped file to an easily accessed location. Launch **SIMATIC PDM – Manager Device Catalog**, browse to the unzipped DD file and select it.

Configuring a new device

1. Set Address (default for PROFIBUS PA is 126; for HART is 0).
 - Press **Right ARROW**  to activate **PROGRAM** mode and open menu level 1.
 - Press **Down ARROW**  repeatedly to navigate to **COMMUNICATION** (menu item 5).
 - Press **Right ARROW**  to display the parameter list.
 - Scroll to **DEVICE ADDRESS** and press **Right ARROW**  to open parameter view.
 - If required, Press **Right ARROW**  to open **Edit** mode. Key in a new value and press **Right ARROW**  to accept it. The LCD displays the new value in parameter view.
 - Press **Mode**  to exit **PROGRAM** mode
2. You will need the most up-to-date Device Description (DD) for your instrument. Launch **SIMATIC PDM – Manager Device Catalog**, browse to the unzipped DD file and select it.
3. Launch SIMATIC Manager and create a new project for LR250. Application Guides for setting up HART and PROFIBUS PA devices with SIMATIC PDM can be downloaded from the product page of our website at: <https://pia.khe.siemens.com/index.asp?Nr=7427>
4. Open the menu **Device – Reset** and click on **Factory Reset**.
5. Upload parameters to the PC/PG.
6. Calibrate the device via the Quick Start Wizard.

Quick Start Wizard steps

Notes:

- The Quick Start settings are not independent parameters. The settings are inter-related, and changes only apply when you click **Transfer** at the end of step 4.
- Do not use the Quick Start Wizard to modify individual parameters: see instead *Parameter Reference* on page 41.
- Click **BACK** to return and revise settings, or **Cancel** to exit the Quick Start.
- The layout of the dialog boxes shown may vary according to the resolution setting for your computer monitor.

Quick Start steps

Note: The layout of the dialog boxes shown may vary according to the resolution setting for your computer monitor.

Launch SIMATIC Manager, create a new project, open the menu **Device – Quick Start**, and follow steps 1 to 5.

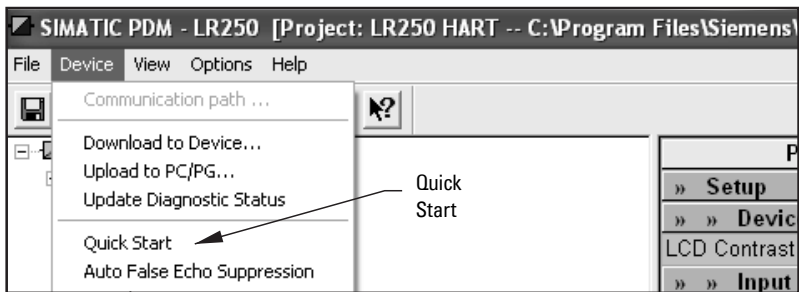

Note: At any stage after step 1, you can click **BACK**, to return and revise settings, or **Cancel** to exit the Quick Start.

Step 1 – Identification

Click **NEXT** to accept the default values. (Description, Message, and Installation Date fields can be left blank.)

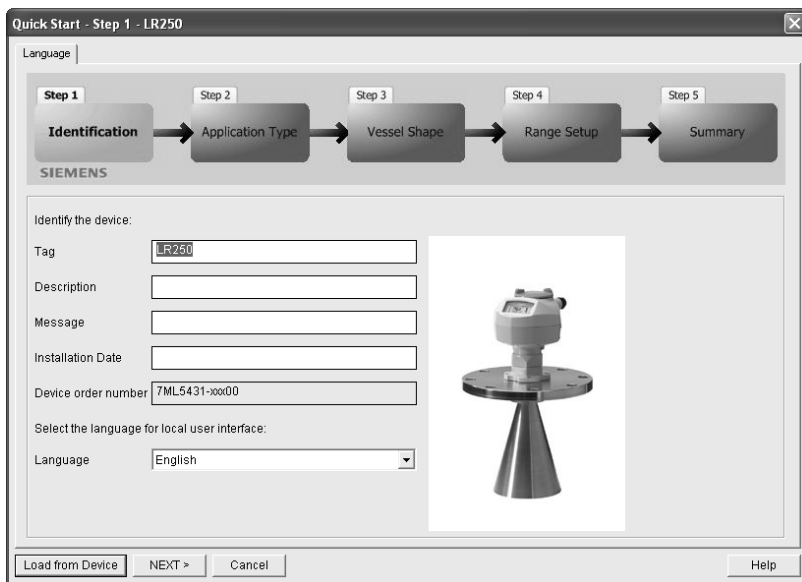

Quick Start - Step 1 - LR250

Language

Step 1 Identification → Step 2 Application Type → Step 3 Vessel Shape → Step 4 Range Setup → Step 5 Summary

SIEMENS

Identify the device:

Tag: LR250

Description: []

Message: []

Installation Date: []

Device order number: 7ML5431-xxx00

Select the language for local user interface:

Language: English

Load from Device | NEXT > | Cancel | Help

Step 2 – Application

Select the application type, and click **NEXT**.



Quick Start - Step 2 - LR250

Application Type

Step 1 Identification → Step 2 Application Type → Step 3 Vessel Shape → Step 4 Range Setup → Step 5 Summary

SIEMENS

Select the Application Type:

Application Type: Level in a vessel

< BACK | NEXT > | Cancel | Help

Step 3 – Vessel Shape

Select the vessel shape, and click **NEXT**.

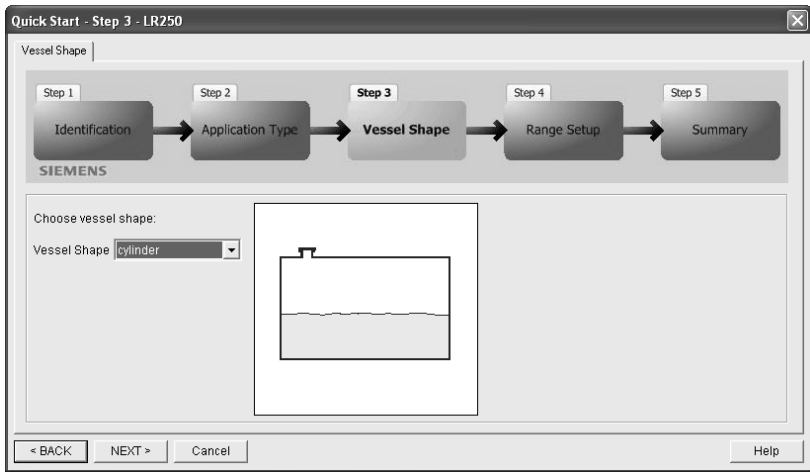

Step 4 – Range

Set the parameters, and click **NEXT**.

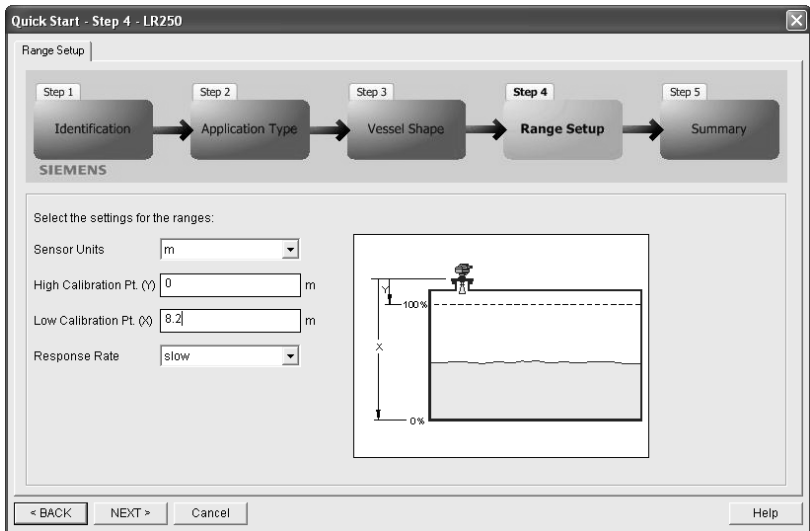

Step 5 – Summary

Check parameter settings, and click **BACK** to return and revise values, or **FINISH** to transfer values to the device.

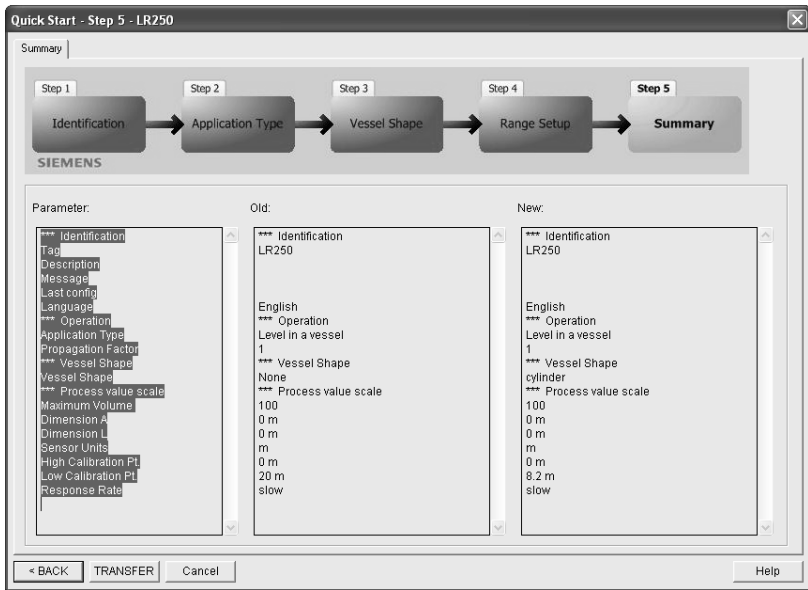

The message **Quick Setup was successful** will appear. Click **OK**.

Using Linearization via the Quick Start wizard

You can use the linearization feature to define a more complex vessel shape and enter up to 32 level breakpoints where the corresponding volume is known. The values corresponding to 100% and 0% levels must be entered. The breakpoints can be ordered from top to bottom, or the reverse.

Ex ample:

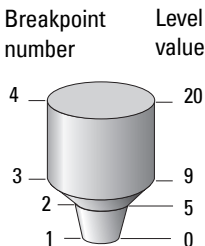

Breakpoint Number	Level value (m)	Volume value (l)
1	0	0
2	5	500
3	9	3000
4	20	8000

Note: values are for example purposes only.

Open the menu Device – Quick Start

1. In **Step 1 – Identification**, press **Next**, to accept default values.
2. In **Step 2 – Application**, select a volume application type, for example **Volume in a vessel**, and press **Next**.
3. In **Step 3 – Vessel Shape**, choose the vessel shape option **Linearization Table** and click **Linearization**.

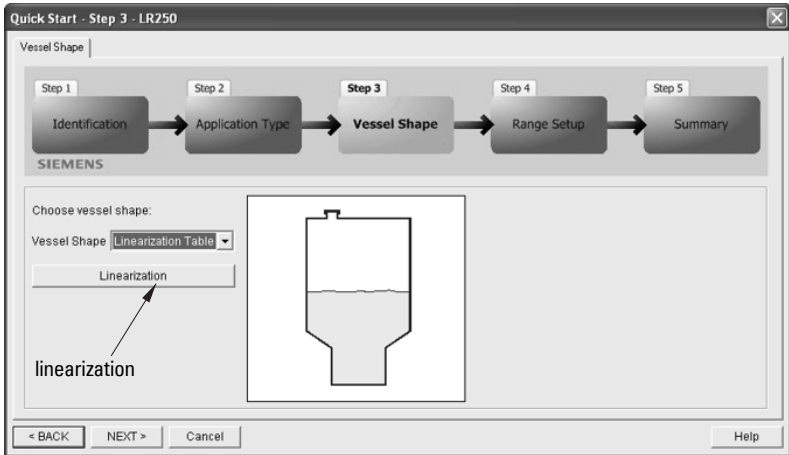

- a. In the **Linearization** window click on the appropriate **Breakpoint** tab to open the dialog window.

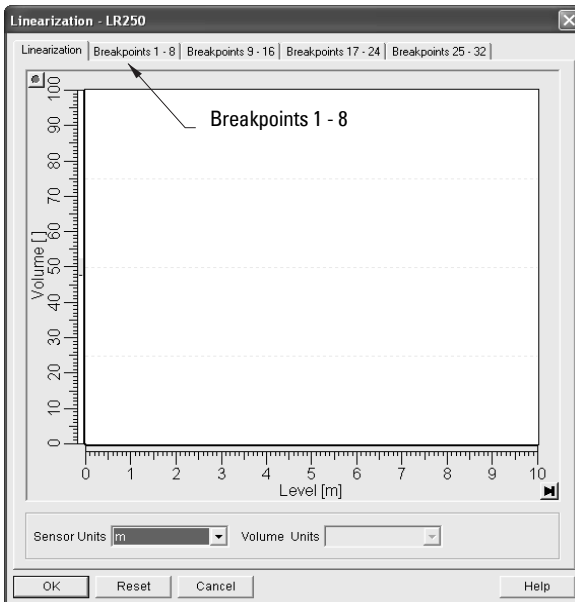

- b. Enter the desired level and volume values, and press **OK**.

Linearization - LR250

Linearization | Breakpoints 1 - 8 | Breakpoints 9 - 16 | Breakpoints 17 - 24 | Breakpoints 25 - 32

Level	Volume
Level(1) <input type="text" value="0.000"/> m	Volume(1) <input type="text" value="0.000"/>
Level(2) <input type="text" value="0.000"/> m	Volume(2) <input type="text" value="0.000"/>
Level(3) <input type="text" value="0.000"/> m	Volume(3) <input type="text" value="0.000"/>
Level(4) <input type="text" value="0.000"/> m	Volume(4) <input type="text" value="0.000"/>
Level(5) <input type="text" value="0.000"/> m	Volume(5) <input type="text" value="0.000"/>
Level(6) <input type="text" value="0.000"/> m	Volume(6) <input type="text" value="0.000"/>
Level(7) <input type="text" value="0.000"/> m	Volume(7) <input type="text" value="0.000"/>
Level(8) <input type="text" value="0.000"/> m	Volume(8) <input type="text" value="0.000"/>

OK Reset Cancel Help

Note: Reset resets values to the values in the offline table.

- c. In the Step 3 window, click **NEXT**.
4. In **Step 4 – Range Setup**, enter parameter values, and click **NEXT**.

Quick Start - Step 4 - LR250

Range Setup

Step 1 Identification → Step 2 Application Type → Step 3 Vessel Shape → **Step 4 Range Setup** → Step 5 Summary

SIEMENS

Select the settings for the ranges:

Sensor Units

High Calibration Pt (Y) m

Low Calibration Pt (X) m

Response Rate

Volume

< BACK NEXT > Cancel Help

- In **Step 5 – Summary**, check parameter values. Click **BACK** to return and revise values, or **FINISH** to transfer values to the device.

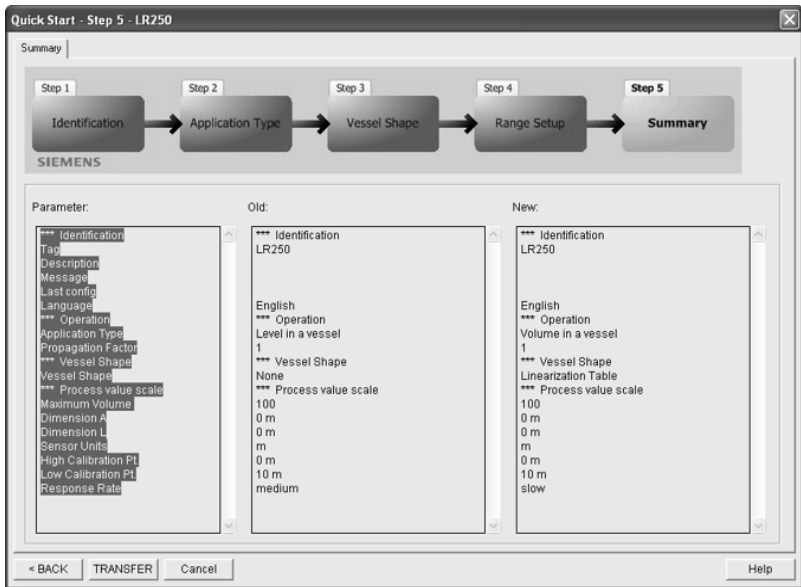

The message **Quick Setup was successful** will appear. Click **OK**.

Local Operation Interface

Note: The complete range of parameters is only accessible via PDM. See *Parameter Reference* on page 47 for a complete list with instructions.

- The handheld programmer allows you to change parameter values and set operating conditions to suit your specific application.
- View settings on the LCD display, or request an echo profile, in PROGRAM mode.
- View the measured value and additional status information, on the LCD display in Measurement mode (RUN mode).

Parameter access

Parameters are identified by name and organized into function groups, then arranged in a hierarchical menu structure (see *LCD menu structure* on page 115). For example:

2. SETUP

2.2. INPUT

2.2.1 SENSOR CALIB

2.2.1.13. RESPONSE RATE

The LCD Display

Measurement mode (RUN mode)

Normal operation

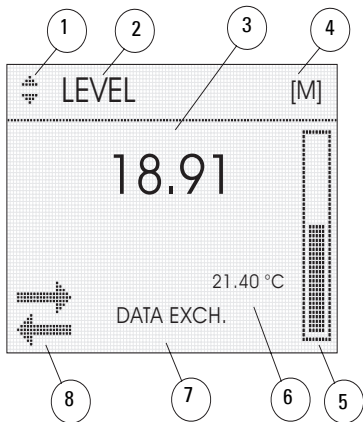

- 1 – measured value (level, space or distance)
- 2 – toggle indicator for linear values or %
- 3 – level, distance, or space
- 4 – units
- 5 – bar graph indicates level
- 6 – secondary region indicates electronics temperature, echo confidence, loop current, or distance in response to a key press. (See *Key functions in Measurement mode* on page 47).
- 7 – text area displays status messages
- 8 – device status indicator

Fault present



S: 0 LOE



S: 53 CONFIG LO

If more than one fault is present, the status indicator and text for each fault alternate at 2 second intervals. See *General Fault Codes* on page 79 for a list.

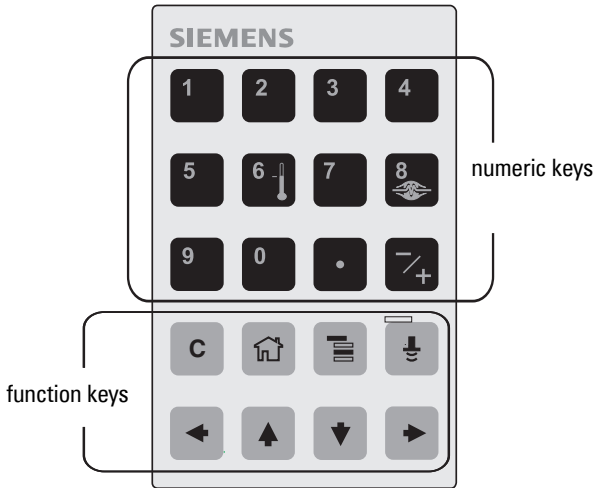

Key functions in Measurement mode

Key	Function	Result
	Updates the loop current.	New value is displayed in LCD secondary region.
	Updates internal enclosure temperature reading.	New value is displayed in LCD secondary region.
	Updates echo confidence value.	New value is displayed in LCD secondary region.
	Updates distance measurement.	New value is displayed in LCD secondary region.
	Mode opens PROGRAM mode.	Opens the menu level last displayed in this power cycle, unless power has been cycled since exiting PROGRAM mode or more than 10 minutes have elapsed since PROGRAM mode was used. Then top level menu will be displayed.
	Right ARROW opens PROGRAM mode.	Opens the top level menu.
	Up or Down ARROW toggles between linear units and percent.	LCD displays measured value in either linear units or percent.

PROGRAM mode display

Navigation view

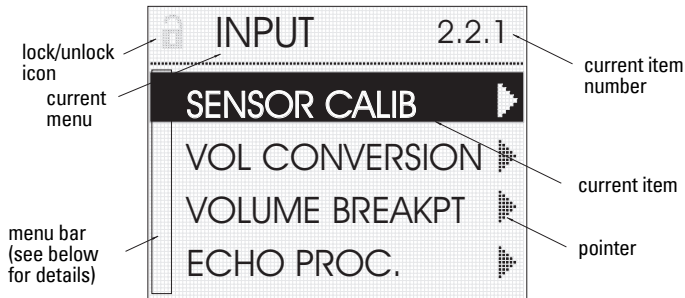

Parameter view

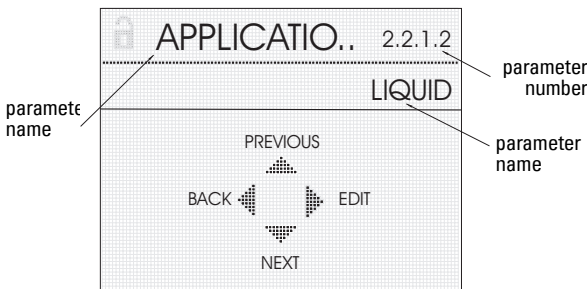

Edit view

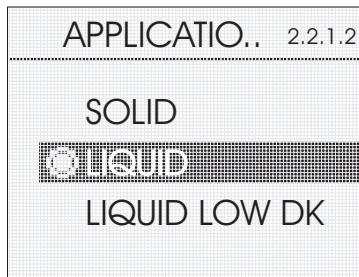

Menu bar in navigation view

- A visible menu bar indicates the menu list is too long to display all items.
- The depth and relative position of the item band on the menu bar indicates the length of the menu list, and approximate position of the current item in the list.
- A deeper band indicates fewer items.
- A band halfway down the menu bar indicates the current item is halfway down the list.

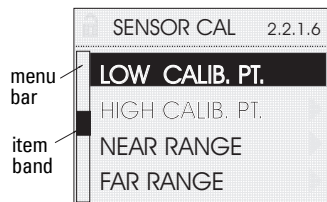

Programming via the handheld programmer



Notes:

- Do not use the Quick Start settings if you want to modify an individual parameter.
- The Quick Start wizard groups the settings required for a simple application into one package and the settings are inter-related.
- Because the settings are inter-related, the initial Quick Start parameter values are not default values and do not necessarily reflect the current device configuration.
- SITRANS LR250 automatically returns to Measurement mode after a period of inactivity in PROGRAM mode (between 25 seconds and 10 minutes, depending on the menu level).

The handheld programmer allows you to change parameter values and set operating conditions to suit your specific application.





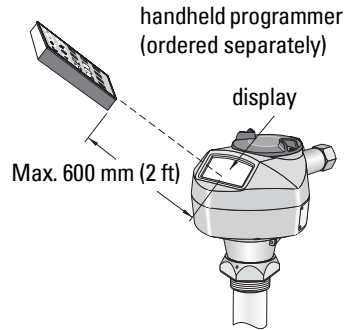

- For the complete list of parameters with instructions, see *Parameter Reference* on page 47.
- See *LCD menu structure* on page 115 for a chart.

1. Enter PROGRAM mode

- Point the programmer at the display (from a maximum distance of 600 mm [2 ft.]).
- **Right ARROW**  activates PROGRAM mode and opens menu level 1.
- **Mode**  opens the menu level last displayed in PROGRAM mode within the last 10 minutes, or menu level 1 if power has been cycled since then.





2. Navigating: key functions in Navigation mode

Key	Name	Menu level	Function
 	Up or Down ARROW	menu or parameter	Scroll to previous or next menu or parameter.
	Right ARROW	menu	Go to first parameter in the selected menu, or open next menu.
		parameter	Open Edit mode.
	Left ARROW	menu or parameter	Open parent menu.
	Mode	menu or parameter	Change to MEASUREMENT mode.
	Home	menu or parameter	Open top level menu at first item: menu 1, item 1.



3. Editing in PROGRAM mode

Selecting a listed option

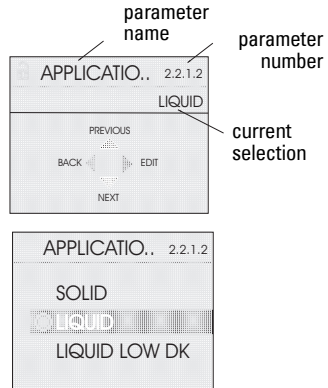
- Navigate to the desired parameter.
- Press **Right ARROW**  to open parameter view.
- Press **Right ARROW**  again to open **Edit** mode. The current selection is highlighted.
Scroll to a new selection.
- Press **Right ARROW**  to accept it
The LCD returns to parameter view and displays the new selection.







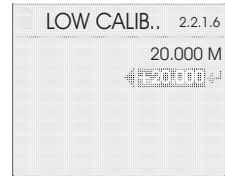
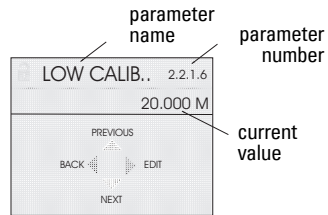



Changing a numeric value

- Navigate to the desired parameter.
- Press **Right ARROW**  to open parameter view. The current value is displayed.
- Press **Right ARROW**  again to open **Edit** mode. The current value is highlighted.
- Key in a new value.
- Press **Right ARROW**  to accept it. The LCD returns to parameter view and displays the new selection.



Key functions in Edit mode

Key	Name	Function	
 	Up or Down ARROW	Selecting options	Scrolls to item.
		Numeric editing	- Increments or decrements digits - Toggles plus and minus sign
	Right ARROW	Selecting options	- Accepts the data (writes the parameter) - Changes from Edit to Navigation mode
		Numeric editing	- Moves cursor one space to the right - or with cursor on Enter sign, accepts the data and changes from Edit to Navigation mode

Key	Name	Function (Cont'd)	
	Left ARROW:	Selecting options	Cancels Edit mode without changing the parameter
		Numeric editing	- Moves cursor to plus/minus sign if this is the first key pressed - or moves cursor one space to the left.
	Clear	Numeric editing	Erases the display.
	Decimal point	Numeric editing	Enters a decimal point.
	Plus or minus sign	Numeric editing	Changes the sign of the entered value.
 to 	Numeral	Numeric editing	Enters the corresponding character.

Echo Profile Viewing

- In PROGRAM mode, navigate to **LEVEL METER > DIAGNOSTICS > ECHO PROFILE**

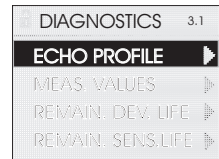

- Press **Right ARROW**  to request a profile.

- In the Profile screen, press **Up ARROW** to select the **Transmit** icon, and **Right ARROW** to update the profile.



transmit icon, selected

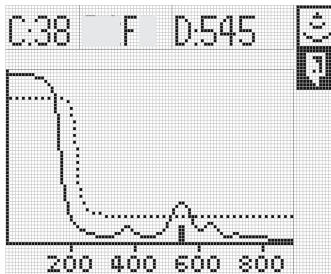

transmit icon, unselected

exit icon, selected

- Press **Down ARROW** to select the **Exit** icon, then **Right ARROW** to return to previous menu.



exit icon, unselected

Operating SITRANS LR250 via SIMATIC PDM

Note: For a complete list of parameters with instructions, see Parameter Reference starting on page 61.

SIMATIC PDM is a software package used to commission and maintain SITRANS LR250 and other process devices. Please consult the operating instructions or online help for details on using SIMATIC PDM. (You can find more information at www.fielddevices.com: go to **Products and Solutions > Products and Systems > Process Device Manager**.)

Functions in SIMATIC PDM

SIMATIC PDM monitors the process values, alarms and status signals of the device. It allows you to display, compare, adjust, verify, and simulate process device data.

For information on adjusting parameter values and viewing the results, see *Alternatively, enter values for Point and Offset directly into the dialog boxes.* on page 56 and *Accessing Functions* on page 57.

SIMATIC PDM Rev. 6.0, SP2 Features

The graphical interface facilitates the following tasks:

- Configuring LR250 for a simple application: see *Quick Start Wizard via SIMATIC PDM* on page 38.
- Volume measurement in an irregular vessel: see *Using Linearization via the Quick Start wizard* on page 42.
- Level monitoring: see *Online Display* on page 53
- Echo monitoring: see *Echo profile saving* on page 56
- Level trend monitoring: see *Alternatively, enter values for Point and Offset directly into the dialog boxes.* on page 56
- False Echo Suppression: see *Auto False Echo Suppression Setup* on page 55 and *Manual TVT Shaper* on page 56.

Accessing Functions

You have access to a number of functions via pull-down menus from the menu bar View menus include: Display (real-time), Echo Profile, and Trend (level over time) diagram, among others.

Online Display

The online display allows you to compare outputs in real time. Open the menu View – Display.

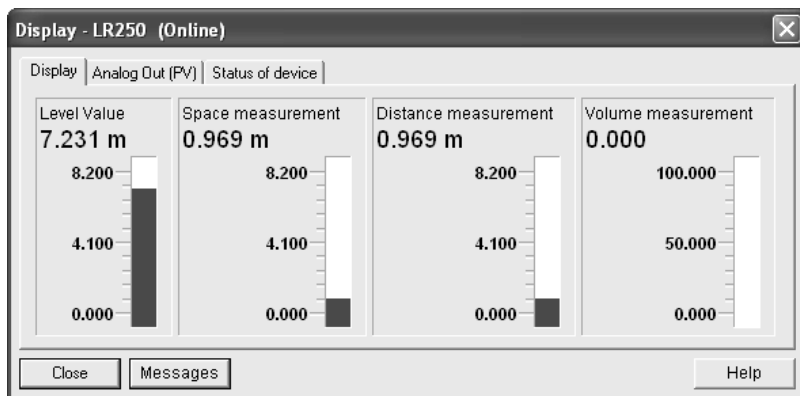

Changing parameter settings using SIMATIC PDM

Note: For a complete list of parameters, see *Parameter Reference* on page 61.

1. Launch SIMATIC PDM, connect to SITRANS LR250, and upload data from the device.
2. Adjust parameter values in the parameter value field then press **Enter**. The status fields read **Changed**.
3. Open the Device menu, click on **Download to device**, then use **File – Save**, to save parameter settings. The status fields are cleared.

The screenshot shows the SIMATIC PDM software interface. On the left is a tree view showing the device structure: LR250 > Level Meter > Setup > Diagnostics > Service > Communication > Security > Language > Certificates and Approvals. The main area displays a table of parameters:

Parameter	Value	Unit	Status
» Setup			
» » Device			
LCD Contrast	4		Initial value
» » Input			
» » » Sensor Calibration			
Antenna	Horn 1.5		Initial value
Application type	Liquid		Initial value
Response Rate	medium		Changed
Sensor Units	m		Loaded
Operation	Level		Initial value
Low Calibration Pt.	10	m	Changed
High Calibration Pt.	0	m	Loaded
Near Range	0.15	m	Loaded

An arrow points from the text "value fields" to the "Value" column of the table.

Parameters accessed via pull-down menus







See *Pull-down menus via SIMATIC PDM* on page 43 for a complete list of parameters that can be accessed only via pull-down menus in SIMATIC PDM.

Configuring a new device

Device Description (DD)

You will need the DD for SIMATIC PDM version 6.0 with SP2. You can locate the DD in Device Catalog, under **Sensors/Level/Echo/Siemens Milltronics/SITRANS LR 460**. If you do not see **SITRANS LR 460** under Siemens Milltronics, you can download the DD from the product page of our website at: <https://pia.khe.siemens.com/index.asp?Nr=14655>, under **Downloads**.

Save the files to your computer, and extract the zipped file to an easily accessed location. Launch **SIMATIC PDM – Manager Device Catalog**, browse to the unzipped DD file and select it.

1. Set Address (default for PROFIBUS PA is 126; for HART is 0).
 - Point the handheld programmer at the display then press **Mode**  to activate **PROGRAM** mode, menu item **1.0**.
 - Press **Down ARROW** , **Right ARROW** , **Right ARROW**  to navigate to Address (menu item **2.1.2**).
 - Press **Right ARROW**  to open Edit mode: the PROGRAM icon  will flash.
 - If required, key in a new value and press **Right ARROW**  to accept it. The LCD displays the new value and the PROGRAM icon disappears.
2. You will need the most up-to-date Device Description (DD) for your instrument. Launch **SIMATIC PDM – Manager Device Catalog**, browse to the unzipped DD file and select it.
3. Launch SIMATIC Manager and create a new project for LR 460. Application Guides for setting up HART and PROFIBUS PA devices with SIMATIC PDM can be downloaded from the product page of our website at: <https://pia.khe.siemens.com/index.asp?Nr=14655>
4. Open the **Menu Device – Reset** and click on **Factory Reset**.
5. Upload parameters to the PC/PG.
6. Calibrate the device.

Calibrating LR 460 via PDM

- See *Quick Start Wizard via SIMATIC PDM* on page 30 and follow 4 steps to setup for a simple application.
- Open the menu **Device – Sensor Calibration** to set parameters individually.
- For a complete list of parameters see *Parameter Reference* on page 43.

Reset

Device Reset

This has the same effect as cycling power. It does not reset any parameters.

Factory Reset

Use **Factory Reset** to reset all parameters excluding device addresses to the default settings.

1. Open the menu **Device – Reset** and click on **Factory Reset**.
2. After the reset is complete upload parameters to the PC/PG.

Configuration Flag Reset (HART only)

To reset the configuration flag to zero, open the menu **Device – Configuration Flag Reset** and execute a reset.

Auto False Echo Suppression

Use this parameter to learn a new TVT curve, to avoid false echoes caused by obstructions. See *Auto False-Echo Suppression* on page 71 for a more detailed explanation, and *Auto False Echo Suppression* on page 74 for instructions

Manual TVT Shaper

Notes:

- For more details, see *Auto False-Echo Suppression* on page 75.
- Double click each axis and record the Xscale and Data Scale values, so that you can restore the default view by resetting to these values.

Open the menu **Device – TVT Shaper**

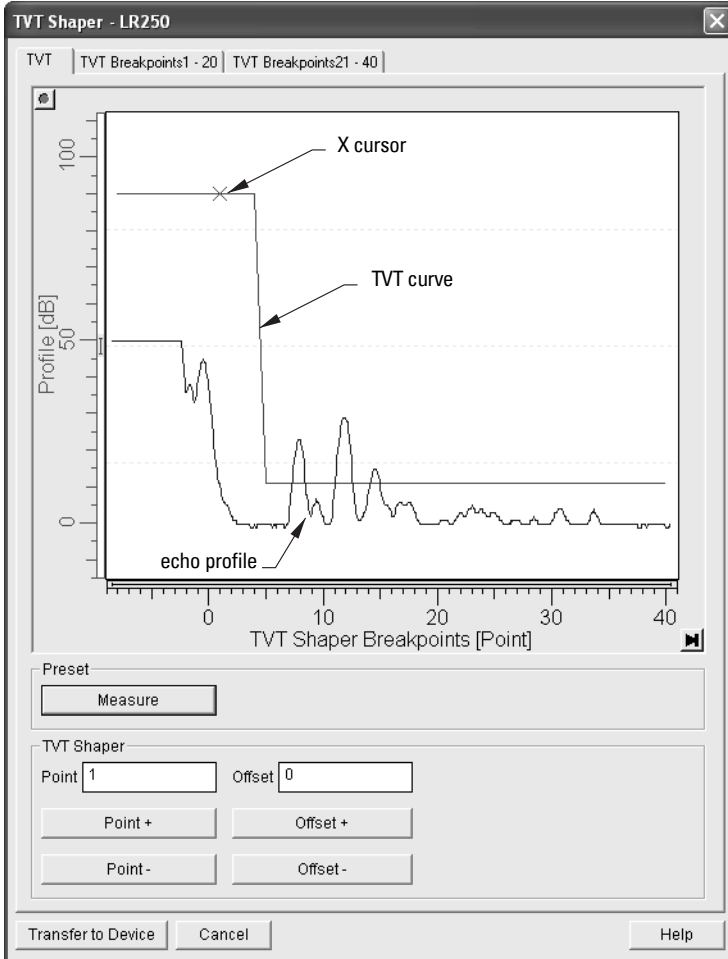

- Change the position of the X cursor on the TVT curve using the **Point+** and **Point-** buttons: raise and lower the curve using **Offset+** and **Offset-**.
- Alternatively, enter values for **Point** and **Offset** directly into the dialog boxes.

Echo profile saving

Notes:

- Double click each axis and record the Xscale and Data Scale values, so that you can restore the default view by resetting to these values.
- You can save a profile or delete a saved profile.
- After saving a profile open menu **View – Show echo profile**.

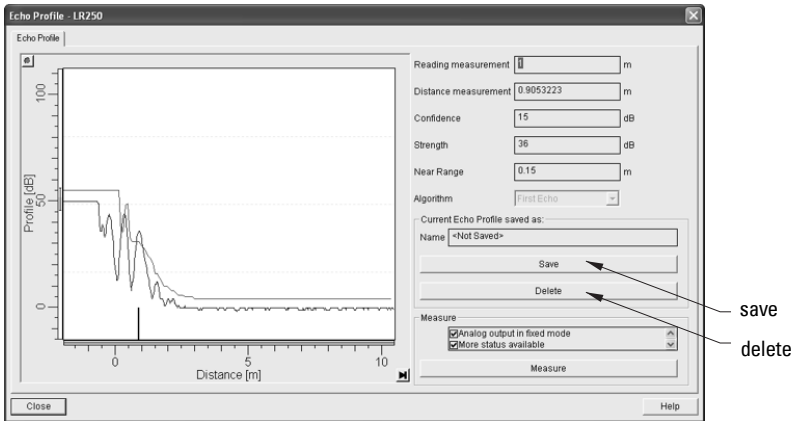

Trend Diagram (Level Trend over Time)

Notes:

- Double click each axis and record the Xscale and Data Scale values, so that you can restore the default view by resetting to these values.

Open the menu **View – Trend**

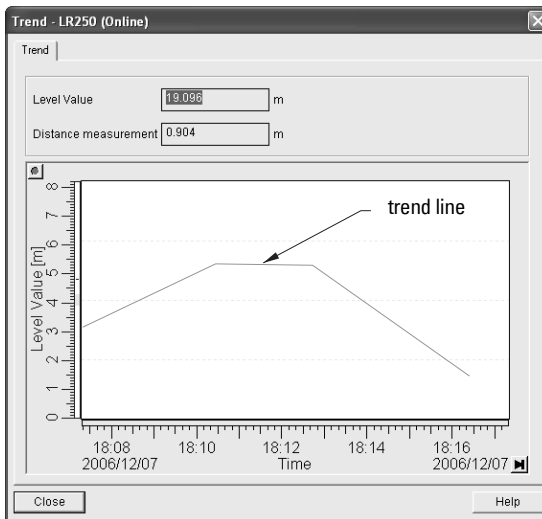

Application Examples

You can use these examples as setup references. Enter the values in the parameter tables to select the corresponding functions.

Example 1: Liquid resin in storage vessel, level measurement

Notes:

- The minimum distance from the flange face to the target is limited by near range 2.2.1.11.
- Only set 2.2.5.6 (Auto False Echo Suppression) if the product is at least 2 m (78") away from the flange face. If it is closer, leave 2.2.5.6 at 1 until the level drops and the distance increases beyond 2 m (78").

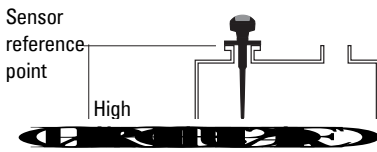

The application is to obtain a level measurement and corresponding 4 to 20 mA output proportional to resin levels in a storage vessel.

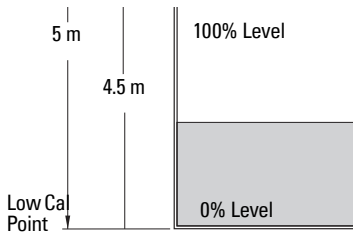

Low Calibration Point is the bottom of the tank, which is 5 m from the antenna flange face. High Calibration Point is 4.5 m from the vessel bottom. The maximum rate of filling or emptying is about 0.2 m/min.

In the event of a loss of echo, SITRANS LR250 is to go into Failsafe Hi after 2 minutes.

Parameter	Description	Value	Function
2.2.1.5	operation	Level	Level
2.2.7.1	measurement response	Med	1 m/minute
2.2.1.4	units	M	meters
2.2.1.6	low calibration point	5	5 m
2.2.1.7	high calibration point	4.5	4.5 m
2.4.1	Failsafe timer	2	2 minutes
2.4.2	Failsafe Material Level	HI	Hi
2.2.5.7	Auto False-Echo Suppression Distance	[Distance ¹ minus 0.42 m]	Sets length of learned TVT curve ² to use
2.2.5.6	Auto False-Echo Suppression	2 then 1	Enables the use of learned TVT curve ² .

1. Distance to product from reference point.

2. For more details see *Range (Auto Suppression Range)* on page 75 and *Auto False Echo Suppression* on page 74.

Return to **Measurement**: press **Mode**  to start normal operation.

Example 2: Horizontal vessel with volume measurement

Notes:

- The minimum distance from the flange face to the target is limited by near range 2.2.1.11.
- Only set 2.2.5.6 Auto False Echo Suppression if the product is at least 2 m (78") away from the flange face. If it is closer, leave 2.2.5.6 at 1 until the level drops and the distance increases beyond 2 m (78").

The application is to obtain a level measurement and corresponding 4 to 20 mA output proportional to vessel volume in a chemical vessel.

Low Calibration Point is the bottom of the tank, which is 3.5 m from the antenna flange face. High Calibration Point is 3.0 m from the vessel bottom. The maximum rate of filling or emptying is about 0.2 m/min. Selecting tank shape i at 2.2.2.1 (Vessel Shape), and entering values for A and L, will give a volume reading instead of level.

In the event of a loss of echo, SITRANS LR250 is to go into Failsafe Hi after 2 minutes.

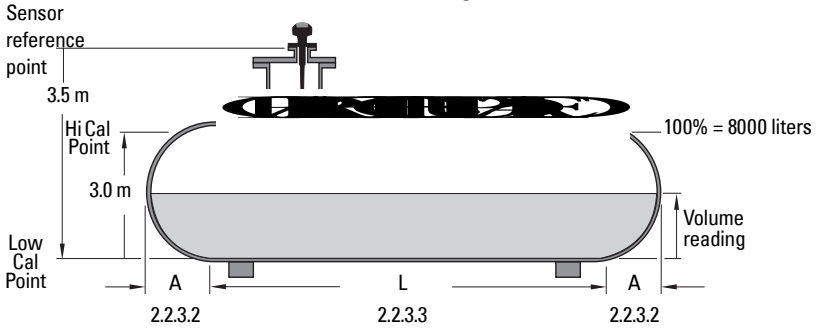

Parameter	Description	Values	Function
2.2.1.5	operation	Level	Volume replaces Level when a tank shape is selected at 2.2.2.1
2.2.7.1	measurement response	Med	1 m/minute
2.2.1.4	units	M	meters
2.2.1.6	low calibration point	3.5	3.5 m
2.2.1.7	high calibration point	3	3 m
2.2.2.1	vessel shape	i	parabolic ends
2.2.3.1	maximum volume	8000	8000 liters
2.2.3.2	vessel dimension A	.8	0.8 meters
2.2.3.3	vessel dimension L	6	6 meters
2.4.1	Failsafe timer	2	2 minutes
2.4.2	Failsafe	HI	Hi
2.2.5.7	Auto False-Echo Suppression Range	[Distance ¹ minus 0.42 m]	Sets length of learned TVT curve ² to use
2.2.5.6	Auto False-Echo Suppression	2 then 1	Enables the use of learned TVT curve ² .

- Distance to product from reference point.
- For more details see *Range (Auto Suppression Range)* on page 75 and *Auto False Echo Suppression* on page 74. For an explanation, see *Auto False-Echo Suppression* on page 108.

Return to **Measurement**: press **Mode**  to start normal operation.

Parameter Reference

Parameters are identified by name and organized into function groups. Menus arranged on up to five levels give access to associated features and options.

Parameters accessible via the handheld programmer are preceded by a number. (See *LCD menu structure* on page 115 for a chart.) [Parameters not preceded by a number are accessible only via SIMATIC PDM.](#)

Some parameters are accessible in SIMATIC PDM via pull-down menus. Where those parameters can also be accessed via the handheld programmer, they are found in the numbered list, and directions for SIMATIC PDM are given beside the individual parameter. Page references for further information can be found under *Pull-down menus via SIMATIC PDM* below.

Pull-down menus via SIMATIC PDM

Device menus	page	View menus	page
Communication path	-	Display	-
Download to device	-	Trend Echo Profile Show Echo Profile Status Read Analog Value Clear Faults Peak Values Wear	
Upload to PC/PG	-		
Update diagnostic status	-		
Quick Start	62		
Auto False Echo Suppression	74		
TVT shaper	76		
Maintenance	87		
Selftest	-		
Reset	87		
Configuration Flag Reset	-		
D/A Trim	42		
Write Locking	48		
Simulate A0	42		
HART Communication	87		
Simulation	42		
Sensor Calibration	50		

Quick Start Wizard

The Quick Start wizard groups together all the settings you need to configure for a simple application.

- The wizard is a complete package and settings are inter-related.
- [Because the settings are inter-related, the initial Quick Start parameter values are not default values and do not necessarily reflect the current device configuration.](#)
- Do not use the wizard to modify individual parameters.
- You can access the Quick Start wizard either via SIMATIC PDM, or via the handheld programmer.

1. Quick Start

1.1. Application Type

Options	LIQUID
	SOLID
	LIQUID LOW DK (low dielectric liquid)

1.2. Response Rate

Sets the reaction speed of the device to measurement changes in the target range.

Options	SLOW	0.1 m/minute
	MED	1.0 m/minute
	FAST	10.0m/minute

Use a setting just faster than the maximum filling or emptying rate (whichever is greater). Slower settings provide higher accuracy; faster settings allow for more level fluctuation

1.3. Sensor Units

Select the units for the Quick Start variables (high and low calibration point, and level, distance, or space).

Options	M, CM, MM, FT, IN
----------------	-------------------

1.4. Operation

Options	NO SERVICE	
	LEVEL	Distance to material surface referenced from Low Calibration Point (process empty level).
	SPACE	Distance to material surface referenced from High Calibration Point (process full level).
	DISTANCE	Distance to material surface referenced from Sensor Reference Point.

Operation types

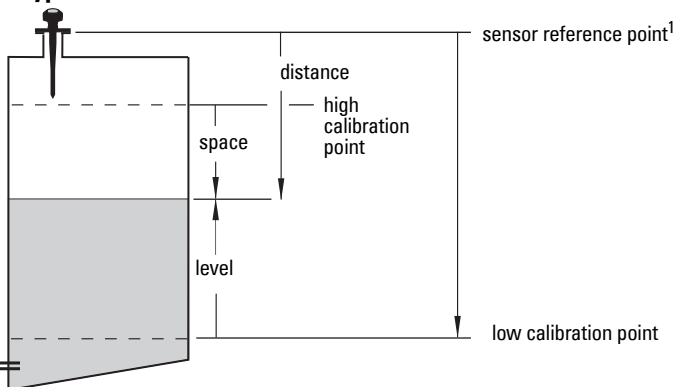

¹ The point from which level measurement is referenced. See *SITRANS LR 200 Dimensions* on page 14 for the standard rod antenna. See *Appendix D: Flange Adapter Versions* on page 83 for other configurations.

1.5. Low Calibration Point

Distance from Sensor Reference to Low Calibration Point: usually process empty level. (See Operation types for an illustration.)

Values	Range: 0.0000 to 20.000 m
---------------	---------------------------

1.6. High Calibration Point

Distance from Sensor Reference to High Calibration Point: usually process full level. (See Operation types for an illustration.)

Values	Range	0.0000 to 20.000 m
---------------	-------	--------------------

1.7. Apply? (Apply changes)

In order to save the Quick Start settings it is necessary to select Yes and apply changes.

Options	YES, NO
----------------	---------

2. Setup

Notes:

- See *Programming via the handheld programmer* on page 32 or *Appendix M: Operating SITRANS LR 200 (PROFIBUS PA) via SIMATIC PDM* on page 118 for instructions.
- Default settings in the parameter tables are indicated with an asterisk (*) unless explicitly stated.
- Values shown in the following tables can be entered via the handheld programmer.

2.1. Device

2.1.1. LCD Contrast

Allows you to adjust the LCD contrast. to improve readability.

Values	Range: 0 (High contrast) to 20 (Low contrast). Default: 8
---------------	--

2.2. Input

2.2.1. Sensor Calibration

2.2.1.1. Antenna

Identifies horn configuration and automatically adjusts the Near Range (blanking) distance to suit.

Options	1.5" horn
	2" horn
	3" horn
	4" horn

Use this parameter to reset the Near Range (blanking) distance, if your horn has to be replaced by one of a different type.

2.2.1.2. Application

Automatically configures the device to operate in the chosen application type, by changing one or more of the following parameters: 2.2.1.14. Propagation Factor, 2.2.4.1.2. Position, and/or 2.2.4.4.3. Low dK Material Tracking.

Options		SOLID
	*	LIQUID
		LIQUID LOW DK (low dielectric liquid)
Related parameters	2.2.1.14. Propagation Factor 2.2.4.1.2. Position 2.2.4.4.3. Low dK Material Tracking	

You can configure each of the related parameters, to suit your particular application.

2.2.1.3. Response Rate

Sets the reaction speed of the device to measurement changes in the target range.

Related parameters	Response Rate	Fill Rate	Empty Rate	
	*	slow	0.1 m/minute	0.1 m/minute
		medium	1 m/minute	1 m/minute
		fast	10 m/minute	10 m/minute

Note: Changing Response Rate resets Fill Rate and Empty Rate.

Use a setting just faster than the maximum filling or emptying rate (whichever is greater). Slower settings provide higher accuracy: faster settings allow for more level fluctuation.

2.2.1.4. Sensor Units

Units the sensor is measuring in.

Values	m, cm, mm, ft, in
	Default: m

2.2.1.5. Operation

Options	NO SERVICE	
	LEVEL	Distance to material surface referenced from Low Calibration Point (process empty level).
	SPACE	Distance to material surface referenced from High Calibration Point (process full level).
	DISTANCE	Distance to material surface referenced from Sensor Reference Point.

Operation types

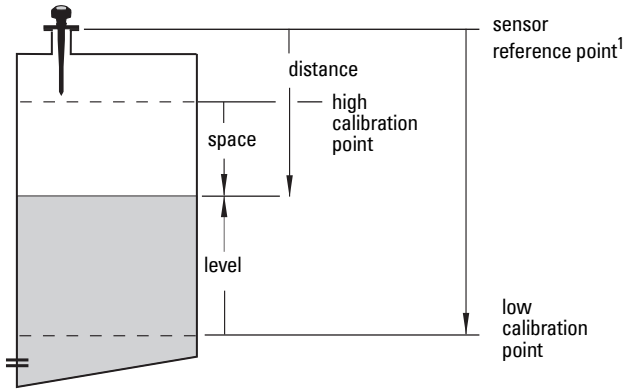

2.2.1.6. Low Calibration Pt.

*Distance from Sensor Reference to Low Calibration Point (corresponding to Low Level Point). Unit is defined in Sensor units. (In SIMATIC PDM, go to Device menu > Sensor Calibration, then click on **Additional Information**, to see an illustration.)*

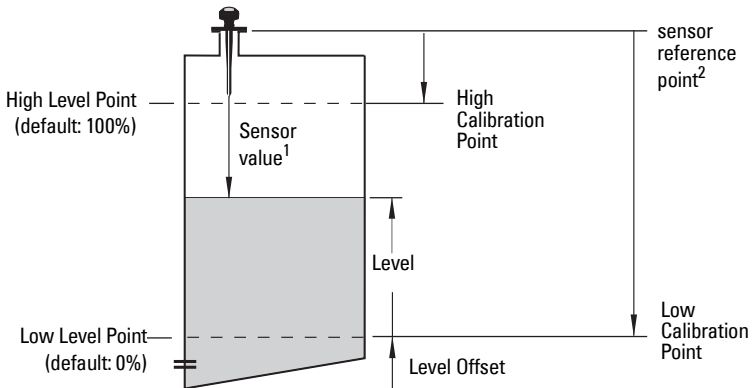

Values	Range: 0 to 20 m. Default 20.000 m
---------------	------------------------------------

¹ The point from which level measurement is referenced. See *SITRANS LR 200 Dimensions* on page 14 for the standard rod antenna. See *Appendix D: Flange Adapter Versions* on page 83 for other configurations.

2.2.1.7. High Calibration Pt.

*Distance from Sensor Reference to High Calibration Point (corresponding to High Level Point). Unit is defined in Sensor units. (In SIMATIC PDM, go to Device menu > Sensor Calibration, then click on **Additional Information**, to see an illustration.)*

Values	Range: 0 to 20 m. Default 0.000 m
---------------	-----------------------------------

2.2.1.12. Near Range

The range in front of the device (measured from the sensor reference point) within which any echoes will be ignored, defined in sensor units. This is sometimes referred to as blanking or a dead zone. The factory set range is dependent on the horn type.

Compensates, for example if the sensor head is changed.

Options	Range: 0 to 20 m	
	Antenna Type	Near Range Default Setting
	1.5" horn	0.185 m (7.28")
	2" horn	0.217 m (8.54")
	3" horn	0.250 m (9.84")
	4" horn	0.305 m (12.01")

2.2.1.13. Far Range

Allows the material level to drop below Low Calibration Point without generating a Loss of Echo (LOE) state, defined in %. This is sometimes referred to as Range Extension.

Options	Range: 0 to >1300 (max. value depends on Low Calibration Point settin). Default 5.000%
----------------	--

Use this feature if the measured surface can drop below the Low Cal. Point in normal operation. Enter value as a percentage of Low Calibration Point.

2.2.1.14. Propagation Factor

Compensates for the change in microwave velocity from propagation in free space. The value is used to compensate for changes in microwave velocity due to propagation within a metal stillpipe, instead of in free space.

Values	Range: 0.3000 to 1.5000
	Default: 1.000

Pipe Size (I.D.) ^a	Propagation Factor
50 mm (2")	0.990
80 mm (3")	0.996
100 mm (4")	0.998
150 mm (6")	0.999
200 mm (8")	1.000

- a. Since pipe dimensions may vary slightly, the propagation factor may also vary.

2. The value produced by the echo processing which represents the distance from sensor reference point to the target.

Note: When operating with a waveguide antenna or stillpipe, values for the parameter *2.2.4.4.3. Low dK Material Tracking* and for the propagation factor should be set according to the antenna/pipe size: see the table below.

Antenna/Pipe Size (I.D.)	50 mm (2")	80 mm (3")	100 mm (4")	150 mm (6")	200 mm (8")
Propagation Factor	0.990	0.9957	0.9965	0.999	0.9994
Low dK material tracking value	Cal Lo – 700 mm	Cal Lo – 1000 mm	Cal Lo – 1000 mm	Cal Lo – 1000 mm	Cal Lo – 1000 mm

2.2.1.15. Level Offset

A constant offset that can be added to Level to form Level output. The unit is defined in Sensor Units.

Values	Default: 0 m
--------	--------------

2.2.2. Volume conversion

Carries out a volume conversion from a level value.

2.2.2.1. Vessel Shape

Defines the vessel shape and allows the LR250 to calculate volume instead of level. If "none" is selected, no volume conversion is performed. Select the vessel shape matching the monitored vessel or reservoir.

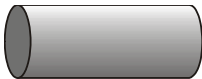
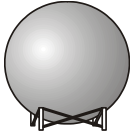
Vessel Shape		Description	Also required
a	*	None	no volume calculation required N/A
b		 flat end horizontal cylinder	maximum volume
c		 sphere	maximum volume

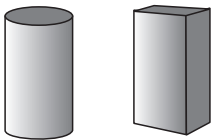
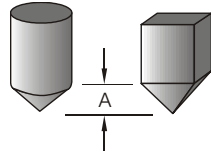
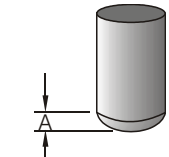
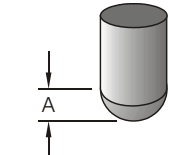
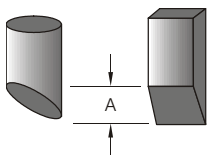
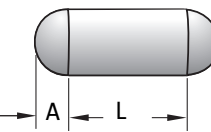
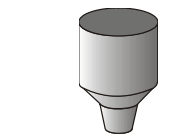
		Vessel Shape	Description	Also required
d			upright, linear (flat bottom)	maximum volume
e			conical or pyramidal bottom	maximum volume, dimension A
f			parabolic bottom	maximum volume, dimension A
g			half-sphere bottom	maximum volume, dimension A
h			flat sloped bottom	maximum volume, dimension A
i			parabolic end horizontal cylinder	maximum volume, dimension A, dimension L
j			linearization table (level/volume breakpoints)	maximum volume, level breakpoints, volume breakpoints

2.2.3. Volume Breakpoints

2.2.3.1. Maximum Volume

The maximum volume of the tank. Enter the vessel volume corresponding to High Calibration Point. For example, if your maximum vessel volume is 8000 L, enter a value of 8000. The units of volume are not entered, but are implied.

Values	Range: 0.0000 to 99999
	Default: 100.0
Related Parameters	Low Calibration Point
	High Calibration Point
	Vessel Shape

2.2.3.2. Dimension A

The height of the vessel bottom in sensor units when the bottom is conical, pyramidal, parabolic, spherical, or flat -sloped. If the vessel is horizontal with parabolic ends, the depth of the end. See 2.2.2.1. Vessel Shape for an illustration.

Values	Range: 0.0000 to 99999 in units
	Default: 0.0
Related Parameters	Vessel Shape

2.2.3.3. Dimension L

Length of the cylindrical section of a horizontal parabolic end vessel, in sensor units. See 2.2.2.1. Vessel Shape for an illustration.

Values	Range: 0.0000 to 99999 in units
	Default: 0.0
Related Parameters	Vessel Shape

2.2.3.4. Table 1-8

If your vessel shape is more complex than any of the preconfigured shapes, you can define the shape as a series of segments. A value is assigned to each level breakpoint and a corresponding value is assigned to each volume breakpoint. Level values are defined in sensor units. Volume units are defined by the user but are not explicitly stated in the SITRANS LR250.

Level Values	Range: 0.0000 to 99999 (m, cm, mm, ft, in)
	Default: 0.0
Volume Values	Range: 0.0000 to 99999
	Default: 0.0

Enter up to 32 level breakpoints, where the corresponding volume is known. The values corresponding to 100% and 0% levels must be entered. The breakpoints can be ordered from top to bottom, or the reverse.

Breakpoints are grouped into four tables: Table 1-8, Table 9-16, Table 17-24, and Table 25-32.

Entering breakpoints via the hand-held programmer:

- Go to the appropriate table for the particular breakpoint you wish to adjust: for example, go to Table 1-8 for breakpoint 1.

- a. Under Table 1-8, go to *2.2.3.4.1. Level 1* to enter the level value for the breakpoint 1.
- a. Under Table 1-8, go to *2.2.3.4.2. Vol 1* to enter the volume value for the breakpoint 1
- a. Repeat steps a to c, till values have been entered for all required breakpoints.

2.2.3.4.1. Level 1

- a. Press **Right ARROW** to open Edit mode.
- b. Enter level value and press **Right ARROW** to accept it.
- c. Press **Down ARROW** to move to corresponding volume breakpoint.

2.2.3.4.2. Vol 1

- a. Press **Right ARROW** to open Edit mode.
- b. Enter volume value and press **Right ARROW** to accept it.
- c. Press **Down ARROW** to move to next level breakpoint.

See example below for illustration.

Example:

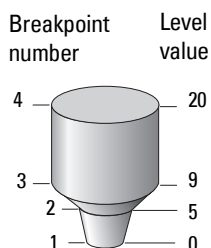

Breakpoint Number	Level value (m)	Volume value (l)
1	0	0
2	5	500
3	9	3000
4	20	8000

Note: values are for example purposes only.

Entering breakpoints via PDM:

- a. Level values are defined in Sensor Units. If you want to change the unit, go to Input > Sensor Calibration > Sensor Units and make a new selection.
- a. Go to > Volume conversion and select Linearization Table option.
- a. Go to > Volume breakpoints > Table 1-8 and enter values for level and volume breakpoints in table.
- a. Repeat step c till values have been entered for all required breakpoints using other tables as required.

2.2.4. Echo Processing

2.2.4.1. Echo select

2.2.4.1.1. Algorithm

Selects the algorithm to be applied to the echo profile to extract the true echo.

Options	*	F	First echo
		L	Largest echo (reserved for SMPI service personnel)
		BLF	Best of Largest or First echo (reserved for SMPI service personnel)

2.2.4.1.2. Position

Note: If dielectric of fluid to be monitored is less than 3, we recommend setting Position to 4 (Hybrid) and [2.2.4.4.3. Low dK Material Tracking](#) to 0.5 m (1.64 ft).

Defines where on the echo the distance measurement is determined.

Options		Center
	*	Hybrid (Center and CLEF)
		CLEF (Constrained Leading Edge Fit)
Related parameters		2.2.4.4. Tank Bottom Algorithm (see below)

2.2.4.1.3. Echo Threshold

Sets the minimum echo confidence that the echo must meet in order to prevent a Loss of Echo condition and the expiration of the LOE timer. When Echo Confidence exceeds the Confidence Threshold, the echo is evaluated.

Values	Range: 0 to 99
	Default: 10
Related Parameters	LOE Timer

Use this feature when an incorrect material level is reported.

2.2.4.2. Sampling

2.2.4.2.1. Echo Lock

Note: Ensure the agitator is always running while SITRANS LR250 is monitoring the vessel, to avoid stationary blade detection.

Selects the measurement verification process.

Options	Lock Off
	Maximum Verification
	* Material Agitator
	Total Lock
Related parameters	Fill Rate Empty Rate Echo Lock Sampling Echo Lock Window Algorithm

If a material agitator or mixer is used in the monitored vessel, Echo Lock should be set for Maximum Verification or Material Agitator to avoid agitator blade detection.

2.2.4.2.4. Sampling up¹

Once echo is outside the window, a specified number of consecutive echoes must appear above the echo locked onto, before measurement is accepted as valid.

2.2.4.2.5. Sampling down¹

Once echo is outside the window, a specified number of consecutive echoes must appear below the echo locked onto, before measurement is accepted as valid.

2.2.4.2.6. Window¹

*A "distance window" centered on the echo, used to derive the reading. When a new measurement is in the window, the window is re-centered and the reading is calculated (see **Display before Auto False Echo Suppression**, page 75 for an illustration).*

When the value is 0, the window is automatically calculated after each measurement.

- For slower Measurement Response values, the window is narrow.
- For faster Measurement Response values, the window becomes progressively wider.

Note: The echo lock window is stored as standard sample, but displayed sensor units. Any value entered for the echo lock window will be rounded to the nearest sample.

¹ This parameter is for use only by Siemens Milltronics service technicians.

2.2.4.3. Filtering

2.2.4.3.3. Damping Filter

The time constant for the damping filter. The engineering unit is always in seconds. This is an exponential filter. When a change occurs in the input, the output will be at 63.2% of the change in one time constant, and will be at full change after 5 time constants

Values	Range: 0 to 100.000 s
	Default: 10.000 m

We recommend setting 2.2.4.1.2. *Position* to 4 (Hybrid Algorithm) and setting 2.2.4.4. *Tank Bottom Algorithm* to 0.5 m (1.64).

2.2.4.4. Tank Bottom Algorithm

2.2.4.4.3. Low dK Material Tracking

Compensates for materials with a low dK value, which may cause the tank bottom to be reported as the level instead of the actual material level at low level conditions.

Values	*	0	Range: 0 to 20 m (0 to 65.6 ft)
		0.5 m	Default: 0.0 m
Related parameters			2.2.4.1.2. <i>Position</i> (see above)

If the dK of the material is less than 3 we recommend setting this parameter to 0.5 m.

2.2.4.5. Noise

2.2.4.5.1. Confidence

Measures echo reliability. It displays the echo confidence of the measurement echo from the last shot. Confidence Threshold defines the minimum criterion for echo confidence.

Values (view only)	0 to 99	
	----	Shot not used
Related Parameters	Confidence Threshold	

Open the menu **View – Profile**.

2.2.4.5.2. Strength

Displays the absolute strength (in dB above 1 μ V rms) of the echo selected as the measurement echo.

Values (view only)	-20 to 99
---------------------------	------------------

Open the menu **View – Profile**.

2.2.4.5.3. Noise Average

Displays the average ambient noise (in dB above 1 μ V rms) of a noise profile. Noise level is a combination of transient noise and receiving circuitry. After a measurement, the values from the previous noise shot will be displayed.

Open the menu **View – Noise**.

2.2.5. TVT (Auto False Echo Suppression) setup

Notes:

- If modifying these parameters via SIMATIC PDM, close all online windows.
- This function works best when the vessel is empty or nearly empty. Use it only if there is a minimum distance of 2 meters from the radar instrument to the material.
- Set Auto False Echo Suppression and Auto False Echo Suppression Distance during startup, if possible.
- If the vessel contains an agitator, the agitator should be running.

*First SITRANS LR250 learns the echo profile. Then the learned profile, or part of the learned profile, is used to screen out false echoes. See *Display before Auto False Echo Suppression* on page 75 for examples.*

2.2.5.1. TVT Hover Level

*Defines in percent how high the TVT (Time Varying Threshold) curve is placed above the echo profile, with respect to largest echo. When SITRANS LR250 is located in the center of the vessel, lower this parameter to prevent multiple echo detections. (For an illustration, see *Display before Auto False Echo Suppression* and *Example after Auto False Echo Suppression*, page 75)*

Values	Range: 0 to 100%
	Default: 40%

2.2.5.6. Auto False Echo Suppression

Enables a 'learned' TVT curve to be used in place of the default TVT curve.

Options	0	Off
	1	On (Enable Auto False Echo Suppression)
	2	"Learn" the TVT curve

Use this feature to ignore false echoes before the material echo. Set Auto Suppression Range first. (See below for an illustration.)

- a. Rotate the instrument for best signal (lower false-echo amplitude).
- b. Go to **Range**, and set the value (see *2.2.5.7. Range (Auto Suppression Range)*).
- c. Open the menu **Device – Auto False Echo Suppression** and select the option to change it.
- d. Select **Learn**. The device will automatically revert to On (Use Learned TVT) after a few seconds.

2.2.5.7. Range (Auto Suppression Range)

Defines the endpoint of the Learned TVT distance. Units are defined in sensor units.

Values	Range: 0.00 to 20.00 m
	Default: 1.00 m

- Go to **Input > TVT Setup > Range**.
- Determine the actual distance from the antenna reference point to the material surface.
- Subtract 0.42 m (16.5") from this distance, and enter the result.

Display before Auto False Echo Suppression

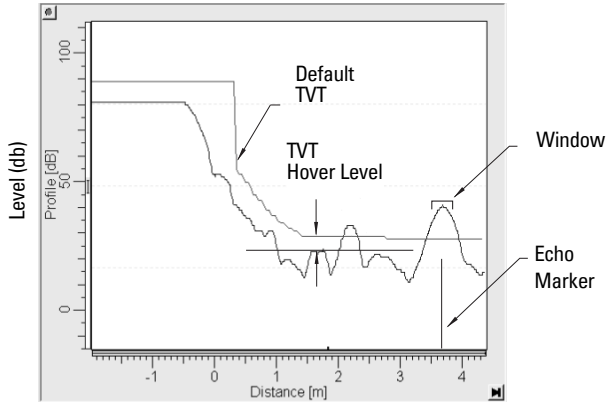

Example after Auto False Echo Suppression

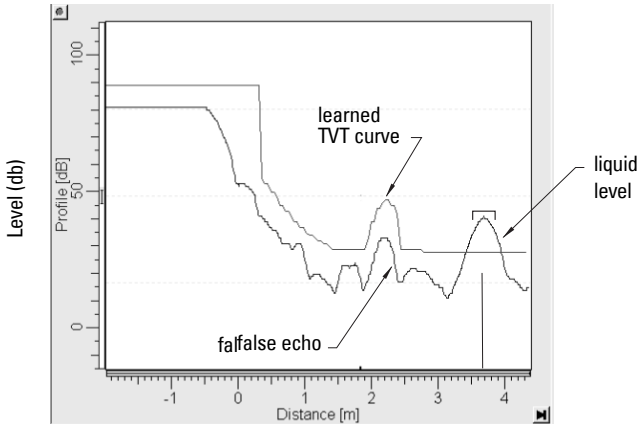

2.2.5.8. Shaper Mode

Adjusts the TVT curve at a specified range.

2.2.6. TVT shaper

A breakpoint on the TVT curve, normalized to 0. This parameter is for authorized Siemens Milltronics service personnel or technicians only.

2.2.6.1. Shaper 1-9

2.2.6.2. Shaper 10-18

2.2.6.3. Shaper 19-27

2.2.6.4. Shaper 28-36

2.2.6.5. Shaper 37-40

Values	Range: 0 to 50 dB
	Default: 0 dB

2.2.7. Rate

2.2.7.1. Response Rate

Sets the reaction speed of the device to measurement changes in the target range.

Options	*	SLOW	0.1 m/minute
		MED	1.0 m/minute
		FAST	10.0m/minute

Use a setting just faster than the maximum filling or emptying rate (whichever is greater). Slower settings provide higher accuracy; faster settings allow for more level fluctuation

2.2.7.2. Fill Rate

Defines the maximum rate at which the reported sensor value is allowed to increase. Allows you to adjust the SITRANS LR250 response to increases in the actual material level. Fill Rate is automatically updated whenever Response Rate is altered.

Values	Range: 0.0000 to 99999 m / min.
	Factory setting: 0.1 m/min.
Altered by	Response Rate
Related parameters	Sensor Units

Enter a value slightly greater than the maximum vessel-filling rate, in Sensor Units per minute.

Options	Meters/Minute
Slow	0.1
Medium	1
Fast	10

2.2.7.3. Empty rate

Defines the maximum rate at which the reported sensor value is allowed to decrease. Adjusts the SITRANS LR250 response to decreases in the actual material level. Empty Rate is automatically updated whenever Response Rate is altered.

Values	Range: 0.0000 to 99999 m / min.
	Factory setting: 0.1
Altered by	Response Rate
Related	Sensor Units

Enter a value slightly greater than the vessel's maximum emptying rate, in Sensor Units per minute.

Options	Meters/Minute
Slow	0.1
Medium	1
Fast	10

2.2.8. Transducer Block (TB) Values (for diagnostic purposes)

2.2.8.1. Reading Measurement

The value for level, or volume (if volume conversion is selected). Read Only.

2.2.8.2. Material Measurement

The value for level. Read Only.

In SIMATIC PDM, open the menu **View – Display**, and select the tab **Display Level Value panel**.

2.2.8.3. Space Measurement

The value for space. Read Only.

In SIMATIC PDM, open the menu **View – Display**, and select the tab **Display Space Measurement panel**.

2.2.8.4. Distance Measurement

The value for distance. Read Only.

In SIMATIC PDM, open the menu **View – Display**, and select the tab **Display Distance Measurement panel**.

2.2.8.5. Volume Measurement

The value for volume. Read Only.

In SIMATIC PDM, open the menu **View – Display**, and select the tab **Display Volume Measurement panel**.

2.2.8.6. Sensor Value

The value of the sensor. Read Only.

In SIMATIC PDM, open the menu **View – Display**, and select the tab **Display Sensor Value**.

2.3. Output

2.3.1. mA Output

2.3.1.1. mA Output Value

The loop current value in mA. Read Only except if the Manual option is chosen in mA Output function below (2.3.1.2).

Values	User Entry only if Manual option is chosen in 2.3.1.2.
	Range: 3.6 mA to 22.6 mA

2.3.1.2. mA Output Function

Alters the mA output/measurement function and allows the output to be set independently.

Options		Manual
	*	Level
		Space
		Distance
		Volume

Notes:

- The mA Output Function is set independently from the setting in Operation. Set Operation first and then mA Output Function. (Operation resets mA Output Function to the same value.)
- The mA Output Function controls the primary value and the loop current for the STIRANS LR250. Use caution when changing the mA Output function when connected to a HART network.
- The mA Output Function also affects the secondary, tertiary and quaternary variables in a HART network.
- mA Output Function must be set to **Manual** before you can modify the mA Output Value (2.3.1.1). Remember to restore your previous setting after using mA Output Function.

2.3.1.3. 4 mA Setpoint

Sets the process level corresponding to the 4 mA value. 4 mA always defaults to 0, and mA Output Function determines whether this is a Level, Space, Distance, or Volume measurement. Level and Space are measured as a percentage of the difference between High Calibration Point and Low Calibration Point. Distance is measured as a percentage of the Low Calibration Point.

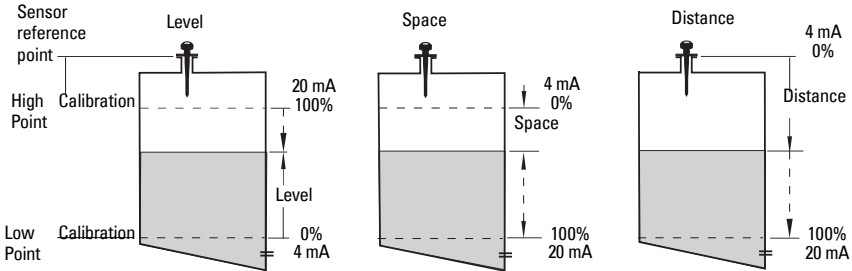

Values	Range: -99999 to 99999 .
	Default: 0.000 m (set to value corresponding to 0% as defined by mA Output Function)
Related Parameters	mA Output Function

Enter the reading that is to correspond to a 4 mA output. Units are defined in Sensor units for Level, Space, or Distance. Units are unspecified for Volume.

2.3.1.4. 20 mA Setpoint

Sets the process level corresponding to the 20 mA value. 20 mA always defaults to 100%, and mA Output Function determines whether this is a Level, Space, or Distance measurement. Level and Space are measured as a percentage of the difference between High Calibration Point and Low Calibration Point. Distance is measured as a percentage of Low Calibration Point.

Values	Range: -99999 to 99999 .
	Default: 19.56 m (set to value corresponding to 100% as defined by mA Output Function)
Related Parameters	mA Output Function

Enter the reading that is to correspond to a 20 mA output. Units are defined in Sensor units for Level, Space, or Distance. Units are unspecified for Volume.

2.3.1.5. Minimum mA limit

Prevents the mA output from dropping below this minimum level for a measurement value. This does not restrict the Failsafe or manual settings..

Values	Range: 3.8 to 20.5 (mA)
	Default: 3.8 (mA)

2.3.1.6. Maximum mA limit

Prevents the mA output from rising above this maximum level for a measurement value. This does not restrict the Failsafe or manual settings.

Values	Range: 3.8 to 20.5 (mA)
	Default: 20.5 (mA)

2.3.1.7. 4 mA Output Trim

Calibrates the 4 mA output. The mA output of the device is pre-calibrated; however, 4 mA Output Trim can be used to trim remote displays or inputs.

Values	Range: 2.0 to 6.0 (mA)
Related parameters	20 mA Output Trim

Steps:

1. Set mA Output Function Manual.
2. Set mA Output Value to 4 mA.
3. Attach a calibrated meter and check the output at the terminals; record the remote reading in mA.
4. Enter this value in 4 mA Output Trim.
5. Restore mA Output Function to previous setting.
6. Confirm that the mA output is as expected.

2.3.1.8. 20 mA Output Trim

Calibrates the 20 mA output. The mA output of the device is pre-calibrated; however, 20 mA Output Trim can be used to trim remote displays or inputs.

Values	Range: 18.0 to 24.0 (mA)
Related parameters	4 mA Output Trim

Steps:

1. Set mA Output Function to Manual.
2. Set mA Output Value to 4 mA.
3. Attach a calibrated meter and check the output at the terminals; record the remote reading in mA.
4. Enter this value in 20 mA Output Trim.
5. Restore mA Output Function to previous setting.
6. Confirm that the mA output is as expected.

2.4. Failsafe

2.4.1. Failsafe Timers

Sets the time to elapse in minutes since the last valid reading, before Failsafe State activates

Values	Range: 0.00 to 720 min.
	Default: 100.0

Note: The last valid reading is maintained until the Failsafe timer expires. After the timer expires, the reading is set based on Failsafe Material Level (next page).

2.4.2. Failsafe Material Level

The material level to be reported when the Failsafe Timer expires.

Values		HI: Use Maximum mA Limit as material level
		LO: Use Minimum mA Limit as material level
	*	HOLD: Level remains at last reading
		VALUE: User-selected value (defined in Failsafe Level below)

2.4.3. Failsafe Level

Defines a user-defined level to report when the Failsafe timer expires..

Values	Range: 3.6 mA to 22.6 mA
	Default: 22.6 mA

Note: Failsafe Material Level must be set to **VALUE** to use this value.

3. Diagnostics

3.1. Echo Profile

Allows you to request the current echo profile either via the handheld programmer, or via SIMATIC PDM.

To request a profile via SIMATIC PDM:

- Open the menu **View – Echo Profile**.
- If desired, press **Save**.
- To view the saved profile, open the menu **View – Show Echo Profile**.

To request a profile via the handheld programmer:

- In PROGRAM mode, navigate to **LEVEL METER > DIAGNOSTICS > ECHO PROFILE**.
- Press **Right ARROW**  to request a profile.

X	DIAGNOSTICS	3.2
	FAULT RESET	
	ECHO PROFILE	
	MEAS. VALUES	▶
	REMAIN DEV. LIFE	▶

- c. In the Profile screen, press **Up ARROW** to select the **Transmit** icon, and **Right ARROW** to update the profile.
- d. Press **Down ARROW** to select the **Exit** icon, then **Right ARROW** to return to previous menu.

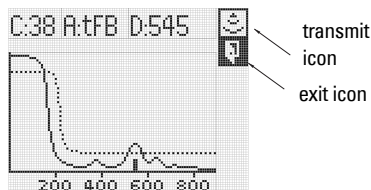

3.14. Measured Values

3.14.1. Current Internal Temperature

Read Only. Displays (in degrees C) the current temperature on the circuit board recorded by the internal electronics.

In SIMATIC PDM, open the menu **Diagnostics**, and select the tab **Measured Values** panel.

3.14.2. Maximum Internal Temperature

Read Only. Displays (in degrees C) the maximum temperature recorded by the internal electronics. The high and low values are maintained over a power cycle.

In SIMATIC PDM, open the menu **Diagnostics**, and select the tab **Measured Values** panel.

3.14.3. Minimum Internal Temperature

Read Only. Displays (in degrees C) the minimum temperature recorded by the internal electronics. The high and low values are maintained over a power cycle.

3.15. Remaining Device Lifetime

Note: Performing a Factory Reset will reset all the Maintenance Schedule parameters to their factory defaults.

Use the Remaining Device/Sensor Lifetime parameters to set up schedules for calibration and maintenance. The device will track itself based on operating hours, instead of a calendar-based schedule, and will monitor its predicted lifetime.

The maintenance warnings and alarms are communicated to the end user through status information. This information can be integrated into any Asset Management system. For optimal use, we recommend that you use SIMATIC PCS7 Asset Management Software in conjunction with SIMATIC PDM.

The device monitors the predicted lifetime of the device.

3.15.1. Total Device Operating Time

Read only. Displays the amount of time the device has been operating.

3.15.2. Remaining Device Lifetime

Read only. The sum of Total Expected Device Life less Total Device Operating Time.

3.15.3. Maintenance Required Limit

Allows you to set the time period after which an alert will signal that maintenance is required.

Values	Range: 0 to 20 years
	Default: 0.164 years

In SIMATIC PDM, open the menu **Device – Maintenance**, click on **Remaining Device Lifetime**.

- a) Enable Alert Activation (see 3.15.5 Maintenance Alert Activation for more detail).
- b) Modify values as required. Click **Write** to accept the changes.

3.15.4. Maintenance Demanded Limit

Allows you to set the time period after which an alert will signal that maintenance is demanded.

Values	Range: 0 to 20 years
	Default: 0.019 years

In SIMATIC PDM, open the menu **Device – Maintenance**, click on **Remaining Device Lifetime**.

- a) Enable Alert Activation (see 3.15.5 Maintenance Alert Activation for more detail).
- b) Modify values as required. Click **Write** to accept the changes.

3.15.5. Maintenance Alert Activation

Select limits to be activated.

Values		Warning Limit 1 (Maintenance Required Limit)
		Warning Limit 2 (Maintenance Demanded Limit)
	*	OFF

To enable or disable Maintenance Alert Activation via PDM:

- a) Open the menu **Device – Maintenance**, click on **Remaining Device Lifetime**.
- b) Select either or both of **Enable Maintenance Required Alert** and **Enable Maintenance Demanded Alert**. Click **Write** to accept the changes.

3.15.6. Total Expected Device Life

The device tries to predict its overall lifetime. The factory default can be reset by the user.

Values	Range: 0 to 20 years
	Default: 10.07 years

To modify the value via PDM, open the menu **Device – Maintenance**, click on **Remaining Device Lifetime**, enter the desired value then click **Write** to accept it.

3.15.7. Maintenance Status

Read only. Displays the status of the Maintenance Alerts

Values	0	No maintenance alerts active
	1	Maintenance Required Alert active
	2	Maintenance Demanded Alert Active

3.15.8. Acknowledge Status

Read only. Displays the status of the Maintenance Alerts that have been acknowledged.

Values	0	No maintenance alerts acknowledged
	1	Maintenance Required Alert acknowledged
	2	Maintenance Demanded Alert acknowledged

3.15.9. Acknowledge

Allows you to acknowledge either a Maintenance Required or a Maintenance Demanded alert.

To acknowledge an alert via PDM:

- Open the menu **View – Device Status** and click on the tab **Maintenance**.
- In the Device Lifetime section, modify values as required. Click **Write** to accept the changes.

3.16. Remaining Sensor Lifetime

The device monitors the predicted lifetime of the sensor (the components exposed to the vessel environment).

3.16.1. Total Sensor Operating Time

Read only. Displays the amount of time the sensor has been operating.

3.16.2. Remaining Sensor Lifetime

Read only. The sum of Total Expected Device Life less Total Device Operating Time.

3.16.3. Maintenance Required Limit

Allows you to set the time period after which an alert will signal that maintenance is required.

Values	Range: 0 to 20 years
	Default: 0.164 years

To modify the value via PDM, open the menu **Device – Maintenance** and click on **Remaining Device Lifetime**.

- Enable Alert Activation (see 3.2.1. Maintenance Alert Activation for more detail).
- Modify values as required. Click **Write** to accept the changes.

3.16.4. Maintenance Demanded Limit

Allows you to set the time period after which an alert will signal that maintenance is demanded.

Values	Range: 0 to 20 years
	Default: 0.019 years

To modify the value via PDM, open the menu **Device – Maintenance** and click on **Remaining Device Lifetime**.

- Enable Alert Activation (see 3.2.1. Maintenance Alert Activation for more detail).
- Modify values as required. Click **Write** to accept the changes.

3.16.5. Maintenance Alert Activation

Select limits to be activated.

Values		Warning Limit 1 (Maintenance Required Limit)
		Warning Limit 2 (Maintenance Demanded Limit)
	*	OFF

To enable or disable Maintenance Alert Activation via PDM:

- Open the menu **Device – Maintenance**, and click on **Remaining Device Lifetime**.
- Select either or both of **Enable Maintenance Required Alert** and **Enable Maintenance Demanded Alert**. Click **Write** to accept the change.

3.16.6. Total Expected Sensor Life

The device tries to predict its overall lifetime. The factory default can be reset by the user.

Values	Range: 0 to 20 years
	Default: 10.07 years

To modify the value via PDM, open the menu **Device – Maintenance**, click on **Remaining Sensor Lifetime**, enter the desired value then click **Write**.

3.16.7. Maintenance Status

Read only. Displays the status of the Maintenance Alerts

Values	0	No maintenance alerts active
	1	Maintenance Required Alert active
	2	Maintenance Demanded Alert Active

To modify the value via PDM, open the menu **Device – Maintenance** and click on **Remaining Device Lifetime**.

- Enable Alert Activation (see 3.2.1. Maintenance Alert Activation for more detail).
- Modify values as required. Click **Write** to accept the changes.

3.16.8. Acknowledge Status

Read only. Displays the status of the Maintenance Alerts that have been acknowledged.

Values	0	No maintenance alerts acknowledged
	1	Maintenance Required Alert acknowledged
	2	Maintenance Demanded Alert acknowledged

3.16.9. Acknowledge

Allows you to acknowledge either a Maintenance Required or a Maintenance Demanded alert.

To acknowledge an alert via PDM:

- Open the menu **View – Device Status** and click on the tab **Maintenance**.
- In the Device Lifetime section, modify values as required. Click **Write** to accept the changes.

4. Service

4.1. Factory Reset

Resets all parameters to their factory settings, with the following exceptions:

- the Lock and Unlock values are not reset.
- The learned TVT curve is not lost.
- In Edit Mode, only the Factory Default performs a Factory Reset. The Idle or Done setting returns you to the previous menu.

Note: Following a Master Reset, complete reprogramming is required.

Options	*	Idle or Done (Return to previous menu)
		Factory Default (Factory Reset Performed)

To perform a factory reset via SIMATIC PDM, open the menu **Device – Master Reset**.

4.2. Powered Hours

Displays the number of hours the unit has been powered up since manufacture.

4.4. Power-on Resets

The number of power cycles that have occurred since manufacture.

4.7. Manufacture Date

The date of manufacture of the SITRANS LR250 (yy mm dd).

4.8. Software Revision

Corresponds to the software or firmware that is embedded in the SITRANS LR250.

4.9. Loader Revision

Corresponds to the software used to update the SITRANS LR250.

4.11. Hardware Revision

Corresponds to the electronics hardware of the SITRANS LR250.

4.12. Memory Test

Allows verification of the RAM, EEPROM, and Flash Memory of the SITRANS LR250.

Values (Read only)	PASS	Memory test successful
	IdLE	No test in progress
	buSY	Test in progress
	FAIL	Test failed
	Fxxxx	Memory address that failed memory test.

Press any numeric key to activate the test. The reading will first display **buSY**, then the test result text.

4.17. Service Interval

Allows for scheduling of service inspections.

4.17.1. Last Time Serviced

Read only. Time elapsed since device was last serviced

4.17.2. Maintenance Required Limit

If the time elapsed from last service is equal to or less than this limit, a Maintenance Required status is generated.

Values	Range: 0 to 20 years
	Default: 0.164 years

4.17.3. Maintenance Demanded Limit

If the time elapsed from last service is equal to or less than this limit, a Maintenance Demanded status is generated.

Values	Range: 0 to 20 years
	Default: 0.019 years

4.17.4. Alert Activation

Select limits to be activated.

Values	*	Timer off
		On - no limits
		On - limits 1 and 2
		On - limit 2

4.17.5. Service Interval

Set time between scheduled service inspections

Values	Range: 0 to 20 years
	Default: 1.0 years

4.17.6. Maintenance Status

Read only. Displays the status of the Maintenance Alerts

Values	0	No maintenance alerts active
	1	Maintenance Required Alert active
	2	Maintenance Demanded Alert Active

4.17.7. Acknowledge Status

Read only. Displays the status of the Maintenance Alerts that have been acknowledged.

Values	0	No maintenance alerts acknowledged
	1	Maintenance Required Alert acknowledged
	2	Maintenance Demanded Alert acknowledged

4.17.8. Acknowledge

Allows you to acknowledge either a Maintenance Required or a Maintenance Demanded alert.

4.18. Calibration Interval

Allows for scheduling of calibrations.

4.18.1. Last Time Calibrated

Read only. Time elapsed since device was last calibrated.

4.18.2. Maintenance Required Limit

If the time elapsed from last calibration is equal to or less than this limit, a Maintenance Required status is generated.

Values	Range: 0 to 20 years
	Default: 0.164 years

4.18.3. Maintenance Demanded Limit

If the time elapsed from last calibration is equal to or less than this limit, a Maintenance Demanded status is generated.

Values	Range: 0 to 20 years
	Default: 0.019 years

4.18.4. Alert Activation

Select limits to be activated.

Values	*	Timer off
		On - no limits
		On - limits 1 and 2
		On - limit 2

4.18.5. Total Calibration Interval

Set time between scheduled calibrations.

Values	Range: 0 to 20 years
	Default: 1.0 years

4.18.6. Maintenance Status

Read only. Displays the status of the Maintenance Alerts

Values	0	No maintenance alerts active
	1	Maintenance Required Alert active
	2	Maintenance Demanded Alert Active

4.18.7. Acknowledge Status

Read only. Displays the status of the Maintenance Alerts that have been acknowledged.

Values	0	No maintenance alerts acknowledged
	1	Maintenance Required Alert acknowledged
	2	Maintenance Demanded Alert acknowledged

4.18.8. Acknowledge

Allows you to acknowledge either a Maintenance Required or a Maintenance Demanded alert.

5. Communication

5.1. Device Address

Sets the device address or poll ID on a HART network. Any address other than 0 will cause the output current to be a fixed value, and the current will not indicate the reading.

Values	Range: 0 to 15
	Default: 0

5.2. Communication Control

Enables the read/write access to parameters via remote communications

Options		Read Only
	*	Read Write
		Restricted

6. Security

6.1. Lock

Note: Do not lose this number value.

Prevents any changes to parameters via the hand-held programmer.

Hand-held programmer Values	1954 (unlock value)	Off (enables local programming)
	any other value	On (disables local programming)

Note: This lock only applies only to the hand-held programmer: it does not lock through communications. A remote master can change configuration if 5.2 Communication Control is set to allow this.

To secure the programming lock: Key in any value other than the unlock value. Parameters are now locked and cannot be changed.

To unlock the device and enable hand-held programming changes: Key in the unlock value. Parameters are now unlocked and may be changed.

6.2. Unlock value

Stores the value to enter in Lock (6.1) to unlock programming. If Lock is on, Unlock Value will not display the unlocked value

Hand-held programmer Values	Range	1 to 9999
	Factory Setting	1954
	----	Display when Lock is on

Notes:

- Default setting for 6.1 (Lock) is Unlocked.
- After a new value is stored in Unlock Value (6.2), that value will be recalled after a Factory Reset.
- Consult your Siemens Milltronics representative if you have forgotten the unlock value.

7. Language

Selects the language to be used on the LCD.

Options	*	English
		German
		French
		Spanish

Appendix A: Alphabetical Parameter List

Parameter Name/Parameter Number/Page Number
<i>20 mA Output Trim</i> (2.3.1.8.) on page 80
<i>20 mA Setpoint</i> (2.3.1.4.) on page 79
<i>4 mA Output Trim</i> (2.3.1.7.) on page 80
<i>4 mA Setpoint</i> (2.3.1.3.) on page 79
<i>Algorithm</i> (2.2.4.1.1.) on page 71
<i>Antenna</i> (2.2.1.1.) on page 63
<i>Auto False Echo Suppression</i> (2.2.5.6.) on page 74
<i>Communication Control</i> (5.2.) on page 90
<i>Confidence</i> (2.2.4.5.1.) on page 73
<i>Current Internal Temperature</i> (3.14.1.) on page 82
<i>Damping Filter</i> (2.2.4.3.3.) on page 73
<i>Dimension A</i> (2.2.3.2.) on page 69
<i>Dimension L</i> (2.2.3.3.) on page 69
<i>Distance Measurement</i> (2.2.8.4.) on page 77
<i>Echo Lock</i> (2.2.4.2.1.) on page 72
<i>Echo Threshold</i> (2.2.4.1.3.) on page 71
<i>Empty rate</i> (2.2.7.3.) on page 77
<i>Factory Reset</i> (4.1.) on page 87
<i>Failsafe Level</i> (2.4.3.) on page 81
<i>Failsafe Material Level</i> (2.4.2.) on page 81
<i>Failsafe Timers</i> (2.4.1.) on page 81
<i>Far Range</i> (2.2.1.13.) on page 66
<i>Fill Rate</i> (2.2.7.2.) on page 76
<i>High Calibration Pt.</i> (2.2.1.7.) on page 66
<i>Language</i> (7.) on page 91
<i>Level Offset</i> (2.2.1.15.) on page 67
<i>Lock</i> (6.1.) on page 91
<i>Low Calibration Pt.</i> (2.2.1.6.) on page 65
<i>mA Output Function</i> (2.3.1.2.) on page 78
<i>mA Output Value</i> (2.3.1.1.) on page 78

Parameter Name/Parameter Number/Page Number
<i>Material Measurement</i> (2.2.8.2.) on page 77
<i>Maximum mA limit</i> (2.3.1.6.) on page 80
<i>Maximum Volume</i> (2.2.3.1.) on page 69
<i>Memory Test</i> (4.12.) on page 87
<i>Minimum mA limit</i> (2.3.1.5.) on page 80
<i>Near Range</i> (2.2.1.12.) on page 66
<i>Noise</i> (2.2.4.5.) on page 73
<i>Operation</i> (2.2.1.5.) on page 65
<i>Position</i> (2.2.4.1.2.) on page 71
<i>Powered Hours</i> (4.2.) on page 87
<i>Power-on Resets</i> (4.4.) on page 87
<i>Propagation Factor</i> (2.2.1.14.) on page 66
<i>Range (Auto Suppression Range)</i> (2.2.5.7.) on page 75
<i>Reading Measurement</i> (2.2.8.1.) on page 77
<i>Response Rate</i> (2.2.7.1.) on page 76
<i>Sampling up</i> (2.2.4.2.4.) on page 72/ <i>Sampling down1</i> (2.2.4.2.5.) on page 72
<i>Sensor Units</i> (2.2.1.4.) on page 64
<i>Software Revision</i> (4.8.) on page 87
<i>Space Measurement</i> (2.2.8.3.) on page 77
<i>Strength</i> (2.2.4.5.2.) on page 73
<i>TVT Hover Level</i> (2.2.5.1.) on page 74
<i>Unlock value</i> (6.2.) on page 91
<i>Vessel Shape</i> (2.2.2.1.) on page 67
<i>Volume Breakpoints</i> (2.2.3.) on page 69
<i>Volume Breakpoints</i> (2.2.3.) on page 69
<i>Volume Measurement</i> (2.2.8.5.) on page 77
<i>Window1</i> (2.2.4.2.6.) on page 72

Appendix B: Programming Chart

Parameter Number and Name	Value
<i>20 mA Output Trim</i> (2.3.1.8.)	
<i>20 mA Setpoint</i> (2.3.1.4.)	
<i>4 mA Output Trim</i> (2.3.1.7.)	
<i>4 mA Setpoint</i> (2.3.1.3.)	
<i>Algorithm</i> (2.2.4.1.1.)	
<i>Antenna</i> (2.2.1.1.)	
<i>Auto False Echo Suppression</i> (2.2.5.6.)	
<i>Communication Control</i> (5.2.)	
<i>Confidence</i> (2.2.4.5.1.)	
<i>Current Internal Temperature</i> (3.14.1.)	
<i>Damping Filter</i> (2.2.4.3.3.)	
<i>Dimension L</i> (2.2.3.3.)	
<i>Distance Measurement</i> (2.2.8.4.)	
<i>Echo Lock</i> (2.2.4.2.1.)	
<i>Echo Threshold</i> (2.2.4.1.3.)	
<i>Empty rate</i> (2.2.7.3.)	
<i>Factory Reset</i> (4.1.)	
<i>Failsafe Level</i> (2.4.3.)	
<i>Failsafe Material Level</i> (2.4.2.)	
<i>Failsafe Timers</i> (2.4.1.)	
<i>Far Range</i> (2.2.1.13.)	
<i>Fill Rate</i> (2.2.7.2.)	
<i>High Calibration Pt.</i> (2.2.1.7.)	
<i>Language</i> (7.)	
<i>Level Offset</i> (2.2.1.15.)	
<i>Lock</i> (6.1.)	
<i>Low Calibration Pt.</i> (2.2.1.6.)	
<i>mA Output Function</i> (2.3.1.2.)	
<i>mA Output Value</i> (2.3.1.1.)	
<i>Material Measurement</i> (2.2.8.2.)	
<i>Maximum mA limit</i> (2.3.1.6.)	
<i>Maximum Volume</i> (2.2.3.1.)	

Parameter Number and Name (Continued)	Value
<i>Memory Test</i> (4.12.)	
<i>Minimum mA limit</i> (2.3.1.5.)	
<i>Near Range</i> (2.2.1.12.)	
<i>Noise</i> (2.2.4.5.)	
<i>Operation</i> (2.2.1.5.)	
<i>Position</i> (2.2.4.1.2.)	
<i>Powered Hours</i> (4.2.)	
<i>Power-on Resets</i> (4.4.)	
<i>Propagation Factor</i> (2.2.1.14.)	
<i>Range (Auto Suppression Range)</i> (2.2.5.7.)	
<i>Reading Measurement</i> (2.2.8.1.)	
<i>Response Rate</i> (2.2.7.1.)	
<i>Sampling up</i> (2.2.4.2.4.)/ <i> Sampling down1</i> (2.2.4.2.5.)	
<i>Sensor Units</i> (2.2.1.4.)	
<i>Software Revision</i> (4.8.)	
<i>Space Measurement</i> (2.2.8.3.)	
<i>Strength</i> (2.2.4.5.2.)	
<i>TVT Hover Level</i> (2.2.5.1.)	
<i>Unlock value</i> (6.2.)	
<i>Vessel Shape</i> (2.2.2.1.)	
<i>Volume Breakpoints</i> (2.2.3.)	
<i>Volume Measurement</i> (2.2.8.5.)	
<i>Window1</i> (2.2.4.2.6.)	

Appendix C: Troubleshooting

Communication Troubleshooting

Generally:

1. Check the following:
 - There is power at the instrument
 - The LCD shows the relevant data
 - The device can be programmed using the hand programmer
2. Verify that the wiring connections are correct.
3. If you continue to experience problems, go to our website at: www.siemens.com/processautomation, and check the FAQs for SITRANS LR250, or contact your local Siemens Milltronics representative.

Specifically:

1. If you try to set a SITRANS LR250 parameter via remote communications, but the parameter remains unchanged:
 - Some parameters can only be changed when the device is not scanning. Try putting the device in PROGRAM mode using the operating mode function.
 - Try setting the parameter from the keypad. (First make sure that the lock parameter [6.1] is set to the unlock value.)
 - The communications control parameter 5.2 must be set to **1** to allow you to write parameters to SITRANS LR250.
2. If you see unanticipated displays, for example:
 - PROGRAM mode displayed instead of Measurement mode
 - the wrong parameter displayed in response to a command
 - a parameter displayed in response to no command

make sure no infrared-capable device is close to SITRANS LR250. Any device with infrared capabilities (laptops, cell phones, PDAs) can cause interference which simulates a command to the SITRANS LR250, potentially causing it to switch modes or to change a parameter.

3. If the operation is erratic, make sure the Hand Programmer is not being used at the same time as SIMATIC PDM.

General Fault Codes

Notes:

- Some faults cause the device to go to Failsafe mode (Fault 52). These are indicated with an asterisk (*).

Fault Codes

Fault Codes			
Code	Meaning	Corrective Action	
S:0	*	The device was unable to get a measurement within the Failsafe Timer period. Possible causes: faulty installation, antenna buildup, foaming/ other adverse process conditions, invalid calibration range.	Ensure installation details are correct. Ensure no antenna buildup. Adjust process conditions to minimize foam or other adverse conditions. Correct range calibration. If fault persists, contact your local Siemens representative.
S:2	*	The device is operating in a low power condition that is outside its operating range. As a result, a valid measurement has not been taken for the failsafe timer period, and the device will be put into failsafe mode.	Correct the power supply (resistance or voltage).
S:3		Device is nearing its lifetime limit according to the value set in Maintenance Required Limit.	Replacement is recommended.
S:4		Device is nearing its lifetime limit according to the value set in Maintenance Demanded Limit.	Replacement is recommended.
S:6		Sensor is nearing its lifetime limit according to the value set in Maintenance Required Limit.	Replacement is recommended.
S:7		Sensor is nearing its lifetime limit according to the value set in Maintenance Demanded Limit.	Replacement is recommended.





C: Troubleshooting

Fault Codes (cont'd)		
Code	Meaning	Corrective Action
S:8	Service interval as defined in Maintenance Required Limit has expired.	Perform service.
S:9	Service interval as defined in Maintenance Demanded Limit has expired.	Perform service.
S:11	Internal temperature sensor failure.	Repair required: contact your local Siemens representative.
S:12	Internal temperature of device has exceeded specifications: it is operating outside its temperature range.	Relocate device and/or lower process temperature enough to cool device. Inspect for heat-related damage and contact your local Siemens representative if repair is required.
S:17	Calibration interval as defined in Maintenance Required Limit has expired.	Perform calibration.
S:18	Calibration interval as defined in Maintenance Demanded Limit has expired.	Perform calibration.
S:28	* Internal device failure caused by a RAM memory error.	Repair required: contact your local Siemens representative.
S:29	* EEPROM damaged.	Repair required: contact your local Siemens representative.
S:31	* Flash error.	Repair required: contact your local Siemens representative.
S:33	* Factory calibration for the internal temperature sensor has been lost.	Repair required: contact your local Siemens representative.
S:34	* Factory calibration for the device has been lost.	Repair required: contact your local Siemens representative.
S:35	* Factory calibration for the device has been lost.	Repair required: contact your local Siemens representative.
S:36	* Unable to start microwave module.	Reset power. If error persists, contact your local Siemens representative.

Fault Codes (cont'd)		
Code	Meaning	Corrective Action
S:37	* Measurement hardware problem.	Reset power. If error persists, contact your local Siemens representative.
S:38	* Failure in the device electronics.	Reset power. If fault persists, contact your local Siemens representative: repair required.
S:43	* Factory calibration for the radar receiver has been lost.	Repair required: contact your local Siemens representative.
S:44	* Factory calibration for the echo slope has been lost.	Repair required: contact your local Siemens representative.
S:45	* No valid boot program detected: firmware corrupt.	Repair required: contact your local Siemens representative.
S:48	* User configuration is invalid. One or more of parameters: Low Calibration Point, High Calibration Point, Volume breakpoints, and/or Auto False-Echo Suppression, are set to invalid values.	Reconfigure the unit. Ensure the difference between High Calibration Point and Low Calibration Point is not less than zero; check the breakpoints (only required if <i>2.2.3. Volume Breakpoints</i> is not set to 0).
S:49	* EEPROM corrupt.	Repair required: contact your local Siemens representative.
S:50	* EEPROM corrupt.	Repair required: contact your local Siemens representative.
S:51	* EEPROM corrupt.	Repair required: contact your local Siemens representative.
S:52	Failsafe is activated. Possible causes: 1) hardware failure; 2) memory failure; 3) Fault 48; 4) failsafe timer expired—possible causes: faulty installation, antenna buildup, foaming/other adverse process conditions, invalid calibration range.	For 3) and 4) Correct configuration; ensure installation is correct; no antenna buildup; adjust process conditions to minimize foaming/other adverse conditions; correct calibration range. If fault persists, or for 1) and 2), contact your local Siemens representative.
S:53	* Configuration lost: one or more parameter settings have been lost. This may occur after a firmware upgrade causes user parameters to be reset.	Restore user parameters using SIMATIC PDM.

Operation Troubleshooting

Operating symptoms, probable causes, and resolutions.

Symptom	Cause	Action
Display flashes LOE and status symbol shows 	level or target is out of range	<ul style="list-style-type: none"> • check specifications • check 2.2.1.6. <i>Low Calibration Pt.</i> • increase 2.2.4.5.1. <i>Confidence</i>
Display flashes LOE and status symbol shows 	material build-up on antenna	<ul style="list-style-type: none"> • clean the antenna • re-locate SITRANS LR250
Display flashes LOE and status symbol shows 	location or aiming: <ul style="list-style-type: none"> • poor installation • flange not level 	<ul style="list-style-type: none"> • check to ensure nozzle is vertical • use 2.2.5.6. <i>Auto False Echo Suppression</i> and check 2.2.5.7. <i>Range (Auto Suppression Range)</i> to ensure nozzle protrudes from end of nozzle.
Display flashes LOE and status symbol shows 	antenna malfunction: <ul style="list-style-type: none"> • temperature too high • physical damage • excessive foam • multiple echoes 	<ul style="list-style-type: none"> • check 3.14.1. <i>Current Internal Temperature</i> • use foam deflector or stilling well • relocate • use a defoamer • set 2.2.4.1.1. <i>Algorithm</i> to F (First echo)

Symptom	Cause	Action (cont'd)
Reading does not change, but the level does	SITRANS LR250 processing wrong echo, i.e. vessel wall, or structural member	<ul style="list-style-type: none"> re-locate SITRANS LR250 check nozzle for internal burrs or welds rotate instrument 90° use <i>2.2.5.6. Auto False Echo Suppression</i> and <i>2.2.5.7. Range (Auto Suppression Range)</i>
Measurement is consistently off by a constant amount	<ul style="list-style-type: none"> setting for <i>2.2.1.6. Low Calibration Pt.</i> not correct setting for <i>2.2.1.15. Level Offset</i> not correct 	<ul style="list-style-type: none"> check distance from flange face to <i>2.2.1.6. Low Calibration Pt.</i> check <i>2.2.1.15. Level Offset</i> or device tag
Screen blank	power error	<ul style="list-style-type: none"> check nameplate rating against voltage supply check power wiring or source
	too much load resistance	<ul style="list-style-type: none"> change barrier type, or remove something from the loop, or increase supply voltage
Reading erratic	echo confidence weak	<ul style="list-style-type: none"> refer to <i>2.2.4.5.1. Confidence</i> use <i>2.2.5.6. Auto False Echo Suppression</i> and <i>2.2.5.7. Range (Auto Suppression Range)</i> use foam deflector or stilling well
	liquid surface vortexed	<ul style="list-style-type: none"> decrease <i>2.2.7.1. Response Rate</i> relocate instrument to side pipe increase confidence threshold in <i>2.2.4.1.3. Echo Threshold</i>
	material filling	<ul style="list-style-type: none"> re-locate SITRANS LR250
Reading response slow	<i>2.2.7.1. Response Rate</i> setting incorrect	<ul style="list-style-type: none"> increase measurement response if possible

Symptom	Cause	Action (cont'd)
Reads correctly but occasionally reads high when vessel is not full	<ul style="list-style-type: none"> detecting close range echo build up near top of vessel or nozzle nozzle problem 	<ul style="list-style-type: none"> clean the antenna use 2.2.5.6. <i>Auto False Echo Suppression</i> and 2.2.5.7. <i>Range (Auto Suppression Range)</i>
Level reading lower than material level	<ul style="list-style-type: none"> material is within near blanking zone vessel near empty and low ϵ_r material multiple echoes processed 	<ul style="list-style-type: none"> decrease 2.2.1.12. <i>Near Range</i> (minimum value depends on antenna type) raise SITRANS LR250 ensure 2.2.4.1.1. <i>Algorithm</i> is set to F (First echo)
	<ul style="list-style-type: none"> nozzle too narrow for length 	<ul style="list-style-type: none"> see <i>Rod Extension Requirements</i> on page 114.

Appendix D: Maintenance

SITRANS LR250 requires no maintenance or cleaning under normal operating conditions.

Under severe operating conditions, the horn antenna may require periodic cleaning. If cleaning becomes necessary:

- Note the antenna material and the process medium, and select a cleaning solution that will not react adversely with either.
- Remove the instrument from service and wipe the antenna clean using a cloth and suitable cleaning solution.

Unit Repair and Excluded Liability

All changes and repairs must be done by qualified personnel, and applicable safety regulations must be followed. Please note the following:

- The user is responsible for all changes and repairs made to the device.
- All new components must be provided by Siemens Milltronics Process Instruments Inc.
- Restrict repair to faulty components only.
- Do not re-use faulty components.

Appendix E: Technical Reference

Principles of Operation

SITRANS LR250 is a sophisticated radar instrument that uses advanced microwave pulse technology¹ to provide non-contacting continuous level measurement in liquids or slurries. Radar level measurement uses the time of flight principle to determine distance to a material surface. The device transmits a signal and waits for the return echo. The transit time is directly proportional to the distance from the material.

Pulse radar uses polarized electromagnetic waves. Microwave pulses are emitted from the antenna at a fixed repetition rate, and reflect off the interface between two materials with different dielectric constants (the atmosphere and the material being monitored). The echo is detected by a receiver, and the transit time is used to calculate level.

Electromagnetic wave propagation is virtually unaffected by temperature or pressure changes, or by changes in the vapor levels inside a vessel. Electromagnetic waves are not attenuated by dust.

SITRANS LR250 consists of an enclosed electronic circuit coupled to an antenna and process connection. The electronic component generates a radar signal (26 GHz) that is directed to the horn.

The signal is emitted from the horn, and the reflected echoes are digitally converted to an echo profile. The profile is analyzed to determine the distance from the material surface to the reference point on the instrument. This distance is used as a basis for the display of material level and mA output.

Echo Processing

The three echo processing parameters, Response Rate, Near Range, and Position, are set to default values shown in the table below. Further information can be found in *Parameter Reference* on the pages shown.

Echo Processing Parameters	Default values	Description	page
<i>2.2.1.3. Response Rate</i>	Fast	measurement response to level change	64
<i>2.2.1.12. Near Range</i>	0	user-defined blanking	66
<i>2.2.4.1.2. Position</i>	Hybrid	Defines where on the echo the distance measurement is determined.	71

The device characterizes all echoes that rise above the TVT (Time Varying Threshold) as potential good echoes. Each peak is assigned a rating based on its strength, area, height above the TVT, amongst other characteristics.

The true echo is selected based on the algorithm selected in *2.2.4.1. Echo select*. Options are Largest Echo, best of Largest and First, or First.

¹ The microwave output level is significantly less than that emitted from cellular phones.

The echo location algorithm calculates the precise time of flight of that echo, and calculates the range using the calibrated propagation velocity (adjusted using a propagation factor, if necessary).

Measurement Response

The measurement response (response rate) limits the maximum rate at which the display and output respond to changes in the measurement. Once the real process fill/empty rate (m/s) is established, a response rate can be selected that is slightly higher than the application rate. The response rate automatically adjusts the filters that affect the output response rate.

There are three preset options: slow, medium, and fast.

2.2.7.1. Response Rate	2.2.7.2. Fill Rate	2.2.7.3. Empty rate	2.2.4.2.1. Echo Lock	2.4.1. Failsafe Timers (time in minutes)	Typical Update Time
Slow	*	0.1 m/min	2	100	###
Medium		1 m/min	2	10	###
Fast		10 m/min	2	1	1 sec.

The measurement response limits the maximum rate at which the display and analog output respond to changes in measurement. Response Rate 2.2.7.1 should be set to a measurement response just faster than the maximum filling or emptying rate (whichever is greater).

When the echoes are received, the relevant echo algorithm (2.2.4.1.1) is applied to determine the true material echo.

Typical Receiver Signal

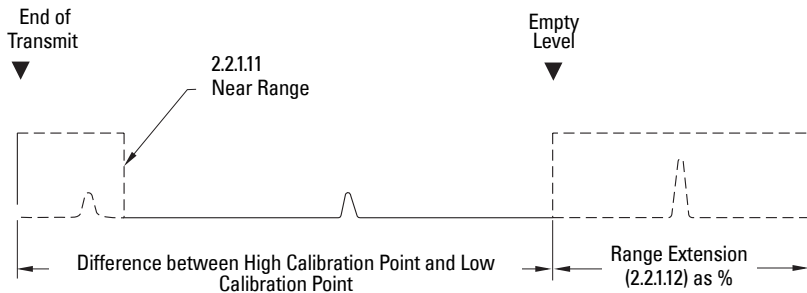

Echo Lock

When the echoes are received, the relevant echo algorithm is applied to determine the true material echo. If the selected echo is within the window, the window is then centered about the echo. Otherwise the window widens with each successive shot until the selected echo is within the window, which then returns to its normal width.

Echo Lock selects the measurement verification process:

Values	0		Off
	1		Maximum Verification
	2	*	Material Agitator
	3		Total Lock

- When Echo Lock is Off, SITRANS LR 250 responds immediately to a new measurement (within the restrictions set by the Maximum Fill / Empty Rate). However, measurement reliability is affected.
- When Maximum Verification or Material Agitator is selected, a new measurement outside the Echo Lock Window must meet the sampling criteria.
- When Total Lock is selected, Echo Lock Window is pre-set to **0**, and the window is automatically calculated after each measurement.

Loss of Echo (LOE)

A loss of echo (LOE) occurs when the calculated measurement is judged to be unreliable because the echo confidence value has dropped below the echo confidence threshold.

If the LOE condition persists beyond the time limit set in *2.4.1. Failsafe Timers* the LCD

displays the Service Required icon, a wrench accompanied by three dots  and the text region displays the fault code **S: 0** and the text LOE.

Fail-safe Mode

Fail-safe Timers

2.4.1. Failsafe Timers determines the time to elapse after the last valid reading before a Fail-safe state is activated. *2.4.2. Failsafe Material Level* determines the level to be reported when the Fail-safe timer expires. Upon receiving a reliable echo, the loss of echo condition is aborted, the Service Required icon and error message are cleared, and the reading and mA output return to the current level.

Fail-safe value

When the *2.4.1. Failsafe Timers* expires, the material level to be reported is determined by *2.4.2. Failsafe Material Level*.

Fail-safe Material Level	
HI	Use Maximum mA Limit as material level
LO	Use Minimum mA Limit as material level
HOLD	Level remains at last reading
VALUE	User-selected value

Far Range (Range Extension)

In applications where the base of the vessel is conical or parabolic, a reliable echo may be available **below** the vessel empty distance, due to an indirect reflection path. Increasing the range extension to 30% or 40% can provide stable empty vessel readings.

False-Echo Suppression

False echoes can appear during the receive cycle. They are often created by internal impediments like a ladder rung, and are usually indicated by an incorrect high level reading.

Near Range (Blanking)

2.2.1.12. *Near Range* programs SITRANS LR250 to ignore the zone in front of the antenna. The default blanking distance is 0.50 mm from end of horn antenna..

Near Range allows you to increase the blanking value from its factory setting. But 2.2.5.6. *Auto False Echo Suppression* is generally recommended in preference to extending the blanking distance from factory values.

Auto False-Echo Suppression

The TVT adjustment parameters allow you to set a TVT (Time Varying Threshold) curve, so that SITRANS LR250 will ignore false echoes.

The default TVT curve hovers above the echo profile, and effectively screens out small false echoes. But if an obstruction is causing a large echo before the material level echo, that echo will rise above the default TVT curve. You can use Auto False-Echo Suppression to filter it out. If possible, rotate the instrument before using Auto False-Echo Suppression, to lower the amplitude of false echoes.

When you set 2.2.5.6 to **Learn**, the instrument learns the echo profile at that moment¹. Then it uses the learned profile instead of the default TVT curve, for the distance set in 2.2.5.7. The learned profile (**Learned TVT curve**) follows the echo profile, so that no large false echoes rise above the learned TVT curve. From the end of the Auto False-Echo Suppression Distance, the default TVT curve is used. The material level echo rises above this, and is selected as the true echo.

For examples, see *Display before Auto False Echo Suppression* on page 109 and *Example after Auto False Echo Suppression* on page 109.

¹ Set 2.2.5.6 to 'Learn' when the material level is substantially lower than process full level (ideally when the tank is empty or almost empty).

Display before Auto False Echo Suppression

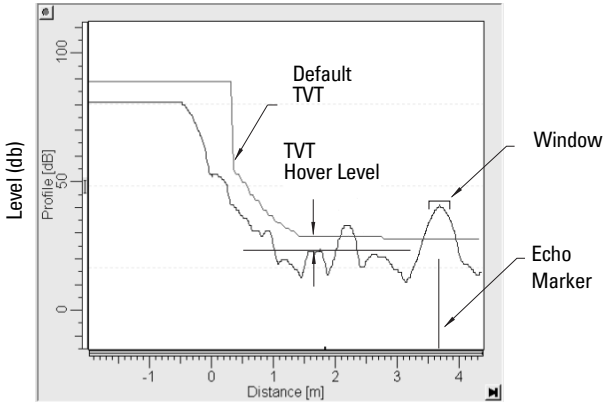

Example after Auto False Echo Suppression

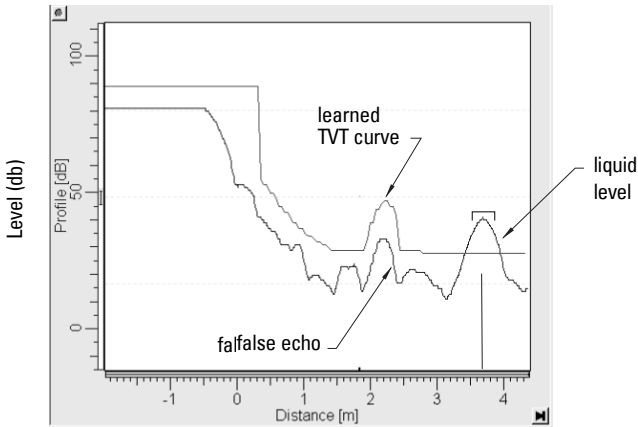

mA Output

The mA output is proportional to the level, in the range 4 to 20 mA. Generally, the output is set so that the output for 0% is 4 mA, and the output for 100% is 20 mA. 0 and 100% are percentages of the full-scale reading (m, cm, mm, ft, in).

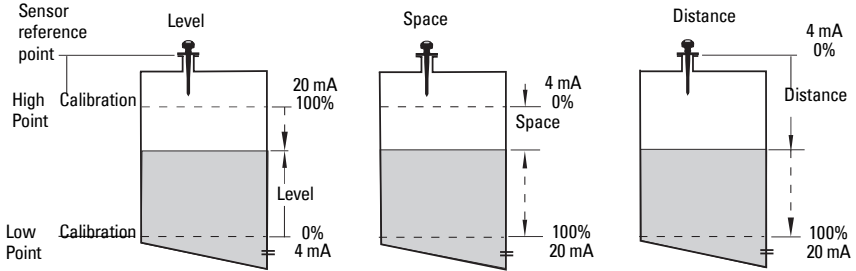

When SITRANS LR250 is put into **PROGRAM** mode it stops responding to the process. It stores the most recent measurement, and holds the associated readings and mA signal output. The instrument reverts to the parameter last addressed during the previous program session.

When the instrument is returned to **Measurement** mode, the transceiver resumes operation. The reading and mA output default to the last measurement taken. The reading and associated outputs migrate to the current process level at a rate controlled by the response rate (2.2.7.1).

If SITRANS LR250 is left in **PROGRAM** mode for 10 minutes without input, it automatically reverts to **Measurement** mode.

Maximum Process Temperature Chart

Note: The chart below is for guidance only:

Maximum Flange and Process Temperatures versus Allowable Ambient for Polypropylene Rod or Flange Adapter versions of SITRANS LR250

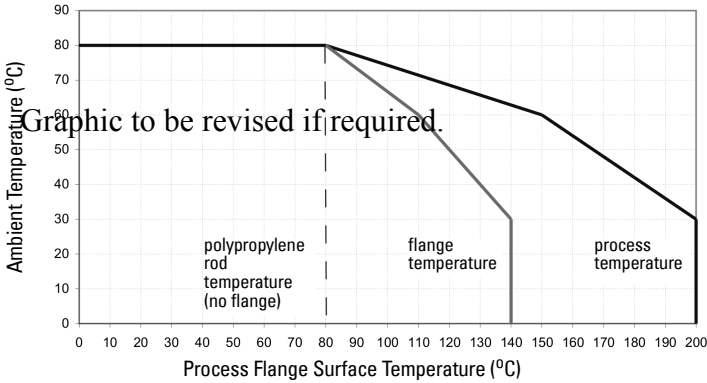

- The chart does not represent every possible process connection arrangement. For example, it will NOT apply if you are mounting SITRANS LR250 on a nozzle greater than 8" nominal, or directly on a metallic vessel surface.
- The chart does not take into consideration heating from direct sunshine exposure.

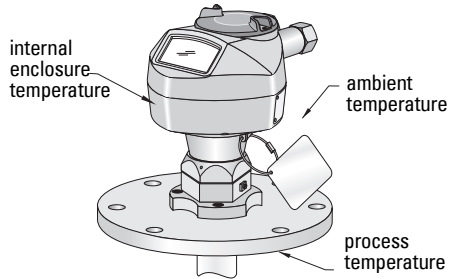

Where the chart does not apply, please use your own judgement regarding the use of SITRANS LR250. Parameter 3.14.1 is required to monitor the Internal Temperature. It gives you an excellent indication of how reliably the product will perform thermally when installed on your process vessel.

3.14.1 also allows you to decide whether or not attention should be focussed on redesigning the installation. For example, if the internal temperature exceeds the maximum allowable limit, a sun shield or a longer nozzle may be required. Engineering will use this temperature reading (3.14.1) to gauge the extent of change required to the installation in order to provide a reliable thermal-operating zone for the SITRANS LR250.

! WARNING: Internal temperature must not exceed 80 °C (176 °F).

Process Pressure/Temperature derating curves

Notes:

- These configurations are subject to revision: other options may be added.
- Process configuration numbers are not final.
- The Process Device Tag shall remain with the process pressure boundary assembly¹. In the event the instrument package is replaced, the Process Device Tag shall be transferred to the replacement unit.
- SITRANS LR 250 units are hydrostatically tested, meeting or exceeding the requirements of the ASME Boiler and Pressure Vessel Code and the European Pressure Equipment Directive.
- The serial numbers stamped in each process connection body, (flange, threaded, or sanitary), provide a unique identification number indicating date of manufacture. Example: MMDDYY – XXX (where MM = month, DD = day, YY = year, and XXX= sequential unit produced)
Further markings (space permitting) indicate flange configuration, size, pressure class, material, and material heat code.



WARNINGS:

- **Never attempt to loosen, remove or disassemble process connection or instrument housing while vessel contents are under pressure.**
- **This product is designated as a Pressure Accessory per Directive 97/23/EC and is not intended for use as a safety device.**
- **Materials of construction are chosen based on their chemical compatibility (or inertness) for general purposes. For exposure to specific environments, check with chemical compatibility charts before installing.**
- **The user is responsible for the selection of bolting and gasket materials which will fall within the limits of the flange and its intended use and which are suitable for the service conditions.**
- **Improper installation may result in loss of process pressure and/or release of process fluids and/or gases.**

¹ The process pressure boundary assembly comprises the components that act as a barrier against pressure loss from the process vessel: that is, the combination of process connection body and emitter, but normally excluding the electrical enclosure.

Horn Antenna or Wave Guide – ANSI Hole Pattern, 150#¹

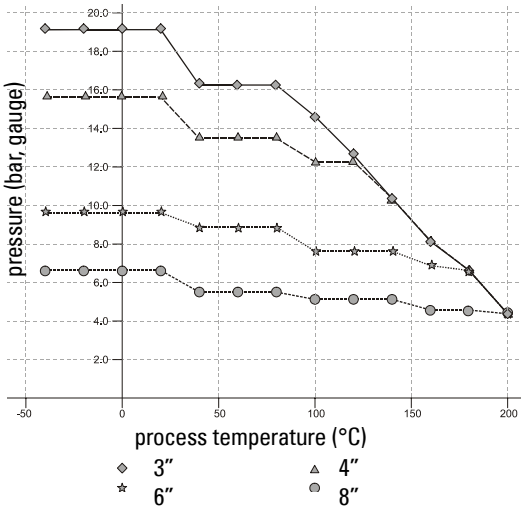

- Process Connection Series:
- 51242 to 51???, and 512xx to 512xx, with 25546 and 255xx series flange.
 - Ensure your instrument has the process identification tag showing one of this series, and 25546 or 255xx stamped on flange.
 - Reference drawing number is shown on the process device tag. You can find this drawing on our website: www.siemens.com/processautomation on the LR 250 product page, under Process Connection Specifications.

Horn Antenna or Wave Guide DN Hole Pattern, PN16²

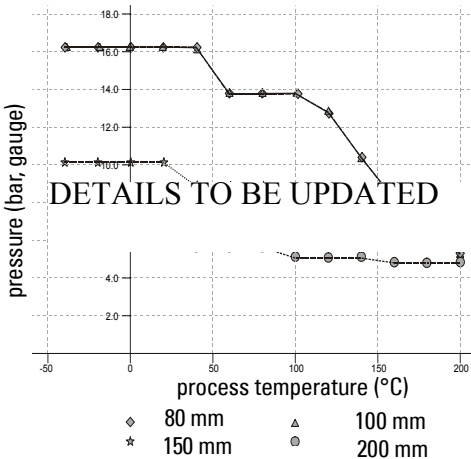

- Process Connection Series:
- 51242 to ????, and 512xx to 51512xx with 25547 and 255xx series flange.
 - Ensure your instrument has the process identification tag showing one of this series, and 25547 or 255xx stamped on flange.
 - Reference drawing number is shown on the process device tag. You can find this drawing on our website: www.siemens.com/processautomation on the LR 250 product page, under Process Connection Specifications.

! WARNING: Never attempt to loosen, remove or disassemble process connection or instrument housing while vessel contents are under pressure.

1. Customer to provide adequate bolting and flat-faced gasket to retain vessel pressure and provide sufficient sealing.
2. Customer to provide adequate bolting and flat-faced gasket to retain vessel pressure and provide sufficient sealing.

Appendix F: Loop power

Typical Connection Drawing

Note: Loop voltage is the voltage at the terminals of the power supply (not the voltage at the terminals of the device).

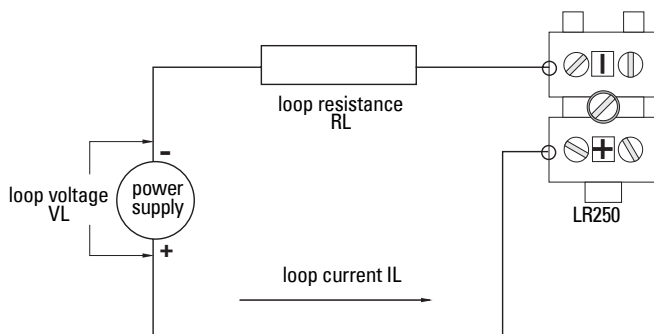

Allowable operating area of SITRANS LR250

Curve 1 (General Purpose, Intrinsically Safe, Non-incendive)

Loop Voltage versus Loop Resistance

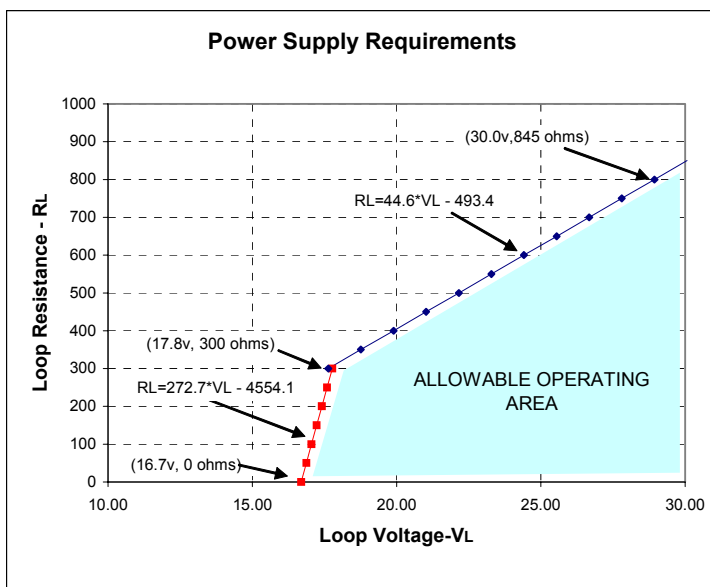

Curve 2 (Flameproof, Increased Safety, Explosion-proof)

Loop Voltage versus Loop Resistance

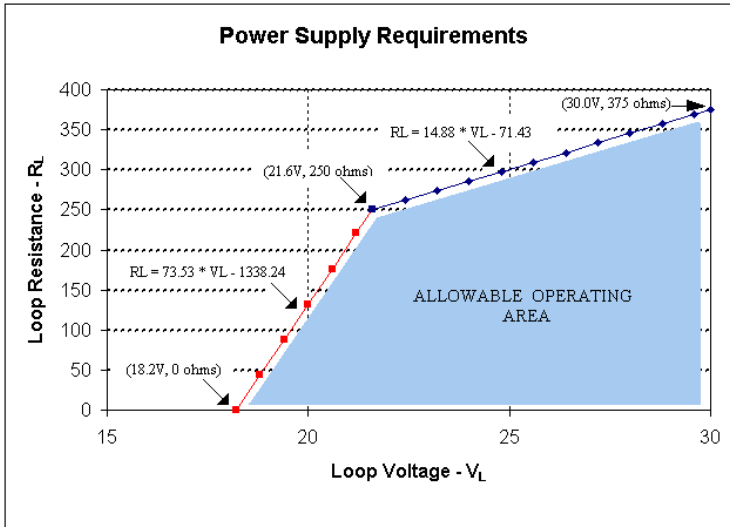

Startup Curve

Typical Start up behaviour of the LR 200

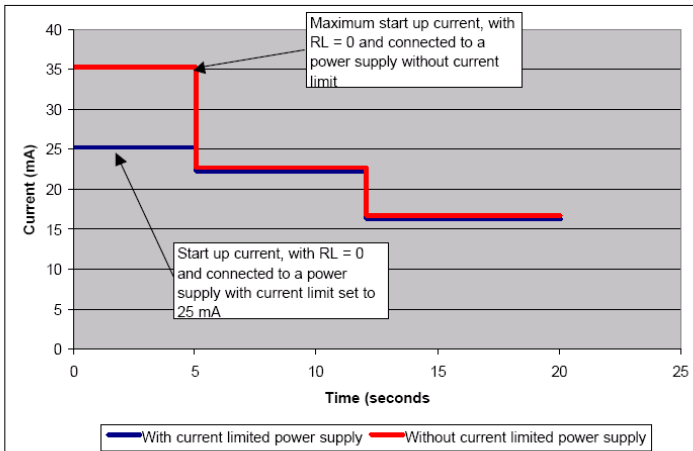

Notes:

- The LR 200 is designed to start reliably with a power supply capable of delivering at least 25 mA.
- When connected to a power supply with a current limit of < 25 mA, the LR 200 may not start reliably

Appendix G: Special Applications

This more complex SITRANS LR250 application example can be used for setup references.

Application Example: Stillpipe

This is used for products with an ϵ_r of less than 3, or if extremely turbulent or vortex conditions exist. This mounting arrangement can also be used to provide optimum signal conditions on foaming materials.

Notes:

- For $\epsilon_r < 3$, the lower 400 mm of vessel level may not be measurable.
- 2.2.1.12. *Near Range* (Blanking) will be set at the factory. Check the process device tag for specific values.
- Suitable pipe diameters are 50 mm (2") to 100 mm (4"): See the chart on page 108 for typical 2.2.1.14. *Propagation Factor* values.

This application is to obtain a level measurement and corresponding 4 to 20 mA output proportional to the oil level in a fuel storage vessel.

- The reference point of SITRANS LR250 is 5 m (16.5 ft) from the vessel bottom.
- Low Calibration Pt. is 0 m/ft (bottom of tank).
- High Calibration Pt. is 4.5 m (14.74 ft) from the bottom.
- The stillpipe inside diameter is 100 mm (4").
- The maximum rate of filling or emptying is about 0.1 m (4")/min.

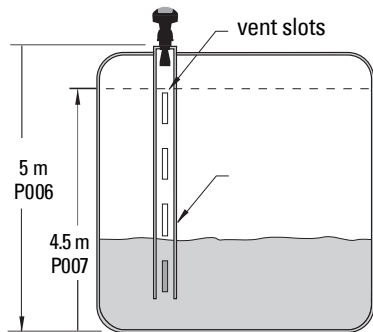

Parameter	Enter	
2.2.1.5. <i>Operation</i>	1	= level
2.2.7.1. <i>Response Rate</i>	2	= 1 m/minute
2.2.1.4. <i>Sensor Units</i>	1	= meters
2.2.1.6. <i>Low Calibration Pt.</i>	5	= 5 m
2.2.1.7. <i>High Calibration Pt.</i>	4.5	= 4.5 m
2.2.1.14. <i>Propagation Factor</i> ¹	0.998	= 100 mm pipe I.D.
2.2.5.7. <i>Range (Auto Suppression Range)</i>	distance to material – 0.42 m	
2.2.5.6. <i>Auto False Echo Suppression</i>	2	enable false-echo suppression

¹ See under 2.2.1.14. *Propagation Factor* on page 66 for a table showing suggested values.

Appendix H: HART Communications

Highway Addressable Remote Transducer, HART, is an industrial protocol that is superimposed on the 4-20 mA signal. It is an open standard, and full details about HART can be obtained from the HART Communication Foundation at www.hartcomm.org

SITRANS LR250 Rev 3 can be configured over the HART network using either the HART Communicator 375¹ by Fisher-Rosemount, or a software package. The recommended software package is the SIMATIC Process Device Manager (PDM) by Siemens.

SIMATIC PDM

This software package is designed to permit easy configuration, monitoring, and troubleshooting of HART devices. The HART DD for SITRANS LR250 was written with SIMATIC PDM in mind and has been extensively tested with this software.

For more information, see *Operating SITRANS LR250 via SIMATIC PDM* on page 52.

HART Device Description (DD)

In order to configure a HART device, the configurator must have the HART Device Description for the instrument in question. HART DDs are controlled by the HART Communication Foundation. Please check with the HART Communication Foundation for the availability of the HART DD for SITRANS LR250. Older versions of the library will have to be updated in order to use all the features of SITRANS LR250.

¹ Versions of SITRANS LR250 earlier than Rev. 3 can be configured using the HART Communicator 275.

HART Communicator 375

Notes:

- HART Communicator 375 is supported by SITRANS LR250 HART Rev. 3.03. The menu structure is aligned with the menu structure of SIMATIC PDM.

Chart 1

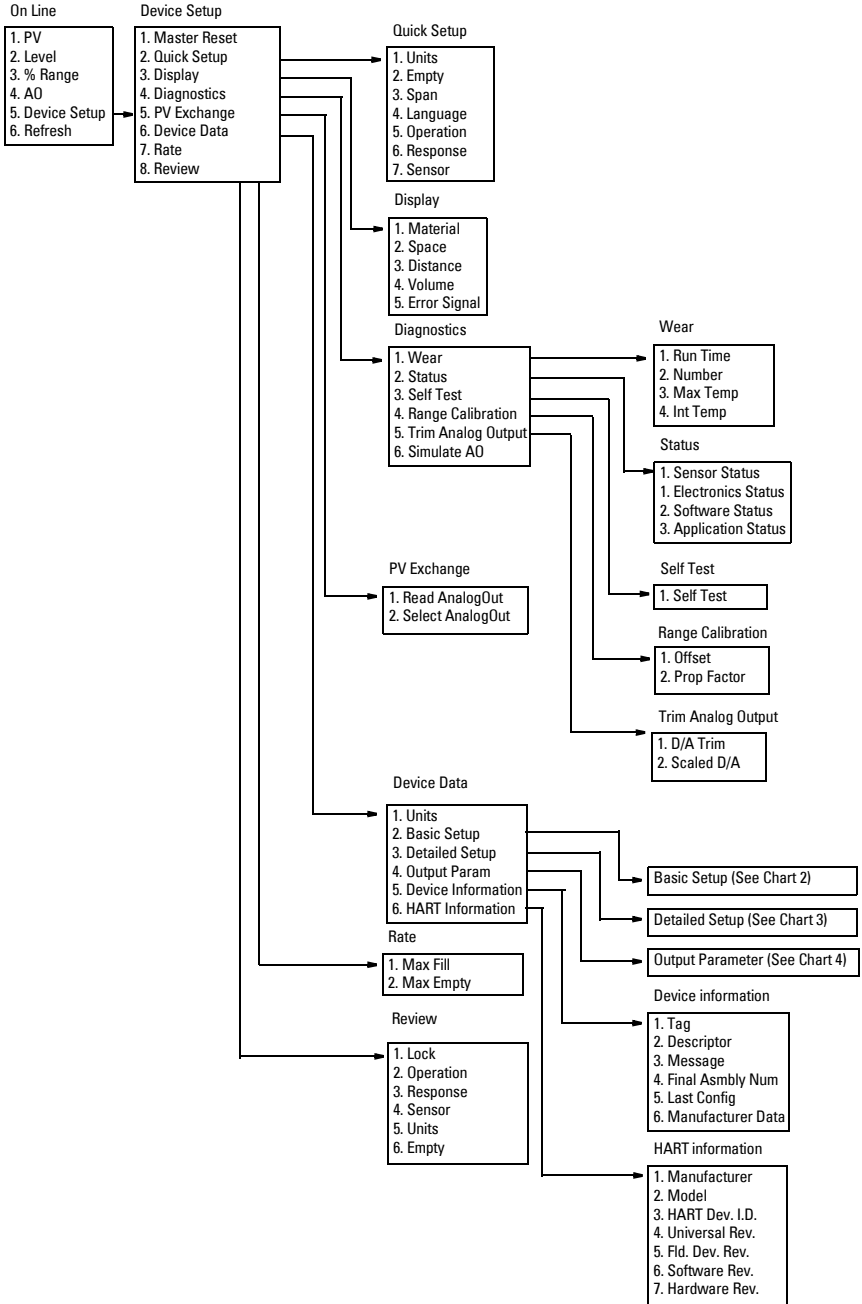

H: HART Communications

Chart 2

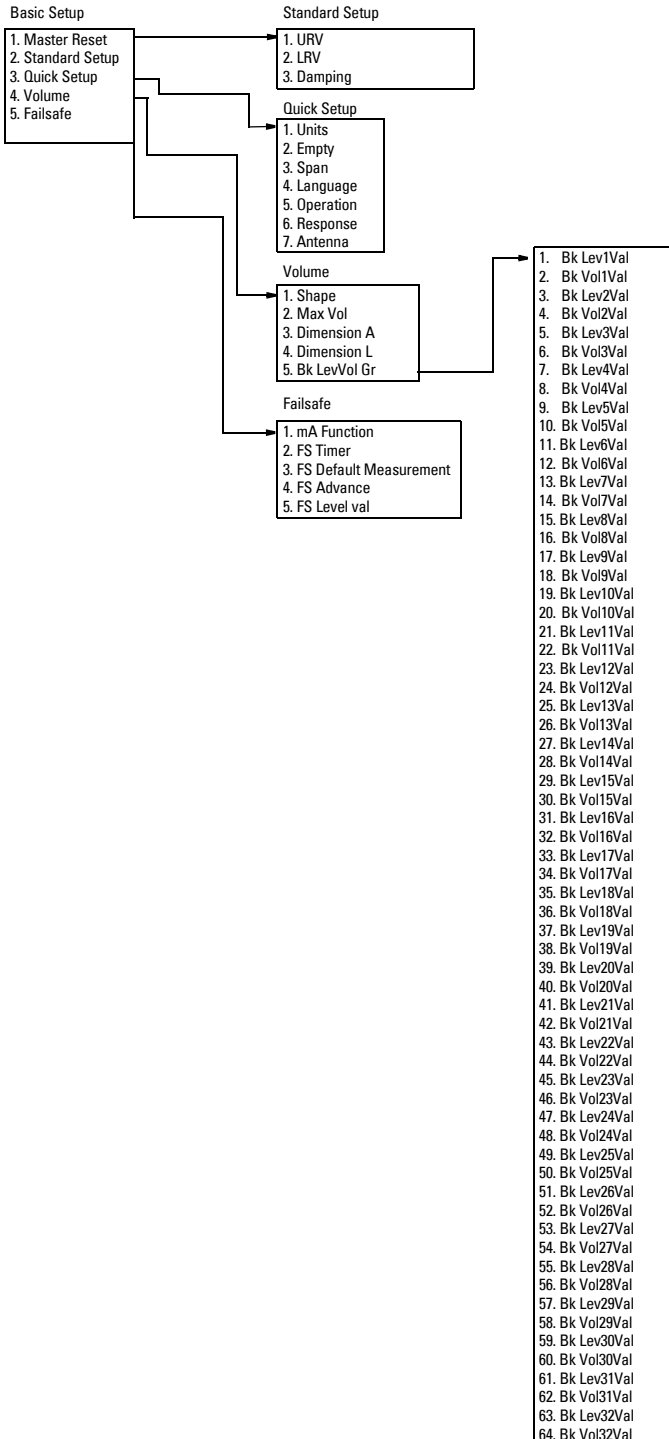

Chart 3

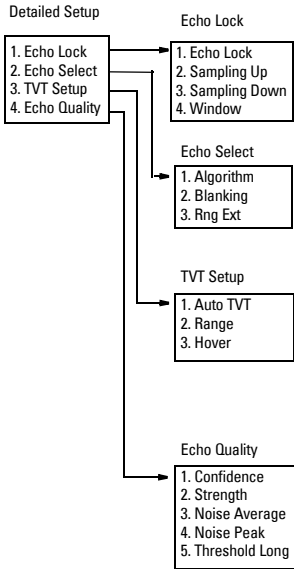
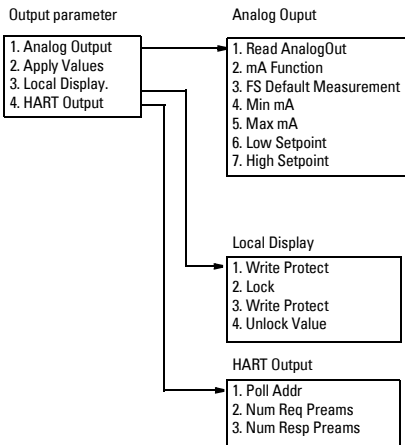

Chart 4



Supported HART Commands:

SITRANS LR 250 conforms to HART rev. 5 and supports the following:

Universal Commands

0, 1, 2, 3, 6, 7, 8, 11, 12, 13, 14, 15, 16, 17, 18, 19, 20, 21, 22

Common Practice Commands

33, 34, 35, 36, 37, 38, 40, 41, 42, 44, 45, 46, 48, 50, 51, 53, 54, 59

Device Specific Commands

Command 150	Read Echo Summary
Command 151	Read Echo Data Profile
Command 162	Read Volume
Command 163	Write Volume
Command 164	Read Volume Breakpoint
Command 165	Write Volume Breakpoint
Command 166	Read Failsafe
Command 167	Write Failsafe
Command 170	Read Echo Lock
Command 171	Write Echo Lock
Command 172	Read TVT
Command 173	Write TVT
Command 174	Read TVT Shaper
Command 175	Write TVT Shaper
Command 178	Read Analog Special
Command 179	Write Analog Special
Command 182	Read Range Calibration
Command 183	Write Range Calibration
Command 186	Read Wear
Command 206	Read Confidence
Command 207	Write Confidence Threshold
Command 208	Read Local Display Commands
Command 209	Write Local Display Commands

Universal and Common Practice Commands

For details on the Universal and Common Practice Commands, please contact the HART Communication Foundation.

Device Specific Commands

For a document containing the Device Specific Commands, please contact Siemens Milltronics at techpubs.smpi@siemens.com.

Appendix L: Software Revision History

Software Rev.	DD Rev.	Date	Changes
			<ul style="list-style-type: none"><li data-bbox="412 277 575 302">• Initial release

Glossary

accuracy: degree of conformity of a measure to a standard or a true value.

agitator: mechanical apparatus for mixing or aerating. A device for creating turbulence.

algorithm: a prescribed set of well-defined rules or processes for the solution of a problem in a finite number of steps.

ambient temperature: the temperature of the surrounding air that comes in contact with the enclosure of the device.

antenna: an aerial which sends out and receives a signal in a specific direction. There are four basic types of antenna in radar level measurement, horn, parabolic, rod, and waveguide.

attenuation: a term used to denote a decrease in signal magnitude in transmission from one point to another. Attenuation may be expressed as a scalar ratio of the input magnitude to the output magnitude or in decibels.

Auto False-Echo Suppression: a technique used to adjust the level of a TVT curve to avoid the reading of false echoes. (See TVT.)

Auto False-Echo Suppression Distance: defines the endpoint of the TVT distance. (See TVT.) This is used in conjunction with auto false echo suppression.

beam width: the angle diametrically subtended by the one-half power limits (-3 dB) of the microwave beam.

beam spreading: the divergence of a beam as it travels through a medium.

blanking: a blind zone extending away from the reference point plus any additional shield length. The instrument is programmed to ignore this zone.

capacitance: the property of a system of conductors and dielectrics that permits the storage of electricity when potential differences exist between the conductors. Its value is expressed as the ratio of a quantity of electricity to a potential difference, and the unit is a Farad.

confidence: describes the quality of an echo. Higher values represent higher quality. Confidence threshold defines the minimum value.

damping: term applied to the performance of an instrument to denote the manner in which the measurement settles to its steady indication after a change in the value of the level.

dB (decibel): a unit used to measure the amplitude of signals.

derating: to decrease a rating suitable for normal conditions according to guidelines specified for different conditions.

dielectric: a nonconductor of direct electric current.¹

dielectric constant (DK): the ability of a dielectric to store electrical potential energy under the influence of an electric field. Also known as Relative Permittivity. An increase in the dielectric constant is directly proportional to an increase in signal amplitude. The value is usually given relative to a vacuum /dry air: the dielectric constant of air is 1¹.

echo: a signal that has been reflected with sufficient magnitude and delay to be perceived in some manner as a signal distinct from that directly transmitted. Echoes are frequently measured in decibels relative to the directly transmitted signal.

echo confidence: the recognition of the validity of the echo. A measure of echo reliability.

Echo Lock Window: a window centered on an echo in order to locate and display the echo's position and true reading. Echoes outside the window are not immediately processed.

Echo Marker: a marker that points to the processed echo.

Echo Processing: the process by which the radar unit determines echoes.

Echo Strength: describes the strength of the selected echo in dB above 1 μ V rms.

Echo Profile: a graphical display of a processed echo.

false echo: any echo which is not the echo from the desired target. Generally, false echoes are created by vessel obstructions.

frequency: the number of periods occurring per unit time. Frequency may be stated in cycles per second.

hertz (Hz): unit of frequency, one cycle per second. 1 Gigahertz (GHz) is equal to 10⁹ Hz.

HART: Highway Addressable Remote Transducer. An open communication protocol used to address field instruments.

horn antenna: a conical, horn-shaped antenna which focuses microwave signals. The larger the horn diameter, the more focused the radar beam.

inductance: the property of an electric circuit by virtue of which a varying current induces an electromotive force in that circuit or in a neighboring circuit. The unit is a Henry.

microwaves: the term for the electromagnetic frequencies occupying the portion of the radio frequency spectrum from 1 GHz to 300 GHz.

1. Many conductive liquids/electrolytes exhibit dielectric properties; the relative dielectric constant of water is 80.

multiple echoes: secondary echoes that appear as double, triple, or quadruple echoes in the distance from the target echo.

Near Blanking: see Blanking

nozzle: a length of pipe mounted onto a vessel that supports the flange.

parameters: in programming, variables that are given constant values for specific purposes or processes.

polarization: the property of a radiated electromagnetic wave describing the time-varying direction and amplitude of the electric field vector.

polarization error: the error arising from the transmission or reception of an electromagnetic wave having a polarization other than that intended for the system.

propagation factor (pf): where the maximum velocity is 1.0, pf is a value that represents a reduction in propagation velocity as a result of the wave travelling through a pipe or medium.

pulse radar: a radar type that directly measures distance using short microwave pulses. Distance is determined by the return transit time.

radar: radar is an acronym for **RA**dio **D**etection **A**nd **R**anging. A device that radiates electromagnetic waves and utilizes the reflection of such waves from distant objects to determine their existence or position.

range: distance between a transmitter and a target.

range extension: the distance below the zero percent or empty point in a vessel.

relative humidity: the ratio of the actual amount of moisture in the atmosphere to the maximum amount of moisture the atmosphere could hold (which varies depending on the air temperature).

relative permittivity: see dielectric constant.

repeatability: the closeness of agreement among repeated measurements of the same variable under the same conditions.

shot: one transmit pulse or measurement.

speed of light: the speed of electromagnetic waves (including microwave and light) in free space. Light speed is a constant 299, 792, 458 meters per second.

stillpipe: a pipe that is mounted inside a vessel parallel to the vessel wall, and is open to the vessel at the bottom.

stilling-well: see **stillpipe**.

two wire radar: a low-energy radar. Can be loop powered, analog, intrinsically safe 4 to 20 mA, or a digital (BUS) transmitter.

TVT (time varying threshold): a time-varying curve that determines the threshold level above which echoes are determined to be valid.

waveguide antenna: a hollow, metallic tube that transmits a microwave signal to the product target.

A

Abbreviations and Identifications

list 2

activating LR 460 33

address 90

agitator blade detection

avoiding 72

agitators 72

analog output

in Measure mode 110

response rate 106

application example 37

application examples

horizontal tank with volume 59

liquid resin in storage vessel 58

Auto False-Echo Suppression 108

TVT shaper adjustment 56

B

beam spreading 13

blanking (see Near Range) 108

C

cables

requirements 24

cleaning

instructions 104

conduits

requirements 24

D

device description

HART 117

Device Description (DD)

how to update 54

E

echo confidence 107

Echo Lock

explanation 107

emission cone

requirements 13

enclosure

opening 24

rotating 15

F

factory reset

via PDM 55

failsafe timer 111

Fail-safe Timers 107

false echo suppression 108

false echoes

set TVT curve to ignore 108

flange sizes

chart 23

function keys

navigation mode 49

H

HART

device description 117

HART Communications

details 117

hazardous area installations

wiring requirements 25

I

Identifications and Abbreviations

list 2

installation

hazardous area requirements 25

requirements 11

internal temperature

monitoring 111

L

Level application example 37

level trend viewing

yT diagram in PDM 56

lid-lock set screw 24

locking ring 15, 24

loop voltage vs. loop resistance

power supply requirements 26

loss of echo

definition 107

M

mA output in Measure mode 110

maintenance

cleaning 104

maintenance settings 81

material mixers 72

Measurement Response

explanation 106

mounting (standard)

horn antennas 14

shielded rod 14

N

Near Range (blanking) 108

O

operating principles 105

P

parameter reset

factory reset via PDM 55

parameter settings

adjust via PDM 52

PDM

see SIMATIC PDM 52

pipe sizes 23

power source

requirements 24

power supply requirements

loop voltage vs. loop resistance 26

process temperature

maximum 111

PROFIBUS address 90

programming chart 95

Programming SITRANS LR 460 34

Q

Quick Start (PDM)

helpful hints 40

launching 39

Quick Start Wizard

via handheld programmer 35

via SIMATIC PDM 38

R

receiver signal 106

reset parameters

via PDM 55

S

settings

adjust parameters via PDM 52

SIMATIC PDM

overview 52

Quick Start 39

Rev. 6.0, SP2 features 52

SITRANS LR 200

overview 4

SITRANS LR250

operating principles 105

stillpipe

weld requirements 16

Support

contact information 2

T

temperature de-Rating

charts 112

temperature specification

Ambient/Operating 12

terminals

accessing 24

troubleshooting

communications 97

operation 101

TVT curve 108

TVT Shaper

manual adjustment via PDM 56

V

vessel shape

conical top 12

parabolic top 12

selection 67

W

welded joints

requirements 16

wiring

cables 24

Y

yT Diagram

level trend viewing 56

LCD menu structure

1. QUICK START

- 1.1 APPLICATION
- 1.2 RESPONSE RATE
- 1.3 SENSOR UNITS
- 1.4 OPERATION
- 1.5 LOW CALIB. PT.
- 1.6 HIGH CALIB. PT.
- 1.7 APPLY?

2. SETUP

- 2.1 DEVICE
 - 2.1.1 LCD CONTRAST
- 2.2 INPUT
 - 2.2.1 SENSOR CALIB.
 - 2.2.1.1 ANTENNA
 - 2.2.1.2 APPLICATION
 - 2.2.1.3 RESPONSE RATE
 - 2.2.1.4 SENSOR UNITS
 - 2.2.1.5 OPERATION
 - 2.2.1.6 LOW CALIB. PT.
 - 2.2.1.7 HIGH CALIB. PT.
 - 2.2.1.11 NEAR RANGE
 - 2.2.1.12 FAR RANGE
 - 2.2.1.13 PROPAG. FACTOR
 - 2.2.1.14 LEVEL OFFSET
 - 2.2.2 VOL CONVERSION
 - 2.2.2.1 VESSEL SHAPE
 - 2.2.3 VOLUME BREAKPT
 - 2.2.3.1 MAX. VOLUME
 - 2.2.3.2 DIMENSION A
 - 2.2.3.3 DIMENSION L
 - 2.2.3.4 TABLE 1 – 8
 - 2.2.3.5 TABLE 9 – 16
 - 2.2.3.6 TABLE 17 – 24
 - 2.2.3.7 TABLE 25 – 32
 - 2.2.4 ECHO PROC.
 - 2.2.4.1 ECHO SELECT
 - 2.2.4.1.1 ALGORITHM
 - 2.2.4.1.2 POSITION
 - 2.2.4.1.3 ECHO THRESHOLD
 - 2.2.4.2 SAMPLING
 - 2.2.4.2.1 ECHO LOCK
 - 2.2.4.2.4 SAMPLING UP
 - 2.2.4.2.5 SAMPLING DOWN
 - 2.2.4.2.6 WINDOW

- 2.2.4.3 FILTERING
 - 2.2.4.3.2 DAMPING FILTER
- 2.2.4.4 TANK BOTTOM ALG
 - 2.2.4.4.3 CLEF RANGE
- 2.2.4.5 NOISE
 - 2.2.4.5.1 CONFIDENCE
 - 2.2.4.5.2 STRENGTH
 - 2.2.4.5.3 NOISE AVERAGE
- 2.2.5 TVT SETUP
 - 2.2.5.1 TVT HOVER LEVEL
 - 2.2.5.6 AUTO ECHO SUPP
 - 2.2.5.7 AUTO SUPP RANGE
 - 2.2.5.8 SHAPER MODE
- 2.2.6 TVT SHAPER
 - 2.2.6.1 SHAPER 1-9
 - 2.2.6.2 SHAPER 10-18
 - 2.2.6.3 SHAPER 19-27
 - 2.2.6.4 SHAPER 28-36
 - 2.2.6.5 SHAPER 37-40
- 2.2.7 RATE
 - 2.2.7.1 RESPONSE RATE
 - 2.2.7.2 FILL RATE
 - 2.2.7.3 EMPTY RATE
- 2.2.8 TB VALUES
 - 2.2.8.1 READING MEAS.
 - 2.2.8.2 MATERIAL MEAS.
 - 2.2.8.3 SPACE MEAS.
 - 2.2.8.4 DISTANCE MEAS.
 - 2.2.8.5 VOLUME MEAS.
 - 2.2.8.7 SENSOR VALUE
- 2.3 OUTPUT
 - 2.3.1 MA OUTPUT
 - 2.3.1.1 MA OUTPUT VALUE
 - 2.3.1.2 MA OUTPUT FUNC.
 - 2.3.1.3 4 MA SETPOINT
 - 2.3.1.4 20 MA SETPOINT
 - 2.3.1.5 MIN. MA LIMIT
 - 2.3.1.6 MAX. MA LIMIT
 - 2.3.1.7 4 MA OUTPUT TRIM
 - 2.3.1.8 20 MA OUTPUT TRIM
- 2.4 FAIL-SAFE
 - 2.4.1 FAILSAFE TIMERS
 - 2.4.2 FAILSAFE MAT. LEVEL
 - 2.4.4 FAILSAFE LEVEL
- 3. DIAGNOSTICS**
 - 3.1 ECHO PROFILE
 - 3.14 MEAS. VALUES
 - 3.14.1 CURR. INTERN. TEMP.
 - 3.14.2 MAX. INTERN. TEMP.
 - 3.14.3 MIN. INTERN. TEMP.

- 3.15 REMAIN. DEV. LIFE
 - 3.15.1 TOTAL OP--TIME
 - 3.15.2 REMAIN. LIFETIME
 - 3.15.3 MAINT REQ LIMIT
 - 3.15.4 MAINT DEM LIMIT
 - 3.15.5 ALERT ACTIVATION
 - 3.15.6 TOTAL EXP. LIFE
 - 3.15.7 MAINT STAT
 - 3.15.8 ACK STATUS
 - 3.15.9 ACK
- 3.16 REMAIN. SENS. LIFE
 - 3.16.1 SENS OP--TIME
 - 3.16.2 REMAIN. LIFETIME
 - 3.16.3 MAINT REQ LIMIT
 - 3.16.4 MAINT DEM LIMIT
 - 3.16.5 ALERT ACTIVATION
 - 3.16.6 TOTAL EXP. LIFE
 - 3.16.7 MAINT STAT
 - 3.16.8 ACK STATUS
 - 3.16.9 ACK

4. SERVICE

- 4.1 FACTORY RESET
- 4.2 POWERED HOURS
- 4.4 POWERON RESETS
- 4.7 MANUF. DATE
- 4.8 SOFTWARE REV
- 4.9 LOADER REV
- 4.11 HARDWARE REV
- 4.12 MEM. TEST
- 4.17 SERVICE INTERVAL
 - 4.17.1 TIME LAST SERV
 - 4.17.2 MAINT REQ LIMIT
 - 4.17.3 MAINT DEM LIMIT
 - 4.17.4 ALERT ACTIVATION
 - 4.17.5 SERVICE INTERVAL
 - 4.17.6 MAINT STAT
 - 4.17.7 ACK STATUS
 - 4.17.8 ACK
- 4.18 CALIB. INTERVAL
 - 4.18.1 TIME LAST CAL.
 - 4.18.2 MAINT REQ LIMIT
 - 4.18.3 MAINT DEM LIMIT
 - 4.18.4 ALERT ACTIVATION
 - 4.18.5 TOTAL CALIB.INTRV
 - 4.18.6 MAINT STAT
 - 4.18.7 ACK STATUS
 - 4.18.8 ACK

- 5. COMMUNICATION**
 - 5.1 DEVICE ADDRESS
 - 5.2 COMM. CONTROL
- 6. SECURITY**
 - 6.1 LOCK
 - 6.2 UNLOCK VALUE
- 7. LANGUAGE**