







Parameter reference

Note

- See **Enter PROGRAM** mode under LCD Display (Page 57) for detailed instructions.
 - To view a particular parameter in AMS, see Operating via AMS Device Manager (Page 79).
 - Do not use the handheld programmer at the same time as AMS Device Manager, or erratic operation may result.
 - For Quick Access to parameters via the handheld programmer, press **Home** , then enter the menu number, for example: **2.2.1.** to access parameter **Hardware Revision (2.2.1.)**.
 - In Navigation mode, **ARROW keys** (   ) navigate the menu in the direction of the arrow.
 - Press **RIGHT arrow**  to open **Edit Mode**, or to save a modification.
-

Parameters are identified by name and organized into function groups. Menus arranged on up to four levels give access to associated features and options. See LCD menu structure (Page 296) for a chart.

Parameters noted as **Read Only** in this section of the manual can not be written via the LUI, however they may be accessible via other tools. For those accessible via AMS Device Manager, directions are shown in section **Operating via AMS Device Manager** on the pages referenced.

Quick Start Wizard

The Quick Start Wizard groups together all the settings you need to configure a device for a simple application. You can access it either via AMS Device Manager or via the handheld programmer.

- Do not use the Quick Start Wizard via the handheld programmer to modify individual parameters. (Perform customization only after the Quick Start has been completed.)
- Each time the Quick Start Wizard is initiated via the handheld programmer, the startup settings are factory defaults. The Wizard will not recall previous user-defined settings. (Note: Values set using the Quick Start Wizard via AMS Device Manager are saved and recalled each time it is initiated.)
- When using AMS Device Manager, the Resource and LTB Blocks must be set to Out of Service mode before any configuration changes (changes to parameters affecting block output) can be written. The blocks do not need to be set to Out of Service when the Quick Start Wizard is initiated via the handheld programmer.

Quick Start (1.)

Note

For detailed instructions see Quick Start Wizard via the handheld programmer (Page 65) or Quick Start Wizard via AMS Device Manager (Page 85).

Setup (2.)

Note

- See Parameter menus (Page 60) or Operating via AMS Device Manager (Page 79) for instructions.
 - Default settings in the parameter tables are indicated with an asterisk (*) unless explicitly stated.
 - Values shown in the following tables can be entered via the handheld programmer.
-

Identification (2.1.)

Tag (2.1.1.)

Read only. Text that can be used in any way. A recommended use is as a unique label for a field device in a plant. Limited to 32 ASCII characters.

Note

The tag can only be changed from a remote master such as NIFBUS-Configurator or DeltaV.

Descriptor (2.1.2.)

Read only. Text that can be used in any way. Limited to 32 ASCII characters. No specific recommended use.

To access this parameter via AMS Device Manager see **Identification** under Identification (RESOURCE) (Page 111).

Message (2.1.3.)

Read only. Text that can be used in any way. Limited to 32 ASCII characters. No specific recommended use.

To access this parameter via AMS Device Manager see Identification under Identification (RESOURCE). (Page 111)

Device (2.2.)**Hardware Revision (2.2.1.)**

Read only. Corresponds to the electronics hardware of the Field Device.

Firmware Revision (2.2.2.)

Read only. Corresponds to the software or firmware that is embedded in the Field Device.

Loader Revision (2.2.3.)

Read only. Corresponds to the software used to update the Field Device.

Sensor (2.3.)**Unit (2.3.1)**

Sensor measurement unit.

Values		m, cm, mm, ft, in
	*	m

Level Unit (2.3.2.)

Select engineering units for Level.

Options		m, cm, mm, ft, in, %
	*	%

PV Units (volume/level) (2.3.3.)

Note

- Default unit of AIFB 1 or 2 is percent.
- You can select a different unit for your application.
- PV (Primary Value): the output from the Level Transducer Block. See **Level Transducer Block (LTB)** and **How the LTB works:** in manual *Foundation Fieldbus for Level Instruments* (TML19985MP01) for more details.

Select units for either volume or level.

Level values		m, cm, mm, ft, in, %
Volume values		liter, gal, ImpGal, %
Percent value	*	%

Temperature Units (2.3.4.)

Selects the engineering unit to be displayed with the value representing temperature.

Options		DEGC, DEGF, DEGR, K
	*	DEGC

Material (2.3.5.)

Automatically configures the device to operate in the chosen application type, by changing one or more of the following parameters: **Propagation Factor (2.5.3.)**, **Position Detect (2.5.7.2.)**, and/or **CLEF Range (2.5.7.4.)**.

Options	*	LIQUID
		LIQUID LOW DK ^{a)} (low dielectric liquid - CLEF algorithm enabled)
Related parameters	Propagation Factor (2.5.3.) Position Detect (2.5.7.2.) CLEF Range (2.5.7.4.)	

^{a)} dK < 3.0

You can configure each of the related parameters, to suit your particular application.

LOE Timer (2.3.6.)

Note

See Loss of Echo (LOE) (Page 274) for more detail.

Sets the time to elapse since the last valid reading, before the Fail-safe material level is reported.

Values	Range: 0 to 7200 seconds
	Default: 100 s

Calibration (2.3.7)

Low Calibration Pt. (2.3.7.1.)

Distance from sensor reference point to Low Calibration Point (corresponding to Low Level Point). Units are defined in **Unit (2.3.1.)**.

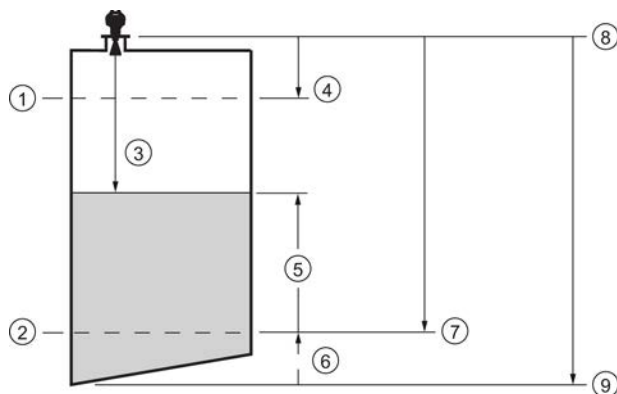

- ① High level point (default 100%)
- ② Low level point (0%)
- ③ Sensor value
- ④ High calibration point
- ⑤ Level
- ⑥ Level offset (if used)
- ⑦ Low calibration point
- ⑧ Sensor reference point ^{a)}
- ⑨ Far range

^{a)} The point from which level measurement is referenced [see Flat Faced Flange (Page 258) and Threaded Horn Antenna with extension (Page 221) and Flanged encapsulated antenna (3"/DN80/80A sizes and larger). (Page 232)].

Values	Range: 0.00 to 20.00 m. Default 20.00 m
Related parameters	Unit (2.3.1.) Far Range (2.5.2.)

High Calibration Point (2.3.7.2.)

Distance from sensor reference point ¹⁾ to High Calibration Point (corresponding to High Level Point). Units are defined in **Unit (2.3.1.)**. See **Low Calibration Point (2.3.7.1.)** for an illustration.

Values	Range: 0.00 to 20.00 m. Default 0.00 m
Related parameters	Unit (2.3.1.), Near Range (2.5.1.)

When setting the High Calibration Point value, note that echoes are ignored within **Near Range (2.5.1.)**.

¹⁾ The value produced by the echo processing which represents the distance from sensor reference point to the target. [see Threaded Horn Antenna with extension, (Page 224) Flanged Horn with extension (Page 228), and Flanged encapsulated antenna (3"/DN80/80A sizes and larger) (Page 232)].

Sensor Offset (2.3.7.3.)

A constant offset that can be added to or subtracted from the sensor value to compensate for a shifted sensor reference point. (For example, when adding a thicker gasket or reducing the standoff/nozzle height.) The units are defined in **Unit (2.3.1.)**.

Values	Range: -99.999 to 99.999 Default: 0.000 m
Related Parameters	Unit (2.3.1.)

See **How the LTB works**: in manual *Foundation Fieldbus for Level Instruments (7ML19985MP01)* for more details on sensor offset.

Low Level Point (2.3.7.4.)

The level when the material is at Low Calibration Point. The unit is defined in **Level Unit (2.3.2.)**.

Values	Range: -999999 to 999999
	Default: 0%

High Level Point (2.3.7.5.)

The level when the material is at High Calibration Point. The unit is defined in **Level Unit (2.3.2.)**.

Values	Range: -999999 to +999999
	Default: 100%

Level Offset (2.3.7.6.)

A constant offset that can be added to Level. The unit is defined in **Level Unit (2.3.2.)**.

Values	Range: -999999 to +999999
	Default: 0%

Rate (2.3.8.)**Response Rate (2.3.8.1.)**

Sets the reaction speed of the device to measurement changes.

Note

Changing Response Rate resets **Fill Rate per Minute (2.3.8.2)**, **Empty rate per Minute (2.3.8.3)**, and **Shots (2.5.6.)**.

Response Rate (2.3.8.1.)		Fill Rate per Minute (2.3.8.2.)/ Empty rate per Minute (2.3.8.3.)	Shots (2.5.6.)
*	Slow	0.1 m/min (0.32 ft/min)	25
	Medium	1.0 m/min (3.28 ft/min)	10
	Fast	10.0 m/min (32.8 ft/min)	5

Use a setting just faster than the maximum filling or emptying rate (whichever is faster).

Fill Rate per Minute (2.3.8.2.)

Defines the maximum rate at which the reported sensor value is allowed to decrease. Allows you to adjust the SITRANS LR250 response to decreases in the actual material level. Fill Rate is automatically updated whenever **Response Rate (2.3.8.1.)** is altered.

Sensor value is the value produced by the echo processing which represents the distance from sensor reference point to the target [see **Low Calibration Point (2.3.7.1.)** for an illustration].

Options	Range: 0 to 999999 m / min.	
	Response Rate (2.3.8.1.)	
	Fill Rate per Minute (2.3.8.2.)	
	*	Slow
	Medium	1.0 m/min (3.28 ft/min)
	Fast	10.0 m/min (32.8 ft/min)
Altered by:	Response Rate (2.3.8.1.)	
Related parameters	Level Unit (2.3.2.)	

Enter a value slightly greater than the maximum vessel-filling rate, in units per minute.

Empty Rate per Minute (2.3.8.3)

Defines the maximum rate at which the reported sensor value is allowed to increase. Adjusts the SITRANS LR250 response to increases in the actual material level. Empty Rate is automatically updated whenever Response Rate is altered.

The sensor value is the value produced by the echo processing which represents the distance from sensor reference point to the target [see **Low Calibration Point (2.3.7.1.)** for an illustration].

Options	Range: 0 to 99999 m / min.	
	Response Rate (2.3.8.1.)	Empty Rate
	* Slow	0.1 m/min (0.32 ft/min)
	Medium	1.0 m/min (3.28 ft/min)
	Fast	10.0 m/min (32.8 ft/min)
Altered by:	Response Rate (2.3.8.1)	
Related parameters	Level Unit (2.3.2.)	

Enter a value slightly greater than the vessel's maximum emptying rate, in units per minute.

Linearization (2.4.)

Volume (2.4.1.)

Carries out a volume conversion from a level value.

Vessel Shape (2.4.1.1.)

Defines the vessel shape and allows the LR250 to calculate volume instead of level. If **None** is selected, no volume conversion is performed. Select the vessel shape matching the monitored vessel or reservoir.

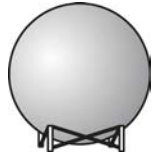
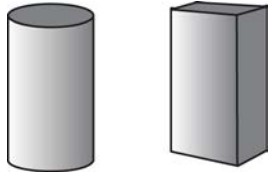
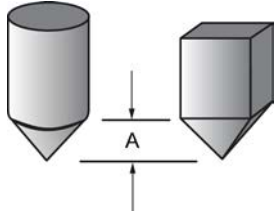
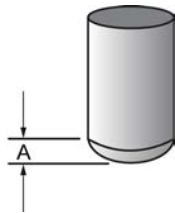
	Vessel Shape	LCD DISPLAY/ Description	Also required
*	None	NONE/ No volume calculation required	N/A
		CYLINDER/ Flat end horizontal cylinder	Maximum volume
		SPHERE/ Sphere	Maximum volume
		LINEAR/ Upright, linear (flat bottom)	Maximum volume
		CONICAL BOT/ Conical or pyramidal bottom	Maximum volume, dimension A
		PARABOLIC BOT/Parabolic bottom	Maximum volume, dimension A

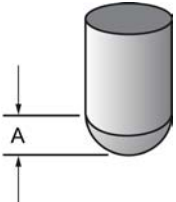
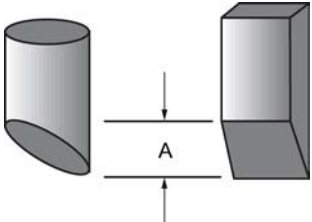
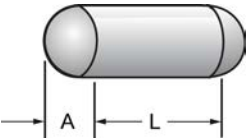
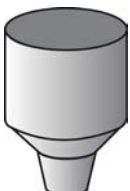
	Vessel Shape	LCD DISPLAY/ Description	Also required
		HALF SPHERE BOT/ Half-sphere bottom	Maximum volume, dimension A
		FLAT SLOPED BOT/ Flat sloped bottom	Maximum volume, dimension A
		PARABOLIC ENDS/ Parabolic end horizontal cylinder	Maximum volume, dimension A, dimension L
		LINEAR TABLE ^{a)} / Linearization table (level/volume breakpoints)	Maximum volume, level breakpoints, volume breakpoints

a) Linearization Table must be selected in order for level/volume values [see **XY index (2.4.1.5.)**] to be transferred.

Maximum Volume (2.4.1.2.)

The maximum volume of the vessel. Units are defined in **PV Units (volume/ level) (2.3.3.)**. Enter the vessel volume corresponding to High Calibration Point. The volume calculation is based on the maximum volume and scaled according to the vessel shape selected. If no vessel shape is entered, the default is 100, and the reading will be a percentage value.

Values	Range: 0.0000 to 999999
	Default: 100.0
Related Parameters	Low Calibration Pt. (2.3.7.1.) High Calibration Pt. (2.3.7.2.) Vessel Shape (2.4.1.1.)

For readings in volumetric units instead of percentage values:

1. Select a volumetric unit from **PV Units (volume/level) (2.3.3.)**.
2. Enter the vessel volume corresponding to High Calibration Point.

Vessel Dimension A (2.4.1.3.)

The height of the vessel bottom in Level Units when the bottom is conical, pyramidal, parabolic, spherical, or flat -sloped. If the vessel is horizontal with parabolic ends, the depth of the end. See **Vessel Shape (2.4.1.1.)** for an illustration.

Values	Range: 0.0000 to 999999 in Level Units
	Default: 0.0
Related Parameters	Vessel Shape (2.4.1.1.)

Dimension L (2.4.1.4.)

Length of the cylindrical section of a horizontal parabolic end vessel, in Level Units. See **Vessel Shape (2.4.1.1.)** for an illustration.

Values	Range: 0.0000 to 999999 in Level Units
	Default: 0.0
Related Parameters	Vessel Shape (2.4.1.1.)

XY index (2.4.1.5.)

Level/Volume breakpoints allow you to define a complex vessel shape as a series of segments. A value is assigned to each level breakpoint and a corresponding value is assigned to each volume breakpoint.

Volume values are defined in volume units and can be percent or volumetric; level values are defined in level units, and can be percent or linear.

Level values	Range: 0.0000 to 999999 (m, cm, mm, ft, in, %)
	Default: 0.0
Volume values	Range: 0.0000 to 999999 (% or volumetric units)
	Default: 0.0

Enter up to 32 level breakpoints, where the corresponding volume is known. The values corresponding to 100% and 0% levels must be entered. The breakpoints can be ordered from top to bottom, or the reverse.

Example (values are for example purposes only)

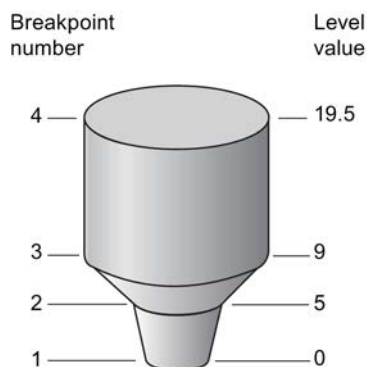

Breakpoint Number	Level value (m)	Volume value (l)
1	0	0
2	5	500
3	9	3000
4	19.5	8000

Entering breakpoints via the hand-held programmer:

1. The default for level values is percent: if you want to select units instead, navigate to **Setup (2.) > Sensor (2.3.) > Level Unit (2.3.2.)**, and select the desired unit.
2. Navigate to **Setup (2.) > Sensor (2.3.) > PV Units (volume/level) (2.3.3.)**, and select the desired volume units.
3. Go to **XY index (2.4.1.5.)** and enter the number of the breakpoint you wish to adjust: for example, for breakpoint 1 enter 1.
4. Go to **X value (2.4.1.6.)** and enter the level value for the breakpoint just identified.
5. Go to **Y value (2.4.1.7.)** and enter the volume value for the breakpoint just identified.
6. Repeat steps 3 to 5 until values have been entered for all required breakpoints.

X value (2.4.1.6.)

See **XY Index (2.4.1.5.)**.

Y value (2.4.1.7.)

See **XY Index (2.4.1.5.)**.

Entering breakpoints via AMS: See Linearization (LTB) (Page 97)

After completing the above steps you will need to configure AIFB 1 and/or AIFB 2. [See **AIFB 1 (2.6.)** and **AIFB 2 (2.7.)** for details.]

Signal Processing (2.5.)

In AMS Device Manager, see the General tab under Signal Processing (LTB) (Page 99).

Near Range (2.5.1.)

The range in front of the device (measured from the sensor reference point within which any echoes will be ignored. (This is sometimes referred to as "Blanking" or "Dead Zone".) The factory setting is 50 mm (2") past the end of the antenna, and the range is dependent on the antenna type and process connection. [See Threaded Horn Antenna with extension (Page 221) and Flanged Horn (Page 226) for antenna heights to sensor reference point.]

Values	Range: 0 to 20 m (0 to 65.6 ft)				
	Default depends on antenna type and process connection.				
	Examples:	<table border="1"> <tr> <td>1.5" threaded horn</td> <td>185.3 mm (7.3")</td> </tr> <tr> <td>4" horn with stainless steel flange and 100 mm (4") extension</td> <td>373.3 mm (14.7")</td> </tr> </table>	1.5" threaded horn	185.3 mm (7.3")	4" horn with stainless steel flange and 100 mm (4") extension
1.5" threaded horn	185.3 mm (7.3")				
4" horn with stainless steel flange and 100 mm (4") extension	373.3 mm (14.7")				
Related parameters	Unit (2.2.1.)				

Far Range (2.5.2.)

Note

Far Range can extend beyond the bottom of the vessel.

Allows the material level to drop below Low Calibration Point without generating a Loss of Echo (LOE) state. See **Low Calibration Pt. (2.3.7.1.)** for an illustration.

Values	Range: Min. = Low Calibration Pt. Max. = 33 m (108.27 ft) Default: Value for Low Calibration Pt. + 1 m (3.28 ft)
Related parameters	Unit (2.3.1.) CLEF (Constrained Leading Edge Fit) Range (2.5.7.4.) ^{a)}

^{a)} The value set for Far Range becomes the CLEF Range maximum. If the value for Far Range is changed after a CLEF Range value is entered, CLEF Range is reset to its default (0.00 m).

Use this feature if the measured surface can drop below the Low calibration point in normal operation.

Propogation Factor (2.5.3.)

Note

- When operating in a stillpipe, values for **CLEF Range (2.5.7.4.)**, and for the Propagation Factor, should be set according to the pipe size. See the table below.
 - For reliable results the antenna size must be close to the pipe size.
-

Compensates for the change in microwave velocity due to propagation within a metal stillpipe instead of in free space.

Values	Range:	0.3 to 1.0 depending on pipe size.		
	Default:	1.0000		
Nominal Pipe Size^{a)}	40 mm (1.5")	50 mm (2")	80 mm (3")	100 mm (4")
Propagation Factor	0.9844	0.988	0.9935	0.9965
CLEF Range (2.5.7.4.)	Low calibration point - 700 mm (2.29 ft) ^{b)}	Low calibration point - 700 mm (2.29 ft) ^{b)}	Low calibration point - 1000 mm (3.28 ft) ^{b)}	Low calibration point - 1000 mm (3.28 ft) ^{b)}

a) Since pipe dimensions may vary slightly, the propagation factor may also vary.

b) CLEF range covers the whole measurement range except first 700 or 1000 mm from unit reference point (see A in graphic below)

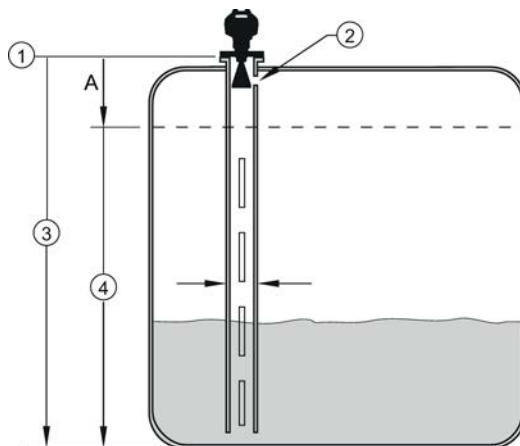

① sensor reference point

② air gap

A 700 or 1000 mm

③ low calibration point

④ CLEF range 2.5.7.4.

Note

Flanged encapsulated antenna

For Flanged encapsulated antenna (7ML5432) match the process connection size to the pipe diameter whenever possible (for example, mount a DN80/3" flange on DN80/3" pipe).

Minimum Sensor Value (2.5.4.)

The minimum usable value for the measuring range, in units defined in **Unit (2.3.1.)**. (Default = 0.0 m)

To view this parameter via AMS Device Manager see **Range** under Signal Processing (LTB) (Page 99).

Maximum Sensor Value (2.5.5.)

The maximum usable value for the measuring range, in units defined in **Unit (2.3.1.)**. (Default = 33.0 m)

To view this parameter via AMS Device Manager see **Range** under Signal Processing (LTB) (Page 99).

Shots (2.5.6.)

The number of echo profile samples averaged to produce a measurement.

Values	Range: 1 to 25
	Default: 25 ^{a)}

^{a)} To meet accuracy specification, the number of shots must be set to 25 [see Performance (Page 213)].

Echo Select (2.5.7.)

Algorithm (2.5.7.1.)

Selects the algorithm to be applied to the echo profile to extract the true echo.

Options	*	tF	True First echo
		F	First echo
		L	Largest echo
		BLF	Best of Largest and First echo

Position Detect (2.5.7.2.)

Defines where on the echo the distance measurement is determined.

Options		Center
	*	Hybrid (Center and CLEF)
		CLEF (Constrained Leading Edge Fit)
Related parameters	CLEF Range (2.5.7.4.)	

If the vessel bottom is being reported as the level instead of the actual material level (at low level conditions), or if the dielectric constant of the liquid to be monitored is less than 3, we recommend setting Position Detect to **Hybrid** and **CLEF (Constrained Leading Edge Fit) Range (2.5.7.4.)** to 0.5 m (1.64 ft).

Echo Threshold (2.5.7.3.)

Sets the minimum echo confidence that the echo must meet in order to prevent a Loss of Echo condition and the expiration of the Fail-safe (LOE) timer. When **Confidence (2.5.9.1.)** exceeds **Echo Threshold (2.5.7.3.)**, the echo is accepted as a valid echo and is evaluated.

Values	Range: 0 to 99
	Default: 5
Related Parameters	Loss of Echo (LOE) Timer (2.3.6.) Confidence (2.5.9.1.)

Use this feature when an incorrect material level is reported.

CLEF Range (2.5.7.4.)**Note**

CLEF Range is referenced from Low Calibration Point (process empty level).

The CLEF algorithm is used mainly to allow correct level reporting for low dK materials which may otherwise cause an incorrect reading in an empty or almost empty vessel.

It is used from Low Calibration Point (process empty level) up to the level defined by CLEF Range (see illustration below). Above that point the Center algorithm is used. For more detail see CLEF Range (Page 269).

Values	Range: 0 to 20 m (0 to 65.6 ft)
	Default: 0.0 m
Related parameters	Position Detect (2.5.7.2.)

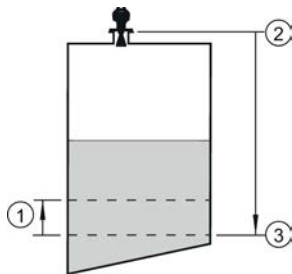

- ① CLEF Range
- ② Sensor reference point
- ③ Low calibration point (process empty level)

In applications with low dK materials we recommend setting CLEF Range to 0.5 m (1.64 ft) and **Position Detect (2.5.7.2.)** to Hybrid.

Sampling (2.5.8.)

Provides a method of checking the reliability of a new echo before accepting it as the valid reading, based on numbers of samples above or below the currently selected echo.

Echo Lock (2.5.8.1.)

Note

Ensure the agitator is always running while SITRANS LR250 is monitoring the vessel, to avoid stationary blade detection.

Selects the measurement verification process. See **Echo Lock (2.5.8.1.)** for more details.

Options		Lock Off (no verification)
		Maximum Verification
	*	Material Agitator
		Total Lock
Related parameters	Fill Rate per Minute (2.3.8.2.) Empty Rate per Minute (2.3.8.3.) Up Sampling (2.5.8.2.) Down Sampling (2.5.8.3.)	

For radar applications, Material Agitator is the most often-used setting, to avoid agitator blade detection.

Sampling Up (2.5.8.2.)

Specifies the number of consecutive echoes that must appear above the echo currently selected, before the measurement is accepted as valid.

Values	Range: 1 to 50
	Default: 5

Down Sampling (2.5.8.3.)

Specifies the number of consecutive echoes that must appear below the echo currently selected, before the measurement is accepted as valid.

Values	Range: 1 to 50
	Default: 2 (see Related parameters)
Related parameters	Echo Lock (2.5.8.1.) If Echo Lock set to any value other than its default (2), then Down Sampling default = 5.

Echo Quality (2.5.9.)**Confidence (2.5.9.1.)**

Indicates echo reliability: higher values represent better echo quality. The display shows the echo confidence of the last measurement. **Echo Threshold (2.5.7.3.)** defines the minimum criterion for echo confidence.

Values (view only)	0 to 99
	Echo Threshold (2.5.7.3.)
Related Parameters	

Open the menu **Device – Echo Profile Utilities** and click on the tab **Echo Profile**.

Echo Strength (2.5.9.2.)

Displays the absolute strength (in dB above 1 μ V rms) of the echo selected as the measurement echo.

Values (view only)	Range: -20 to 99
---------------------------	-------------------------

TVT (Auto False Echo Suppression) Setup (2.5.10.)

Note

- Make sure material level is below all known obstructions when Auto False Echo Suppression is used to learn the echo profile. (An empty or almost empty vessel is recommended.)
 - Note the distance to material level when Auto False Echo learns the environment. Set Auto False Echo Suppression Range to a shorter distance to avoid the material echo being screened out.
 - Set Auto False Echo Suppression and Auto False Echo Suppression Range during startup, if possible.
 - If the vessel contains an agitator it should be running.
 - Before adjusting these parameters, rotate the instrument for best signal (lower false-echo amplitude).
-

Auto False Echo Suppression (2.5.10.1.)

Used together with **Auto False Echo Suppression Range (2.5.10.2.)** to screen out false echoes in a vessel with known obstructions. A 'learned TVT' (time varying threshold) replaces the default TVT over a specified range. See Auto False Echo Suppression (Page 271) for a more detailed explanation.

Before Auto False Echo Suppression

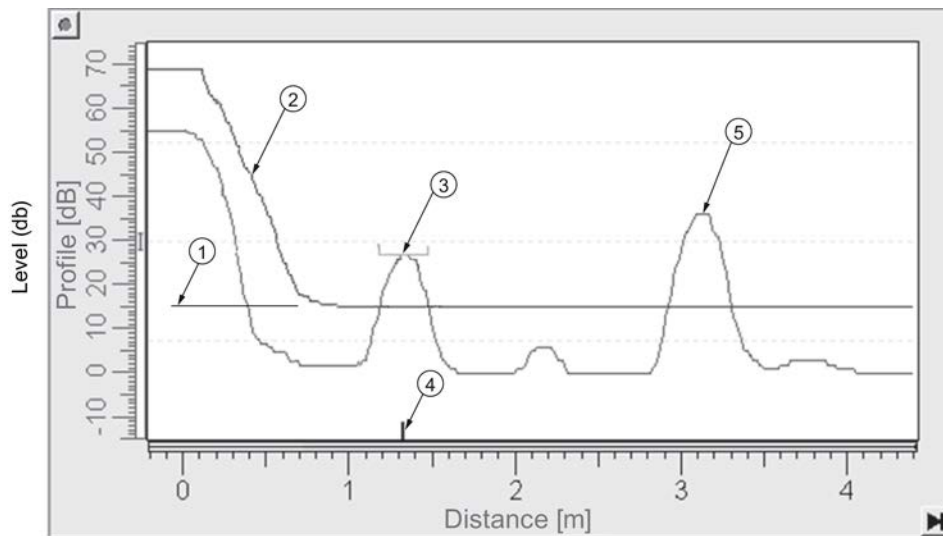

- | | |
|-------------------|------------------|
| ① TVT Hover Level | ④ echo marker |
| ② default TVT | ⑤ material level |
| ③ false echo | |

1. Determine Auto False Echo Suppression Range. Measure the actual distance from the sensor reference point to the material surface using a rope or tape measure.
2. Subtract 0.5 m (20") from this distance, and use the resulting value.

After Auto False Echo Suppression

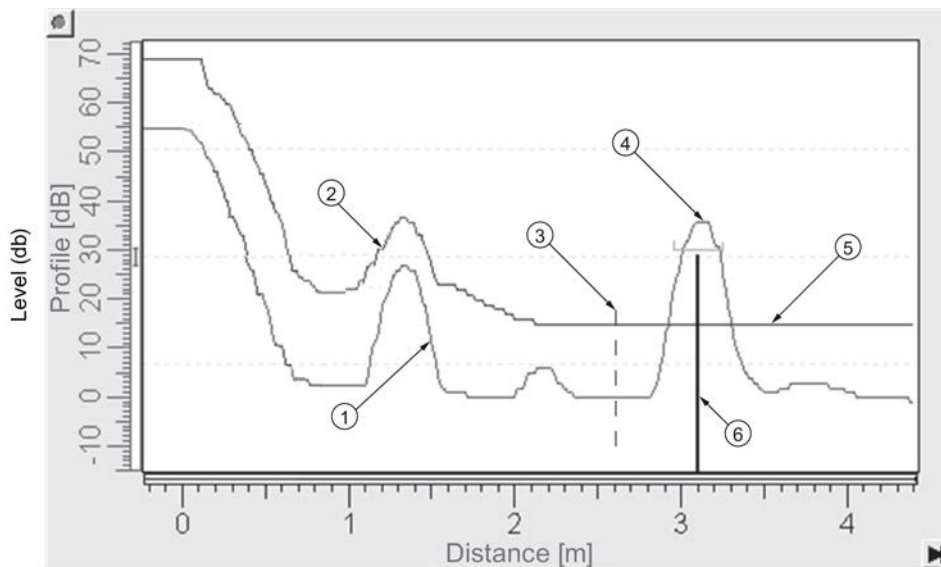

- ① false echo
- ② learned TVT
- ③ Auto False Echo Suppression Range
- ④ material level
- ⑤ default TVT
- ⑥ echo marker

To use Auto False Echo Suppression via AMS Device Manager note value calculated in step 1 and see Auto False Echo Suppression (Page 100).

Auto False Echo Suppression Range (2.5.10.2.)

Defines the endpoint of the Learned TVT distance. Units are defined in **Unit (2.3.1.)**.

Values	Range: 0.00 to 30.00 m
	Default: 1.00 m

1. Press **RIGHT arrow** to open Edit mode.
2. Enter the new value and press **RIGHT arrow** to accept it.
3. Set **Auto False Echo Suppression (2.5.10.1.)**.

Hover Level (2.5.10.3.)

Defines how high the TVT (Time Varying Threshold) is placed above the noise floor of the echo profile, as a percentage of the difference between the peak of the largest echo in the profile and the noise floor. See **Auto False Echo Suppression (2.5.10.1)** for an illustration.

Values	Range: 0 to 100%
	Default: 40%

When the device is located in the center of the vessel, the TVT hover level may be lowered to increase the confidence level of the largest echo.

Shaper Mode (2.5.10.4.)

Enables/disables **TVT shaper (2.5.11.)**

Options		ON
	*	OFF

TVT Shaper (2.5.11.)**Note**

- The range is –100 to +100 bits. With 2 bits per dB this gives a range of –50 to +50 dB.
- **Shaper Mode (2.5.10.4.)** must be turned **ON** in order for TVT shaper points to be transferred.

Adjusts the TVT (Time Varying Threshold) at a specified range (breakpoint on the TVT). This allows you to reshape the TVT to avoid unwanted echoes. There are 40 breakpoints arranged in 5 groups. (We recommend using SIMATIC PDM to access this feature.)

To use TVT shaper via LUI (local user interface):

1. Go to **Shaper Mode (2.5.10.4.)** and select **On**.
2. In TVT shaper, go to **Breakpoint 1-9 (2.5.11.1.)**.
3. Open Breakpoint 1 and enter the TVT Offset value (between –50 and 50).
4. Go to the next Breakpoint and repeat step 3 until all desired breakpoint values have been entered.

Breakpoint 1-9 (2.5.11.1.)

Values	Range: -100 to +100 bits (equivalent to - 50 to +50 dB)
	Default: 0 dB

Breakpoint 10-18 (2.5.11.2.)

Values	Range: -100 to +100 bits (equivalent to - 50 to +50 dB)
	Default: 0 dB

Breakpoint 19-27 (2.5.11.3.)

Values	Range: -100 to +100 bits (equivalent to - 50 to +50 dB)
	Default: 0 dB

Breakpoint 28-36 (2.5.11.4.)

Values	Range: -100 to +100 bits (equivalent to - 50 to +50 dB)
	Default: 0 dB

Breakpoint 37-40 (2.5.11.5.)

Values	Range: -100 to +100 bits (equivalent to - 50 to +50 dB)
	Default: 0 dB

To access TVT Shaper via AMS Device Manager see TVT Shaper (Page 100).

AIFB1 (2.6.)**Note**

- Default settings in the parameter tables are indicated with an asterisk (*) unless explicitly stated.
- All AIFB parameters are read only via LUI and AMS Device Manager, and can only be changed using a remote host such as DeltaV or NI-FBUS Configurator.
- AIFB 1 and AIFB 2 are not active out of the box. These blocks will show Out of Service on the LCD at startup. If these blocks are needed for an FF application, use a tool such as DeltaV or NI-FBUS Configurator to configure and schedule the blocks. See **Configuration** in manual *Foundation Fieldbus for Level Instruments* (7ML19985MP01) for further details.

Static Revision Number (2.6.1.)

The revision level of the static data associated with Analog Input Function Block 1. The Static Revision No. is updated whenever a configuration parameter is changed.

Mode (2.6.2.)

Used to request an operating mode from the Analog Input Function Block.

Options	Auto Mode (AUTO)
	Manual Mode (MAN)
	Out of Service (OOS)

Allows you to put the SITRANS LR250 into Out of Service Mode and then reset it to Auto Mode. Manual Mode can be used when simulating output. See **Simulation** in manual *Foundation Fieldbus for Level Instruments* (7ML19985MP01) for more details.

Channel (2.6.3.)

Used to select between the different Level Transducer Block outputs.

Options		Description	Reference point
LEVEL/VOLUME		Level value converted to Volume [through Linearization (2.4.)]	Low Calibration Point
LEVEL	*	Level value	Low Calibration Point
DISTANCE		Distance value	Sensor Reference Point

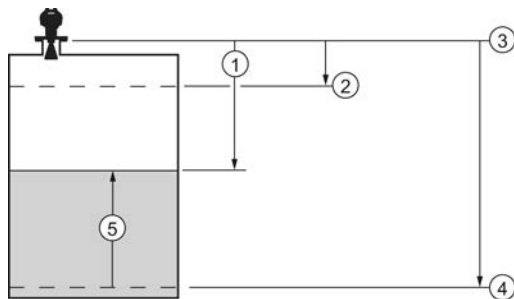

- ① Distance
- ② High Calibration Point (process full level)
- ③ Sensor reference point ^{a)}
- ④ Low Calibration Point (process empty level)
- ⑤ Level

^{a)} The point from which High and Low Calibration points are referenced: see Dimension drawings (Page 221) and Threaded Horn Antenna with extension (Page 221).

Input Scaling (2.6.4.)

Lower Value (2.6.4.1.)

Defines the operational lower range value of the input value (Process Value Scale) in PV (volume/level) Units. Process Value Scale normalizes the input value to a customer-defined range.

Values	Range: -999999 to 999999
	Default: 0 %

Upper Value (2.6.4.2.)

Defines the operational upper range value of the input value (Process Value Scale) in PV (volume/level) Units. Process Value Scale normalizes the input value to a customer-defined range.

Values	Range: -999999 to 999999
	Default: 100 %

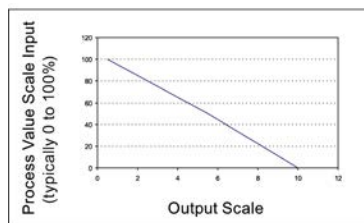

Provides Output values (Out) to AIFB 1 or AIFB 2

Unit (2.6.4.3.)

Engineering unit to be displayed with the output value.

Values		m, cm, mm, ft, in, cu m, L, HL, cu in, cu ft, cu yd, gal, imp gal, bushels, Bbl, Bbl liquid, percent, PA, Follow out unit
	*	%

Decimal Point (2.6.4.4.)

Read only. The number of digits to display after the decimal point (set to 0 decimal places).

Output Scaling (2.6.5.)

Scales the Process Variable. The function block parameter OUT SCALE contains the values of the lower limit and upper limit effective range in AIFB 1 units.

Lower Value (2.6.5.1.)

Defines the operational lower range value of the output value in AIFB 1 units.

Values	Range: -999999 to 999999
	Default: 0%

Upper Value (2.6.5.2.)

Defines the operational upper range value of the output value in AIFB1 units.

Values	Range: -999999 to 999999
	Default: 100%

Unit (2.6.5.3.)

Engineering unit to be displayed with the output value.

Values		m, cm, mm, ft, in, cu m, L, HL, cu in, cu ft, cu yd, gal, imp gal, bushels, Bbl, Bbl liquid, percent, PA, Follow out unit
	*	%

Decimal Point (2.6.5.4.)

Read only. The number of digits to display after the decimal point (set to two decimal places).

Alarms and Warnings (2.6.6.)

High Limit Alarm (2.6.6.1.)

The setting for the upper alarm limit in AIFB1 units.

Values	Range: -Infinity to Infinity
	Default: Inf

High Limit Warning (2.6.6.2.)

The setting for the upper warning limit in AIFB1 units.

Values	Range: -Infinity to Infinity
	Default: Inf

Low Limit Warning (2.6.6.3.)

The setting for the lower warning limit in AIFB1 units.

Values	Range: -Infinity to Infinity
	Default: -Inf

Low Limit Alarm (2.6.6.4.)

The setting for the lower alarm limit in AIFB1 units.

Values	Range: -Infinity to Infinity
	Default: -Inf

Limit Hysteresis (2.6.6.5.)

Hysteresis is used to adjust the sensitivity of the trigger for alarm messages. It is used to compensate when a process variable fluctuates around the same value as a limit. A high level alarm occurs when a value exceeds an upper limit. The alarm's status remains true until the value drops below the limit minus the alarm hysteresis. The directions are reversed for low limit detection.

Values	Range: 0 to 50
	Default: 0.50

Enter a value for the hysteresis here, to be used for all warnings and alarms. The units are the same as the Output scale, i.e. AIFB1 units.

Display (2.6.7.)**Filter Time Constant (2.6.7.1.)**

The time constant for the damping filter. The damping filter smooths out the response to a sudden change in level. This is an exponential filter and the engineering unit is always in seconds. See Damping (Page 273) for more detail.

Values	Range: 0 to 600 s
	Default: 0 ^{a)}

a) To meet accuracy specification, Filter Time Constant (PV_FTIME) must be changed from default of 0.0 s to a minimum of 10.0 seconds [see Performance (Page 213)].

AIFB 2 (2.7.)

See **AIFB1 (2.6.)**: the parameters for **AIFB 2** are identical to **AIFB 1**.

Measured Values (2.8.)

(for diagnostic purposes)

Read only. Allows you to view measured values for diagnostic purposes.

Main Output (PV - Primary Value) (2.8.1.)

The value for level, or volume (if volume conversion is selected).

In AMS Device Manager, see Process Variables Level Transducer Block-LTB (Page 128).

Output, no linearization (SV1 - Secondary Value 1) (2.8.2.)

The value for level.

Output, no level offset (SV2 - Secondary Value 2) (2.8.3.)

The value for distance.

Diagnostics (3.)

Echo Profile (3.1.)

Allows you to request the current echo profile via the handheld programmer, or via AMS Device Manager. For more detail see Echo Processing (Page 266).

To request a profile via AMS Device Manager:

See Echo Profile (Page 103).

To request a profile via the handheld programmer:

1. Navigate to **Level Meter > Diagnostics (3.) > Echo Profile (3.1.)**.
2. Press RIGHT arrow to request a profile. [See Requesting an Echo Profile (Page 70) for more details.]

Fault Reset (3.2.)

Clears faults (see chart below).

Clearing a fault in one parameter of a 'maintenance pair', automatically clears a fault in the second parameter of the pair. For example, entering S3 or S4 will clear a fault on Device Lifetime Reminder 1 (Maintenance Required), and on Device Lifetime Reminder 2 (Maintenance Demanded). This applies when clearing faults via the handheld programmer, or the 375 Field Communicator.

Fault code	Description
S3	Device Lifetime Reminder 1 (Maintenance Required)
S4	Device Lifetime Reminder 2 (Maintenance Demanded)
S6	Sensor Lifetime Reminder 1 (Maintenance Required)
S7	Sensor Lifetime Reminder 2 (Maintenance Demanded)
S8	Device Service Reminder 1 (Maintenance Required)
S9	Device Service Reminder 2 (Maintenance Demanded)
S12	Internal Temperature High
S17	Calibration Schedule Reminder 1 (Maintenance Required)
S18	Calibration Schedule Reminder 2 (Maintenance Demanded)

To clear a fault using the handheld programmer:

- Enter the fault code number then press **RIGHT arrow** .

Electronics Temperature (3.3.)

To access the following parameters via AMS Device Manager see **Electronics Temperature** under Maintenance & Diagnostics (LTB) (Page 104).

Minimum Value (3.3.1.)

The minimum recorded internal electronics temperature, reported in units defined in **Temperature Units (2.3.4.)**.

Maximum Value (3.3.2.)

The maximum recorded internal electronics temperature, reported in units defined in **Temperature Units (2.3.4.)**.

Peak Values (3.4.)

Minimum Measured Value (3.4.1.)

The minimum recorded Sensor value, reported in units defined in **Unit (2.3.1.)**.

Maximum Measured Value (3.4.2.)

The maximum recorded Sensor value, reported in units defined in **Unit (2.3.1.)**.

Service (4.)

Note

Default settings in the parameter tables are indicated with an asterisk (*) unless explicitly stated.

Master Reset (4.1.)

Note

- The following parameters are not reset by any reset type: Write Protection, PIN to Unlock, Auto False Echo Suppression Range, Learned TVT.
- While an FF Object Dictionary Reset is in progress, do not perform an action using the local display interface until the reset is complete. This could cause a temporary loss of communications.



Reset Type	Result
Factory Defaults ^{a)}	Default. Resets all user parameters to the manufacturer's default settings. Following this type of reset, complete reprogramming is required.
Standard Defaults	Resets all parameters to standard default settings.
Informational	Resets parameters such as Block Descriptor, Strategy, Device Install Date, Device Message.
Functional ^{a)}	Resets parameters that control device behavior and functionality (such as Low Calibration Point).
Warm Start	Has the same effect as recycling power to the device.
FF Object Dictionary	Resets the FF standard block profile parameters (such as block tags) to their specified defaults. This option also clears any function block parameters and device schedule ^{b)} set by the user.

^{a)} The only difference between Factory Defaults and Functional reset is that Factory Defaults resets maintenance parameters, such as device and sensor wear, calibration and maintenance timers. Functional reset does not reset these parameters.

^{b)} See **Data transmission** in manual *Foundation Fieldbus for Level Instruments* (7ML19985MP01) for further details.

To access via AMS Device Manager see Master Reset under Operation (RESOURCE) (Page 113).

To perform a reset via the handheld programmer:

1. Press **RIGHT arrow**  to open Edit Mode then scroll down to the desired reset type and press **RIGHT**  arrow to select it.
2. Press **LEFT arrow**  to exit.

After performing a master reset, the device will stop measuring, the Resource and Level Transducer Blocks will go to **Out of Service**, and the LUI will show the **Quick Start Wizard** until the device is configured.

Remaining Device Lifetime (4.2.)

Note

- Default settings in the parameter tables are indicated with an asterisk (*) unless explicitly stated.
 - Four sets of parameters allow you to monitor the Device/Sensor Lifetimes and set up Maintenance/Service schedules, based on operating hours instead of a calendar-based schedule. See also **Remaining Sensor Lifetime (4.3.)**, **Service Schedule (4.4.)**, and **Calibration Schedule (4.5.)**.
 - Performing a reset to **Factory Defaults** will reset all the Maintenance Schedule parameters to their factory defaults.
 - The device operates in years. To view Remaining Device Lifetime parameters in hours (via AMS Device Manager only) see **Remaining Device Lifetime** under Maintenance & Diagnostics (RESOURCE) (Page 116).
-

The device tracks itself based on operating hours and monitors its predicted lifetime. You can modify the expected device lifetime, set up schedules for maintenance alerts, and acknowledge them.

The maintenance warnings and alarms are communicated to the end user through status information. This information can be integrated into any Asset Management system.

To access these parameters via AMS Device Manager see **Remaining Device Lifetime** under Maintenance & Diagnostics (RESOURCE) (Page 116).

Time in operation (4.2.2.)

Read only. The amount of time the device has been operating.

Remaining lifetime (4.2.3.)

Read only. **Lifetime (Expected) (4.2.1.)** less **Time in Operation (4.2.2.)**.

Activation of Reminders (4.2.4.)

Allows you to enable a maintenance reminder.

Options		REMInder 1 (Maintenance REQUIred)
		REMInder 2 (Maintenance DEManded)
		REMinders 1 AND 2 (Maintenance Required and Maintenance Demanded)
	*	OFF

1. First set the reminder values in **Reminder 1 before Lifetime (Required) (4.2.5.)**/**Reminder 2 before Lifetime (Demanded) (4.2.6.)**.
2. Select the desired **Activation of Reminders** option.

Reminder 1 before Lifetime (Required) (4.2.5.)

If **Remaining Lifetime (4.2.3.)** is equal to or less than this value, the device generates a Maintenance Required reminder.

Values	Range: 0 to 20 years
	Default: 0.164 years

1. Modify limit values as required.
2. Set **Activation of Reminders (4.2.4.)** to the desired option.

Reminder 2 before Lifetime (Demanded) (4.2.6.)

If **Remaining Lifetime (4.2.3.)** is equal to or less than this value, the device generates a Maintenance Demanded reminder.

Values	Range: 0 to 20 years
	Default: 0.019 years

1. Modify values as required.
2. Set **Activation of Reminders (4.2.4.)** to the desired option.

Maintenance Status (4.2.7.)

Indicates which level of maintenance reminder is active.

To display the level of maintenance reminder that is active in AMS Device Manager see **Extended Diagnostics** under Device Diagnostics [Resource Block - RESOURCE (Page 124)].



Acknowledge Status (4.2.8.)

Indicates which level of maintenance reminder has been acknowledged.

Acknowledge (4.2.9.)

Acknowledges the current maintenance reminder.

To acknowledge a reminder via the handheld programmer:

1. Press **RIGHT arrow**  twice to open parameter view and activate **Edit Mode**.
2. Press **RIGHT arrow**  to acknowledge the reminder.

Remaining Sensor Lifetime (4.3.)

Note

- Default settings in the parameter tables are indicated with an asterisk (*) unless explicitly stated.
 - Four sets of parameters allow you to monitor the Device/Sensor Lifetimes and set up Maintenance/Service schedules, based on operating hours instead of a calendar-based schedule. See also **Remaining Device Lifetime (4.2.)**, **Service Schedule (4.4.)**, and **Calibration Schedule (4.5.)**.
 - Performing a reset to Factory Defaults will reset all the Maintenance Schedule parameters to their factory defaults.
 - The device operates in years. To view Remaining Sensor Lifetime parameters in hours (via AMS Device Manager only) see **Remaining Sensor Lifetime** in Maintenance & Diagnostics (LTB) (Page 104).
-

The device monitors the predicted lifetime of the sensor (the components exposed to the vessel environment). You can modify the expected sensor lifetime, set up schedules for maintenance reminders, and acknowledge them.

To access these parameters via AMS Device Manager see **Remaining Sensor Lifetime** in Maintenance & Diagnostics (LTB) (Page 104).

Lifetime (expected) (4.3.1.)

Allows you to override the factory default.

Values	Units: years
	Range: 0 to 20 years
	Default: 10.00 years

Time in Operation (4.3.2.)

The amount of time the sensor has been operating. Can be reset to zero after performing a service or replacing the sensor.

To reset to zero:

- Via the handheld programmer, manually reset **Time in Operation (4.3.2.)** to zero.

Remaining Lifetime (4.3.3.)

Read only. **Lifetime (expected) (4.3.1.)** less **Time in Operation (4.3.2.)**.

Activation of Reminders (4.3.4.)

Allows you to enable a maintenance reminder.

Options		REMinder 1 (Maintenance Required)
		REMinder 2 (Maintenance Demanded)
		REMiners 1 and 2 (Maintenance Required and Maintenance Demanded)
	*	OFF

1. First set the values in **Reminder 1 before Lifetime (Required) (4.3.5.)**/**Reminder 2 before Lifetime(Demanded) (4.3.6.)**.
2. Select the desired **Activation of Reminders** option.

Reminder 1 before Lifetime (Required) (4.3.5.)

If **Remaining Lifetime (4.3.3.)** is equal to or less than this value, the device generates a **Maintenance Required** reminder.

Values	Range: 0 to 20 years
	Default: 0.164 years

1. Modify limit values as required.
2. Set **Activation of Reminders (4.3.4.)** to the desired option.

Reminder 2 before Lifetime (Demanded) (4.3.6.)

If **Remaining Lifetime (4.3.3.)** is equal to or less than this value, the device generates a **Maintenance Demanded** reminder.

Values	Range: 0 to 20 years
	Default: 0.019 years

1. Modify limit values as required.
2. Set **Activation of Reminders (4.3.4.)** to the desired option.

Maintenance Status (4.3.7.)

Indicates which level of maintenance reminder is active.

To display the level of maintenance reminder in AMS Device Manager see **Extended Diagnostics** under Device Diagnostics (Level Transducer Block - LTB) (Page 119).



Acknowledge Status (4.3.8.)

Indicates which level of maintenance reminder has been acknowledged.

Acknowledge (4.3.9.)

Acknowledges the current maintenance reminder.

To acknowledge a reminder via the handheld programmer:

1. Press **RIGHT arrow**  twice to open parameter view and activate **Edit** Mode.
2. Press **RIGHT arrow**  to acknowledge the reminder.

Service Schedule (4.4.)

Note

- Default settings in the parameter tables are indicated with an asterisk (*) unless explicitly stated.
- Four sets of parameters allow you to monitor the Device/Sensor Lifetimes and set up Maintenance/Service schedules, based on operating hours instead of a calendar-based schedule. See also **Remaining Device Lifetime (4.2.)**, **Remaining Sensor Lifetime (4.3.)**, and **Calibration Schedule (4.5.)**.
- Performing a reset to **Factory Defaults** will reset all the Maintenance Schedule parameters to their factory defaults.
- The device operates in years. To view Service Interval parameters in hours or days (via AMS Device Manager only) see **Service Schedule (4.4.1.)**.

The device tracks service intervals based on operating hours and monitors the predicted lifetime to the next service. You can modify the Total Service Interval, set schedules for maintenance reminders, and acknowledge them.

The maintenance warnings and alarms are communicated to the end user through status information. This information can be integrated into any Asset Management system.

To access these parameters via AMS Device Manager see **Service Schedule** under Maintenance & Diagnostics (LTB) (Page 104).

Service Interval (4.4.1.)

User-configurable recommended time between product inspections.

Values	Units: years
	Range: 0 to 20 years
	Default: 1.0 year

Time Since Last Service (4.4.2.)

Time elapsed since last service. Can be reset to zero after performing a service.

To reset to zero:

- Via the handheld programmer, manually reset **Time Since Last Service (4.4.2.)** to zero.

Time Until Next Service (4.4.3.)

Read only. **Service Interval (4.4.1.)** less **Time Since Last Service (4.4.2.)**.

Activation of Reminders (4.4.4.)

Allows you to enable a maintenance reminder.

Options	*	Timer OFF
		ON NO LIMITS
		ON - REMinder 1 (Maintenance Required) checked
		ON - REMinders 1 and 2 checked
		ON - REMinder 2 (Maintenance Demanded) checked

1. First set the values in **Reminder 1 before Service (Required) (4.4.5.)/Reminder 2 before Service (Demanded) (4.4.6.)**.
2. Select the desired **Activation of Reminders** option.

Reminder 1 before Service (Required) (4.4.5.)

If **Time Until Next Service (4.4.3.)** is equal to or less than this value, the device generates a **Maintenance Required** reminder.

Values	Range: 0 to 20 years
	Default: 0.164 years

1. Modify limit values as required.
2. Set **Activation of Reminders (4.4.4.)** to the desired option.

Reminder 2 before Service (Demanded) (4.4.6.)

If **Time Until Next Service (4.4.3.)** is equal to or less than this value, the device generates a **Maintenance Demanded** reminder.

Values	Range: 0 to 20 years
	Default: 0.019 years

1. Modify values as required
2. Set **Activation of Reminders (4.4.4.)** to the desired option.

Maintenance Status (4.4.7.)

Indicates which level of maintenance reminder is active.

To display the level of maintenance reminder in AMS Device Manager see **Extended Diagnostics** under Device Diagnostics (Level Transducer Block - LTB) (Page 119).



Acknowledge Status (4.4.8.)

Indicates which level of maintenance reminder has been acknowledged.

Acknowledge (4.4.9.)

Acknowledges the current maintenance reminder.

To acknowledge a reminder via the handheld programmer:

1. Press **RIGHT**  **arrow** twice to open parameter view and activate **Edit Mode**.
2. Press **RIGHT**  **arrow** to acknowledge the reminder.

Calibration Schedule (4.5.)**Note**

- Default settings in the parameter tables are indicated with an asterisk (*) unless explicitly stated.
- Four sets of parameters allow you to monitor the Device/Sensor Lifetimes and set up Maintenance/Service schedules, based on operating hours instead of a calendar-based schedule. See also **Remaining Device Lifetime (4.2.)**, **Remaining Sensor Lifetime (4.3.)**, and **Service Schedule (4.4.)**.
- Performing a reset to **Factory Defaults** will reset all the Maintenance Schedule parameters to their factory defaults.
- The device operates in years. To view Calibration Interval parameters in hours (via AMS Device Manager only) see **Calibration Schedule** under Maintenance & Diagnostics (RESOURCE) (Page 116).

The device tracks calibration intervals based on operating hours and monitors the predicted lifetime to the next calibration. You can modify the Total Calibration Interval, set schedules for maintenance reminders, and acknowledge them.

To access these parameters via AMS Device Manager see **Calibration Schedule** under Maintenance & Diagnostics (RESOURCE) (Page 116).

Calibration Interval (4.5.1.)

User-configurable recommended time between product calibrations.

Values	Units: years
	Range: 0 to 20 years
	Default: 1.0 year

Time Since Last Calibration (4.5.2.)

Time elapsed since last calibration. Can be reset to zero after performing a calibration.

To reset to zero:

- Via the handheld programmer, manually reset **Time Since Last Calibration (4.5.2.)** to zero.

Time Until Next Calibration (4.5.3.)

Read only. **Calibration Interval (4.5.1.)** less **Time Since Last Calibration (4.5.2.)**.

Activation of Reminders (4.5.4.)

Allows you to enable a maintenance reminder.

Options	*	Timer OFF
		ON NO LIMITS
		ON - REMinder 1 (Maintenance Required) checked
		ON - REMinders 1 and 2 checked
		ON—REMinder 2 (Maintenance Demanded) checked

1. First set the limit values in **Reminder 1 before Calibration (Required) (4.5.5.)/Reminder 2 before Calibration (Demanded) (4.5.6.)**.
2. Select the desired **Activation of Reminders** option.

Reminder 1 before Calibration (Required) (4.5.5.)

If **Time Until Next Calibration (4.5.3.)** is equal to or less than this value, the device generates a **Maintenance Required** reminder.

Values	Range: 0 to 20 years
	Default: 0.164 years

1. Modify limit values as required.
2. Set **Activation of Reminders (4.5.4.)** to the desired option.

Reminder 2 before Calibration (Demanded) (4.5.6.)

If **Time Until Next Calibration (4.5.3.)** is equal to or less than this value, the device generates a **Maintenance Demanded** reminder.

Values	Range: 0 to 20 years
	Default: 0.019 years

1. Modify limit values as required.
2. Set **Activation of Reminders (4.5.4.)** to the desired option.

Maintenance Status (4.5.7.)

Indicates which level of maintenance reminder is active.

To display the level of maintenance reminder that is active in AMS Device Manager see **Extended Diagnostics** under Device Diagnostics (Resource Block - RESOURCE) (Page 124).



Acknowledge Status (4.5.8.)

Indicates which level of maintenance reminder has been acknowledged.

Acknowledge (4.5.9.)

Acknowledges the current maintenance reminder.

To acknowledge a reminder via the handheld programmer:

1. Press **RIGHT**  **arrow** twice to open parameter view and activate **Edit Mode**.
2. Press **RIGHT**  **arrow** to acknowledge the reminder.

Manufacture Date (4.6.)

Read only. The date of manufacture of the SITRANS LR250 (mm/dd/yyyyhh.mm).

Powered Hours (4.7.)

Read only. Displays the number of hours the unit has been powered up since manufacture.

To view via AMS Device Manager see **Wear** under Maintenance & Diagnostics (RESOURCE) (Page 116).

Power-on Resets (4.8.)

Read only. The number of power cycles that have occurred since manufacture.

To view via AMS Device Manager see **Wear** under Maintenance & Diagnostics (RESOURCE) (Page 116).

LCD Fast Mode (4.9.)

Note

- LCD Fast Mode takes effect only after 30 minutes of inactivity. (Each time the device is powered up, a further 30 minutes of inactivity is required.)
- LCD Fast Mode affects Measurement mode only; it has no effect on Navigation mode.

Enables a faster rate of measurement from the device by disabling most of the display area. Only the bar graph will be refreshed when LCD Fast Mode is set to ON.

Values	*	OFF
		ON

LCD Contrast (4.10.)

The factory setting is for optimum visibility at room temperature and in average light conditions. Extremes of temperature will lessen the contrast.

Values	Range: 0 (High contrast) to 20 (Low contrast). Default: 10
--------	--

Adjust the value to improve visibility at room temperature and in average light conditions. Change the value in small steps to ensure you can continue to read the display.

Secondary Value (4.11.)

Use the secondary value to capture the menu navigation path to any viewable parameter. Once the navigation path is stored, the value of that parameter will be displayed in **Measurement** mode as the secondary value.

While in Parameter View of the current parameter [see **Parameter View** under LCD Display (Page 57)], press the decimal point key. This stores the path to the current parameter in the Secondary Value, and displays the value for that parameter on the LCD display when in **Measurement** mode. See The LCD Display (Page 57) for an illustration.

Simulate Enable (4.12.)

Replaces a physical jumper switch found on some FF devices to enable simulation when set to ON. (Available only via LUI.)

Options	*	OFF	Simulation Disabled
		ON	Simulation Enabled

For more information on Simulation, see **Simulation (Input)** under Operation (LTB) (Page 93) in AMS Device Manager. [See also **Simulation** under **How the AIFB works** in manual *Foundation Fieldbus for Level Instruments* (7ML19985MP01)].

Communication (5.)**Note**

Default settings in the parameter tables are indicated with an asterisk (*) unless explicitly stated.

Tag (5.1.)**Note**

The tag can only be changed from a remote master such as NIFBUS-Configurator or DeltaV.

Read only. Text that can be used in any way. A recommended use is as a unique label for a field device in a plant. Limited to 32 ASCII characters.

Device Address (5.2.)**Note**

The address can only be changed from a remote master such as NIFBUS-Configurator or DeltaV. See **Addressing** in manual *Foundation Fieldbus for Level Instruments* (7ML19985MP01) for further details.

Read only. The unique address of the device on the network.

Values	Temporary range during initial commissioning: 248 - 251. Permanent range after commissioning complete (written to non-volatile memory in the device): 16-247
---------------	--

7.1 Operating via AMS Device Manager

Manufacturer (5.3.)

Name of manufacturer associated with this device.

Device Type Identification (5.4.)

Hexadecimal integer defined by Siemens to uniquely identify each product with manufacturer's Id. (LR250 FF device=0x1954.)

Device Revision (5.5.)

Manufacturer's revision number associated with this device.

ITK Version (5.6.)

Major revision number of the interoperability test case used to register this device.

Security (6.)

Note

Default settings in the parameter tables are indicated with an asterisk (*) unless explicitly stated.

Remote Access (6.1.)

Remote Lockout (6.1.1.)

Note

If remote lockout is changed to limit remote access, it can be reset only via the handheld programmer.

Enables or disables programming via the network and AMS Device Manager.

Options	*	OFF (Remote operation enabled)
		ON (Remote operation disabled)

Local Access (6.2.)**Write Protection (6.2.1.)****Note**

Do not lose this number value.

Prevents any changes to parameters via AMS Device Manager or the handheld programmer.

Hand-held programmer values		Range: 0 to 9999	
	*	Unlock value [stored in PIN to Unlock (6.2.2.)]	Lock Off
		Any other value	Lock On

- To turn Lock On, key in any value other than the Unlock Value stored in **PIN to Unlock (6.2.2.)**.
- To turn Lock Off, key in the Unlock Value stored in **PIN to Unlock (6.2.2.)**.

To access this parameter via AMS Device Manager see **Local Access** under Security (RESOURCE) (Page 119).

PIN to Unlock (6.2.2.)**Note**

- Do not lose your Unlock Value: it cannot be displayed once **Write Protection (6.2.1.)** has been set to a different value.
- A reset to **Factory Defaults** will not restore the unlock value at time of shipping.

Stores the value to be entered in **Write Protection (6.2.1.)** to unlock programming. If **Write Protection (6.2.1.)** is set to a different value, **PIN to Unlock (6.2.2.)** does not display the Unlock value.

Handheld Programmer Values	Range: 0 to 9999	
	Value when shipped: 1954. Not restored by a reset to Factory Defaults.	
	----	Display when Lock is on

To access this parameter via AMS Device Manager see **Local Access** under Security (RESOURCE) (Page 119).

Local Operation (6.2.3.)

Enables or disables programming via the handheld programmer.

Options		DISABLED
	*	ENABLED

Note

Once disabled via the handheld programmer, the parameter is no longer visible via LUI and can only be reset using AMS Device Manager. However, if no communication activity exists for 30 seconds, the parameter will again be visible via LUI.

To access this parameter via AMS Device Manager see **Local Display** under Setup (LCD) (Page 109).

Language (7.)

Selects the language to be used on the LCD.

Options	*	English
		Deutsch
		Français
		Español
		简体中文

To access this parameter via AMS Device Manager see **Local Display** under Setup (LCD) (Page 109).

8.1 Alphabetical parameter list

Note

For a detailed list of parameters see Parameter Reference (Page 143).

Acknowledge (4.2.9.)

Acknowledge (4.3.9.)

Acknowledge (4.4.9.)

Acknowledge (4.5.9.)

Acknowledge Status (4.2.8.)

Acknowledge Status (4.3.8.)

Acknowledge Status (4.4.8.)

Acknowledge Status (4.5.8.)

AIFB1 (2.6.)

AIFB2 (2.7.)

Alarms and Warnings (2.6.6.)

Algorithm (2.5.7.1.)

Auto False Echo Suppression (2.5.10.1.)

Auto False Echo Suppression Range (2.5.10.2.)

Breakpoints 1-9 (2.5.11.1.)

Breakpoints 10-18 (2.5.11.2.)

Breakpoints 19-27 (2.5.11.3.)

Breakpoints 28-36 (2.5.11.4.)

Breakpoints 37-40 (2.5.11.5.)

Calibration (2.3.7.)

Calibration Interval (4.5.1.)

Calibration Schedule (4.5.)

Channel (2.6.3.)

CLEF (Constrained Leading Edge Fit) Range (2.5.7.4.)

Communication (5.)

Confidence (2.5.9.1.)

Decimal Point (2.6.4.4.)

8.1 Alphabetical parameter list

Decimal Point (2.6.5.4.)
Descriptor (2.1.2.)
Device (2.2.)
Device Address (5.2.)
Device Revision (5.5.)
Device Type Identification (5.4.)
Diagnostics (3.)
Dimension A (2.4.1.3.)
Dimension L (2.4.1.4.)
Display (2.6.7.)
Down Sampling (2.5.8.3.)
Echo Lock (2.5.8.1.)
Echo Profile (3.1.)
Echo Quality (2.5.9.)
Echo Select (2.5.7.)
Echo Strength (2.5.9.2.)
Echo Threshold (2.5.7.3.)
Electronics Temperature (3.3.)
Empty Rate per Minute (2.3.8.3.)
Far Range (2.5.2.)
Fault Reset (3.2.)
Fill Rate per Minute (2.3.8.2.)
Filter Time Constant (2.6.7.1.)
Firmware Revision (2.2.2.)
Hardware Revision (2.2.1.)
High Calibration Pt. (2.3.7.2.)
High Level Point (2.3.7.5.)
High Limit Alarm (2.6.6.1.)
High Limit Warning (2.6.6.2.)
Hover Level (2.5.10.3.)
Input Scaling (2.6.4.)
ITK Version (5.6.)

Language (7.)
LCD Contrast (4.10.)
LCD Fast Mode (4.9.)
Level Offset (2.3.7.6.)
Level Unit (2.3.2.)
Lifetime (expected) (4.2.1.)
Lifetime (expected) (4.3.1.)
Limit Hysteresis (2.6.6.5.)
Linearization (2.4.)
Loader Revision (2.2.3.)
Local Access (6.2.)
Local Operation (6.2.3.)
Loss of Echo (LOE) Timer (2.3.6.)
Low Calibration Point. (2.3.7.1.)
Low Level Point (2.3.7.4.)
Low Limit Alarm (2.6.6.4.)
Low Limit Warning (2.6.6.3.)
Lower Value (2.6.4.1.)
Lower Value (2.6.5.1.)
Main Output (PV– Primary Value) (2.8.1.)
Maintenance Status (4.2.7.)
Maintenance Status (4.3.7.)
Maintenance Status (4.4.7.)
Maintenance Status (4.5.7.)
Manufacturer Date (4.6.)
Manufacturer (5.3.)
Master Reset (4.1.)
Material (2.3.5.)
Maximum Measured Value (3.4.2.)
Maximum Sensor Value (2.5.5.)
Minimum Value (3.3.2.)
Maximum Volume (2.4.1.2.)

Measured Values (2.8.)
Message (2.1.3.)
Minimum Measured Value (3.4.1.)
Minimum Sensor Value (2.5.4.)
Minimum Value (3.3.1.)
Mode (2.6.2.)
Near Range (2.5.1.)
Output Scaling (2.6.5.)
Output, no level offsets (SV2 – Secondary Value 2) (2.8.3.)
Output, no linearization (SV1 – Secondary Value 1) (2.8.2.)
Peak Values (3.4.)
Position Detect (2.5.7.2.)
Powered Hours (4.7.)
Power-on Resets (4.8.)
Propagation Factor (2.5.3.)
PV (volume/level) Units (2.3.3.)
Quick Start (1.)
Rate (2.3.8.)
Remaining Device Lifetime (4.2.)
Remaining Lifetime (4.2.3.)
Remaining Sensor Lifetime (4.3.)
Remaining Lifetime (4.3.3.)
Reminder 1 before Lifetime (Required) (4.2.5.)
Reminder 1 before Lifetime (Required) (4.3.5.)
Reminder 1 before Service (Required) (4.4.5.)
Reminder 1 before Calibration (Required) (4.5.5.)
Reminder 2 before Lifetime (Demanded) (4.2.6.)
Reminder 2 before Lifetime (Demanded) (4.3.6.)
Reminder 2 before Service (Demanded) (4.4.6.)
Reminder 2 before Calibration (Demanded) (4.5.6.)
Remote Access (6.1.)
Remote Lockout (6.1.1.)

Response Rate (2.3.8.1.)
Sampling (2.5.8.)
Secondary Value (4.11.)
Security (6.)
Sensor (2.3.)
Sensor Offset (2.3.7.3.)
Service (4.)
Service Interval (4.4.1.)
Service Schedule (4.4.)
Setup (2.)
Shaper Mode (2.5.10.4.)
Shots (2.5.6.)
Signal Processing (2.5.)
Simulate Enable (4.12)
Static Revision Number (2.6.1.)
Tag (2.1.1.)
Tag (5.1.)
Temperature Units (2.3.4.)
Time Until Next Calibration (4.5.3.)
Time Until Next Service (4.4.3.)
TVT (Auto False Echo Suppression) setup (2.5.10.)
TVT Shaper (2.5.11.)
Unit (2.3.1.)
Unit (2.6.4.3.)
Unit (2.6.5.3.)
Up Sampling (2.5.8.2.)
Upper Value (2.6.4.2.)
Upper Value (2.6.5.2.)
Vessel Shape (2.4.1.1.)
Volume (2.4.1.)
Write Protection (6.2.1.)
X value (2.4.1.6.)
XY index (2.4.1.5.)
Y value (2.4.1.7.)

Service and maintenance

9.1 Basic safety information

 WARNING
Impermissible repair of the device <ul style="list-style-type: none">• Repair must be carried out by Siemens authorized personnel only.

 CAUTION
Releasing key lock <p>Improper modification of parameters could influence process safety.</p> <ul style="list-style-type: none">• Make sure that only authorized personnel may cancel the key locking of devices for safety-related applications.

9.2 Cleaning

The radar device requires no cleaning under normal operating conditions.

Under severe operating conditions, the antenna may require periodic cleaning. If cleaning becomes necessary:

- Note the antenna material and the process medium, and select a cleaning solution that will not react adversely with either.
- Remove the device from service and wipe the antenna clean using a cloth and suitable cleaning solution.

NOTICE
Penetration of moisture into the device <p>Device damage.</p> <ul style="list-style-type: none">• Make sure when carrying out cleaning and maintenance work that no moisture penetrates the inside of the device.

 WARNING
Electrostatic charge Danger of explosion in hazardous areas if electrostatic charges develop, for example, when cleaning plastic surfaces with a dry cloth. <ul style="list-style-type: none">• Prevent electrostatic charging in hazardous areas.

9.3 Maintenance and repair work

The device is maintenance-free. However, a periodic inspection according to pertinent directives and regulations must be carried out.

An inspection can include check of:

- Ambient conditions
- Seal integrity of the process connections, cable entries, and cover screws
- Reliability of power supply, lightning protection, and grounds

 WARNING
Maintenance during continued operation in a hazardous area There is a danger of explosion when carrying out repairs and maintenance on the device in a hazardous area. <ul style="list-style-type: none">• Isolate the device from power. - or - <ul style="list-style-type: none">• Ensure that the atmosphere is explosion-free (hot work permit).

 WARNING
Humid environment Danger of electric shock. <ul style="list-style-type: none">• Avoid working on the device when it is energized.• If working on an energized device is necessary, ensure that the environment is dry.• Make sure when carrying out cleaning and maintenance work that no moisture penetrates the inside of the device.

9.3.1 Unit repair and excluded liability

All changes and repairs must be done by qualified personnel, and applicable safety regulations must be followed. Please note the following:

- The user is responsible for all changes and repairs made to the device.
- All new components must be provided by Siemens.
- Restrict repair to faulty components only.
- Do not re-use faulty components.

9.3.2 Part replacement

If the antenna, lens, secondary O-ring, and spring washers require replacement due to damage or failure, they may be replaced without the need for re-calibration if of the same type and size.

Replacing the antenna

Changing to a different antenna type may be performed by a Siemens authorized repair center or personnel.

If the electronics or enclosure require replacement due to damage or failure, please ensure the correct antenna version is used, otherwise a re-calibration will need to be performed by Siemens authorized personnel.

Replacing the lens

1. Remove existing lens by turning it counter-clockwise until it separates from the unit.
2. Replace the O-ring between the lens and process connection with a new one.
3. Carefully thread the replacement lens, and turn it clockwise until resistance is encountered. Do not over-tighten the lens, as this will permanently damage it.
4. For flange installation instructions, see Flanged versions (Page 37).

Note

After installation of the new lens onto the flanged encapsulated antenna version and before mounting on the vessel/tank, some lenses may not appear to lie flush on the device, but this is normal and will not impact performance.

Raised-Face flange kits

Description	Process connection size	Part number
Replacement TFM™ 1600 PTFE Lens and Spring Washer Kit for ASME B16.5 Class 150 raised faced	2"	A5E32462817
	3"	A5E32462819
	4"	A5E32462820
	6"	A5E32462821
Replacement TFM™ 1600 PTFE Lens and Spring Washer Kit for JIS B 2220 10K raised Face	50A	A5E32462822
	80A	A5E32462823
	100A	A5E32462824
	150A	A5E32462825
Replacement TFM™ 1600 PTFE Lens and Spring Washer Kit for EN 1092-1 PN10/16 type B1 raised face	DN50	A5E32462826
	DN80	A5E32462827
	DN100	A5E32462828
	DN150	A5E32462829

Spare part kits

Description	Process connection size	Part number
ISO2852, Hygienic encapsulated antenna Lens and silicon O-ring	2"	A5E32572731
	3"	A5E32572745
	4"	A5E32572747
DIN11851, Hygienic encapsulated antenna Lens and silicon O-ring	DN50	A5E32572758
	DN80	A5E32572770
	DN100	A5E32572772
DIN11864-1, Hygienic encapsulated antenna Lens and silicon O-ring	DN50	A5E32572773
	DN80	A5E32572779
	DN100	A5E32572782
DIN11864-2/3, Hygienic encapsulated antenna Lens and silicon O-ring	DN50	A5E32572785
	DN80	A5E32572790
	DN100	A5E32572791
Tuchenhagen, Hygienic encapsulated antenna Lens and silicon O-ring	Type F	A5E32572794
	Type N	A5E32572795

Note

For more information about accessories such as clamps, seals and process connections, please see the catalog on the product page (<http://www.siemens.com/LR250>).

9.4 Disposal

Note

Special disposal required

The device includes components that require special disposal.

- Dispose of the device properly and environmentally through a local waste disposal contractor.
-

Diagnosing and troubleshooting















1. Check the following:
 - There is power at the device.
 - The LCD shows the relevant data.
 - If any fault codes are being displayed see General Fault Codes (Page 205) for a detailed list.
2. Verify that the wiring connections are correct.
3. See the table below for specific symptoms.

Symptom	Corrective action
The device cannot be programmed via FF.	<ul style="list-style-type: none"> • Make sure Remote Lockout (6.1.1.) is set to the unlock value • Ensure block is Out of Service
You try to set a SITRANS LR250 parameter via remote communications but the parameter remains unchanged.	<ul style="list-style-type: none"> • Ensure Remote Lockout (6.1.1.) is disabled. • Ensure Write Protection (6.2.1.) is set to the unlock value. • Ensure block is Out of Service
The AIFB output equals the display value but does not correspond to actual material level.	<ul style="list-style-type: none"> • Ensure the Channel selection and Scaling in AIFB 1 are correctly entered • Ensure AIFBs are scheduled and in Auto mode • Ensure High Calibration Point is correctly entered • View the echo profile to see if the wrong echo is being selected. If so, see Operation Troubleshooting (Page 210) for possible causes and corrective action
The AIFB output is not equal to the displayed value (regardless of actual material level).	<ul style="list-style-type: none"> • Confirm you are looking at the AIFB Output • Ensure AIFBs are scheduled and in Auto mode • Ensure scaling has not been programmed into the controller: all scaling should be performed by the LR250 • Check the network to ensure the controller is communicating with the LR250
Not able to change parameters via LUI.	<ul style="list-style-type: none"> • Ensure Local Operation (6.2.3.) is enabled
Not able to change parameters, such as low calibration point.	<ul style="list-style-type: none"> • Ensure block is in Out of Service mode

If you continue to experience problems go to our website and check the FAQs for SITRANS LR250:

Product page (<http://www.siemens.com/LR250>), or contact your Siemens representative.







10.1 Device status icons











Icon	Priority Level	Meaning
	1	<ul style="list-style-type: none"> Maintenance alarm Measurement values are not valid
	2	<ul style="list-style-type: none"> Maintenance warning: maintenance demanded immediately Measured signal still valid
	3	<ul style="list-style-type: none"> Maintenance required Measured signal still valid
	1	<ul style="list-style-type: none"> Process value has reached an alarm limit
	2	<ul style="list-style-type: none"> Process value has reached a warning limit
	3	<ul style="list-style-type: none"> Process value has reached a tolerance limit
	1	<ul style="list-style-type: none"> Configuration error Device will not work because one or more parameters/components is incorrectly configured
	2	<ul style="list-style-type: none"> Configuration warning Device can work but one or more parameters/components is incorrectly configured
	3	<ul style="list-style-type: none"> Configuration changed Device parameterization not consistent with parameterization in project. Look for info text.
	1	<ul style="list-style-type: none"> Manual operation (local override) Communication is good; device is in manual mode.
	2	<ul style="list-style-type: none"> Simulation or substitute value Communication is good; device is in simulation mode or works with substitute values.
	3	<ul style="list-style-type: none"> Out of operation Communication is good; device is out of action.
		<ul style="list-style-type: none"> No data exchange
		<ul style="list-style-type: none"> Write access enabled
		<ul style="list-style-type: none"> Write access disabled

10.2 General fault codes













Note









- If more than one fault is present, the device status indicator and text for each fault alternate at 2 second intervals.

Code/ Icon	Meaning	Corrective Action
S: 0 	The device was unable to get a measurement within the Fail-safe LOE Timer period. Possible causes: faulty installation, antenna material buildup, foaming/other adverse process conditions, invalid configuration range.	<ul style="list-style-type: none"> • Ensure installation details are correct. • Ensure no antenna material buildup. Clean if necessary. • Adjust process conditions to minimize foam or other adverse conditions. • Correct configuration range. • If fault persists, contact your local Siemens representative.
S: 2 	Unable to collect profile because of a power condition that is outside the operating range of the device.	Repair required: contact your local Siemens representative.
S: 3 	Device is nearing its lifetime limit as defined in Remaining Lifetime (4.2.3.) and has triggered a Maintenance Required reminder (4.2.5.) .	Replacement is recommended
S: 4 	Device is nearing its lifetime limit as defined in Remaining Lifetime (4.2.3.) and has triggered a Maintenance Demanded reminder (4.2.6.) .	Replacement is recommended.
S: 6 	Sensor is nearing its lifetime limit as defined in Remaining Lifetime (4.3.3.) and has triggered a Maintenance Required reminder (4.3.5.) .	Replacement is recommended.
S: 7 	Sensor is nearing its lifetime limit as defined in Remaining Lifetime (4.3.3.) and has triggered a Maintenance Demanded reminder (4.3.6.) .	Replacement is recommended.
S: 8 	Service interval (4.4.1.) has expired and has triggered a Maintenance Required reminder (4.4.5.) .	Perform service.

Code/ Icon	Meaning	Corrective Action
S: 9 	Service interval (4.4.1.) has expired and has triggered a Maintenance Demanded reminder (4.4.6.) .	Perform service.
S: 10 	Input parameters Low Calibration Point (2.3.7.1.) and High Calibration Point (2.3.7.2.) are the same.	<ul style="list-style-type: none"> • Check calibration settings of device. • Ensure settings for High Calibration Point and Low Calibration Point are different.
S: 11 	Internal temperature sensor failure.	Repair required: contact your local Siemens representative.
S: 12 	Internal temperature of device has exceeded specifications: it is operating outside its temperature range.	<ul style="list-style-type: none"> • Relocate device and/or lower process temperature enough to cool device. • Inspect for heat-related damage and contact your local Siemens representative if repair is required. • Fault code will persist until a manual reset is performed using AMS or the LCD interface.
S: 17 	Calibration interval (4.5.1.) has expired and has triggered a Maintenance Required reminder (4.5.5.) .	Perform calibration.
S: 18 	Calibration interval (4.5.1.) has expired and has triggered a Maintenance Demanded reminder (4.5.6.) .	Perform calibration.
S: 22 	Time Base Fault	Hardware problem: contact your local Siemens representative.
S: 28 	Internal device failure caused by a RAM memory error.	Repair required: contact your local Siemens representative.
S: 29 	EEPROM damaged.	Repair required: contact your local Siemens representative
S: 31 	Flash error.	Repair required: contact your local Siemens representative
S: 33 	Factory calibration for the internal temperature sensor has been lost.	Repair required: contact your local Siemens representative





Code/ Icon	Meaning	Corrective Action
S: 34 	Factory calibration for the device has been lost.	Repair required: contact your local Siemens representative
S: 35 	Factory calibration for the device has been lost.	Repair required: contact your local Siemens representative
S: 36 	Unable to start microwave module.	Repair required: contact your local Siemens representative
S: 37 	Measurement hardware problem.	Repair required: contact your local Siemens representative
S: 38 	Microwave module hardware failure: unable to calculate distance measurement.	Repair required: contact your local Siemens representative
S: 43 	Factory calibration for the radar receiver has been lost.	Repair required: contact your local Siemens representative.
S: 92 	Corrupt Stack	Contact your local Siemens representative and provide configuration file and FB schedule.
S: 93 	High Stack	Contact your local Siemens representative and provide configuration file and FB schedule.
S: 94 	Data Safe Read	Re-apply configuration and cycle power. If fault persists, contact your local Siemens representative.
S: 95 	Data Safe Write	Re-apply configuration and cycle power. If fault persists, contact your local Siemens representative.
S: 96 	Safe Process Data Corrupt	Contact your local Siemens representative and provide configuration file and FB schedule.
S: 97 	Board Voltage	Hardware problem: contact your local Siemens representative.

Code/ Icon	Meaning	Corrective Action
S: 98 	ADC Failed	Hardware problem: contact your local Siemens representative.
S: 99 	Prof. Clip	Hardware problem. If fault persists contact your local Siemens representative.
S: 100 	Few Shots	Hardware problem. If fault persists contact your local Siemens representative.
S: 101 	Meas. Err.	Reset configuration. If fault persists contact your local Siemens representative and provide configuration file and FB schedule.
S: 102 	No Shots	Hardware problem. If fault persists contact your local Siemens representative.
S: 103 	Meas. Corrupt	Contact your local Siemens representative and provide configuration file and FB schedule.
S: 104 	DMA Error	Hardware problem. If fault persists contact your local Siemens representative.
S: 105 	Seq. Corrupt	Contact your local Siemens representative and provide configuration file and FB schedule.
S: 106 	Seq. CP	Re-install firmware (firmware upgrade). If fault persists contact your local Siemens representative.
S: 107 	Seq. Duration	Increase update rate limit. If fault persists contact your local Siemens representative.
S: 108 	BC Corrupt	Contact your local Siemens representative and provide configuration file and FB schedule.
S: 109 	BC Start	Re-install firmware (firmware upgrade). If fault persists contact your local Siemens representative.

Code/ Icon	Meaning	Corrective Action
S: 110 	BC Stop	Re-install firmware (firmware upgrade). If fault persists contact your local Siemens representative.
S: 111 	BC Duration	Hardware problem. If fault persists contact your local Siemens representative.
S: 112 	CPU Fault	Hardware problem. If fault persists contact your local Siemens representative.
S: 113 	Data Bus	Hardware problem. If fault persists contact your local Siemens representative.
S: 114 	Addr Bus	Hardware problem. If fault persists contact your local Siemens representative.
S: 115 	Spur SW	Hardware problem. If fault persists contact your local Siemens representative.
S: 116 	Spur HW	Hardware problem. If fault persists contact your local Siemens representative.
S: 117 	SV High	Verify TB not in simulation mode. If fault persists contact your local Siemens representative.
S: 118 	SV Low	Verify TB not in simulation mode. If fault persists contact your local Siemens representative.

10.3 Operation troubleshooting

Operating symptoms, probable causes, and resolutions.

Symptom	Cause	Action
Display shows  S: 0 LOE	level or target is out of range	<ul style="list-style-type: none"> check specifications check Low Calibration Pt. (2.3.7.1.) increase Confidence (2.5.9.1.)
Display shows  S: 0 LOE	material build-up on antenna	<ul style="list-style-type: none"> clean the antenna re-locate SITRANS LR250
Display shows  S: 0 LOE	location or aiming: <ul style="list-style-type: none"> poor installation flange not level Auto False Echo Suppression may be incorrectly applied 	<ul style="list-style-type: none"> check to ensure nozzle is vertical ensure end of antenna protrudes from end of nozzle review Auto False Echo Suppression (Page 271) ensure Auto False Echo Suppression Range is set correctly
Display shows  S: 0 LOE	antenna malfunction: <ul style="list-style-type: none"> temperature too high physical damage excessive foam multiple echoes 	<ul style="list-style-type: none"> check temperature in Maximum Value (3.3.2.) use foam deflector or stillpipe relocate use a defoamer set Algorithm (2.5.7.1.) to tF (trueFirst echo)
Reading does not change, but the level does	SITRANS LR250 processing wrong echo, for example, vessel wall, or structural member	<ul style="list-style-type: none"> re-locate SITRANS LR250 check nozzle for internal burrs or welds rotate device 90° use Auto False Echo Suppression (2.5.10.1.) if necessary: see Auto False Echo Suppression (Page 271)
Measurement is consistently off by a constant amount	<ul style="list-style-type: none"> setting for Low Calibration Point (2.3.7.1.) not correct setting for Sensor Offset (2.3.7.3.) not correct 	<ul style="list-style-type: none"> check distance from sensor reference point to Low Calibration Point (2.3.7.1.) check Sensor Offset (2.3.7.3.)
Screen blank	power error	<ul style="list-style-type: none"> check nameplate rating against voltage supply check power wiring or source
	too much load resistance	<ul style="list-style-type: none"> change barrier type, or remove something from the loop, or increase supply voltage reduce wire distance or use larger gage wire

Symptom	Cause	Action
Reading erratic	echo confidence weak	<ul style="list-style-type: none"> refer to Confidence (2.5.9.1.) use Auto False Echo Suppression (2.5.10.1.) and Auto False Echo Suppression Range (2.5.10.2.) use foam deflector or stillpipe
	liquid surface vortexed	<ul style="list-style-type: none"> decrease Fill Rate (2.3.8.2.) relocate device to side pipe increase confidence threshold in Echo Threshold (2.5.7.3.)
	material filling	<ul style="list-style-type: none"> Re-locate SITRANS LR250
Reading response slow	Fill Rate (2.3.8.2.) setting incorrect	<ul style="list-style-type: none"> increase measurement response if possible
Reads correctly but occasionally reads high when vessel is not full	<ul style="list-style-type: none"> detecting close range echo build up near top of vessel or nozzle nozzle problem 	<ul style="list-style-type: none"> clean the antenna use Auto False Echo Suppression (2.5.10.1.) and Auto False Echo Suppression Range (2.5.10.2.)
Level reading lower than actual material level	<ul style="list-style-type: none"> material is within Near Range zone multiple echoes processed 	<ul style="list-style-type: none"> decrease Near Range (2.5.1.) (minimum value depends on antenna type) raise SITRANS LR250 ensure Algorithm (2.5.7.1.) is set to tF (First echo)
	<ul style="list-style-type: none"> vessel near empty and low dK material 	<ul style="list-style-type: none"> ensure Material (1.2.) selection is LIQUID LOW DK set Position Detect (2.5.7.2.) to Hybrid check the setting for CLEF Range (2.5.7.4.): see the table below Propogation Factor (2.5.3.) for recommended settings

Technical data

Note

- Siemens makes every attempt to ensure the accuracy of these specifications but reserves the right to change them at any time.
-

11.1 Power

	General Purpose Intrinsically Safe Non-Sparking Non-incendive (FM/CSA US/Canada only)	9-32 V DC
---	--	-----------

Bus powered	9-32 V DC, per IEC 61158-2 (Foundation Fieldbus)
Current consumed	20 mA

11.2 Performance

Reference operating conditions according to IEC 60770-1

Ambient temperature	15 to 25 °C (59 to 77 °F)
Humidity	45 to 75% relative humidity
Ambient pressure	860 to 1060 mbar a (86000 to 106000 N/m ² a)
Interference reflections	minimum 20 dB lower than the main target reflection

Measurement Accuracy (measured in accordance with IEC 60770-1)

Maximum measured error	=3 mm (0.12") ^{1) 2) 3)} including hysteresis and non-repeatability	
Frequency	K-band	
Maximum measurement range ⁴⁾	1.5" antenna	10 m (32.8 ft) ⁵⁾
	2" threaded PVDF antenna	
	2"/DN50/50A Flangedencapsulated antenna (FEA)	
	2" ISO 2852, DN50 DIN11864-1/2/3, DN50 DIN11851, Tuchenhausen Types F and N Hygienic encapsulated antenna (HEA)	
	all other versions	20 m (65.6 ft)
Minimum detectable distance	50 mm (2") from end of antenna ⁶⁾	
Update time ⁷⁾	minimum 1 second, depending on settings for Response Rate (2.3.8.1.) and LCD Fast Mode (4.9.) .	
Influence of ambient temperature	< 0.003% / K (average over full temperature range, referenced to maximum range)	
Dielectric constant of material measured	dK > 1.6 [antenna and application dependent ⁸⁾]	
Memory	non-volatile EEPROM	
	no battery required	

1) The statistical accuracy is typically 3 mm (0.12") 90% of the time, when tested in accordance with IEC 60770-1.

2) Under severe EMI/EMC environments per IEC 61326-1 or NAMUR NE21, the device error may increase to a maximum of 10 mm (0.4").

3) For 2" threaded PVDF antenna, Flanged encapsulated antennas and Hygienic encapsulated antennas, the maximum measured error <500 mm from the sensor reference point =25 mm (1").

4) From sensor reference point: see Dimension drawings (Page 221) and Flanged Horn with extension (Page 228).

5) 20 m (65.6 ft) possible in a stillpipe/bypass

6) Minimum range is antenna length +50 mm (2"). See Dimension drawings (Page 221).

7) Reference conditions: **Response Rate (2.4.1.)** set to **FAST**, **LCD Fast Mode (4.9.)** set to **ON**.

8) For 1.5" (40 mm) antenna and 2" (50 mm) threaded PVDF antenna, 2"/DN50/50A flanged encapsulated antenna and 2" ISO 2852, DN50 DIN 11864-1/2/3, DN50 DIN11851, Tuchenhausen Types F and N hygienic encapsulated antenna the minimum dK is limited to 3 unless a stillpipe is used.

11.3 Interface

Communication:	Foundation Fieldbus	
	ITK version 5	Blocks supported: RESOURCE, LTB, AIFB1, AIFB2, LCD, DIAG Block execution time: AIFB - 40 ms
Configuration	Remote	FF host system or Emerson AMS (PC)
	Local	Siemens Milltronics infrared handheld programmer [see Programmer (infrared keypad) (Page 220), or Field Communicator 375 (Page 291)]
	Display (local) ¹⁾	graphic LCD, with bar graph (representing level)

¹⁾ Display quality will be degraded in temperatures below $-25\text{ }^{\circ}\text{C}$ ($-13\text{ }^{\circ}\text{F}$) and above $+65\text{ }^{\circ}\text{C}$ ($+149\text{ }^{\circ}\text{F}$).

11.4 Mechanical

Process connection:	Threaded connection	1.5" NPT (ASME B1.20.1), R (BSPT, EN 10226-1) ^{a)} or G (BSPP, EN ISO 228-1) or 2" NPT (ASME B1.20.1), R (BSPT, EN 10226-1) or G (BSPP, EN ISO 228-1) or 3" NPT (ASME B1.20.1), R (BSPT, EN 10226-1) or G (BSPP, EN ISO 228-1)
	Flange connection (flat-face)	2", 3", 4" (ASME 150 lb, 300 lb) DN50, DN80, DN100 (PN 10/16, PN 25/40) 50A, 80A, 100A (JIS 10K)
	Materials	316L /1.4404 or 316L /1.4435 stainless steel
	Flange connection (raised face)	DN50, DN80, DN100, DN150 (PN 10/16, PN 25/40)
	Materials	1.4404 or 1.4435 stainless steel, optional Alloy N06022/2.4602 (Hastelloy [®] C-22 or equivalent)
	Flanged encapsulated antenna (FEA) connection (raised face)	2, 3, 4, 6" (ASME 150 lb); DN50, DN80, DN100, DN150 (PN10/16); 50A, 80A, 100A, 150A (JIS 10K)
Materials	316L /1.4404 or 316L /1.4435 stainless steel	
Hygienic encapsulated antenna (HEA) connection	ISO 2852 (2, 3, 4") DIN 11851 (DN50, DN80, DN100) DIN 11864-1/2/3 (DN50, DN80, DN100) Tuchenhagen (Type F [50 mm and Type N [68 mm]) 316L /1.4404 or 316L /1.4435 stainless steel	

Technical data

11.4 Mechanical

	Materials	ISO 2852 (2, 3, 4") DIN 11864-3 (DN50, DN80, DN100)	clamp: 304/1.4301 stainless steel
		Tuchenhagen (Type F [50 mm] and Type N [68 mm]) 316L /1.4404 or 316L /1.4435 stainless steel	clamp: 304/1.4301 stainless steel nut connection: 303/1.4305 stainless steel
		DIN 11851/11864-1 (DN50, DN80, DN100)	captive slotted nut connection: 304L/1.4307
		DIN 11864-2 (DN50, DN80, DN100)	mounting nuts and bolts: 304/1.4301 stainless steel
Antenna:	Horn	standard 1.5" (40 mm), 2" (50 mm), 3" (80 mm), and 4" (100 mm) horn, optional 100 mm (4") horn extension	
	Materials	316L stainless steel with PTFE emitter optional Alloy N06022/2.4602 (Hastelloy®C-22 or equivalent) with PTFE emitter	
	Threaded PVDF antenna	2" (50 mm)	
	Wetted materials	PVDF (Polyvinylidene fluoride)	
	Flanged encapsulated antenna	316L /1.4404 or 316L /1.4435 stainless steel	
	Wetted materials	TFM™ 1600 PTFE lens	
	Hygienic encapsulated antenna	316L/1.4404 or 316L/1.4435 stainless steel	
Wetted material	TFM™ 1600 PTFE (plus chosen seal)		
Enclosure	Construction	aluminum, polyester powder-coated	
	Conduit entry	2 x M20x1.5, or 2 x ½" NPT	
	Ingress protection	Type 4X/NEMA 4X, Type 6/NEMA 6, IP67, IP68	
Weight (excluding extensions):	1.5" threaded connection with 1.5" horn antenna	approximately 5.1 kg (11.2 lb)	
	2" threaded connection with 2" horn antenna	approximately 5.5 kg (12.1 lb)	
	3" threaded connection with 3" horn antenna	approximately 7.0 kg (15.4 lb)	
	2" threaded PVDF antenna	approximately 3.3 kg (7.27 lb)	
	DN50 PN 10/16 or 2" 150 lb flat-face flange with 2" horn antenna	approximately 8 kg (17.6 lb)	
	DN100 PN 25/40 or 4" ASME 300 lb flat- face flange with 4" horn antenna	approximately 17.4 kg (38.3 lb)	
	DN50 PN 10/16 raised-face flange with 2" horn antenna	approximately 6 kg (13.2 lb)	

DN100 PN 25/40 raised-face flange with 4" horn antenna	approximately 11.3 kg (24.9 lb)
2" ASME 150 lb FEA	approximately 7.0 kg (15.4 lb)
3" ASME 150 lb FEA	approximately 10.7 kg (23.6 lb)
4" ASME 150 lb FEA	approximately 13.1 kg (28.9 lb)
6" ASME 150 lb FEA	approximately 17.7 kg (39 lb)
DN50 PN 10/16 FEA	approximately 7.1 kg (15.7 lb)
DN80 PN 10/16 FEA	approximately 10.1 kg (22.3 lb)
DN100 PN 10/16 FEA	approximately 11.1 kg (24.5 lb)
DN150 PN 10/16 FEA	approximately 15.9 kg (35.1 lb)
50 A JIS 10K FEA	approximately 6.5 kg (14.3 lb)
80 A JIS 10K FEA	approximately 9 kg (19.8 lb)
100 A JIS 10K FEA	approximately 10.1 kg (22.3 lb)
150 A JIS 10K FEA	approximately 16.3 kg (35.9 lb)
2" ISO 2852 HEA	approximately 4.7 kg (10.4 lb)
3" ISO 2852 HEA	approximately 6.3 kg (13.9 lb)
4" ISO 2852 HEA	approximately 6.8 kg (15 lb)
DN50 DIN 11864-1 HEA	approximately 4.8 kg (10.6 lb)
DN80 DIN 11864-1 HEA	approximately 6.7 kg (14.8 lb)
DN100 DIN 11864-1 HEA	approximately 7.1 kg (15.7 lb)
DN50 DIN 11864-2 HEA	approximately 5.0 kg (11 lb)
DN80 DIN 11864-2 HEA	approximately 7.2 kg (15.9 lb)
DN100 DIN 11864-2 HEA	approximately 7.9 kg (17.4 lb)
DN50 DIN 11864-3 HEA	approximately 4.8 kg (10.6 lb)
DN80 DIN 11864-3 HEA	approximately 6.6 kg (14.6 lb)
DN100 DIN 11864-3 HEA	approximately 7.2 kg (15.9 lb)
DN50 DIN 11851 HEA	approximately 4.8 kg (10.6 lb)
DN80 DIN 11851 HEA	approximately 6.8 kg (15 lb)
DN100 DIN 11851 HEA	approximately 7.2 kg (15.9 lb)
Tuchenhagen Type F HEA	approximately 4.8 kg (10.6 lb)
Tuchenhagen Type N HEA	approximately 4.9 kg (10.8 lb)

a) For use with 1.5" (40 mm) horn antennas only.

11.5 Environmental

Note

- For the specific configuration you are about to use or install, check transmitter nameplate and see Approvals (Page 219).
- Use appropriate conduit seals to maintain IP or NEMA rating.

Location	indoor/ outdoor
Altitude	5000 m (16,404 ft) max.
Ambient temperature	-40 to +80 °C (-40 to +176 °F)
Relative humidity	suitable for outdoor Type 4X/NEMA 4X, Type 6/NEMA 6, IP67, IP68 enclosure (see note above)
Installation category	I
Pollution degree	4

11.6 Process

Note

The maximum temperature is dependent on the process connection, antenna materials, and vessel pressure. For more detailed information see Maximum Process Temperature Chart (Page 274) and Process Pressure/Temperature derating curves (Page 276).

Temperature at process connection	Standard Horn antenna (Threaded or Flanged):	with FKM O-ring	-40 to +200 °C (-40 to +392 °F)
		with FFKM O-ring	-20 to +200 °C (-4 to +392 °F)
	2" NPT / BSPT / G Threaded PVDF antenna:		-40 to +80 °C (-40 to +176 °F)
	Flanged encapsulated antenna (FEA)		-40 to +170 °C (-40 to +338 °F)
	Hygienic encapsulated antenna (HEA)		-40 to +170 °C (-40 to +338 °F)
			with FKM seals used on process connection: -20 to +170 °C (-4 to +338 °F)
		with EPDM seals used on process connection: -40 to +120 °C (-40 to +248 °F)	
Pressure (vessel)		Refer to process connection tag and Process Pressure/Temperature derating curves (Page 276).	

11.7 Approvals

Note

The device nameplate lists the approvals that apply to your device.

Application type	LR250 version	Approval rating	Valid for:
Non-hazardous	General purpose	CSAus/c, FM, CE, RCM	N. America, Europe
	Radio	Europe (R&TTE), FCC, Industry Canada	
Hazardous	Intrinsically safe (Page 48)	ATEX II 1G, Ex ia IIC T4 Ga ATEX II 1D, Ex ia ta IIIC T100 °C Da	Europe
		IECEx SIR 09.0148X, Ex ia IIC T4 Ga Ex ia ta IIIC T100 °C Da	International
	FM/CSA Class I, Div. 1, Groups A, B, C, D Class II, Div. 1, Groups E, F, G Class III T4	US/Canada	
	INMETRO DNV 12.0090 X Ex ia IIC T4 Ga Ex ia ta IIIC T100 °C Da IP65/IP67 -40 °C ≤ Ta ≤ +80 °C DNV #OCP 0017 ABNT NBR IEC 60079-0:2008, ABNT NBR IEC 60079-11:2009, ABNT NBR IEC 60079-26:2008 e ABNT NBR IEC 60079-31:2011	Brazil	
	NEPSI Ex ia IIC T4 Ga Ex iaD 20 T90 IP6X DIP A20 TA 90°C	China	
	Non-Sparking (Page 51)	ATEX II 3 G, Ex nA IIC T4 Gc NEPSI Ex nA IIC T4 Gc	Europe China
Non-incendive (Page 51)	FM/CSA Class I, Div. 2, Groups A, B, C, D T5	US/Canada	
Marine	Lloyd's Register of Shipping ABS Type Approval BV Type Approval		
Hygienic/Sanitary		EHEDG EL Class I	International
		EHEDG EL Class I Aseptic	
		3-A Sanitary Standards	

11.8 Programmer (infrared keypad)

Note

Battery is non-replaceable with a lifetime expectancy of 10 years in normal use. To estimate the lifetime expectancy, check the nameplate on the back for the serial number. The first six numbers show the production date (mmddyy), for example, serial number 032608101V was produced on March 26, 2008.

Siemens Milltronics Infrared IS (Intrinsically Safe) Handheld Programmer for hazardous and all other locations (battery is non-replaceable).

Approvals	CE FM/CSA Class I, II, III, Div. 1, Gr. A to G T6 ATEX II 1GD Ex ia IIC T4 Ga Ex iaD 20 T135 °C IECEX Ex ia IIC T4 Ga Ex iaD 20 T135 °C INMETRO Ex ia IIC T4 Ga Ex ia IIIC T135 °C Da
Ambient temperature	-20 to +50 °C (-5 to +122 °F)
Interface	proprietary infrared pulse signal
Power	3 V non-replaceable lithium battery
Weight	150 g (0.3 lb)
Color	black
Part number	7ML1930-1BK

Dimension drawings

12.1 Threaded horn antenna

Note

- Process temperature and pressure capabilities are dependent upon information on the process connection tag. Reference drawing listed on the tag is available for download from our website under **Support/Installation drawings/Level Measurement/Continuous - Radar/LR250**:
Product page (<http://www.siemens.com/LR250>)
 - Process connection drawings are also available for download from the **Installation Drawings page**.
 - Signal amplitude increases with horn diameter, so use the largest practical size.
 - Optional extensions can be installed below the threads.
-

Dimension drawings

12.1 Threaded horn antenna

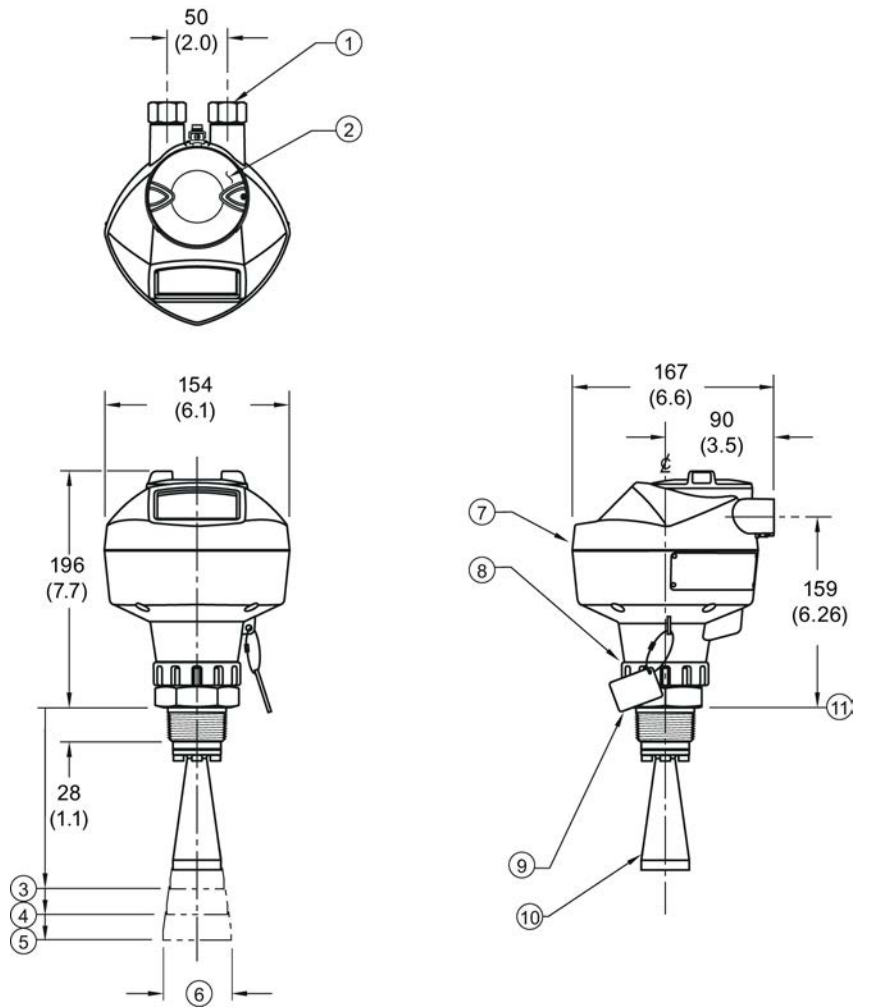

- | | |
|--|--------------------------|
| ① 1/2" NPT cable entry, or M20 cable gland | ⑦ enclosure/electronics |
| ② threaded cover | ⑧ retaining collar |
| ③ 2" horn | ⑨ process connection tag |
| ④ 3" horn | ⑩ horn |
| ⑤ 4" horn | ⑪ sensor reference point |
| ⑥ horn O.D. | |

Dimensions in mm (inch)

Threaded horn dimensions

Antenna Type	Antenna O.D. in mm (inch)	Height to sensor reference point, in mm (inch) ^{a)}			Beam Angle (°) ^{b)}	Measurement range, in m (ft)
		1-1/2" threaded connection	2" threaded connection	3" threaded connection		
1.5"	39.8 (1.57)	135 (5.3)	N/A	N/A	19	10 (32.8)
2"	47.8 (1.88)	N/A	166 (6.55)	180 (7.09)	15	20 (65.6)
3"	74.8 (2.94)	N/A	199 (7.85)	213 (8.39)	10	20 (65.6)
4"	94.8 (3.73)	N/A	254 (10)	268 (10.55)	8	20 (65.6)

^{a)} Height from bottom of horn to sensor reference point as shown: see dimension drawing.

^{b)} -3dB in the direction of the polarization axis. For an illustration, see Polarization reference point (Page 31).

12.2 Threaded horn antenna with extension

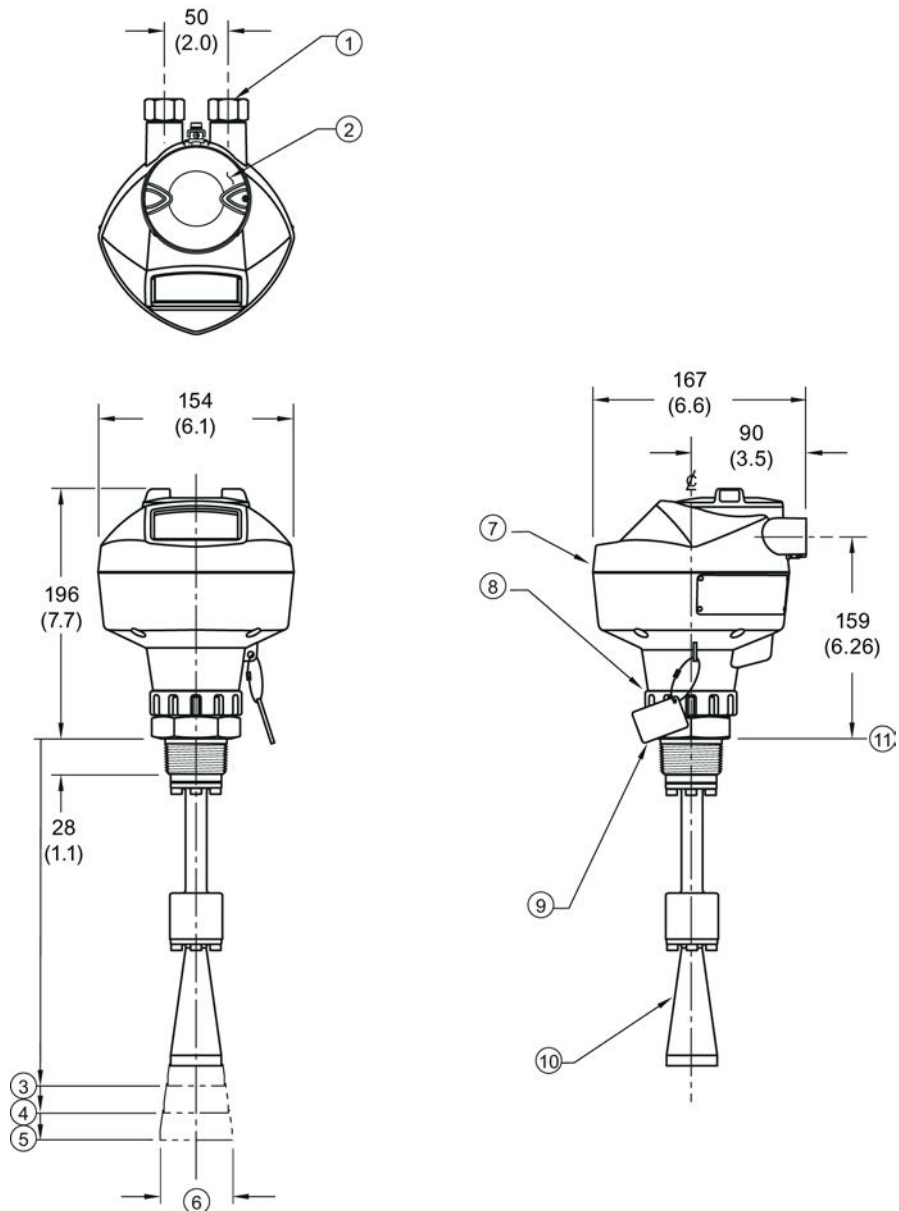

- | | | | |
|---|--|---|------------------------|
| ① | ½" NPT cable entry, or M20 cable gland | ⑦ | enclosure/electronics |
| ② | threaded cover | ⑧ | retaining collar |
| ③ | 2" horn | ⑨ | process connection tag |
| ④ | 3" horn | ⑩ | horn |
| ⑤ | 4" horn | ⑪ | sensor reference point |
| ⑥ | horn O.D. | | |

Dimensions in mm (inch)

Threaded horn with extension dimensions

Antenna Type	Antenna O.D. in mm (inch)	Height to sensor reference point, in mm (inch) ^{a)}			Beam Angle (°) ^{b)}	Measurement range in m (ft)
		1-1/2" threaded connection	2" threaded connection	3" threaded connection		
1.5"	39.8 (1.57)	235 (9.25)	N/A	N/A	19	10 (32.8)
2"	47.8 (1.88)	N/A	266 (10.47)	280 (11.02)	15	20 (65.6)
3"	74.8 (2.94)	N/A	299 (11.77)	313 (12.32)	10	20 (65.6)
4"	94.8 (3.73)	N/A	354 (13.94)	368 (14.49)	8	20 (65.6)

^{a)} Height from bottom of horn to sensor reference point as shown: see dimension drawing.

^{b)} -3dB in the direction of the polarization axis. For an illustration, see Polarization reference point (Page 31).

12.3 Flanged horn antenna

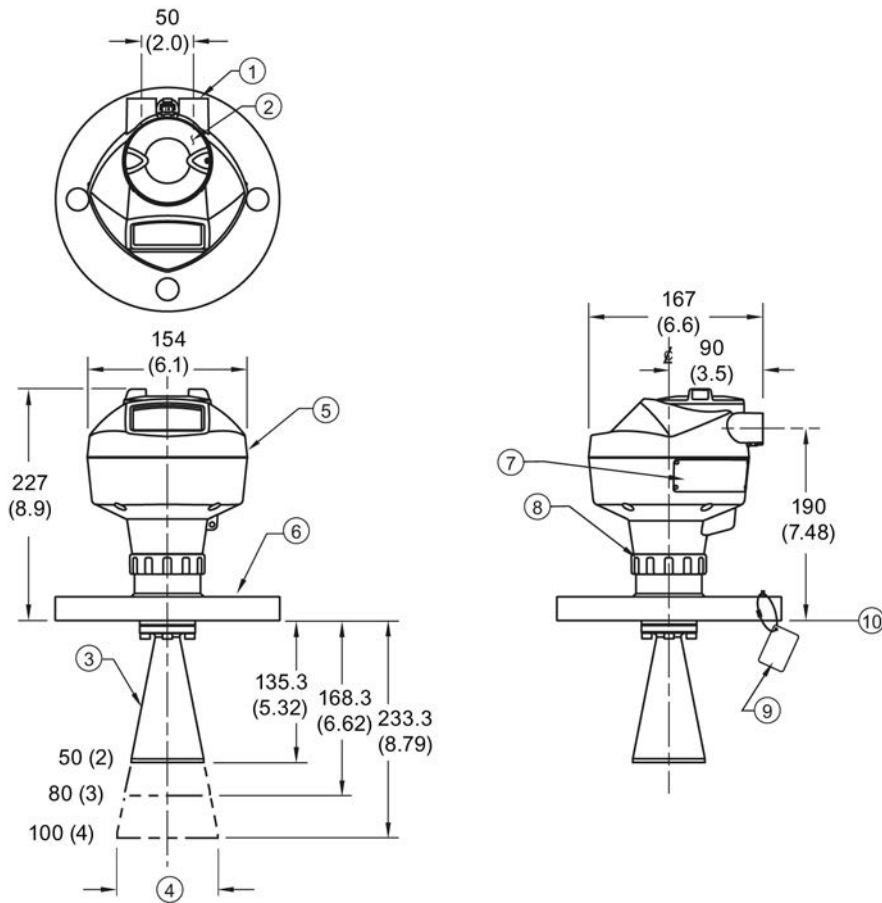

- | | | | |
|---|--|---|------------------------|
| ① | ½" NPT cable entry, or M20 cable gland | ⑥ | flange |
| ② | threaded cover | ⑦ | name-plate |
| ③ | horn | ⑧ | retaining collar |
| ④ | horn O.D. | ⑨ | process connection tag |
| ⑤ | enclosure/electronics | ⑩ | sensor reference point |

Dimensions in mm (inch)

Flanged Horn dimensions

Nominal horn size in mm (inch)	Horn O.D. in mm (inch)	Height to sensor reference point, in mm (inch) ^{a)}		Beam angle (°) ^{b)}	Measurement range, in m (ft)
		Stainless steel flange: raised or flat-face	Optional alloy flange ^{c)}		
50 (2)	47.8 (1.88)	135.3 (5.32)	138.3 (5.44)	15	
80 (3)	74.8 (2.94)	168.3 (6.62)	171.3 (6.74)	10	20 (65.6)
100 (4)	94.8 (3.73)	223.3 (8.79)	226.3 (8.90)	8	

^{a)}Height from bottom of horn to sensor reference point as shown: see Flanged horn antenna with extension (Page 228). See also Raised-Face flange per EN 1092-1 for flanged horn antenna (Page 253), or Flat-Face flange (Page 258).

^{b)}-3dB in the direction of the polarization axis (see Polarization reference point (Page 31) for an illustration).

^{c)}Optional alloy N06022/2.4602 (Hastelloy® C-22 or equivalent). See Raised-Face Flange Dimensions (Page 253).

Note

Heights to sensor reference point are for stainless steel flanges. For optional alloy N06022/2.4602 (Hastelloy® C-22 or equivalent) see Flanged Horn dimensions above.

12.4 Flanged horn antenna with extension

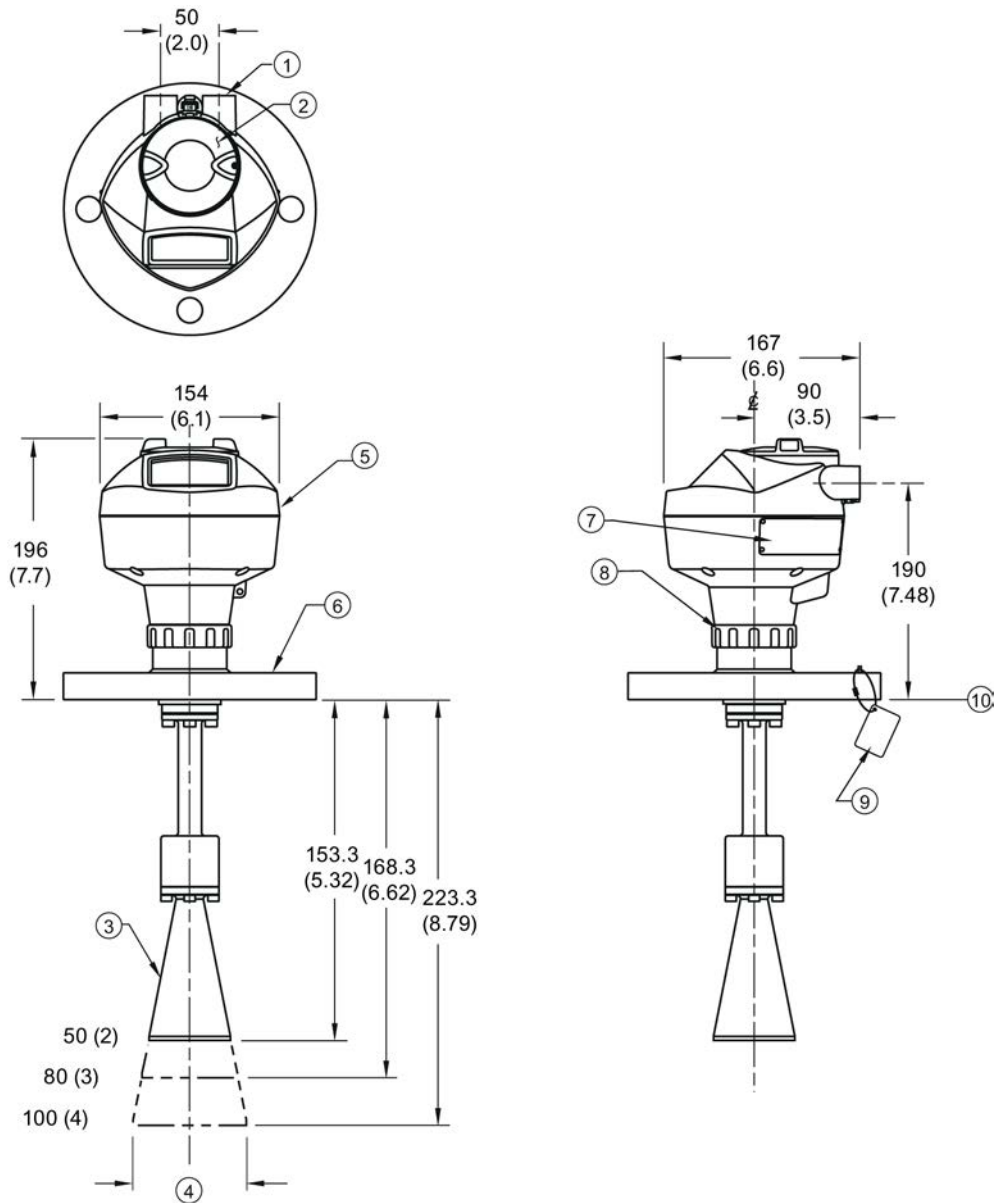

- | | |
|--|--------------------------|
| ① ½" NPT cable entry, or M20 cable gland | ⑥ flange |
| ② threaded cover | ⑦ name-plate |
| ③ horn | ⑧ retaining collar |
| ④ horn O.D. | ⑨ process connection tag |
| ⑤ enclosure/electronics | ⑩ sensor reference point |

Dimensions in mm (inch)

Flanged horn with extension dimensions

Nominal horn size in mm (inch)	Horn O.D. in mm (inch)	Height to sensor reference point, in mm (inch) ^{a)}		Beam angle (°) ^{b)}	Measurement range, in m (ft)
		Stainless steel flange: raised or flat-face	Optional alloy flange ^{c)}		
50 (2)	47.8 (1.88)	235.3 (9.26)	238.3 (9.38)	15	
80 (3)	74.8 (2.94)	268.3 (10.56)	271.3 (10.68)	10	20 (65.6)
100 (4)	94.8 (3.73)	323.3 (12.73)	326.3 (12.85)	8	

^{a)}Height from bottom of horn to sensor reference point as shown: See also Flanged horn antenna (Page 226) or Flat-Face Flange. (Page 258)

^{b)}-3dB in the direction of the polarization axis (see Polarization reference point (Page 31) for an illustration).

^{c)}Optional alloy N06022/2.4602 (Hastelloy® C-22 or equivalent). See Raised-Face flange per EN 1092-1 for flanged horn antenna (Page 253).

Note

Heights to sensor reference point are for stainless steel flanges. For optional alloy N06022/2.4602 (Hastelloy® C-22 or equivalent) see Flanged Horn dimensions above.

12.5 Flanged encapsulated antenna (2"/DN50/50A sizes only)

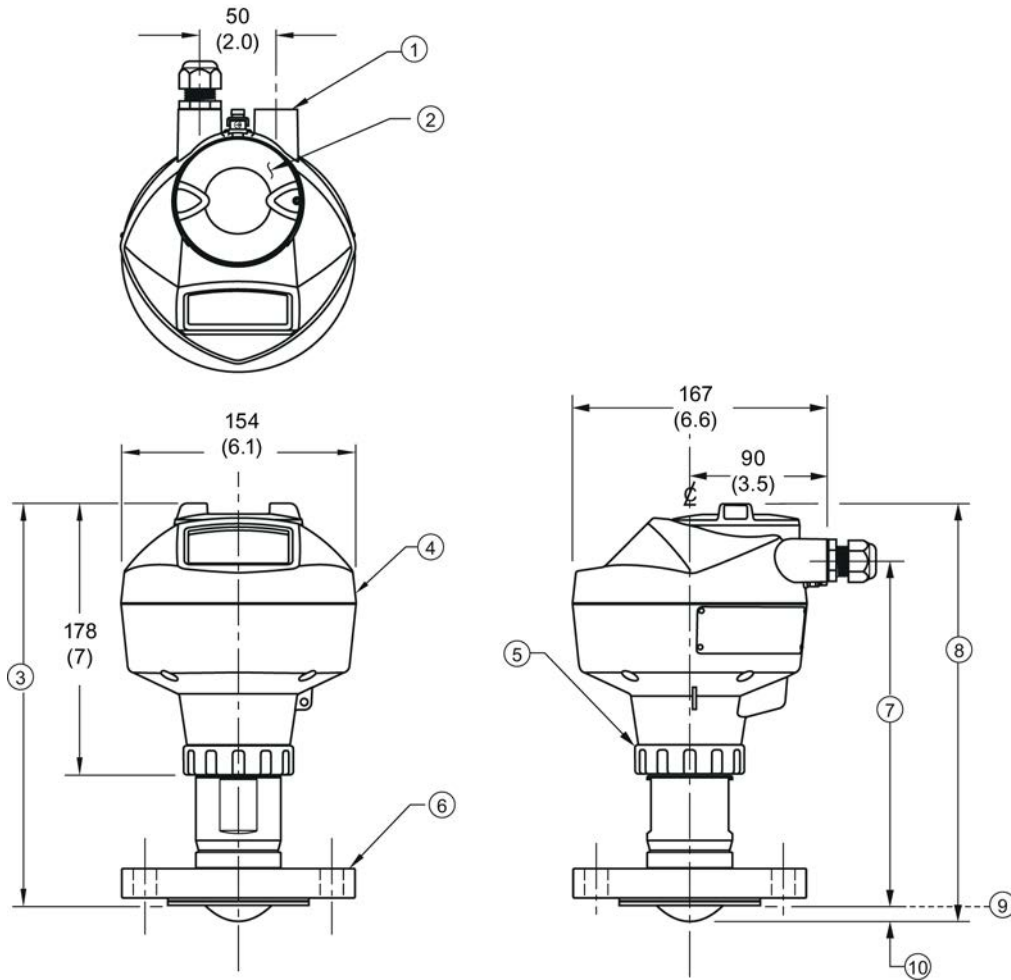

- | | | | |
|---|--|---|------------------------|
| ① | ½" NPT cable entry, or M20 cable gland | ⑥ | flange |
| ② | threaded cover | ⑦ | see table below |
| ③ | see table below | ⑧ | see table below |
| ④ | enclosure | ⑨ | sensor reference point |
| ⑤ | retaining collar | ⑩ | see table below |

Dimensions in mm (inch)

12.5 Flanged encapsulated antenna (2"/DN50/50A sizes only)

Flanged encapsulated antenna (2"/DN50/50A) dimensions

Flange size	③ mm (inch)	⑦ mm (inch)	⑧ mm (inch)	⑩ mm (inch) ¹⁾
2"/DN50/50A	263 (10.35)	223 (8.78)	274 (10.79)	11 (0.43)

1) Height from tip of lens to sensor reference point as shown.

Flange size	Flange class	Flange O.D. [mm (inch)]	Antenna aperture size [mm (inch)]	Beam angle (°) ¹⁾	Measurement range [m (ft)]
2"	150 LB	152 (5.98)	50 (1.97)	12.8	10 (32.8) ²⁾
DN50	PN10/16	165 (6.50)			
50A	10K	155 (6.10)			

1) -3 dB in the direction of the polarization axis.

2) 20m if installed in stillpipe

See Raised-Face Flange per EN 1092-1, (Page 255) and Polarization reference point (Page 31).

12.6 Flanged encapsulated antenna (3"/DN80/80A sizes and larger)

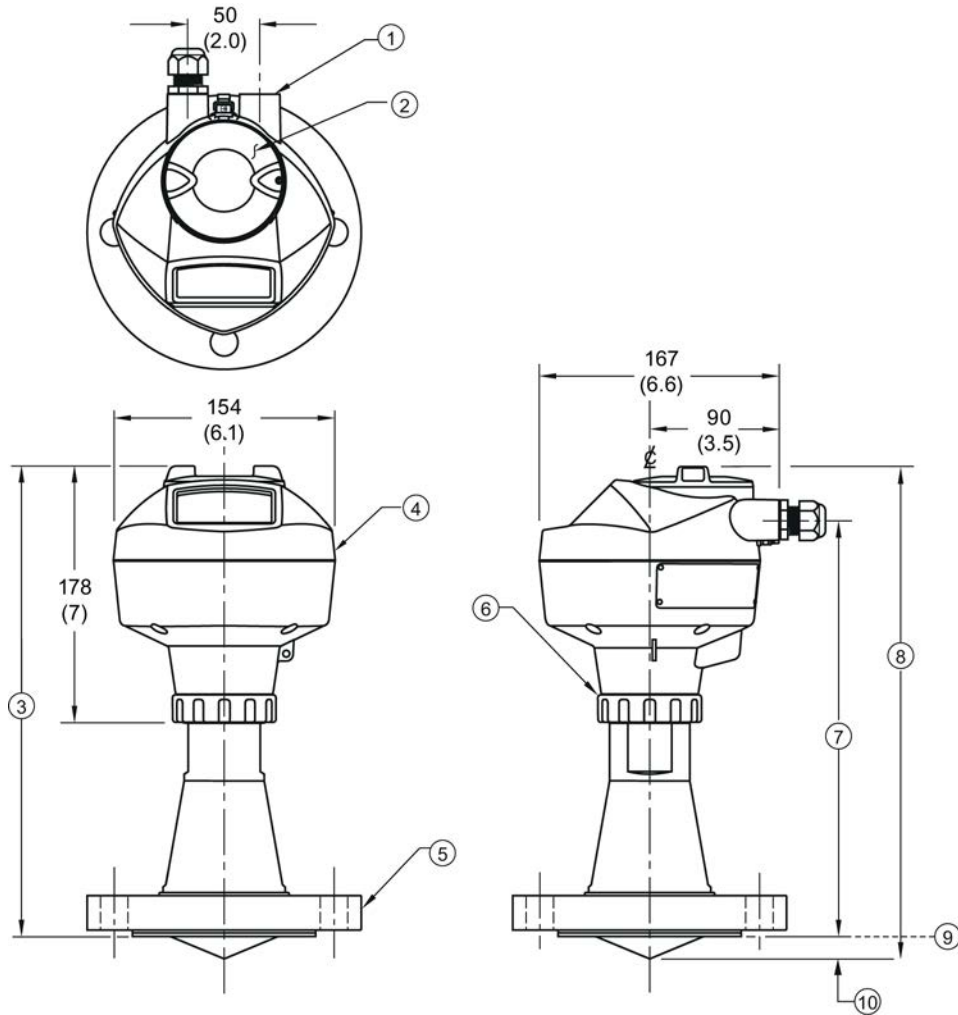

- | | | | |
|---|--|---|------------------------|
| ① | ½" NPT cable entry, or M20 cable gland | ⑥ | retaining collar |
| ② | threaded cover | ⑦ | see table below |
| ③ | see table below | ⑧ | see table below |
| ④ | enclosure | ⑨ | sensor reference point |
| ⑤ | flange | ⑩ | see table below |

Dimensions in mm (inch)

12.6 Flanged encapsulated antenna (3"/DN80/80A sizes and larger)

Flanged encapsulated antenna (3"/DN80/80A and larger) dimensions

Flange size	③ mm (inch)	⑦ mm (inch)	⑧ mm (inch)	⑩ mm (inch) ¹⁾
3"/DN80/80A	328 (12.91)	288 (11.34)	343 (13.50)	15 (0.59)
4"/DN100/100A	328 (12.91)	288 (11.34)	343 (13.50)	13 (0.51)
6"/DN150/150A	333 (13.11)	293 (11.54)	348 (13.70)	15 (0.59)

1) Height from tip of lens to sensor reference point as shown. See also Raised-Face Flange per EN 1092-1.

Flange size	Flange class	Flange O.D. [mm (inch)]	Antenna aperture size [mm (inch)]	Beam angle (°) ¹⁾	Measurement range [m (ft)]
3"	150 LB	190 (7.48)	75 (2.95)	9.6	20 (65.6)
DN80	PN10/16	200 (7.87)			
80A	10K	185 (7.28)			
4"	150 LB	230 (9.06)	75 (2.95)	9.6	20 (65.6)
DN100	PN10/16	220 (8.66)			
100A	10K	210 (8.27)			
6"	150 LB	280 (11.02)	75 (2.95)	9.6	20 (65.6)
DN150	PN10/16	285 (11.22)			
150A	10K	280 (11.02)			

1) -3 dB in the direction of the polarization axis.

See Raised-Face Flange per EN 1092-1 (Page 255), and Polarization reference point (Page 31).

12.7 Hygienic encapsulated antenna (2" ISO 2852 sanitary clamp)

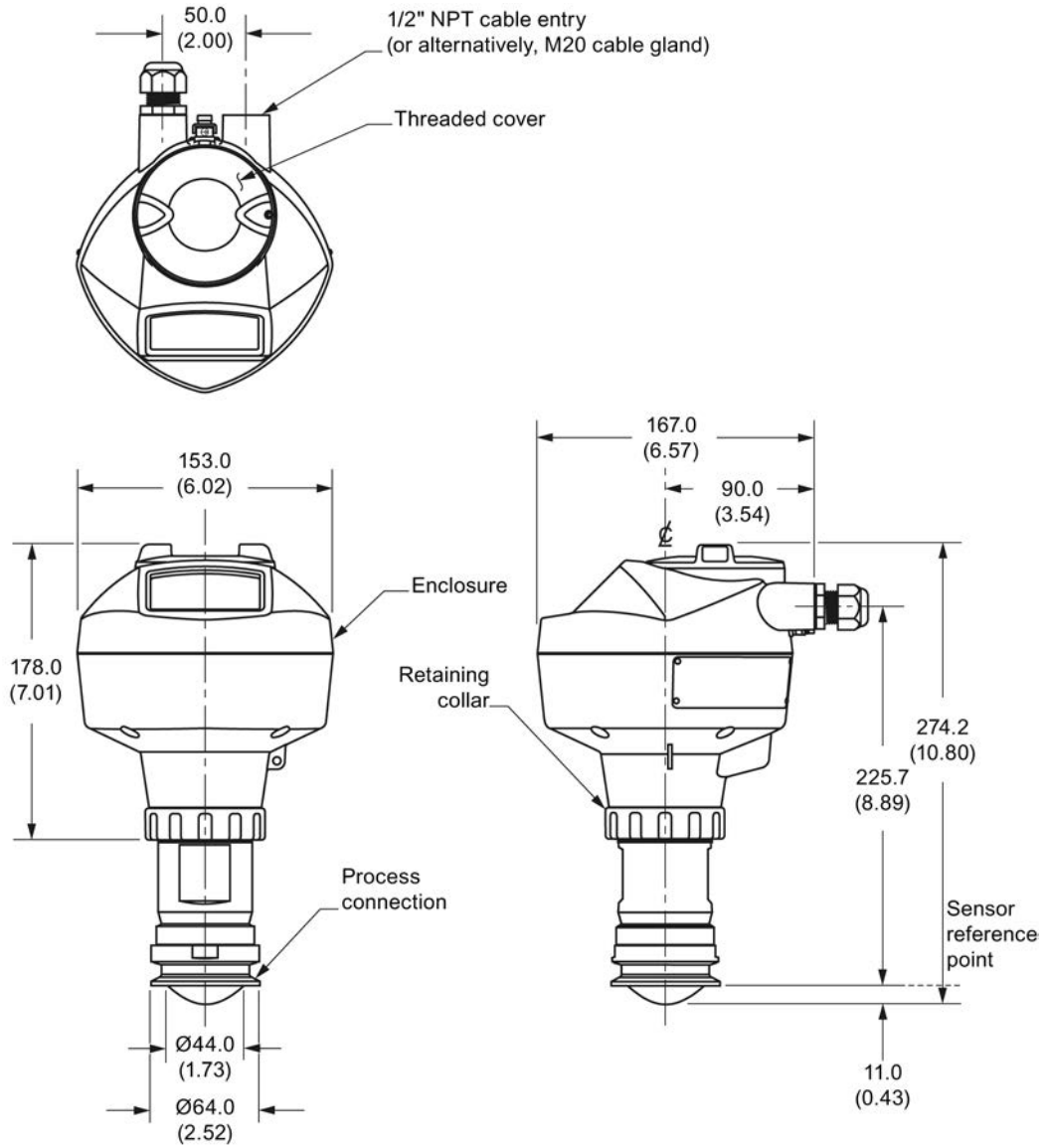

Dimensions in mm (inch)

12.8 Hygienic encapsulated antenna (3" ISO 2852 sanitary clamp)

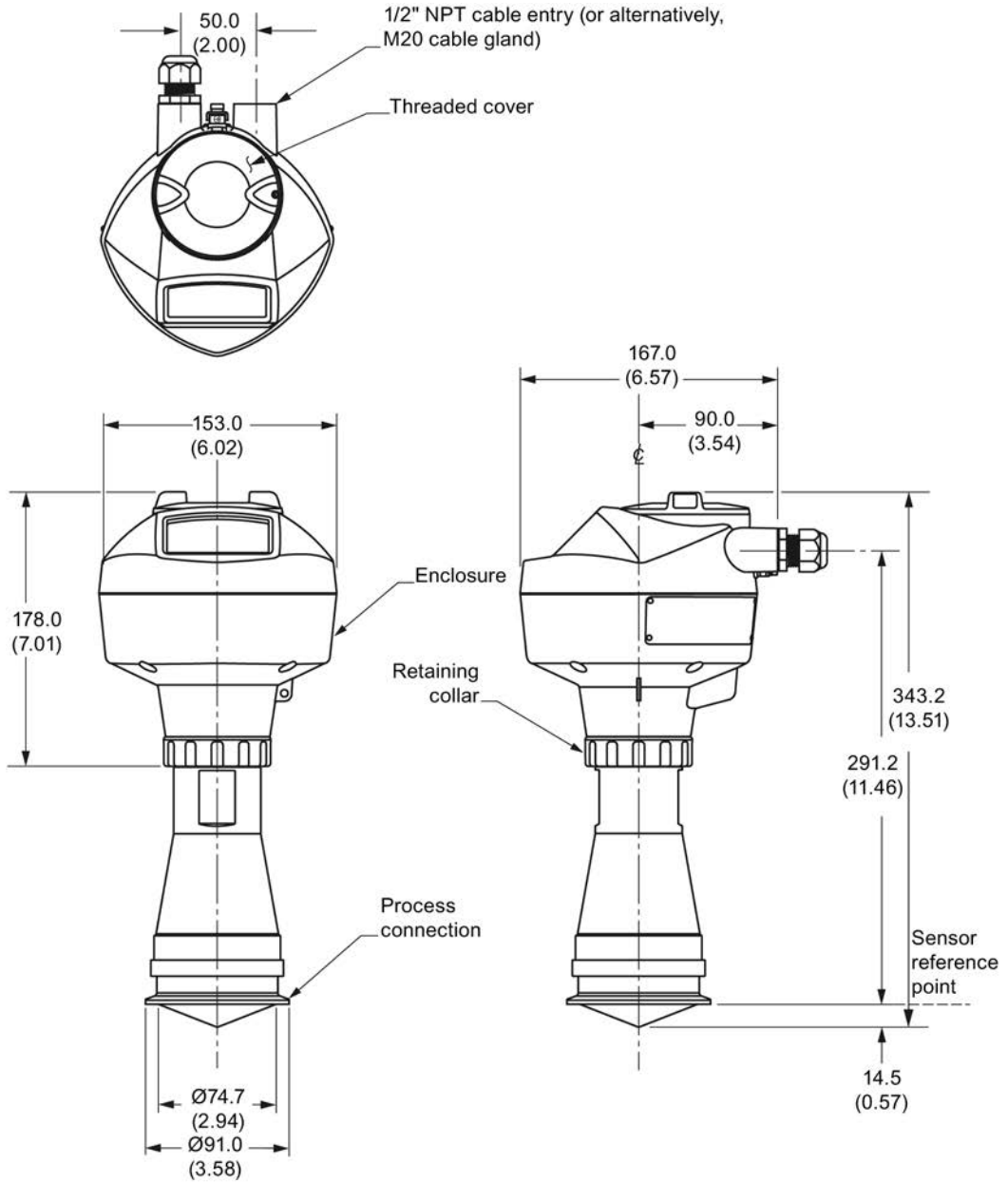

Dimensions in mm (inch)

12.9 Hygienic encapsulated antenna (4" ISO 2852 sanitary clamp)

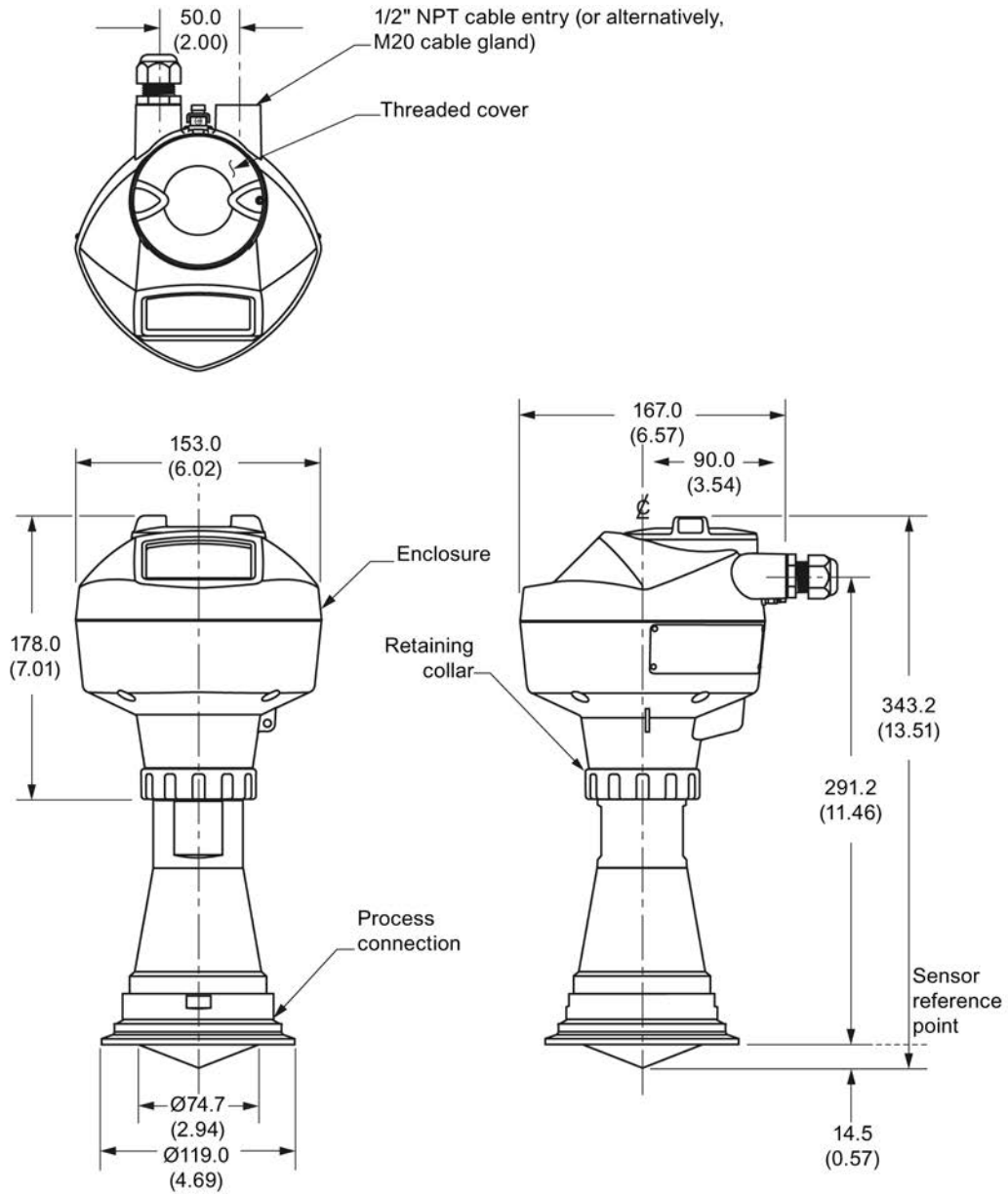

Dimensions in mm (inch)

12.10 Hygienic encapsulated antenna (DN 50 nozzle/ slotted nut to DIN 11851)

12.10 Hygienic encapsulated antenna (DN 50 nozzle/ slotted nut to DIN 11851)

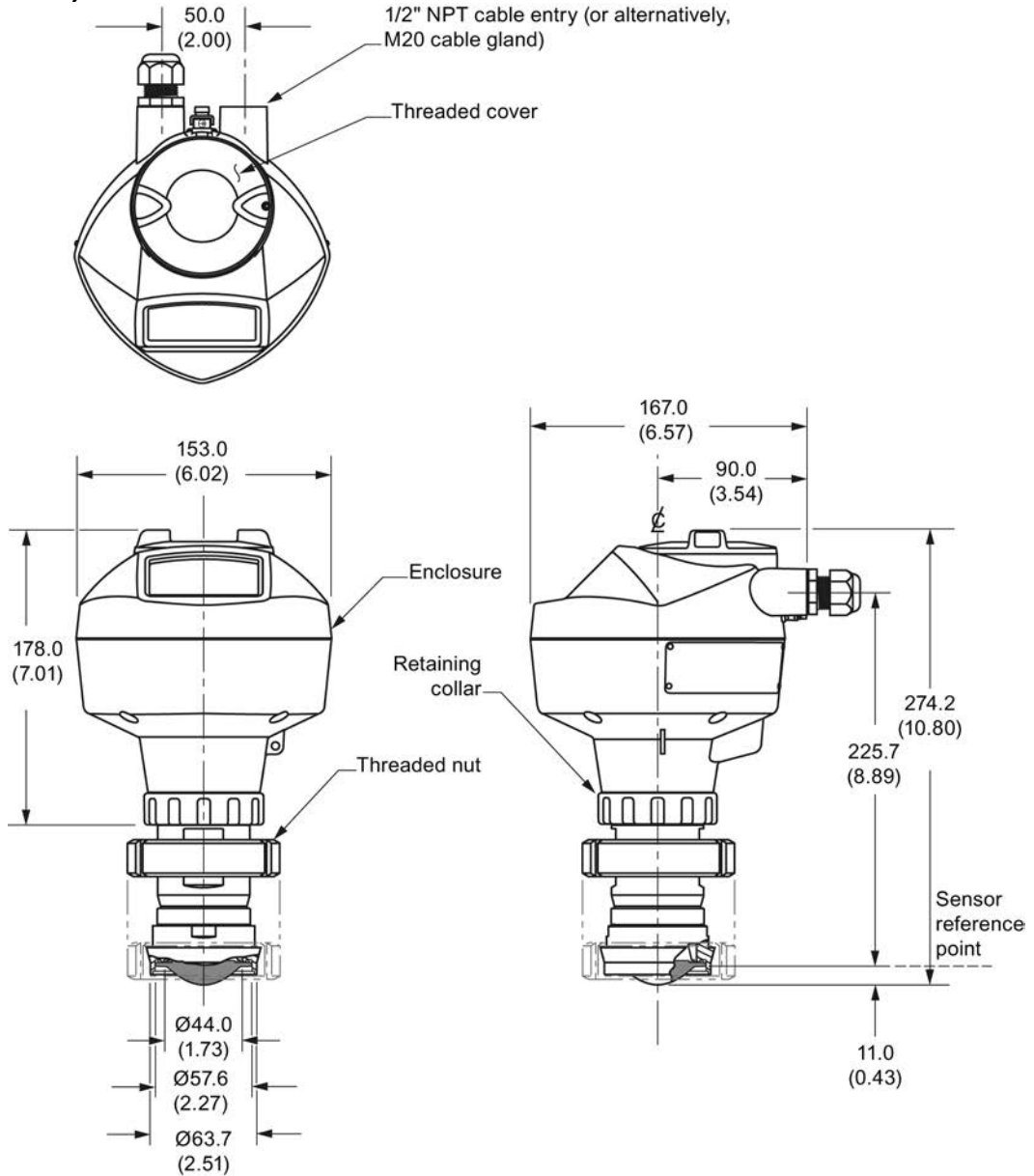

Dimensions in mm (inch)

Note

Cut out of process connection and placement of threaded nut are shown for illustration purposes only.

12.11 Hygienic encapsulated antenna (DN 80 nozzle/ slotted nut to DIN 11851)

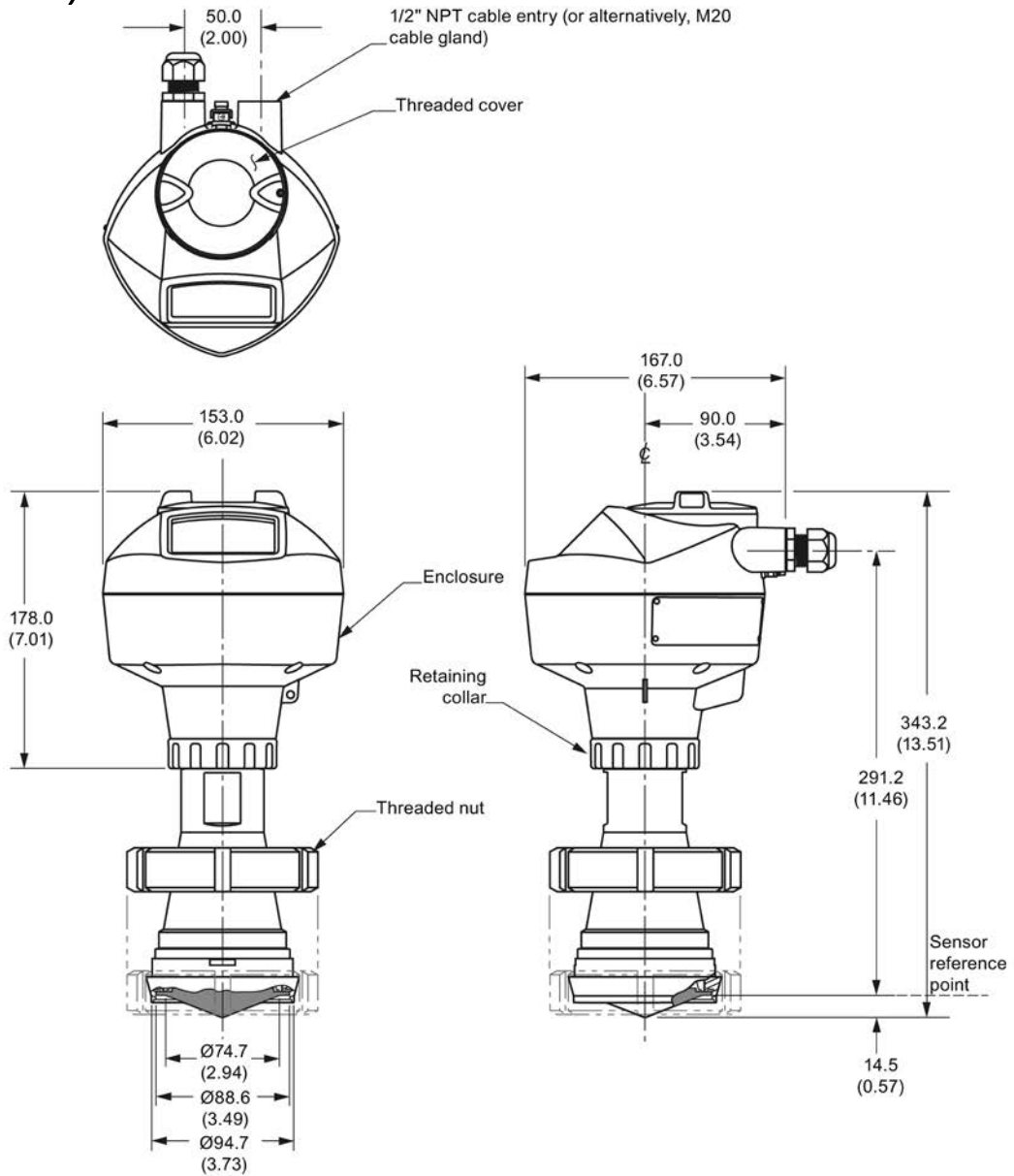

Dimensions in mm (inch)

Note

Cut out of process connection and placement of threaded nut are shown for illustration purposes only.

12.12 Hygienic encapsulated antenna (DN 100 nozzle/ slotted nut to DIN 11851)

12.12 Hygienic encapsulated antenna (DN 100 nozzle/ slotted nut to DIN 11851)

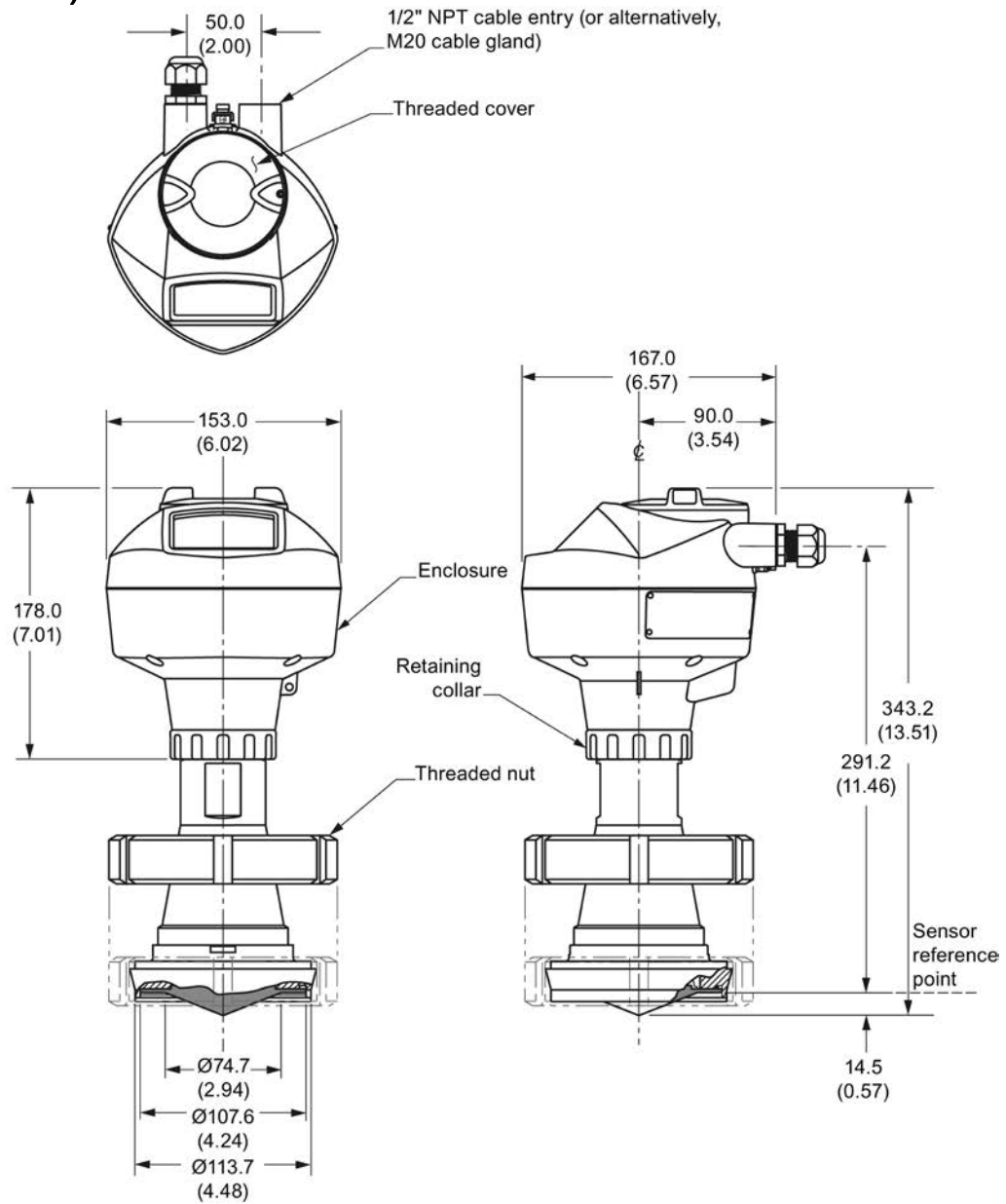

Dimensions in mm (inch)

Note

Cut out of process connection and placement of threaded nut are shown for illustration purposes only.

12.13 Hygienic encapsulated antenna (DN 50 aseptic slotted nut to DIN 11864-1)

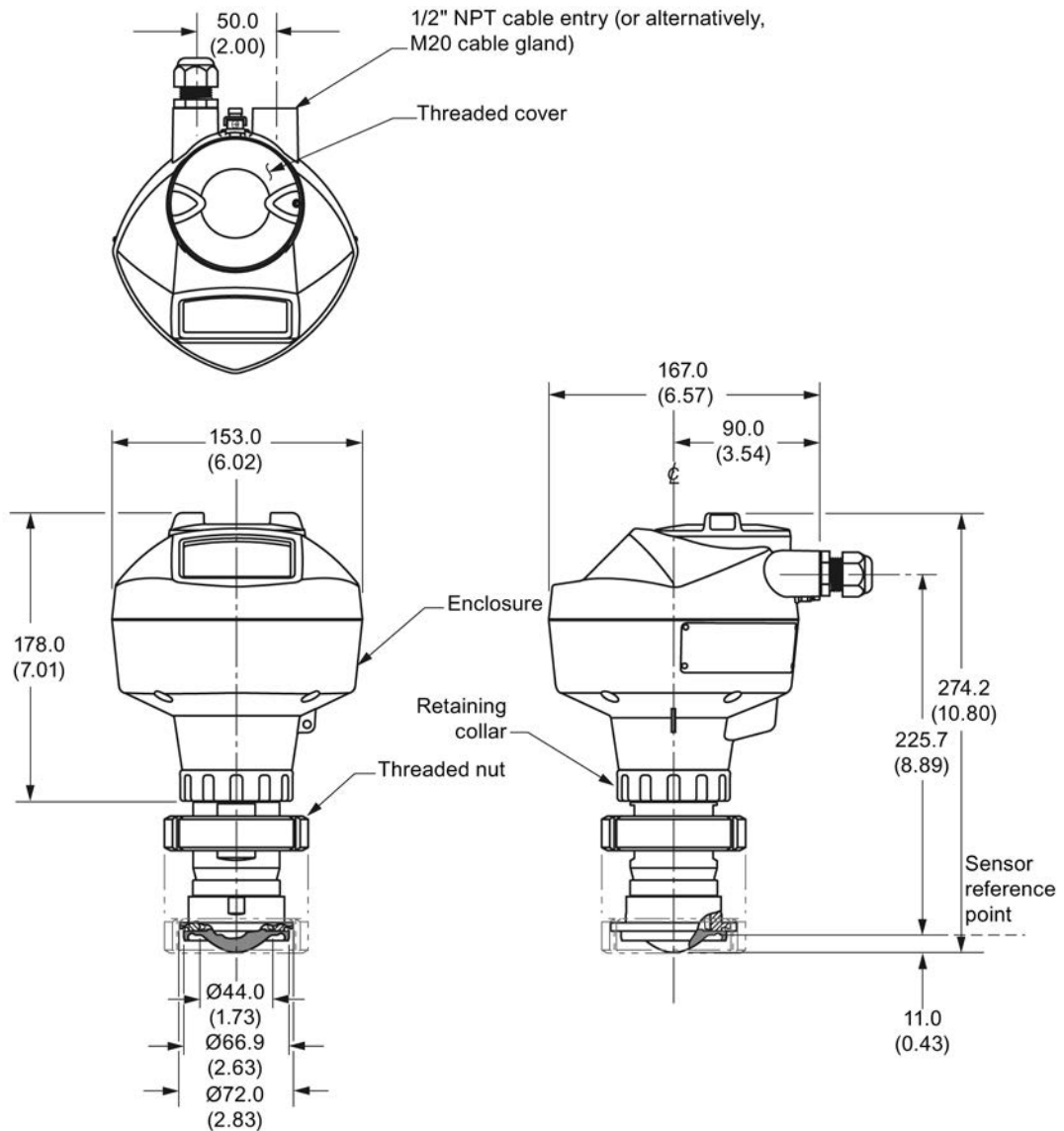

Dimensions in mm (inch)

Note

Cut out of process connection and placement of threaded nut are shown for illustration purposes only.

12.14 Hygienic encapsulated antenna (DN 80 aseptic slotted nut to DIN 11864-1)

12.14 Hygienic encapsulated antenna (DN 80 aseptic slotted nut to DIN 11864-1)

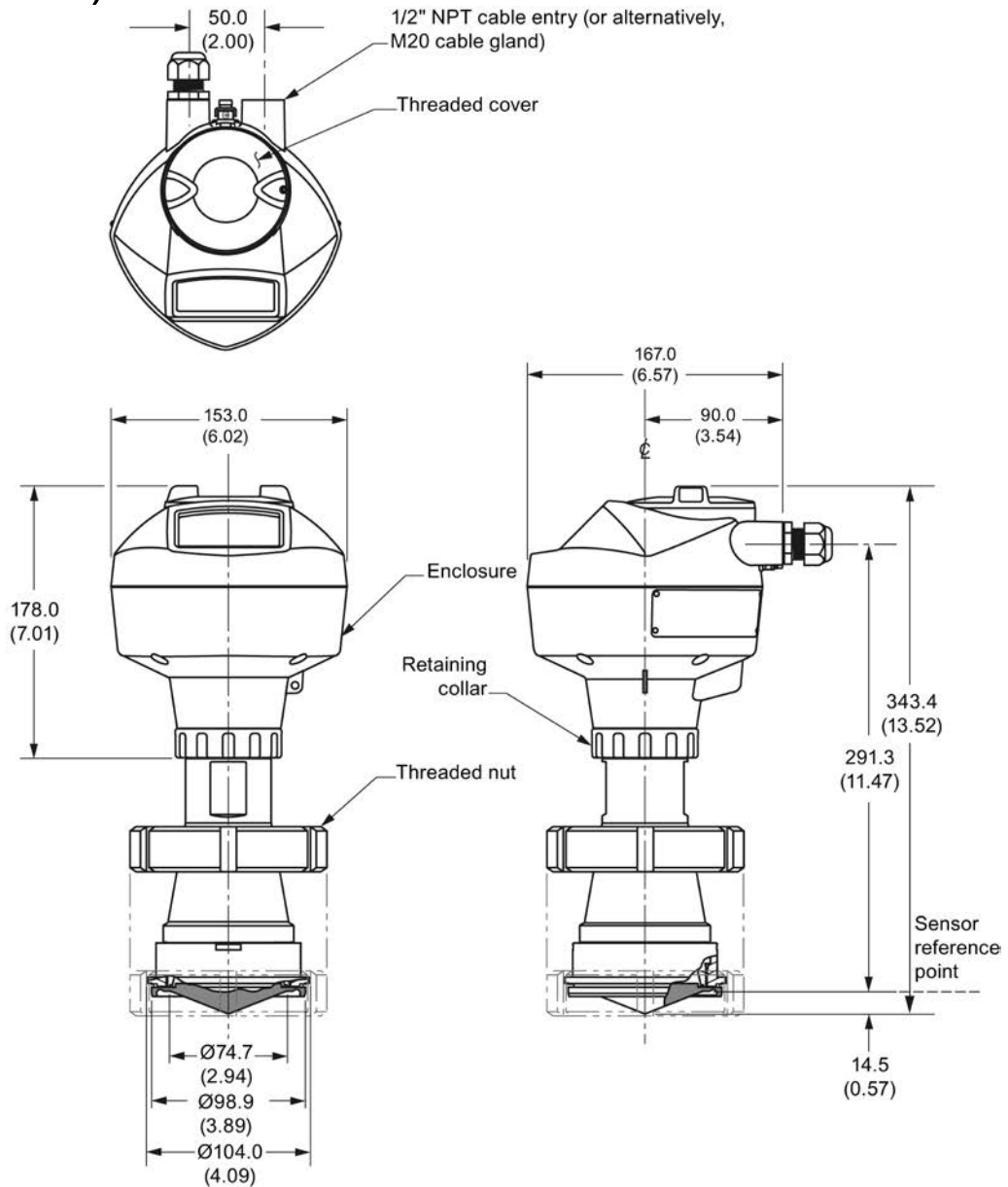

Dimensions in mm (inch)

Note

Cut out of process connection and placement of threaded nut are shown for illustration purposes only.

12.15 Hygienic encapsulated antenna (DN 100 aseptic slotted nut to DIN 11864-1)

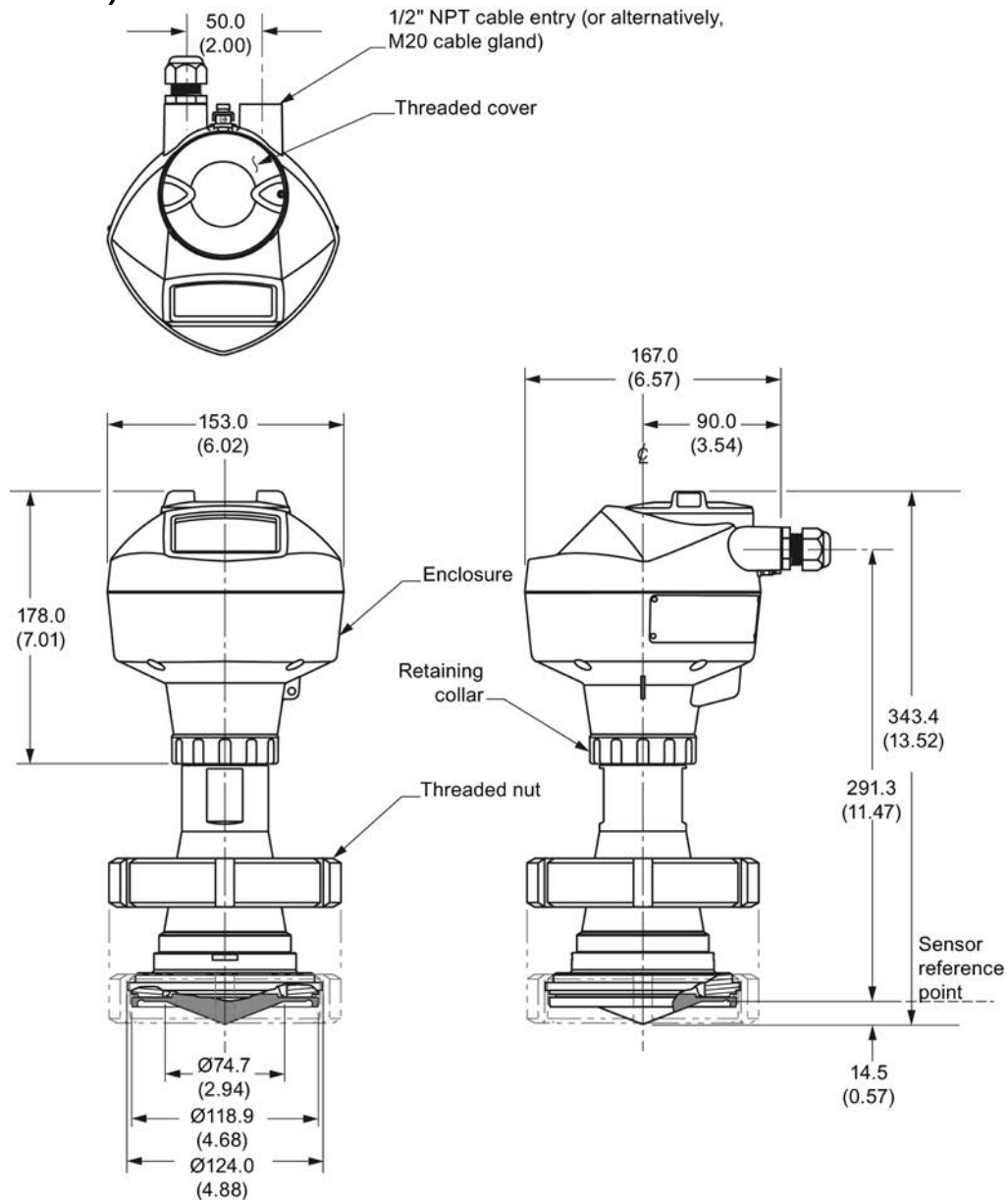

Dimensions in mm (inch)

Note

Cut out of process connection and placement of threaded nut are shown for illustration purposes only.

12.16 Hygienic encapsulated antenna (DN 50 aseptic flange to DIN 11864-2)

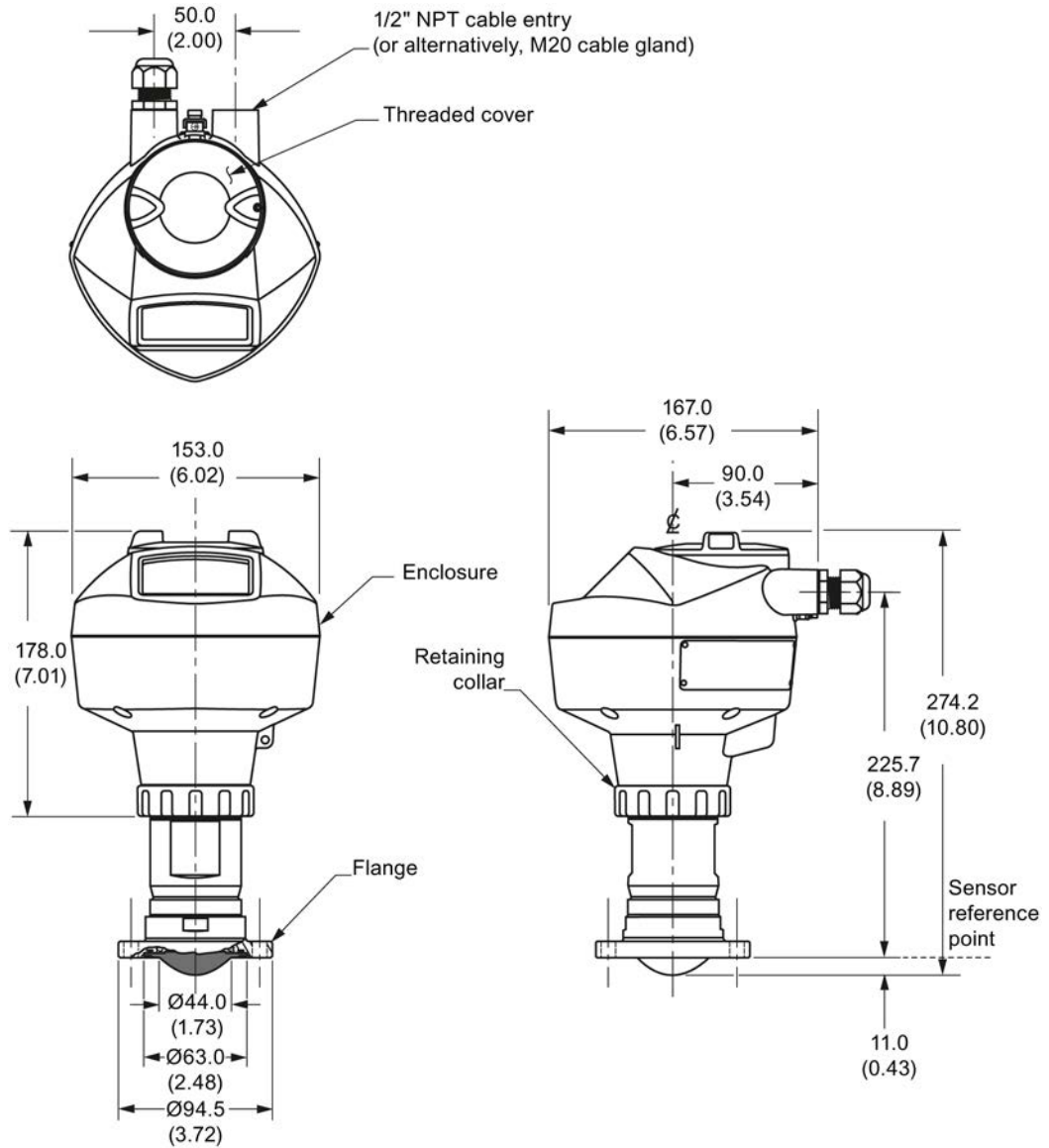

Dimensions in mm (inch)

Note

Cut out of process connection and flange are shown for illustration purposes only.

12.17 Hygienic encapsulated antenna (DN 80 aseptic flange to DIN 11864-2)

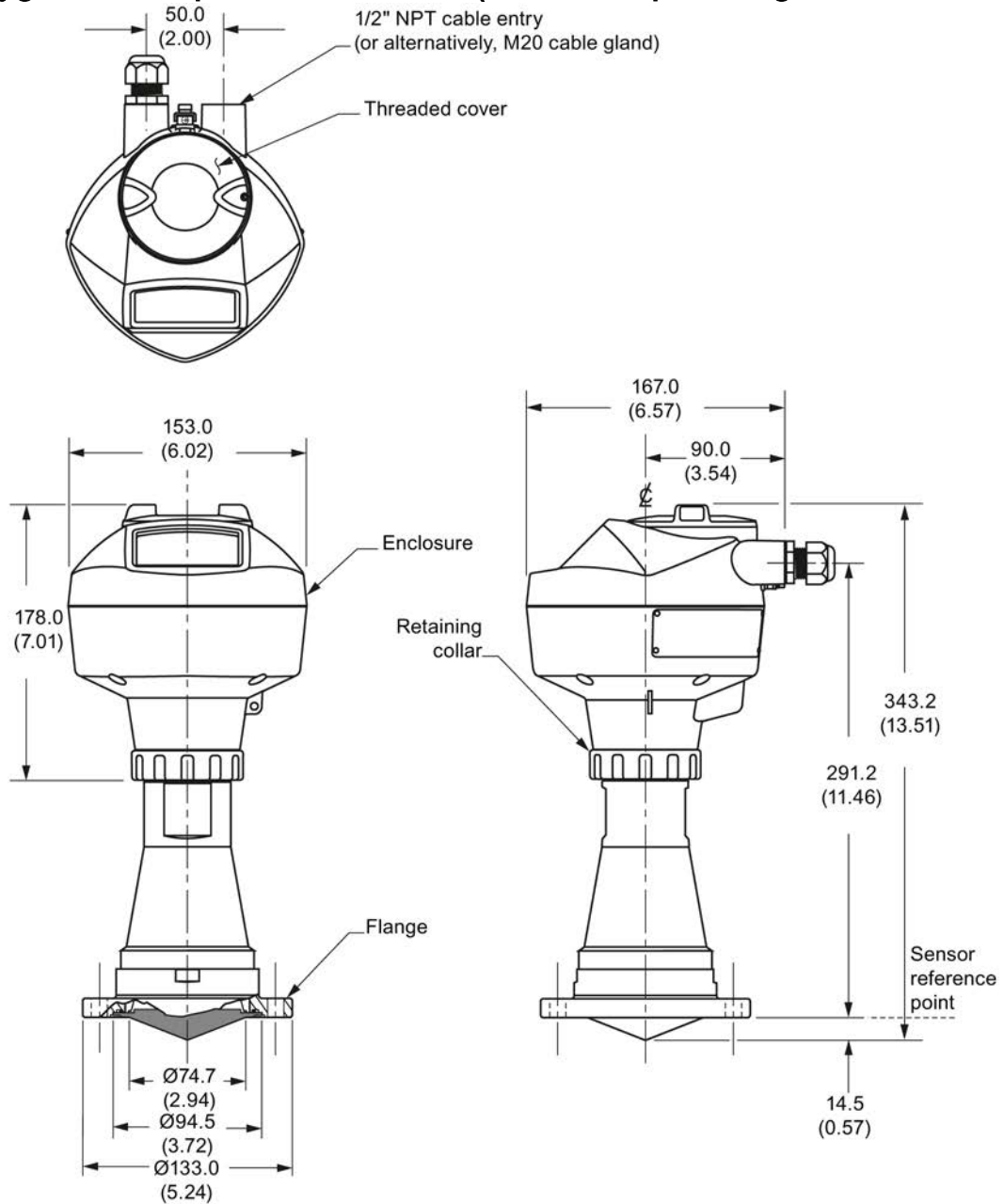

Dimensions in mm (inch)

Note

Cut out of process connection and flange are shown for illustration purposes only.

12.18 Hygienic encapsulated antenna (DN 100 aseptic flange to DIN 11864-2)

12.18 Hygienic encapsulated antenna (DN 100 aseptic flange to DIN 11864-2)

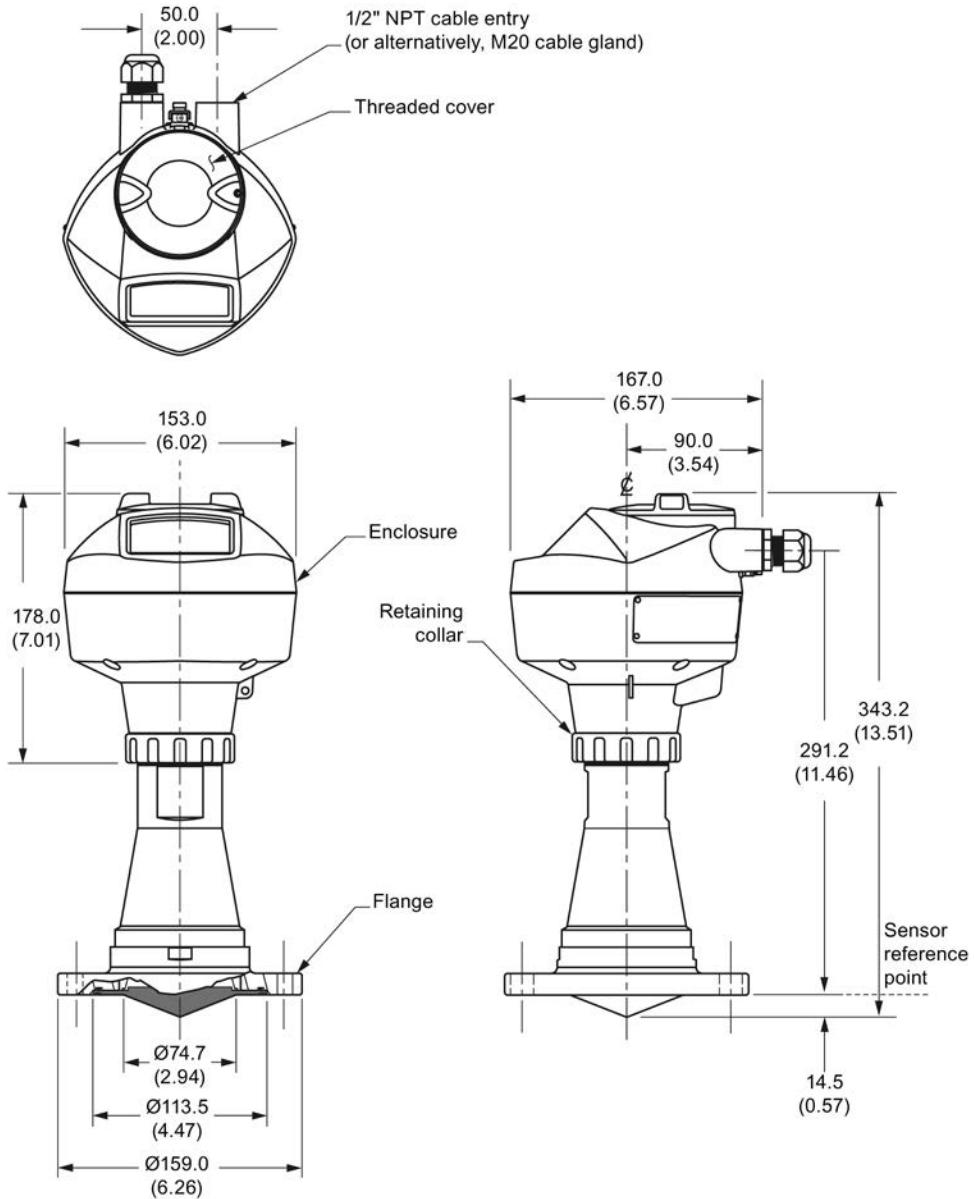

Dimensions in mm (inch)

Note

The cut out of the process connection and the flange are shown for illustration purposes only.

12.19 Hygienic encapsulated antenna (DN 50 aseptic clamp to DIN 11864-3)

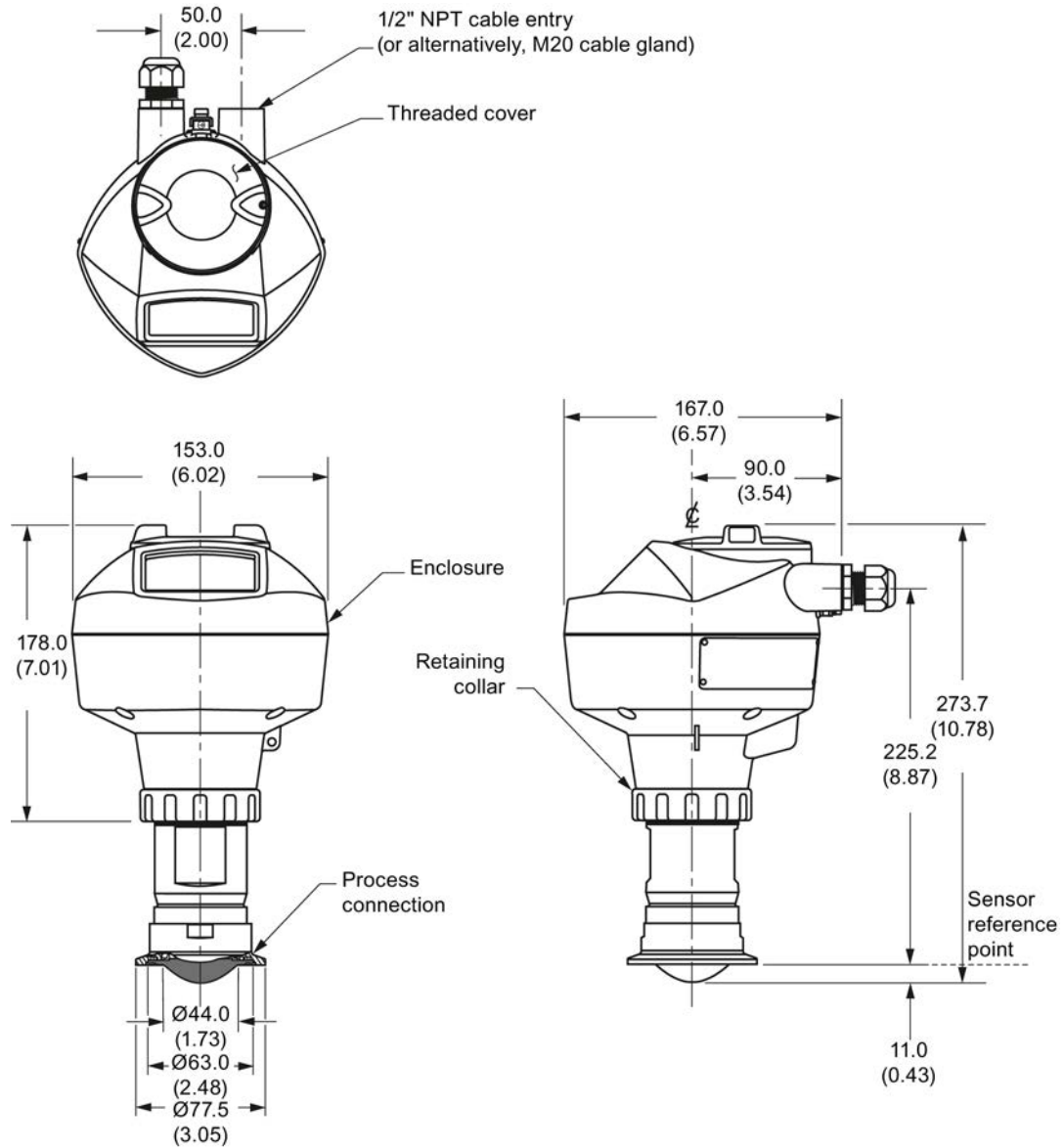

Dimensions in mm (inch)

Note

Cut out of process connection is shown for illustration purposes only.

12.20 Hygienic encapsulated antenna (DN 80 aseptic clamp to DIN 11864-3)

12.20 Hygienic encapsulated antenna (DN 80 aseptic clamp to DIN 11864-3)

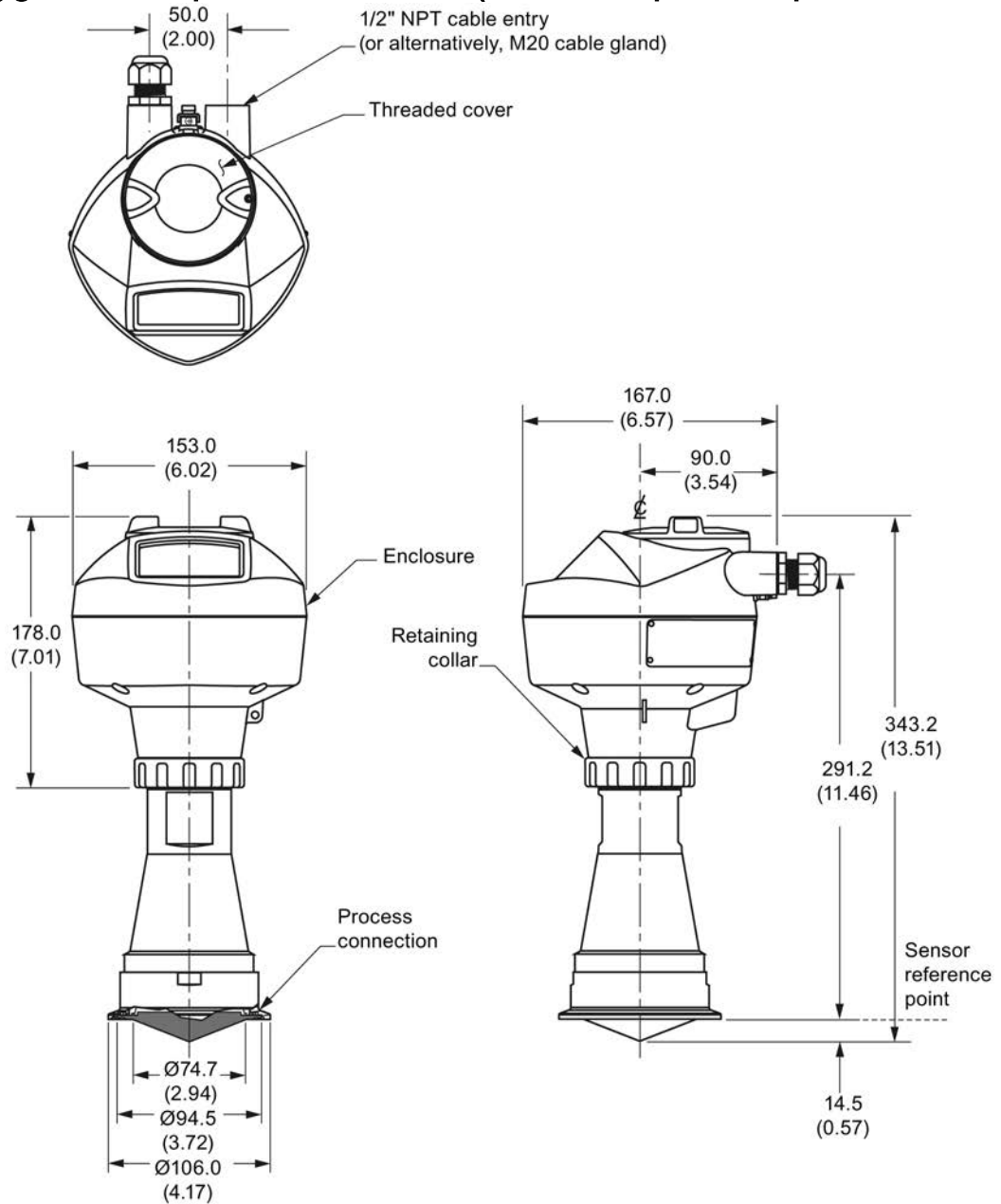

Dimensions in mm (inch)

Note

Cut out of process connection is shown for illustration purposes only.

12.21 Hygienic encapsulated antenna (DN 100 aseptic clamp to DIN 11864-3)

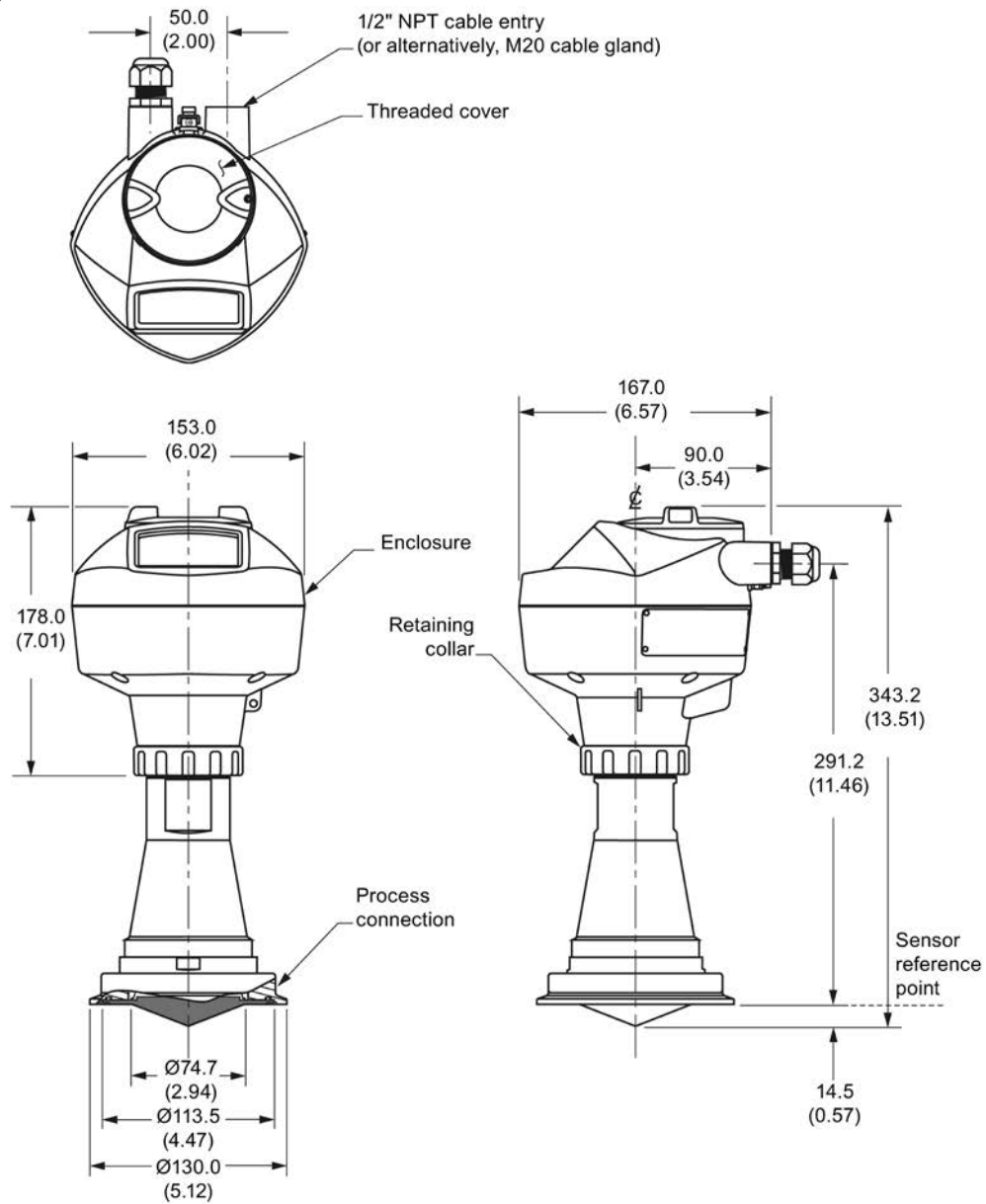

Dimensions in mm (inch)

Note

Cut out of process connection is shown for illustration purposes only.

12.22 Hygienic encapsulated antenna (Tuchenhagen Type N)

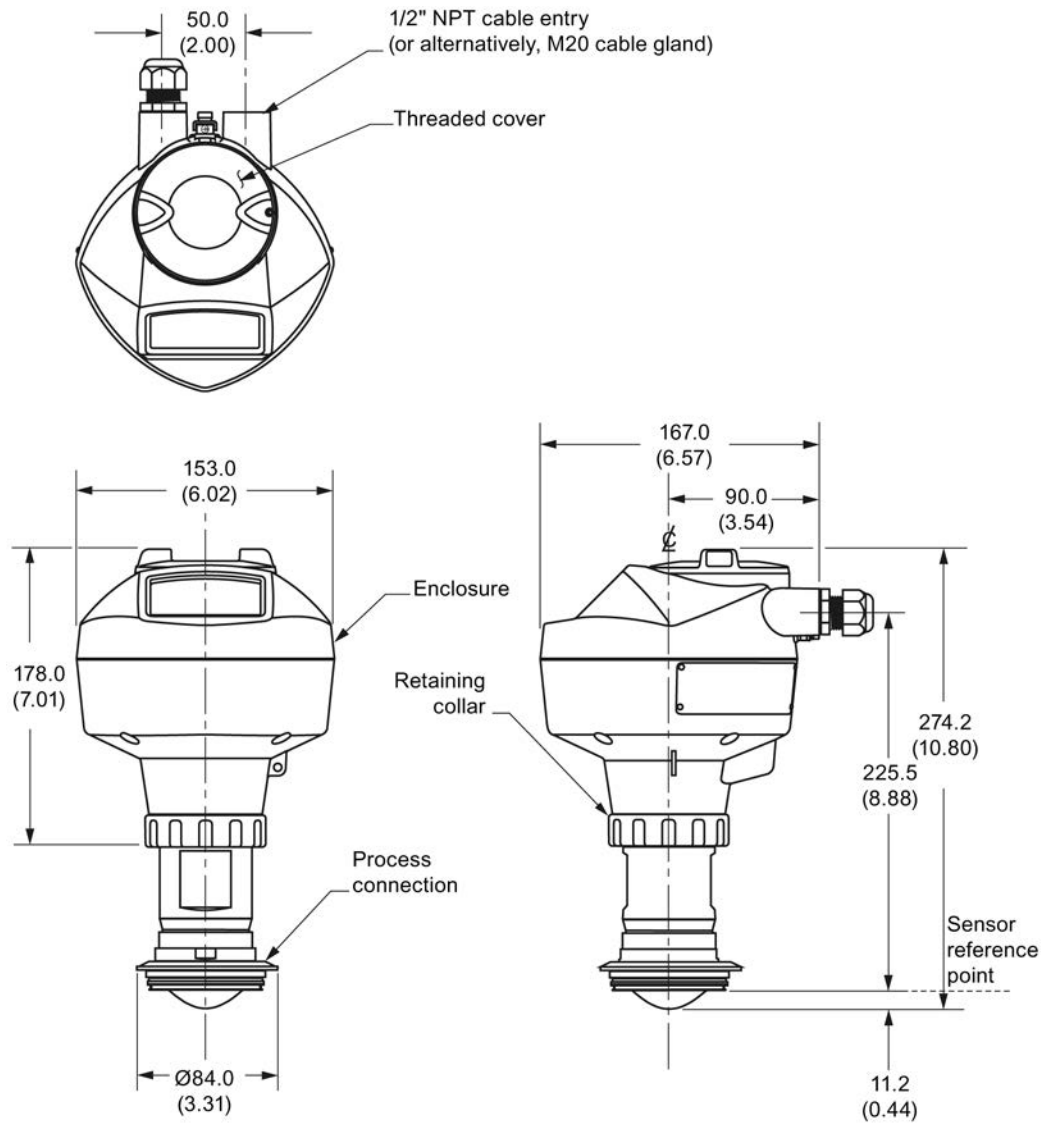

Dimensions in mm (inch)

12.23 Hygienic encapsulated antenna (Tuchenhagen Type F)

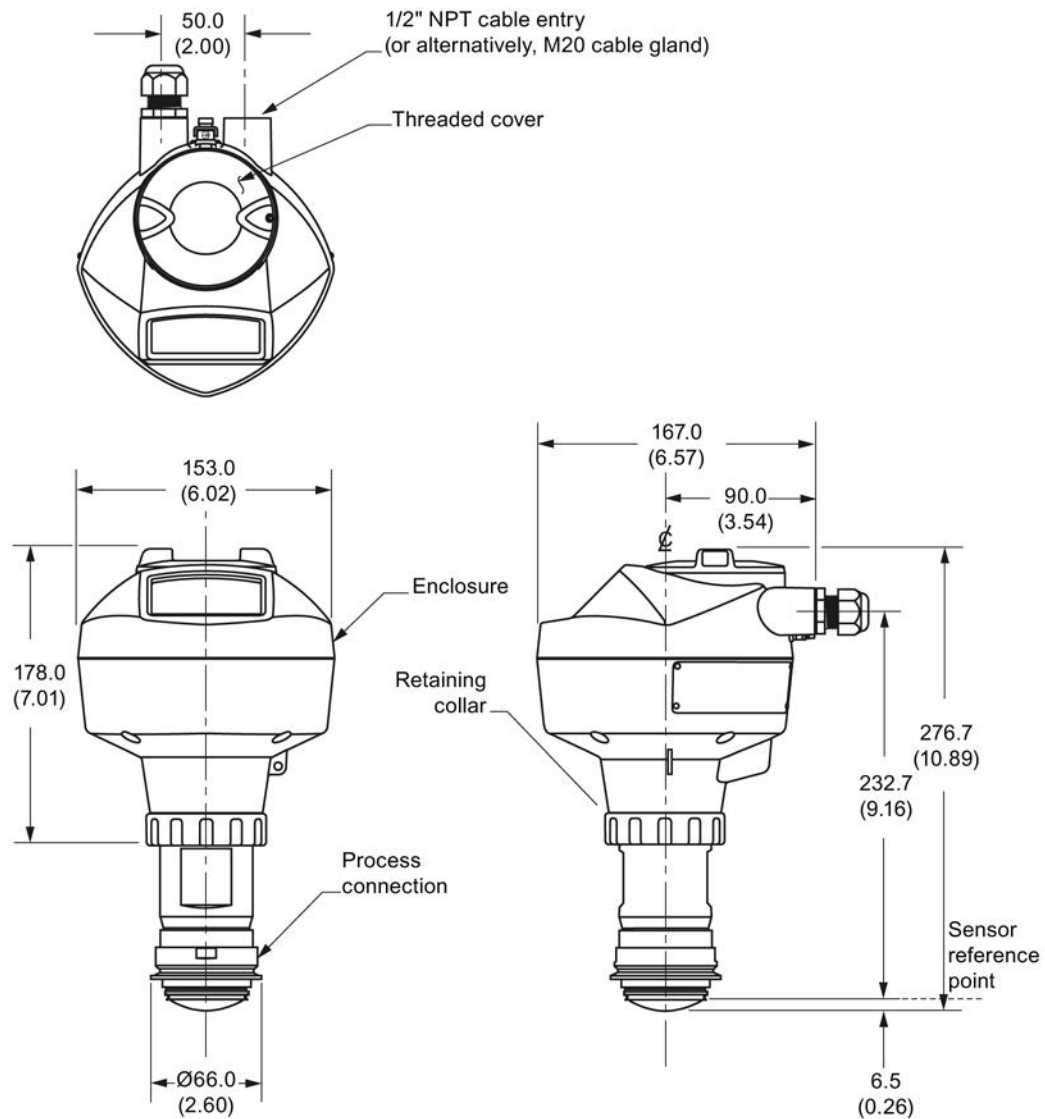

Dimensions in mm (inch)

12.24 Threaded PVDF antenna

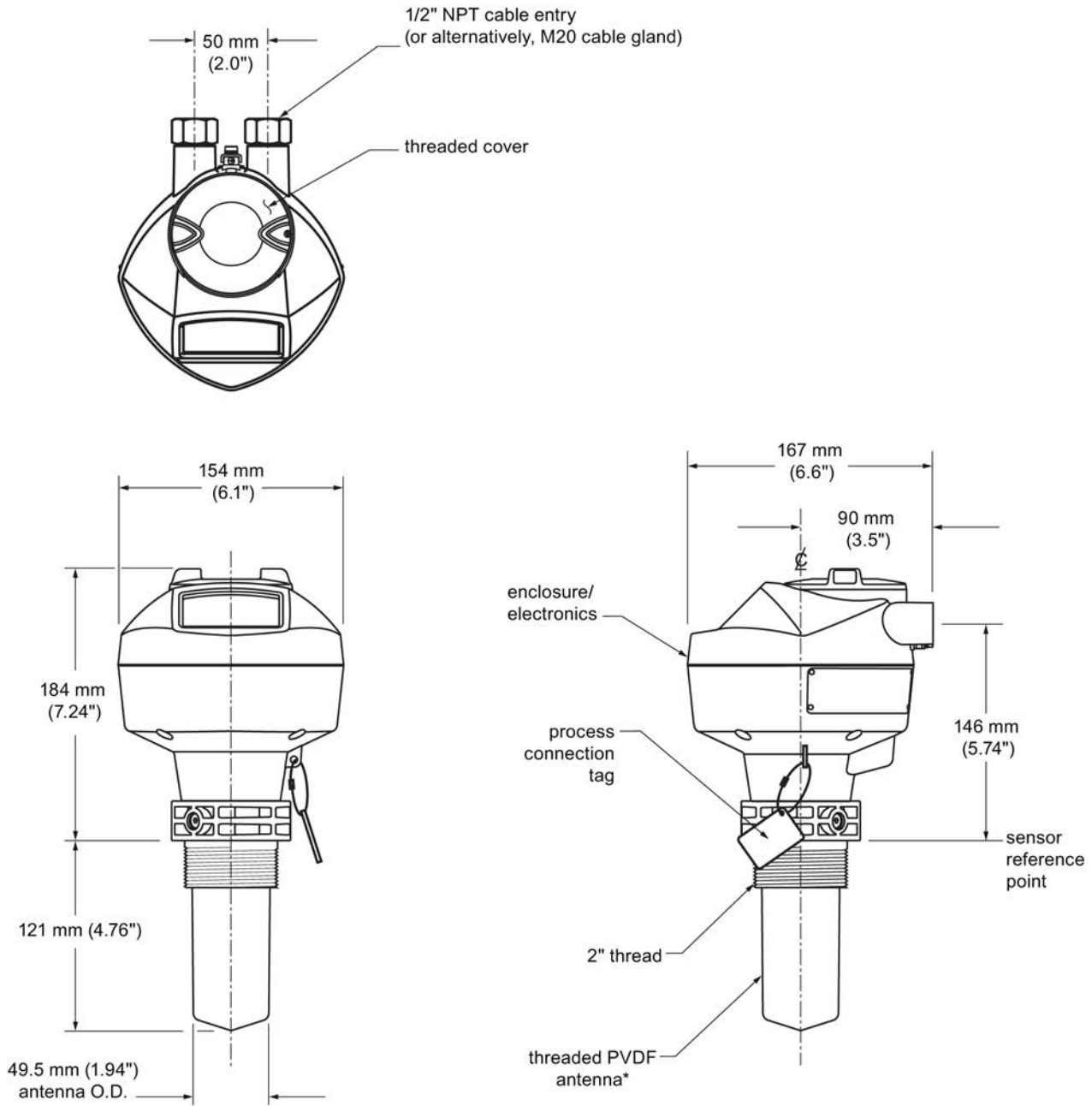

*The color of the antenna may vary.

Threaded PVDF antenna dimensions

Nominal antenna size	Antenna O.D.	Height to sensor reference point ^{a)}	Beam angle ^{b)}	Measurement range
50 mm (2")	49.5 mm (1.94")	121 mm (4.76")	19 degrees	10 m (32.8 ft) ^{c)}

a) Height from bottom of antenna to sensor reference point as shown: see dimension drawing.

b) -3dB in the direction of the polarization axis. See Polarization reference point (Page 31) for an illustration.

c) 20m when installed in stillpipe.

12.25 Threaded connection markings

With the exception of the threaded PVDF antenna, threaded connection markings are found on the flat face/faces of the process connection.

Serial number: a unique number allotted to each process connection, including the date of manufacture (MMDDYY) followed by a number from 001 to 999, (indicating the sequential unit produced).

12.26 Raised-Face flange per EN 1092-1 for flanged horn antenna

Stainless steel or optional alloy N06022/2.4602 (Hastelloy® C-22)

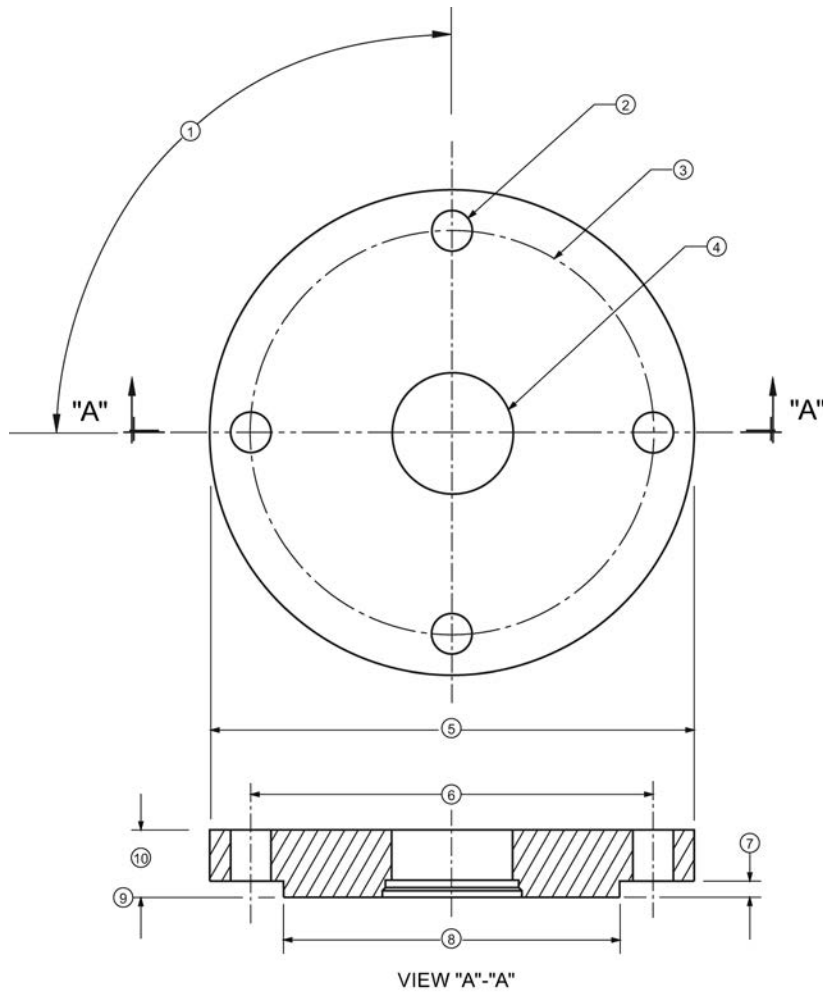

- | | | | |
|---|------------------------------|---|---------------------------|
| ① | angle of adjacent bolt holes | ⑥ | bolt hole circle diameter |
| ② | bolt hole diameter | ⑦ | facing height |
| ③ | bolt hole circle diameter | ⑧ | facing diameter |
| ④ | waveguide mounting hole | ⑨ | sensor reference point |
| ⑤ | Flange O.D. | ⑩ | thickness |

Raised-Face flange dimensions

Pipe size	Flange bolt hole pattern	⑤ Flange O.D. (mm)	③ Bolt hole circle Ø (mm)	② Bolt hole Ø (mm)	No. of bolts	① Angle of adjacent bolt holes	⑧ Facing Ø (mm)	⑩ Thickness (mm)
DN50	PN10/PN16	165	125	18	4	90	102	18
DN80	PN10/PN16	200	160	18	8	45	138	20
DN100	PN10/PN16	220	180	18	8	45	158	20
DN150	PN10/PN16	285	240	22	8	45	212	22
DN50	PN25/PN40	165	160	18	4	90	138	20
DN80	PN25/PN40	200	160	18	8	45	138	24
DN100	PN25/PN40	235	190	22	8	45	162	24
DN150	PN25/PN40	300	250	26	8	45	218	28

Raised-Face flange markings

Blind Flange Markings (Optional Manufacturer's Logo [optional]; Flange Standard; Nominal Size; Material; Heat Code)	Machining Identification			Welded Assembly Identification ^{a)}		
	Serial no.	Logo	Flange series	Flange series	Heat Code no.	Facing
Manufacturer's logo; EN 1092-1 05 'B1'; 'DN50' 'PN16' '1.4404 or 1.4435' A1B2C3	mmddyxx xx		xxxxx	xxxxx	A1B2C3	RF

^{a)} When flange material is alloy N06022/2.4602, additional material and heat code identification is provided.

The flange markings are located around the outside edge of the flange.

Serial number: a unique number allotted to each flange, including the date of manufacture (MMDDYY) followed by a number from 001 to 999 (indicating the sequential unit produced).

Flange series: the Siemens Milltronics drawing identification.

Heat code: a flange material batch code identification.

12.27 Raised-Face flange per EN 1092-1 for flanged encapsulated antenna

Stainless steel

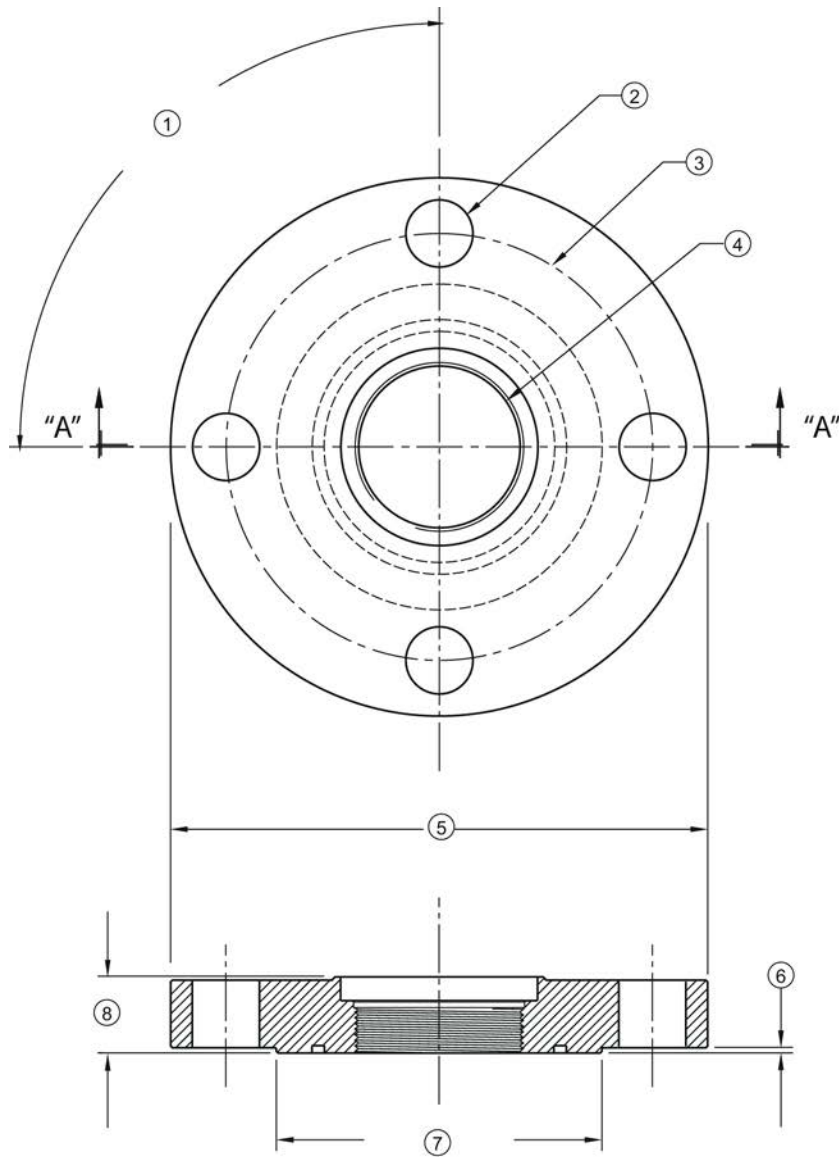

VIEW "A"- "A"

- | | | | |
|---|------------------------------|---|------------------|
| ① | angle of adjacent bolt holes | ⑤ | flange O.D. |
| ② | bolt hole diameter | ⑥ | facing height |
| ③ | bolt hole circle diameter | ⑦ | facing diameter |
| ④ | antenna | ⑧ | flange thickness |

Raised-Face flange dimensions

Pipe size	Flange class	⑤ Flange O.D. [mm (inch)]	③ Bolt hole circle Ø [mm (inch)]	② Bolt hole Ø [mm (inch)]	No. of bolt holes	① Angle of adjacent bolt holes	⑦ Facing Ø [mm (inch)]	⑨ Flange thickness [mm (inch)]	⑥ Flange facing thickness [mm (inch)]
2"	150 LB	152 (5.98)	120.7 (4.75)	19 (0.75)	4	90	92.1 (3.63)	20.6 (0.81)	1.5 (0.06)
3"		190 (7.48)	152.4 (6.00)				127 (5.00)	25.9 (1.02)	2 (0.08)
4"		230 (9.06)	190.5 (7.50)		8	45	157.2 (6.19)		2 (0.08)
6"		280 (11.02)	241.3 (9.50)	22.2 (0.87)			215.9 (8.50)	26.9 (1.06)	1.5 (0.06)
DN50	PN10/16	155 (6.10)	125 (4.92)	18 (0.71)	4	90	102 (4.02)	18 (0.71)	2 (0.08)
DN80		200 (7.87)	160 (6.30)		8	45	138 (5.43)	20 (0.79)	2 (0.08)
DN100		220 (8.66)	180 (7.09)				158 (6.22)		2 (0.08)
DN150		285 (11.22)	240 (9.45)	22 (0.87)			212 (8.35)	22 (0.87)	2 (0.08)
50A	10K	155 (6.10)	120 (4.72)	19 (0.75)	4	90	96 (3.78)	16 (0.63)	2 (0.08)
80A		185 (7.28)	150 (5.91)		8	45	126 (4.96)	18 (0.71)	2 (0.08)
100A		210 (8.27)	175 (6.89)				151 (5.94)		2 (0.08)
150A		280 (11.02)	240 (9.45)	23 (0.91)			212 (8.35)	22 (0.87)	2 (0.08)

12.27 Raised-Face flange per EN 1092-1 for flanged encapsulated antenna

Raised-Face flange markings

Blind Flange Markings (Optional Manufacturer's Logo [optional]; Flange Standard; Nominal Size; Material; Heat Code)	Machining Identification			Welded Assembly Identification		
	Serial no.	Logo	Flange series	Flange series	Heat Code no.	Facing
Manufacturer's logo; EN 1092-1 05 'B1'; 'DN50' 'PN16' '1.4404 or 1.4435' A1B2C3	mmddyxx xx		xxxxx	xxxxx	A1B2C3	RF

The flange markings are located around the outside edge of the flange.

Serial number: a unique number allotted to each flange, including the date of manufacture (MMDDYY) followed by a number from 001 to 999 (indicating the sequential unit produced).

Flange series: the Siemens Milltronics drawing identification.

Heat code: a flange material batch code identification.

12.28 Flat-Face flange

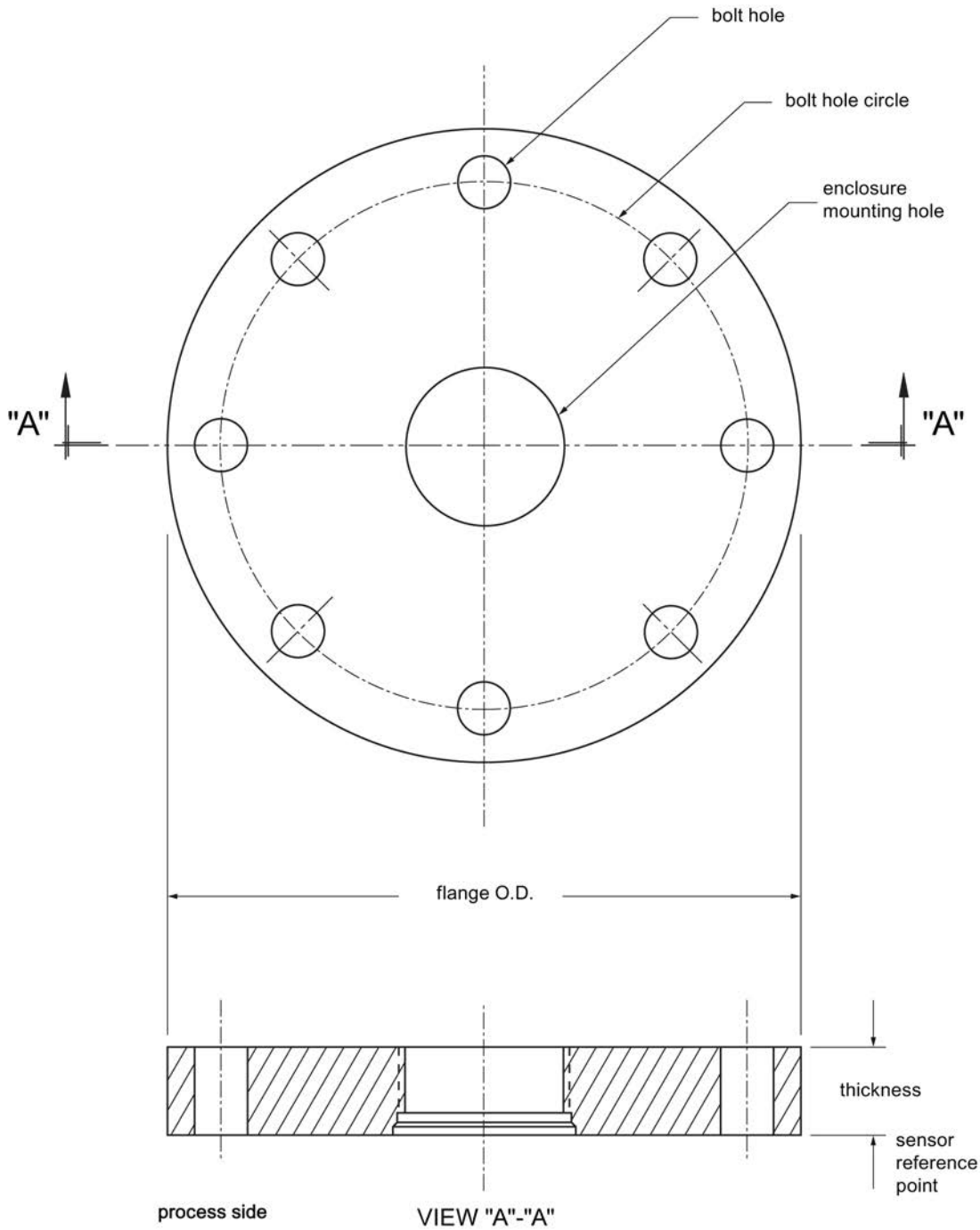

Flat-Face flange dimensions

Flange size ^{a)}	Flange class	Flange O.D.	Bolt hole circle Ø	Bolt hole Ø	No. of bolt holes	Thickness
2"	ASME 150 lb	6.0"	4.75"	0.75"	4	0.88"
3"	ASME 150 lb	7.5"	6.0"	0.75"	4	0.96"
4"	ASME 150 lb	9.0"	7.50"	0.75"	8	1.25"
2"	ASME 300 lb	6.50"	5.00"	0.75"	8	1.12"
3"	ASME 300 lb	8.25"	6.62"	0.88"	8	1.38"
4"	ASME 300 lb	10.00"	7.88"	0.88"	8	1.50"
DN50	EN PN16	165 mm	125 mm	18 mm	4	24.4 mm
DN80	EN PN16	200 mm	160 mm	18 mm	8	31.8 mm
DN100	EN PN16	220 mm	180 mm	18 mm	8	31.8 mm
DN50	EN PN40	165 mm	125 mm	18 mm	4	25.4 mm
DN80	EN PN40	200 mm	160 mm	18 mm	8	31.8 mm
DN100	EN PN40	235 mm	190 mm	22 mm	8	38.1 mm
50A	JIS 10K	155 mm	120 mm	19 mm	4	23.8 mm
80A	JIS 10K	185 mm	150 mm	19 mm	8	24.4 mm
100A	JIS 10K	210 mm	175 mm	19 mm	8	28.5 mm

^{a)} A 2" flange is designed to fit a 2" pipe: for actual flange dimensions see Flange O.D. Flange markings located around the outside edge of the flat faced flange identify the flange assembly on which the device is mounted.

Flat-Face flange markings

Flat Face Flange Identification					Welded Assembly Identification		
Serial No.	Logo	Flange series		Material	Heat code	Flange series	Heat code no.
		Series	Nominal size				
MMDDYYXXX		25556	2 150 DN80 PN16	316L/ 1.4404 or 316L/ 1.4435	A1B2C3	25546	A1B2C3

Serial number: A unique number allotted to each flange, including the date of manufacture (MMDDYY) followed by a number from 001 to 999 (indicating the sequential unit produced).

Flange series: The Siemens Milltronics drawing identification.

- Nominal size:** The flange size followed by the hole pattern for a particular flange class. For example:
- A 2 inch ASME B16.5 150 lb class flange (North America)
 - A DN80 EN 1092-1 PN16 class flange (Europe)
- Material:** The basic flange material (AISI or EU material designation). North American material codes are followed by European ones. For example, material designation 316L/1.4404.
- Heat code:** A flange material batch code identification.

12.29 Aseptic/hygienic flange DN50, DN80, DN100 for DIN 11864-2

Aseptic/hygienic flange DN50

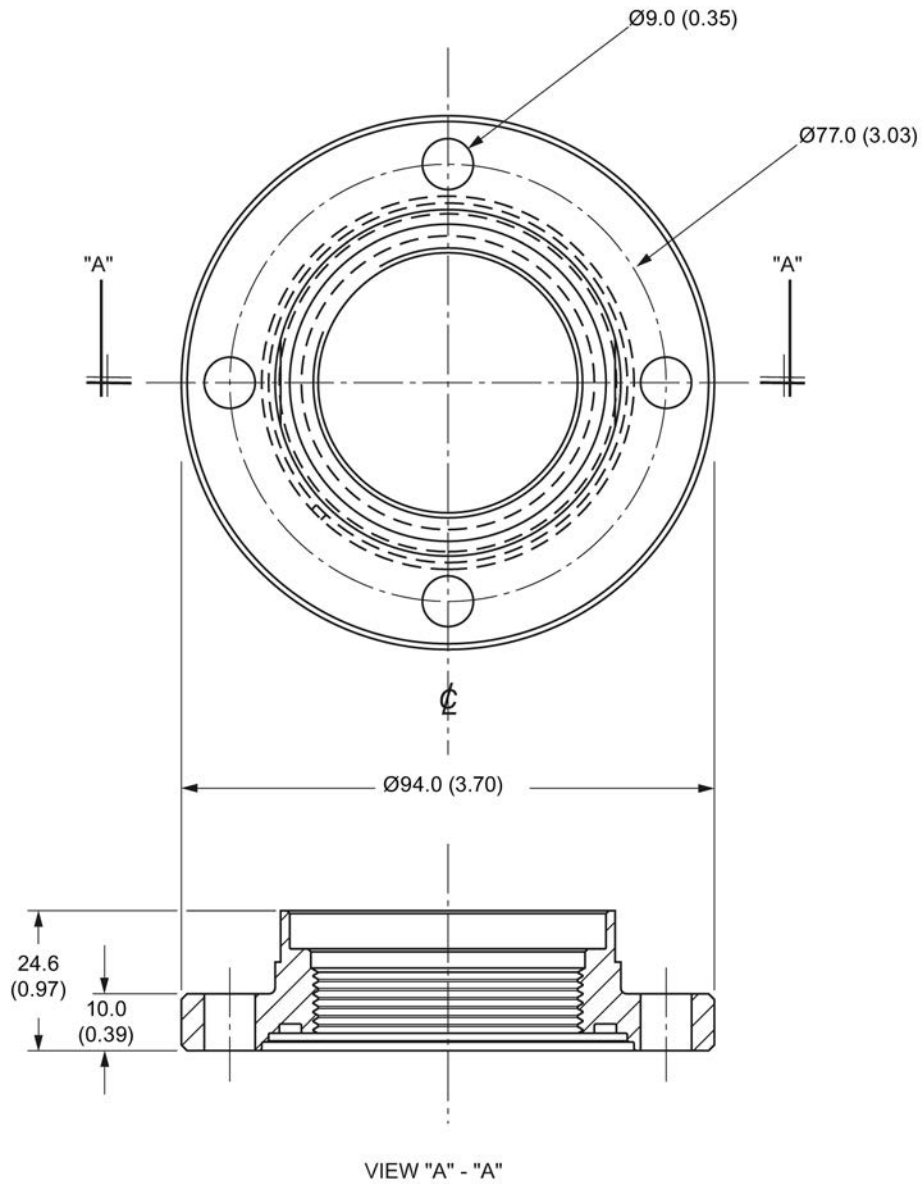

Aseptic/hygienic flange DN80

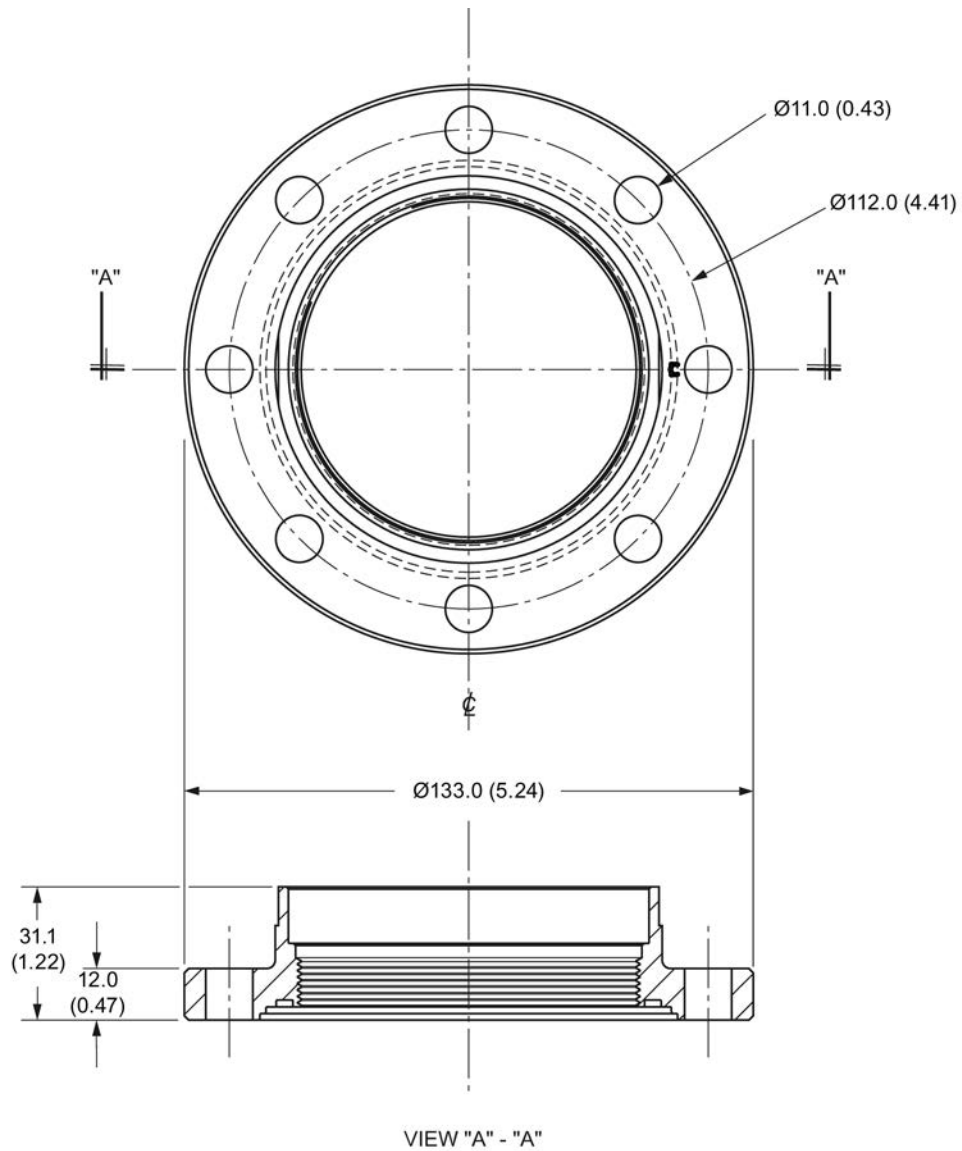

Dimensions in mm (inch)

Aseptic/hygienic flange DN100

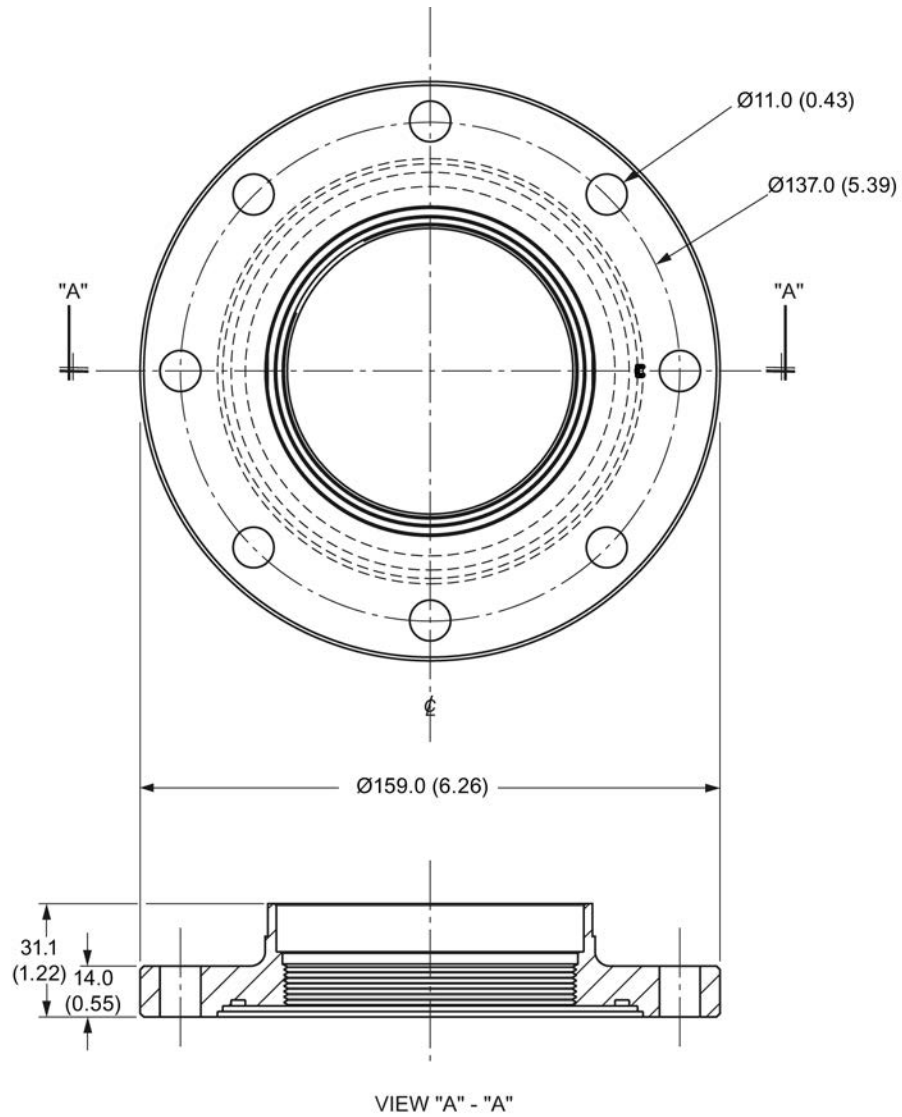

Dimensions in mm (inch)

12.30 Process connection tag (pressure rated versions)

For pressure-rated versions only, the process connection label lists the following information:

Process connection tag (pressure rated versions)

Item	Sample Text	Comments/Explanation
SERIAL #	GYZ / 00000000	Pressure Boundary Assembly
NOMINAL PIPE SIZE (DN)	4 INCH / 100mm	Nominal Pipe Size
INSTRUMENT MAWP (PS)	11.0 BAR	Maximum Allowable Working Pressure at Design Temperature for the device
DESIGN TEMP. (TS)	200 °C	Maximum Allowable Working Temperature
MINIMUM PROCESS	15.9 BAR AT 40 °C	Minimum Wetted Process Conditions
TEST PRESSURE (PT)	22.7 BAR	Production Test Pressure
TEST DATE	10/11/11	Date of Pressure Test (Year/Month/Day)
CONNECTION SERIES	ASME B16.5	Flange Series: dimensional pattern based on ASME B16.5 flange standards
PROCESS SERIES	25546	Pressure Tag Family Series
WETTED NON-METALLICS	TFM	Antenna Emitter
WETTED METALLICS	316L	Process Connection Material(s)
WETTED SEALS	FKM	Seal Material(s)

- Minimum Wetted Process Conditions: the minimum pressure and temperature to which the device assembly may be exposed in the process, and continue to provide a pressure-retaining function.
- Pressure Tag Family Series: the identification number used to indicate specific process connection information relating to operating conditions.
- For Flanged encapsulated antenna: this information is laser-etched on antenna body

BACK FACE	
Sample Text	Comments/Explanation
CRN 0Fxxxx.5	Canadian Registration Number (CRN)

A

Appendix A: Technical reference

Note

Where a number follows the parameter name [for example, **Master Reset (4.1.)**] this is the parameter access number via the handheld programmer. See Parameter Reference (Page 143) for a complete list of parameters.

A.1 Principles of operation

SITRANS LR250 is a 2-wire 25 GHz pulse radar level transmitter for continuous monitoring of liquids and slurries. (The microwave output level is significantly less than that emitted from cellular phones.) Radar level measurement uses the time of flight principle to determine distance to a material surface. The device transmits a signal and waits for the return echo. The transit time is directly proportional to the distance from the material.

Pulse radar uses polarized electromagnetic waves. Microwave pulses are emitted from the antenna at a fixed repetition rate, and reflect off the interface between two materials with different dielectric constants (the atmosphere and the material being monitored).

Electromagnetic wave propagation is virtually unaffected by temperature or pressure changes, or by changes in the vapor levels inside a vessel. Electromagnetic waves are not attenuated by dust.

SITRANS LR250 consists of an enclosed electronic circuit coupled to an antenna and process connection. The electronic circuit generates a radar signal (25 GHz) that is directed to the antenna.

The signal is emitted from the antenna, and the reflected echoes are digitally converted to an echo profile. The profile is analyzed to determine the distance from the material surface to the sensor reference point. See Dimension drawings (Page 221). This distance is used as a basis for the display of material level and mA output.

A.2 Echo processing

A.2.1 Process Intelligence

The signal processing technology embedded in Siemens radar level devices is known as **Process Intelligence**.

Process intelligence provides high measurement reliability regardless of the dynamically changing conditions within the vessel being monitored. The embedded Process Intelligence dynamically adjusts to the constantly changing material surfaces within these vessels.

Process Intelligence is able to differentiate between the true microwave reflections from the surface of the material and unwanted reflections being returned from obstructions such as seam welds or supports within a vessel. The result is repeatable, fast and reliable measurement. This technology was developed as result of field data gained over some twenty years from more than 1,000,000 installations in many industries around the world.

Higher order mathematical techniques and algorithms are used to provide intelligent processing of microwave reflection profiles. This "knowledge based" technique produces superior performance and reliability.

A.2.2 Echo Selection

Time Varying Threshold (TVT)

A Time Varying Threshold (TVT) hovers above the echo profile to screen out unwanted reflections (false echoes).

In most cases the material echo is the only one which rises above the default TVT.

In a vessel with obstructions, a false echo may occur. See Auto False Echo Suppression (Page 271) for more details.

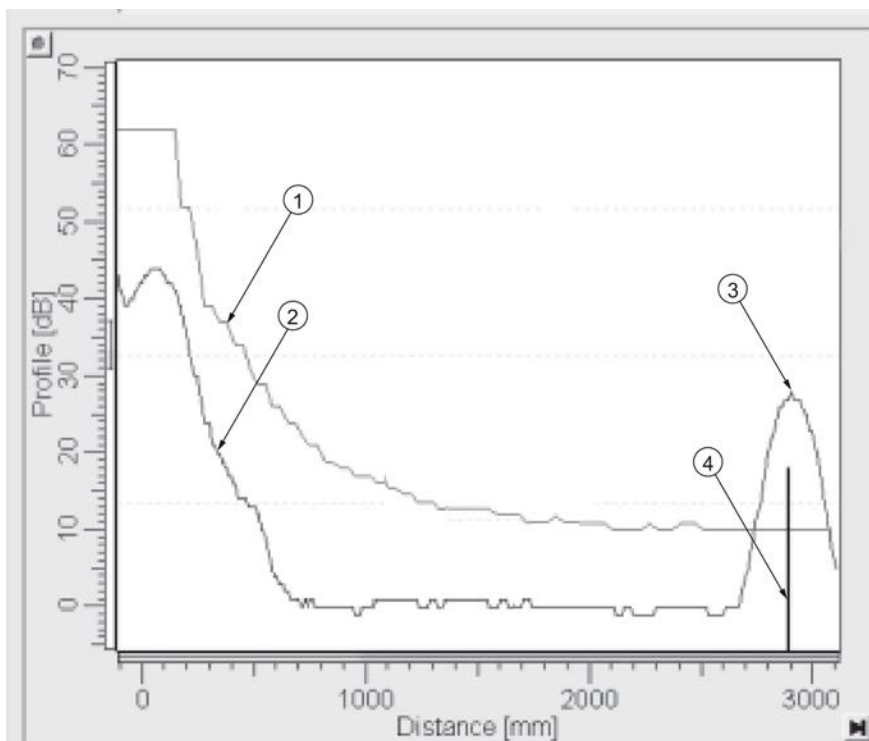

- ① default TVT
- ② echo profile
- ③ material level
- ④ echo marker

The device characterizes all echoes that rise above the TVT as potential good echoes. Each peak is assigned a rating based on its strength, area, height above the TVT, and reliability, amongst other characteristics.

Algorithm (2.5.7.1.)

The true echo is selected based on the setting for the Echo selection algorithm. Options are **true First Echo**, **Largest Echo**, or **best of First and Largest**.

Position Detect (2.5.7.2.)

The echo position detection algorithm determines which point on the echo will be used to calculate the precise time of flight, and calculates the range using the calibrated propagation velocity [see **Propagation Factor (2.5.3.)** for values]. There are three options:

- **Center**
- **Hybrid** (Center and CLEF)
- **CLEF** (Constrained Leading Edge Fit)

Center

Uses center of the echo.

Hybrid

Uses the Center algorithm for the top part of the vessel, and the CLEF algorithm for the part nearest the vessel bottom, according to the setting for **CLEF range**.

CLEF (Constrained Leading Edge Fit)

- Uses the leading edge of the echo.
- Is used mainly to process the echo from materials with a low dK value.

In an almost empty flat-bottomed vessel, a low dK material may reflect an echo weaker than the echo from the vessel bottom. The echo profile shows these echoes merging. The device may then report a material level equal to or lower than empty.

The CLEF algorithm enables the device to report the level correctly.

Example: CLEF off: Position set to Hybrid

Vessel height: 1.5 m; CLEF range set to 0 (Center algorithm gives the same result.)

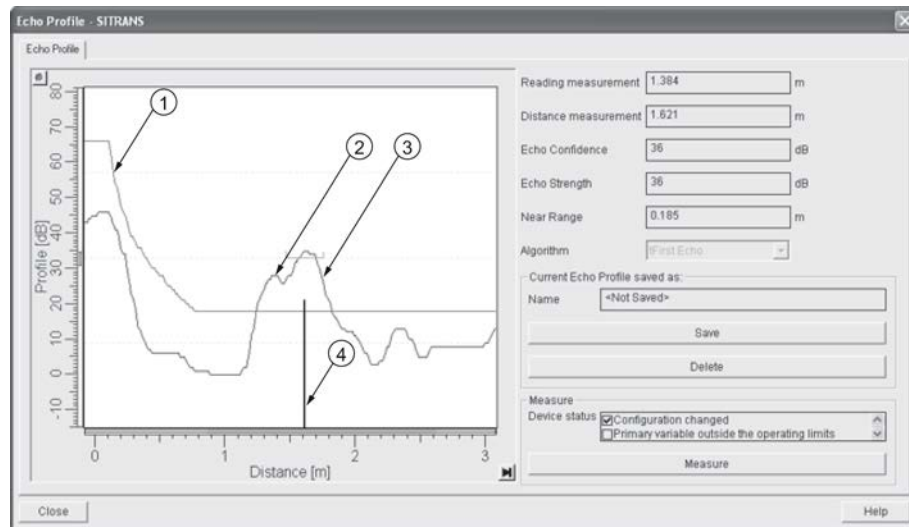

- ① default TVT
- ② material echo
- ③ vessel bottom echo selected
- ④ echo marker

Example: CLEF enabled

Vessel height: 1.5 m; CLEF range set to 0.5 m

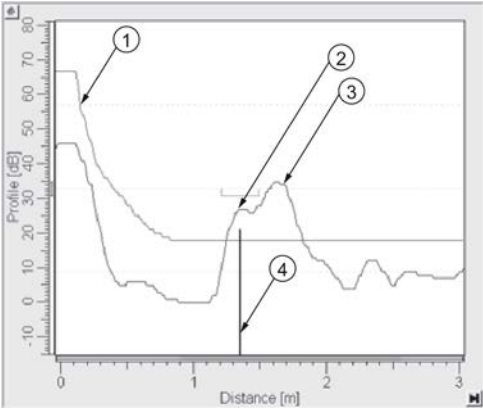

- ① default TVT
- ② material echo selected
- ③ vessel bottom echo
- ④ echo marker

A.2.3 CLEF Range

CLEF Range (2.5.7.4.) is referenced from Low Calibration Point (process empty level). When the **Hybrid** algorithm is selected in **Position Detect (2.5.7.2.)**, the CLEF algorithm will be applied up to the limit of CLEF Range. Above this limit the Center algorithm will be applied.

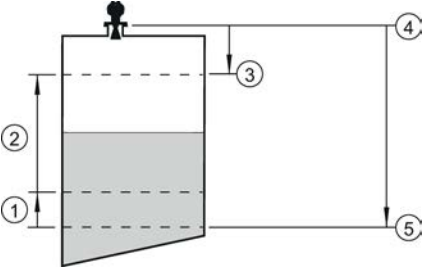

- ① CLEF Range
- ② (Center algorithm applied)
- ③ High Calibration Point (process full level)
- ④ Sensor reference point
- ⑤ Low Calibration Point (process empty level)

A.2.4 Measurement Response

Note

Units are defined in **Units (2.3.1.)** and are in meters by default.

Response Rate (2.3.8.1.) limits the maximum rate at which the display and output respond to changes in the measurement. There are three preset options: slow, medium, and fast.

Once the real process fill/empty rate (m/s by default) is established, a response rate can be selected that is slightly higher than the application rate. Response Rate automatically adjusts the filters that affect the output response rate.

Note

Changing Response Rate resets **Fill Rate per Minute (2.3.8.2.)**, **Empty Rate per Minute (2.3.8.3.)**, and **Shots (2.5.6.)**.

Response Rate (2.3.8.1)		Fill Rate (2.3.8.2)/Empty Rate (2.3.8.3)	
*	Slow	0.1 m/min (0.32 ft/min)	25
	Medium	1.0 m/min (3.28 ft.min)	10
	Fast	10.0 m/min (32.8 ft/min)	5

A.2.5 Echo Threshold

Confidence (2.5.9.1.) describes the quality of an echo. Higher values represent higher quality. **Echo Threshold (2.5.7.3.)** defines the minimum confidence value required for an echo to be accepted as valid and evaluated.

A.2.6 Echo Lock

If the echo selected by **Algorithm** is within the Echo Lock window, the window is centered about the echo, which is used to derive the measurement. In radar applications, two measurement verification options are used:

Lock Off

SITRANS LR250 responds immediately to a new selected echo (within the restrictions set by the Maximum Fill / Empty Rate), but measurement reliability is affected.

Material Agitator

A new measurement outside the Echo Lock Window must meet the sampling criteria before the window will move to include it.

The other available options, **Maximum Verification** and **Total Lock** are not recommended for radar.

A.2.7 Auto False Echo Suppression

Note

- For detailed instructions on using this feature via AMS see TVT (time varying threshold) (Page 100).
 - For detailed instructions on using this feature via the handheld programmer see **Auto False Echo Suppression (2.5.10.1.)**.
-

Auto False Echo Suppression is designed to learn a specific environment (for example, a particular vessel with known obstructions), and in conjunction with Auto False Echo Suppression Range to remove false echoes appearing in front of the material echo.

The material level should be below all known obstructions at the moment when Auto False Echo Suppression learns the echo profile. Ideally the vessel should be empty or almost empty, and if an agitator is present, it should be running.

The device learns the echo profile over the whole measurement range and the TVT is shaped around all echoes present at that moment.

Auto False Echo Suppression Range (2.5.10.2.)

Auto False Echo Suppression Range specifies the range within which the learned TVT is applied. Default TVT is applied over the remainder of the range.

The learned TVT screens out the false echoes caused by obstructions. The default TVT allows the material echo to rise above it.

Auto False Echo Suppression Range must be set to a distance shorter than the distance to the material level when the environment was learned, to avoid the material echo being screened out.

Example before Auto False Echo Suppression

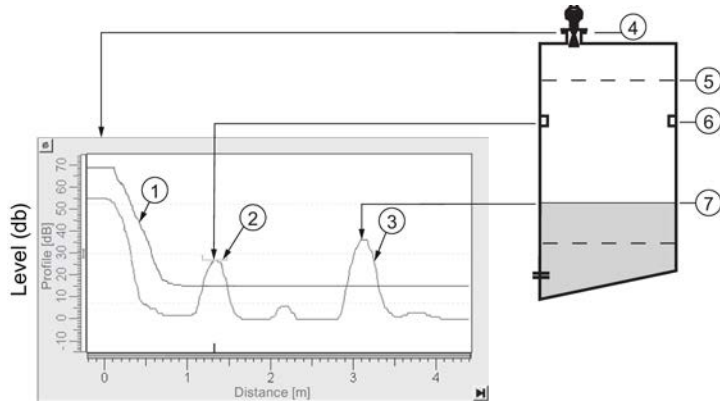

- | | | | |
|---|------------------------|---|----------------------------|
| ① | Default TVT | ⑤ | High calibration point = 0 |
| ② | False echo | ⑥ | Obstruction at 1.3. m |
| ③ | Material echo | ⑦ | Material level at 3.2 m |
| ④ | Sensor reference point | | |

Example after Auto False Echo Suppression

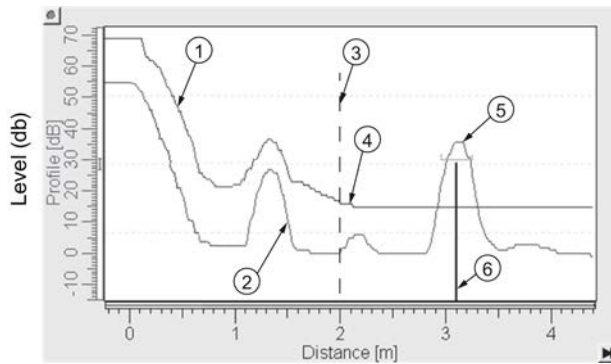

Auto False Echo
Suppression
Range set to 2 m

- | | | | |
|---|-----------------------------------|---|---------------|
| ① | Learned TVT | ④ | Default TVT |
| ② | False echo | ⑤ | Material echo |
| ③ | Auto False Echo Suppression Range | ⑥ | Echo marker |

A.2.8 Measurement Range

Near Range (2.5.1.)

Near Range programs SITRANS LR250 to ignore the zone in front of the antenna. The default blanking distance is 50 mm (1.97") from the end of the antenna.

Near Range allows you to increase the blanking value from its factory default. But **Auto False Echo Suppression (2.5.10.1.)** is generally recommended in preference to extending the blanking distance from factory values.

Far Range (2.5.2.)

Far Range can be used in applications where the base of the vessel is conical or parabolic. A reliable echo may be available below the vessel empty distance, due to an indirect reflection path.

Increasing Far Range to 30% or 40% can provide stable empty vessel readings.

A.2.9 Damping

Filter Time Constant (2.6.7.1) smooths out the response to a sudden change in level. This is an exponential filter and the engineering unit is always in seconds.

In 5 time constants the output rises exponentially: from 63.2% of the change in the first time constant, to almost 100% of the change by the end of the 5th time constant.

Damping example

time constant = 2 seconds
input (level) change = 2 m

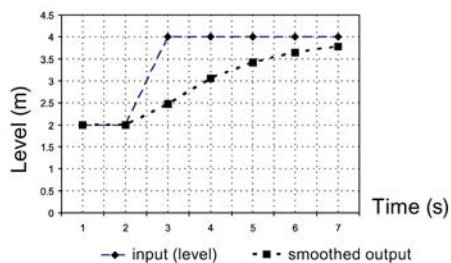

A.2.10 Loss of Echo (LOE)

A loss of echo (LOE) occurs when the calculated measurement is judged to be unreliable because the echo confidence value has dropped below the echo confidence threshold.

Confidence (2.5.9.1.) describes the quality of an echo. Higher values represent higher quality.

Echo Threshold (2.5.7.3.) defines the minimum confidence value required for an echo to be accepted as valid and evaluated.

If the LOE condition persists beyond the time limit set in **LOE Timer (2.3.6.)** the LCD displays the Service Required icon, and the text region displays the fault code **S: 0** and the text **LOE**.

If two faults are present at the same time, the fault code, error text, and error icon for each fault are displayed alternately. For example, Loss of Echo and faulty power supply:



Upon receiving a reliable echo, the loss of echo condition is aborted, the Service Required icon and error message are cleared, and the reading returns to the current level.

A.2.10.1 LOE Timer

Loss of Echo (LOE) Timer (2.3.6.) determines the length of time a Loss of Echo (LOE) condition will persist before the function block will show a status of BAD or UNCERTAIN. The default is 100 seconds.

A.3 Maximum Process Temperature Chart

 WARNING
Exceeded maximum internal and process temperatures Danger of device malfunction <ul style="list-style-type: none">• Internal temperature must not exceed +80 ° C (+176 °F).• Process temperature must not exceed limits specified by the antenna type.

Note

- The chart below is for guidance only.
- The chart does not represent every possible process connection arrangement. For example, it will NOT apply if you are mounting SITRANS LR250 directly on a metallic vessel surface.
- The chart does not take into consideration heating from direct sunlight exposure.

Maximum Process Temperatures versus allowable ambient

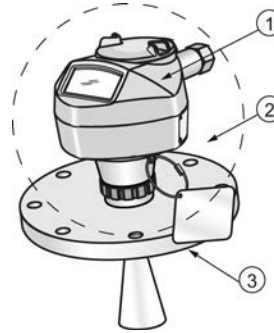
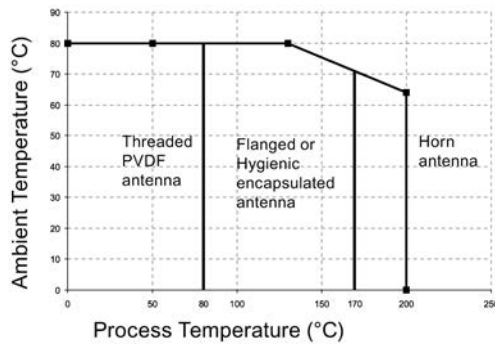

- ① Internal enclosure temperature
- ② Ambient temperature
- ③ Process temperature (at process connection)

Where the chart does not apply, please use your own judgement regarding the use of SITRANS LR250.

If the internal temperature exceeds the maximum allowable limit, a sun shield or a longer nozzle may be required.

See **Minimum Value (3.3.1.)** and **Maximum Value (3.3.2.)** to monitor the Internal Temperature.

A.4 Process Pressure/Temperature derating curves

 WARNING
Exceeded maximum permissible operating pressure Danger of injury or poisoning. The maximum permissible operating pressure depends on the device version. The device can be damaged if the operating pressure is exceeded. Hot, toxic and corrosive process media could be released. <ul style="list-style-type: none">• Make sure that the device is suitable for the maximum permissible operating pressure of your system.

 DANGER
Pressure applications Danger to personnel, system and environment will result from improper disassembly. <ul style="list-style-type: none">• Never attempt to loosen, remove, or disassemble process connection while vessel contents are under pressure.

 WARNING
Pressure applications Danger to personnel, system and environment can result from improper installation. <ul style="list-style-type: none">• Improper installation may result in loss of process pressure.

 WARNING
Unsuitable connecting parts Danger of injury or poisoning. In case of improper mounting hot, toxic and corrosive process media could be released at the connections. <ul style="list-style-type: none">• Ensure that connecting parts (such as flange gaskets and bolts) are suitable for connection and process media.

Note

Material compatibility

Siemens can provide you with support concerning selection of sensor components wetted by process media. However, you are responsible for the selection of components. Siemens accepts no liability for faults or failures resulting from incompatible materials.

A.4.1 Pressure Equipment Directive, PED, 97/23/EC

Siemens Level Transmitters with flanged, threaded, or sanitary clamp type process mounts have no pressure-bearing housing of their own and, therefore, do not come under the Pressure Equipment Directive as pressure or safety accessories (see EU Commission Guideline 1/8 and 1/20).

A.4.2 Horn antenna

1.5", 2" and 3" [NPT, G (BSPP), R (BSPT)] Threaded Versions

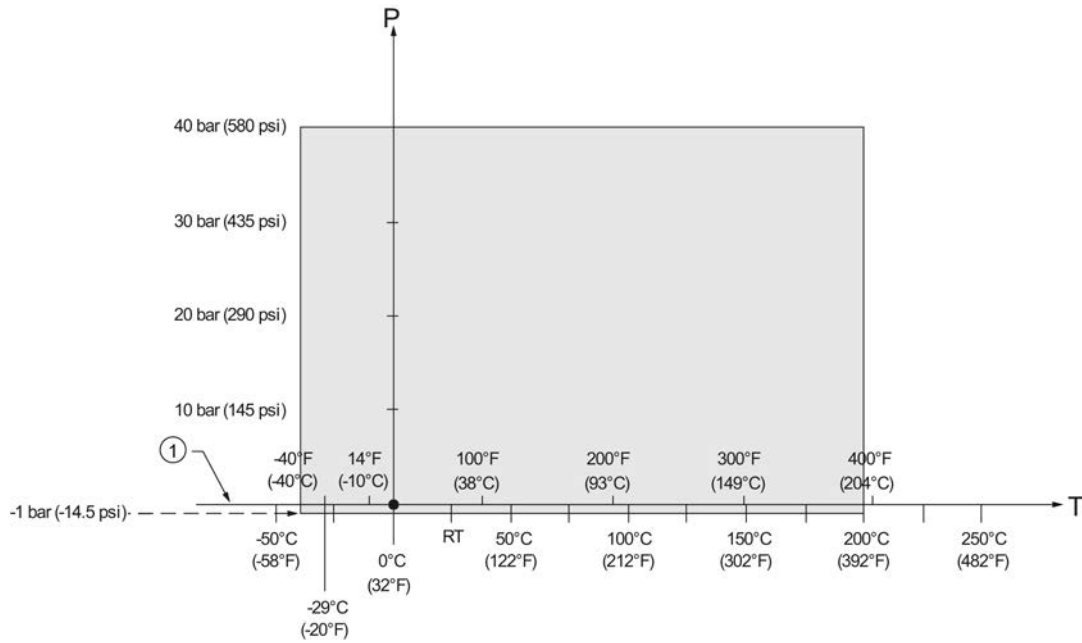

- ① Atmospheric
- P Allowable operating pressures
- T Allowable operating temperatures

A.4.3 Flanged horn antenna

JIS B 2220, 10K: 50A, 80A, and 100A

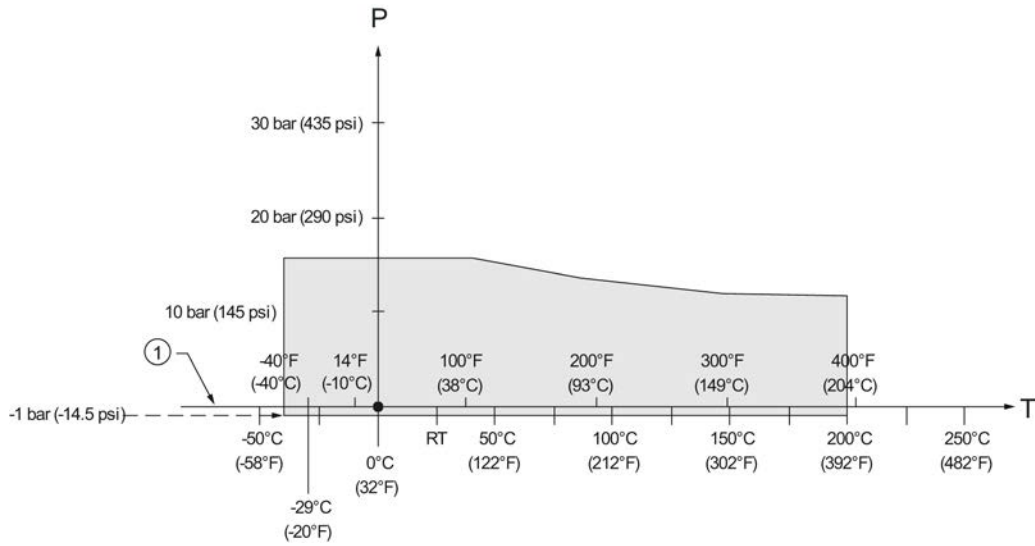

- ① Atmospheric
- P Allowable operating pressures
- T Allowable operating temperatures

EN1092-1, PN16: DN50, DN80, DN100, and DN150

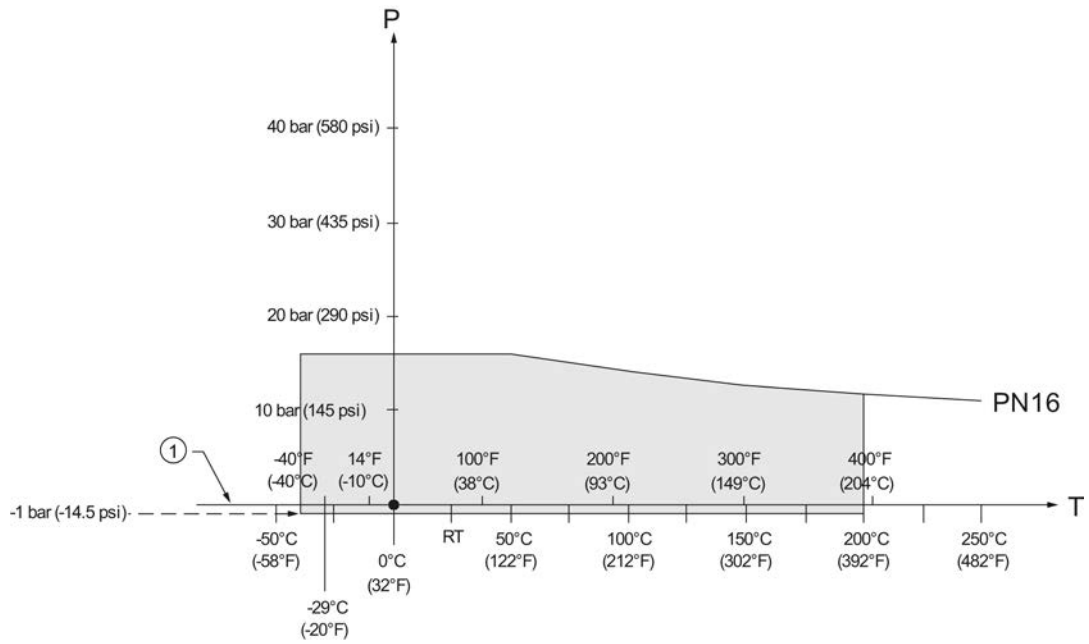

- ① Atmospheric
- P Allowable operating pressures
- T Allowable operating temperatures

EN1092-1, PN40: DN50, DN80, DN100, and DN150

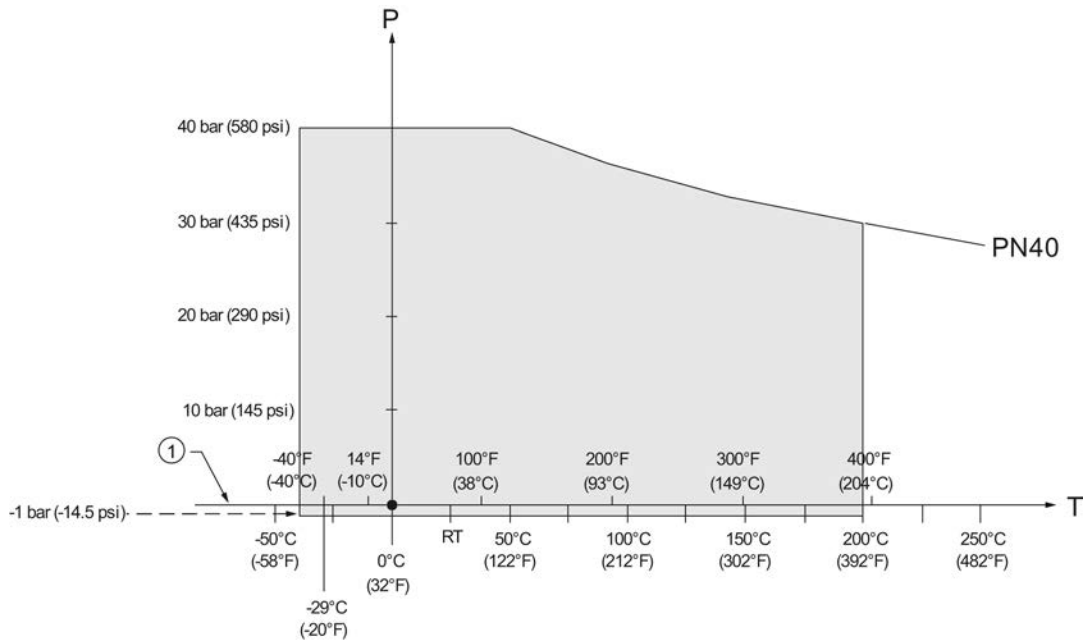

- ① Atmospheric
- P Allowable operating pressures
- T Allowable operating temperatures

ASME B16.5, Class 150: 2", 3", and 4" NPS

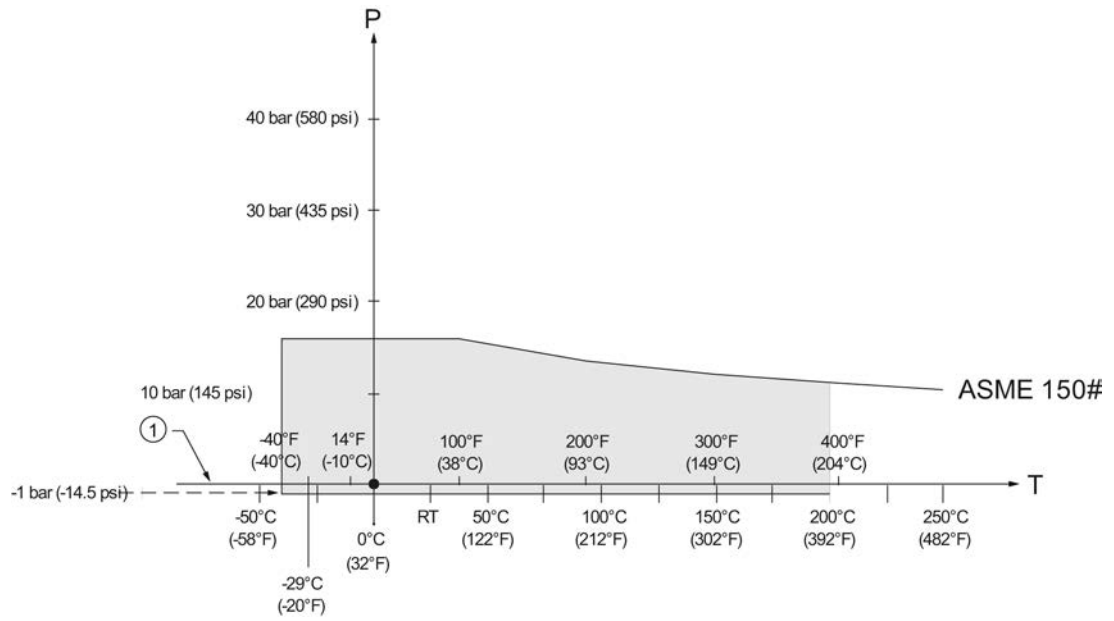

- ① Atmospheric
- P Allowable operating pressures
- T Allowable operating temperatures

ASME B16.5, Class 300: 2", 3", and 4" NPS

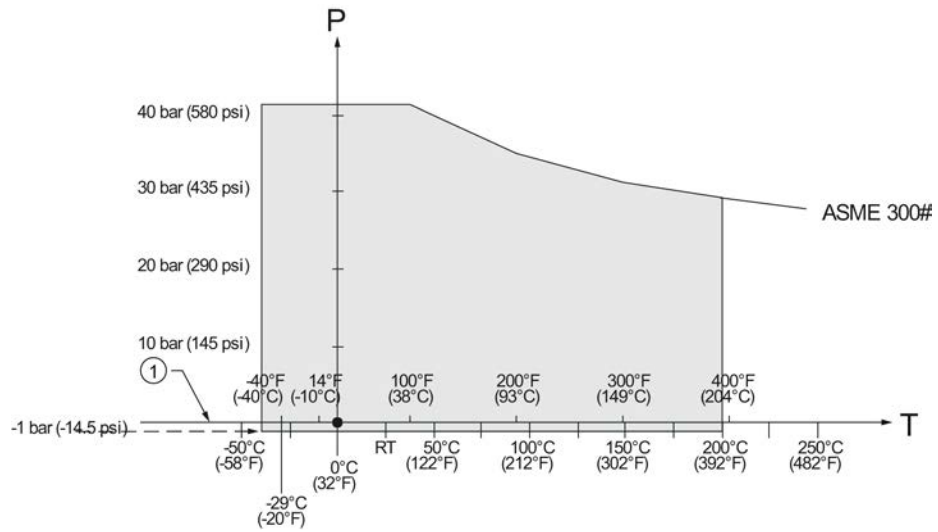

- ① Atmospheric
- P Allowable operating pressures
- T Allowable operating temperatures

A.4.4 Flanged encapsulated antenna

ASME B16.5, Class 150: 2", 3", 4", and 6" NPS

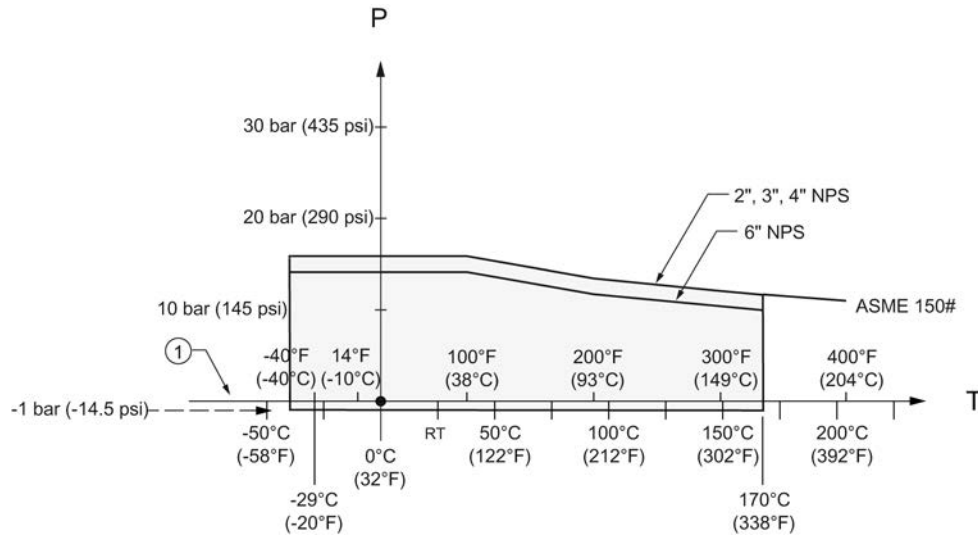

- ① Atmospheric
- P Allowable operating pressures
- T Allowable operating temperatures

JIS B 2220, 10K: 50A, 80A, 100A, and 150A

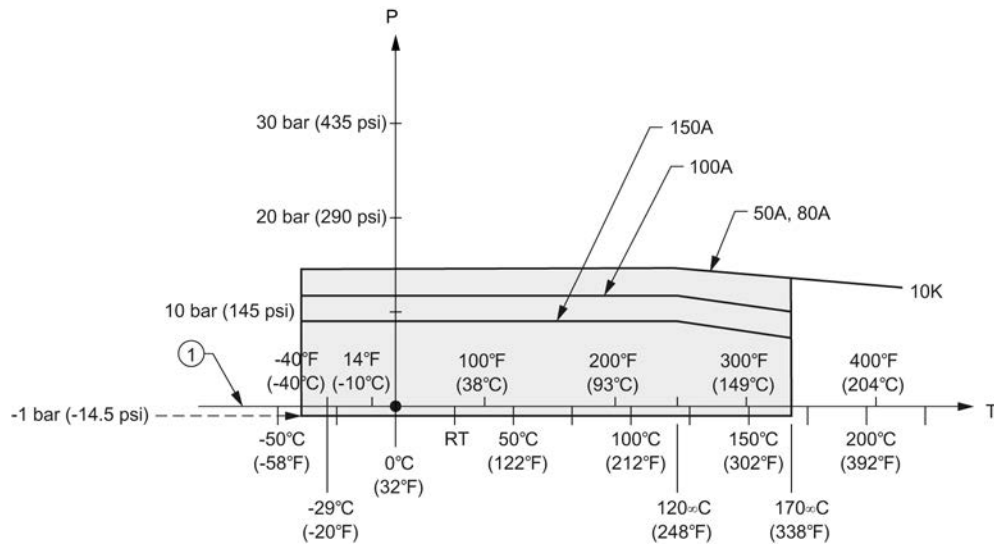

- ① Atmospheric
- P Allowable operating pressures
- T Allowable operating temperatures

EN1092-1, PN10/16: DN50, DN80, DN100, and DN150

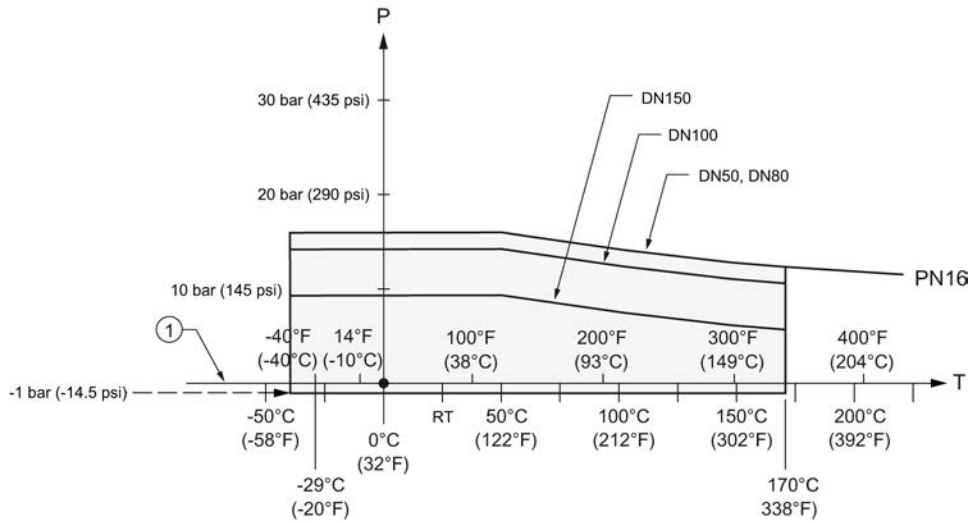

- ① Atmospheric
- P Allowable operating pressures
- T Allowable operating temperatures

A.4.5 PVDF antenna

ASME B1.20.1 2" NPT, EN ISO 228-1 2" G (BSPP), EN 10226-1 2" R (BSPT)

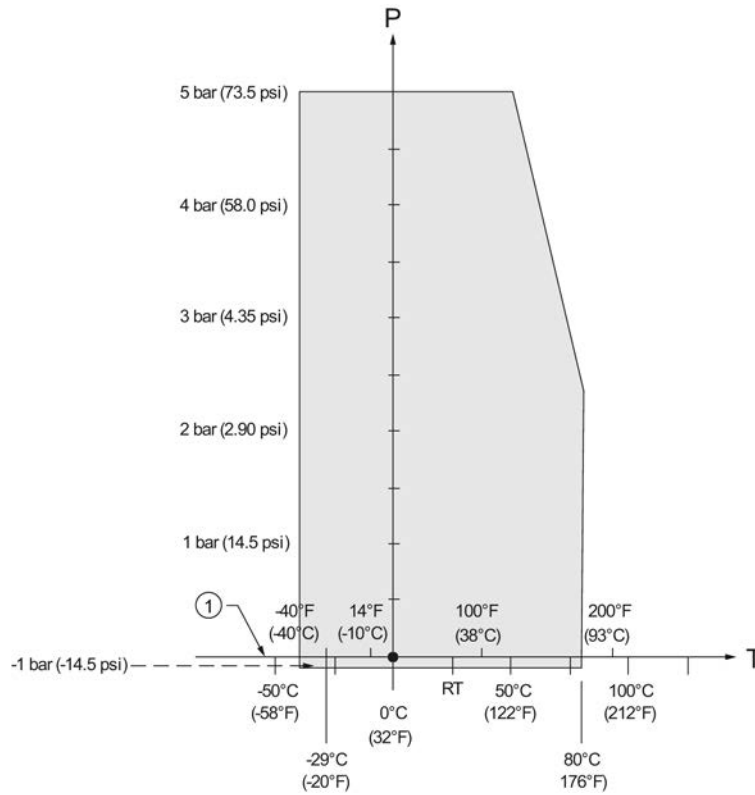

- ① Atmospheric
- P Allowable operating pressures
- T Allowable operating temperatures

A.4.6 Hygienic encapsulated antenna

DIN 11851 Sanitary/Hygienic nozzle/slotted nut: DN50, DN80, and DN100

DIN 11864-1 Aseptic/Hygienic nozzle/slotted nut: DN50, DN80, and DN100

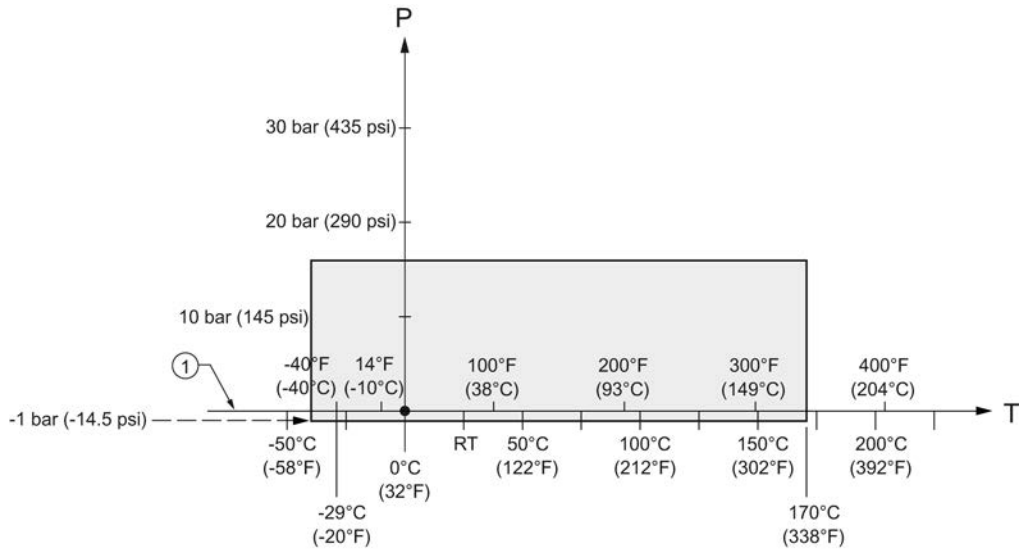

- ① Atmospheric
- P Allowable operating pressures
- T Allowable operating temperatures

DIN 11864-2 Aseptic/Hygienic flanged: DN50, DN80, and DN100

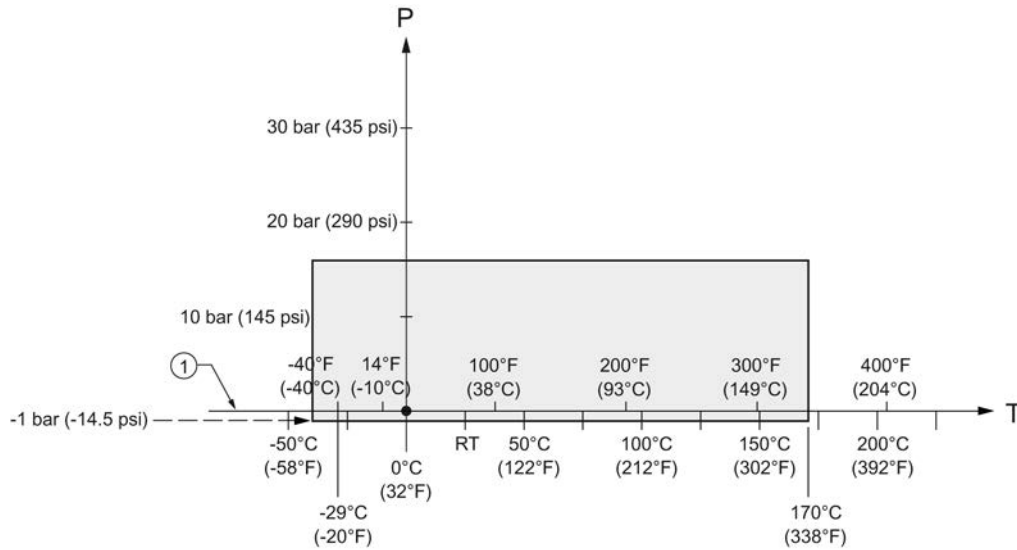

- ① Atmospheric
- P Allowable operating pressures
- T Allowable operating temperatures

Note

For pressure applications, all attachment hardware must be suitably rated.

DIN 11864-3 Aseptic/Hygienic clamp: DN50, DN80, and DN100

ISO 2852 Sanitary/Hygienic clamp: 2", 3", and 4"

Tuchenhagen Varivent face seal clamp: Type N (68 mm) and Type F (50 mm)

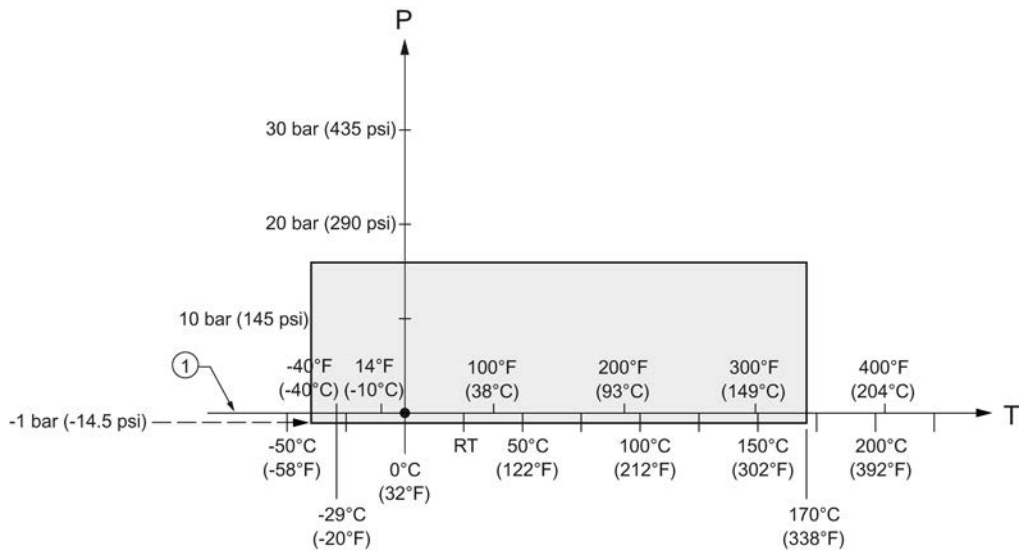

- ① Atmospheric
- P Allowable operating pressures
- T Allowable operating temperatures

Note

For pressure applications, all clamps must be rated accordingly.

Appendix B: Communications via Foundation Fieldbus

B

SITRANS LR250 (Foundation Fieldbus) is an FF (H1) device of Class 31PS, and 32L. It supports publish and subscribe functionality as well as Backup LAS functionality. The full range of SITRANS LR250 functions is available only over an FF network.

Foundation Fieldbus (FF) is an open industrial protocol. Full details about FF can be obtained from:

Foundation Fieldbus (<http://www.fieldbus.org>)

For details on the use of Foundation Fieldbus protocol with Siemens FF level instruments, see manual *Foundation Fieldbus for Level Instruments* (7ML19985MP01). The manual is available on the CD of Siemens manuals, included in the box with your Siemens level instrument, or for other Siemens level measurement manuals, go to:

Siemens level (<http://www.siemens.com/level>)

Look under **Level Measurement**.

B.1 Field Communicator 375 (F375)

This device supports Field Communicator 375 (FC375). The FC375 menu structure is very similar to the menu structure for AMS Device Manager [see AMS Menu Structure (Page 79).]

Appendix C: Certificates and support

C.1 Certificates

Certificates can be downloaded from our website at:

Product page (<http://www.siemens.com/LR250>).

C.2 Technical support

If you have any technical questions about the device described in these Operating Instructions and do not find the right answers, you can contact Customer Support:

- Via the Internet using the **Support Request**:
Support request (<http://www.siemens.com/automation/support-request>)
- Via Phone:
 - Europe: +49 (0)911 895 7222
 - America: +1 423 262 5710
 - Asia-Pacific: +86 10 6475 7575

Further information about our technical support is available on the Internet at
Technical support (<http://support.automation.siemens.com/WW/view/en/16604318>)

Service & Support on the Internet

In addition to our documentation, we offer a comprehensive knowledge base online on the Internet at:

Service & Support (<http://www.siemens.com/automation/service&support>)

There you will find:

- The latest product information, FAQs, downloads, tips and tricks.
- Our newsletter, providing you with the latest information about your products.
- Our bulletin board, where users and specialists share their knowledge worldwide.
- You can find your local contact partner for Industry Automation and Drives Technologies in our partner database.
- Information about field service, repairs, spare parts and lots more under "Services."

Additional Support

Please contact your local Siemens representative and offices if you have additional questions about the device

Find your contact partner at:

Local contact person (<http://www.siemens.com/automation/partner>)

List of abbreviations

Short form	Long form	Description	Units
3-A	3-A Sanitary Standards, Inc.		
AIFB	Analog Input Function Block		
CE / FM / CSA	Conformité Européene / Factory Mutual / Canadian Standards Association	safety approval	
C _i	Internal capacitance		F
D/A	Dialog to analog		
DCS	Distributed Control System	control room apparatus	
dK	dielectric constant		
EDD	Electronic Device Description		
EHEDG	European Hygienic Engineering Design Group		
FEA	Flanged encapsulated antenna		
FDA	Food and Drug Administration		
HEA	Hygienic encapsulated antenna		
I _i	Input current		mA
I _o	Output current		mA
IS	Intrinsically Safe	safety approval	
L _i	Internal inductance		mH
mH	milliHenry	10 ⁻³	H
μF	microFarad	10 ⁻⁶	F
μs	microsecond	10 ⁻⁶	s
PED	Pressure Equipment Directive	safety approval	
pF	pico Farads	10 ⁻¹²	F
ppm	parts per million		
PV	Primary Variable	measured value	
PVDF	Polyvinylidene fluoride		
SELV	Safety extra low voltage		
SV	Secondary Variable	equivalent value	
TB	Transducer Block		
TVT	Time Varying Threshold	sensitivity threshold	
TFM1600 PTFE	Modified PTFE	polytetrafluoroethylene with perfluoropropyl vinyl ether (PPVE) modifier	
U _i	Input voltage		V
U _o	Output voltage		V

LCD menu structure

14

Note

- In Navigation mode, **ARROW keys** (◀ ▶ ▲ ▼) navigate the menu in the direction of the arrow. See Parameter Reference (Page 143) for detailed information and instructions.
-

LEVEL METER

- 1. QUICK START WIZ
 - 1.1 QUICK START
 - MATERIAL
 - RESPONSE RATE
 - UNITS
 - OPERATION
 - LOW CALIB. PT.
 - HIGH CALIB. PT.
 - WIZARD COMPLETE
- 2. SETUP
 - 2.1 IDENTIFICATION
 - 2.1.1 TAG
 - 2.1.2 DESCRIPTOR
 - 2.1.3 MESSAGE
 - 2.2 DEVICE
 - 2.2.1 HARDWARE REV
 - 2.2.2 FIRMWARE REV
 - 2.2.3 LOADER REV
 - 2.3 SENSOR
 - 2.3.1 UNIT
 - 2.3.2 LEVEL UNIT
 - 2.3.3 PV UNITS
 - 2.3.4 TEMP UNITS
 - 2.3.5 MATERIAL
 - 2.3.6 LOE TIMER
 - 2.3.7 CALIBRATION
 - 2.3.7.1 LOW CALIB. PT.
 - 2.3.7.2 HIGH CALIB. PT.
 - 2.3.7.3 SENSOR OFFSET
 - 2.3.7.4 LOW LEVEL POINT
 - 2.3.7.5 HIGH LEVEL POINT
 - 2.3.7.6 LEVEL OFFSET
 - 2.3.8 RATE
 - 2.3.8.1 RESPONSE RATE
 - 2.3.8.2 FILL RATE/MIN
 - 2.3.8.3 EMPTY RATE/MIN
 - 2.4 LINEARIZATION
 - 2.4.1 VOLUME
 - 2.4.1.1 VESSEL SHAPE
 - 2.4.1.2 MAX VOLUME
 - 2.4.1.3 DIMENS. A
 - 2.4.1.4 DIMENS. L
 - 2.4.1.5 XY INDEX
 - 2.4.1.6 X VALUE
 - 2.4.1.7 Y VALUE
 - 2.5 SIGNAL PROC.
 - 2.5.1 NEAR RANGE
 - 2.5.2 FAR RANGE
 - 2.5.3 PROPAG. FACTOR
 - 2.5.4 MIN SENSOR VAL
 - 2.5.5 MAX SENSOR VAL
 - 2.5.6 SHOTS
 - 2.5.7 ECHO SELECT
 - 2.5.7.1 ALGORITHM
 - 2.5.7.2 POS. DETECT
 - 2.5.7.3 ECHO THRESHOLD
 - 2.5.7.4 CLEF RANGE

- 2. SETUP (cont'd)
 - 2.5.8 SAMPLING
 - 2.5.8.1 ECHO LOCK
 - 2.5.8.2 UP SAMP.
 - 2.5.8.3 DOWN SAMP.
 - 2.5.9 ECHO QUALITY
 - 2.5.9.1 CONFIDENCE
 - 2.5.9.2 ECHO STRENGTH
 - 2.5.10 TVT SETUP
 - 2.5.10.1 AUTO ECHO SUPP
 - 2.5.10.2 AUTO SUPP RANGE
 - 2.5.10.3 HOVER LEVEL
 - 2.5.10.4 SHAPER MODE
 - 2.5.11 TVT SHAPER
 - 2.5.11.1 BRKPT. 1-9
 - 2.5.11.2 BRKPT. 10-18
 - 2.5.11.3 BRKPT. 19-27
 - 2.5.11.4 BRKPT. 28-36
 - 2.5.11.5 BRKPT. 37-40
 - 2.6 AIFB 1
 - 2.6.1 STATIC REV. NO.
 - 2.6.2 MODE
 - 2.6.3 CHANNEL
 - 2.6.4 INPUT SCALING
 - 2.6.4.1 LOWER VALUE
 - 2.6.4.2 UPPER VALUE
 - 2.6.4.3 UNIT
 - 2.6.4.4 DECIMAL POINT
 - 2.6.5 OUTPUT SCALING
 - 2.6.5.1 LOWER VALUE
 - 2.6.5.2 UPPER VALUE
 - 2.6.5.3 UNIT
 - 2.6.5.4 DECIMAL POINT
 - 2.6.6 ALARMS & WARNI..
 - 2.6.6.1 HI LIMIT ALARM
 - 2.6.6.2 HI LIMIT WARN
 - 2.6.6.3 LO LIMIT WARN
 - 2.6.6.4 LO LIMIT ALARM
 - 2.6.6.5 LIMIT HYSTERESI..
 - 2.6.6 DISPLAY
 - 2.6.7.1 FILTER TIME CONS..
 - 2.7 AIFB 2
 - 2.7.1 STATIC REV. NO.
 - 2.7.2 MODE
 - 2.7.3 CHANNEL
 - 2.7.4 INPUT SCALING
 - 2.7.4.1 LOWER VALUE
 - 2.7.4.2 UPPER VALUE
 - 2.7.4.3 UNIT
 - 2.7.4.4 DECIMAL POINT
 - 2.7.5 OUTPUT SCALING
 - 2.7.5.1 LOWER VALUE
 - 2.7.5.2 UPPER VALUE
 - 2.7.5.3 UNIT
 - 2.7.5.4 DECIMAL POINT
 - 2.7.6 ALARMS & WARNI..
 - 2.7.6.1 HI LIMIT ALARM
 - 2.7.6.2 HI LIMIT WARN
 - 2.7.6.3 LO LIMIT WARN
 - 2.7.6.4 LO LIMIT ALARM
 - 2.7.6.5 LIMIT HYSTERESI..
 - 2.7.7 DISPLAY
 - 2.7.7.1 FILTER TIME CONS..
 - 2.8 DISPLAY
 - 2.8.1 MAIN OUTPUT
 - 2.8.2 O/P NO LINEAR
 - 2.8.3 O/P NO OFFSETS

- 3. **DIAGNOSTICS**
 - 3.1 ECHO PROFILE
 - 3.2 FAULT RESET
 - 3.2 ELECT. TEMP.
 - 3.3.1 MIN. VALUE
 - 3.3.2 MAX. VALUE
 - 3.4 PEAK VALUES
 - 3.4.1 MIN MEAS. VALUE
 - 3.4.2 MAX MEAS. VALUE
- 4. **SERVICE**
 - 4.1 MASTER RESET
 - 4.2 REMAIN. DEV. LIFE
 - 4.2.1 LIFETIME EXPECT..
 - 4.2.2 TIME IN OPER..
 - 4.2.3 REMAIN. LIFETIM..
 - 4.2.4 REMINDER ACTIV..
 - 4.2.5 REMIND. 1 (REQ.)
 - 4.2.6 REMIND. 2 (DEM.)
 - 4.2.7 MAINT STAT
 - 4.2.8 ACK STATUS
 - 4.2.9 ACK
 - 4.3 REMAIN. SENS. LIFE
 - 4.3.1 LIFETIME EXPECT..
 - 4.3.2 TIME IN OPER..
 - 4.3.3 REMAIN. LIFETIM..
 - 4.3.4 REMINDER ACTIV..
 - 4.3.5 REMIND. 1 (REQ.)
 - 4.3.6 REMIND. 2 (DEM.)
 - 4.3.7 MAINT STAT
 - 4.3.8 ACK STATUS
 - 4.3.9 ACK
 - 4.4 SERVICE SCHED.
 - 4.4.1 SERV. INTERVAL
 - 4.4.2 TIME LAST SERV.
 - 4.4.3 TIME NEXT SERVI..
 - 4.4.4 REMINDER ACTIV..
 - 4.4.5 REMIND. 1 (REQ.)
 - 4.4.6 REMIND. 2 (DEM.)
 - 4.4.7 MAINT STAT
 - 4.4.8 ACK STATUS
 - 4.4.9 ACK
 - 4.5 CALIB SCHED.
 - 4.5.1 CALIB. INTERNAL
 - 4.5.2 TIME LAST CALIB.
 - 4.5.3 TIME NEXT CALIB.
 - 4.5.4 REMINDER ACTIV..
 - 4.5.5 REMIND. 1 (REQ.)
 - 4.5.6 REMIND. 2 (DEM.)
 - 4.5.7 MAINT STAT
 - 4.5.8 ACK STATUS
 - 4.5.9 ACK
 - 4.6 MANUF. DATE
 - 4.7 POWERED HOURS
 - 4.8 POWERON RESETS
 - 4.9 LCD FAST MODE
 - 4.10 LCD CONTRAST
 - 4.11 SECONDARY VALUE
 - 4.12 SIMULATE ENABLE
- 5. **COMMUNICATION**
 - 5.1 DEVICE ADDRESS
- 6. **SECURITY**
 - 6.1 REMOTE ACCESS
 - 6.1.1 ACCESS CONTROL
 - 6.2 LOCAL ACCESS
 - 6.2.1 WRITE PROTECT
 - 6.2.2 PIN TO UNLOCK
- 7. **LANGUAGE**

Glossary

accuracy

degree of conformity of a measure to a standard or a true value.

algorithm

a prescribed set of well-defined rules or processes for the solution of a problem in a finite number of steps.

ambient temperature

the temperature of the surrounding air that comes in contact with the enclosure of the device.

antenna

an aerial which sends out and receives a signal in a specific direction. There are four basic types of antenna in radar level measurement, horn, parabolic, rod, and waveguide.

Auto False-Echo Suppression

a technique used to adjust the level of a TVT to avoid the reading of false echoes. (See TVT.)

Auto-False Echo Suppression Range

defines the endpoint of the learned TVT distance. (See TVT.) This is used in conjunction with auto false echo suppression.

beam angle

the angle diametrically subtended by the one-half power limits (-3 dB) of the microwave beam.

blanking

a blind zone extending away from the reference point plus any additional shield length. The device is programmed to ignore this zone.

capacitance

the property of a system of conductors and dielectrics that permits the storage of electricity when potential differences exist between the conductors. Its value is expressed as the ratio of a quantity of electricity to a potential difference, and the unit is a Farad.

confidence

see Echo Confidence.

damping

term applied to the performance of a device to denote the manner in which the measurement settles to its steady indication after a change in the value of the level.

dB (decibel)

a unit used to measure the amplitude of signals.

derating

to decrease a rating suitable for normal conditions according to guidelines specified for different conditions.

dielectric

a nonconductor of direct electric current. Many conductive liquids/electrolytes exhibit dielectric properties; the relative dielectric constant of water is 80.

dielectric constant (dK)

the ability of a dielectric to store electrical potential energy under the influence of an electric field. Also known as Relative Permittivity. An increase in the dielectric constant is directly proportional to an increase in signal amplitude. The value is usually given relative to a vacuum /dry air: the dielectric constant of air is 1. Many conductive liquids/electrolytes exhibit dielectric properties; the relative dielectric constant of water is 80.

echo

a signal that has been reflected with sufficient magnitude and delay to be perceived in some manner as a signal distinct from that directly transmitted. Echoes are frequently measured in decibels relative to the directly transmitted signal.

Echo Confidence

describes the quality of an echo. Higher values represent higher quality. Echo Threshold defines the minimum value required for an echo to be accepted as valid and evaluated.

Echo Lock Window

a window centered on an echo in order to locate and display the echo's position and true reading. Echoes outside the window are not immediately processed.

Echo Marker

a marker that points to the processed echo.

Echo Processing

the process by which the radar unit determines echoes.

Echo Profile

a graphical display of a processed echo.

Echo Strength

describes the strength of the selected echo in dB referred to 1 μ V rms.

false echo

any echo which is not the echo from the desired target. Generally, false echoes are created by vessel obstructions.

frequency

the number of periods occurring per unit time. Frequency may be stated in cycles per second.

hertz (Hz):

unit of frequency, one cycle per second. 1 Gigahertz (GHz) is equal to 10^9 Hz.

horn antenna

a conical, horn-shaped antenna which focuses microwave signals. The larger the horn diameter, the more focused the radar beam.

inductance

the property of an electric circuit by virtue of which a varying current induces an electromotive force in that circuit or in a neighboring circuit. The unit is a Henry.

multiple echoes

secondary echoes that appear as double, triple, or quadruple echoes in the distance from the target echo.

Near Blanking

see Blanking.

nozzle

a length of pipe mounted onto a vessel that supports the flange.

parameters

in programming, variables that are given constant values for specific purposes or processes.

polarization

the property of a radiated electromagnetic wave describing the time-varying direction and amplitude of the electric field vector.

propagation factor (pf)

where the maximum velocity is 1.0, pf is a value that represents a reduction in propagation velocity as a result of the wave travelling through a pipe or medium.

pulse radar

a radar type that directly measures distance using short microwave pulses. Distance is determined by the return transit time.

radar

radar is an acronym for RAdio Detection And Ranging. A device that radiates electromagnetic waves and utilizes the reflection of such waves from distant objects to determine their existence or position.

range

distance between a transmitter and a target.

range extension

the distance below the zero percent or empty point in a vessel.

relative humidity

the ratio of the actual amount of moisture in the atmosphere to the maximum amount of moisture the atmosphere could hold (which varies depending on the air temperature).

repeatability

the closeness of agreement among repeated measurements of the same variable under the same conditions.

shot

one transmit pulse or measurement.

stilling-well

see stillpipe.

stillpipe

a pipe that is mounted inside a vessel parallel to the vessel wall, and is open to the vessel at the bottom.

TVT (Time Varying Threshold)

a time-varying curve that determines the threshold level above which echoes are determined to be valid.

Index

A

- Abbreviations and identifications list, 295
- access control
 - local access, 189
 - remote access, 188
- activating LR250, 56
- agitator blade detection
 - avoiding, 160
- AMS Device Manager
 - features, 81
- antenna
 - replacement, 199
- antenna types
 - flanged encapsulated antenna, 231, 233
 - flanged horn antenna, 227
 - flanged horn antenna with extension, 229
 - threaded horn, 221
 - threaded PVDF antenna, 252
- Auto False Echo Suppression
 - explanation, 271
 - setup, 162

B

- beam angle
 - flanged encapsulated antenna, 231, 233
 - flanged horn, 227, 229
 - threaded horn, 223
 - threaded PVDF antenna, 252
- blanking (see Near Range), 273
- bolting instructions, 38
- bypass pipe
 - see stillpipe, 32

C

- cables
 - requirements, 42
- Calibration Interval, 183
- channel
 - transducer block outputs, 168

- cleaning
 - instructions, 197
- CLEF (Constrained Leading Edge Fit)
 - explanation, 268
- CLEF range
 - setup, 159
- conduits
 - requirements, 42
- configuration
 - new device via AMS, 85
 - Quick Start via LUI, 65
- Correct usage, (see Improper device modifications)

D

- damping
 - Filter Time Constant setup, 171
- Damping
 - explanation, 273
- Device Address, 187
- device nameplate
 - FM/CSA Class 1 Div. 2, 51
 - Intrinsically Safe (ATEX/IECEX), 48
 - Intrinsically Safe (FM/CSA), 48
- Device Reset
 - see Master Reset, 175
- Device Status
 - icons, 204
- Diagnostics
 - maintenance settings, 172
- dimensions
 - flanged encapsulated antenna, 231, 233
 - flanged horn, 227, 229
 - flat face flange, 259
 - raised face flange, 253, 256
 - threaded horn with extension, 223
 - threaded PVDF antenna, 252

E

- echo confidence
 - parameter setup, 161

- echo processing
 - Process Intelligence, 266
- Echo Profile
 - view via LUI, 70
- echo selection
 - Algorithm, 267
 - CLEF (Constrained Leading Edge Fit), 268
 - Position algorithm, 267
 - time varying threshold (TVT), 266
- edit mode
 - handheld programmer, 61
 - key functions, 64
- Empty rate
 - setup, 150
- enable/disable remote operation, 188
- enclosure
 - opening, 43

F

- factory defaults
 - Master Reset, 175
- false echo
 - see Auto False Echo Suppression, 271
- Far Range
 - explanation, 273
 - setup, 156
- fault codes
 - general fault codes, 205
- Fill Rate
 - setup, 149
- Filter Time Constant
 - explanation, 273
- flange
 - bolting instructions, 38
- flange markings
 - flat face, 259
 - raised face, 254, 257
- flange sizes
 - flat face, 259
 - raised face, 253, 256
- flanged encapsulated antenna
 - dimensions, 233
- flanged horn
 - dimensions, 227, 229

H

- handheld programmer
 - edit mode, 63
 - navigation, 62
 - programming, 60
- hazardous area installations
 - instructions, 52
 - wiring requirements, 46
- hysteresis
 - setup, 171

I

- Identifications and abbreviations
 - list, 295
- Improper device modifications, 17
- installation
 - hazardous area requirements, 46
 - requirements, 34
 - warnings and notes, 34
- internal temperature
 - monitoring, 274

K

- key functions
 - edit mode, 64
 - navigation mode, 62

L

- Language, 190
- LCD display
 - contrast adjustment, 186
 - echo profile viewing, 70
 - fast mode, 186
 - measurement mode, 57
- lens
 - replacement, 199
- lid-lock set screw, 43
- Limit Hysteresis
 - setup, 171
- Lithium batteries
 - Safety, 55
- Local User Interface (LUI), 57

LOE Timer
 explanation, 274
 setup, 147
 loop voltage vs. loop resistance
 power supply requirements, 48
 loss of echo (LOE)
 explanation, 274
 Loss of Echo (LOE)
 explanation, 274
 LUI (Local User Interface)
 contrast adjustment, 57

M

maintenance
 repairs, 197
 replacing antenna, 199
 replacing lens, 199
 Maintenance, 198
 maintenance settings
 Calibration Interval, 183
 see Diagnostics, 172
 see Remaining Sensor Lifetime, 179
 Service Interval, 181
 Master Reset
 factory defaults, 175
 measurement range
 blanking via Near Range, 273
 extension via Far Range, 273
 Measurement Response
 explanation, 270
 mounting
 bypass requirements, 32
 handheld programmer access, 30
 housing construction, 24, 31
 nozzle design, 27
 nozzle location, 28
 on vessel with obstructions, 31
 sunshield recommended, 31

N

nameplate
 Intrinsically Safe (ATEX/IECEX), 48
 Intrinsically Safe (FM/CSA), 48
 Near Range
 explanation, 273
 setup, 155

O

operating principles
 cleaning, 265
 Output limits
 setup, 170
 Output Scale
 setup, 169
 overview, 19

P

password protection
 via AMS, 129
 PED (Pressure Equipment Directive), 23, 277
 performance
 specifications, 213
 pipe sizes
 flange mounting, 253, 256
 polarization reference point, 31
 power source
 requirements, 42
 power supply requirements
 loop voltage vs. loop resistance, 48
 pressure applications, 23
 Pressure Equipment Directive, 23, 277
 Process Intelligence, 266
 process temperature
 maximum, 274
 programmer
 handheld, 59
 programming
 via the handheld programmer, 60
 propagation factor
 values, 156

Q

Qualified personnel, 18
 Quick Start Wizard
 via LUI, 65

R

raised face flange markings, 253, 255
 reading erratic
 troubleshooting, 211

reading incorrect
 troubleshooting, 211
reading response slow, 211
Remote Lockout, 188
repair
 cautions, 199
 excluded liability, 199
reset
 see Master Reset, 175
Response Rate
 explanation, 270
 setup, 149

S

safety notes, 15
Scope of delivery, 13
security
 local access unlock value, 189
 password protection via AMS, 129
sensor reference point
 flanged encapsulated antenna, 231, 233
 flanged horn, 227, 229
 flat faced flange, 259
 raised face flange, 253, 255
 threaded horn, 223
 threaded PVDF horn, 252
sidepipe
 see bypass pipe, 32
SITRANS LR250
 operating principles, 265
startup
 transition screen, 56
stillpipe
 mounting requirements, 32
Support
 contact information, 293

T

technical data, 213
 ambient temperature, 218
 antenna, 216
 enclosure, 216
 environmental, 218
 performance, 213
 power, 213

 pressure, 218
 process connections, 215
 process temperature, 218
 weight, 216
technical support
 contact information, 293
threaded connection markings, 252
threaded horn antenna
 dimensions, 223
threaded PVDF antenna
 dimensions, 252
transducer block outputs
 channel, 168
troubleshooting
 communication, 203
 operation, 210
TVT (time varying threshold)
 explanation, 266

V

vessel shape
 selection, 151

W

wiring
 cables, 42
 hazardous areas, 46
Write Protection, 189