

Exhibit A..... Technical Report, Diagram

Applicant Name And Address

Their full name and mailing address is given below:

Name: Dexin Corporation

***Address: 8F-8, No. 502, Yuan Shan Rd., Chung Ho City, Taipei Hsien,
Taiwan, R.O.C.***

Model No.: RFKB0102

Brand Name: ----

Exhibit C.....Measurement Report

FCC Part 15 EMI TEST REPORT

of

E.U.T. : RF Wireless Keyboard

MODEL : RFKB0102

FCC ID. : NIYRFKB0102

for

APPLICANT : Dexin Corporation

ADDRESS : 8F-8, No. 502, Yuan Shan Rd., Chung Ho City,
Taipei Hsien, Taiwan, R.O.C.

Test Performed by

ELECTRONICS TESTING CENTER, TAIWAN
NO. 8 LANE 29, WENMIMG ROAD,
LOSHAN TSUN, KWEISHAN HSIANG,
TAOYUAN, TAIWAN, R.O.C.

Tel:(03)3280026-32

Fax:(03)3280034

Report Number : ET88R-08-051-01

TEST REPORT CERTIFICATION

Applicant : Dexin Corporation
8F-8, No. 502, Yuan Shan Rd., Chung Ho City, Taipei Hsien, Taiwan,
R.O.C.

Manufacturer : Dexin Corporation
8F-8, No. 502, Yuan Shan Rd., Chung Ho City, Taipei Hsien, Taiwan,
R.O.C.

Description of EUT :

- a) Type of EUT : RF Wireless Keyboard
- b) Trade Name : ----
- c) Model No. : RFKB0102
- d) Power Supply : DC 3V

Regulation Applied : FCC Rules and Regulations Part 15 Subpart C(1996)

I HEREBY CERTIFY THAT: The data shown in this report were made in accordance with the procedures given in ANSI C63.4, and the energy emitted by the device was founded to be within the limits applicable. I assume full responsibility for accuracy and completeness of these data.

- Note: 1. The result of the testing report relate only to the item tested.
2. The testing report shall not be reproduced expect in full, without the written approval of ETC.

Issued Date : SEP. 06, 1999

Test Engineer : Jeff Chuang
(Jeff Chuang)

Approve & Authorized Signer : Will Yauo
Will Yauo, Supervisor
EMI Test Site of ELECTRONICS
TESTING CENTER, TAIWAN

Table of Contents	Page
1 GENERAL INFORMATION	1
1.1 Product Description.....	1
1.2 Characteristics of Device	1
1.3 Test Methodology.....	1
1.4 Test Facility.....	1
2 PROVISIONS APPLICABLE	2
2.1 Definition	2
2.2 Requirement for Compliance	3
2.3 Restricted Bands of Operation	5
2.4 Labeling Requirement	5
2.5 User Information	6
3 SYSTEM TEST CONFIGURATION	7
3.1 Justification	7
3.2 Devices for Tested System	7
4 RADIATED EMISSION MEASUREMENT	8
4.1 Applicable Standard	8
4.2 Measurement Procedure	8
4.3 Measuring Instrument.....	10
4.4 Radiated Emission Data	11
4.5 Field Strength Calculation.....	11
4.6 Photos of Radiation Measuring Setup.....	12
5. CONDUCTED EMISSION MEASUREMENT	13
5.1 Standard Applicable	13
6 ANTENNA REQUIREMENT	14
6.1 Standard Applicable	14
6.2 Antenna Construction.....	14
7 BAND EDGES MEASUREMENT	15
7.1 Standard Applicable	15
7.2 Measurement Procedure	15
7.3 Measurement Equipment.....	15
7.4 Measurement Data.....	15

1 GENERAL INFORMATION

1.1 Product Description

- a) Type of EUT : RF Wireless Keyboard
- b) Trade Name : ----
- c) Model No. : RFKB0102
- d) Power Supply : DC 3V

1.2 Characteristics of Device

Once you connect the receiver to your computer and install the batteries to the keyboard, you can start to use the RF Wireless Keyboard. Since the keyboard is using RF wireless technology, it doesn't matter where you put the receiver. Even it is put behind the computer. When using the keyboard to type, it's not necessary as well to aim at the receiver. The maximum effective distance between the keyboard and the receiver is 30 feet (10 meters), depending on the situation of surrounding interference. Modulation type : AM.

1.3 Test Methodology

For RF Wireless Keyboard, both conducted and radiated emissions were performed according to the procedures illustrated in ANSI C63.4(1992). Other required measurements were illustrated in separate sections of this test report for details.

1.4 Test Facility

The open area test site and conducted measurement facility used to collect the radiated data is located on the roof top of Building at No.34, Lin 5, Ding Fu Tsun, Linkou Hsiang, Taipei Hsien, Taiwan, R.O.C.

This site has been fully described in a report submitted to your office, and accepted in a letter dated Feb. 10 , 1997.

2 PROVISIONS APPLICABLE

2.1 Definition

Unintentional radiator:

A device that intentionally generates and radio frequency energy for use within the device, or that sends radio frequency signals by conduction to associated equipment via connecting wiring, but which is not intended to emit RF energy by radiation or induction.

Class A Digital Device:

A digital device which is marketed for use in commercial or business environment; exclusive of a device which is market for use by the general public, or which is intended to be used in the home.

Class B Digital Device :

A digital device which is marketed for use in a residential environment notwithstanding use in a commercial, business of industrial environment. Example of such devices that are marketed for the general public.

Note : A manufacturer may also qualify a device intended to be marketed in a commercial, business, or industrial environment as a Class B digital device, and in fact is encouraged to do so, provided the device complies with the technical specifications for a Class B Digital Device. In the event that a particular type of device has been found to repeatedly cause harmful interference to radio communications, the Commission may classify such a digital device as a Class B Digital Device, Regardless of its intended use.

Intentional radiator:

A device that intentionally generates and emits radio frequency energy by radiation or induction.

2.2 Requirement for Compliance

(1) Conducted Emission Requirement

For unintentional device, according to § 15.107(a) Line Conducted Emission Limits is as following:

Frequency MHz	Emissions μV	Emissions dB μV
0.45 - 30.0	250	48.0

For intentional device, according to § 15.207(a) Line Conducted Emission Limits is same as above table.

(2) Radiated Emission Requirement

For unintentional device, according to § 15.109(a), except for Class A digital devices, the field strength of radiated emissions from unintentional radiators at a distance of 3 meters shall not exceed the following values:

Frequency MHz	Distance Meters	Radiated dB $\mu V/m$	Radiated $\mu V/m$
30 - 88	3	40.0	100
88 - 216	3	43.5	150
216 - 960	3	46.0	200
above 960	3	54.0	500

For intentional device, according to § 15.209(a), the general requirement of field strength of radiated emissions from intentional radiators at a distance of 3 meters shall not exceed the above table.

2.3 Restricted Bands of Operation

Only spurious emissions are permitted in any of the frequency bands listed below :

MHz	MHz	MHz	GHz
0.090 - 0.110	16.42-16.423	399.9-410	4.5-5.25
0.495 - 0.505 **	16.69475 - 16.69525	608-614	5.35-5.46
2.1735 - 2.1905	16.80425 - 16.80475	960-1240	7.25-7.75
4.125-4.128	25.5-25.67	1300-1427	8.025-8.5
4.17725-4.17775	37.5-38.25	1435-1626.5	9.0-9.2
4.20725-4.20775	73-74.6	1645.5-1646.5	9.3-9.5
6.215-6.218	74.8-75.2	1660-1710	10.6-12.7
6.26775-6.26825	108-121.94	1718.8-1722.2	13.25-13.4
6.31175-6.31225	123-138	2200-2300	14.47-14.5
8.291-8.294	149.9-150.05	2310-2390	15.35-16.2
8.362-8.366	156.52475 - 156.52525	2483.5-2500	17.7-21.4
8.37625-8.38675	156.7-156.9	2655-2900	22.01-23.12
8.41425-8.41475	162.0125-167.17	3260-3267	23.6-24.0
12.29-12.293	167.72-173.2	3332-3339	31.2-31.8
12.51975-12.52025	240-285	3345.8-3358	36.43-36.5
12.57675-12.57725	322-335.4	3360-4400	Above 38.6
13.36-13.41			

** : Until February 1, 1999, this restricted band shall be 0.490-0.510 MHz

2.4 Labeling Requirement

The device shall bear the following statement in a conspicuous location on the device :

This device complies with part 15 of the FCC Rules. Operation is subject to the following two conditions : (1) This device may not cause harmful interference, and (2) this device must accept any interference received, including interference that may cause undesired operation.

2.5 User Information

The users manual or instruction manual for an intentional or unintentional radiator shall caution the user that changes or modifications not expressly approved by the party responsible for compliance could void the user's authority to operate the equipment.

For a Class B digital device or peripheral, the instructions furnished the user shall include the following or similar statement, placed in a prominent location in the text of the manual.

The Federal Communications Commission Radio Frequency Interference Statement includes the following paragraph.

This equipment has been tested and found to comply with the limits for a Class B Digital Device, pursuant to Part 15 of the FCC Rules. These limits are designed to provide reasonable protection against harmful interference in a residential installation.

This equipment generates, uses and can radiate radio frequency energy and, if not installed and used in accordance with the instruction may cause harmful interference to radio communication. However, there is no guarantee that interference will not occur in a particular installation.

If this equipment does cause harmful interference to radio or television reception, which can be determined by turning the equipment off and on, the user is encouraged to try to correct the interference by one or more of the following measures:

- Reorient or relocate the receiving antenna.

- Increase the separation between the equipment and receiver.

- Connect the equipment into an outlet on a circuit different from that to which the receiver is connected.

- Consult the dealer or an experienced radio / TV technician for help.

3 SYSTEM TEST CONFIGURATION

3.1 Justification

All measurement were intentional to maximum the emissions from EUT by varying the connection cables, therefore, the test result is sure to meet the applicable requirement.

3.2 Devices for Tested System

Device	Manufacture	Model / FCC ID.	Description
RF Wireless Keyboard*	Dexin Corporation	RFKB0102 NIYRFKB0102	Tow AA Sized 1.5Volt Batteries.

Remark "*" means equipment under test.

4 RADIATED EMISSION MEASUREMENT

4.1 Applicable Standard

For intentional radiators, according to § 15.249 (a), operation within the frequency band of 2.4 to 2.4835 GHz, the fundamental field strength shall not exceed 94 dBuV/m and the harmonics shall not exceed 54 dBuV/m. For out band emission except for harmonics shall be comply with § 15.209 or at least attenuated by 50 dB below the level of the fundamental.

4.2 Measurement Procedure

1. Setup the configuration per figure 5 and 6 for frequencies measured below and above 1 GHz respectively.
2. For emission frequencies measured below 1 GHz, a pre-scan is performed in a shielded chamber to determine the accurate frequencies of higher emissions will be checked on a open test site. As the same purpose, for emission frequencies measured above 1 GHz, a pre-scan also be performed with a 1 meter measuring distance before final test.
3. For emission frequencies measured below and above 1 GHz, set the spectrum analyzer on a 100 kHz and 1 MHz resolution bandwidth respectively for each frequency measured in step 2.
4. The search antenna is to be raised and lowered over a range from 1 to 4 meters in horizontally polarized orientation. Position the highness when the highest value is indicated on spectrum analyzer, then change the orientation of EUT on test table over a range from 0 ° to 360 ° with a speed as slow as possible, and keep the azimuth that highest emission is indicated on the spectrum analyzer. Vary the antenna position again and record the highest value as a final reading. A RF test receiver is also used to confirm emissions measured.

Note : A band pass filter was used to avoid pre-amplifier saturated when measure TX operation mode in frequency band above 1 GHz.

5. Repeat step 4 until all frequencies need to be measured were complete.
6. Repeat step 5 with search antenna in vertical polarized orientations.
7. Check the three frequencies of highest emission with varying the placement of cables associated with EUT to obtain the worse case and record the result.

Figure 1 : Frequencies measured below 1 GHz configuration

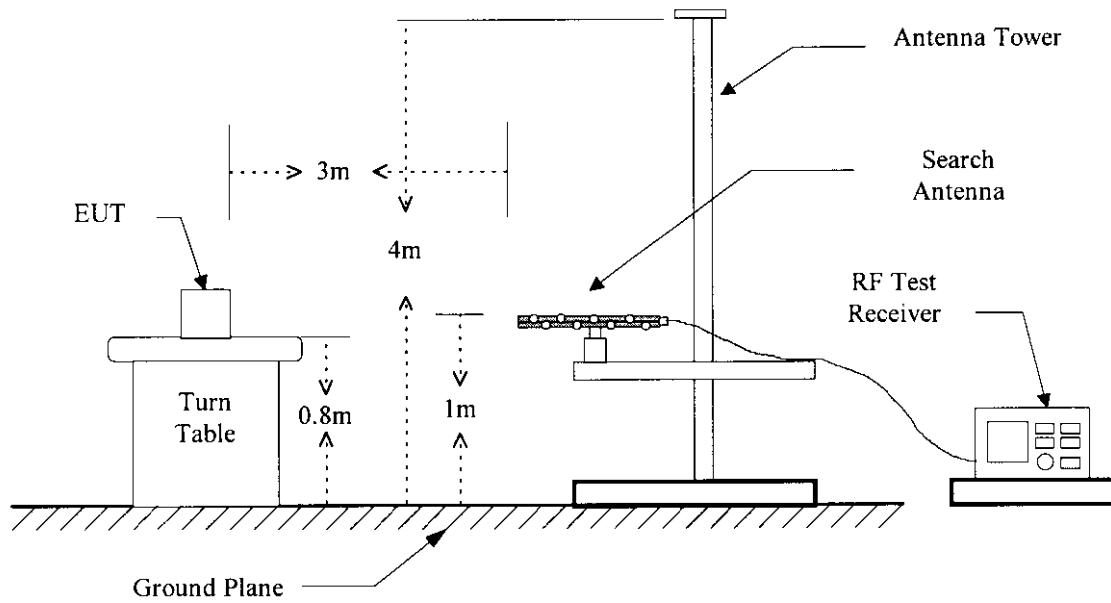
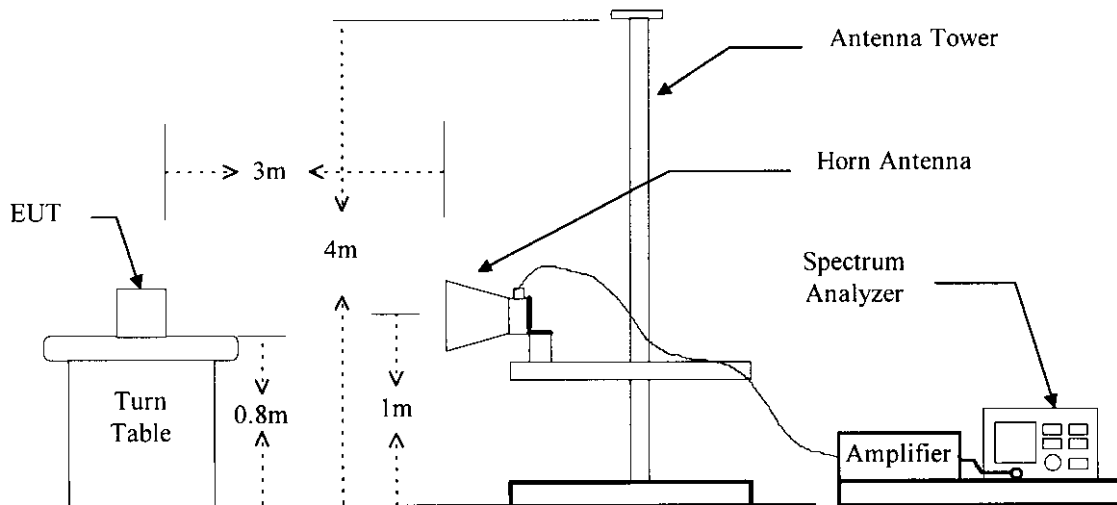

Figure 2 : Frequencies measured above 1 GHz configuration



4.3 Measuring Instrument

The following instrument are used for radiated emissions measurement :

Equipment	Manufacturer	Model No.	Next Cal. Date
Spectrum Analyzer	Hewlett-Packard	8568B	12/02/1999
Pre-selector	Hewlett-Packard	85685A	12/07/1999
Quasi Peak Detector	Hewlett-Packard	85650A	12/02/1999
RF Test Receiver	Rohde & Schwarz	ESVS 30	01/10/2000
RF Test Receiver	Rohde & Schwarz	ESBI	09/15/1999
Log periodic Antenna	EMCO	3146	09/15/1999
Biconical Antenna	EMCO	3110	09/15/1999
Horn Antenna	EMCO	3115	05/11/2000
Preamplifier	Hewlett-Packard	8447D	11/30/1999
Micro Wave EMI Test System	Hewlett-Packard	84125C	01/24/2000

Measuring instrument setup in measured frequency band when specified detector function is used :

Frequency Band (MHz)	Instrument	Function	Resolution bandwidth	Video Bandwidth
30 to 1000	RF Test Receiver	Quasi-Peak	120 kHz	N/A
	Spectrum Analyzer	Peak	100 kHz	100 kHz
Above 1000	Spectrum Analyzer	Peak	1 MHz	1 MHz
	Spectrum Analyzer	Average	1 MHz	300 Hz

4.4 Radiated Emission Data

Operation Mode : Transmitting

Fundamental Frequency : 916.690 MHz

Test Date : AUG. 24, 1999

Temperature : 23 °C

Humidity : 50 %

Frequency (MHz)	Reading (dBUV)				Factor (dB) Corr.	Result @3m (dBUV/m)		Limit @3m (dBUV/m)		Margin (dB)	Table Deg. (Deg.)	Ant. High (m)
	H		V			Peak	Ave	Peak	Ave.			
916.693	81.5	***	77.2	***	2.4	83.9	***	114.0	94.0	-10.1	0	1.50
1833.386	40.1	***	42.2	***	-5.6	36.6	***	74.0	54.0	-17.4	90	1.50
2750.079	51.5	***	51.4	***	-1.9	49.6	***	74.0	54.0	-4.4	180	1.50
3666.772	48.4	***	46.9	***	0.7	49.1	***	74.0	54.0	-4.9	90	1.30
4583.465	---	---	---	---	2.2	---	---	74.0	54.0	---	---	---
5500.158	41.7	***	46.9	***	4.4	51.3	***	74.0	54.0	-2.7	90	1.50
6416.851	---	---	---	---	4.5	---	---	74.0	54.0	---	---	---
7333.544	---	---	---	---	5.9	---	---	74.0	54.0	---	---	---
8250.237	---	---	---	---	6.6	---	---	74.0	54.0	---	---	---
9166.930	---	---	---	---	7.1	---	---	74.0	54.0	---	---	---

Note :

1. Item of margin shown in above table refer to average limit.
2. It is considered that the results of average comply with average limit when measuring data with a peak function detector meet the average limit. Mark “***” means that Peak result is meet average limit.
3. Remark “---” means that the emissions level is too low to be measured.
4. Item “Margin” referred to Average limit while there is only peak result.

4.5 Field Strength Calculation

The field strength is calculated by adding the Antenna Factor, High Pass Filter Loss(if used) and Cable Loss, and subtracting the Amplifier Gain (if any) from the measured reading. The basic equation calculation is as follows:

$$Result = Reading + Corrected Factor$$

where Corrected Factor

$$= Antenna FACTOR + Cable Loss + High Pass Filter Loss - Amplifier Gain$$

5. CONDUCTED EMISSION MEASUREMENT

5.1 Standard Applicable

This EUT is excused from investigation of conducted emission, for it is powered by battery only. According to § 15.207 (d), measurements to demonstrate compliance with the conducted limits are not required for devices which only employ battery power for operation and which do not operate from the AC power lines or contain provisions for operation while connected to the AC power lines.

6 ANTENNA REQUIREMENT

6.1 Standard Applicable

According to § 15.203, an intentional radiator shall be designed to ensure that no antenna other than that furnished by the responsible party shall be used with the device.

6.2 Antenna Construction

The antenna is permanently mounted on RF box, no consideration of replacement.

7 BAND EDGES MEASUREMENT

7.1 Standard Applicable

According to 15.249(c), out band emission except for harmonics shall be comply with § 15.209 or at least attenuated by 50 dB below the level of the fundamental.

7.2 Measurement Procedure

1. Check the calibration of the measuring instrument using either an internal calibrator or a known signal from an external generator.
2. Position the EUT as shown in figure 4 without connection to measurement instrument. Turn on the EUT and connect its antenna terminal to measurement instrument via a low loss cable. Then set it to any one measured frequency within its operating range and make sure the instrument is operated in its linear range.
3. Set both RBW and VBW of spectrum analyzer to 100 kHz with a convenient frequency span including 100kHz bandwidth from band edge.
4. Measure the highest amplitude appearing on spectral display and set it as a reference level. Plot the graph with marking the highest point and edge frequency.
5. Repeat above procedures until all measured frequencies were complete.

7.3 Measurement Equipment

Equipment	Manufacturer	Model No.	Next Cal. Date
EMI Test Receiver	Rohde & Schwarz	ESBI	09/15/1999
Plotter	Hewlett-Packard	7440A	N/A

7.4 Measurement Data

Test Date : AUG. 24, 1999 Temperature : 23 °C Humidity: 50 %

Please see following pages of plotted data.



Date 24.Aug.'99 Time 10:48:39
Ref.Lvl 95.00 dBuV
Marker 80.00 dBuV
916.96 MHz

Res.BW 100 kHz [imp]
TG.Lvl Off
CF.Stp 3.000 MHz

Vid.BW 100 KHz
RF.Att 0 dB
Unit [dBuV]

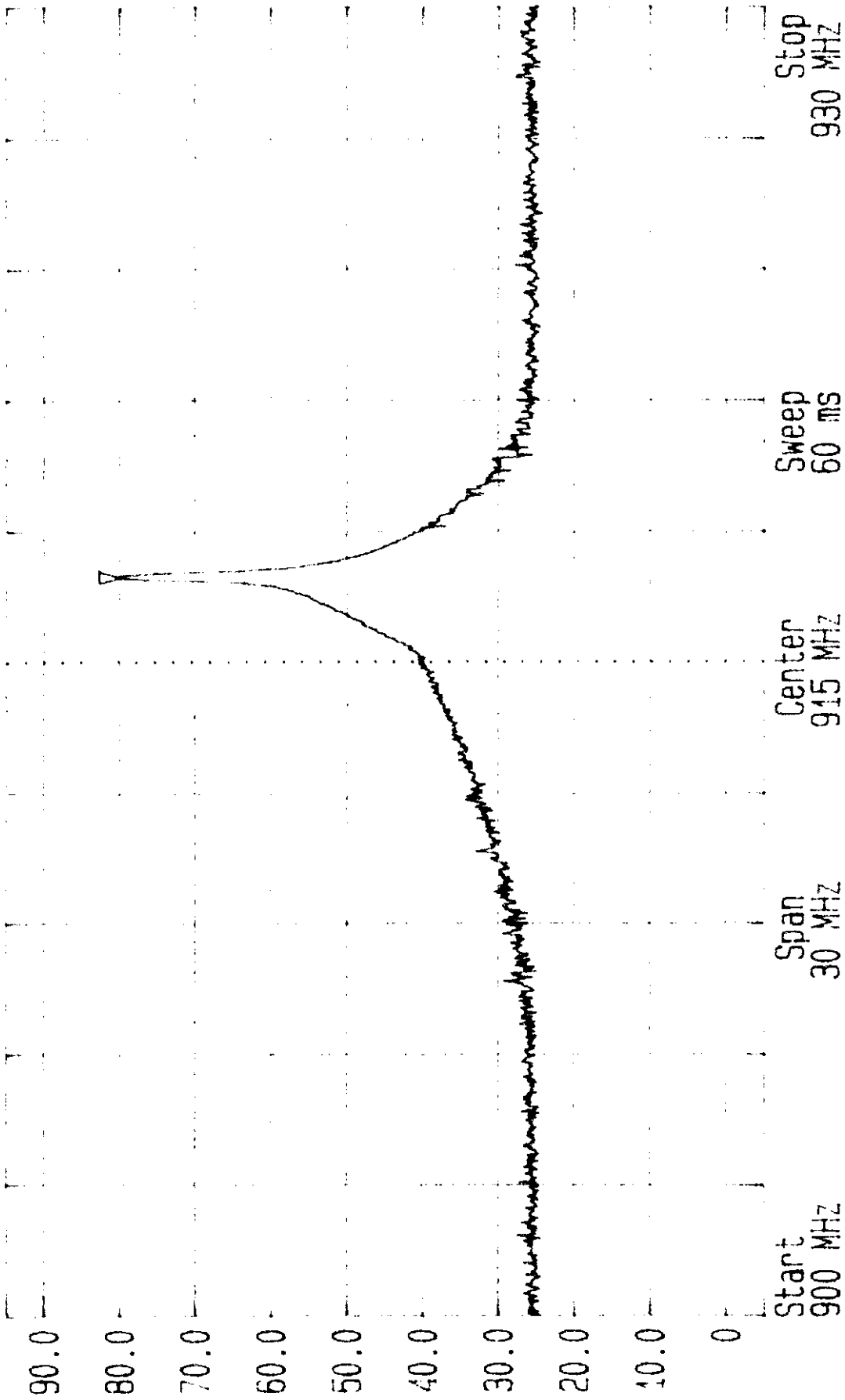

For intentional radiator device, per § 15.249(a), the field strength of emissions shall comply with the following :

Frequency MHz	Distance Meters	Fundamental		Harmonic	
		dB μ V/m	mV/m	dB μ V/m	μ V/m
902 - 928	3	94	50	54	500
2400 - 2483.5	3	94	50	54	500
5725 - 5875	3	94	50	54	500
24000 - 24250	3	108	250	68	2500

In accordance with § 15.249(d), limits shown in above table are based on average limits for frequencies above 1000 MHz, and frequencies below 1000 MHz are based on quasi peak. However, the peak field strength of any emission shall not exceed the maximum permitted average limits by more than 20 dB.

(3) Spurious in Out Band Requirement

For intentional device, according to § 15.249 (c), emissions radiated outside of the specified frequency bands, except for harmonics, shall be attenuated by at least 50 dB below the level of fundamental or to the general radiated emission limits in § 15.209.

(4) Antenna Requirement

For intentional device, according to § 15.203, an intentional radiator shall be designed to ensure that no antenna other than that furnished by the responsible party shall be used with the device.