



**Certelec Laboratories Inc.**

*Safety - EMI - Telecom - ISO Guide 25*

---

**ENGINEERING TEST REPORT**

**ON:  
THE ELECTRA ENTERPRISES  
"VID-906 VIDEO TRANSMITTER"**

**FCC ID: NIMT906**

**IN ACCORDANCE WITH:  
FCC PART 15, SUBPART C  
PARAGRAPH 15.249  
902-928 MHz TRANSMITTERS**

**PROJECT NO.: 8R00260**

**TESTED FOR:**

ELECTRA ENTERPRISES  
390 EDGELEY BLVD., UNIT 21  
CONCORD, ONTARIO  
L4K 3Z6

**TESTED BY:**

CERTELECOM LABORATORIES INC.  
3325 RIVER ROAD, R.R. 5  
OTTAWA, ONTARIO K1V 1H2

APRIL 1998

This document contains 12 pages including this one.

Certelec Laboratories Inc. authorizes the above named company to reproduce this report provided it is reproduced in its entirety and for use by the company's employees only.

Any use which a third party makes of this report, or any reliance on or decisions to be made based on it, are the responsibility of such third parties. Certelec Laboratories Inc. accepts no responsibility for damages, if any, suffered by any third party as a result of decisions made or actions based on this report.

This report applies only to the items tested.

*EQUIPMENT: VID-906 Video Transmitter*  
*FCC ID: NIMT906*

---

EQUIPMENT DESCRIPTION: The E.U.T. is an analog video transmitter that operates at 906 MHz

MODEL NO.: VID-906

SERIAL NO.: None

**GENERAL:**

These tests were conducted on a sample of the equipment for the purpose of demonstrating compliance with FCC Part 15 Subpart C, Paragraph 15.249 for Intentional Radiators operating within the frequency band 902 - 928 MHz.

**ABSTRACT:**

NAME OF TEST	PARA. NO.	RESULTS
Radiated Emissions	15.249(a)	Complies
Powerline Conducted Emissions	15.207(a)	Not Applicable

THIS TEST REPORT RELATES ONLY TO THE ITEM(S) TESTED.

THE FOLLOWING DEVIATIONS FROM, ADDITIONS TO, OR EXCLUSIONS FROM THE TEST SPECIFICATIONS HAVE BEEN MADE. None

It is recommended that the margin of compliance be improved to allow for manufacturing tolerances.

TESTED BY: *Tom Tidwell*  
Tom Tidwell, Senior Technologist

DATE: *7 May 1998*

APPROVED BY: *W. Waterhouse*  
W. Waterhouse, RF Engineering Lab Manager

DATE: *7th May 1998*

*EQUIPMENT: VID-906 Video Transmitter*  
*FCC ID: NIMT906*

---

**General Equipment Information**

**TRANSMITTER**

Frequency Range:	906 Fixed
Frequency of Sample Tested:	906 MHz
Tunable Bands:	N/A
Number of Channels:	N/A
Channel Spacing:	N/A
Emission Designator:	49C303F
Crystal Frequencies:	N/A
User Frequency Adjustment:	N/A
Necessary Bandwidth:	49.3 kHz

*EQUIPMENT: VID-906 Video Transmitter*

*FCC ID: NIMT906*

---

CONFIGURATION OF EQUIPMENT UNDER TEST

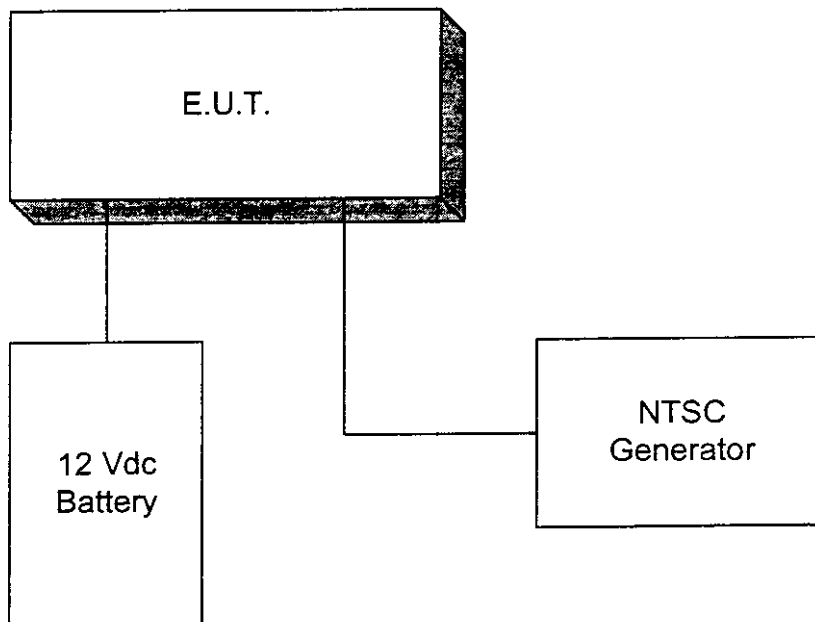

EQUIPMENT: VID-906 Video Transmitter  
FCC ID: NIMT906

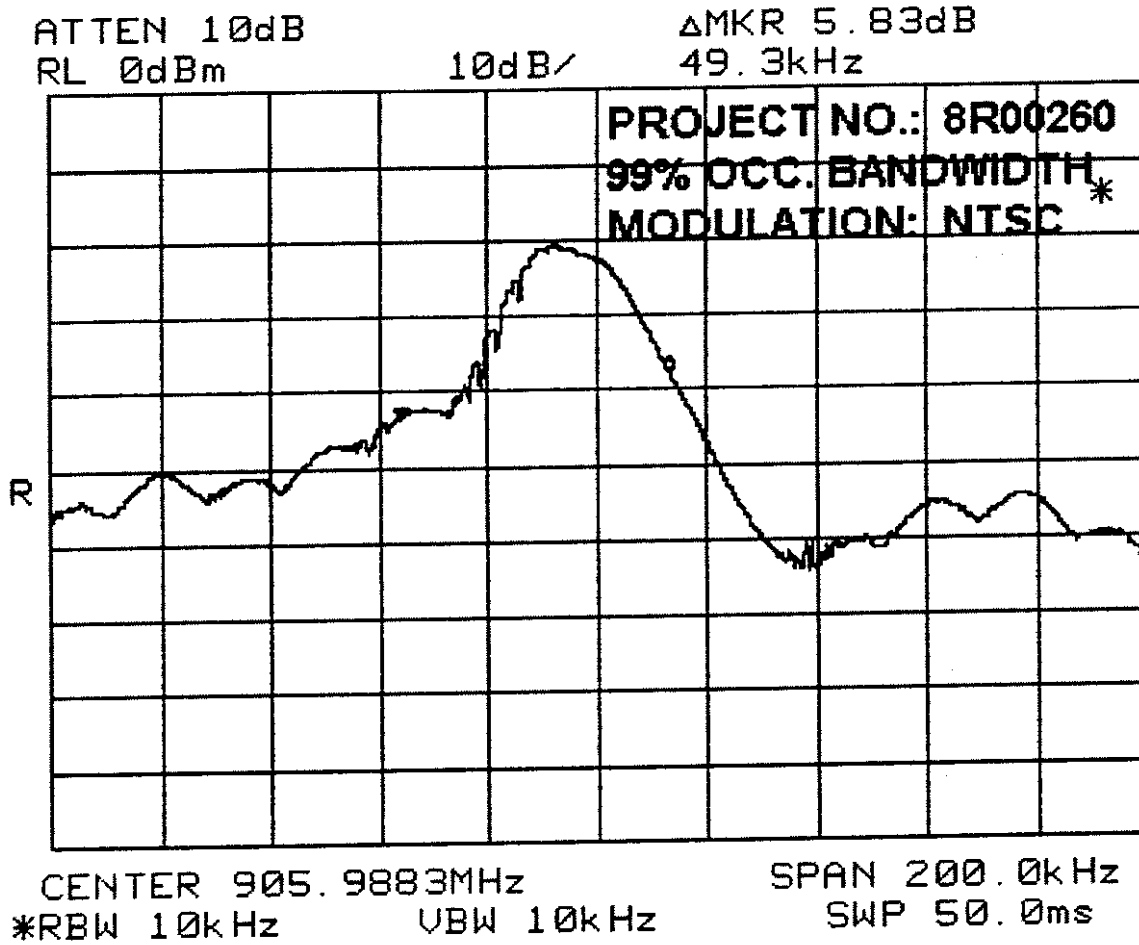

EQUIPMENT: VID-906 Video Transmitter

FCC ID: NIMT906

\*ATTEN 0dB  
RL 0dBm

10dB/

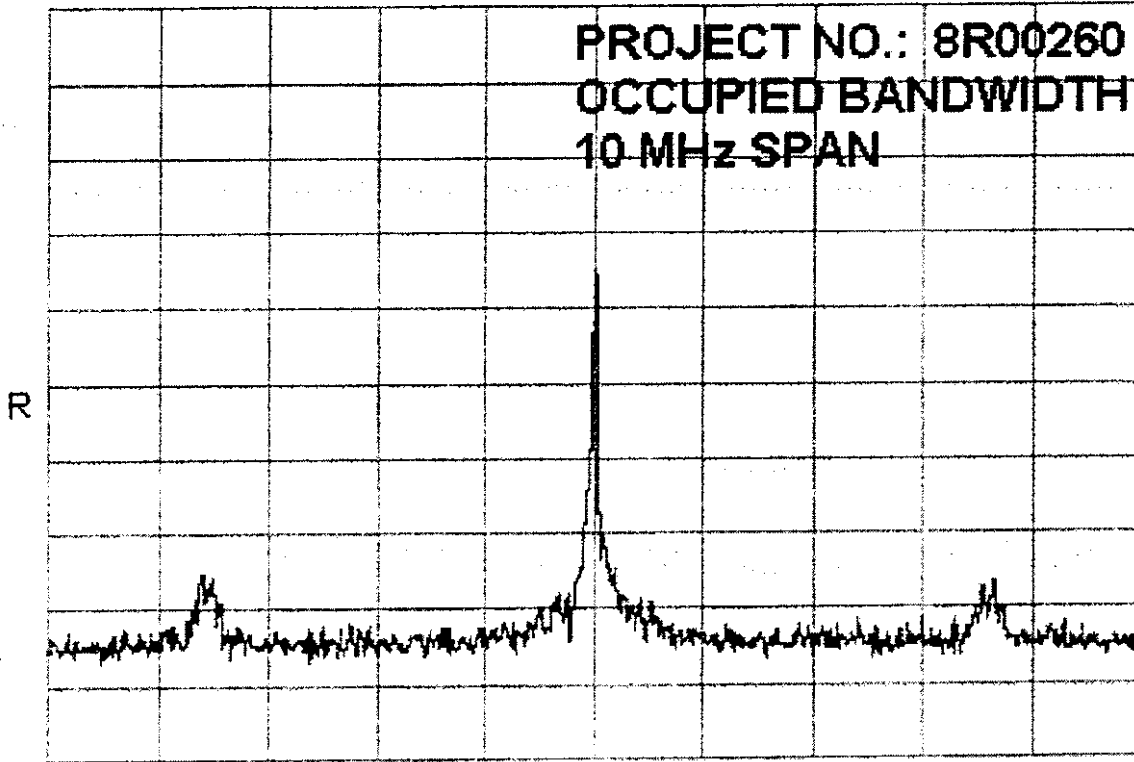

START 900.98MHz      STOP 910.98MHz  
\*RBW 10kHz      VBW 10kHz      SWP 250ms

EQUIPMENT: VID-906 Video Transmitter  
FCC ID: NIMT906

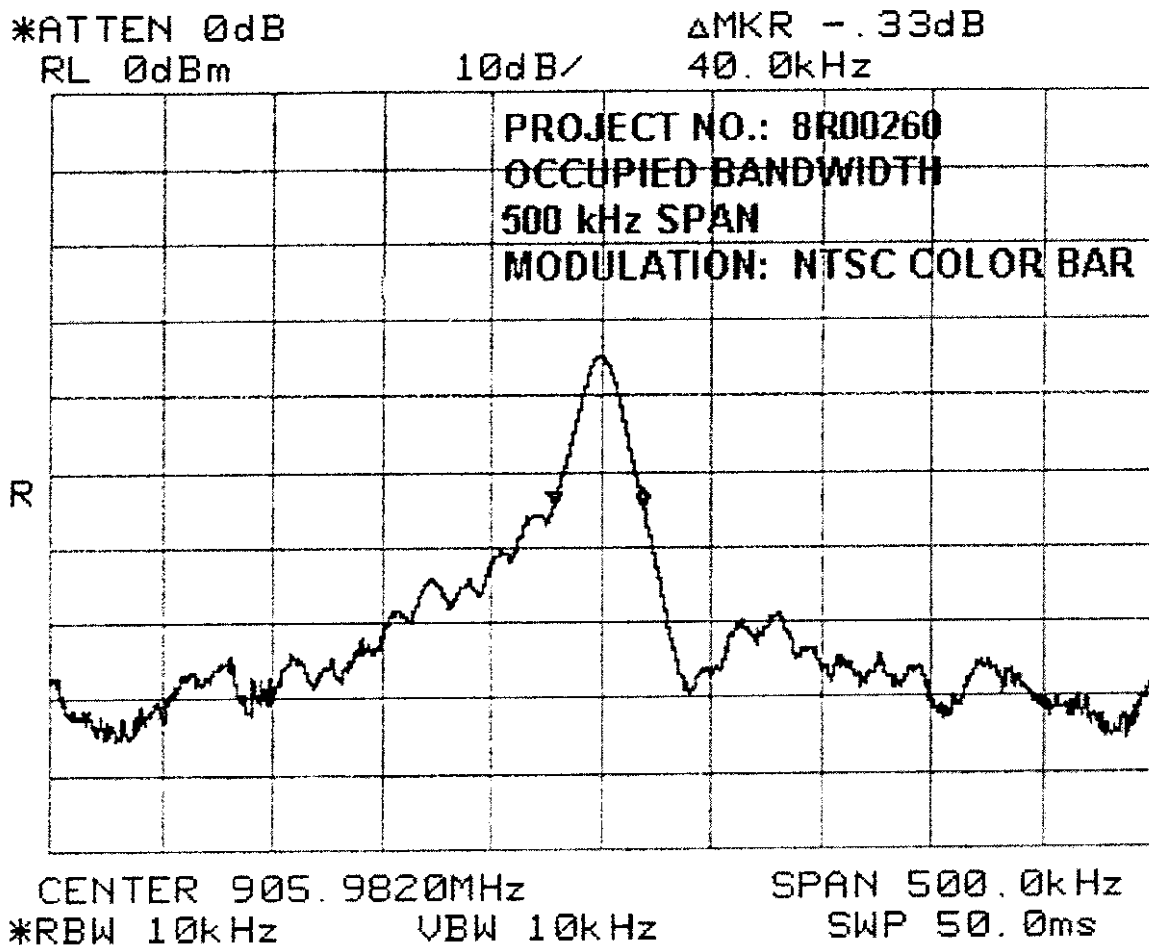

*EQUIPMENT: VID-906 Video Transmitter*  
*FCC ID: NIMT906*

NAME OF TEST: Radiated Emissions	PARA. NO.: 15.249(a) & (c)
TESTED BY: Tom Tidwell	DATE: April 17, 1998

TEST CONDITIONS:      Temperature and Humidity: 20°, 24°  
                                  Test Voltage: 9 Vdc

MINIMUM STANDARD:

Fundamental Frequency (MHz)	Field Strength of Fundamental (mV/m @ 3m)	Field Strength of Fundamental (dBµV/m @ 3m)	Field Strength of Spurious (µV/m @ 3m)	Field Strength of Spurious (dBµV/m @ 3m)
902 - 928	50	94	500	54

Any emissions radiated outside the specified frequency band, except for harmonics shall be attenuated by at least 50 dB below the level of the fundamental emission or meet the following limits, whichever is the lesser attenuation.

Frequency (MHz)	Field Strength (µV/m @ 3m)	Field Strength (dB @ 3m)
30 - 88	100	40.0
88 - 216	150	43.5
216 - 960	200	46.0
Above 960	500	54.0

TEST RESULTS:      Complies. The worst-case emission level is 52.5 dBµV/m @ 3m at 2718 MHz. This is 1.5 dB below the specification limit.

MEASUREMENT DATA:      See attached table.



*EQUIPMENT: VID-906 Video Transmitter*

*FCC ID: NIMT906*

TESTED BY: Tom Tidwell		DETECTOR: As per table									
DATE: April 17, 1998		TEST DISTANCE(metres): 3									
E.U.T. MODEL NO.: VID-906		TEST RECEIVER: As per table									
E.U.T. S/N: None		RECEIVER BW: As per table									
FREQ. (MHz)	ANT. *	POL. (V/H)	BW & Det **	TABLE AZIMUTH (Degrees)	RECEIVED SIGNAL (dBuV)	ANTENNA FACTOR (dB)**	AMP GAIN (dB)***	DIST. CORR.	FIELD STRENGTH (dBuV/m)	LIMIT (dBuV/m)	MARGIN (dB)
906.0	E/D4	V	3		56.8	34.5			91.3	94.0	2.7
906.0	E/D4	H	3		52.2	34.5			86.7	94.0	7.3
1812.0	Hm2	V	5		65.8	30.9	-45.8		50.9	74.0	23.1
1812.0	Hm2	H	5		60.8	30.9	-45.8		45.9	74.0	28.1
2718.0	Hm2	V	5		64.5	33.9	-45.9		52.5	54.0	1.5
2718.0	Hm2	H	5		63.4	33.9	-45.9		51.4	54.0	2.6
3624.0	Hm2	V	5		52.0	40.2	-45.2		47.0	74.0	27.0
3624.0	Hm2	H	5		52.4	40.2	-45.2		47.4	74.0	26.6
4530.0	Hm2	V	5		52.8	39.8	-45.5		47.1	74.0	26.9
4530.0	Hm2	H	5		51.2	39.8	-45.5		45.5	74.0	28.5
5436.0	Hm2	V	5		48.7	42.6	-45.7		45.6	74.0	28.4
5436.0	Hm2	H	5		44.2	42.6	-45.7		41.1	74.0	32.9

**NOTES:**

B/C = Biconical, B/L = Biconilog, L/P = Log-Periodic, H = Horn, D/P = Dipole

\* Re-Measured using dipole antenna. () Denotes failing emission

\*\* (1) 120 kHz, Q-Peak, (2) 10 kHz, Peak, (3) 100 kHz RBW, 300 kHz VBW, (4) 300 kHz RBW, 1 MHz VBW, (5) 1 MHz RBW, 1 MHz VBW, (6) 1 MHz RBW, 10 Hz VBW, (7) 3 MHz RBW, 3 MHz VBW

*EQUIPMENT: VID-906 Video Transmitter*  
*FCC ID: NIMT906*

---

NAME OF TEST: Powerline Conducted Emissions	PARA. NO.: 15.207(a)
TESTED BY:	DATE:

TEST CONDITIONS: Standard Temperature and Humidity  
Standard Test Voltage

MINIMUM STANDARD: The R.F. that is conducted back onto the A power line on any frequency within the band 0.45 to 200 kHz shall not exceed 250µV (48 dBµV) across 50 ohms.

TEST RESULTS: Complies/Does Not Comply. See attached graphs.

MEASUREMENT DATA: See attached graphs.

**NOT APPLICABLE**

*EQUIPMENT: VID-906 Video Transmitter*  
*FCC ID: NIMT906*

---

TEST SITE FOR RADIATED EMISSIONS

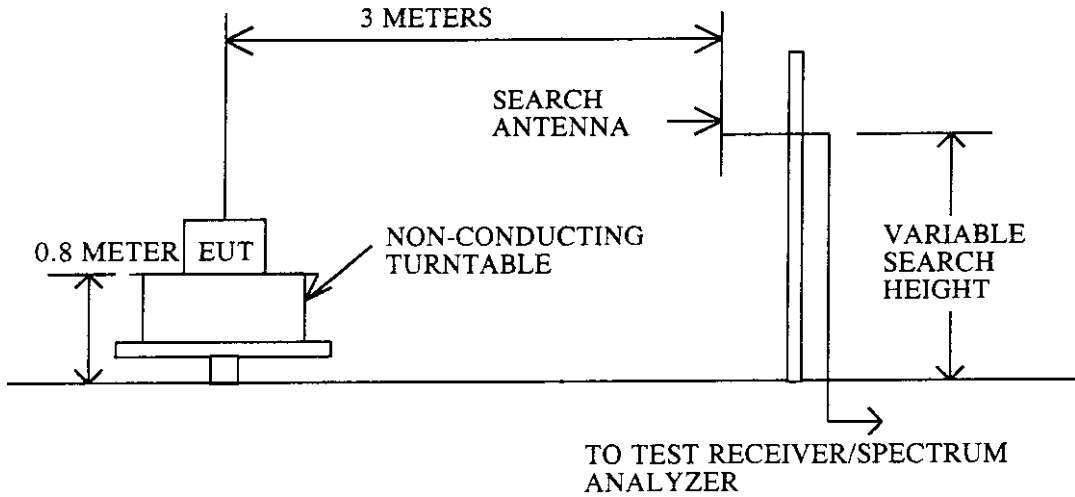

CONDUCTED EMISSIONS

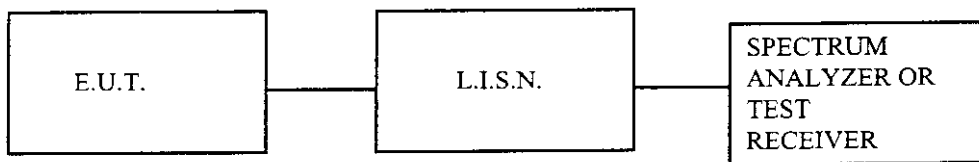

SHIELDED ROOM

*EQUIPMENT: VID-906 Video Transmitter*  
*FCC ID: NIMT906***TEST EQUIPMENT LIST****Equipment List - Radiated Emissions**

CAL Cycle	Equipment	Manufacturer	Model #	Serial/Asset #	Last Cal.	Next Cal.
1 Year	Dipole Antenna Set	EMCO	3121C	1029	Oct. 28/97	Oct. 28/98
1 Year	Receiver	Rohde & Schwarz	ESVP	892661/014	Mar. 31/98	Mar. 31/99
1 Year	Spectrum Analyzer	Hewlett-Packard	8565E	FA000981	May 9/97	May 9/98
	Plotter	Hewlett Packard	7470A	2210A08836	N/A	N/A
1 Year	Biconical (!) Antenna	EMCO	3109	9204-2708	July 11/97	July 11/98
2 Year	Horn Antenna	EMCO	3115	4336	Oct. 30/97	Oct. 30/99
1 Year	Log Periodic Antenna	EMCO	LPA-25	1141	July 10/97	July 10/98
1 Year	Low Noise Amplifier	Avantek	AWT-8035	1005	Oct. 24/97	Oct. 24/98

Note: N/A = Not Applicable  
NCR = No Cal Required