

# RF Maximum Permissible Exposure Measurement Report

of

E.U.T. : SST Cordless Phone (Base Unit)

MODEL : SN-920 ULTRA

FCC ID. : NI3-SN-920U

for

APPLICANT : SENA INTERNATIONAL CO., LTD.

ADDRESS : 2FL, NO. 531 CHUNG CHENG RD., HSIN-TIEN CITY,  
TAIPEI HSIEN, TAIWAN, R.O.C.

Test Performed by

**ELECTRONICS TESTING CENTER, TAIWAN**

NO. 8 LANE 29, WENMIMG ROAD,  
LOSHAN TSUN, KWEISHAN HSIANG,  
TAOYUAN, TAIWAN, R.O.C.

Tel:(03)3280026-32

Fax:(03)3280034

Report Number : ET88R-12-069

# TEST REPORT CERTIFICATION

Applicant : SENAO INTERNATIONAL CO., LTD.  
2FL, NO. 531 CHUNG CHENG RD., HSIN-TIEN CITY, TAIPEI  
HSIEN, TAIWAN, R.O.C.

Manufacturer : SENAO INTERNATIONAL CO., LTD.  
2FL, NO. 531 CHUNG CHENG RD., HSIN-TIEN CITY, TAIPEI  
HSIEN, TAIWAN, R.O.C.

Description of EUT :

a) Type of EUT : SST Cordless Phone  
b) Model No. : SN-920 ULTRA  
c) FCC ID. : NI3-SN-920U  
d) Power Supply : AC Adapter( I/P:120V/60Hz, O/P:9Vdc 600mA)

Regulation Applied : IEEE C95.1-1991, FCC 47 CFR Part 1 and Part 2

I HEREBY CERTIFY THAT: The data shown in this report were made in accordance with the procedures given in IEEE C95.1, and the energy emitted by the device was founded to be within the limits applicable. I assume full responsibility for accuracy and completeness of these data.

Note: 1. The result of the testing report relates only to the item tested.  
2. The testing report shall not be reproduced expect in full, without the written approval of ETC.

Issued Date : Jan. 30, 2000

Test Engineer :   
( K. C. Chen )

Approve & Authorized Signer :   
Will Yauo, Supervisor  
EMI Test Site of ELECTRONICS  
TESTING CENTER, TAIWAN

<b>Table of Contents</b>		<b>Page</b>
<b>1</b>	<b>GENERAL INFORMATION</b>	<b>1</b>
1.1	Product Description	1
1.2	Characteristics of Device	1
1.3	Test Methodology	1
1.4	Test Facility	1
<b>2</b>	<b>PROVISIONS APPLICABLE</b>	<b>2</b>
2.1	Definition	2
2.2	Relative Requirement for Compliance	2
<b>3</b>	<b>SYSTEM TEST CONFIGURATION</b>	<b>3</b>
3.1	Justification	3
3.2	Devices for Tested System	3
<b>4</b>	<b>MAXIMUM PERMISSIBLE EXPOSURE MEASUREMENT</b>	<b>4</b>
4.1	Applicable Standard	4
4.2	Measurement Procedure	4
4.3	Measurement Instrument	5
4.4	Power Density Data	5
<b>APPENDIX A</b>	<b>SPECIFICATION OF DEVICE UNDER TEST</b>	<b>6</b>

# 1 GENERAL INFORMATION

## 1.1 Product Description

- a) Type of EUT : SST Cordless Phone
- b) Trade Name : EnGenius
- c) Model No. : SN-920 ULTRA
- d) Power Supply : AC Adapter( I/P:120V/60Hz, O/P:9Vdc 600mA)

## 1.2 Characteristics of Device

The SST Cordless Phone using the frequency hopping spread spectrum technology. The base unit plugs into a standard analogue telephone jack and provides a digital wireless communication link with the handset using the 920 to 928 ISM band. It automatically hops to different frequencies over 200 times per second. And the modulation is the binary FSK type. For more details of specification, please see appendix A.

## 1.3 Test Methodology

The Maximum Permissible Exposure (MPE) was performed according to the procedures illustrated in IEEE C95.1-1991.

## 1.4 Test Facility

The open area test site and conducted measurement facility used to collect the radiated data is located on the roof top of Building at No.34, 5 Lirn, Din Fu Tsun, Lin Kou, Taipei, Taiwan, R.O.C.

This site has been fully described in a report submitted to the FCC, and accepted in a letter dated Feb. 10, 1997.

## 2 PROVISIONS APPLICABLE

### 2.1 Definition

#### MPE in Occupational / Controlled Environments:

Persons are exposed as a consequence of their employment provided those persons are fully aware of the potential for exposure and can exercise control over their exposure. Also apply to a individual is transient through a location where occupational / controlled limits apply provided he or she is made aware of the potatial for exposure.

#### MPE in General Population / Uncontrolled Environments:

General population / Uncontrilled exposure apply in situation in which the general public may be exposed, or in which persons that are exposed as a consequence of their employment may not be fully aware of the potatial for exposure or cannot excercise control over their exposure.

### 2.2 Relative Requirement for Compliance

#### (1) MPE for Controlled Enviroments

According to section 1.1310 of FCC 47 CFR Part 1, MPE Limits for controlled enviroment are as following:

Frequency Range (MHz)	Electric Field Strength (V/m)	Magnetic Field Strength (A/m)	Power Density (mW/cm <sup>2</sup> )	Averaging Time (minutes)
0.3-3.0	614	1.63	*100	6
3-30	1842/f	4.89/f	*900/f <sup>2</sup>	6
30-300	61.4	0.163	1.0	6
300-1500	-----	-----	f/300	6
15000-100,000	-----	-----	5.0	6

#### (2) MPE for Uncontrolled Enviroments

According to section 1.1310 of FCC 47 CFR Part 1, MPE Limits for uncontrolled enviroment are as following:

Frequency Range (MHz)	Electric Field Strength (V/m)	Magnetic Field Strength (A/m)	Power Density (mW/cm <sup>2</sup> )	Averaging Time (minutes)
0.3-3.0	614	1.63	*100	30
3-30	1842/f	4.89/f	*180/f <sup>2</sup>	30
30-300	27.5	0.073	0.2	30
300-1500	-----	-----	f/1500	30
15000-100,000	-----	-----	1.0	30

f = frequency in MHz

\* = Plane-wave equivalent power density

### 3. SYSTEM TEST CONFIGURATION

#### 3.1 Justification

The system was configured for testing in a typical fashion, as a customer would normally use it. But for MPE testing, because of the emission type of EUT is frequency hopping technique, a firmware from the manufacturer is employed to set the EUT in maximum output power and fix the transmitting frequency of EUT. The output power was also verified with a spectrum analyzer. The peripherals other than EUT were connected in normally standing by situation. Hereby, we can make sure that the MPE testing was performed under the worst case.

#### 3.2 Devices for Tested System

<u>Device</u>	<u>Manufacture</u>	<u>Model</u>	<u>Cable Description</u>
SST Cordless Phone *	SENAO INTERNATIONAL CO., LTD.	SN-920 ULTRA	3m telephone line AC Adaptor cord 1.8m

Remark “\*” means device under test.

## 4 Maximum Permissible Exposure Measurement

### 4.1 Applicable Standard

For this intentional radiator are used with any possible people, therefore the **Uncontrolled Environment Condition** is applied. And the MPE requirement is as described in section 2.2 of this test report.

### 4.2 Measurement Procedure

- (1) Set up the device under test (DUT) as its normal using configuration. Please see figure 1.
- (2) Calibrate the probe system so that the meter displays zero, and then power on the DUT.
- (3) Scan the antenna of DUT with a proper spacer of 5 cm in vertical axis and keep vertical scanning around the antenna, and pick up the maximum data with Max. Hold function.
- (4) Repeat step (3) by changing the spacer to 10 cm and then 20 cm till the field from DUT is too weak to be measured.
- (5) Record the maximum value appeared.

Figure 1 : Measurement configuration

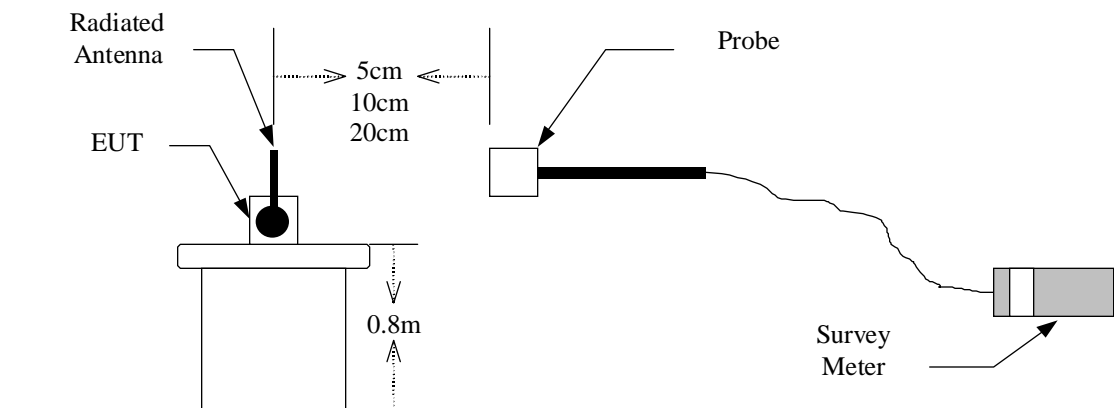

### 4.3 Measurement Instrument

The following instrument are used for radiated emissions measurement :

Equipment	Manufacturer	Model No.	Next Cal. Due
Survey Meter	Narda	8712	Jan. 30, 2001
Probe	Narda	8721D	Jan. 30, 2001

### 4.4 Power Desity Data

Operation Mode : Maximum Data Transmitting Rate  
 Transmitting Frequency : 902 to 928 MHz  
 Rated Maximum Output Power : 29.5 dBm  
 Measured Output Peak Power : 29.65 dBm@ 902 MHz, 29.62 dBm @ 915 MHz, 29.5 dBm @ 928 dBm  
 Test Date : Jan. 15, 2000      Temperature : 22 •      Humidity : 72%

Measured Frequency MHz	Measured @ 5cm mW/cm <sup>2</sup>	Measured @ 10cm mW/cm <sup>2</sup>	Measured @ 20cm mW/cm <sup>2</sup>	Measured @ 30cm mW/cm <sup>2</sup>	Probe Factor	Maximum Result mW/ cm <sup>2</sup>	MPE Limt mW/cm <sup>2</sup>
902.0	0.46	0.17	0.05	---	0.819	0.37	0.60
915.0	0.48	0.24	0.04	---	0.819	0.39	0.61
928.0	0.50	0.18	0.05	---	0.819	0.41	0.62

Note :

1. Remark “---” means that the emission level is too low to be measured (the precise accuracy of the measurement system is 0.01 mW/ cm<sup>2</sup>).
2. Value 0.819 is a corrected factor of measurement system.
3. Result = Value Measured X Corrected Factor.
4. The measurement was performed under the condition of fixed the emission frequency to get the most extreme MPE.



## **Appendix A    Specification of Device Under Test**