

APPLICATION FOR CERTIFICATION

On Behalf of

Powertech Industrial Co Ltd

Green Power Surge Protector

Model No. : (1)R9P602O300 (2)R9P603O300 (3)R9P602O3TO
(4)R9P603O3TO (5)R9P602O3D1 (6)R9P603O3D1

FCC ID : NHS-R9P602

Prepared for : Powertech Industrial Co Ltd
10F, No. 407, Chung Shan Rd., Sec 2
Chung Ho City, Taipei Hsien, 235 Taiwan

Prepared by : AUDIX Technology Corporation
EMC Department
No. 53-11, Tin-Fu Tsun, Lin-Kou Hsiang,
Taipei Hsien, Taiwan

Tel : (02) 2609-9301, 2609-2133

Fax: (02) 2609-9303

File Number : C1M1009158
Report Number : EM-F990985
Date of Test : Sep. 29 ~ Oct. 29, 2010
Date of Report : Oct. 29, 2010

TABLE OF CONTENTS

Description	Page
TEST REPORT CERTIFICATION	3
1. GENERAL INFORMATION	4
1.1. Description of Device (EUT).....	4
1.2. Description of Test Facility	5
1.3. Measurement Uncertainty	5
2. POWERLINE CONDUCTED EMISSION MEASUREMENT	6
2.1. Test Equipment	6
2.2. Block Diagram of Test Setup.....	6
2.3. Powerline Conducted Emission Limit (§15.207).....	6
2.4. Operating Condition of EUT	7
2.5. Test Procedure	7
2.6. Powerline Conducted Emission Measurement Results.....	7
3. RADIATED EMISSION MEASUREMENT	10
3.1. Test Equipment	10
3.2. Test Setup	10
3.3. Radiated Emission Limits (§15.209)	11
3.4. Fundamental Frequency Limits (§15.249).....	11
3.5. Operating Condition of EUT	12
3.6. Test Procedure	12
3.7. Radiated Emission Measurement Test Results	13
4. DEVIATION TO TEST SPECIFICATIONS.....	22
5. PHOTOGRAPHS.....	23
5.1. Photos of Powerline Conducted Emission Measurement	23
5.2. Photos of Radiated Emission Measurement at Semi-Anechoic Chamber	24

TEST REPORT CERTIFICATION

Applicant : Powertech Industrial Co Ltd
 EUT Description : Green Power Surge Protector
 FCC ID : NHS-R9P602
 (A) MODEL NO. : (1)R9P602O300 (2)R9P603O300
 (3)R9P602O3TO (4)R9P603O3TO
 (5)R9P602O3D1 (6)R9P603O3D1
 (B) SERIAL NO. : N/A
 (C) POWER SUPPLY : AC 125V
 (D) TEST VOLTAGE : AC 120V/60Hz

Measurement Procedure Used:

FCC RULES AND REGULATIONS PART 15 SUBPART C, October 2009
 AND ANSI C63.4/2003

(FCC CFR 47 Part 15C, §15.207, §15.249, §15.209)

The device described above was tested by AUDIX Technology Corporation to determine the maximum emission levels emanating from the device. The maximum emission levels were compared to the FCC Part 15 subpart C limits.

The measurement results are contained in this test report and AUDIX Technology Corporation is assumed full responsibility for the accuracy and completeness of these measurements. Also, this report shows that the EUT to be technically compliant with the FCC official limits.

This report applies to above tested sample only. This report shall not be reproduced in part without written approval of AUDIX Technology Corporation.

Date of Test : Sep. 29 ~ Oct. 29, 2010 Date of Report : Oct. 29, 2010

Producer : 
 (Julie Hsu/Administrator)

Reviewer : 
 (Henning Chang/Supervisor)

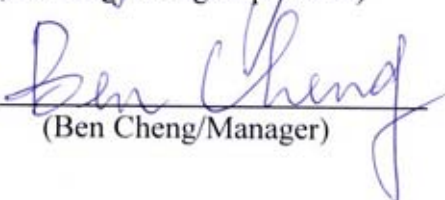
Signatory: 
 (Ben Cheng/Manager)

1. GENERAL INFORMATION

1.1. Description of Device (EUT)

Description : Green Power Surge Protector
(Transceiver)

FCC ID : NHS-R9P602

Model Number : (1)R9P602O300 (2)R9P603O300
(3)R9P602O3TO (4)R9P603O3TO
(5)R9P602O3D1 (6)R9P603O3D1

The models differences are as follow:

Item		Model		
With Relay	single	R9P602O300	R9P602O3TO	R9P602O3D1
	Package	R9P619O300 {R9P602O300 + R9P014 (FCC ID: NHS-R9P014)}	R9P619O3TO {R9P602O3TO + R9P014 (FCC ID: NHS-R9P014)}	R9P619O3D1 {R9P602O3D1 + R9P014 (FCC ID: NHS-R9P014)}
	Package	R9P620O300 {R9P602O300 + R9P014 (FCC ID: NHS-R9P014) + R9P125NI00 (FCC ID: NHS-R9P125)}	R9P620O3TO {R9P602O3TO + R9P014 (FCC ID: NHS-R9P014) + R9P125NI00 (FCC ID: NHS-R9P125)}	R9P620O3D1 {R9P602O3D1 + R9P014 (FCC ID: NHS-R9P014) + R9P125NI00 (FCC ID: NHS-R9P125)}
Without Relay	single	R9P603O300	R9P603O3TO	R9P603O3D1
	Package	R9P621O300 {R9P603O300 + R9P015 (FCC ID: NHS-R9P014)}	R9P621O3TO {R9P603O3TO + R9P015 (FCC ID: NHS-R9P014)}	R9P621O3D1 {R9P603O3D1 + R9P015 (FCC ID: NHS-R9P014)}
	Package	R9P622O300 {R9P603O300 + R9P015 (FCC ID: NHS-R9P014) + R9P130NI00 (FCC ID: NHS-R9P125)}	R9P622O3TO {R9P603O3TO + R9P015 (FCC ID: NHS-R9P014) + R9P130NI00 (FCC ID: NHS-R9P125)}	R9P622O3D1 {R9P603O3D1 + R9P015 (FCC ID: NHS-R9P014) + R9P130NI00 (FCC ID: NHS-R9P125)}
Secondary		n/a	1 Set (Phone/Data Line Protection)	1 Pair (Coax (Protection))

Remark: 1. The FCC ID Number is NHS-R9P014 have been tested in other report of EM-F990986.

2. The FCC ID Number is NHS-R9P125 have been tested in other report of EM-F990987.

The M/N R9P602O300 is representative selected to test in this report.

Applicant : Powertech Industrial Co Ltd
10F, No. 407, Chung Shan Rd., Sec 2
Chung Ho City, Taipei Hsien, 235 Taiwan

Fundamental Frequency : 915MHz
 AC Rating : 15A/125V
 Date of Receipt of Sample : Sep. 15, 2010
 Date of Test : Sep. 29 ~ Oct. 29, 2010

1.2. Description of Test Facility

Name of Firm : **AUDIX Technology Corporation
EMC Department**
 No. 53-11, Tin-Fu Tsun, Lin-Kou Hsiang,
 Taipei Hsien, Taiwan.

Test Facility & Location : **No. 2 Shielded Room &
Semi-Anechoic Chamber**
 (C2/AC) No. 53-11, Tin-Fu Tsun, Lin-Kou Hsiang,
 Taipei Hsien, Taiwan.
 Renewal on May 14, 2009
 Federal Communication Commission
 Registration Number: 90993

NVLAP Lab. Code : 200077-0

TAF Accreditation No : 1724

1.3. Measurement Uncertainty

Test Item	Frequency Range	Uncertainty (dB)
Conduction Test	150kHz~30MHz	±1.73dB
Radiation Test (Distance: 3m)	30MHz~300MHz	± 2.91dB
	300MHz~1000MHz	± 2.94dB
	Above 1GHz	± 5.02dB

Remark : Uncertainty = $ku_c(y)$

2. POWERLINE CONDUCTED EMISSION MEASUREMENT

2.1. Test Equipment

The following test equipment were used during the power line conducted measurement: (No. 2 Shielded Room)

Item	Type	Manufacturer	Model No.	Serial No.	Last Cal.	Next Cal.
1.	Test Receiver	R & S	ESCS30	100339	Mar. 10, 10'	Mar. 09, 11'
2.	A.M.N.	R & S	ESH2-Z5	890485/023	Jan. 15, 10'	Jan. 14, 11'
3.	Pulse Limiter	R & S	ESH3-Z2	001	Feb. 08, 10'	Feb. 07, 11'

2.2. Block Diagram of Test Setup

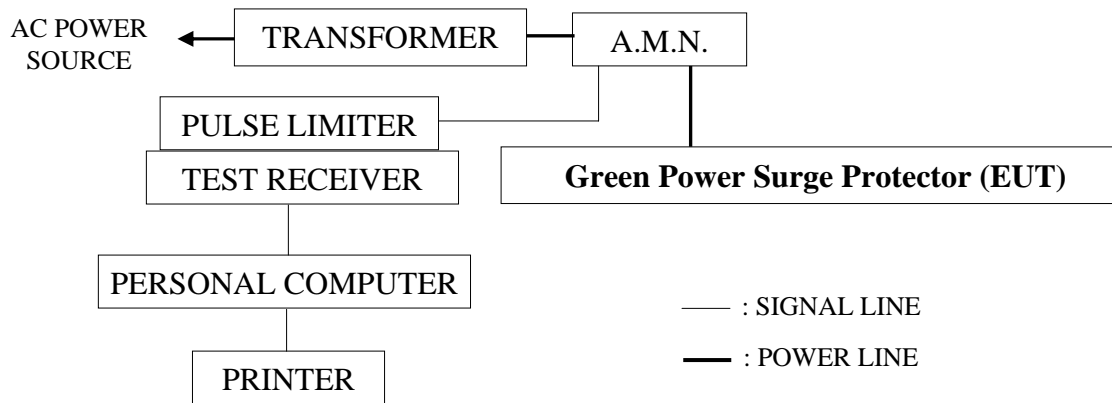

2.3. Powerline Conducted Emission Limit (§15.207)

Frequency	Maximum RF Line Voltage	
	Quasi-Peak Level	Average Level
150kHz ~ 500kHz	66 ~ 56 dB μ V	56 ~ 46 dB μ V
500kHz ~ 5MHz	56 dB μ V	46 dB μ V
5MHz ~ 30MHz	60 dB μ V	50 dB μ V

Remark1.: If the average limit is met when using a Quasi-Peak detector, the EUT shall be deemed to meet both limits and measurement with the average detector is unnecessary.

2.: The lower limit applies at the band edges.

2.4. Operating Condition of EUT

- 2.4.1. Setup the EUT as shown on 2.2.
- 2.4.2. Turn on the power of all equipment.
- 2.4.3. The EUT was on Tranceive function at work during all testing.

2.5. Test Procedure

The EUT was put on table which was above the ground by 80cm and its power cord was connected to power mains through an Artificial Mains Network (A.M.N.). This provided a 50 ohm coupling impedance for the measuring equipment. (Please refer to the block diagram of the test setup and photographs.) Both sides of A.C. line were checked for maximum conducted interference. In order to find the maximum emission, the relative positions simulators of the interface cables should be manipulated according to FCC ANSI C63.4-2003 during conducted measurement.

The bandwidth of the R&S Test Receiver ESCS30 was set at 9kHz.

The frequency range from 150kHz to 30MHz was checked.

All the final readings from Test Receiver were measured with the Quasi-Peak detector and Average detector. (Remark: If the Average limit is met when using a Quasi-Peak detector, the Average detector is unnecessary)

2.6. Powerline Conducted Emission Measurement Results

PASSED.

All emissions not reported below are too low against the prescribed limits.

The EUT was measured during this section testing and all the test results are listed in next pages.

EUT : Green Power Surge Protector M/N : R9P602O300

Test Date : Oct. 01, 2010 Temperature : 24°C Humidity : 54%

Mode	Test Mode	Reference Test Data	
		Neutral	Line
1.	Transceive	# 2	# 1



AUDIX TECHNOLOGY Corp. EMC Laboratory
 No.53-11, Tin-fu Tsun, Lin-kou Hsiang, Taipei
 County, Taiwan R.O.C. Post Code:24443
 Tel:02-26092133 Fax:02-26099303
 Email:ttemc@ttemc.com.tw

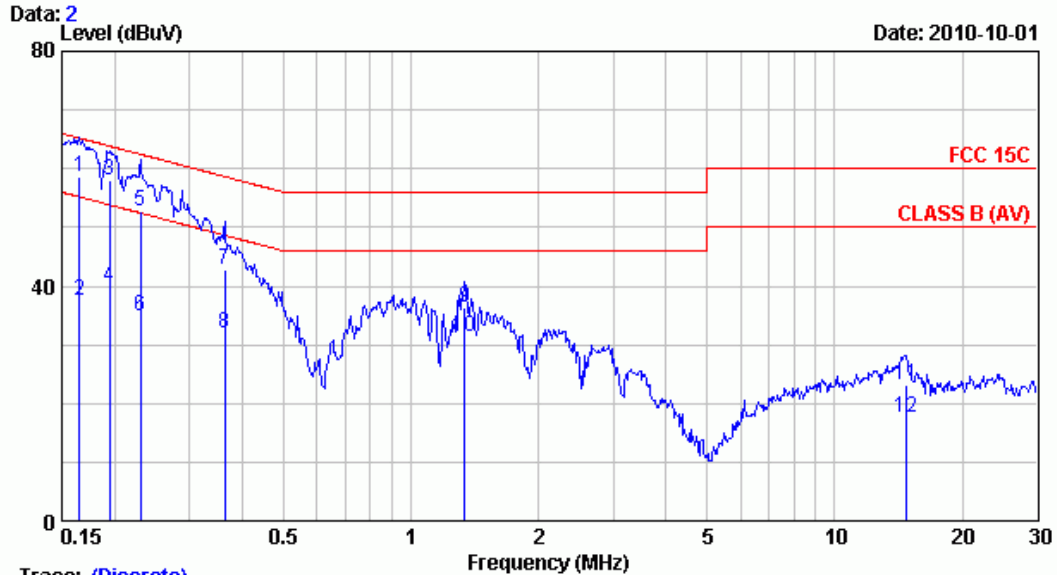

Trace: (Discrete)

Site	: No.2 Shielded room	Data	: 2
Condition	: ESH3-Z5	Phase	: NEUTRAL
Limit	: FCC 15C		
Env. / Ins.	: 24*C,54% / ESCS 30 (339)	Engineer:	Charles_Yuan
EUT	: R9P6020300		
Power Rating	: 120Vac/60Hz		
Test Mode	: operating		

	AMN	Cable	Emission		Limits	Margin	Remark
Freq. (MHz)	Factor (dB)	Loss (dB)	Reading (dBuV)	Level (dBuV)	(dBuV)	(dB)	
1	0.165	0.10	58.31	58.65	65.21	6.55	QP
2	0.165	0.10	37.29	37.63	55.21	17.57	AVERAGE
3	0.194	0.10	57.74	58.10	63.85	5.75	QP
4	0.194	0.10	39.44	39.80	53.85	14.05	AVERAGE
5	0.230	0.10	52.28	52.65	62.44	9.79	QP
6	0.230	0.10	34.63	35.00	52.44	17.44	AVERAGE
7	0.363	0.10	42.36	42.77	58.65	15.88	QP
8	0.363	0.10	31.60	32.01	48.65	16.64	AVERAGE
9	1.340	0.10	35.92	36.42	56.00	19.58	QP
10	1.340	0.10	30.96	31.46	46.00	14.54	AVERAGE
11	14.750	0.59	21.90	23.19	60.00	36.81	QP
12	14.750	0.70	16.28	17.57	50.00	32.43	AVERAGE

Remarks: 1.Emission Level= AMN Factor + Cable Loss + Reading.
 2.If the average limit is met when using a quasi-peak detector ,the EUT shall be deemed to meet both limits and measurement with average detector is unnecessary.



AUDIX TECHNOLOGY Corp. EMC Laboratory
 No.53-11, Tin-fu Tsun, Lin-kou Hsiang, Taipei
 County, Taiwan R.O.C. Post Code:24443
 Tel:02-26092133 Fax:02-26099303
 Email:ttemc@ttemc.com.tw

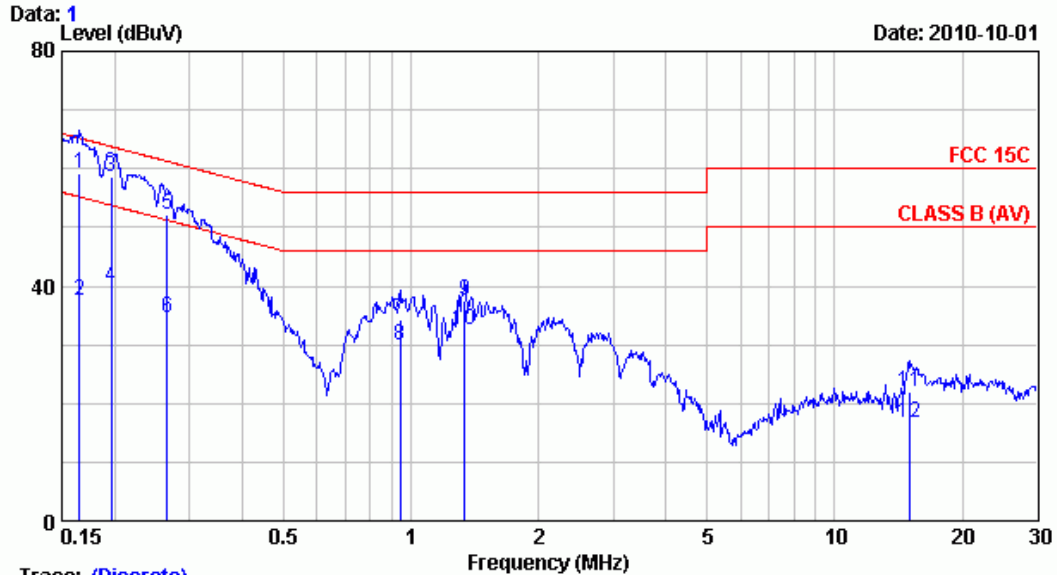

Trace: (Discrete)

Site	: No.2 Shielded room	Data	: 1
Condition	: ESH3-Z5	Phase	: LINE
Limit	: FCC 15C		
Env. / Ins.	: 24*C,54% / ESCS 30 (339)	Engineer:	: Charles_Yuan
EUT	: R9P6020300		
Power Rating	: 120Vac/60Hz		
Test Mode	: operating		

	AMN	Cable	Emission		Limits	Margin	Remark	
Freq. (MHz)	Factor (dB)	Loss (dB)	Reading (dBμV)	Level (dBμV)	(dBμV)	(dB)		
1	0.165	0.10	0.24	58.82	59.16	65.21	6.04	QP
2	0.165	0.10	0.24	37.29	37.63	55.21	17.57	AVERAGE
3	0.197	0.10	0.26	58.34	58.70	63.76	5.06	QP
4	0.197	0.10	0.26	39.44	39.80	53.76	13.96	AVERAGE
5	0.266	0.10	0.28	51.76	52.14	61.26	9.11	QP
6	0.266	0.10	0.28	34.32	34.70	51.26	16.55	AVERAGE
7	0.943	0.10	0.39	33.85	34.34	56.00	21.66	QP
8	0.943	0.10	0.39	29.41	29.90	46.00	16.10	AVERAGE
9	1.341	0.14	0.40	36.87	37.41	56.00	18.59	QP
10	1.341	0.14	0.40	32.08	32.62	46.00	13.38	AVERAGE
11	15.000	0.70	0.70	20.61	22.01	60.00	37.99	QP
12	15.000	0.70	0.70	15.24	16.64	50.00	33.36	AVERAGE

Remarks: 1.Emission Level= AMN Factor + Cable Loss + Reading.
 2.If the average limit is met when using a quasi-peak detector ,the EUT shall be deemed to meet both limits and measurement with average detector is unnecessary.

3. RADIATED EMISSION MEASUREMENT

3.1. Test Equipment

The following test equipment was used during the radiated emission measurement:

3.1.1. For Frequency Range 30MHz~1000MHz (Semi-Anechoic Chamber)

Item	Type	Manufacturer	Model No.	Serial No.	Last Cal.	Next Cal.
1.	Test Receiver	R & S	ESCS30	100339	Mar. 10, 10'	Mar. 09, 11'
2.	Spectrum Analyzer	HP	8564EC	3946A00249	Oct. 27, 10'	Oct. 26, 11'
3.	Pre-Amplifier	HP	8447D	2944A06305	Feb. 03, 10'	Feb. 02, 11'
4.	Biconical Antenna	CHASE	VBA6106A	1264	Mar. 13, 10'	Mar. 12, 11'
5.	Log Periodic Antenna	Schwarzbeck	UHALP 9108-A	0810	Mar. 13, 10'	Mar. 12, 11'

3.1.2. For Frequency Range Above 1GHz (Semi-Anechoic Chamber)

Item	Type	Manufacturer	Model No.	Serial No.	Last Cal.	Next Cal.
1.	Spectrum Analyzer	HP	8564EC	3946A00249	Oct. 27, 10'	Oct. 26, 11'
2.	Amplifier	HP	8449B	3008A00529	Dec. 15, 09'	Dec. 14, 10'
3.	Horn Antenna	EMCO	3115	9112-3775	May 10, 10'	May 09, 11'

3.2. Test Setup

3.2.1. Block Diagram of connection between EUT and simulators



3.2.2. Semi-Anechoic Chamber (3m) Setup Diagram for 30-1000MHz

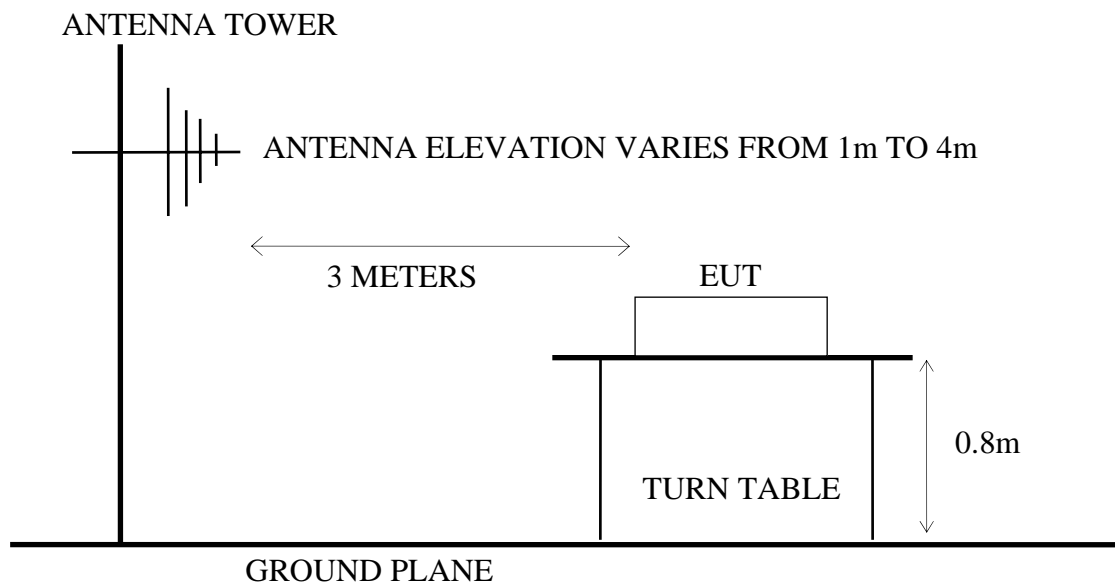

3.2.3. Semi-Anechoic Chamber (3m) Setup Diagram for above 1GHz

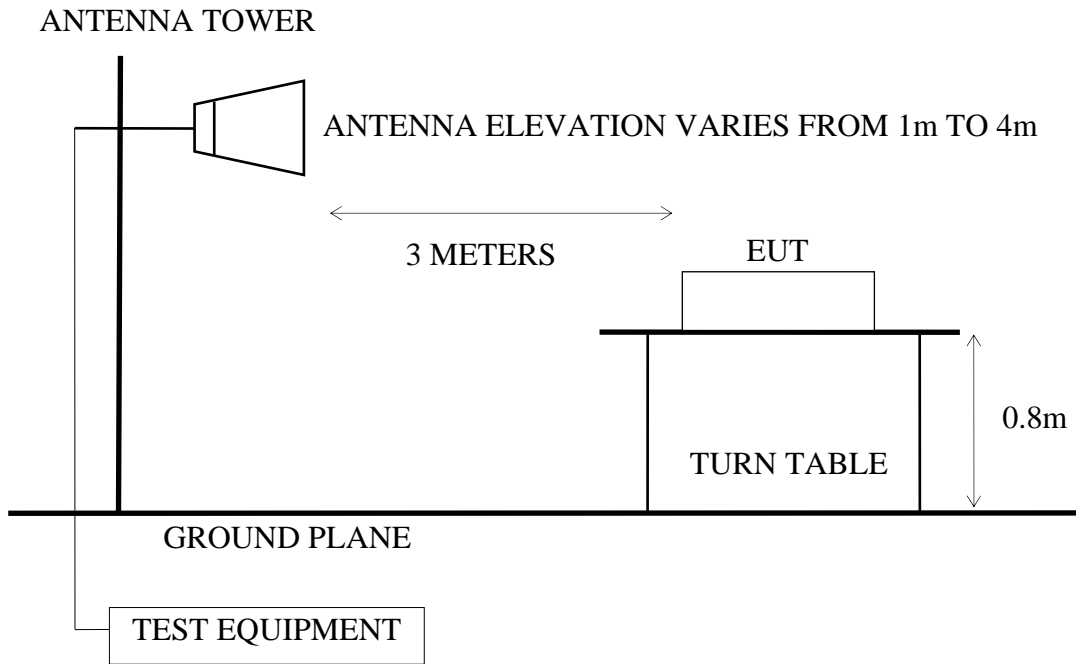

3.3. Radiated Emission Limits (§15.209)

FREQUENCY MHz	DISTANCE Meters	FIELD STRENGTHS LIMITS	
		$\mu\text{V/m}$	$\text{dB}\mu\text{V/m}$
30 ~ 88	3	100	40.0
88 ~ 216	3	150	43.5
216 ~ 960	3	200	46.0
Above 960	3	500	54.0
Above 1000	3	74.0 $\text{dB}\mu\text{V/m}$ (Peak) 54.0 $\text{dB}\mu\text{V/m}$ (Average)	

- Remark :
- (1) Emission level ($\text{dB}\mu\text{V/m}$) = 20 log Emission level ($\mu\text{V/m}$)
 - (2) The tighter limit applies at the edge between two frequency bands.
 - (3) Distance refers to the distance in meters between the measuring instrument antenna and the closed point of any part of the device or system.
 - (4) The limits in this table are based on CFR 47 Part 15.205(a)(b) and Part 15.209 (a).
 - (5) The over 1GHz limit, FCC limit is used based on CFR 47 Part 15.35 (b) and Part 15.205(b) & Part 15.209(e) and Part 15.207(c).

3.4. Fundamental Frequency Limits (§15.249)

FUNDAMENTAL FREQUENCY MHZ	QP
902-928	94 $\text{dB}\mu\text{V/m}$

3.5. Operating Condition of EUT

- 3.5.1. Setup the EUT as shown on 3.2.
- 3.5.2. Turn on the power of all equipment.
- 3.5.3. The EUT was on Tranceive function at work during all testing.

3.6. Test Procedure

The EUT and its simulators were placed on a turn table which was 0.8 meter above the ground. The turn table rotated 360 degrees to determine the position of the maximum emission level. EUT was set to 3 meters away from the receiving antenna which was mounted on an antenna tower. The antenna moved up and down between 1 to 4 meters to find out the maximum emission level. Broadband antenna such as calibrated biconical and log-periodical antenna or horn antenna were used as a receiving antenna. Both horizontal and vertical polarization of the antenna were set on measurement. In order to find the maximum emission, all of the interface cables were manipulated according to FCC ANSI C63.4-2003 regulation.

The bandwidth of the R&S Test Receiver ESCS30 was set at 120kHz. (For 30MHz to 1000MHz)

The resolution bandwidth and video bandwidth of test spectrum analyzer is 1MHz for peak detection (PK) at frequency above 1GHz.

The resolution bandwidth of test spectrum analyzer is 1MHz and the video bandwidth is 10Hz for average detection (AV) at frequency above 1GHz.

The frequency range from 30MHz to 10GHz (Up to 10th harmonics from fundamental frequency) was checked.

3.7. Radiated Emission Measurement Test Results

PASSED.

(All emissions not reported below are too low against the prescribed limits.)

EUT : Green Power Surge Protector M/N : R9P602O300

Test Date : Sep. 29, 2010 Temperature : 26°C Humidity : 53%

Test Date : Oct. 29, 2010 Temperature : 26°C Humidity : 53%

For Frequency Range 30MHz~1000MHz:

The EUT was measured during this section testing and all the test results are listed in section 3.7.1.

Mode	Test Mode	Reference Test Data	
		Horizontal	Vertical
1.	Transceive	# 7	# 8

* Above all final readings were measured with Quasi-Peak detector.

For Out of Band:

The EUT was measured during this section testing and all the test results are listed in section 3.7.2.

Mode	Test Mode	Reference Test Data	
		Horizontal	Vertical
1.	Transceive	# 1	# 2

For Frequency above 1GHz:

The EUT with the following test modes was measured within semi-anechoic chamber. All the graphical results are listed in section 3.7.3.

NO.	Test Mode	Test Frequency Range
1.	Transceive	1000-2680MHz
2.		2680-5500MHz
3.		5500-10000MHz

* Above emissions level is too low to be measured, therefore, the reading values not reported.

For Fundamental Frequency:

The EUT was measured during this section testing and all the test results are listed in section 3.7.4.

3.7.1. Frequency Range 30-1000MHz



AUDIX TECHNOLOGY Corp. EMC Laboratory
 No.53-11, Tin-fu Tsun, Lin-kou Hsiang, Taipei
 County, Taiwan R.O.C. Post Code:24443
 Tel:+886-2-26092133 Fax:+886-2-26099303
 Email:ttemc@ttemc.com.tw

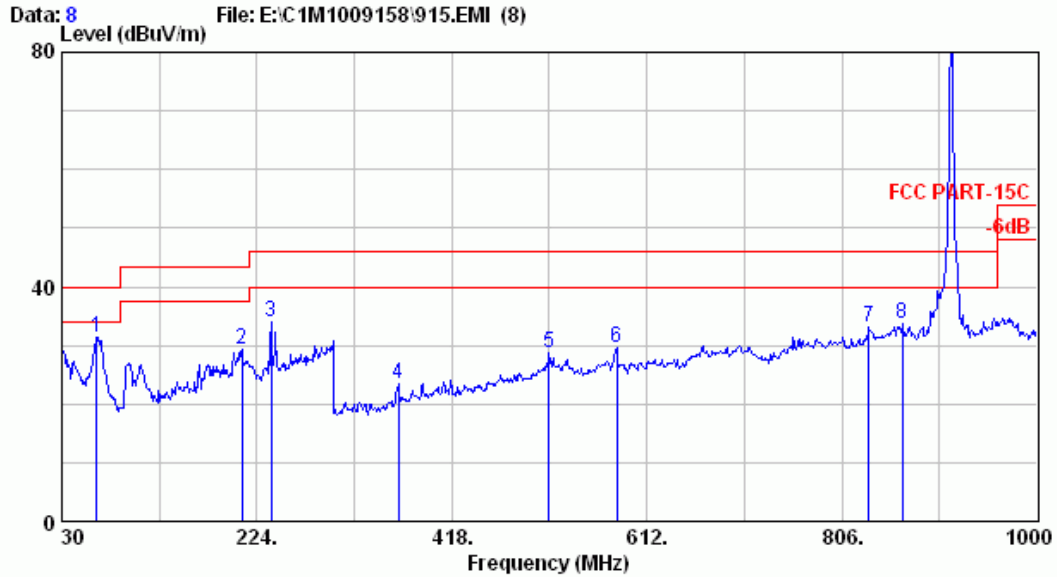

Site no. : A/C Chamber Data no. : 8
 Dis. / Ant. : 3m VBA6106A/UHALP9108A Ant. pol. : VERTICAL
 Limit : FCC PART-15C
 Env. / Ins. : 8564EC 26°C /53% Engineer : Jarwei Wang
 EUT : Green Power Surge Protector
 Power Rating : 120Vac/60Hz M/N:R9P602O300
 Test Mode : operating

	Ant. Factor	Cable Loss	Reading	Emission Level	Limits	Margin	Remark
Freq. (MHz)	(dB/m)	(dB)	(dBuV)	(dBuV/m)	(dBuV/m)	(dB)	
1	11.81	1.70	17.86	31.37	40.00	8.63	
2	21.81	3.16	4.27	29.24	43.50	14.26	
3	22.94	3.40	7.80	34.14	46.00	11.86	
4	16.52	4.50	2.47	23.49	46.00	22.51	
5	19.97	6.80	1.82	28.59	46.00	17.41	
6	20.91	6.30	2.43	29.64	46.00	16.36	
7	24.88	7.10	1.17	33.15	46.00	12.85	
8	25.97	7.20	0.45	33.62	46.00	12.38	

Remarks: 1. Emission Level= Antenna Factor + Cable Loss + Reading.
 2. The emission levels that are 20dB below the official limit are not reported.
 3. All readings are Quasi-Peak values.



AUDIX TECHNOLOGY Corp. EMC Laboratory
 No.53-11, Tin-fu Tsun, Lin-kou Hsiang, Taipei
 County, Taiwan R.O.C. Post Code:24443
 Tel:+886-2-26092133 Fax:+886-2-26099303
 Email:ttemc@ttemc.com.tw

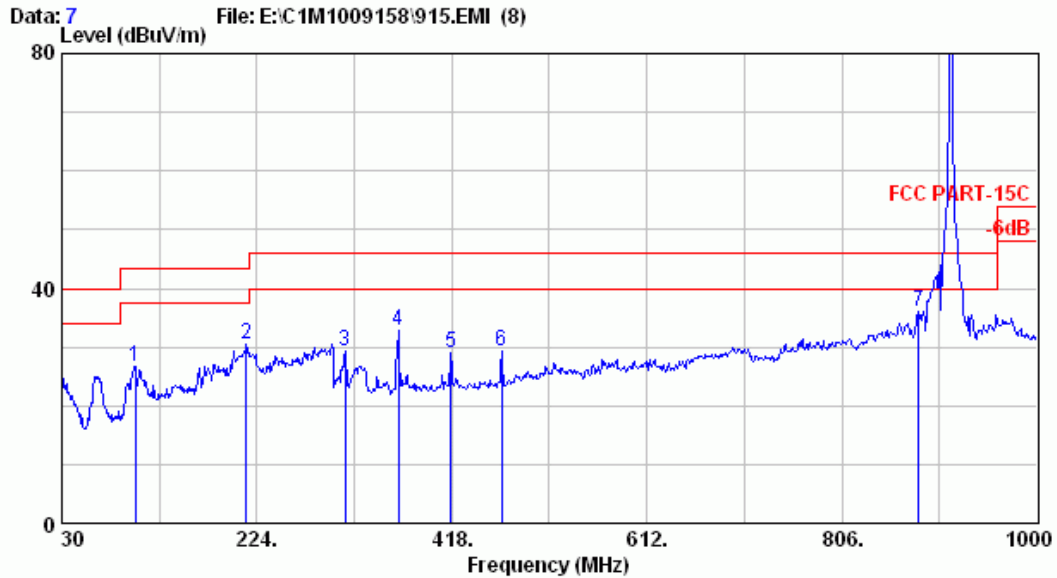

Site no. : A/C Chamber Data no. : 7
 Dis. / Ant. : 3m VBA6106A/UHALP9108A Ant. pol. : HORIZONTAL
 Limit : FCC PART-15C
 Env. / Ins. : 8564EC 26°C /53% Engineer : Jarwei Wang
 EUT : Green Power Surge Protector
 Power Rating : 120Vac/60Hz M/N:R9P602O300
 Test Mode : operating

	Freq. (MHz)	Ant. Factor (dB/m)	Cable Loss (dB)	Reading (dBµV)	Emission Level (dBµV/m)	Limits (dBµV/m)	Margin (dB)	Remark
1	102.750	17.40	2.10	7.17	26.67	43.50	16.83	
2	213.330	21.76	3.10	5.53	30.39	43.50	13.11	
3	312.270	14.76	4.00	10.55	29.31	46.00	16.69	
4	364.650	16.52	4.50	11.90	32.92	46.00	13.08	
5	417.030	16.95	5.08	7.05	29.07	46.00	16.93	
6	467.470	18.21	5.80	5.28	29.29	46.00	16.71	
7	882.630	25.28	7.30	3.60	36.18	46.00	9.82	

Remarks: 1. Emission Level= Antenna Factor + Cable Loss + Reading.
 2. The emission levels that are 20dB below the official limit are not reported.
 3. All readings are Quasi-Peak values.

3.7.2. Out of Band



AUDIX TECHNOLOGY Corp. EMC Laboratory
 No.53-11, Tin-fu Tsun, Lin-kou Hsiang, Taipei
 County, Taiwan R.O.C. Post Code:24443
 Tel:+886-2-26092133 Fax:+886-2-26099303
 Email:ttemc@ttemc.com.tw

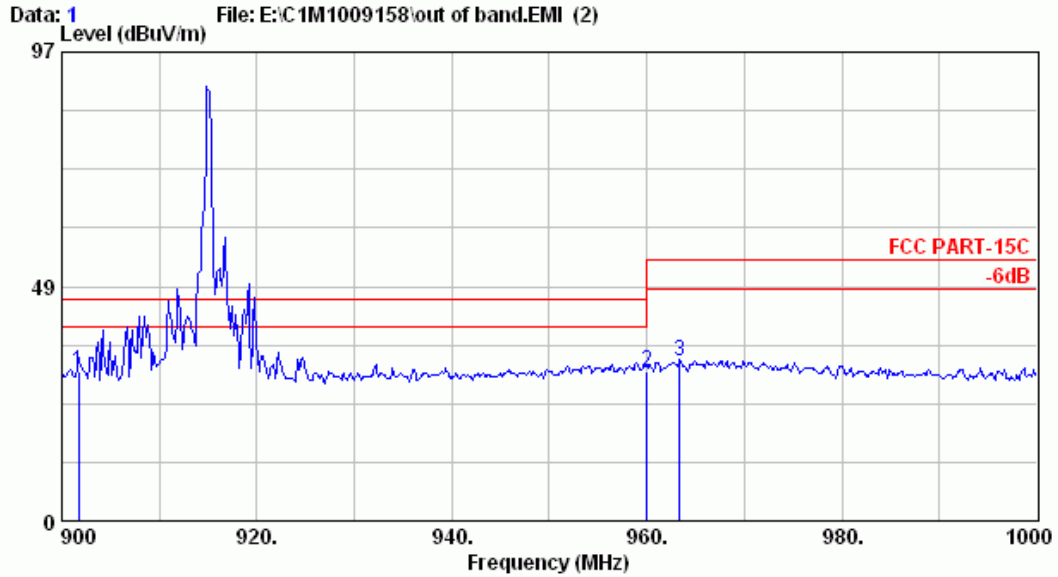

Site no. : A/C Chamber Data no. : 1
 Dis. / Ant. : 3m UHALP9108A(0139)2006 Ant. pol. : HORIZONTAL
 Limit : FCC PART-15C
 Env. / Ins. : 8564EC 26°C /53% Engineer : Jarwei Wang
 EUT : Green Power Surge Protector
 Power Rating : 120Vac/60Hz M/N:R9P602O300
 Test Mode : operating

	Freq. (MHz)	Ant. Factor (dB/m)	Cable Loss (dB)	Reading (dBuV)	Emission Level (dBuV/m)	Limits (dBuV/m)	Margin (dB)	Remark
1	901.700	24.92	7.40	-1.47	30.85	46.00	15.15	
2	960.000	26.42	7.60	-3.05	30.97	46.00	15.03	
3	963.400	26.71	7.60	-1.33	32.98	54.00	21.02	

Remarks: 1. Emission Level= Antenna Factor + Cable Loss + Reading.
 2. The emission levels that are 20dB below the official limit are not reported.



AUDIX TECHNOLOGY Corp. EMC Laboratory
 No.53-11, Tin-fu Tsun, Lin-kou Hsiang, Taipei
 County, Taiwan R.O.C. Post Code:24443
 Tel:+886-2-26092133 Fax:+886-2-26099303
 Email:ttemc@ttemc.com.tw

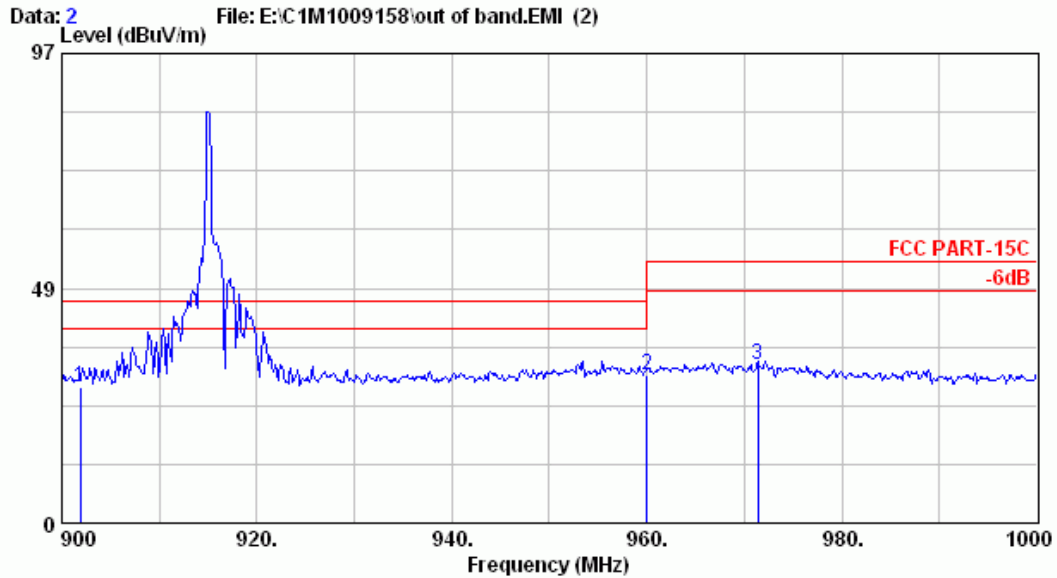

Site no. : A/C Chamber Data no. : 2
 Dis. / Ant. : 3m UHALP9108A(0139)2006 Ant. pol. : VERTICAL
 Limit : FCC PART-15C
 Env. / Ins. : 8564EC 26°C /53% Engineer : Jarwei Wang
 EUT : Green Power Surge Protector
 Power Rating : 120Vac/60Hz M/N:R9P6020300
 Test Mode : operating

	Freq. (MHz)	Ant. Factor (dB/m)	Cable Loss (dB)	Reading (dBµV)	Emission Level (dBµV/m)	Limits (dBµV/m)	Margin (dB)	Remark
1	901.900	24.92	7.40	-4.16	28.16	46.00	17.84	
2	960.000	26.42	7.60	-3.37	30.65	46.00	15.35	
3	971.400	26.79	7.70	-1.71	32.78	54.00	21.22	

Remarks: 1. Emission Level= Antenna Factor + Cable Loss + Reading.
 2. The emission levels that are 20dB below the official limit are not reported.

3.7.3. Frequency Range 1000-10000MHz



AUDIX TECHNOLOGY Corp. EMC Laboratory
 No.53-11, Tin-fu Tsun, Lin-kou Hsiang, Taipei
 County, Taiwan R.O.C. Post Code:24443
 Tel:+886-2-26092133 Fax:+886-2-26099303
 Email:ttemc@ttemc.com.tw

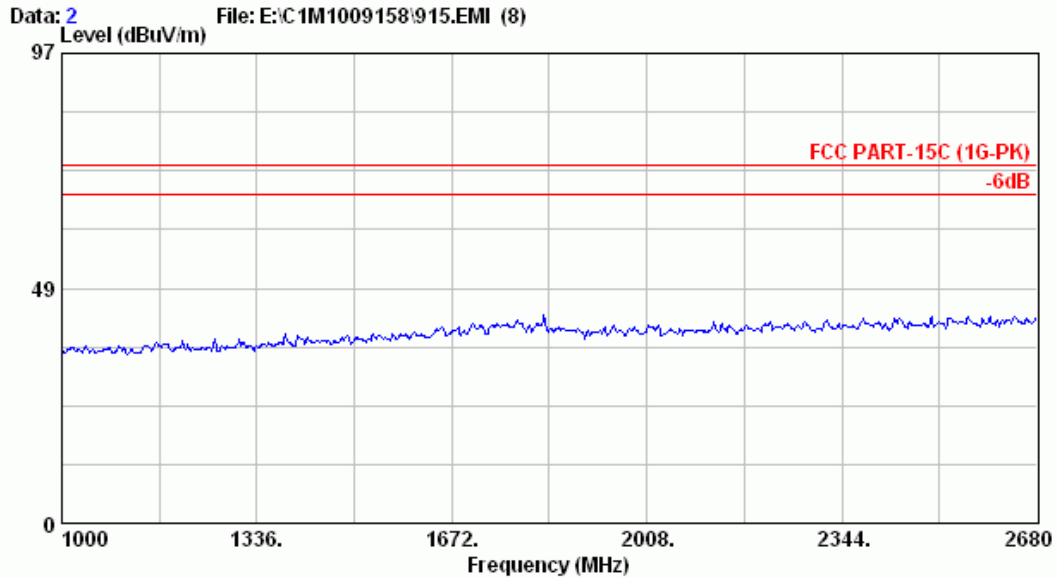

Site no. : A/C Chamber Data no. : 2
 Dis. / Ant. : 3m 3115(4927) Ant. pol. : HORIZONTAL
 Limit : FCC PART-15C (1G-PK)
 Env. / Ins. : 8564EC 26°C /53% Engineer : Jarwei Wang
 EUT : Green Power Surge Protector
 Power Rating : 120Vac/60Hz M/N:R9P6020300
 Test Mode : operating

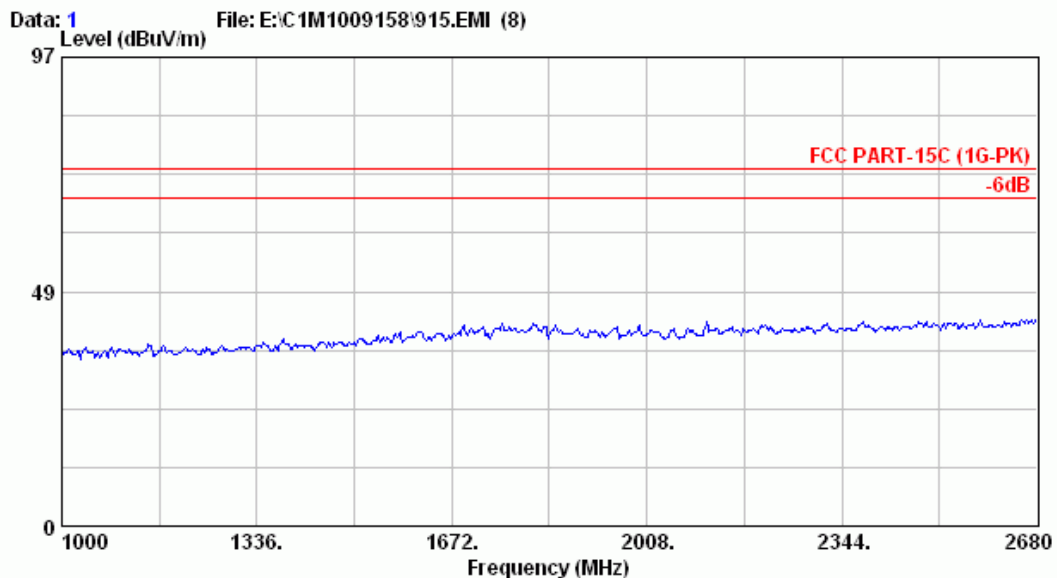

Site no. : A/C Chamber Data no. : 1
 Dis. / Ant. : 3m 3115(4927) Ant. pol. : VERTICAL
 Limit : FCC PART-15C (1G-PK)
 Env. / Ins. : 8564EC 26°C /53% Engineer : Jarwei Wang
 EUT : Green Power Surge Protector
 Power Rating : 120Vac/60Hz M/N:R9P6020300
 Test Mode : operating



AUDIX TECHNOLOGY Corp. EMC Laboratory
 No.53-11, Tin-fu Tsun, Lin-kou Hsiang, Taipei
 County, Taiwan R.O.C. Post Code:24443
 Tel:+886-2-26092133 Fax:+886-2-26099303
 Email:ttemc@ttemc.com.tw

Data: 3 File: E:\C1M1009158\915.EMI (8)

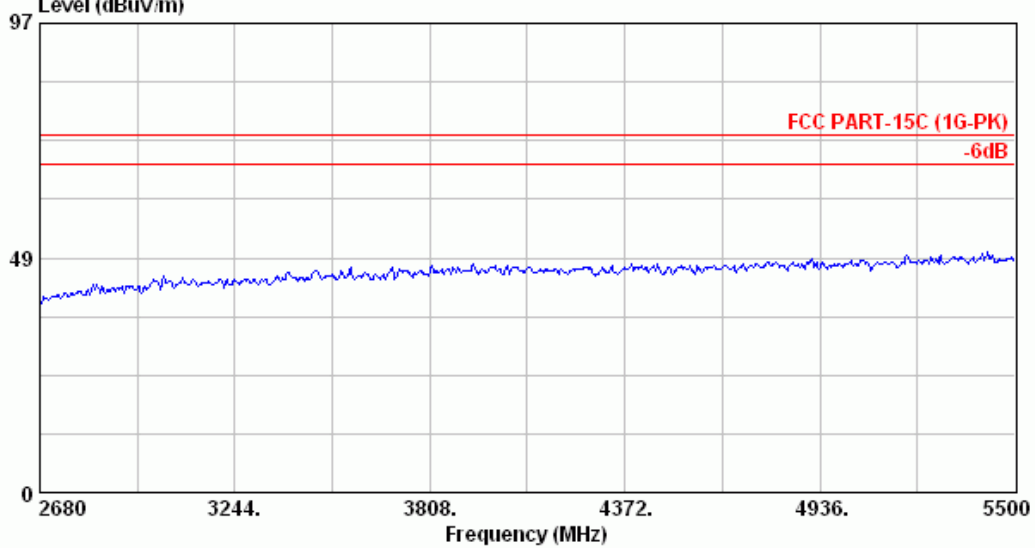

Site no. : A/C Chamber Data no. : 3
 Dis. / Ant. : 3m 3115(4927) Ant. pol. : HORIZONTAL
 Limit : FCC PART-15C (1G-PK)
 Env. / Ins. : 8564EC 26°C /53% Engineer : Jarwei Wang
 EUT : Green Power Surge Protector
 Power Rating : 120Vac/60Hz M/N:R9P602O300
 Test Mode : operating

Data: 4 File: E:\C1M1009158\915.EMI (8)

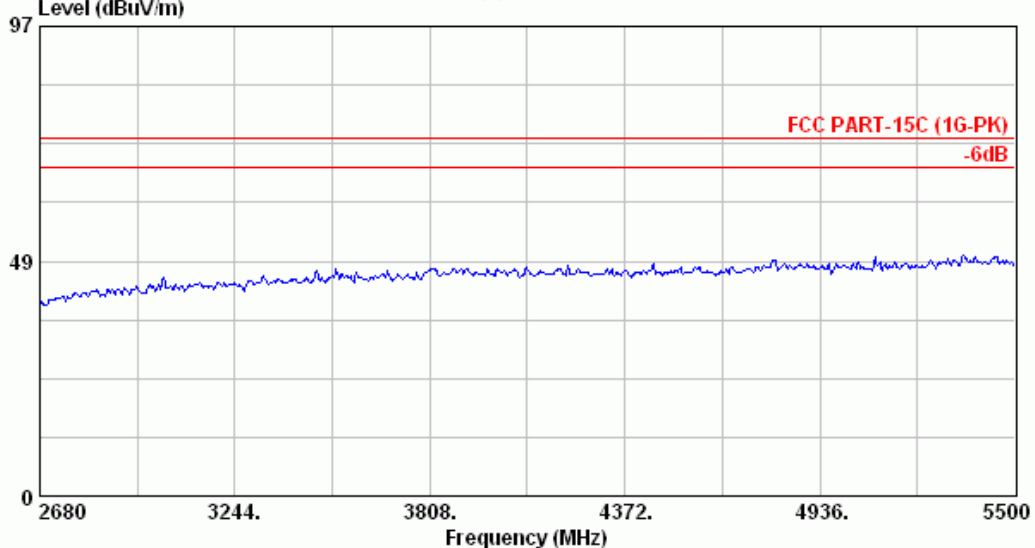

Site no. : A/C Chamber Data no. : 4
 Dis. / Ant. : 3m 3115(4927) Ant. pol. : VERTICAL
 Limit : FCC PART-15C (1G-PK)
 Env. / Ins. : 8564EC 26°C /53% Engineer : Jarwei Wang
 EUT : Green Power Surge Protector
 Power Rating : 120Vac/60Hz M/N:R9P602O300
 Test Mode : operating



AUDIX TECHNOLOGY Corp. EMC Laboratory
 No.53-11, Tin-fu Tsun, Lin-kou Hsiang, Taipei
 County, Taiwan R.O.C. Post Code:24443
 Tel:+886-2-26092133 Fax:+886-2-26099303
 Email:ttemc@ttemc.com.tw

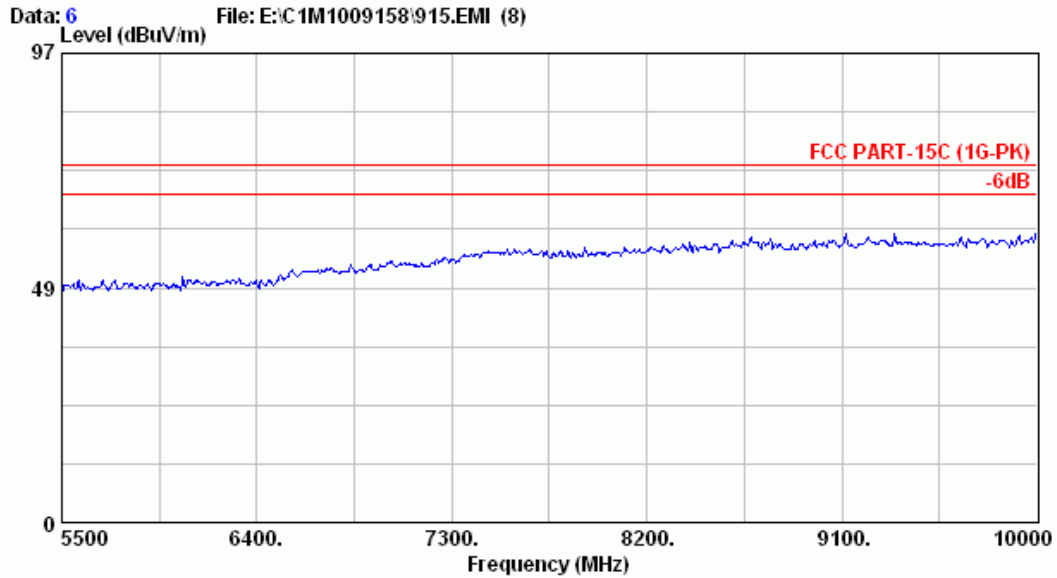

Site no.	: A/C Chamber	Data no.	: 6
Dis. / Ant.	: 3m 3115(4927)	Ant. pol.	: HORIZONTAL
Limit	: FCC PART-15C (1G-PK)		
Env. / Ins.	: 8564EC 26°C /53%	Engineer	: Jarwei Wang
EUT	: Green Power Surge Protector		
Power Rating	: 120Vac/60Hz M/N:R9P602O300		
Test Mode	: operating		

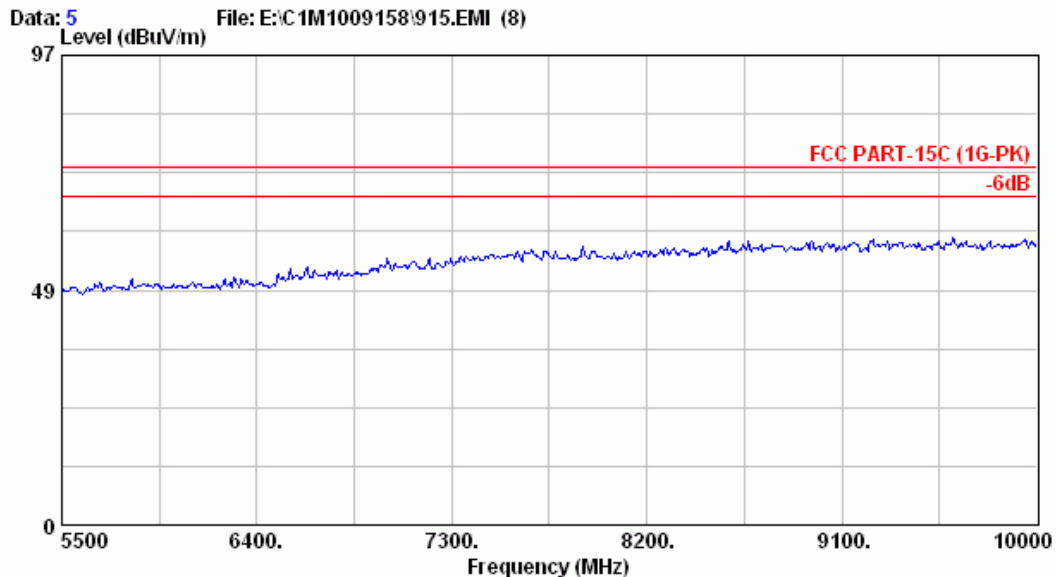

Site no.	: A/C Chamber	Data no.	: 5
Dis. / Ant.	: 3m 3115(4927)	Ant. pol.	: VERTICAL
Limit	: FCC PART-15C (1G-PK)		
Env. / Ins.	: 8564EC 26°C /53%	Engineer	: Jarwei Wang
EUT	: Green Power Surge Protector		
Power Rating	: 120Vac/60Hz M/N:R9P602O300		
Test Mode	: operating		

3.7.4. Fundamental Frequency



AUDIX TECHNOLOGY Corp. EMC Laboratory
 No.53-11, Tin-fu Tsun, Lin-kou Hsiang, Taipei
 County, Taiwan R.O.C. Post Code:24443
 Tel:+886-2-26092133 Fax:+886-2-26099303
 Email:ttemc@ttemc.com.tw

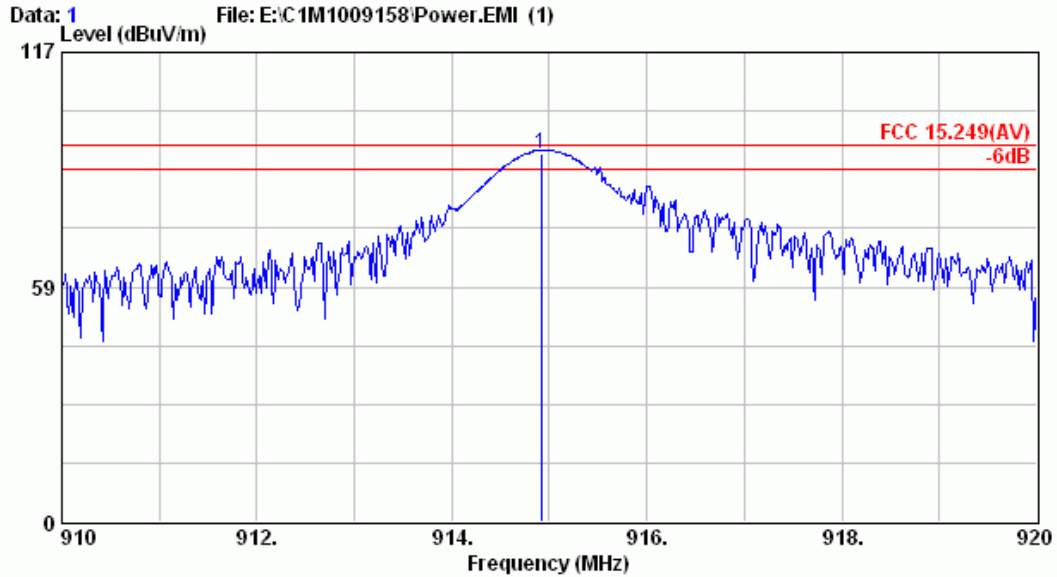

Site no. : A/C Chamber Data no. : 1
 Dis. / Ant. : 3m UHALP9108A(0139)2006 Ant. pol. : HORIZONTAL
 Limit : FCC 15.249(AV)
 Env. / Ins. : 8564EC 26°C /53% Engineer : Jarwei Wang
 EUT : Green Power Surge Protector
 Power Rating : 120Vac/60Hz M/N:R9P602O300
 Test Mode : operating

	Ant. Factor	Cable Loss	Emission Reading	Emission Level	Limits	Margin	Remark
Freq. (MHz)	(dB/m)	(dB)	(dBuV)	(dBuV/m)	(dBuV/m)	(dB)	
1 914.920	24.92	7.40	59.54	91.86	94.00	2.14	QP

Remarks: 1. Emission Level= Antenna Factor + Cable Loss + Reading.
 2. The emission levels that are 20dB below the official limit are not reported.
 3. Because fundament frequency peak values have bee lower than the average limit, so most don't measure the average value.

4. DEVIATION TO TEST SPECIFICATIONS

【NONE】