

Prüfbericht-Nr.: <i>Test Report No.:</i>	10042740 001	Auftrags-Nr.: <i>Order No.:</i>	114026471	Seite 1 von 24 <i>Page 1 of 24</i>
Kunden-Referenz-Nr.: <i>Client Reference No.:</i>	N/A	Auftragsdatum: <i>Order date:</i>	September 1, 2014	
Auftraggeber: <i>Client:</i>	Powertech, 10F, No. 407, Chung Shan Rd., Sec 2 Chung Ho City, Taipei Hsien, 235, Taiwan			
Prüfgegenstand: <i>Test item:</i>	Mobile Accessory - Breathalyzer			
Bezeichnung / Typ-Nr.: <i>Identification / Type No.:</i>	A02A			
Auftrags-Inhalt: <i>Order content:</i>	FCC/IC Test report			
Prüfgrundlage: <i>Test specification:</i>	FCC 47CFR Part 15: Subpart C Section 15.247 RSS-210 (12-2010) A8			
Wareneingangsdatum: <i>Date of receipt:</i>	9/3/2014			
Prüfmuster-Nr.: <i>Test sample No.:</i>	A000103946-003			
Prüfzeitraum: <i>Testing period:</i>	23-Sep-2014 - 24-Sep-2014			
Ort der Prüfung: <i>Place of testing:</i>	EMC/RF Laboratory Taipei			
Prüflaboratorium: <i>Testing laboratory:</i>	TUV Rheinland Taiwan Ltd.			
Prüfergebnis*: <i>Test result*:</i>	Pass			
geprüft von / tested by:		kontrolliert von / reviewed by:		
2014-12-11  Arvin Ho / Department Manager		2014-12-11  Rene Charton / Senior Project Manager		
<i>Datum</i>	<i>Name / Stellung</i>	<i>Unterschrift</i>	<i>Datum</i>	<i>Name / Stellung</i>
<i>Date</i>	<i>Name / Position</i>	<i>Signature</i>	<i>Date</i>	<i>Name / Position</i>
Sonstiges / Other:				
Zustand des Prüfgegenstandes bei Anlieferung: <i>Condition of the test item at delivery:</i>		Prüfmuster vollständig und unbeschädigt <i>Test item complete and undamaged</i>		
* Legende: 1 = sehr gut 2 = gut 3 = befriedigend 4 = ausreichend 5 = mangelhaft P(ass) = entspricht o.g. Prüfgrundlage(n) F(ail) = entspricht nicht o.g. Prüfgrundlage(n) N/A = nicht anwendbar N/T = nicht getestet				
Legend: 1 = very good 2 = good 3 = satisfactory 4 = sufficient 5 = poor P(ass) = passed a.m. test specification(s) F(ail) = failed a.m. test specification(s) N/A = not applicable N/T = not tested				
Dieser Prüfbericht bezieht sich nur auf das o.g. Prüfmuster und darf ohne Genehmigung der Prüfstelle nicht auszugsweise vervielfältigt werden. Dieser Bericht berechtigt nicht zur Verwendung eines Prüfzeichens. <i>This test report only relates to the a. m. test sample. Without permission of the test center this test report is not permitted to be duplicated in extracts. This test report does not entitle to carry any test mark.</i>				

v04

Prüfbericht - Nr.: 10042740 001*Test Report No.***Seite 2 von 24***Page 2 of 24*

TEST SUMMARY

5.1.1 ANTENNA REQUIREMENT

RESULT: Passed

5.1.2 PEAK OUTPUT POWER

RESULT: Passed

5.1.3 6dB BANDWIDTH

RESULT: Passed

5.1.4 POWER DENSITY

RESULT: Passed

5.1.5 CONDUCTED SPURIOUS EMISSIONS AND FREQUENCY BAND EDGE MEASURED IN 100KHZ BANDWIDTH

RESULT: Passed

5.1.6 SPURIOUS EMISSION

RESULT: Passed

6.1.1 ELECTROMAGNETIC FIELDS

RESULT: Passed

Contents

1.	GENERAL REMARKS	5
1.1	COMPLEMENTARY MATERIALS.....	5
2.	TEST SITES	6
2.1	TEST FACILITIES	6
2.2	LIST OF TEST AND MEASUREMENT INSTRUMENTS.....	7
2.3	TRACEABILITY	8
2.4	CALIBRATION	8
2.5	MEASUREMENT UNCERTAINTY	8
3.	GENERAL PRODUCT INFORMATION.....	9
3.1	PRODUCT FUNCTION AND INTENDED USE	9
3.2	SYSTEM DETAILS AND RATINGS.....	9
3.3	INDEPENDENT OPERATION MODES.....	10
3.4	NOISE GENERATING AND NOISE SUPPRESSING PARTS	10
3.5	SUBMITTED DOCUMENTS.....	10
4.	TEST SET-UP AND OPERATION MODES.....	11
4.1	PRINCIPLE OF CONFIGURATION SELECTION	11
4.2	TEST OPERATION AND TEST SOFTWARE.....	11
4.3	SPECIAL ACCESSORIES AND AUXILIARY EQUIPMENT	11
4.4	COUNTERMEASURES TO ACHIEVE EMC COMPLIANCE.....	12
4.5	TEST SETUP DIAGRAM	12
5.	TEST RESULTS	14
5.1	TRANSMITTER REQUIREMENT & TEST SUITES.....	14
<i>5.1.1</i>	<i>Antenna Requirement</i>	<i>14</i>
<i>5.1.2</i>	<i>Peak Output Power</i>	<i>15</i>
<i>5.1.3</i>	<i>6dB Bandwidth</i>	<i>16</i>
<i>5.1.4</i>	<i>Power Density</i>	<i>17</i>
<i>5.1.5</i>	<i>Conducted spurious emissions and Frequency Band Edge measured in 100kHz Bandwidth.....</i>	<i>18</i>
<i>5.1.6</i>	<i>Spurious Emission</i>	<i>19</i>
6.	SAFETY HUMAN EXPOSURE	20
6.1	RADIO FREQUENCY EXPOSURE COMPLIANCE	20
<i>6.1.1</i>	<i>Electromagnetic Fields.....</i>	<i>20</i>
7.	PHOTOGRAPHS OF THE TEST SET-UP.....	21

8.	LIST OF TABLES	24
9.	LIST OF PHOTOGRAPHS.....	24

1. General Remarks

1.1 Complementary Materials

All attachments are integral parts of this test report. This applies especially to the following appendix:

Appendix P: Photo Documentation internal view
(File Name: 10042740APPENDIX P)

Appendix D: Test Result of Radiated Emissions
(File Name: 10042740APPENDIX D)

Test Specifications

The following standards were applied.

Table 1: Applied Standard and Test Levels

Radio
FCC CFR47 Part 15: Subpart C Section 15.247 RSS-210 Issue 8, December 2010 RSS-Gen, Issue 4, November 2014 ANSI C63.10:2009, KDB558074 D01 DTS Meas Guidance v02

2. Test Sites

2.1 Test Facilities

TUV Rheinland Taiwan Ltd.

11F. No.758, Sec. 4, Bade Rd., Songshan Dist.
Taipei City 105
Taiwan (R.O.C.)

FCC Registration No.: 365730
IC Canada Registration No.: 9465A-1
TAF Accredited NCC Test Lab. No.:0759
TAF ISO17025 Certification effective periods: 2013-Jul-1st to 2016-Jun-30th



Testing Laboratory
0759

2.2 List of Test and Measurement Instruments

Table 2: List of Test and Measurement Equipment

Kind of Equipment	Manufacturer	Type	S/N	Calibrated until
EMI Test Receiver	R&S	ESR7	101062	30-Aug-15
Bilog Antenna	TESEQ	CBL6111D	29802	4-Jul-15
Spectrum Analyzer	R&S	FSV 40	100921	9-Dec-14
Spectrum Analyzer	Agilent	N9010A	MY53470241	19-Jan-15
Horn Antenna	ETS-Lindgren	3117	138160	10-Jan-15
Horn Antenna (18GHz~40GHz)	COM-POWER	AH840	101031	29-Oct-15
Preamplifier (30MHz - 1GHz)	HP	8447F	2805A03335	22-Aug-15
Preamplifier (18 GHz - 40 GHz)	COM-POWER	PAM-840	461257	25-Aug-15
Pre-Amplifier (1GHz~18GHz)	EM Electronics	EM30180	60558	23-Oct-14
Loop Antenna	Schwarzbeck	FMZB 1513	1513-076	28-Sep-14
EMI Test Receiver	R&S	ESC17	100797	23-Dec-14
LISN (1 phase)	R&S	ENV216	101243	30-May-15
LISN	Rolf Heine	NNB-2/16Z	99080	25-Aug-15

2.3 Traceability

All measurement equipment calibrations are traceable to NML(Taiwan)/NIST(USA) or where calibration is performed outside Taiwan, to equivalent nationally recognized standards organizations.

2.4 Calibration

Equipment requiring calibration is calibrated periodically in a suitably accredited Calibration Lab. Additionally all equipment is verified for proper performance on a regular schedule using in house standards or comparisons.

2.5 Measurement Uncertainty

The estimated combined standard uncertainty for radiated emissions and conducted emissions measurements .

Table 3: Emission Measurement Uncertainty

Parameter	Uncertainty
Radio Frequency	$\pm 1 \times 10^{-7}$
RF power, conducted	± 1.5 dB
RF power density, conducted	± 3 dB
spurious emissions, conducted	± 3 dB
all emissions, radiated	± 6 dB
Temperature	± 1 °C
Humidity	± 5 %
DC and low frequency voltages	± 3 %

3. General Product Information

3.1 Product Function and Intended Use

The EUT is a Mobile Accessory - Breathalyzer which can detector the Wine Concentration. It contains a Bluetooth 4.0(BLE) compatible module enabling the user to communicate data through a Wireless interface.

For details refer to the User Guide, Data Sheet and Circuit Diagram.

3.2 System Details and Ratings

Table 4: Basic Information of EUT

Item	EUT information
Kind of Equipment	Bluetooth Meridian
Type Designation	A02A
FCC ID	NHS-A02A IC Can ID:3653A-A02

Table 5: Technical Specification of EUT

Technical Specification	Value
Operating Frequencies	2402~2480 MHz
Channel Spacing	2 MHz
Channel number	40
Operation Voltage	3V DC
Modulation	GFSK
Antenna gain	-1.5 dBi

3.3 Independent Operation Modes

Basic operation modes are:

- A. Transmitting
 - 1. Low channel
 - 2. Middle channel
 - 3. High channel
- B. Receiving
- C. Standby
- D. Off

3.4 Noise Generating and Noise Suppressing Parts

Refer to the Circuit Diagram.

3.5 Submitted Documents

- Circuit Diagram
- Instruction Manual
- Rating Label
- Technical Description

4. Test Set-up and Operation Modes

4.1 Principle of Configuration Selection

The equipment under test (EUT) was configured to measure its maximum power level. The test modes were adapted accordingly in reference to the instructions for use.

4.2 Test Operation and Test Software

Setup for testing: Test samples are provided with a SPI interface which makes it possible to control them through a test software installed on a notebook computer.

This software was running on the laptop computer connected to the EUT. It was used to enable the operation modes listed in section 3.3 as appropriate.

The samples were used as follows:

Conducted:

Radiation: A000103946-003

Full test was applied on all test modes, but only worst case was shown

4.3 Special Accessories and Auxiliary Equipment

The product has been tested together with the following additional accessories:

Kind of Equipment	Manufacturer	Model Name	S/N
Laptop	HP	HSTNN-Q78C-3	CNF0339QBM

4.4 Countermeasures to achieve EMC Compliance

The test sample which has been tested contained the noise suppression parts as described in the Constructional Data Form or the Technical Construction File. No additional measures were employed to achieve compliance.

4.5 Test Setup Diagram

Diagram of Measurement Configuration for Radiation Test

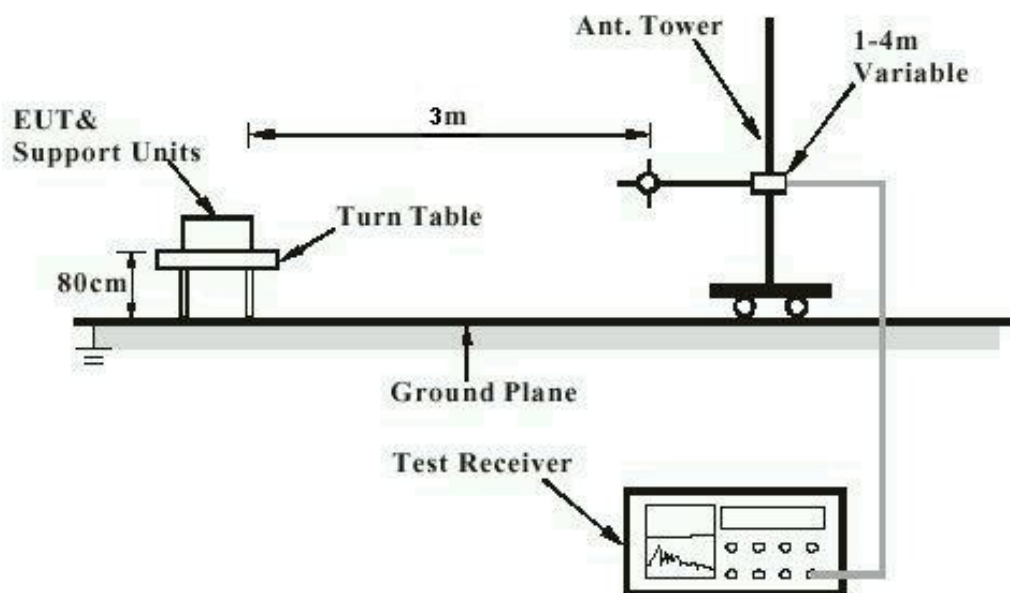

Diagram of Measurement Equipment Configuration for Mains Conduction Measurement (if applicable)

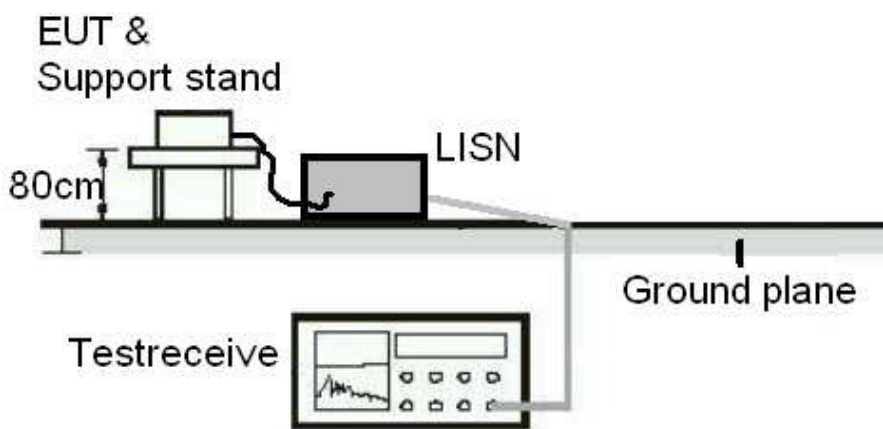
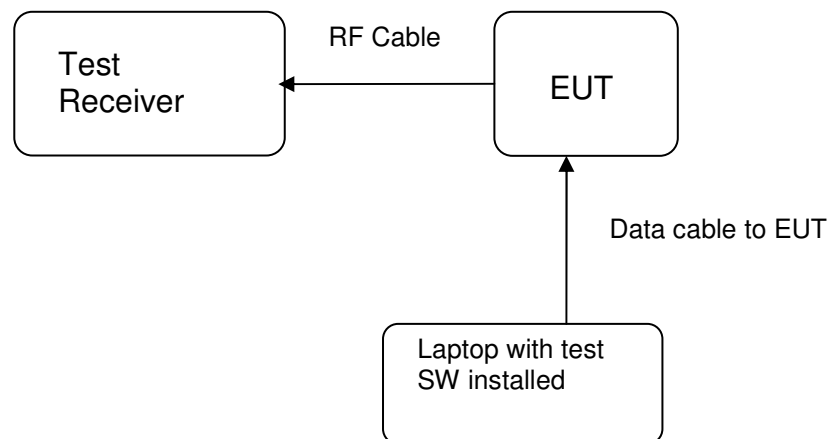

Diagram of Measurement Equipment Configuration for Conducted Transmitter Measurement



5. Test Results

5.1 Transmitter Requirement & Test Suites

5.1.1 Antenna Requirement

RESULT: **Passed**

Test standard : LP0002(2011): 2.2, 3.10.1, (3)
FCC Part 15.247(b)(4), Part 15.203 and RSS-
Gen 7.1.4

Requirement : use of approved antennas only with directional gains that
do not exceed 6 dBi

According to the manufacturer declaration, the EUT has an antenna with a directional gain of -1.5 dBi dBi. The antenna is a printed PCB trace with no possibility of replacement with a non-approved antenna by the end-user. Therefore, the EUT is considered to comply with this provision.

Refer to EUT photo for details.

5.1.2 Peak Output Power

RESULT:**Passed**

Test standard : LP0002(2011): 3.10.1, (2)
FCC Part 15.247(b)(3), RSS-210 A8.4(4)
Basic standard : ANSI C63.10:2009, KDB558074
Limit : 1 Watt
Kind of test site : Shielded room

Test setup

Test Channel : Low/ Middle/ High
Operation Mode : A
Ambient temperature : 20-24 °C
Relative humidity : 50-65 %
Atmospheric pressure : 100-103 kPa

Please refer to Bluetooth Module test report for details,

FCC ID: QDS-BRCM1078 ; IC:4324A-BRCM1078

5.1.3 6dB Bandwidth

RESULT:**Passed**

Test standard : LP0002(2011): 3.10.1, (5)
FCC Part 15.247(a)(2), RSS-210 A8.2(1)
Basic standard : ANSI C63.10:2009, KDB558074
Kind of test site : Shielded room

Test setup

Test Channel : Low/ Middle/ High
Operation Mode : A
Ambient temperature : 20-24°C
Relative humidity : 50-65%
Atmospheric pressure : 100-103 kPa

Please refer to Bluetooth Module test report for details,

FCC ID: QDS-BRCM1078 ; IC:4324A-BRCM1078

Prüfbericht - Nr.: 10042740 001

Test Report No.

Seite 17 von 24

Page 17 of 24

5.1.4 Power Density

RESULT:**Passed**

Test standard : LP0002(2011): 3.10.1, (6.2.2)
FCC Part 15.247(e) , RSS-210 A8.2(2)
Basic standard : ANSI C63.10:2009, KDB558074
Kind of test site : Shielded room

Test setup

Test Channel : Low/ Middle/ High
Operation Mode : A
Ambient temperature : 20-24°C
Relative humidity : 50-65%
Atmospheric pressure : 100-103 kPa

Please refer to Bluetooth Module test report for details,

FCC ID: QDS-BRCM1078 ; IC:4324A-BRCM1078

5.1.5 Conducted spurious emissions and Frequency Band Edge measured in 100kHz Bandwidth

RESULT:**Passed**

Test standard : LP0002(2011): 3.10.1, (5)
FCC part 15.247(d), RSS-210 A8.5
Basic standard : ANSI C63.10:2009, KDB558074
Limit : 20dB (below that in the 100kHz bandwidth within the
band that contains the highest level of the desired power)
Kind of test site : Shielded room

Test setup

Test Channel : Low/ High
Operation mode : A
Ambient temperature : 20-24°C
Relative humidity : 50-65%
Atmospheric pressure : 100-103 kPa

Please refer to Bluetooth Module test report for details,

FCC ID: QDS-BRCM1078 ; IC:4324A-BRCM1078

5.1.6 Spurious Emission

RESULT:**Passed**

Test standard	:	FCC part 15.247(d), FCC 15.205, FCC 15.209, RSS-210 2.2, RSS-210 A8.5 and RSS-Gen 7.2.1 LP0002(2011): 3.10.1, (5)
Basic standard	:	ANSI C63.10: 2009
Limits	:	Radiated emissions which fall in the restricted bands, as defined in FCC 15.205(a) and RSS-210 2.7 (Table 1), must comply with the radiated emission limits specified in FCC 15.209(a) and RSS-210 2.7 (Table 2 and 3). Radiated emissions which fall in the restricted bands, as defined in LP0002(2011): 2.7 , must comply with the radiated emission limits specified in LP0002(2011): 2.8 Emission radiated outside the specified frequency bands must comply with the radiated emission limits specified in FCC 15.209(a) and FCC 15.249(a), RSS-210 2.7 (Table 2 and 3) and RSS-210 A2.9(a). Emission radiated outside the specified frequency bands must comply with the radiated emission limits specified in LP0002(2011): 2.8
Kind of test site	:	3m Semi-Anechoic Chamber

Test setup

Test Channel	:	Low/ Middle/ High
Operation mode	:	A, B

Remark: Testing was carried out within frequency range 30MHz to the tenth harmonic.

For details refer to Appendix D.

Testing was carried out within frequency range 30MHz to the tenth harmonic. For details refer to Appendix D. The Radiated Emissions testing was performed in the X, Y and Z axis orientation. The worst-case Axis orientation is recorded in this test report. Due to the small size of the product and that there are no inductive components of significant size, 9kHz to 30MHz frequency range is not tested based on technical judgment.

6. Safety Human exposure

6.1 Radio Frequency Exposure Compliance

6.1.1 Electromagnetic Fields

RESULT:**Passed**

Test standard : FCC KDB Publication 447498 D01 v05

The maximum peak output power of the transmitter is 1.8 mW.

Hence the EUT is excluded from SAR evaluation.

Please also refer to FCC KDB publication 447498 D01 v05: Mobile Portable RF Exposure

Please also refer to Bluetooth Module test report for details,

FCC ID: QDS-BRCM1078 ; IC:4324A-BRCM1078

7. Photographs of the Test Set-Up

Photograph 1: Set-up for Spurious Emissions (Front View)

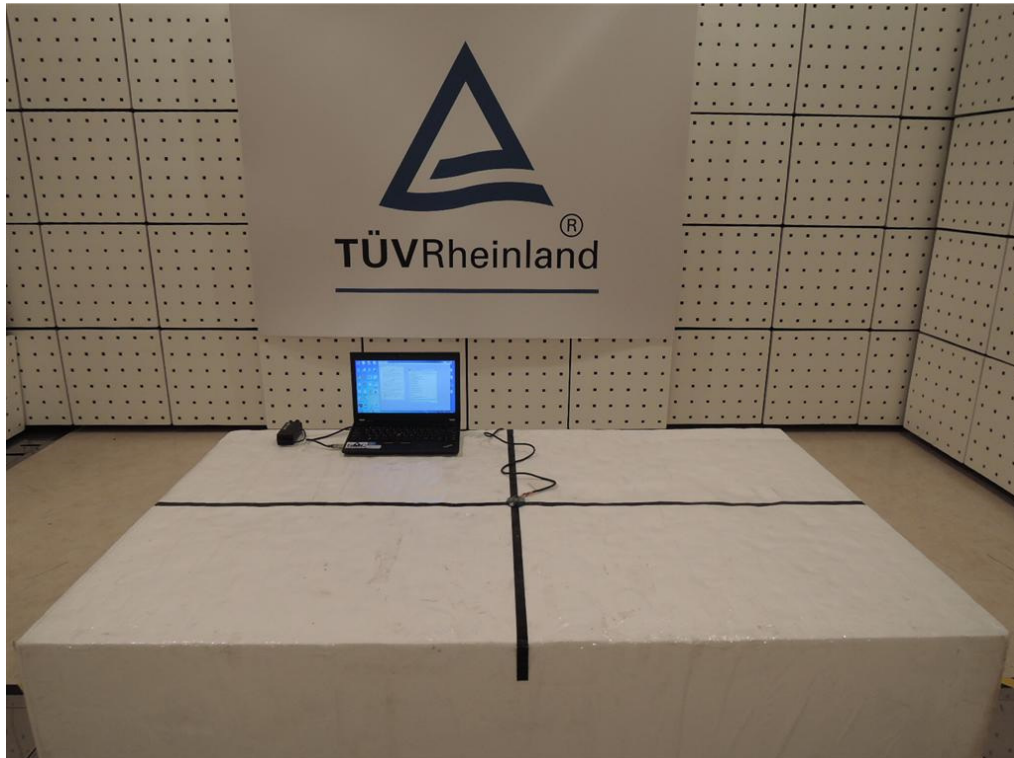

Photograph 2: Set-up for Spurious Emissions (Back View 1)

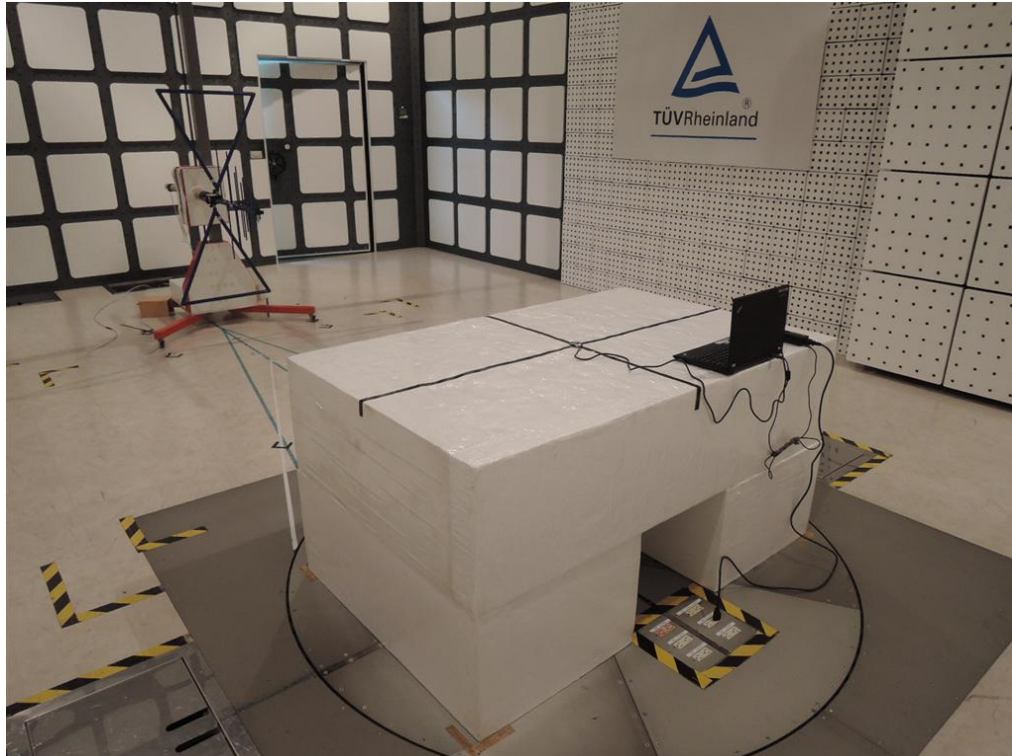

Photograph 3: Set-up for Spurious Emissions (Back View 2)

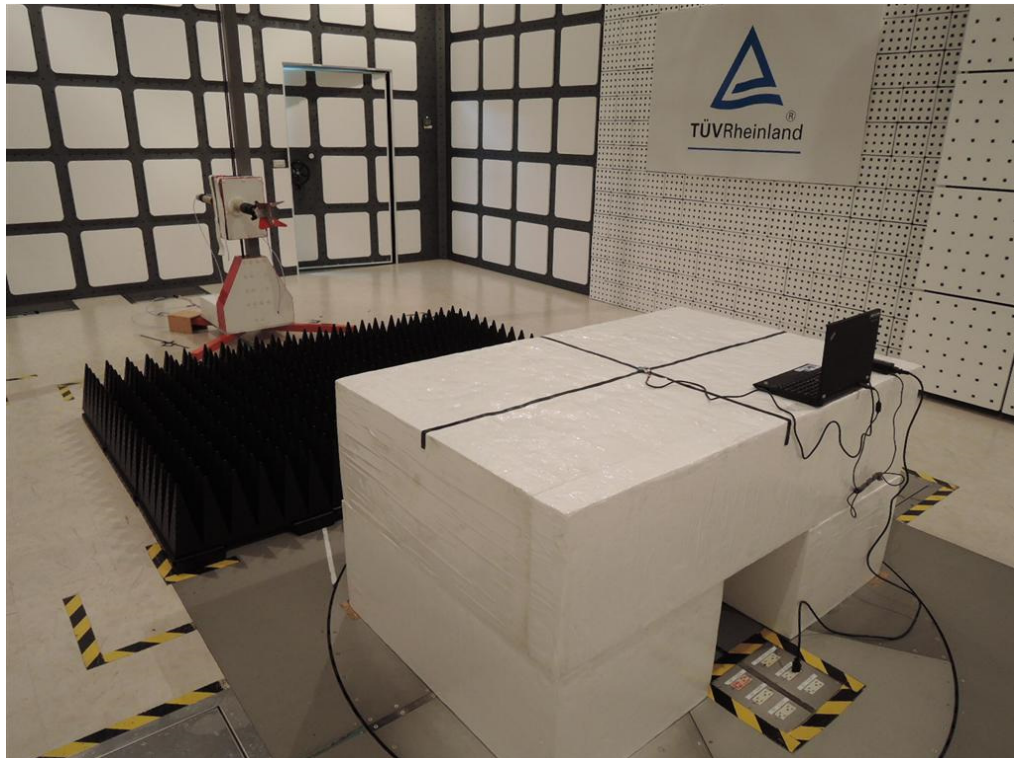

8. List of Tables

Table 1: Applied Standard and Test Levels	5
Table 2: List of Test and Measurement Equipment	7
Table 3: Emission Measurement Uncertainty.....	8
Table 4: Basic Information of EUT	9
Table 5: Technical Specification of EUT	9

9. List of Photographs

Photograph 1: Set-up for Spurious Emissions (Front View).....	21
Photograph 2: Set-up for Spurious Emissions (Back View 1)	22
Photograph 3: Set-up for Spurious Emissions (Back View 2)	23