

**The LOAD & A-2-B Company Inc.**

# **Cranesmart™ LMI System**

## **Installation and Operating Manual**

*“Congratulations! You have invested in the industry’s  
leading technology in crane safety equipment.  
Thank you very much for your business”*

**The contents of this manual must be read  
and thoroughly understood before operating the  
crane with this equipment installed**

**For sales, service or assistance:  
1-888-562-3222 / (780) 437-2986  
[www.cranesmart.com](http://www.cranesmart.com)**

**Please have the serial number of your system handy before calling to purchase batteries or to ask for  
technical assistance. You can find the serial number on either the receiver panel or the transmitters.**

Please see page 54 for FCC Compliance

# Table of Contents 1

<b>Foreword</b>	<b>– Installation guidelines, tools required</b>	<b>4</b>
<b>Section One</b>	<b>Contents</b>	<b>5</b>
	– LOAD CELL installation	6-8
	– ANTI-2-BLOCK installation and explanation	9-13
	– ANGLE SENSOR installation	14
	– RECEIVER/DISPLAY PANEL installation	15
	– ALARM HUB installation and explanation	16
	– SHUT OFF configuration	17
	– ANTENNA installation	17
<b>Section Two</b>	<b>Contents</b>	<b>19</b>
	– Cranesmart™ Load Moment Indicator panel functions	20
	– PANEL BUTTON definitions and use	20
	– FIRST TIME system start up, LOAD CHART information	21
	– Correct WINCH in use selection	21
	– Correct CHART in use selection	21
	– Correct PARTS-OF-LINE selection	22
	– PRIMARY OPERATING DISPLAY explained	22
	– SECONDARY OPERATING DISPLAY explained	23
<b>Section Three</b>	<b>Contents</b>	<b>25</b>
	– LOAD CELL calibration – KNOWN WEIGHTS explained	26-29
	– ANGLE SENSOR SIDE selection	30-32
	– ANGLE ZERO calibration	33-35
	– ANGLE SENSOR SELECTION for use (main or jib)	36-38

## Table of Contents 2

<b>Section Four</b>	<b>Contents</b>	<b>39</b>
	– Selecting WINCH LINE in use	40
	– Setting LOAD MINIMUM alarms	41
	– Setting LOAD MAXIMUM alarms	42
	– To ENABLE TARE OUT function	43-44
	– To DISABLE TARE OUT function	44
	– Setting ANGLE MINIMUM alarms	45
	– Setting ANGLE MAXIMUM alarms	46
	– Setting RADIUS MINIMUM alarms	47
	– Setting RADIUS MAXIMUM alarms	48
	– Setting TIP HEIGHT MINIMUM alarms	49
	– Setting TIP HEIGHT MAXIMUM alarms	50
<b>Section Five</b>	<b>Contents – Bypass key instructions</b>	<b>51</b>
	– Trouble-shooting for panel, battery and system lights	52
	– No communication between transmitters and panel	53
	– System technical component specifications	54
	– Warranty	54

### **Warranty**

The Load & A-2-B Company Inc. warrants to the purchaser of each new Cranesmart™ System that any part thereof which proves to be defective in material or workmanship within two (2) years from date of delivery will be repaired or replaced at no charge, if the system is returned to us in Edmonton, Alberta with all freight charges prepaid. If a performance problem should occur, contact our office in Edmonton, Alberta at 1-888-562-3222.

This warranty does not cover defects resulting from accident, alteration, improper use, or failure of the purchaser to follow normal operating procedures as outlined in this instruction manual. **PLEASE NOTE: OPENING THE BLUE RECEIVER PANEL VOIDS WARRANTY.**

THIS WARRANTY IS IN LIEU OF ANY WARRANTY OR MERCHANTABILITY AND OF ALL OTHER WARRANTIES, EXPRESSED OR IMPLIED, ALL OF WHICH ARE HEREBY EXCLUDED.

The Load & A-2-B Company Inc. shall in no event be liable for any special, indirect, or consequential damages whatsoever and neither assumes nor authorizes any person to assume for it any other obligation or liability.

**THIS LOAD MOMENT INDICATOR \*\*\*DOES NOT\*\*\*  
REQUIRE CALIBRATION.  
IT IS CALIBRATED AT THE FACTORY.**

**ATTENTION  
DO NOT CONSIDER THIS SYSTEM  
A SUBSTITUTE FOR GOOD JUDGMENT, EXPERIENCE  
AND ACCEPTED, SAFE CRANE OPERATING PRACTICES.**

-----  
**THE CONTENTS OF THIS  
MANUAL MUST BE READ AND THOROUGHLY  
UNDERSTOOD BEFORE OPERATING THE CRANE.**

-----  
**THIS SYSTEM UTILIZES A  
SERIES OF ELECTRICAL AND MECHANICAL  
COMPONENTS AND CANNOT BE 100% FAIL SAFE.**

### **Installation guidelines**

Read all of these instructions completely prior to beginning

- ⇒ 12 volt application only. Check voltage as a step down converter will be required if voltage is other than 12VDC
- ⇒ Mount the load cells, anti-2-block switches and or angle transducers first
- ⇒ Plan the installation
- ⇒ Have the necessary tools available
- ⇒ Mount the display panel second
- ⇒ Test the system

### **Tools required**

- ⇒ Man basket – to reach the boom, rooster sheave and or jib tip
- ⇒ Pliers for removing and bending cotter pins
- ⇒ Electric drill with various drill bits
- ⇒ Welder for attaching weld plated to boom/jib tips
- ⇒ Wire crimping tools – for the display power and ground connections
- ⇒ Screw drivers and or socket set
- ⇒ Clear silicone

# **Section One**

**This section provides  
information for placement  
and installation of the following components:**

- ⇒ **Load cells**
- ⇒ **Anti-2-block switches**
- ⇒ **Angle sensors**
- ⇒ **Receiver/display panel**
- ⇒ **Alarm Hub panel**
- ⇒ **Antennae**

# Load cell installation and placement guide for load cell links

**Figure 'A'** - Pin the **BLUE** load cell between the wire rope socket (becket) and the dead end on the main boom of the crane. **>MAIN<**

**Figure 'B'**- Pin the **YELLOW** load cell between the wire rope socket (becket) and the headache ball on the auxiliary sheave (rooster) on the cranes boom tip. **>AUX 1<** (Note: for two line load systems only)

**Figure 'C'**- Pin the **ORANGE** load cell between the wire rope socket (becket) and the headache ball on the jib extension. **>AUX 2<** (Note: for three line load systems only)

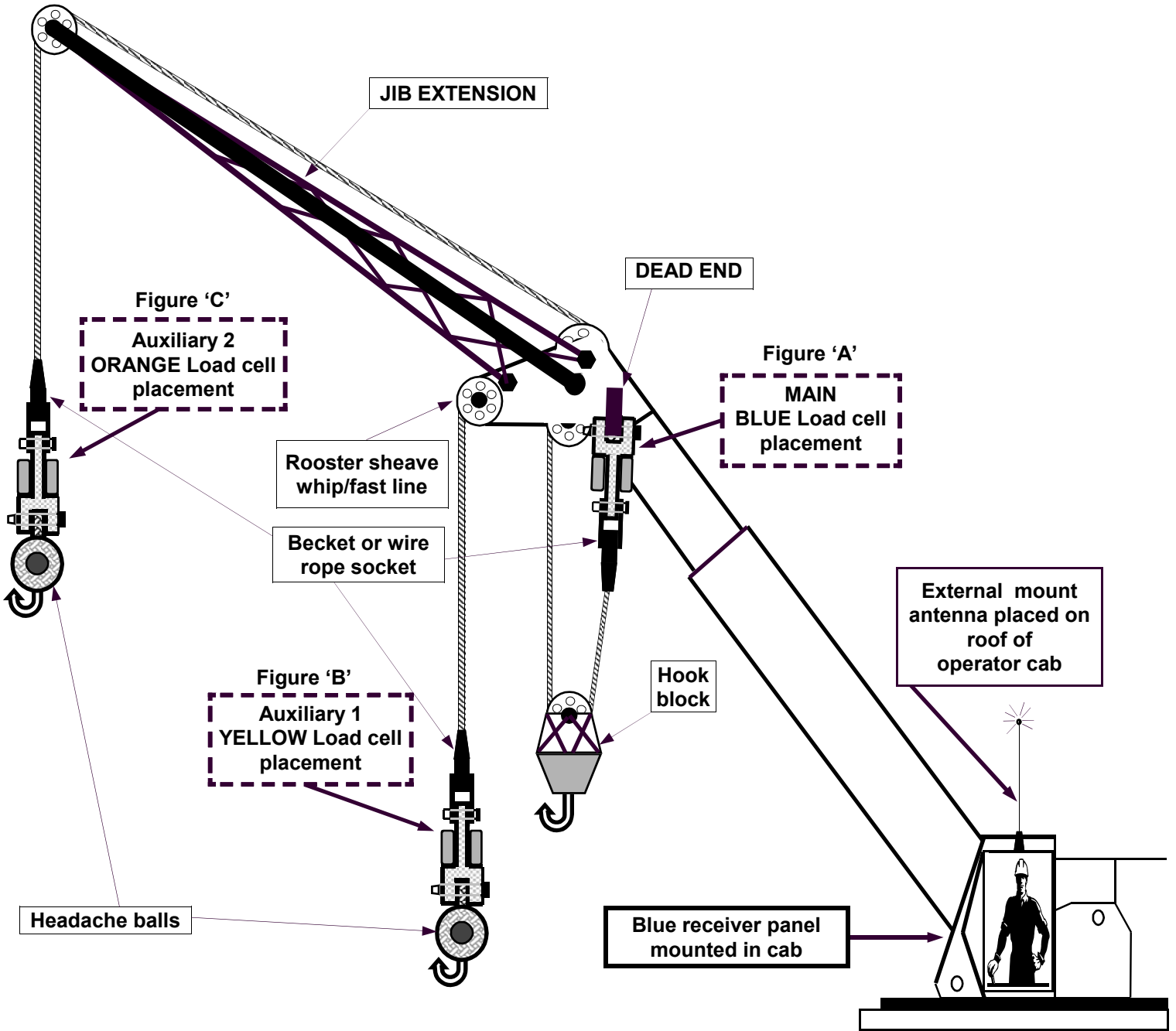

# 15,000 - 25,000 lb. SLP load cell installation instructions

## Male – Female - Load cell link Placement on BOOM TIP DEAD END Even part-of-line operation

For even parts-of-line, the load cell link is simply pinned between the wire rope (wedge) socket and the dead end on the boom tip as illustrated.

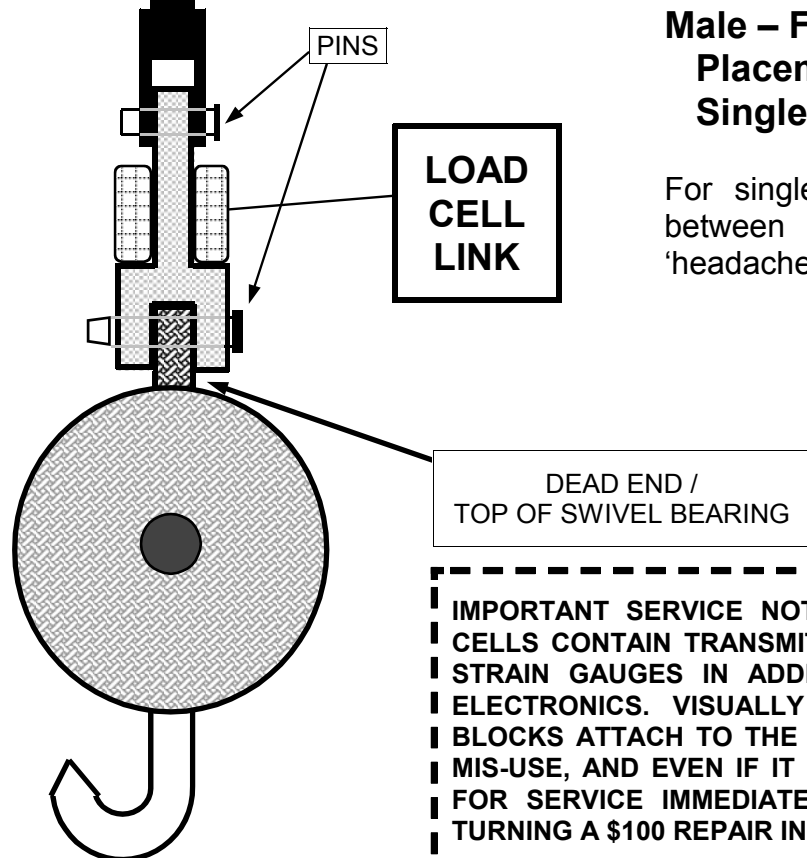
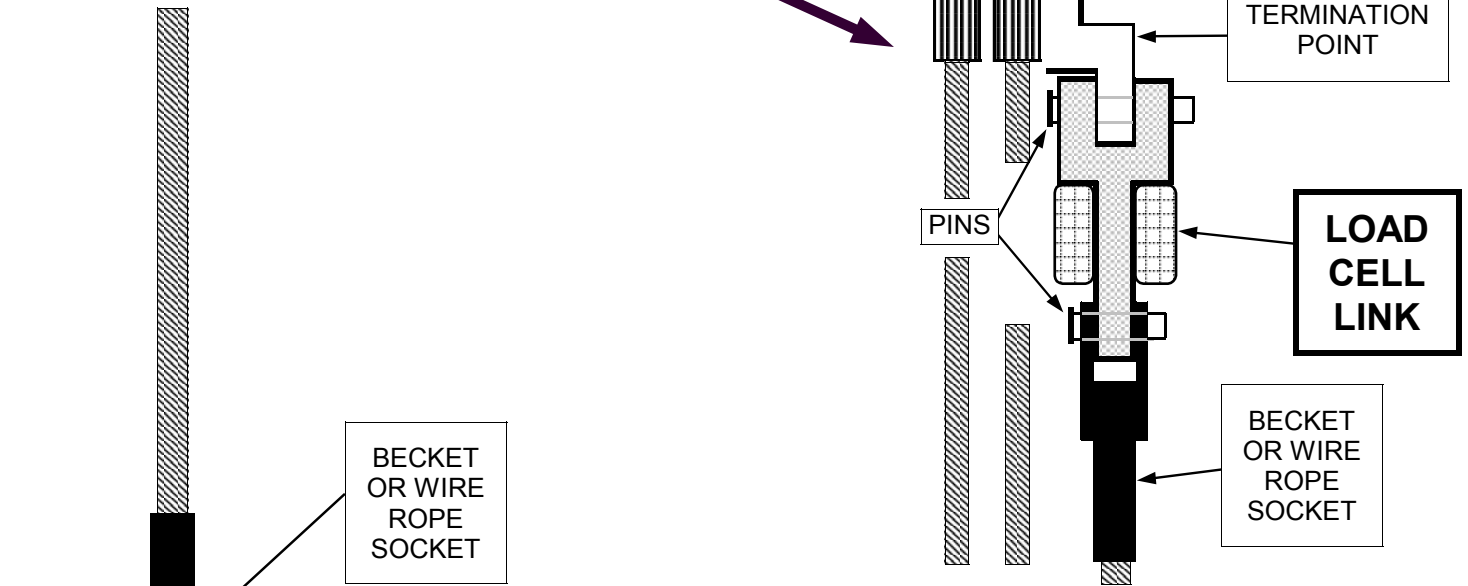

## Male – Female - Load cell link Placement on HEADACHE BALL Single part-of-line

For single part-of-line, the load cell link is pinned between the wire rope (wedge) socket and the 'headache ball' or traveling block.

**IMPORTANT SERVICE NOTE: THE COLORED BLOCKS ON THE LOAD CELLS CONTAIN TRANSMITTERS, LITHIUM BATTERY PACKS, INTERNAL STRAIN GAUGES IN ADDITION TO VARIOUS MODERN TECHNOLOGY ELECTRONICS. VISUALLY INSPECT THE SEALS WHERE THE COLORED BLOCKS ATTACH TO THE LOAD CELL. IF A SEAL IS BROKEN DUE TO MIS-USE, AND EVEN IF IT CONTINUES TO WORK, SHIP THE SYSTEM IN FOR SERVICE IMMEDIATELY. THIS WILL PREVENT MOISTURE FROM TURNING A \$100 REPAIR INTO A \$700 REPAIR.**

# 40,000 - 50,000 - 80,000 lb. SLP load cell installation instructions

## Male – Male - Load Cell Link Placement on BOOM TIP DEAD END Even part-of-line

⇒ For even parts-of-line, the load cell link is simply pinned between the wire rope socket (bucket) and the dead end on the boom tip. Please follow the diagram below which illustrates the correct use of the 'sandwich link' rigging attachment for this load cell.

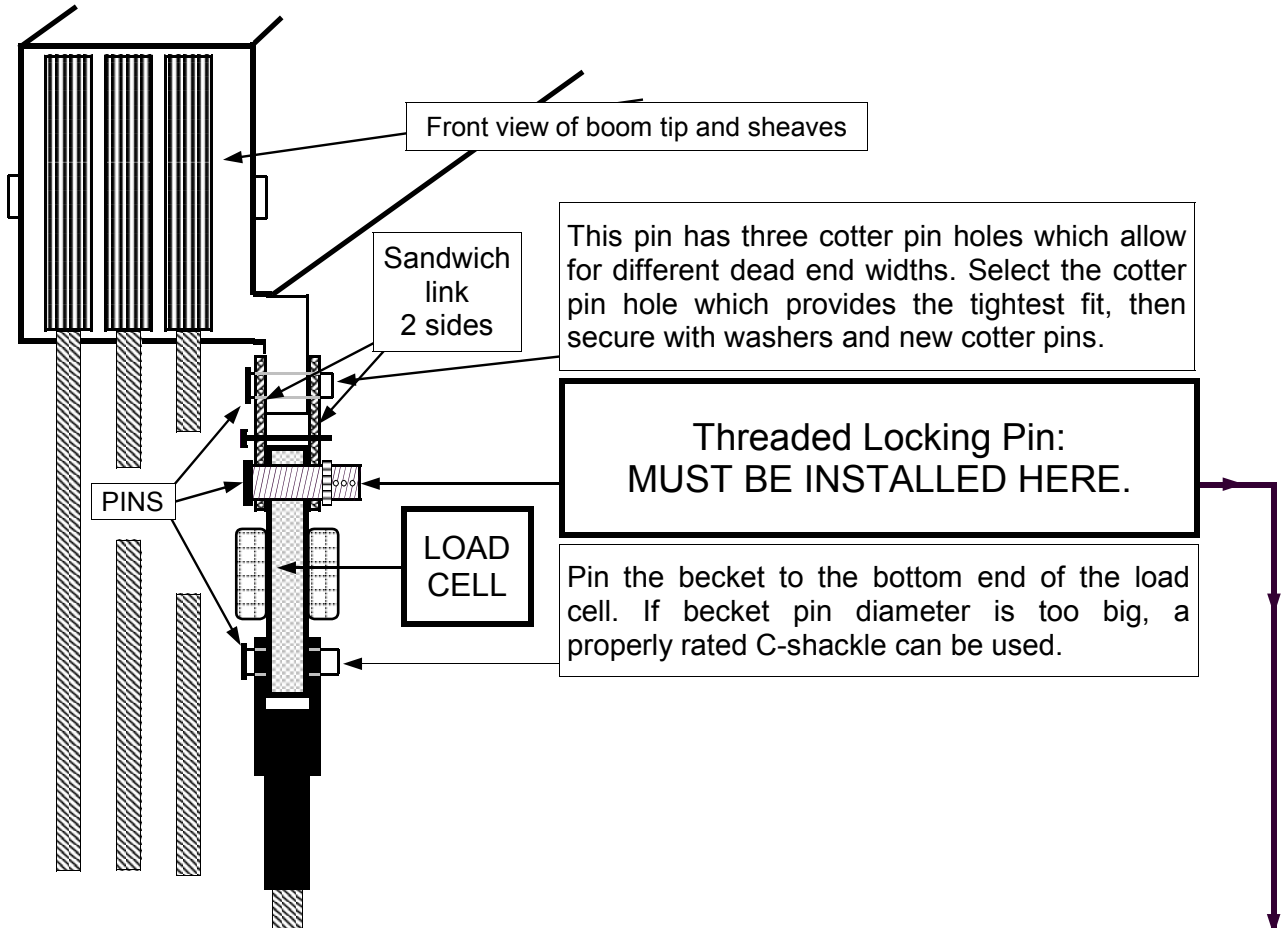

### Sandwich Link Stabilization Pin

**ATTENTION:** THIS PIN PREVENTS DAMAGE TO THE LOAD CELL BY KEEPING THE SANDWICH LINK FROM FOLDING AGAINST THE LOAD CELL IN A TWO BLOCK SITUATION. SUCH DAMAGE WILL NOT BE COVERED UNDER WARRANTY. CHECK THIS PIN REGULARLY TO ENSURE THAT IT IS SECURE & IN PLACE.

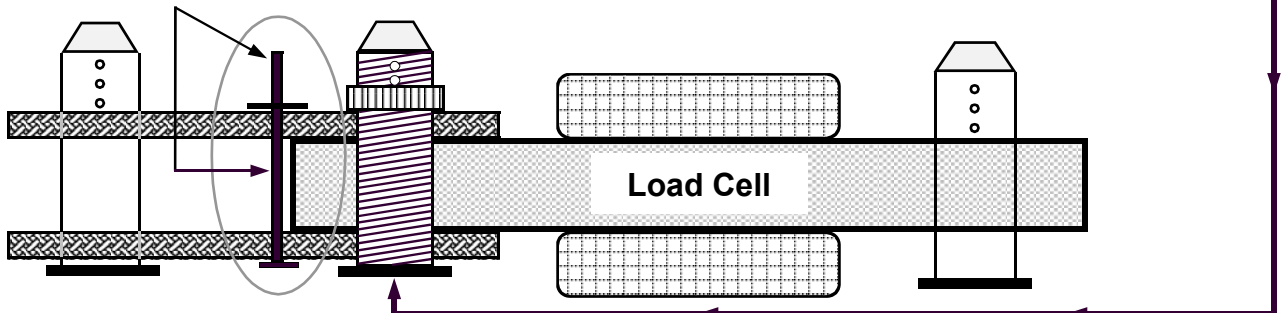



## Radio anti-2-block switch installation instructions

⇒ **Main Boom – Refer to Figures below to locate and install weld plate and A-2-B switch.**  
Please note that the weld plate & switch are shown larger than actual size for reference purposes.

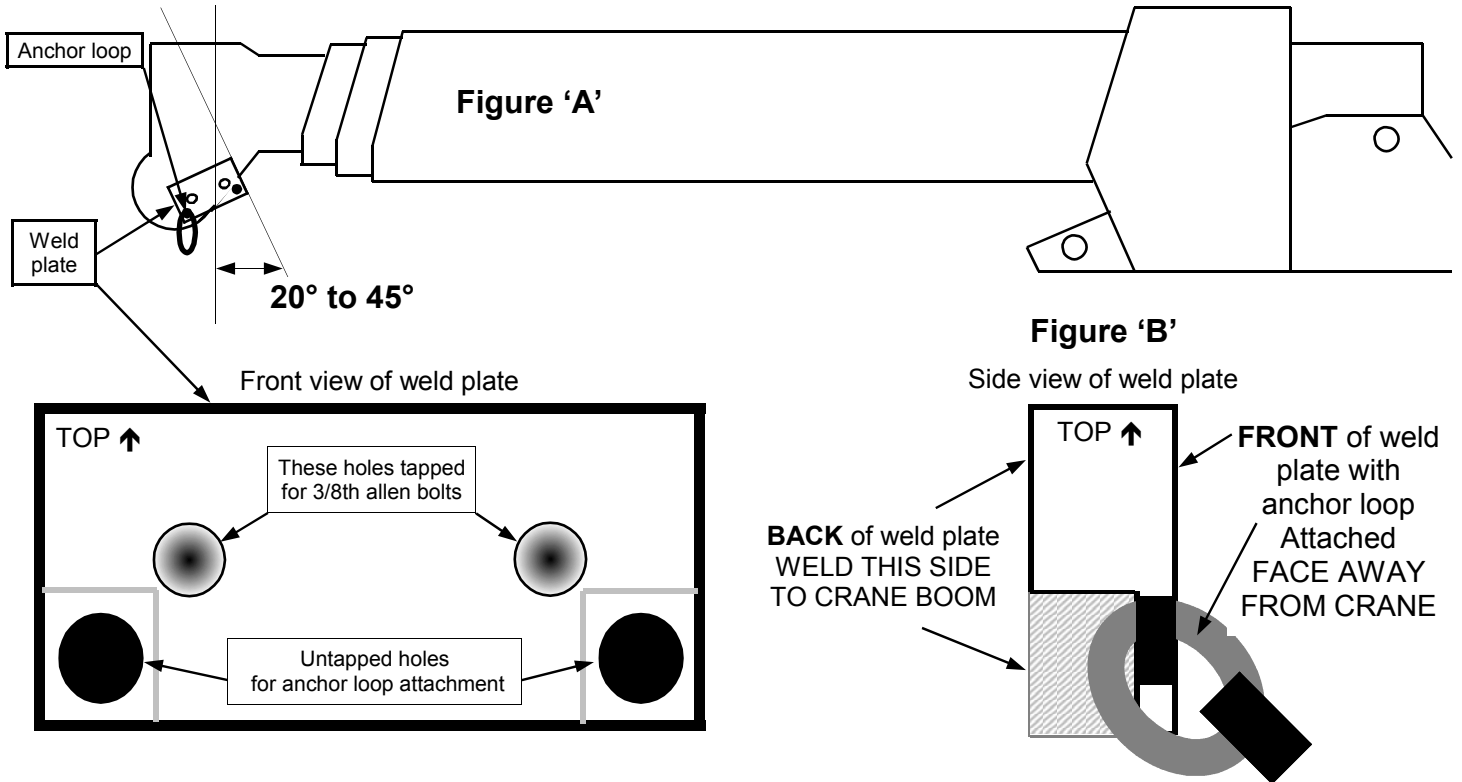

- ⇒ Ensure A-2-B switch and weld plate are attached. Place switch and weld plate at the desired location on boom tip, at a 20 to 45 degree angle as illustrated in Figure 'A' above and mark with a scribe. A 20 degree angle is ideal for a mobile hydraulic machine, a 40-45 degree angle is ideal for a conventional crane. Ensure that nothing will interfere with switch (such as a swing away jib extension, etc.) and that the antenna is not touching any metal on the boom.
- ⇒ Remove weld plate on A-2-B switch by unbolting the two 3/8th inch allen cap bolts. Weld the back of the weld plate as per Figure 'B' to the crane. Anchor loop should move freely once weld plate is welded. Note that weld plate should be offset at a 20-45 degree angle from the boom as illustrated in Figure 'A'.
- ⇒ After welding weld plate(s) to boom tip, allow weld plate to cool to the touch prior to mounting the A-2-B switch onto weld plate with the two allen bolts. Installed switch should now look like Figure 'C' below. It should be positioned directly above the dead end or slowest speed line. Ensure that the location of the switch is such that the line of sight is not blocked from the cab by any brackets or flanges.
- ⇒ Install the chain onto the cable loop on the bottom of the A-2-B switch. Attach the counter weight to the dead end line or the slowest speed line.
- ⇒ Repeat this procedure for rooster sheave (Aux. winch 1) and or jib extension (Aux. winch 2) A-2-B switch installations.

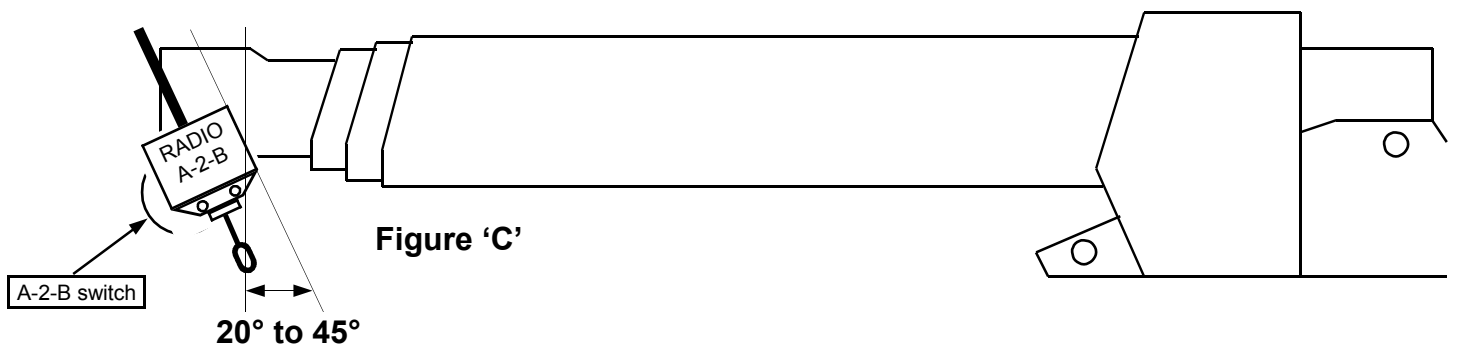

## Radio Anti-2-Block installation and placement guide

**Figure A** - Location of radio anti-2-block switch on main boom of crane.

**Figure B** - Location of radio anti-2-block switch on 'rooster sheave' or Auxiliary winch 1.

**Figure C** - Location of radio anti-2-block switch on 'jib extension' or Auxiliary winch 2.

**Figure D** - Location of external magnetic mount antenna on operator cab of crane.

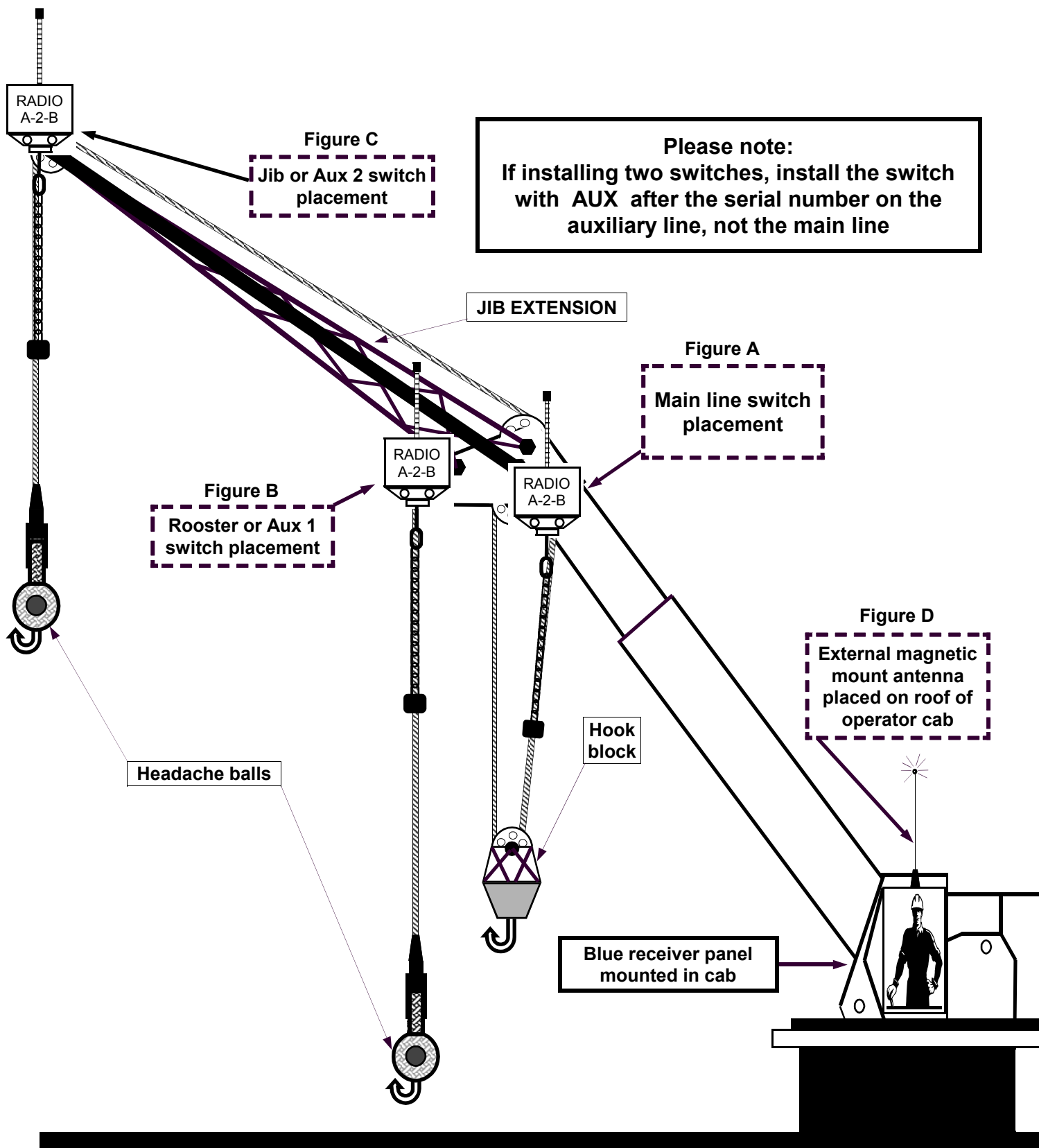

# Optional Fast Line Counterweight – single part of line only

## Installation – hanging procedure

Install weld plate for A2B switch as per instructions on page 4 of this manual. Weld second weld plate to opposite side of boom close to the bottom of the boom tip with the quick link hanging away and down. Attach counterweight **cable** to the bottom of A2B transmitter using the quick link supplied. Attach counterweight **chain** to second weld plate on opposite side of the boom. Adjust the length with the chain links until counterweight sits level on the wire rope as illustrated. Slide wire rope into donut by following the simple illustration instruction below. Fast line counterweight installation is now complete.

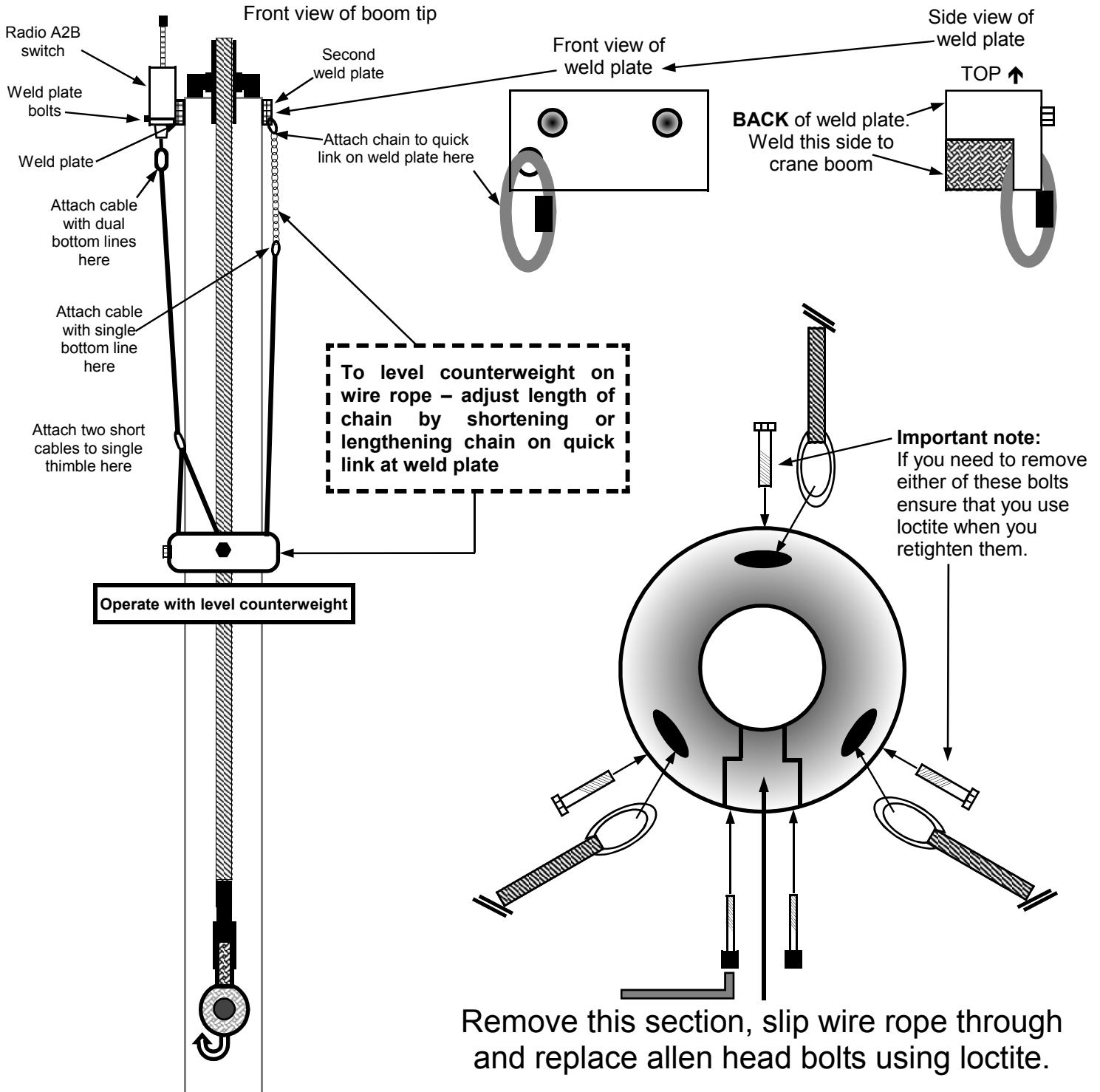

## Description of anti-2-block switch – red flagged transportation clip

- ⇒ The **Transportation Clip** with the red tag is a device which keeps the switch in a non-2-block state for transportation purposes. If you fold away your jib or remove a counterweight from a switch, ensure that the red flagged transportation clip is installed as illustrated. When transporting the crane long distances, ensure that you place the transportation clip in the bottom of the switch. This is done by allowing the weight to pull the switch into the non-2-block position, and inserting the red flagged transportation clip on the cable between the bottom of the aluminum collar on the switch and the metal grommet about 5/8th's inch below on the cable.
- ⇒ If you loose this transportation clip it will not affect the normal operation of the anti-2-block system
- ⇒ **Please note:** The red flagged transportation clips are to be removed from the bottom of the switch for normal system operation. If left in the switch the crane: **WILL NOT HAVE ANTI-2-BLOCK PROTECTION.**

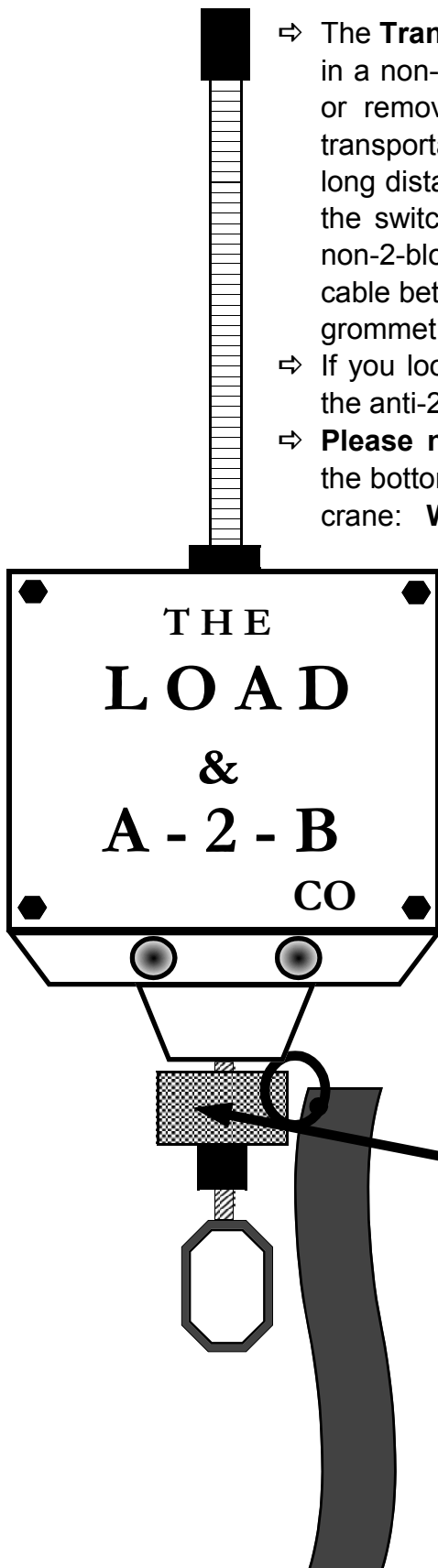

**\* I M P O R T A N T \***  
REMOVE RED FLAGGED TRANSPORTATION CLIP FOR  
SYSTEM OPERATION  
REPLACE WHEN MOVING OR TRANSPORTING CRANE

Red flagged transportation clip.

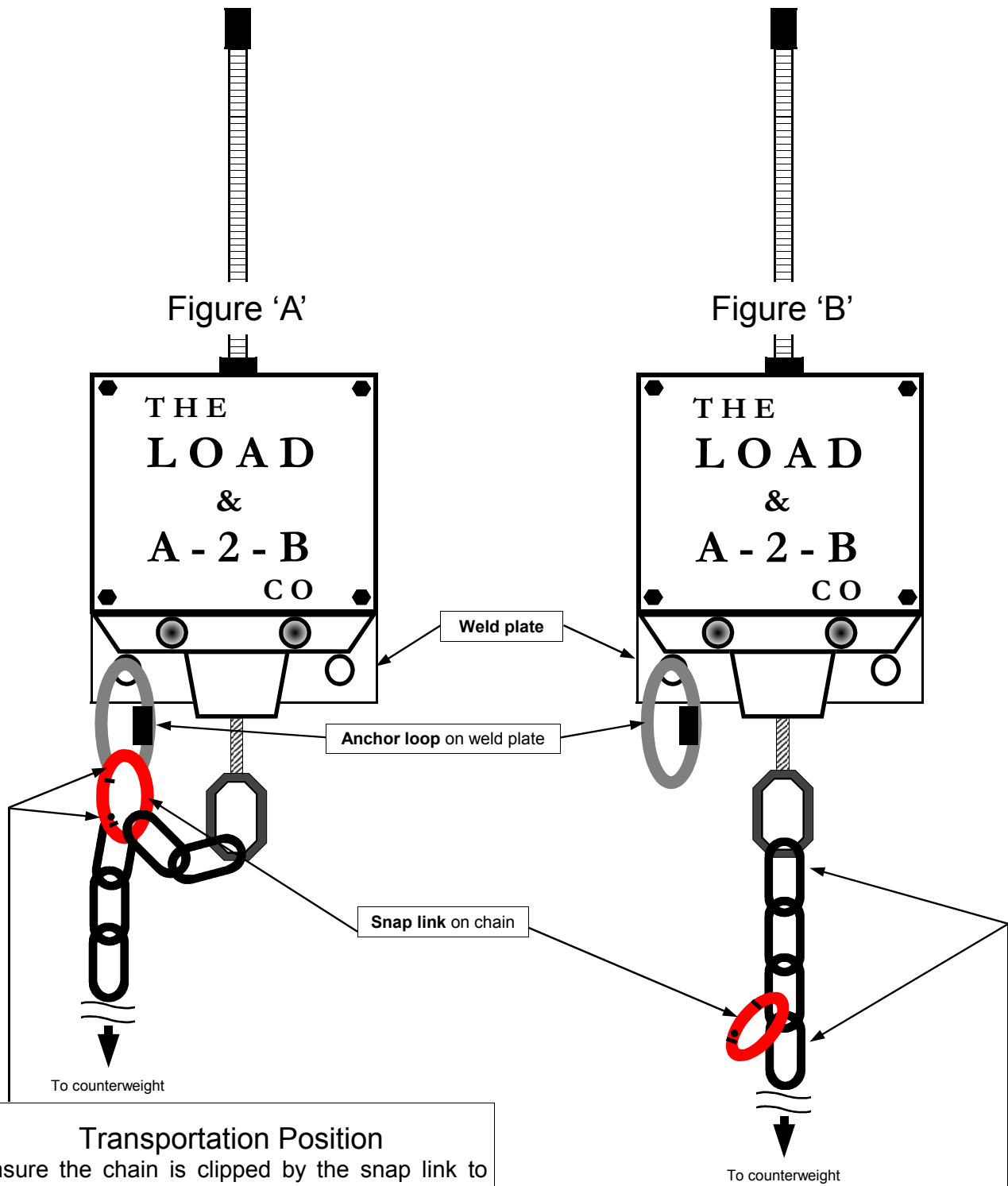

### Transportation Position

Ensure the chain is clipped by the snap link to the anchor loop on the weld plate when transporting the crane. See Figure 'A'. This will prevent damage and/or premature wearing of the cable at the bottom of the anti-2-block switch. Use the snap link to attach the chain to the anchor loop on the weld plate. Chain assembly should look like Figure 'A'. **Please note: The A-2-B system will report a TWO-BLOCK ALARM when the blue receiver panel is powered up to remind the crane operator to unclip the chain for operation.**

### Operating Position

Ensure the chain is not clipped to the anchor loop by the snap link when operating the crane. The snap link should be hanging freely. (as illustrated in above Figure 'B'). Chain assembly should look like Figure 'B'. **Please note: Test the system daily by lifting the counterweight and confirm an audio and visual alarm on the blue receiver panel.**

## Radio boom angle sensor installation instructions

⇒ The angle sensor must be installed on the boom at a minimum distance of ten feet from the antenna on the cab of the crane. The sensor can be mounted on either side of the boom however **the default setting is for installation on the LEFT SIDE of the boom**. If you determine that the right side of the boom is a more desirable location for the sensor you must program the panel for right boom operation – see section 3 of this manual after you have installed the angle sensor on the boom. Line of sight between sensor antenna and antenna should exist in all positions. Do not mount sensor on the top or bottom of the boom. Position the sensor weld plate assembly parallel with the boom line. Use the illustration on the Sensor label as an alignment aid.



⇒ Exact alignment is preferred but not necessary. Small alignment error can be zeroed out at the panel in the cab of the crane. Mark or scribe the boom where the weld plate will be mounted. Unbolt the weld plate from the angle sensor and lightly tack weld, do not permanently weld the plate yet. (see figure A below) PLEASE NOTE: Lightly tack weld plate where you think it should go, leaving the opportunity to move, adjust and re-weld if necessary, before testing the system for operation. Make certain that the antenna on the boom angle sensor will not be touching any metal once mounted. **DO NOT ATTEMPT TO WELD THE WELD PLATE WHILE ATTACHED TO THE SENSOR. THE SENSOR WILL BE PERMANENTLY DAMAGED.** Once the weld has cooled, mount the sensor to the weld plate (see figure B below) using the bolts and lock washers supplied.

⇒ Now you will need to raise your boom to a minimum of a 45 degree angle then return it to level. Now you should proceed to zeroing the angle. You will find these simple instructions on page 33-35 of this manual.

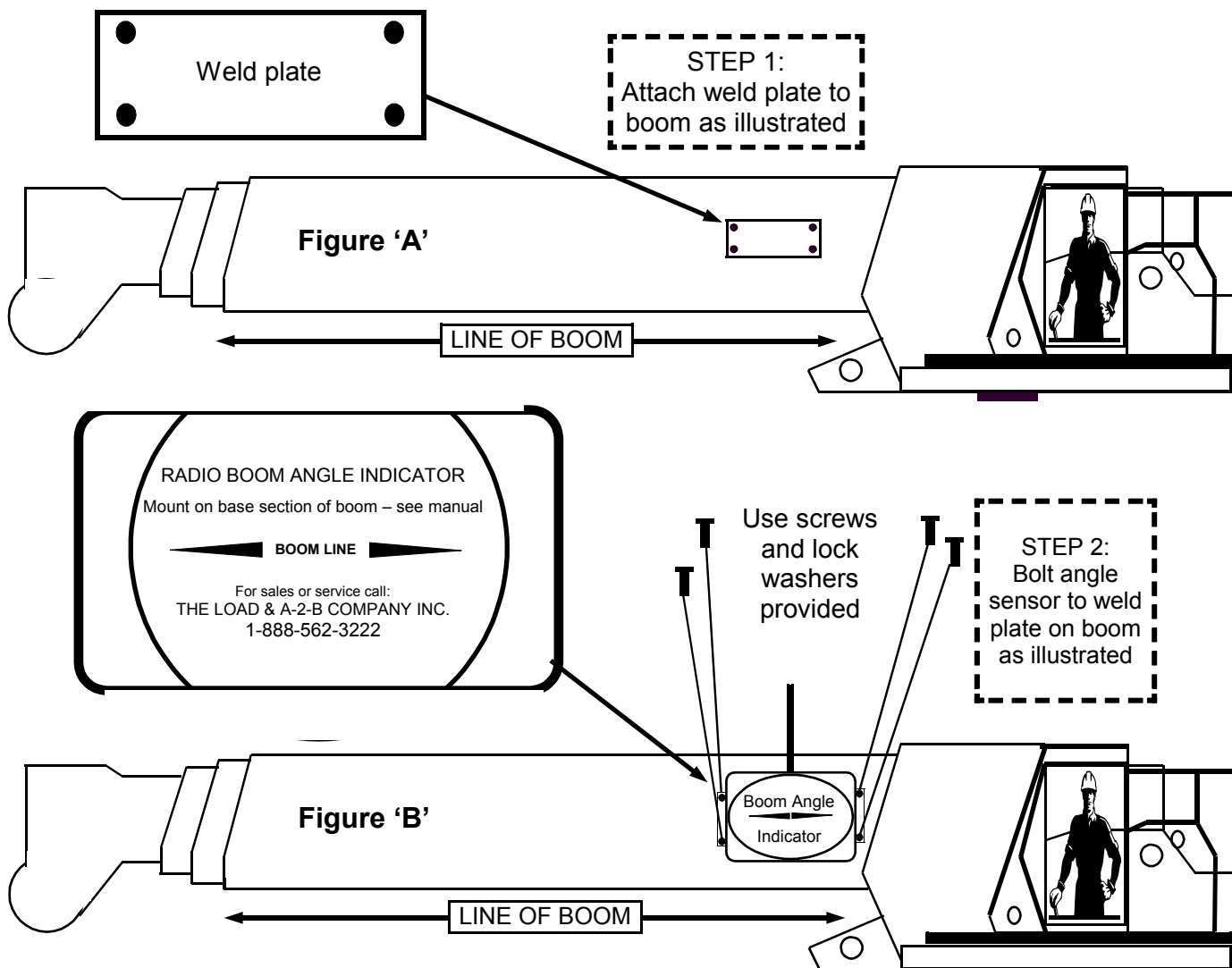

## Display panel installation instructions

- ⇒ **Display panel mounting:** The installation of the display panel consists of drilling two holes for mounting in the operator cab. First find a suitable location in the cab on the dash where the crane operator has an unobstructed view of the display. Using the removable bottom portion of the mounting bracket align, mark and drill two holes in the cab of the crane. Securely attach the bottom portion of the mounting bracket assembly to the dash. Place panel into the carriage holes of the lower mounting bracket and with the two fluted knobs and star washers, securely attach panel with the front of the display facing the operator.
- ⇒ **WITH ALARM HUB – Display panel power:** is provided to the panel using the four (4) pin interconnect cable included. The interconnect cable joins the alarm hub and the display panel together. **When attaching either end of the interconnect cable to the alarm hub and or the display panel, align the groove in the plug head with the groove in the panel or hub plug receptacle and insert gently – do not force. Lock plug on by gently rotating the collar of the plug a half turn clockwise.**
- ⇒ alarm hub wiring and alarm output instructions on next page.

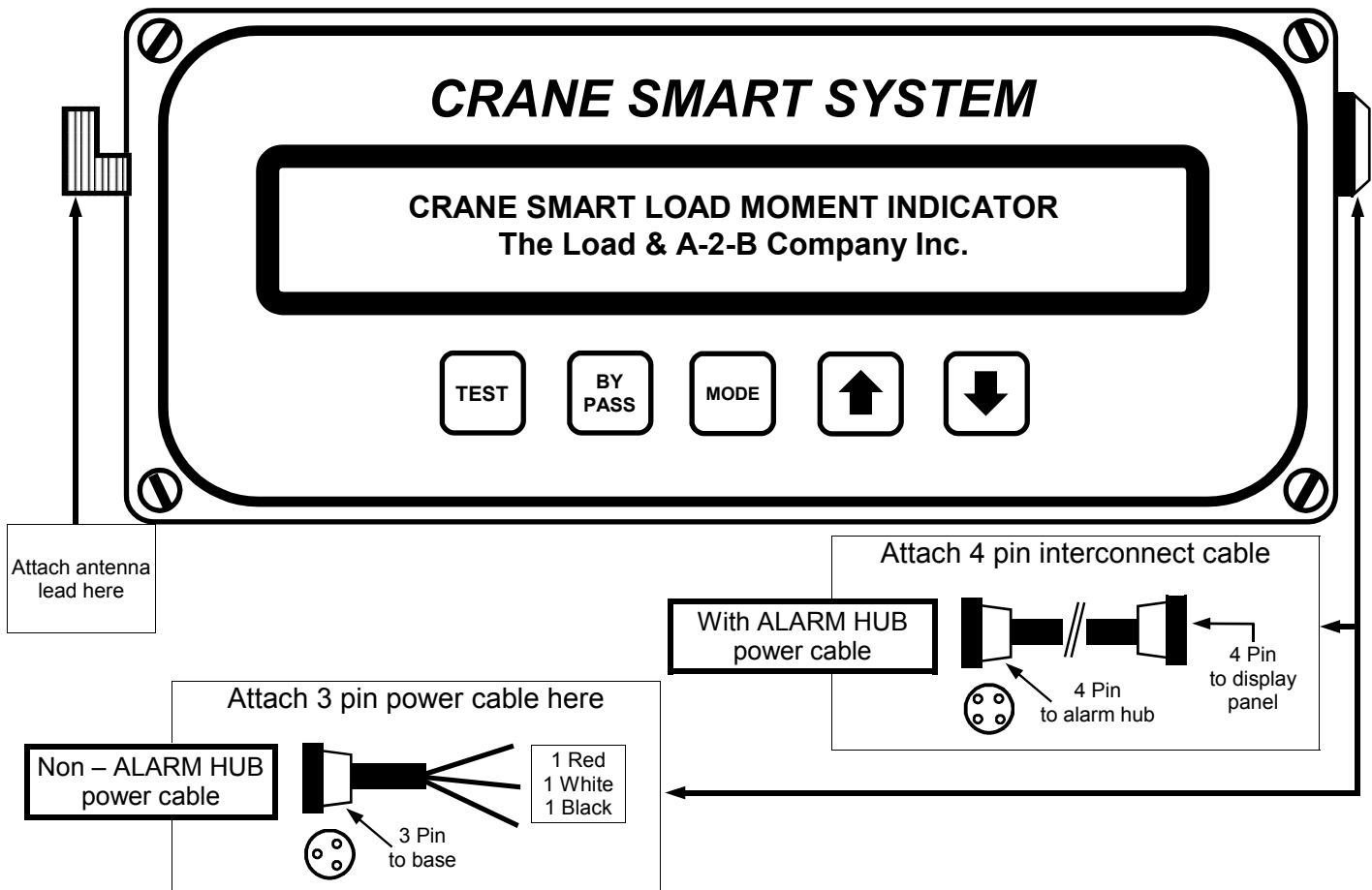

- ⇒ **Display panel power with NO ALARM HUB:** is provided to the panel using the three conductor cable included. Connect the red wire to a positive (+12VDC) terminal and the black wire to a solid ground on the crane. The third white wire is for optional shut offs or to sound external horns. **ATTENTION: Ensure that a continuous +12 VDC (11 volts minimum and typically 13.25 VDC with the engine running) is available to the panel at all times while the crane is in operation.** Otherwise the system will not operate correctly. When attaching power cable to panel gently push male end of plug into female panel receptacle. Slide plug neck back towards panel and tighten clockwise  $\frac{1}{2}$  turn.

**PLEASE NOTE:** If you have ordered your Cranesmart with classified area approvals such as Class I, Division II, for example – you must 'lock on' each end of the interconnect cable and alarm ports. Use the allen key provided to lock/unlock the cabling.

## Display panel installation instructions – With ALARM HUB

The alarm hub is an outboard extension of the Cranesmart display which allows up to three 12V 7.5A alarm outputs to be added to the Cranesmart system according to customer specifications. The alarm hub has an on board microcontroller which supervises the alarm relays for proper operation, hot or cold. The alarm hub communicates with the Cranesmart via an RS232 serial connection. You may mount this component out of the way, under the dash or on the side of the cab for example. It does not have to be visible by the operator.

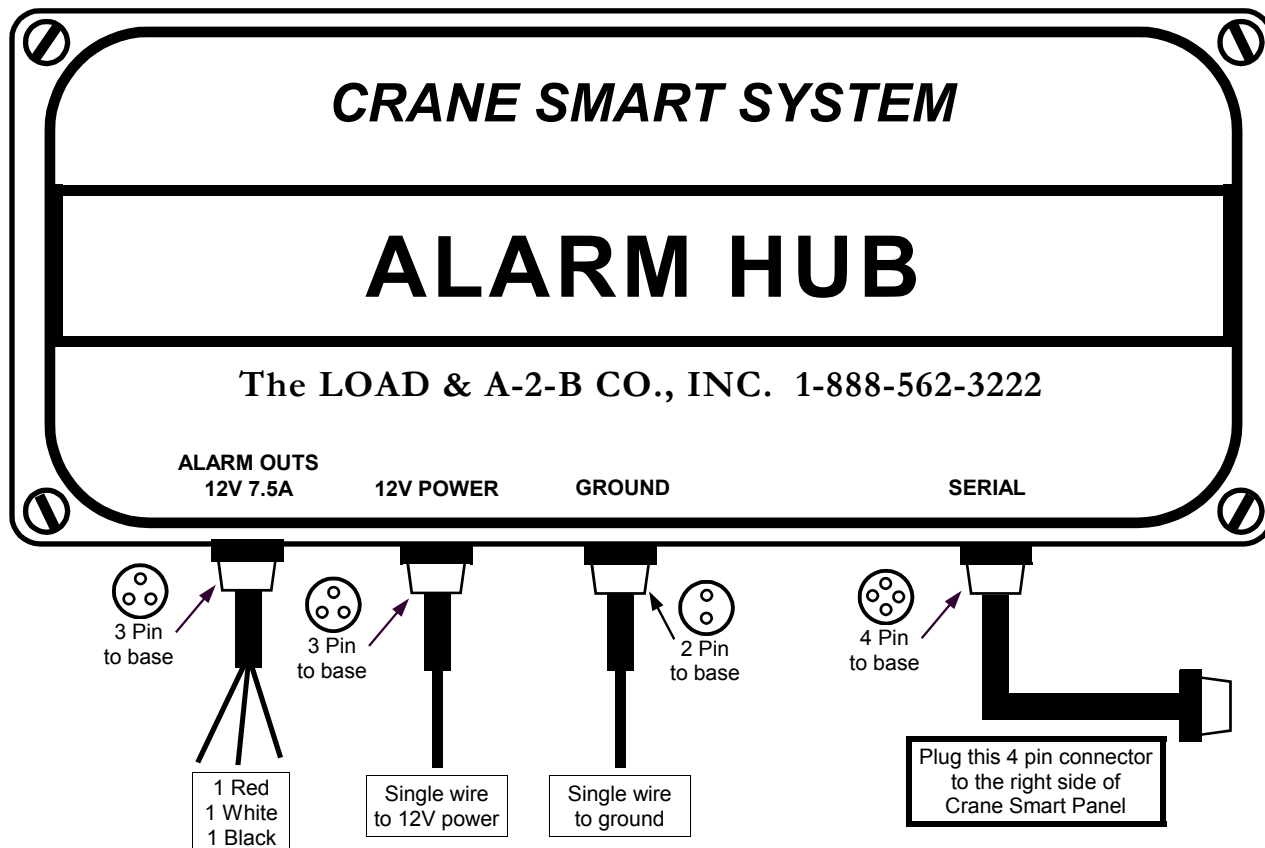

**Wiring instructions – four easy steps:** please take care when plugging in the finished connections. You must align the slot of the plug in the hole and then press together gently before locking.

- 1. ALARM OUTS:** Plug the 3 pin connector tagged Alarm Outs into the plug hole immediately below the ALARM OUTS label. The other end of the cable will have up to three wires. You will find a tag on the cable itself which will identify what output (load, angle or A-2-B) is signaled on each wire.
- 2. 12V POWER:** Plug the 3 pin connector tagged 12V POWER into the plug hole immediately below the 12V POWER label. The other end of the cable will have a single wire to attach to power.
- 3. GROUND:** Plug the 2 pin connector tagged GROUND into the plug hole immediately below the GROUND label. The other end of the cable will have a single wire to attach to ground.
- 4. SERIAL or INTERCONNECT cable:** Locate the power cable with a 4 pin plug on either end. To power the Cranesmart display panel you will need to plug one end of the 4 pin cable into the port labeled SERIAL on the ALARM HUB and the other into the Cranesmart display panel. This will provide both power and ground to the Cranesmart panel, while supporting the output relays for your crane shut-offs.

**PLEASE NOTE:** When a Cranesmart system is programmed for use with an alarm hub, the alarm hub must be present and working or the display will indicate an error condition as follows:

\*\*\* ALARM HUB MALFUNCTION \*\*\*  
Please Correct



## Shut off configurations for your system:

Normally each wire is identified with a tag to make installation of the shut-off circuits simple. If the tags are missing or if you are unsure – call our service department. Due to the many possible shut down configurations which your system may operate with, please consult THE LOAD & A-2-B Company for your particular crane. Please have the serial number of your system handy when you call 1-888-562-3222 or 1-780-437-2986.

---

### Antenna installation

Depending on the length or type of boom, four antenna installations and placements are possible. With your system you may have received:

- (A) One ten inch rubber antenna.
  - (B) One ten inch rubber antenna with an external magnetic mount base, attachment cable and plug.
  - (C) One metal whip antenna with an external magnetic mount base, attachment cable and plug.
  - (D) Marine specific antenna kit.
- (A) **Outside operator cab – up to 150 feet of boom:** Where the receiver panel is installed outside a cab simply install the 10 inch rubber antenna directly onto the blue receiver panel. Attach the base of the rubber antenna to the side of the receiver panel by inserting it GENTLY with a simple half turn.
- (B) **Inside operator cab – up to 150 feet of boom:** For installations inside the operator cab and where your boom **is less than 150 feet** of length, place the magnetic mount base with the 10 inch rubber antenna on the top of the operator cab and attach the antenna lead to the side of the receiver panel.
- (C) **Inside operator cab – more than 150 feet of boom:** For installations inside the operator cab and where your boom **is more than 150 feet** of length, place the magnetic mount base with the metal whip antenna on the top of the operator cab and attach the antenna lead to the side of the receiver panel. Please ensure the small allen screw for holding the whip antenna to the magnetic base is firmly tightened.
- (D) **Any MARINE application:** attach base with the metal whip antenna on the top of the operator cab on the crane attaching the antenna lead to the side of the receiver panel.

**At all times ensure that the lines of sight between the load cells, anti-2-block switches, angle transducers and the antenna on the cab of the crane are unobstructed. It is important that the receiver antenna NOT be touching glass or metal.**



## **Section Two**

**The load cell, anti-2-block switch, angle transducer and panel  
must all be installed  
before proceeding past this point of the manual.**

**This section provides information for:**

- ⇒ **Cranesmart™ Load Moment Indicator panel functions**
- ⇒ **Definitions of panel button controls and use**
- ⇒ **System start up**
- ⇒ **Load chart information**
- ⇒ **First time system start up**
- ⇒ **Correct load chart in use selection**
- ⇒ **Correct winch in use selection**
- ⇒ **Correct parts-of-line selection**
- ⇒ **Primary Operating Display explained**
- ⇒ **Secondary Operating Display explained**



## System start up

- ⇒ each and every time the receiver panel is powered up (example: each time the crane is started) the system will require operator input before it can be used.
- ⇒ on power up the panel will display the following 4 screens (FIG 1A – 1D) before operator input is required:

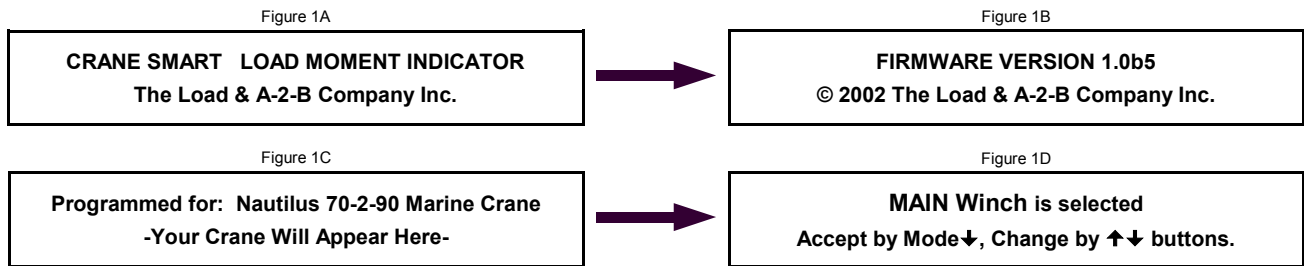

## Winch line selection

- ⇒ the system may indicate **MAIN winch is selected** as above (FIG 1D).
- ⇒ if you wish to change winch line selected, simply push either the **↑** or **↓** **button** on the panel until the winch line (Main, Aux. 1, Aux. 2) to be used is displayed on the screen.
- ⇒ once the correct winch line in use is displayed on the screen, accept by pressing and holding the **MODE** **button**, then press the **↓** **button** once.
- ⇒ the saving screen will appear for a few seconds. Proceed to load chart in use selection below.

**Please note that you will have a different load chart for your main and auxiliary winches. It is vital that you select the correct winch line in use as it will relate directly to its individual load chart.**

## Correct load chart in use selection

- ⇒ after you select and accept your winch line in use the Cranesmart system will prompt you to confirm which load chart you are using, such as static or dynamic, ABS, or API for some examples, as your system may be programmed with various load charts. You must select and accept the correct load chart with the correct parts-of-line each time you use the crane and this system. **This is vital.**
- ⇒ if you do not know what load chart or parts-of-line to select, ask your Foreman.
- ⇒ on every start up the – after you accept the winch line in use in the above step – the last used load chart will appear in the display screen – an example below:

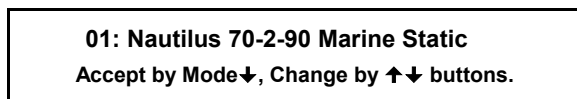

- ⇒ if you wish to select a different load chart other than what appears in the load chart selection display screen (above) simply push either the **↑** or **↓** **button** on the panel until the correct load chart is displayed.
- ⇒ once the correct load chart is displayed accept by pushing the **MODE** **button** and while holding it, push the **↓** **button** once. The saving screen will appear briefly.

⇒ **Proceed to next page**

## Correct parts-of-line selection:

- ⇒ all load charts programmed into this system are indexed to match with parts-of-line as per each load chart. This means that if you select a parts-of-line where there is no chart programmed for that specific parts-of-line, the system will not operate until you match POL with a programmed load chart.

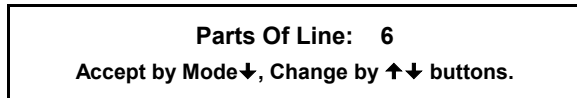

- ⇒ to change the parts-of-line in use setting simply push either the ↑ or ↓ button on the panel until the correct parts-of-line in use on your crane is displayed on the screen.
- ⇒ once the correct parts-of-line on the winch in use is displayed on the screen, accept by pressing and holding the **MODE** button, then press the ↓ button once. The **Saving Display** screen will appear for a few seconds. The **Primary Operating Display** will then appear on the screen similar to the display screen below.

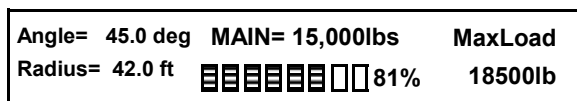

- ⇒ you are now ready to operate the crane.

## Operating displays and information:

- ⇒ During normal operation the Cranesmart has four display screens defaulting to with the Primary Operating display shown below. You may move from screen to screen with a simple push or either the up or down arrow button. After approximately ten seconds the system will always default to the Primary Operating display. This function can not be changed.

**Primary operating display** is the main operating display for the system.

After selecting the correct winch line in use, correct load chart and number of parts-of-line, the Crane Smart System will show the **Primary Operating Display** below:

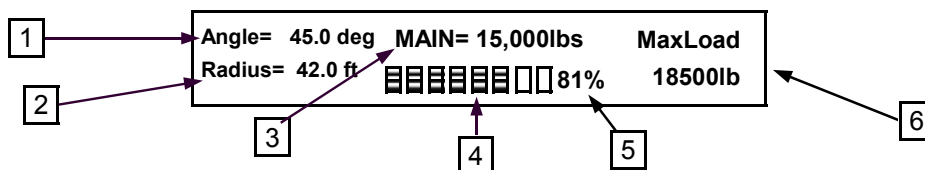

The top row displays the operator with the following functions as read from left to right:

1. **Angle=** is the actual live angle of the of the boom in degrees base section to the horizontal ground.
2. **Radius=** is the actual radius in feet as measured from the crane center of rotation to the center of the load.
3. **MAIN** is actual load on the hook. **MAIN** or **AUX1** will alternate continuously with **Load** on the this portion of the display to identify which winch line is currently selected for display.
4. **A BAR GRAPH** The shaded portion of the bar graph fills in from left to right as the load increases towards maximum chart. Blank with no load - completely filled in at 100% of chart.
5. **The percentage** of permitted load as per capacity charts is displayed.
6. **MaxLoad** is the actual maximum load (at 100%) allowed by the capacity charts and crane configuration.

## Check your load chart in use – display screen

The following information is displayed when the **↓ button** is pressed **once** from the Primary Operating Display. (bottom of last page) This display indicates current load chart and parts-of-line information. It will return to the Primary Operating screen in about ten seconds.

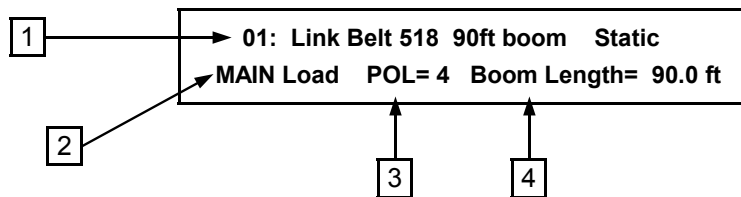

1. **01:** The top row displays details of the load chart in currently selected
2. **MAIN** is the selected winch. (may also be AUX1 or AUX2)
3. **POL=** indicates the actual parts-of-line in use on the selected winch (1-60).
4. **Boom Length=** should reflect the total length in feet of boom in use.

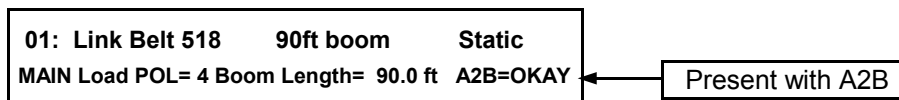

If you have an active anti-2-block switch or switches with your Cranesmart LMI system, you will see the **A2B=OKAY** information in the bottom right of this display as illustrated above.

## Check your transmitter(s) signal strength display

The following information is displayed when the **↓ button** is pressed **twice** from the Primary Operating Display (bottom of last page). This indicates the live signal strength of your boom mounted transmitters as received at the panel. The display will return to the Primary Operating screen in about ten seconds.

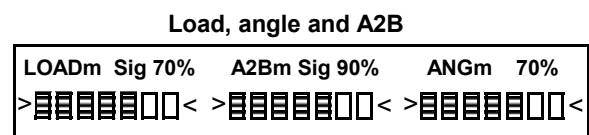
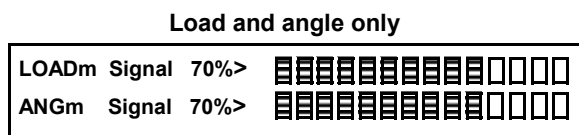

## Check your radius, live boom angle and tip height

The following information is displayed when the **↑ button** is pressed **once** from the Primary Operating Display (bottom of last page). This indicates the radius in feet, the live boom angle in degrees and the current tip height of the boom. The display will return to the Primary Operating screen in about ten seconds.

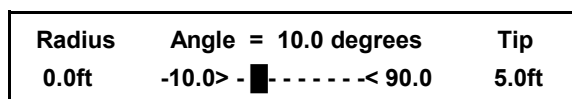





## **Section Three**

**The load cell, anti-2-block switch, angle transducer and panel  
must all be installed  
before proceeding past this point of the manual.**

**Please note:**

**You will require a permissions code to complete the following sequences:**

**This section provides information for:**

- ⇒ **Load cell calibration**
- ⇒ **Weight adjustment information**
- ⇒ **Restoring factory calibration**
- ⇒ **Angle side selection**
- ⇒ **Angle zero calibration**
- ⇒ **Angle sensor selection**

## Calibration options:

1. Calibration can be restored over the telephone in a matter of minutes as the load cells are designed to self-calibrate. Call our service department at 1-888-562-3222 and ask for the load cell self calibration instructions. Have the serial number of your system handy. OR
2. Follow the detailed calibration procedures detailed below.

**Before you start this calibration procedure, you must have a known weight. The minimum weight amount will depend on the load cells single line pull rating.**

For calibration a known weight of 50% or greater of the single line pull of the load cell is best. The weights used for calibration must be **known weights**. This is vital.

### Examples:

- ⇒ Using a **15,000 pound SLP load cell** and when running **4 parts-of-line**, the ideal known weight required for calibration purposes would be **30,000 pounds**.
- ⇒ Using a **25,000 pound SLP load cell** and when running **6 parts-of-line**, the ideal known weight required for calibration purposes would be **75,000 pounds**.
- ⇒ Using a **40,000 pound SLP load cell** and when running **8 parts-of-line**, the ideal known weight required for calibration purposes would be **160,000 pounds**.

The simple formula is:

- ⇒ **(Single line pull of load cell X parts-of-line ÷ 2 = minimum known weight required for calibration purposes)** Higher or lower weights may be used however the accuracy of the calibration may be affected.

**PLEASE READ THIS ENTIRE SECTION OF RE-CALIBRATION BEFORE PROCEEDING! DO NOT POWER UP PANEL UNTIL READ AND UNDERSTOOD COMPLETELY.**

- ⇒ load cell calibration. You must follow each of these steps in the sequence following to calibrate for each load cell, example Main, Auxiliary 1 and or Auxiliary 2.
- ⇒ please note that the system is calibrated from factory and does not normally require re-calibration before use.
- ⇒ set the ZERO value first and the SPAN value second.

**Steps to selecting winch prior to re-calibrating load cells – Each of these steps must be repeated for each load cell if you have a multi-line system.**

- ⇒ start with the panel displaying the Primary Operating screen below:

Angle= 45.0 deg	MAIN= 15,000lbs	MaxLoad
Radius= 42.0 ft	■■■■■■■■■■ 81%	18500lb

- ⇒ push the **↓ button once** to display your load chart information display screen below:

01: Link Belt 518 90ft boom Static
MAIN Load POL= 4 Boom Length= 90.0 ft

- ⇒ push and hold the **MODE** button in. While holding in the **MODE** button, push the **TEST** button once. The following display screen will appear:

Select Permission Code: 127
Accept by Mode↓, Change by ↑↓ buttons.

- ⇒ proceed to the top of the next page.

⇒ pressing the **↑** or **↓** buttons select **111** for permission code until display screen appears as follows:

Select Permission Code: 111  
Accept by Mode↓, Change by ↑↓ buttons.

⇒ save by pushing the **MODE** and **↓** button.  
⇒ the **Saving Screen** will then appear.  
⇒ the following screen will then be displayed:

MAIN Winch is selected.  
Accept by Mode↓, Change by ↑↓ buttons.

⇒ **select the winch you wish to calibrate** by pressing the **↑** or **↓** buttons.  
⇒ if correct winch for calibration is already displayed, save by pushing the **MODE** and **↓** buttons.  
⇒ the following display will then appear:

01: Static or your make and model of crane  
Accept by Mode↓, Change by ↑↓ buttons.

⇒ **select correct load chart in use** by pressing the **↑** or **↓** buttons. When the display indicates the correct load chart is use save by pushing the **MODE** and **↓** buttons.  
⇒ the following display will then appear:

Parts Of Line: 4  
Accept by Mode↓, Change by ↑↓ buttons.

⇒ if necessary change the parts-of-line by pressing the **↑** or **↓** buttons until the correct number of parts-of-line is displayed on the screen in above. Save by pushing the **MODE** and **↓** buttons.  
⇒ after the **Saving Screen** press the **↑** button once to return to the **Primary Operating Display**. This is an example of that display:

Angle= 45.0 deg MAIN= 15,000lbs MaxLoad  
Radius= 42.0 ft  81% 18500lb

⇒ from the above **Primary Operating Display** page down by pushing the **MODE** and **↓** buttons. Display screen will appear below:

Change Cal or Presets. BOOM LOGGER  
<LOAD> ANG A2B LOCK RADIUS TIP RF

⇒ Proceed to next page

Change Cal or Presets.      **BOOM**    **LOGGER**  
<LOAD>    ANG    A2B    LOCK    RADIUS    TIP    RF

- ⇒ display will appear as above, continue by pushing the **MODE** and **↓** buttons once.
- ⇒ display will appear as follow:

<SET ZERO>    SET MIN    TARE    RESTORE  
SET SPAN    SET MAX    DISABLE



Calibrate    LOAD MAIN    ZERO:    000 lb  
Accept by Mode↓, Change by ↑↓ buttons.

- ⇒ continue by pushing the **MODE** and **↓** buttons. Display will appear as above:

Calibrate    LOAD MAIN    ZERO:    1,200 lb  
Accept by Mode↓, Change by ↑↓ buttons.

- ⇒ with **no load on the hook** adjust the **ZERO SETTING** by pushing the **↑** or **↓** buttons until the number displayed to the right of **ZERO:** is as close to your **known weight of hook block or the headache ball**. For example a 1,200 pound block would be displayed as above:

**IMPORTANT CALIBRATION / WEIGHT ADJUSTMENT INFORMATION:**

Please note:  
In the system calibration modes the actual weight (resolution in pounds) changed by a single push of an **↑** or **↓** button during these calibration sequences is in 100 pound increments up to 16 parts-of-line.  
If you require 17+ parts-of-line the resolution will begin with 100 pounds increments of change for each push of the button. The resolution will then change to 200 pound increments for every push of the **↑** or **↓** button during the calibration sequences.

⇒ **Continued on next page**

⇒ with below left display still on the display screen, push the **MODE** and **↓** buttons to save. After the saving screen the display will return to appear as follows below right:

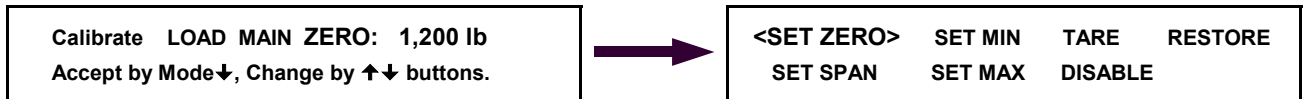

⇒ next pick up a known certified weight (see top of page 30 for definition and examples)  
 ⇒ with the known weight in the air **push ↓ button** once until **<SET SPAN>** is selected as displayed below:

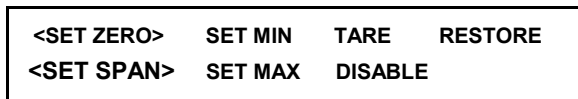

⇒ with the above display screen above continue by pushing the **MODE** and **↓** buttons. Display will appear as follows with an example of a known weight (40,000 lbs.) :



⇒ adjust the weight display right of **SPAN: to read the same as your known weight.** (Please read Weight Adjustment Information at the bottom of page 32 of this manual). Once you have adjusted the weight to as close to your known weight as possible, save by pushing the **MODE** and **↓** buttons. Display will return to appear as below:



⇒ press **MODE** and **↑** buttons.

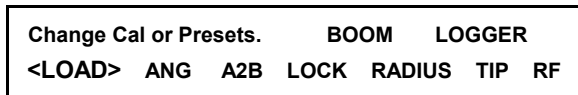

⇒ press **MODE** and **↑** buttons once again.  
 ⇒ the system will return to the **Primary Operating Screen** as below:

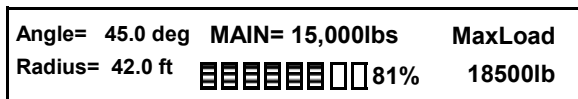

**To verify settings pick up the same known weight. If correct calibration is complete, repeat each step of the load cell calibration process with each load cell of each winch, example: main, auxiliary one, etc. If you wish to calibrate another load cell of the system, repeat these steps selecting the load cell in step 4 (Selecting correct winch line) of this sequence.**

## Angle sensor side selection instructions – for RIGHT SIDE installation only.

**PLEASE READ THIS ENTIRE SECTION OF ZERO ANGLE CALIBRATION BEFORE PROCEEDING! DO NOT POWER UP PANEL UNTIL READ AND UNDERSTOOD COMPLETELY.**

Please reference page 13 of this manual for installation of the angle sensor which must be on the crane before proceeding with these instructions.

The angle sensor can be mounted on either side of the boom however the default setting is to install it on the **LEFT SIDE** of the boom. If you determine that the right side of the boom is a more desirable location for the angle sensor, you must program the blue receiver panel for right boom operation while keeping line of sight. This section will show you how to program the panel to work with an angle sensor mounted on the **RIGHT SIDE** of the boom.

If you have mounted the angle sensor on the left side of the boom – proceed with zeroing angle calibration in the next section of this manual. If you have mounted the angle sensor on either the top or bottom of the boom, the system will not function. These steps will describe how to program the right operating side for the angle sensor.

### Angle transducer side selection

⇒ You must follow each of these steps in this sequence for angle side selection

⇒ start with the panel displaying the Primary Operating screen below:

Angle= 45.0 deg	MAIN= 15,000lbs	MaxLoad
Radius= 42.0 ft	■■■■■■■■■■ 81%	18500lb

⇒ push the **↓** button once to display your load chart information display screen below:

01: Link Belt 518 90ft boom Static
MAIN Load POL= 4 Boom Length= 90.0 ft

⇒ push and hold the **MODE** button in. While holding in the **MODE** button, push the **TEST** button once. The following display screen will appear:

Select Permission Code: 127
Accept by Mode↓, Change by ↑↓ buttons.

⇒ pressing the **↑** or **↓** buttons select **111** for permission code until display screen appears as follows:

Select Permission Code: 111
Accept by Mode↓, Change by ↑↓ buttons.

⇒ Proceed to next page >



```

Change Cal or Presets.   BOOM   LOGGER
LOAD <ANG>  A2B  LOCK  RADIUS  TIP  RF
  
```

⇒ from the above display screen, move to the next screen by pushing the **MODE** and **↓** button. The display screen will appear as follows in Figure 2G below left:

Figure 2G

```

<SET ZERO>  SET MIN  SELECT SENSOR
SELECT SIDE  SET MAX   DISABLE
  
```

Figure 2H

```

SET ZERO     SET MIN  SELECT SENSOR
<SELECT SIDE> SET MAX   DISABLE
  
```

⇒ choose **SELECT SIDE** by pushing **↓** button once until **<SELECT SIDE>** appears as above in Figure 2H.

⇒ save by pushing the **MODE** and **↓** button. Display will appear as follows:

```

Select ANGLE MAIN SIDE:  right
Accept by Mode↓, Change by ↑↓ buttons.
  
```

⇒ select either **RIGHT** or **LEFT** using the **↑** or **↓** buttons. Save by pushing the **MODE** and **↓** button. After the saving screen Display will appear as follows:

```

SET ZERO     SET MIN  SELECT SENSOR
<SELECT SIDE> SET MAX   DISABLE
  
```

⇒ press **MODE** and **↑** buttons. The system will display the screen as below:

```

Change Cal or Presets.   BOOM   LOGGER
LOAD <ANG>  A2B  LOCK  RADIUS  TIP  RF
  
```

⇒ press **MODE** and **↑** buttons once again.  
 ⇒ the system will return to the **Primary Operating Screen** as below:

```

Angle= 45.0 deg  MAIN= 15,000lbs  MaxLoad
Radius= 42.0 ft  ██████████ 81%    18500lb
  
```

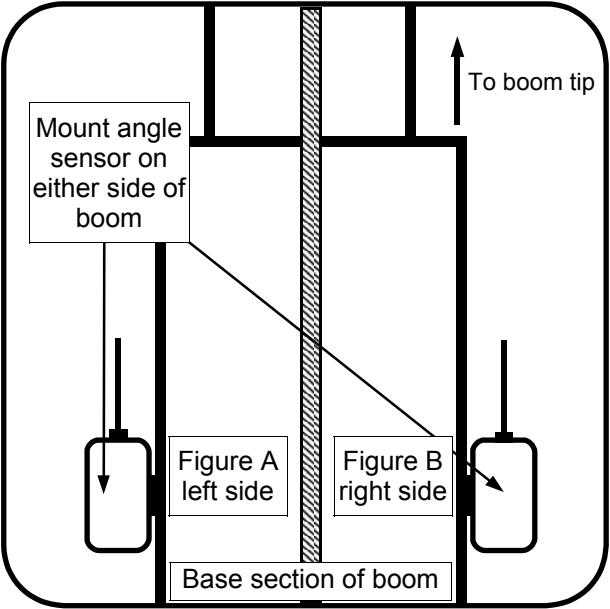

**Angle side selection is now complete.**



## ANGLE ZERO display read out instructions:

**PLEASE READ THIS ENTIRE SECTION OF ZERO ANGLE CALIBRATION BEFORE PROCEEDING! DO NOT POWER UP PANEL UNTIL READ AND UNDERSTOOD COMPLETELY.**

Once the boom angle sensor is installed, you will likely need to zero the angle value in the receiver/display panel. These steps will describe how to zero the angle when your BOOM/LUFFING JIB is as close to horizontal as possible, with the angle sensor installed on the boom/luffing jib as level as possible. Please reference page 14 of this manual for installation of the angle sensor which must be on the crane before proceeding with these instructions.

## ANGLE ZERO display read out

⇒ You must follow each of these steps in this sequence to zero the angle sensor only.

### Steps to zeroing of angle display read out – angle sensor:

⇒ start with the panel displaying the Primary Operating screen below:

Angle= 45.0 deg	MAIN= 15,000lbs	MaxLoad
Radius= 42.0 ft	■■■■■■■■■■ 81%	18500lb

⇒ push the **↓** button once to display your load chart information display screen below:

01: Link Belt 518 90ft boom Static
MAIN Load POL= 4 Boom Length= 90.0 ft

⇒ push and hold the **MODE** button in. While holding in the **MODE** button, push the **TEST** button once. The following display screen will appear:

Select Permission Code: 127
Accept by Mode↓, Change by ↑↓ buttons.

⇒ release the two buttons. Pressing the **↑** or **↓** buttons select **111** for permission code until display screen appears as follows:

Select Permission Code: 111
Accept by Mode↓, Change by ↑↓ buttons.

⇒ save by pushing the **MODE** and **↓** button.

⇒ Continued on next page >



Change Cal or Presets.	BOOM	LOGGER
LOAD <ANG>	A2B	LOCK RADIUS TIP RF

- ⇒ from the above display screen, move to the next screen by pushing the **MODE** and **↓** button.
- ⇒ the display screen will appear as follows:

<SET ZERO>	SET MIN	SELECT SENSOR
SELECT SIDE	SET MAX	DISABLE

- ⇒ move to next screen by pushing the **MODE** and **↓** button. Display will appear as follows:

Calibrate	ANGLE MAIN ZERO:	20.0 deg
Accept by Mode↓, Change by ↑↓ buttons.		

- ⇒ your boom should be pre-positioned to zero degrees using a carpenters level if possible.
- ⇒ once you have positioned the boom to as close to zero degrees as possible, press the **↑** or **↓** buttons until the readout to the right of ANGLE MAIN ZERO: displays the actual boom angle, example below:

Calibrate	ANGLE MAIN ZERO:	00.0 deg
Accept by Mode↓, Change by ↑↓ buttons.		

- ⇒ save by pushing the **MODE** and **↓** button. After the saving screen the Display will appear as follows:

<SET ZERO>	SET MIN	SELECT SENSOR
SELECT SIDE	SET MAX	DISABLE

- ⇒ press **MODE** and **↑** buttons. The system will display the screen as below:

Change Cal or Presets.	BOOM	LOGGER
LOAD <ANG>	A2B	LOCK RADIUS TIP RF

- ⇒ press **MODE** and **↑** buttons once again.
- ⇒ the system will return to the **Primary Operating Screen** as below:

Angle=	45.0 deg	MAIN=	15,000lbs	MaxLoad
Radius=	42.0 ft		81%	18500lb

**Zeroing of angle is now complete. If you wish to select another angle sensor to zero, such as an angle sensor on the jib of your crane, proceed to the next page.**

## Angle sensor selection instructions:

**PLEASE READ THIS ENTIRE SECTION OF ANGLE SENSOR SELECTION BEFORE PROCEEDING! DO NOT POWER UP PANEL UNTIL READ AND UNDERSTOOD COMPLETELY.**

If your system utilizes two angle sensors, one on the main boom and another on the luffing jib for example, you will need to select the correct angle sensor prior to zeroing the angle calibration as described in the previous section. These steps will describe how to select the angle sensor prior to zeroing the angle display.

## Angle sensor selection

⇒ You must follow each of these steps in the sequence following to select angle sensors.

### Steps to selecting angle sensors:

⇒ start with the panel displaying the Primary Operating screen below:

Angle= 45.0 deg	MAIN= 15,000lbs	MaxLoad
Radius= 42.0 ft	■■■■■■■■■■ 81%	18500lb

⇒ push the **↓** button once to display your load chart information display screen below:

01: Link Belt 518 90ft boom Static
MAIN Load POL= 4 Boom Length= 90.0 ft

⇒ push and hold the **MODE** button in. While holding in the **MODE** button, push the **TEST** button once. The following display screen will appear:

Select Permission Code: 127
Accept by Mode↓, Change by ↑↓ buttons.

⇒ release the two buttons. Pressing the **↑** or **↓** buttons select **111** for permission code until display screen appears as follows:

Select Permission Code: 111
Accept by Mode↓, Change by ↑↓ buttons.

⇒ save by pushing the **MODE** and **↓** button.

⇒ Continued on next page >



Change Cal or Presets.	BOOM	LOGGER
LOAD <ANG>	A2B	LOCK RADIUS TIP RF

⇒ from the above display screen, move to the next screen by pushing the **MODE** and **↓** button. The display screen will appear as follows below left:

<SET ZERO>	SET MIN	SELECT SENSOR
SELECT SIDE	SET MAX	DISABLE



SET ZERO	SET MIN	<SELECT SENSOR>
SELECT SIDE	SET MAX	DISABLE

⇒ choose **SELECT SENSOR** by pushing **↑** button twice until **<SELECT SENSOR>** appears as above in Figure 2H.

⇒ save by pushing the **MODE** and **↓** button. Display will appear as follows:

Select Angle Sensor:	ANGLE JIB
Accept by Mode↓, Change by ↑↓ buttons.	

⇒ if necessary press the **↓** button until **ANGLE JIB** appears as above in the display.

⇒ save by pushing the **MODE** and **↓** button. Display will appear as follows:

SET ZERO	SET MIN	<SELECT SENSOR>
SELECT SIDE	SET MAX	DISABLE

⇒ press **MODE** and **↑** buttons. The system will display the screen as below:

Change Cal or Presets.	BOOM	LOGGER
LOAD <ANG>	A2B	LOCK RADIUS TIP RF

⇒ press **MODE** and **↑** buttons once again.

⇒ the system will return to the **Primary Operating Screen** as below:

Angle= 45.0 deg	MAIN= 15,000lbs	MaxLoad
Radius= 42.0 ft	 81%	18500lb

**Selection of ANGLE SENSOR is now complete.**

## **Section Four**

**The load cell, anti-2-block switch, angle transducer and panel  
must all be installed  
before proceeding past this point of the manual.**

**This section provides information for:**

- ⇒ **Selecting LOAD WINCH LINE**
- ⇒ **Setting LOAD MINIMUM alarms**
- ⇒ **Setting LOAD MAXIMUM alarms**
- ⇒ **To ENABLE TARE OUT function**
- ⇒ **To DISABLE TARE OUT function**
- ⇒ **Setting ANGLE MINIMUM alarms**
- ⇒ **Setting ANGLE MAXIMUM alarms**
- ⇒ **Setting RADIUS MINIMUM alarms**
- ⇒ **Setting RADIUS MAXIMUM alarms**
- ⇒ **Setting TIP HEIGHT MINIMUM alarms**
- ⇒ **Setting TIP HEIGHT MAXIMUM alarms**

NOTE: Your system must be enabled to set and change alarms. If you are asked for a permissions code at any step in this sequence – your system was ordered with this function locked out. Simply call the service department at 1-888-562-3222 for information on how to unlock the system.

## Selecting winch line

The Cranesmart System allows the operator to specify minimum and maximum operating limits for the crane's load. Before you enter the minimum or maximum alarm preset information, you will need to choose which winch line, if you have a multi-line Cranesmart System. Once you have set the MIN/MAX alarms for your Main winch, you should also set the MIN/MAX alarms for your other winch lines, either Auxiliary 1 and/or Auxiliary 2. If any of the preset maximum limits are exceeded or the minimum limits are broken the Cranesmart System will alarm and activate the crane's shut off system. (if installed) To select the correct winch line follow these simple steps:

### Selecting winch line:

⇒ begin in **Primary Operating Display**. From the **Primary Operating Display** the display will appear as follows:

Angle= 45.0 deg	MAIN= 15,000lbs	MaxLoad
Radius= 42.0 ft	▣▣▣▣▣▣▣▣ 81%	18500lb

⇒ push the **↓ button**. Display will go to display as follows:

01: Link Belt 518 90ft boom Static
MAIN Load POL= 4 Boom Length= 90.0 ft

⇒ push the **TEST button**. Display will appear as follows:

MAIN Winch is selected.
Accept by Mode↓, Change by ↑↓ buttons.

⇒ push the **MODE and ↓ buttons**. Display will appear as follows:

MAIN Winch is selected.	→	AUX1 Winch is selected.
Accept by Mode↓, Change by ↑↓ buttons.		Accept by Mode↓, Change by ↑↓ buttons.

⇒ to **Select a Winch Line for Load Alarm Programming** choose the correct winch line from the above display using the **↑ or ↓ buttons**.

⇒ **once the correct winch line is displayed, continue by pushing the MODE and ↓ buttons**. You will see the **SAVING DISPLAY** screen then the display will appear as follows:

Parts Of Line: 1	→	Angle= 45.0 deg	MAIN= 15,000lbs	MaxLoad
Accept by Mode↓, Change by ↑↓ buttons.		Radius= 42.0 ft	▣▣▣▣▣▣▣▣ 81%	18500lb

⇒ push the **MODE and ↓ buttons**.

⇒ display will return to the **Primary Operating Display**.

**Selecting winch line is now complete.** You may now continue with programming the **Minimum and Maximum load alarms** by following the detailed steps on the following pages.



## Setting MINIMUM alarms for LOAD

**PLEASE READ THIS ENTIRE SECTION OF SETTING MIN/MAX ALARMS BEFORE PROCEEDING! DO NOT POWER UP PANEL UNTIL READ AND UNDERSTOOD COMPLETELY.**

NOTE: Your system must be enabled to set and change alarms. If you are asked for a permissions code at any step in this sequence – your system was ordered with this function locked out. Simply call the service department at 1-888-562-3222 for information on how to unlock the system.

The Cranesmart System allows the operator to specify minimum operating limits for the crane's load. If the preset minimum limit is exceeded the Cranesmart System will alarm and activate the crane's shut off system. (if installed) To set the **minimum load alarm** follow these simple steps:

### Setting Minimum Alarms for LOAD TO SET MINIMUM ALARM:

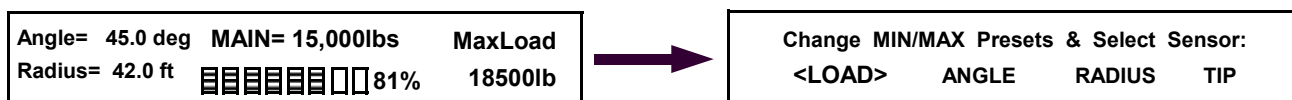

- ⇒ from the above left Primary Operating Display, push the **MODE** and **↓** buttons. Display will appear as above right.
- ⇒ as this sequence describes setting the **MINIMUM ALARM** for the **LOAD**, continue by simply pushing the **MODE** and **↓** buttons. Display will appear as below left:

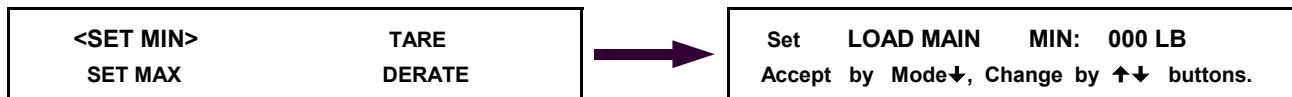

- ⇒ to move to the **MINIMUM LOAD ALARM** display screen, continue by simply pushing the **MODE** and **↓** buttons. Display will appear as above right:



- ⇒ press the **↑** or **↓** buttons until the readout to the right of **LOAD MAIN MIN:** displays the minimum load value you wish, example: a 400 pound minimum preset above left.
- ⇒ save by pushing the **MODE** and **↓** button. Display will appear as above right.
- ⇒ press **MODE** and **↑** buttons. The system will display the screen as below left:

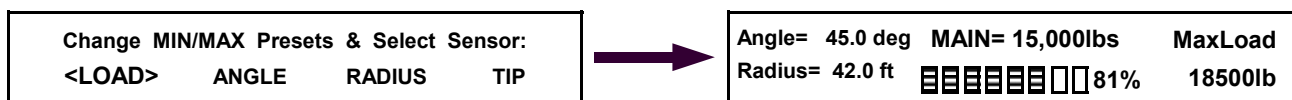

- ⇒ press **MODE** and **↑** buttons once again.
  - ⇒ the system will return to the **Primary Operating Screen**.
- Setting the minimum load alarm is now complete. If you have an Auxiliary load cell that you wish to set the minimum load alarm on, simply repeat these steps selecting winch Aux1 in selecting winch line instructions at the beginning of this section.**

## Setting MAXIMUM alarms for LOAD

**PLEASE READ THIS ENTIRE SECTION OF SETTING MIN/MAX ALARMS BEFORE PROCEEDING! DO NOT POWER UP PANEL UNTIL READ AND UNDERSTOOD COMPLETELY.**

NOTE: Your system must be enabled to set and change alarms. If you are asked for a permissions code at any step in this sequence – your system was ordered with this function locked out. Simply call the service department at 1-888-562-3222 for information on how to unlock the system.

The Cranesmart System allows the operator to specify maximum operating limits for the crane's load. If the preset maximum limit is exceeded the Cranesmart System will alarm and activate the crane's shut off system. (if installed) To set the **maximum load alarm** follow these simple steps:

### Setting Maximum Alarms for LOAD TO SET MAXIMUM ALARM:

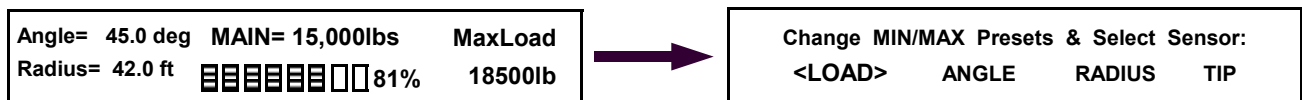

⇒ from the above left Primary Operating Display, push the **MODE** and **↓** buttons. Display will appear as above right.

⇒ as this sequence describes setting the **MAXIMUM ALARM** for the **LOAD**, continue by simply pushing the **MODE** and **↓** buttons. Display will appear as below left:

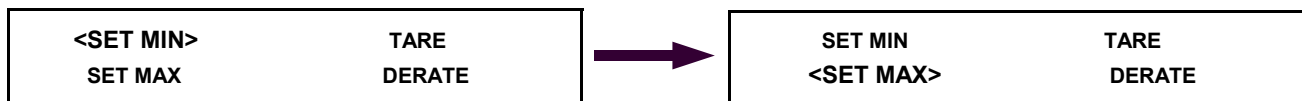

⇒ continue by simply pushing the **↓** button once to select **<SET MAX>** as above right. Accept by pressing the **MODE** and **↓** buttons once. Display will appear as below left.

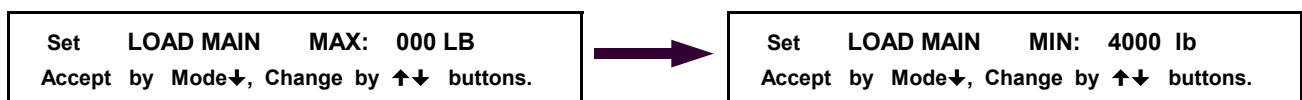

⇒ press the **↑** or **↓** buttons until the readout to the right of **LOAD MAIN MAX:** displays the maximum load value you wish, example: a 4000 pound maximum preset above left.

⇒ save by pushing the **MODE** and **↓** button. The saving screen will appear briefly.

⇒ press and while holding the **MODE** button in press the **↑** button twice.

⇒ the system will return to the **Primary Operating Screen**.

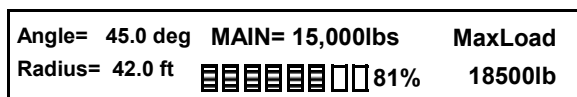

Setting the maximum load alarm is now complete. If you have an Auxiliary load cell that you wish to set the maximum load alarm on, simply repeat these steps selecting winch Aux1 in selecting winch line instructions at the beginning of this section.

## Enabling LOAD TARE OUT function

The Cranesmart System has a Tare function which will allow the crane operator to zero out the weight of the hook block or headache ball. Once this is done, only the load below the hook will be displayed as the actual weight on the receiver/display panel.

**Please note that it is a safer practice to keep the weight of the cranes rigging included in the displayed weight as the load charts of the crane do not subtract the weight of such rigging and therefore it should be included for safe operating parameters.**

### To enable load tare out setting

**First you must choose the winch line you wish to set the TARE on:**

#### Selecting winch line:

⇒ begin in **Primary Operating Display**. From the **Primary Operating Display** the display will appear as follows:

Angle= 45.0 deg	MAIN= 15,000lbs	MaxLoad
Radius= 42.0 ft	■■■■■■■■■■ 81%	18500lb

⇒ push the **↓** button. Display will appear as follows:

01: Link Belt 518 90ft boom Static
MAIN Load POL= 4 Boom Length= 90.0 ft

⇒ push the **TEST** button. Display will appear as follows:

MAIN Winch is selected.
Accept by Mode↓, Change by ↑↓ buttons.

⇒ **to Select a Winch Line to TARE choose the correct winch line** from the above display using the **↑** or **↓** buttons. **Note: If your system is programmed for only one winch line, there is no option to select another.**

⇒ **once the correct winch line is displayed, continue by pushing the MODE and ↓ buttons.** You may see the **SAVING DISPLAY** screen then the display will appear as follows:

01: Link Belt 518 90ft boom Static
MAIN Load POL= 4 Boom Length= 90.0 ft



Parts Of Line: 1
Accept by Mode↓, Change by ↑↓ buttons.

⇒ push the **MODE** and **↓** buttons.

⇒ display will return to the **Primary Operating Display**.

Angle= 45.0 deg	MAIN= 15,000lbs	MaxLoad
Radius= 42.0 ft	■■■■■■■■■■ 81%	18500lb

⇒ Continued on next page >

Angle= 45.0 deg	MAIN= 15,000lbs	MaxLoad
Radius= 42.0 ft	■■■■■■■■■■ 81%	18500lb

- ⇒ while viewing the above Primary Operating Display lift up the desired weight that you wish to tare out, **the hook block or headache ball for example.**
- ⇒ **with the weight in the air**, continue by simply pushing the **MODE** and **↓** buttons. Display will appear as follows:

Change MIN/MAX Presets & Select Sensor:			
<LOAD>	ANGLE	RADIUS	TIP

- ⇒ continue by simply pushing the **MODE** and **↓** buttons. Display will appear as follows:

<SET MIN>	TARE	SET MIN	<TARE>
SET MAX	DERATE	SET MAX	DERATE

- ⇒ press the **↓** button twice to select **<TARE>** as in above left display.
- ⇒ push the **MODE** and **↓** buttons.
- ⇒ display will return to the Primary Operating Display with the letter **T** just right of the bar graph as illustrated below:

Angle= 45.0 deg	MAIN= 15,000lbs	MaxLoad
Radius= 42.0 ft	■■■■■■■■■■ T 81%	18500lb

Setting the TARE OUT function is now complete. If you have an Auxiliary load cell that you wish to tare out, simply repeat these steps selecting winch Aux 1 in step 5 of this procedure.

While the system remains in the TARE mode with the letter T to the right of the bar graph on the primary operating display, any weight lifted by the crane will be the weight of the object below the hook only.

### Disabling of TARE OUT function

#### To disable TARE OUT function:

- ⇒ either increase or decrease the boom angle by +/- three degrees or;

Disabling of TARE OUT function is now complete.

## Setting MINIMUM alarms for ANGLE

**PLEASE READ THIS ENTIRE SECTION OF SETTING MIN/MAX ALARMS BEFORE PROCEEDING! DO NOT POWER UP PANEL UNTIL READ AND UNDERSTOOD COMPLETELY.**

The Cranesmart System allows the operator to specify minimum operating limits for the crane's angle. If the preset minimum limit is exceeded the Cranesmart System will alarm and activate the crane's shut off system. (if installed) To set the **minimum angle alarm** follow these simple steps:

### Setting Minimum Alarms for ANGLE TO SET MINIMUM ALARM:

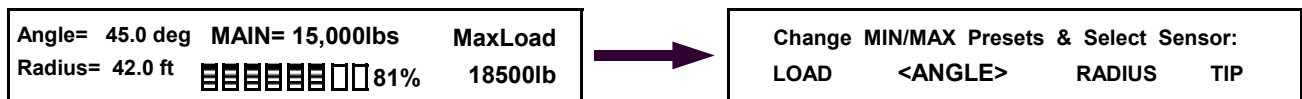

- ⇒ from the above left Primary Operating Display - push the **MODE** and **↓** buttons.
- ⇒ then push **↓** button once only. Display will appear as above right with **<ANGLE>** selected.
- ⇒ as this sequence describes setting the **MINIMUM ALARM** for the **ANGLE**, continue by simply pushing the **MODE** and **↓** buttons. Display will appear as below left:

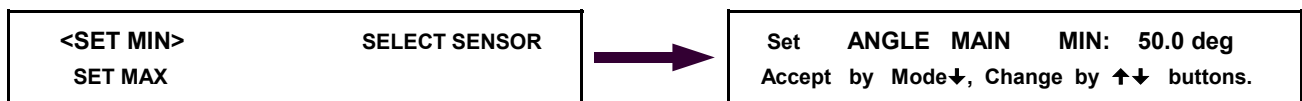

- ⇒ to move to the **MINIMUM ANGLE ALARM display screen**, continue by simply pushing the **MODE** and **↓** buttons. Display will appear as above right:



- ⇒ press the **↑** or **↓** buttons until the readout to the right of **ANGLE MAIN MIN:** displays the minimum angle value you wish, example: 10 degree minimum preset above left.
- ⇒ save by pushing the **MODE** and **↓** button. Display will now appear as above right.
- ⇒ press and while holding the **MODE** button in press the **↑** button twice.
- ⇒ the system will return to the **Primary Operating Screen** below.

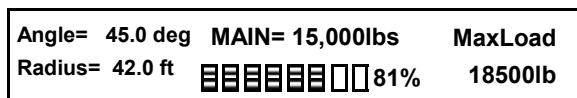

Setting the minimum angle alarm is now complete. If you have an Auxiliary or Jib angle sensor that you wish to set the minimum angle alarm on, simply repeat these steps after selecting the correct angle sensor in angle sensor selection found in section three of this manual.

## Setting MAXIMUM alarms for ANGLE

**PLEASE READ THIS ENTIRE SECTION OF SETTING MIN/MAX ALARMS BEFORE PROCEEDING! DO NOT POWER UP PANEL UNTIL READ AND UNDERSTOOD COMPLETELY.**

The Cranesmart System allows the operator to specify maximum operating limits for the crane's angle. If the preset maximum limit is exceeded the Cranesmart System will alarm and activate the crane's shut off system. (if installed) To set the **maximum angle alarm** follow these simple steps:

### Setting Maximum Alarms for ANGLE TO SET MAXIMUM ALARM:

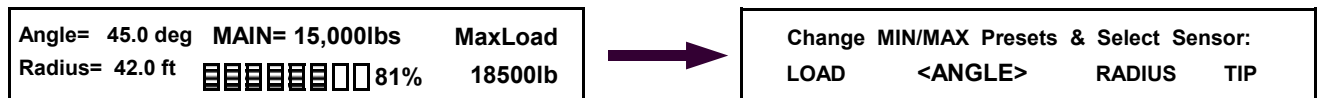

- ⇒ from the above Primary Operating Display – push the **MODE** and **↓** buttons.
- ⇒ then push **↓** button once only. Display will appear as above right with **<ANGLE>** selected.
- ⇒ as this sequence describes setting the **MAXIMUM ALARM** for the **ANGLE**, continue by simply pushing the **MODE** and **↓** buttons once
- ⇒ then push **↓** button once only. Display will appear as below left:

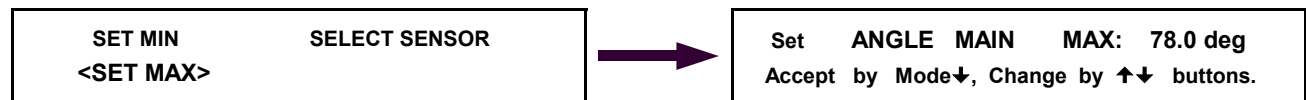

- ⇒ to move to the **MAXIMUM ANGLE ALARM display screen**, continue by simply pushing the **MODE** and **↓** buttons. Display will appear as above right:

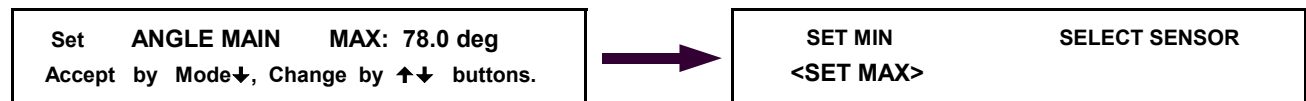

- ⇒ press the **↑** or **↓** buttons until the readout to the right of **ANGLE MAIN MAX:** displays the maximum angle value you wish, example: 78 degree maximum preset above left.
- ⇒ save by pushing the **MODE** and **↓** button.
- ⇒ press and while holding the **MODE** button in press the **↑** button twice.
- ⇒ the system will return to the **Primary Operating Screen** below.

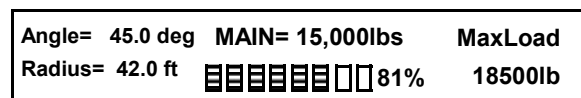

Setting the maximum angle alarm is now complete. If you have an Auxiliary or Jib angle sensor that you wish to set the maximum angle alarm on, simply repeat these steps after selecting the correct angle sensor in angle sensor selection found in section three of this manual.

## Setting MINIMUM alarms for RADIUS

**PLEASE READ THIS ENTIRE SECTION OF SETTING MIN/MAX ALARMS BEFORE PROCEEDING! DO NOT POWER UP PANEL UNTIL READ AND UNDERSTOOD COMPLETELY.**

The Cranesmart System allows the operator to specify minimum operating limits for the crane's radius. If the preset minimum limits are exceeded the Cranesmart System will alarm and activate the crane's shut off system. (if installed) To set the **minimum radius alarm** follow these simple steps:

### Setting Minimum Alarms for RADIUS TO SET MINIMUM ALARM:

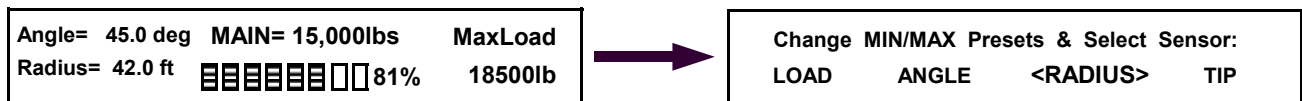

- ⇒ from the above Primary Operating Display - push the **MODE** and **↓** buttons.
- ⇒ then push **↓** button twice. Display will appear as above with **<RADIUS>** selected.
- ⇒ as this sequence describes setting the **MINIMUM ALARM** for the **RADIUS**, continue by simply pushing the **MODE** and **↓** buttons. Display will appear as below left:

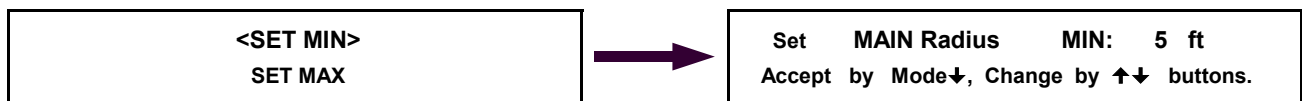

- ⇒ to move to the **MINIMUM RADIUS ALARM display screen**, continue by simply pushing the **MODE** and **↓** buttons. Display will appear as above right in Figure 2L:



- ⇒ press the **↑** or **↓** buttons until the readout to the right of **MAIN RADIUS MIN:** displays the minimum radius value you wish, example: 5 foot minimum preset above left.
- ⇒ save by pushing the **MODE** and **↓** button. Display will appear as above right.
- ⇒ press and while holding the **MODE** button in press the **↑** button twice.
- ⇒ the system will return to the **Primary Operating Screen** below.

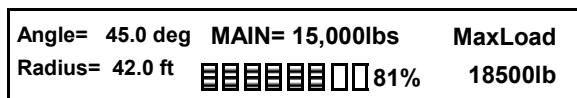

Setting the minimum radius alarm is now complete.

## Setting MAXIMUM alarms for RADIUS

**PLEASE READ THIS ENTIRE SECTION OF SETTING MIN/MAX ALARMS BEFORE PROCEEDING! DO NOT POWER UP PANEL UNTIL READ AND UNDERSTOOD COMPLETELY.**

The Cranesmart System allows the operator to specify maximum operating limits for the crane's radius. If the preset maximum limits are exceeded the Cranesmart System will alarm and activate the crane's shut off system. (if installed) To set the **maximum radius alarm** follow these simple steps:

### Setting Maximum Alarms for RADIUS TO SET MAXIMUM ALARM:

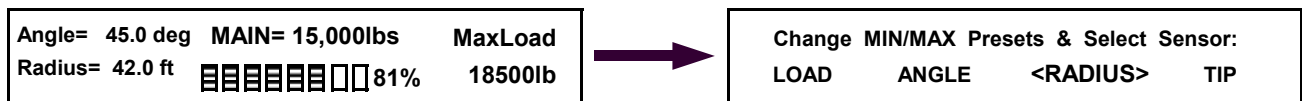

- ⇒ from the above Primary Operating Display Figure 2A, push the **MODE and ↓ buttons**.
- ⇒ then push **↓ button twice**. Display will appear as above with **<RADIUS>** selected.
- ⇒ as this sequence describes setting the **MAXIMUM ALARM** for the **RADIUS**, continue by simply pushing the **MODE and ↓ buttons**.
- ⇒ then push **↓ button once only**. Display will appear as below left:

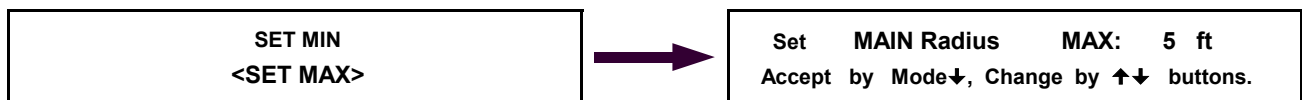

- ⇒ to move to the **MAXIMUM RADIUS ALARM display screen**, continue by simply pushing the **MODE and ↓ buttons**. Display will appear as above right:

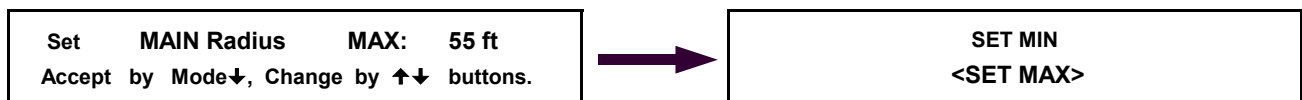

- ⇒ press the **↑ or ↓ buttons** until the readout to the right of **MAIN RADIUS MAX:** displays the maximum radius value you wish, example: 55 foot maximum preset above left.
- ⇒ save by pushing the **MODE and ↓ button**. Display will appear as above right.
- ⇒ press and while holding the **MODE button in press the ↑ button twice**.
- ⇒ the system will return to the **Primary Operating Screen** below.

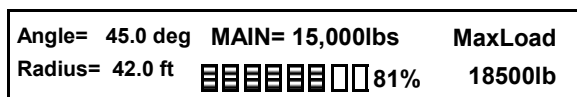

Setting the maximum radius alarm is now complete.



## Setting MINIMUM alarms for TIP HEIGHT

**PLEASE READ THIS ENTIRE SECTION OF SETTING MIN/MAX ALARMS BEFORE PROCEEDING! DO NOT POWER UP PANEL UNTIL READ AND UNDERSTOOD COMPLETELY.**

The Cranesmart System allows the operator to specify minimum operating limits for the crane's tip height. If the preset minimum limits are exceeded the Crane Smart™ System will alarm and activate the crane's shut off system. (if installed) To set the **minimum tip height alarm** follow these simple steps:

### Setting Minimum Alarms for TIP HEIGHT TO SET MINIMUM ALARM:

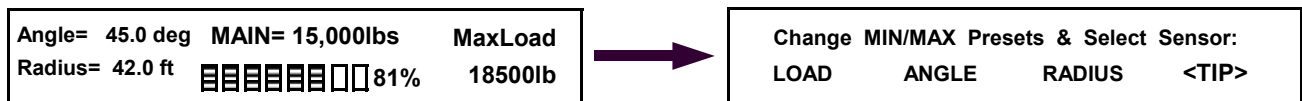

- ⇒ from the above Primary Operating Display - push the **MODE** and **↓** buttons.
- ⇒ then push **↓** button three times. Display will appear as above with **<TIP>** selected.
- ⇒ as this sequence describes setting the **MINIMUM ALARM** for the **TIP HEIGHT**, continue by simply pushing the **MODE** and **↓** buttons. Display will appear as below left:

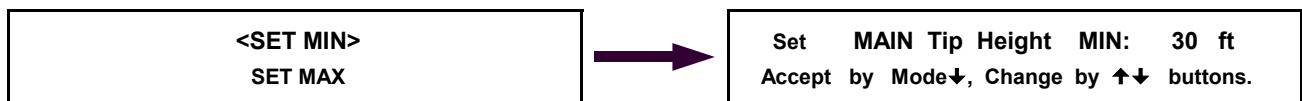

- ⇒ to move to the **MINIMUM TIP HEIGHT ALARM display screen**, continue by simply pushing the **MODE** and **↓** buttons. Display will appear as above right:



- ⇒ press the **↑** or **↓** buttons until the readout to the right of **MAIN Tip Height MIN:** displays the minimum tip height value you wish, example: 30 foot minimum preset above left.
- ⇒ save by pushing the **MODE** and **↓** button. Display will appear as above right.
- ⇒ press and while holding the **MODE** button in press the **↑** button twice.
- ⇒ the system will return to the **Primary Operating Screen** below.

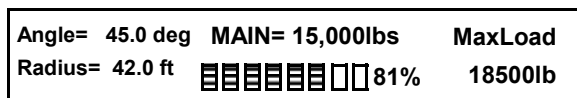

Setting the minimum tip height alarm is now complete.

## Setting MAXIMUM alarms for TIP HEIGHT

**PLEASE READ THIS ENTIRE SECTION OF SETTING MIN/MAX ALARMS BEFORE PROCEEDING! DO NOT POWER UP PANEL UNTIL READ AND UNDERSTOOD COMPLETELY.**

The Cranesmart System allows the operator to specify maximum operating limits for the crane's tip height. If the preset maximum limits are exceeded the Cranesmart System will alarm and activate the crane's shut off system. (if installed) To set the **maximum tip height alarm** follow these simple steps:

### Setting Maximum Alarms for TIP HEIGHT TO SET MAXIMUM ALARM:

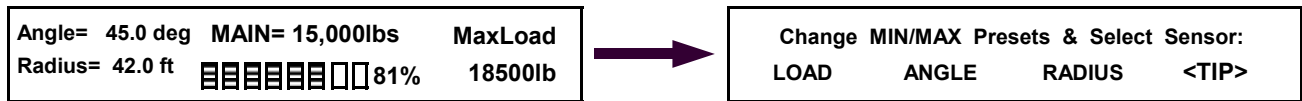

- ⇒ from the above Primary Operating Display - push the **MODE** and **↓** buttons.
- ⇒ then push **↓** button three times. Display will appear as above with **<TIP>** selected.
- ⇒ as this sequence describes setting the **MAXIMUM ALARM** for the **TIP HEIGHT**, continue by simply pushing the **MODE** and **↓** buttons.
- ⇒ then push **↓** button once only. Display will appear as below left:

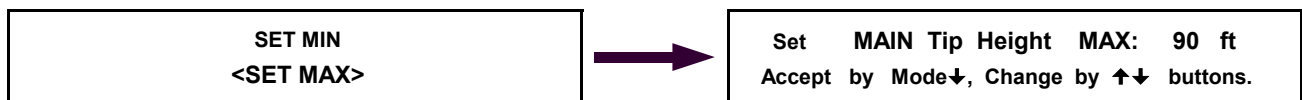

- ⇒ to move to the **MAXIMUM TIP HEIGHT ALARM display screen**, continue by simply pushing the **MODE** and **↓** buttons. Display will appear as above right in Figure 2L:

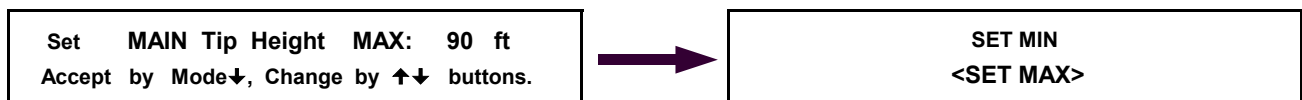

- ⇒ press the **↑** or **↓** buttons until the readout to the right of **MAIN tip Height MAX:** displays the maximum tip height value you wish, example: 90 foot maximum preset above left in Figure 2M.
- ⇒ save by pushing the **MODE** and **↓** button. Display will appear as above right.
- ⇒ press and while holding the **MODE** button in press the **↑** button twice.
- ⇒ the system will return to the **Primary Operating Screen** below.

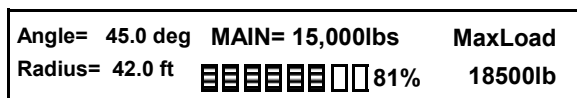

Setting the maximum tip height alarm is now complete.

## Section Five

This section provides information for:

- ⇒ Troubleshooting the Cranesmart System
- ⇒ Technical Specifications
- ⇒ Warranty

### **Emergency shut-off by-pass plug – for use on system where NO ALARM HUB IS USED**

When shut offs are wired from the receiver panel and the Cranesmart system is overcome by user damage, extremely high RF, or system malfunction, remove the plug with the yellow tag found in your panel mounting assembly.

Next remove power cable from the panel by twisting the coupling 1/2 turn counter-clockwise and pull away from the panel. Insert this by-pass plug into the end of the power cable – **not the panel** - and turn plug 1/2 turn clockwise.

This will over-ride the shut off power signal enabling the continued uninterrupted use of your crane. Please note that you will not have anti-2-block protection, once the power cable is removed from the blue receiver panel. Call the service department of The Load & A-2-B Company for further assistance.

## Troubleshooting guide

**Please do not attempt to open any components of this system.  
Read this section completely and then contact  
The Load & A-2-B Company service department at 1-888-562-3222.**

Problem description	Possible solution
1. Panel does not power up	A. Power cable may be disconnected. B. Verify that there is +12VDC going to the panel. C. Check power cable for damage. (cuts, nicks, etc.)
2. Panel powers up but does not run through the full start up sequence e.g. Lights burnt out, missing numbers, etc.	A. Verify that there is +12VDC going to the panel. B. Power the panel directly with +12VDC from the cranes battery bypassing any fuse panels and connections or on a separate 12 volt battery to ensure that it is not a crane power problem. C. Call the service department @ 1-888-562-3222.
3. Panel gets extremely hot to the touch	A. If the panel is installed in a cab remove the black dust cover and improve the air circulation around the panel.
4. Battery warning light is on	A. Battery needs to be replaced. Please refer to the <b>Battery Replacement</b> section of this manual.
5. System warning light is flashing	A. Loss of communication with load cell, anti-2-block switch or angle sensor. Refer to the <b>No Communication</b> section of this troubleshooting guide. B. Interference from other radio frequency sources in the area. (e.g. radio towers, high power TV antennae, satellite transmissions, etc.)
6. Display always shows the same weight or stuck on same weight even after turning the power on and off	A. Loss of communication with load cell, anti-2-block switch or angle sensor. The panel will display the last weight picked if communication is lost and it will look like the weight is stuck. Refer to the <b>No Communication</b> section of this troubleshooting guide.
7. Display is slow to update weight changes	A. Intermittent communication with load cell, anti-2-block switch or angle sensor. Refer to the <b>No Communication</b> section of this troubleshooting guide. B. Interference from other radio frequency sources in the area. (e.g. radio towers, high power TV antennae, satellite transmissions, etc.)
8. Fluctuating weights	Boom & load need to be stabilized. Try the following steps if you are still having problems; A. Raise the load as high as possible and stop until the motion of the load is minimized. Note if the fluctuation on the readout stops or is reduced. B. Lower the load & release. The readout should go back to indicating the block weight. C. If fluctuation is reduced in step <b>A</b> and the readout returns to the block weight in step <b>B</b> , the sheaves on the rigging may require cleaning and lubrication. If fluctuation is not reduced in step <b>A</b> or readout does not return to block weight in step <b>B</b> , contact the service department of The Load & A-2-B Company.

**Error message: Load Chart Exceeded, Reduce Load Moment**

**Action: Reduce weight of lift or select correct parts-of-line as per load charts**

## No communication between transmitters and blue receiver panel

If you have a suspected communication problem between the transmitters (load cell, A2B switch or angle transducer) and the receiver panel, please use the following steps in troubleshooting.

Problem description	Possible solution
1. Possible Installation Problem	<ul style="list-style-type: none"> <li>A. Thoroughly review the <b>Installation Procedures</b> at the front of this manual</li> <li>B. Verify that there is +12VDC going to the panel.</li> <li>C. Power the panel directly with +12VDC from the cranes battery by-passing any fuse panels and connections or on a separate 12 volt battery to assure that it is not a crane power problem.</li> <li>D. You should have a direct line of sight between the panel and the cell. If the load cell is dead ended up inside the boom, this may interfere with the radio signal.</li> <li>E. If your boom length is over 200 feet the display panel may need to have an external metal whip antenna.</li> </ul>
2. Possible Antenna Problem	<ul style="list-style-type: none"> <li>A. Verify that you have the right antenna for the particular installation set up. If you are not sure, please call 1-888-562-3222.</li> <li>B. Check the antenna connectors for signs of corrosion, dirt and moisture. Clean if necessary.</li> <li>C. For the 10" panel mount antenna:               <ul style="list-style-type: none"> <li>a. Panel should be mounted so that the antenna is free from any and all metal.</li> <li>b. The antenna should not be touching any glass or metal.</li> <li>c. Make sure the antenna is not damaged.</li> </ul> </li> <li>D. For both types of external antenna (metal whip and rubber whip):               <ul style="list-style-type: none"> <li>a. Make sure the antenna or the cable is not damaged.</li> <li>b. The antenna should be free of any metal and there should be a good line of sight to the load cell.</li> <li>c. Never cut the length or otherwise modify the antenna without contacting the service department at 1-888-562-3222.</li> </ul> </li> </ul>
3. Possible Dead Battery	<ul style="list-style-type: none"> <li>A. <b>Please call our service department at 1-888-562-3222 before attempting to test or replace a battery.</b></li> <li>B. The battery pack can be tested with a multi-meter and should read between 6.6 VDC and 7.3 VDC. The batteries have internal fuses so care must be taken not to short them out while testing.</li> <li>C. A 9 volt battery can be installed in the load cell to verify operation of the system and can be used for a short time while waiting for the replacement battery.</li> </ul>
4. Damage to load cell, anti-2-block switch or angle sensor	<ul style="list-style-type: none"> <li>A. If the load cell, anti-2-block switch or angle sensor has been damaged please call our service department immediately.</li> <li>B. If the plastic cases are mis-aligned, broken or cracked call our service department immediately.</li> <li>C. If the gasket seal has been damaged or broken it will allow moisture to damage the electronics and strain gauges. Please call the service department immediately.</li> </ul>

Important: All main components of the system, such as the load cells, anti-2-block switches, angle transducer and the blue receiver panel must be shipped together for any service work.  
Check serial numbers to ensure matched system components are shipped together.

# Cranesmart System Technical Component Specifications

Load cell SLP = maximum single line pull of the cranes winch in pounds

transmit range	to 1000 feet
response time	0.1 second
weight 15/25,000 SLP - (40,000 SLP)	14 pounds - (33 pounds)
length 15/25,000 SLP - (40,000 SLP)	14 inches - (22 inches)
width 15/25,000 SLP - (40,000 SLP)	5 inches by 5 inches - (5 inches by 5½ inches)
antenna	inner coil
operating temp in °F	-40 to 122 °F (-40 to 50 °C)
battery	lithium ion
battery life	two years
FCC compliance ID*	NFBLAB777

## Angle sensor

response time	0.8 second
weight (with weld plate)	10 pounds
length x height	10.5 inches by 4¾ inches
width	3¾ inches
operating temperature	-40 to 122 °F (-40 to 50 °C)
battery	lithium ion
battery life	two years
FCC compliance ID*	NFBLAB939SW

## Anti-2-block switch

transmit range	to 1000 feet
response time	0.1 second
weight (marine version)	3 pounds (8 pounds)
length	5½ inches
width	4 inches by 2 inches
antenna	7 inch (rubber flexible)
weld plate	2 x 4 x 1 inches
operating temp in °F	-40 to 122 °F (-40 to 50 °C)
battery	lithium ion
FCC compliance ID*	NFBLAB939SW

## Receiver / Display panel

panel rating	designed to meet NEMA 4X rating
optional rating	available Class 1, Div 2
display type	vacuum fluorescent display
operating temperature in °F	-50 to 150 °F (-46 to 66 °C)
panel width	11½ inches
panel depth	3½ inches
panel height	6 inches with base mounting bracket
weight	4 pounds
power requirements	12 volts
antenna	stainless steel whip

## Alarm Hub Standard/Dry contact

panel rating	designed to meet NEMA 4X rating
hazardous location compliance class	available Class 1, Div 2
operating temperature in °F	-40 to 140 °F (-40 to 60°C)
panel width	8¾ inches
panel depth	3½ inches
panel height	6 inches with base mounting bracket
weight	4.3 pounds
power requirements	12 volts, 0.5 amps (plus alarm current)
communication via	RS232 cable at 9600 baud

## Laser Emitter Component

panel rating	designed to meet NEMA 4X rating
hazardous location compliance class	N/A
operating temperature in °F	-40 to 122 °F (-40 to 50°C)
panel width	14 inches
panel depth	4⅞ inches
panel height	4¾ inches
weight	17.6 pounds with mounting plate and weld plate
power requirements	12 volts, @ 1.5 amps
communication via	RS232 cable at 9600 baud

\*FCC Compliance: Please note - Changes or modifications not expressly approved by The Load & A-2-B Company Inc. for FCC compliance could void the user's authority to operate the equipment.