

TEST REPORT

Test report no.: 1-1604/16-01-03-A



Testing laboratory

CTC advanced GmbH

Untertuerkheimer Strasse 6 – 10
66117 Saarbruecken / Germany
Phone: + 49 681 5 98 - 0
Fax: + 49 681 5 98 - 9075
Internet: <http://www.ctcadvanced.com>
e-mail: mail@ctcadvanced.com

Accredited Testing Laboratory:

The testing laboratory (area of testing) is accredited according to DIN EN ISO/IEC 17025 (2005) by the Deutsche Akkreditierungsstelle GmbH (DAkkS). The accreditation is valid for the scope of testing procedures as stated in the accreditation certificate with the registration number: D-PL-12076-01-01

Applicant

ROBERT BOSCH GmbH

Daimlerstr. 6, Gebäude 107/1
71229 Leonberg / GERMANY
Phone: +49 711 811 -37855
Fax: +49 711 811 47548
Contact: Frank Ernst
e-mail: frank.ernst@de.bosch.com
Phone: +49 711 811 -37855

Manufacturer

ROBERT BOSCH GmbH
Daimlerstr. 6, Gebäude 107/1
71229 Leonberg / GERMANY

Test standard/s

47 CFR Part 95	Subpart M: 76-81 GHz Band Radar Service
RSS - Gen Issue 4	Spectrum Management and Telecommunications Radio Standards Specifications - General Requirements and Information for the Certification of Radio Apparatus
RSS-251 Issue 1	Field Disturbance Sensors in the Bands 46.7-46.9 GHz (Vehicular Radar) and 76-77 GHz (Vehicular and Airport Fixed Radar)

For further applied test standards please refer to section 3 of this test report.

Test Item

Kind of test item:	Mid-range radar sensor for corner applications
Model name:	MRR1Crn and MRR1CrnCR
FCC ID:	NF3-MRR1CRN
IC:	3887A-MRR1CRN
Frequency:	76.0 – 77.0 GHz
Antenna:	Planar patch internal antenna
Power supply:	6.5 – 19.0 V DC by battery
Temperature range:	-40°C to +90°C

This test report is electronically signed and valid without handwriting signature. For verification of the electronic signatures, the public keys can be requested at the testing laboratory.

Test report authorized:

Karsten Gerdaldy
Lab Manager
Radio Communications & EMC

Test performed:

p.o.

Benedikt Gerber
Lab Manager
Radio Communications & EMC

1 Table of contents

1	Table of contents	2
2	General information	3
2.1	Notes and disclaimer	3
2.2	Application details.....	3
3	Test standard/s and references	3
4	Test environment.....	4
5	Test item.....	4
5.1	General description.....	4
5.2	Additional information	4
6	Test laboratories sub-contracted	4
7	Description of the test setup.....	5
7.1	Shielded semi anechoic chamber.....	6
7.2	Shielded fully anechoic chamber	7
7.3	Radiated measurements > 18 GHz.....	8
8	Sequence of testing	10
8.1	Sequence of testing radiated spurious 9 kHz to 30 MHz.....	10
8.2	Sequence of testing radiated spurious 30 MHz to 1 GHz.....	11
8.3	Sequence of testing radiated spurious 1 GHz to 18 GHz	12
8.4	Sequence of testing radiated spurious above 18 GHz	13
8.5	Sequence of testing radiated spurious above 50 GHz with external mixers	14
9	Summary of measurement results	15
10	Measurement results	16
10.1	Power density.....	16
10.2	Occupied bandwidth.....	26
10.3	Field strength of emissions (band edge).....	27
10.4	Field strength of emissions (radiated spurious)	29
10.5	Frequency stability	56
11	Observations	57
12	Document history	58
13	Glossary.....	58
14	Accreditation Certificate	59

2 General information

2.1 Notes and disclaimer

The test results of this test report relate exclusively to the test item specified in this test report. CTC advanced GmbH does not assume responsibility for any conclusions and generalizations drawn from the test results with regard to other specimens or samples of the type of the equipment represented by the test item.

The test report may only be reproduced or published in full. Reproduction or publication of extracts from the report requires the prior written approval of CTC advanced GmbH.

The testing service provided by CTC advanced GmbH has been rendered under the current "General Terms and Conditions for CTC advanced GmbH".

CTC advanced GmbH will not be liable for any loss or damage resulting from false, inaccurate, inappropriate or incomplete product information provided by the customer.

Under no circumstances does the CTC advanced GmbH test report include any endorsement or warranty regarding the functionality, quality or performance of any other product or service provided.

Under no circumstances does the CTC advanced GmbH test report include or imply any product or service warranties from CTC advanced GmbH, including, without limitation, any implied warranties of merchantability, fitness for purpose, or non-infringement, all of which are expressly disclaimed by CTC advanced GmbH.

All rights and remedies regarding vendor's products and services for which CTC advanced GmbH has prepared this test report shall be provided by the party offering such products or services and not by CTC advanced GmbH. In no case this test report can be considered as a Letter of Approval.

This test report is electronically signed and valid without handwritten signature. For verification of the electronic signatures, the public keys can be requested at the testing laboratory.

This test report replaces the test report with the number 1-1604/16-01-03 and dated 2016-10-28

2.2 Application details

Date of receipt of order:	2016-08-29
Date of receipt of test item:	2016-08-22
Start of test:	2016-08-22
End of test:	2016-08-26
Person(s) present during the test:	Mr. Frank Ernst

3 Test standard/s and references

Test standard	Date	Description
47 CFR Part 95		Subpart M: 76-81 GHz Band Radar Service
RSS - Gen Issue 4	November 2014	Spectrum Management and Telecommunications Radio Standards Specifications - General Requirements and Information for the Certification of Radio Apparatus
RSS-251 Issue 1	November 2014	Field Disturbance Sensors in the Bands 46.7-46.9 GHz (Vehicular Radar) and 76-77 GHz (Vehicular and Airport Fixed Radar)
Guidance	Version	Description
ANSI C63.4-2014	-/-	American national standard for methods of measurement of radio-noise emissions from low-voltage electrical and electronic equipment in the range of 9 kHz to 40 GHz
ANSI C63.10-2013	-/-	American national standard of procedures for compliance testing of unlicensed wireless devices

4 Test environment

Temperature	: T _{nom} T _{max} T _{min}	+22 °C during room temperature tests +50 °C during high temperature tests -30 °C during low temperature tests
Relative humidity content	:	55 %
Barometric pressure	:	not relevant for this kind of testing
Power supply	: V _{nom} V _{max} V _{min}	12.75 VDC by lab power supply 19.00 V 6.50 V

5 Test item

5.1 General description

Kind of test item	:	Mid-range radar sensor for corner applications	
Type identification	:	MRR1Crn	MRR1CrnCR
HMN	:	-/-	-/-
PMN	:	BOSCH MRR1Crn	BOSCH MRR1CrnCR
HVIN	:	MRR1Crn	MRR1CrnCR
FVIN	:	-/-	-/-
HW hardware status	:	R0.1	
Frequency band	:	76.0 – 77.0 GHz	
Type of radio transmission	:	FMCW	
Use of frequency spectrum	:		
Antenna	:	Planar patch internal antenna	
Power supply	:	6.5 – 19.0 V DC by battery	
Temperature range	:	-40°C to +90°C	

5.2 Additional information

The customer declared that the radar sensors MRR1Cnr and MRR1CrnCR used for the measurement (in September 2016) are absolutely identical to the actual produced MRR1Crn and MRR1CrnCR. The content of the following annexes is defined in the QA. It may be that not all of the listed annexes are necessary for this report, thus some values in between may be missing.

Test setup- and EUT-photos are included in test report: 1-1604/16-01-01_AnnexA
 1-1604/16-01-01_AnnexB
 1-1604/16-01-01_AnnexC

Test mode: Normal operation mode

Special test software was used to change from normal operation mode to test mode (low / middle / high) as required by CFR 47 Part 15.31(c).

6 Test laboratories sub-contracted

None

7 Description of the test setup

Typically, the calibrations of the test apparatus are commissioned to and performed by an accredited calibration laboratory. The calibration intervals are determined in accordance with the DIN EN ISO/IEC 17025. In addition to the external calibrations, the laboratory executes comparison measurements with other calibrated test systems or effective verifications. Weekly chamber inspections and range calibrations are performed. Where possible, RF generating and signaling equipment as well as measuring receivers and analyzers are connected to an external high-precision 10 MHz reference (GPS-based or rubidium frequency standard).

In order to simplify the identification of the equipment used at some special tests, some items of test equipment and ancillaries can be provided with an identifier or number in the equipment list below (Lab/Item).

Agenda: Kind of Calibration

k	calibration / calibrated	EK	limited calibration
ne	not required (k, ev, izw, zw not required)	zw	cyclical maintenance (external cyclical maintenance)
ev	periodic self verification	izw	internal cyclical maintenance
Ve	long-term stability recognized	g	blocked for accredited testing
v/k!	Attention: extended calibration interval		
NK!	Attention: not calibrated	*)	next calibration ordered / currently in progress

7.1 Shielded semi anechoic chamber

The radiated measurements are performed in vertical and horizontal plane in the frequency range from 9 kHz to 1 GHz in semi-anechoic chambers. The EUT is positioned on a non-conductive support with a height of 0.80 m above a conductive ground plane that covers the whole chamber. The receiving antennas are confirmed with specifications ANSI C63. These antennas can be moved over the height range between 1.0 m and 4.0 m in order to search for maximum field strength emitted from EUT. The measurement distances between EUT and receiving antennas are indicated in the test setups for the various frequency ranges. For each measurement, the EUT is rotated in all three axes until the maximum field strength is received. The wanted and unwanted emissions are received by spectrum analyzers where the detector modes and resolution bandwidths over various frequency ranges are set according to requirement ANSI C63.

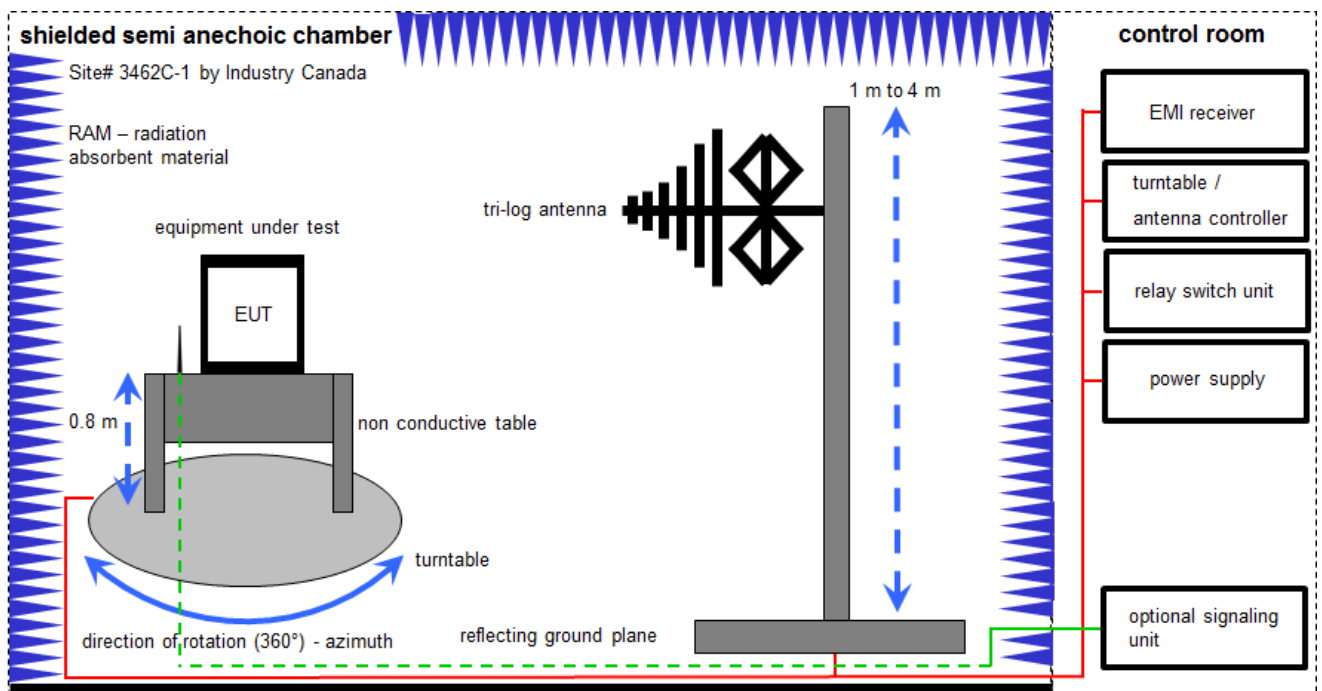

Measurement distance: tri-log antenna 10 meter

$$FS = UR + CL + AF$$

(FS-field strength; UR-voltage at the receiver; CL-loss of the cable; AF-antenna factor)

Example calculation:

$$FS [dB\mu V/m] = 12.35 [dB\mu V/m] + 1.90 [dB] + 16.80 [dB/m] = 31.05 [dB\mu V/m] (35.69 \mu V/m)$$

Equipment table:

No.	Lab / Item	Equipment	Type	Manufacturer	Serial No.	INV. No CTC adv.	Kind of Calibration	Last Calibration	Next Calibration
1	45	Switch-Unit	3488A	HP	2719A14505	300000368	ev		
2	50	DC power supply, 60Vdc, 50A, 1200 W	6032A	HP	2920A04466	300000580	ne		
3	n. a.	EMI Test Receiver	ESCI 3	R&S	100083	300003312	k	08.03.2016	08.03.2017
4	n. a.	Analyzer-Reference-System (Harmonics and Flicker)	ARS 16/1	SPS	A3509 07/0 0205	300003314	Ve	02.02.2016	02.02.2018
5	n. a.	Antenna Tower	Model 2175	ETS-Lindgren	64762	300003745	izw		
6	n. a.	Positioning Controller	Model 2090	ETS-Lindgren	64672	300003746	izw		
7	n. a.	Turntable Interface-Box	Model 105637	ETS-Lindgren	44583	300003747	izw		
8	n. a.	TRILOG Broadband Test-Antenna 30 MHz - 3 GHz	VULB9163	Schwarzbeck	295	300003787	k	25.04.2016	25.04.2018
9	n. a.	Spectrum-Analyzer	FSU26	R&S	200809	300003874	k	29.01.2016	29.01.2017

7.2 Shielded fully anechoic chamber

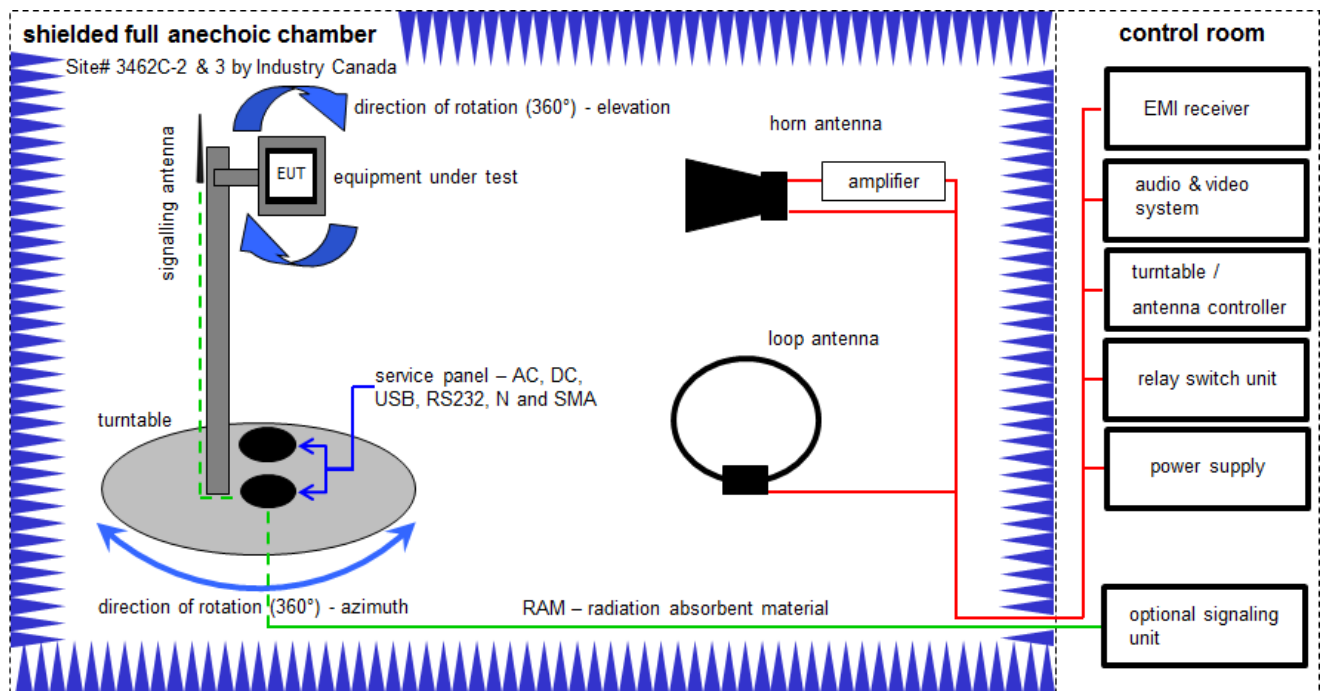

Measurement distance: horn antenna 3 meter; loop antenna 3 meter / 1 meter

FS = UR + CA + AF
(FS-field strength; UR-voltage at the receiver; CA-loss of the signal path; AF-antenna factor)

Example calculation:

$$FS [dB\mu V/m] = 40.0 [dB\mu V/m] + (-35.8) [dB] + 32.9 [dB/m] = 37.1 [dB\mu V/m] (71.61 \mu V/m)$$

Equipment table:

No.	Lab / Item	Equipment	Type	Manufacturer	Serial No.	INV. No CTC adv.	Kind of Calibration	Last Calibration	Next Calibration
1	n. a.	DC power supply, 60Vdc, 50A, 1200 W	6032A	HP	2818A03450	300001040	Ve	20.01.2015	20.01.2018
2	n. a.	Double-Ridged Waveguide Horn Antenna 1-18.0GHz	3115	EMCO	8812-3088	300001032	vIKI!	20.05.2015	20.05.2017
3	n. a.	Anechoic chamber	FAC 3/5m	MWB / TDK	87400/02	300000996	ev		
4	n. a.	Switch / Control Unit	3488A	HP	*	300000199	ne		
5	90	Active Loop Antenna 10 kHz to 30 MHz	6502	EMCO/2	8905-2342	300000256	k	24.06.2015	24.06.2017
6	n. a.	Amplifier	js42-00502650-28-5a	Parzich GMBH	928979	300003143	ne		
7	n. a.	Highpass Filter	WHKX7.0/18G-8SS	Wainwright	18	300003789	ne		
8	n. a.	TRILOG Broadband Test-Antenna 30 MHz - 3 GHz	VULB9163	Schwarzbeck	371	300003854	vIKI!	29.10.2014	29.10.2017
9	n. a.	4U RF Switch Platform	L4491A	Agilent Technologies	MY50000037	300004509	ne		
10	n. a.	EMI Test Receiver 9kHz-26,5GHz	ESR26	R&S	101376	300005063	k	04.09.2015	04.09.2016
11	A026	Std. Gain Horn Antenna 12.4 to 18.0 GHz	639	Narda	8402	300000787	k	14.08.2015	14.08.2017
12	A033	Spectrum Analyzer 20 Hz - 50 GHz	FSU50	R&S	200012	300003443	Ve	02.10.2014	02.10.2016

7.3 Radiated measurements > 18 GHz

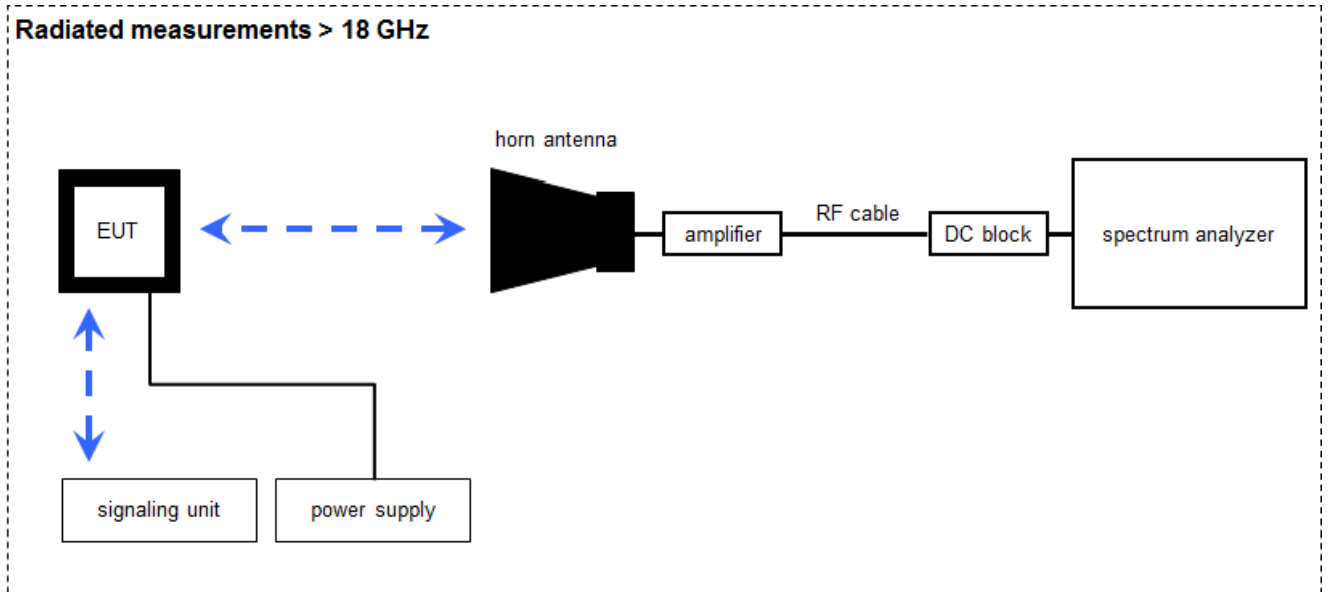

$$FS = UR + CA + AF$$

(FS-field strength; UR-voltage at the receiver; CA-loss signal path & distance correction; AF-antenna factor)

Example calculation:

$$FS [dB\mu V/m] = 40.0 [dB\mu V/m] + (-60.1) [dB] + 36.74 [dB/m] = 16.64 [dB\mu V/m] (6.79 \mu V/m)$$

$$OP = AV + D - G + CA$$

(OP-radiated output power; AV-analyzer value; D-free field attenuation of measurement distance; G-antenna gain+amplifier gain; CA-loss signal path)

Example calculation:

$$OP [dBm] = -59.0 [dBm] + 44.0 [dB] - 20.0 [dBi] + 5.0 [dB] = -30 [dBm] (1 \mu W)$$

Equipment table:

No.	Lab / Item	Equipment	Type	Manufacturer	Serial No.	INV. No CTC adv.	Kind of Calibration	Last Calibration	Next Calibration
1	A030	Std. Gain Horn Antenna 18.0 to 26.5 GHz	638	Narda	8402	300000487	ne	-/-	-/-
2	A031	Std. Gain Horn Antenna 26.5 to 40.0 GHz	V637	Narda	82-16	300000510	k	14.08.2015	14.08.2017
3	A031	Std. Gain Horn Antenna 33.0-50.1 GHz	2324-20	Flann	57	400000683	ne	-/-	-/-
4	A031	Broadband LNA 18-50 GHz	CBL18503070PN	CERNEX	25240	300004948	ev	-/-	-/-
5	A025	Std. Gain Horn Antenna 49.9-75.8 GHz	2524-20	Flann	*	300001983	ne	-/-	-/-
6	A028	Std. Gain Horn Antenna 73.8-112 GHz	2724-20	Flann	*	300001991	ne	-/-	-/-
7	A032	Std. Gain Horn Antenna 114-173 GHz	2924-20	Flann	*	300001999	ne	-/-	-/-
8	A033	Std. Gain Horn Antenna 145-220 GHz	3024-20	Flann	*	300002000	ne	-/-	-/-
9	A033	Power Supply	LA30/5GA	Zentro	2046	300000711	NK!	-/-	-/-
10	A033	Spectrum Analyzer 20 Hz - 50 GHz	FSU50	R&S	200012	300003443	Ve	02.10.2014	02.10.2016
11	A033	Temperature Test Chamber	T-40/50	CTS GmbH	064023	300003540	ev	03.09.2015	03.09.2017
12	A033	Harmonic Mixer 2-Port, 50-75 GHz	FS-Z75	R&S	100099	300003949	k	09.03.2016	09.03.2017
13	A033	Harmonic Mixer 3-Port, 110-170 GHz	SAM-170	Radiometer Physics GmbH	100014	300004156	k	23.05.2016	23.05.2018
14	A033	Harmonic Mixer 3-Port, 170-220 GHz	SAM-220	Radiometer Physics GmbH	200001	300004157	k	09.06.2016	09.06.2018
15	A033	Harmonic Mixer 3-Port, 220-325 GHz	SAM-325	Radiometer Physics GmbH	100002	300004158	k	30.05.2016	30.05.2018
16	A033	Harmonic Mixer 3-Port, 60-90 GHz	FS-Z90	R&S	101555	300004691	k	12.05.2016	12.05.2017
17	A033	End Launch Adaptor, 60.5 - 92.0GHz	26373-WF60 UG387/U-AC	Flann	227692	300004809	ev	-/-	-/-
18	A033	Std. Gain Horn Antenna 217-330 GHz	32240-20	Flann	233278	300004960	ne	-/-	-/-
19	A033	Harmonic Mixer 3-Port, 75-110 GHz	FS-Z110	R&S	101411	300004959	k	09.03.2006	09.03.2017

8 Sequence of testing

8.1 Sequence of testing radiated spurious 9 kHz to 30 MHz

Setup

- The equipment is set up to simulate normal operation mode as described in the user manual or defined by the manufacturer.
- If the EUT is a tabletop system, a 2-axis positioner with 1.5 m height is used.
- If the EUT is a floor standing device, it is placed directly on the turn table.
- Auxiliary equipment and cables are positioned to simulate normal operation conditions as described in ANSI C 63.4.
- The AC power port of the EUT (if available) is connected to a power outlet below the turntable.
- Measurement distance is 3 m (see ANSI C 63.4) – see test details.
- EUT is set into operation.

Premeasurement

- The turntable rotates from 0° to 315° using 45° steps.
- The antenna height is 1.5 m.
- At each turntable position the analyzer sweeps with positive-peak detector to find the maximum of all emissions.

Final measurement

- Identified emissions during the premeasurement are maximized by the software by rotating the turntable from 0° to 360°. In case of the 2-axis positioner is used the elevation axis is also rotated from 0° to 360°.
- The final measurement is done in the position (turntable and elevation) causing the highest emissions with quasi-peak (as described in ANSI C 63.4).
- Final levels, frequency, measuring time, bandwidth, turntable position, correction factor, margin to the limit and limit will be recorded. A plot with the graph of the premeasurement and the limit is stored.

8.2 Sequence of testing radiated spurious 30 MHz to 1 GHz

Setup

- The equipment is set up to simulate normal operation mode as described in the user manual or defined by the manufacturer.
- If the EUT is a tabletop system, a table with 0.8 m height is used, which is placed on the ground plane.
- If the EUT is a floor standing device, it is placed on the ground plane with insulation between both.
- Auxiliary equipment and cables are positioned to simulate normal operation conditions as described in ANSI C 63.4.
- The AC power port of the EUT (if available) is connected to a power outlet below the turntable.
- Measurement distance is 10 m or 3 m (see ANSI C 63.4) – see test details.
- EUT is set into operation.

Premeasurement

- The turntable rotates from 0° to 315° using 45° steps.
- The antenna is polarized vertical and horizontal.
- The antenna height changes from 1 m to 3 m.
- At each turntable position, antenna polarization and height the analyzer sweeps three times in peak to find the maximum of all emissions.

Final measurement

- The final measurement is performed for at least six highest peaks according to the requirements of the ANSI C63.4.
- Based on antenna and turntable positions at which the peak values are measured the software maximize the peaks by changing turntable position $\pm 45^\circ$ and antenna height between 1 and 4 m.
- The final measurement is done with quasi-peak detector (as described in ANSI C 63.4).
- Final levels, frequency, measuring time, bandwidth, antenna height, antenna polarization, turntable angle, correction factor, margin to the limit and limit are recorded. A plot with the graph of the premeasurement with marked maximum final results and the limit is stored.

8.3 Sequence of testing radiated spurious 1 GHz to 18 GHz

Setup

- The equipment is set up to simulate normal operation mode as described in the user manual or defined by the manufacturer.
- If the EUT is a tabletop system, a 2-axis positioner with 1.5 m height is used.
- If the EUT is a floor standing device, it is placed directly on the turn table.
- Auxiliary equipment and cables are positioned to simulate normal operation conditions as described in ANSI C 63.4.
- The AC power port of the EUT (if available) is connected to a power outlet below the turntable.
- Measurement distance is 3 m (see ANSI C 63.4) – see test details.
- EUT is set into operation.

Premeasurement

- The turntable rotates from 0° to 315° using 45° steps.
- The antenna is polarized vertical and horizontal.
- The antenna height is 1.5 m.
- At each turntable position and antenna polarization the analyzer sweeps with positive peak detector to find the maximum of all emissions.

Final measurement

- The final measurement is performed for at least six highest peaks according to the requirements of the ANSI C63.4.
- Based on antenna and turntable positions at which the peak values are measured the software maximizes the peaks by rotating the turntable from 0° to 360°. This measurement is repeated for different EUT-table positions (0° to 150° in 30°-steps) and for both antenna polarizations.
- The final measurement is done in the position (turntable, EUT-table and antenna polarization) causing the highest emissions with Peak and RMS detector (as described in ANSI C 63.4).
- Final levels, frequency, measuring time, bandwidth, turntable position, EUT-table position, antenna polarization, correction factor, margin to the limit and limit are recorded. A plot with the graph of the premeasurement with marked maximum final results and the limit is stored.

8.4 Sequence of testing radiated spurious above 18 GHz

Setup

- The equipment is set up to simulate normal operation mode as described in the user manual or defined by the manufacturer.
- Auxiliary equipment and cables are positioned to simulate normal operation conditions as described in ANSI C 63.4.
- The AC power port of the EUT (if available) is connected to a power outlet.
- The measurement distance is as appropriate (e.g. 0.5 m).
- The EUT is set into operation.

Premeasurement

- The test antenna is handheld and moved carefully over the EUT to cover the EUT's whole sphere and different polarizations of the antenna.

Final measurement

- The final measurement is performed at the position and antenna orientation causing the highest emissions with Peak and RMS detector (as described in ANSI C 63.4).
- Final levels, frequency, measuring time, bandwidth, correction factor, margin to the limit and limit are recorded. A plot with the graph of the premeasurement and the limit is stored.

8.5 Sequence of testing radiated spurious above 50 GHz with external mixers

Setup

- The equipment is set up to simulate normal operation mode as described in the user manual or defined by the manufacturer.
- Auxiliary equipment and cables are positioned to simulate normal operation conditions as described in ANSI C 63.4.
- The AC power port of the EUT (if available) is connected to a power outlet.
- The measurement distance is as appropriate for far field (e.g. 0.25 m).
- The EUT is set into operation.

Premeasurement

- The test antenna with external mixer is handheld and moved carefully over the EUT to cover the EUT's whole sphere and different polarizations of the antenna.
- Caution is taken to reduce the possible overloading of the external mixer.

Final measurement

- The final measurement is performed at the position and antenna orientation causing the highest emissions with Peak and RMS detector (as described in ANSI C 63.4).
- As external mixers may generate false images care is taken to ensure that any emission measured by the spectrum analyzer does indeed originate in the EUT. Signal identification feature of spectrum analyzer is used to eliminate false mixer images (i.e., it is not the fundamental emission or a harmonic falling precisely at the measured frequency).
- Final levels, frequency, measuring time, bandwidth, correction factor, margin to the limit and limit are recorded. A plot with the graph of the premeasurement and the limit is stored.

9 Summary of measurement results

<input checked="" type="checkbox"/>	No deviations from the technical specifications were ascertained
<input type="checkbox"/>	There were deviations from the technical specifications ascertained
<input type="checkbox"/>	This test report is only a partial test report. The content and verdict of the performed test cases are listed below.

TC Identifier	Description	Verdict	Date	Remark
RF-Testing	47 CFR Part 95 Subpart M RSS – 251 Issue 1	see below	2017-11-20	-/-

Test specification clause	Test case	Temperature conditions	Power source voltages	Pass	Fail	NA	NP	Results (max.)
§95.3367 (a) / (b) RSS-251 (5.2.2)	Power density	Nominal and Extreme	Nominal and Extreme	<input checked="" type="checkbox"/>	<input type="checkbox"/>	<input type="checkbox"/>	<input type="checkbox"/>	23.9 dBm
§2.1049 RSS-Gen	Occupied bandwidth (99% bandwidth)	Nominal and Extreme	Nominal and Extreme	<input checked="" type="checkbox"/>	<input type="checkbox"/>	<input type="checkbox"/>	<input type="checkbox"/>	760 MHz
§95.3379 (a)(1) §95.3379 (a)(2) §95.3379 (a)(3) RSS-251 (5.3)	Field strength of emissions (radiated spurious)	Nominal	Nominal	<input checked="" type="checkbox"/>	<input type="checkbox"/>	<input type="checkbox"/>	<input type="checkbox"/>	complies
§95.3379 (b) RSS-251 (5.4)	Frequency stability	Nominal and Extreme	Nominal and Extreme	<input checked="" type="checkbox"/>	<input type="checkbox"/>	<input type="checkbox"/>	<input type="checkbox"/>	complies

Note: NA = Not Applicable; NP = Not Performed

10 Measurement results

10.1 Power density

Measurement results:

Normal mode:

EUT	TEST CONDITIONS	TRANSMITTER Power Density	
		Peak EIRP [dBm]	AVG EIRP [dBm]
Sample 1	T_{nom} / V_{nom}	23.6	15.2
	$T_{min} / V_{min}-V_{max}$	23.9	18.6
	$T_{max} / V_{min}-V_{max}$	22.7	17.2
Sample 6	T_{nom} / V_{nom}	23.9	15.4

Low frequency:

EUT	TEST CONDITIONS	TRANSMITTER Power Density	
		Peak EIRP [dBm]	
Sample 1	T_{nom} / V_{nom}	25.2	
	$T_{min} / V_{min}-V_{max}$	24.2	
	$T_{max} / V_{min}-V_{max}$	22.1	
Sample 6	T_{nom} / V_{nom}	23.4	

Middle frequency:

EUT	TEST CONDITIONS	TRANSMITTER Power Density	
		Peak EIRP [dBm]	
Sample 1	T_{nom} / V_{nom}	22.9	
	$T_{min} / V_{min}-V_{max}$	23.3	
	$T_{max} / V_{min}-V_{max}$	21.9	
Sample 6	T_{nom} / V_{nom}	23.0	

High frequency:

EUT	TEST CONDITIONS	TRANSMITTER Power Density	
		Peak EIRP [dBm]	
Sample 1	T_{nom} / V_{nom}	22.8	
	$T_{min} / V_{min}-V_{max}$	21.7	
	$T_{max} / V_{min}-V_{max}$	20.0	
Sample 6	T_{nom} / V_{nom}	22.8	

Verdict: Complies

Limits:

FCC §95.3367 (a) (b)

Frequency	Measurement distance	Power Density → EIRP
76.0 - 81.0 GHz	3.0 m	88 $\mu\text{W}/\text{cm}^2$ → 50 dBm (Average) 279 $\mu\text{W}/\text{cm}^2$ → 55 dBm (PEAK)

Limits:

RSS-251 (5.2.2)

Frequency	Measurement distance	Power Density → EIRP
76.0 - 77.0 GHz	3.0 m	88 $\mu\text{W}/\text{cm}^2$ → 50 dBm (Average) 279 $\mu\text{W}/\text{cm}^2$ → 55 dBm (PEAK)

Plot 1: Sample 1, EIRP (Peak detector), T_{nom} / V_{nom} , normal mode

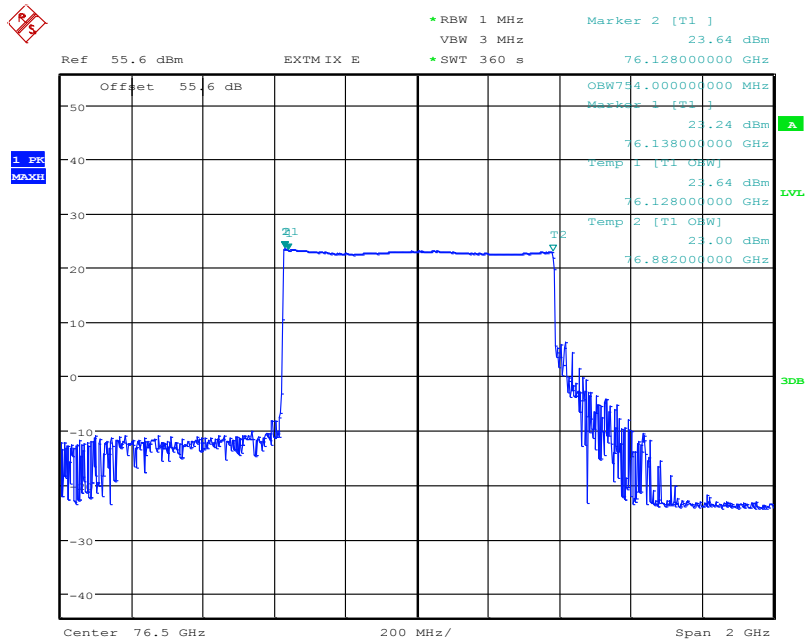

Date: 22.AUG.2016 15:21:04

Plot 2: Sample 1, EIRP (Average detector), T_{nom} / V_{nom} , normal mode

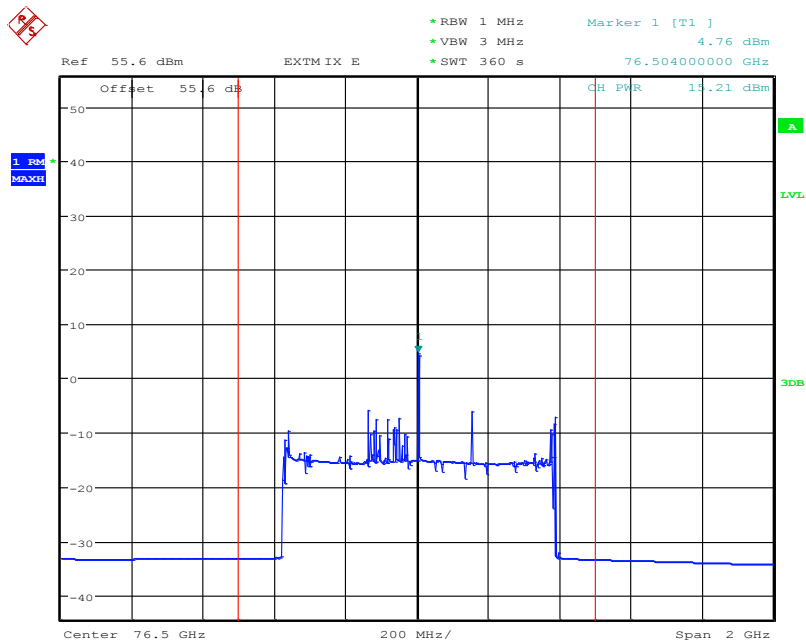

Date: 22.AUG.2016 15:34:22

Plot 3: Sample 1, EIRP (Peak detector), $T_{min} / V_{min}-V_{max}$, normal mode

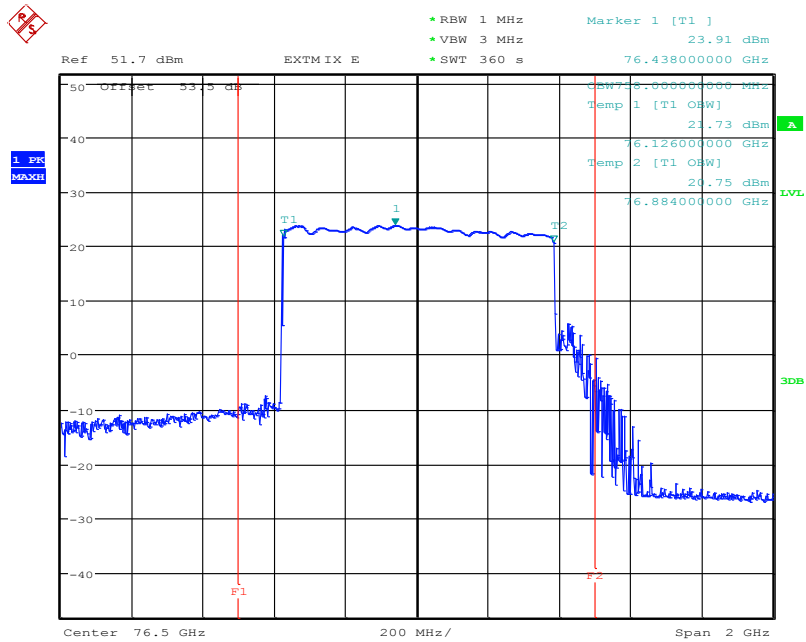

Date: 25.AUG.2016 12:14:21

Plot 4: Sample 1, EIRP (Average detector), $T_{min} / V_{min}-V_{max}$, normal mode

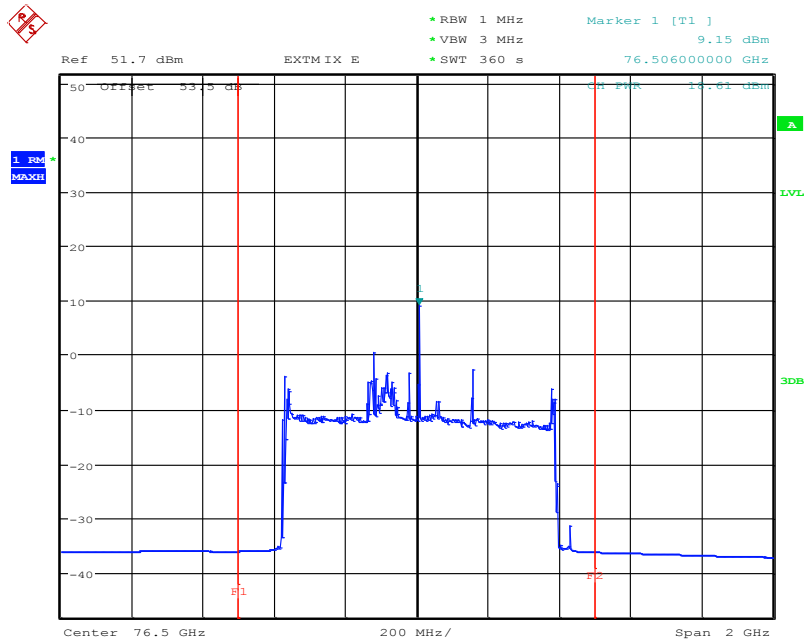

Date: 25.AUG.2016 12:42:29

Plot 5: Sample 1, EIRP (Peak detector), $T_{max} / V_{min}-V_{max}$, normal mode

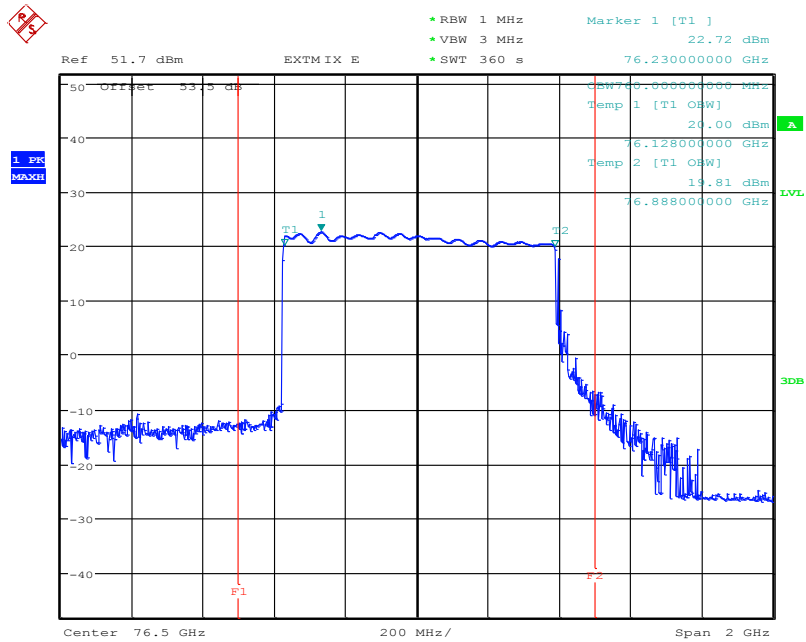

Date: 25.AUG.2016 15:07:55

Plot 6: Sample 1, EIRP (Average detector), $T_{max} / V_{min}-V_{max}$, normal mode

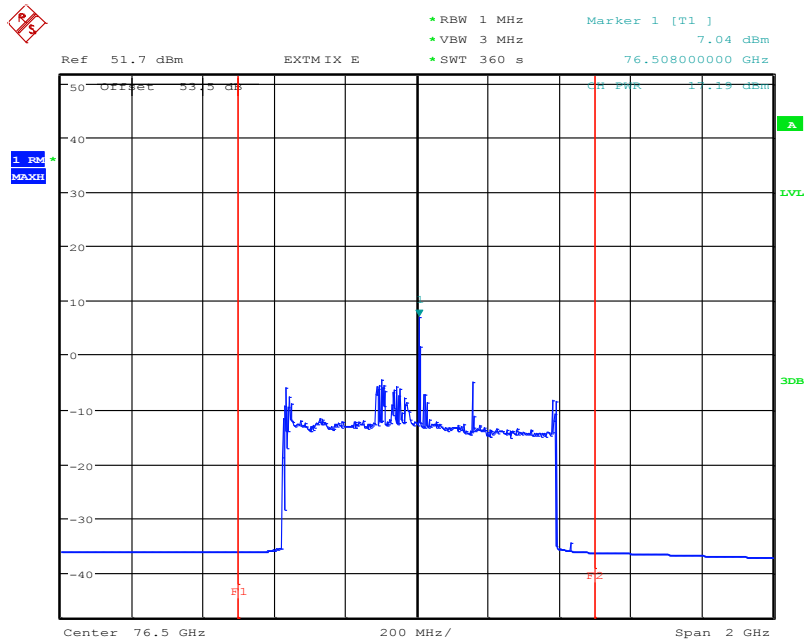

Date: 25.AUG.2016 14:55:42

Plot 7: Sample 1, EIRP, T_{nom} / V_{nom} , low frequency

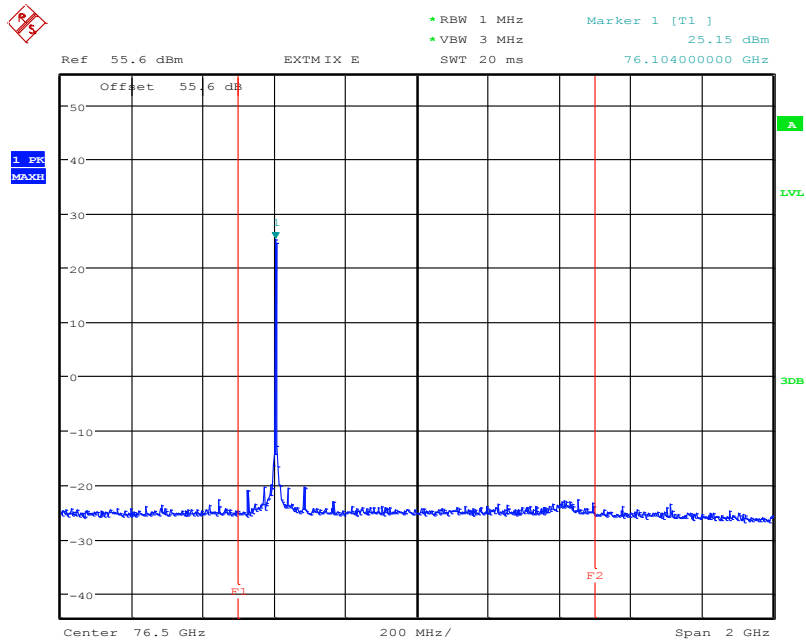

Date: 22.AUG.2016 17:08:40

Plot 8: Sample 1, EIRP, T_{nom} / V_{nom} , middle frequency

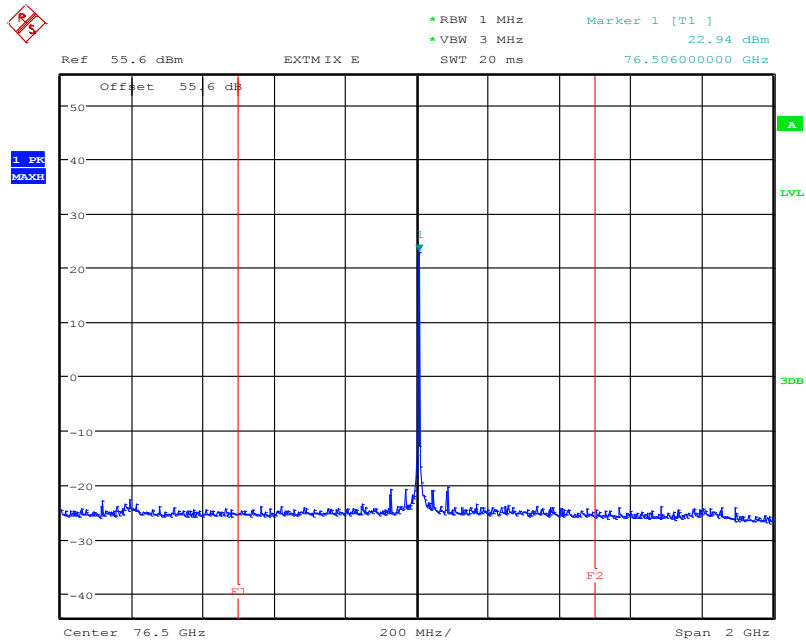

Date: 22.AUG.2016 17:09:25

Plot 9: Sample 1, EIRP, T_{nom} / V_{nom} , high frequency

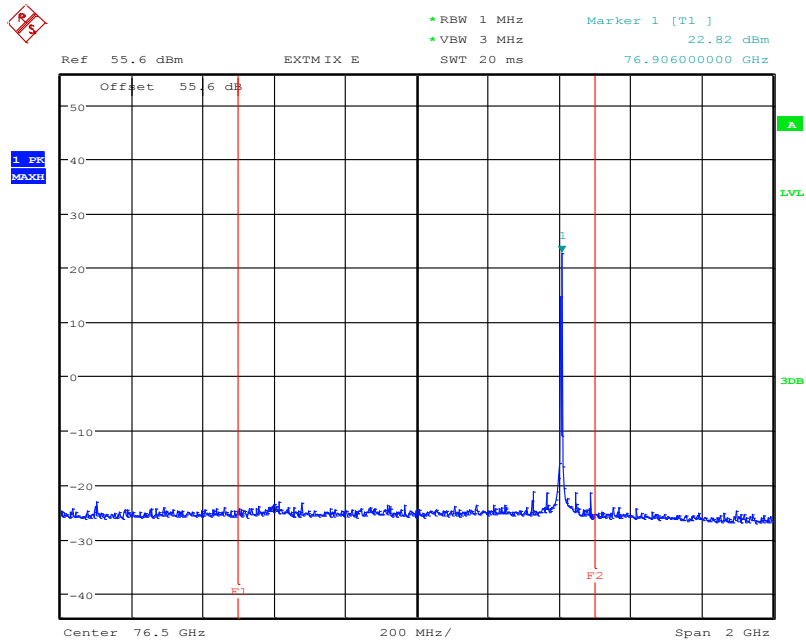

Date: 22.AUG.2016 17:09:58

Plot 10: Sample 1, EIRP, T_{min} / V_{min} - V_{max} , low/middle/high frequency

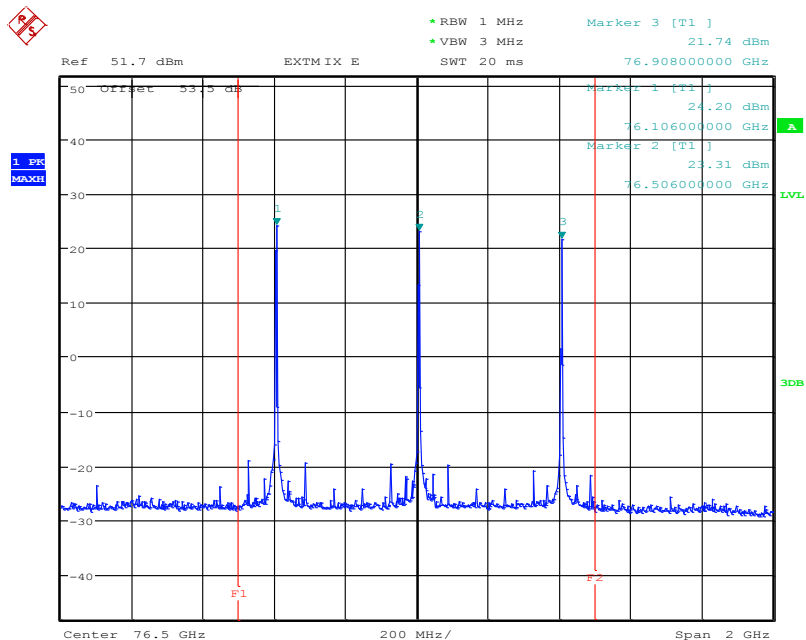

Date: 25.AUG.2016 11:49:36

Plot 11: Sample 1, EIRP, $T_{max} / V_{min}-V_{max}$, low/middle/high frequency

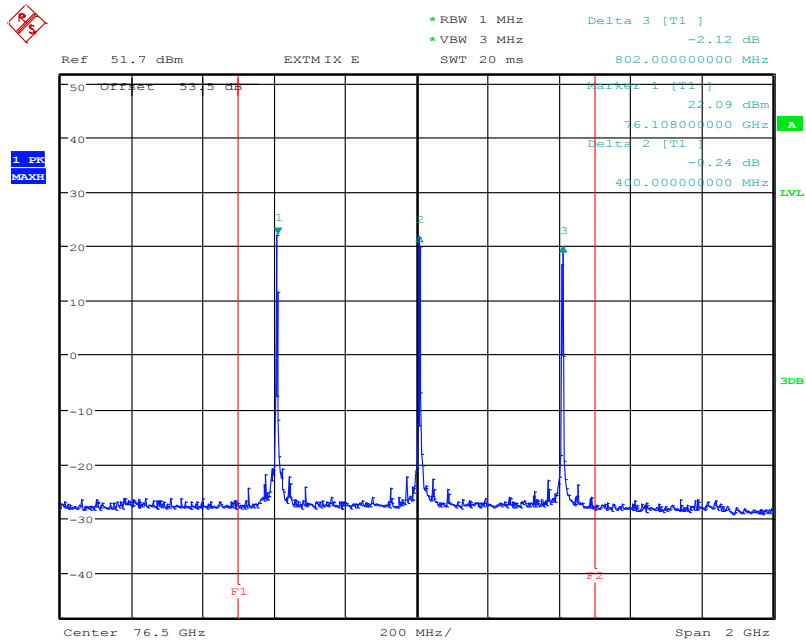

Date: 25.AUG.2016 15:13:10

Plot 12: Sample 6, EIRP (Peak detector), T_{nom} / V_{nom} , normal mode

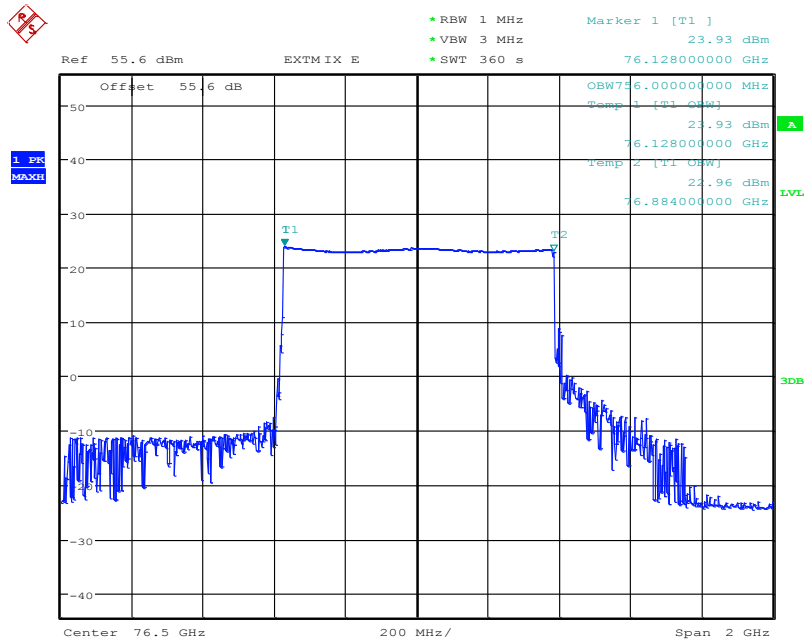

Date: 22.AUG.2016 16:18:40

Plot 13: Sample 6 , EIRP (Average detector), T_{nom} / V_{nom} , normal mode

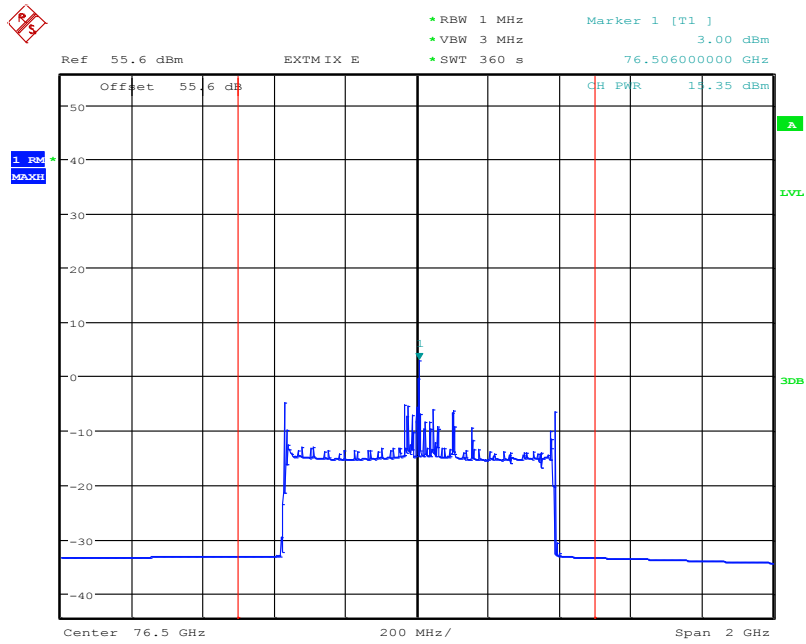

Date: 22.AUG.2016 16:49:44

Plot 14: Sample 6, EIRP, T_{nom} / V_{nom} , low frequency

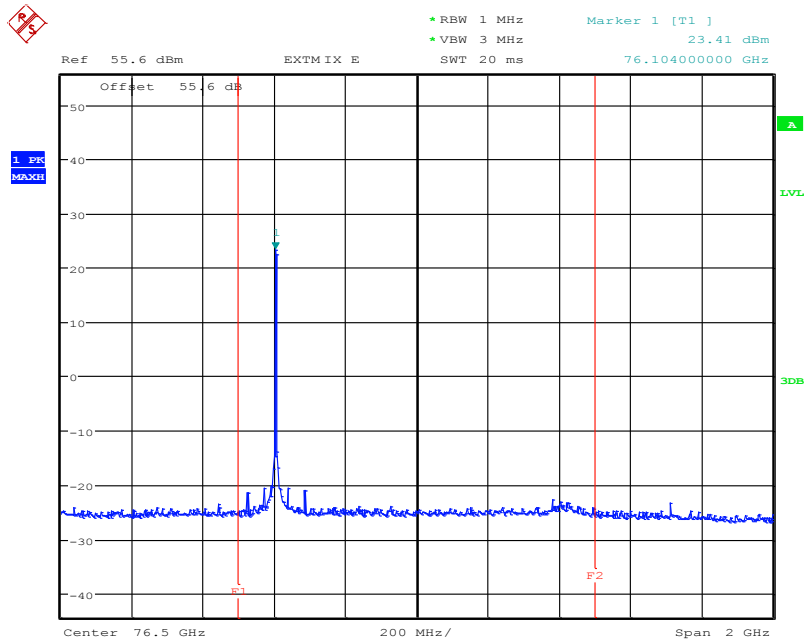

Date: 22.AUG.2016 16:57:51

Plot 15: Sample 6, EIRP, T_{nom} / V_{nom} , middle frequency

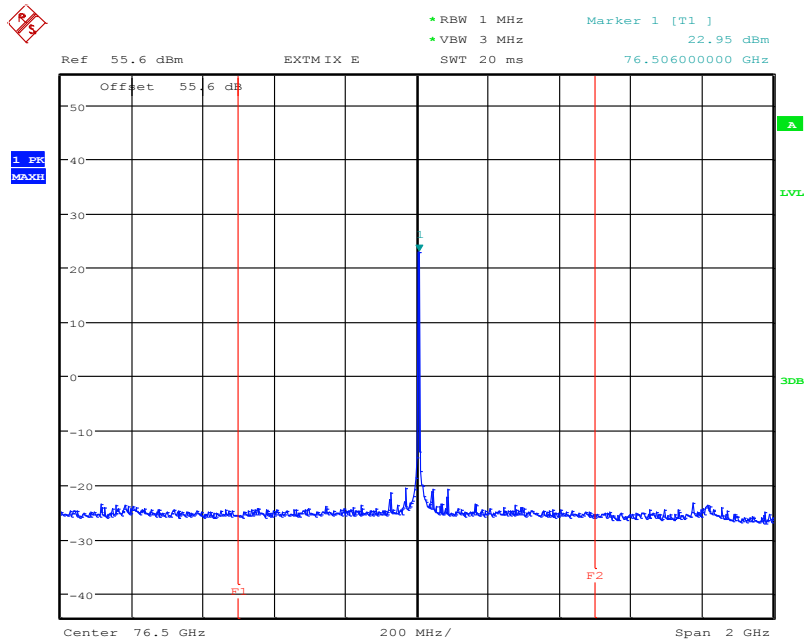

Date: 22.AUG.2016 16:58:58

Plot 16: Sample 6, EIRP, T_{nom} / V_{nom} , high frequency

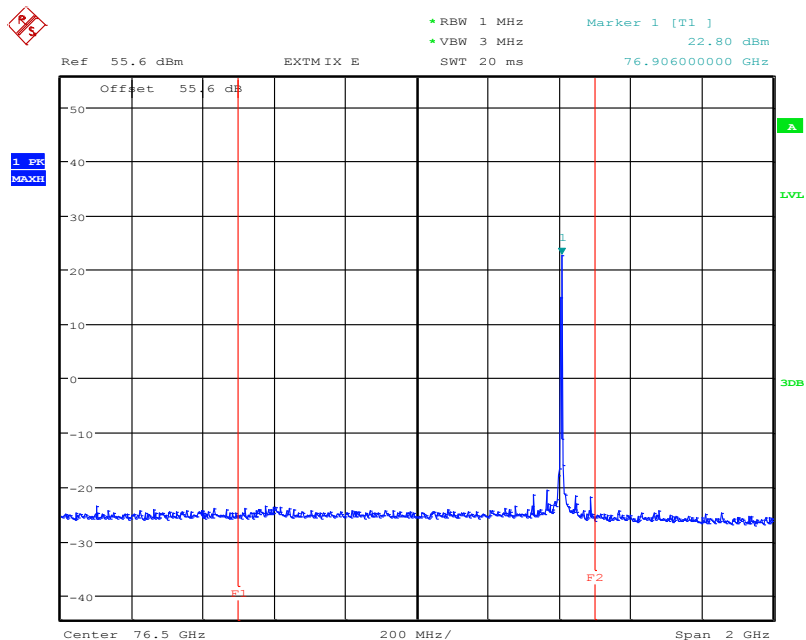

Date: 22.AUG.2016 16:59:43

10.2 Occupied bandwidth

Limits:

FCC §95.3379 (b)

Frequency range	f(lowest) > 76.0 GHz	f(highest) < 81.0 GHz
-----------------	----------------------	-----------------------

Limits:

RSS-251 (5.2.2) / (5.4)

Frequency range	f(lowest) > 76.0 GHz	f(highest) < 77.0 GHz
-----------------	----------------------	-----------------------

Results:

EUT	TEST CONDITIONS	Occupied Bandwidth (99%) (MHz)	Plot (chapter 10.1)
Sample 1	T_{nom} / V_{nom}	745.0	1
	$T_{min} / V_{min-Vmax}$	750.0	3
	$T_{max} / V_{min-Vmax}$	760.0	5
Sample 6	T_{nom} / V_{nom}	756.0	12

Verdict: Complies

10.3 Field strength of emissions (band edge)

Limits: FCC §95.3379 (a) (2) (i) + (ii) / ANSI C63.10-2013 / 6.10

Frequency Range [GHz]	Measurement distance	Power Density
40 – 200	3.0 m	600 pW/cm ² → -1.7 dBm

Limits: FCC §95.3379 (b)

Frequency range	f(lowest) > 76.0 GHz	f(highest) < 81.0 GHz
-----------------	----------------------	-----------------------

Limits: RSS-251 (5.2.2)

Frequency range	f(lowest) > 76.0 GHz	f(highest) < 77.0 GHz
-----------------	----------------------	-----------------------

Verdict: Complies

Plot 17: Sample 1 (Average detector), T_{nom} / V_{nom} , normal mode

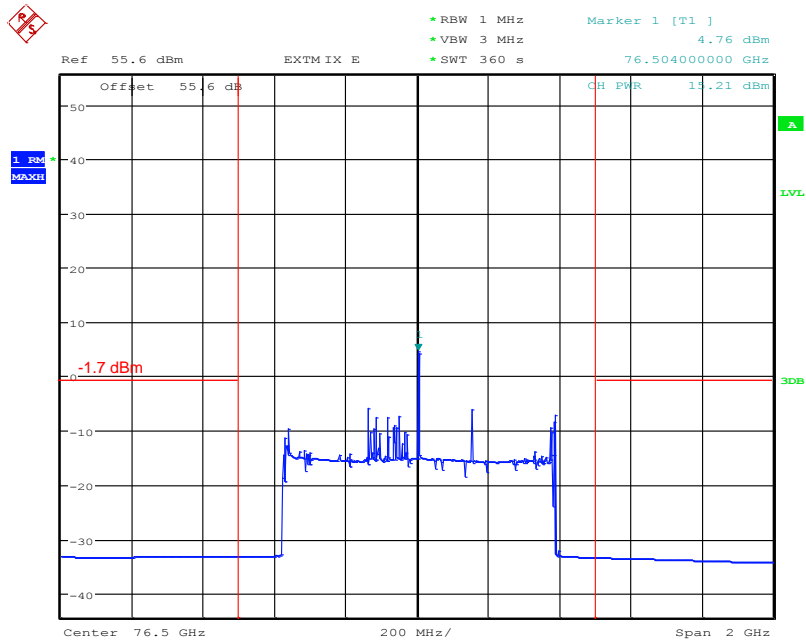

Date: 22.AUG.2016 15:34:22

Plot 18: Sample 6 (Average detector), T_{nom} / V_{nom} , normal mode

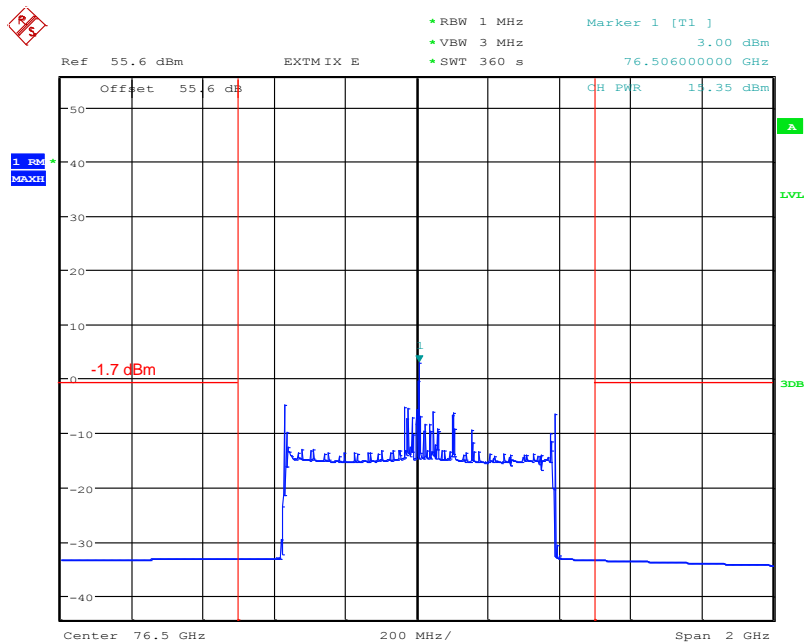

Date: 22.AUG.2016 16:49:44

10.4 Field strength of emissions (radiated spurious)

Description:

Measurement of the radiated spurious emissions in transmit mode.

Limits:

FCC §95.3379

FCC		
CFR Part 95.3379 (a) (1) / CFR Part 95.3379 (a) (3)		
Radiated Spurious Emissions		
Emissions radiated outside of the specified frequency bands, except for harmonics, shall be attenuated by at least 50 dB below the level of the fundamental or to the general radiated emission limits in § 15.209, whichever is the lesser attenuation.		
Frequency [MHz]	Field Strength [dBµV/m]	Measurement distance
0.009 – 0.490	2400/F[kHz]	300
0.490 – 1.705	24000/F[kHz]	30
1.705 – 30.0	30	30
30 – 88	30.0	10
88 – 216	33.5	10
216 – 960	36.0	10
960 – 40 000	54.0	3

Limits:

FCC §95.3379 (a) (2) (i) + (ii) / RSS-251 (5.3)

Frequency Range [GHz]	Measurement distance	Power Density
40 – 200	3.0 m	600 pW/cm ² → -1.7 dBm
200 – 231	3.0 m	1000 pW/cm ² → +0.5 dBm

Results:

TX Spurious Emissions Radiated [dBµV/m]								
Low Channel			Middle Channel			High Channel		
F [GHz]	Detector	Level [dBµV/m]	F [GHz]	Detector	Level [dBµV/m]	F [GHz]	Detector	Level [dBµV/m]
See plots			See plots			See plots		
Measurement uncertainty			± 3 dB					

Verdict: Complies

Plot 19: Sample 1, spurious emissions, 9 kHz – 30 MHz, low frequency

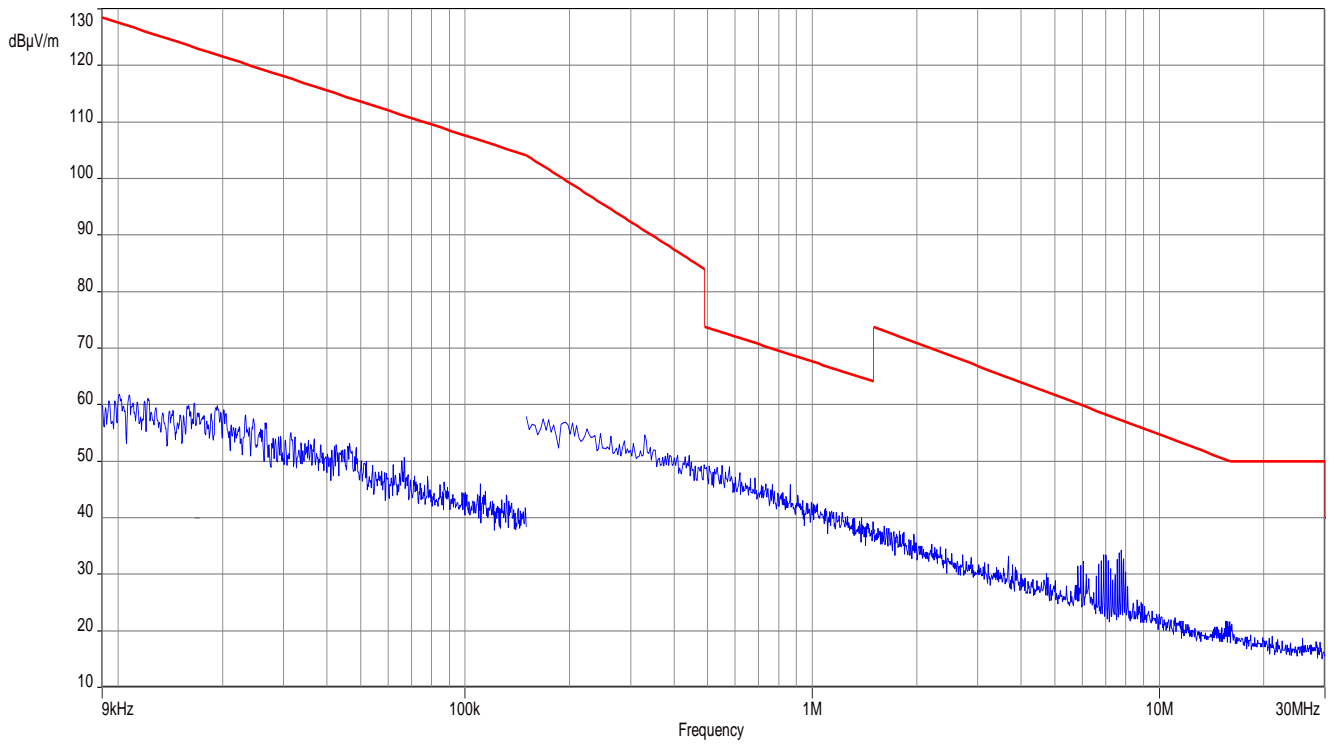

Plot 20: Sample 1, spurious emissions, 9 kHz – 30 MHz, middle frequency

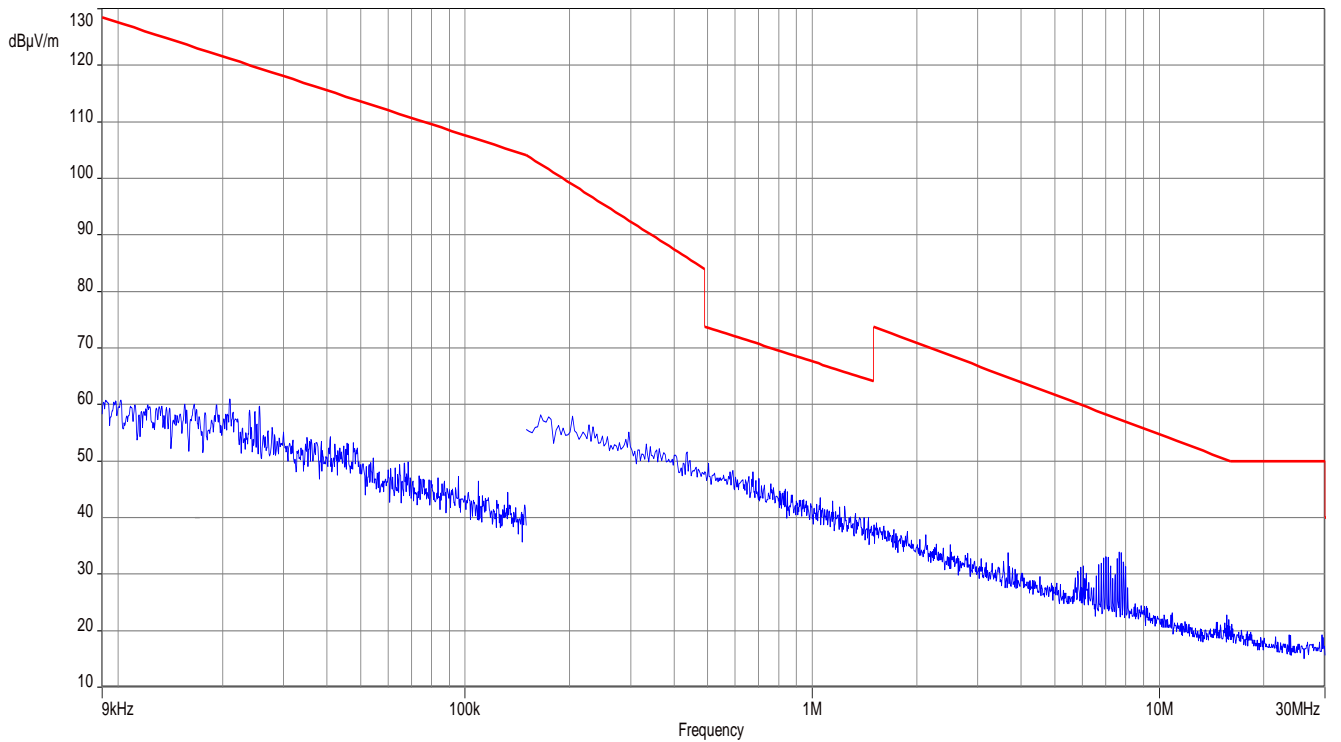

Plot 21: Sample 1, spurious emissions, 9 kHz – 30 MHz, high frequency

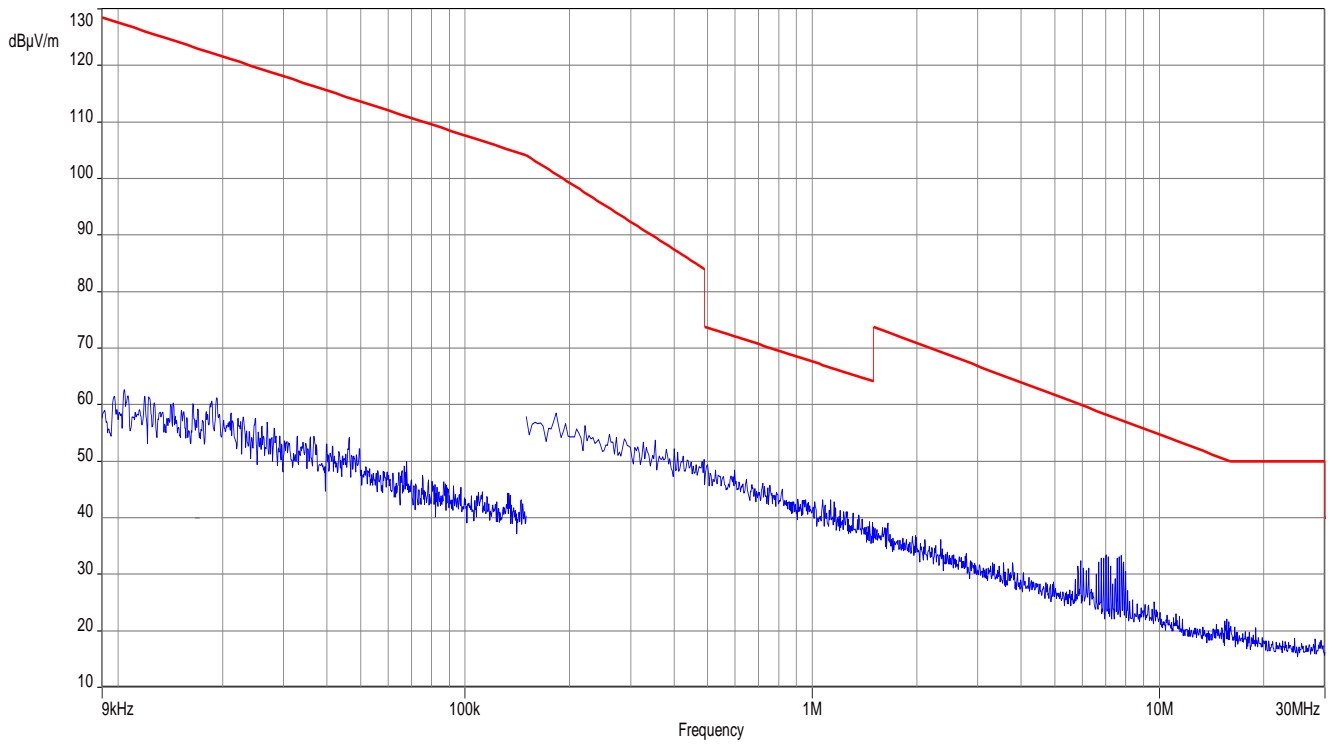

Plot 22: Sample 1, spurious emissions, 30 MHz – 1 GHz, low frequency

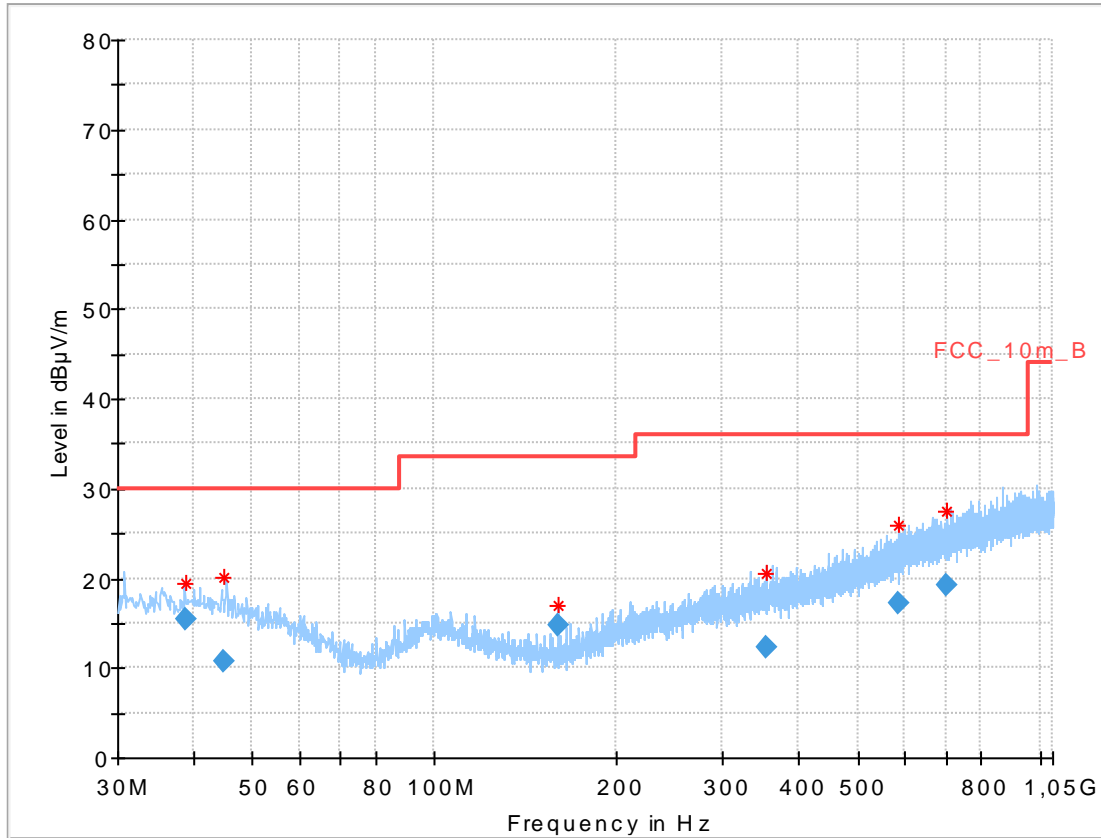

Frequency (MHz)	QuasiPeak (dBµV/m)	Limit (dBµV/m)	Margin (dB)	Meas. Time (ms)	Bandwidth (kHz)	Height (cm)	Pol	Azimuth (deg)	Corr. (dB)
38.716650	15.42	30.00	14.58	1000.0	120.000	101.0	V	280.0	14.0
44.875350	10.75	30.00	19.25	1000.0	120.000	101.0	V	10.0	13.9
160.009800	14.84	33.50	18.66	1000.0	120.000	101.0	V	261.0	9.1
354.016500	12.28	36.00	23.72	1000.0	120.000	170.0	H	260.0	16.1
584.322900	17.20	36.00	18.80	1000.0	120.000	101.0	V	80.0	20.3
703.731150	19.14	36.00	16.86	1000.0	120.000	101.0	V	10.0	21.6

Plot 23: Sample 1, spurious emissions, 30 MHz – 1 GHz, middle frequency

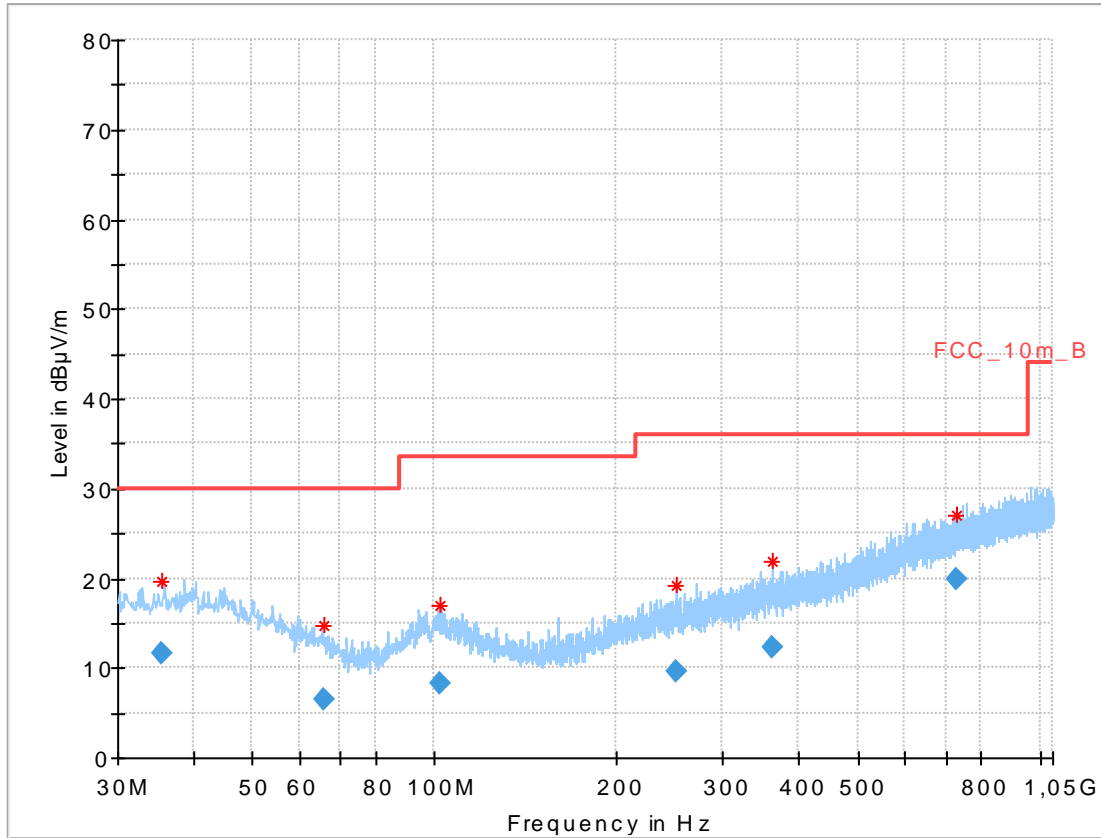

Frequency (MHz)	QuasiPeak (dBµV/m)	Limit (dBµV/m)	Margin (dB)	Meas. Time (ms)	Bandwidth (kHz)	Height (cm)	Pol	Azimuth (deg)	Corr. (dB)
35.361750	11.67	30.00	18.33	1000.0	120.000	101.0	V	170.0	13.8
65.929800	6.46	30.00	23.54	1000.0	120.000	101.0	V	100.0	9.3
102.387750	8.16	33.50	25.34	1000.0	120.000	101.0	V	100.0	11.9
250.113300	9.55	36.00	26.45	1000.0	120.000	170.0	V	190.0	13.4
362.189250	12.40	36.00	23.60	1000.0	120.000	101.0	V	190.0	16.2
730.458150	19.78	36.00	16.22	1000.0	120.000	170.0	H	171.0	22.2

Plot 24: Sample 1, spurious emissions, 30 MHz – 1 GHz, high frequency

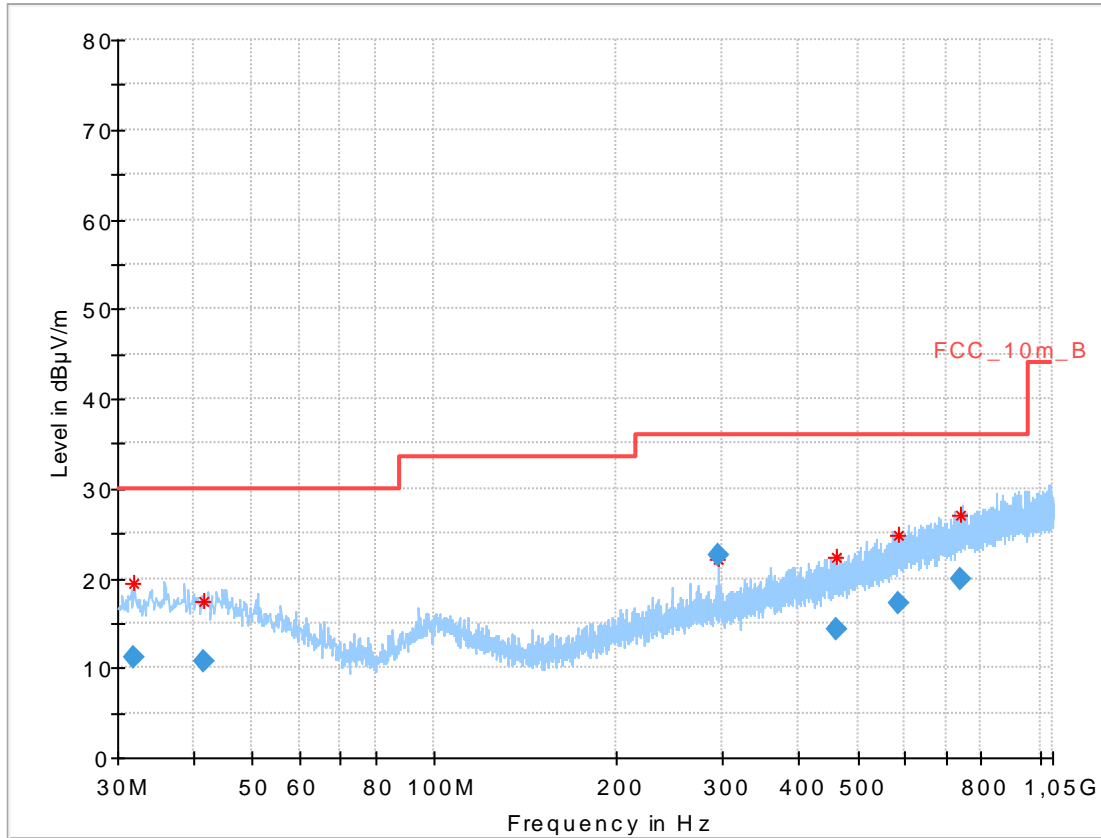

Frequency (MHz)	QuasiPeak (dBµV/m)	Limit (dBµV/m)	Margin (dB)	Meas. Time (ms)	Bandwidth (kHz)	Height (cm)	Pol	Azimuth (deg)	Corr. (dB)
31.827600	11.08	30.00	18.92	1000.0	120.000	98.0	V	280.0	13.5
41.604300	10.70	30.00	19.30	1000.0	120.000	98.0	V	261.0	14.0
293.635650	22.63	36.00	13.37	1000.0	120.000	98.0	V	280.0	14.3
461.089800	14.19	36.00	21.81	1000.0	120.000	101.0	V	100.0	17.9
582.157500	17.30	36.00	18.70	1000.0	120.000	98.0	V	80.0	20.2
738.035850	19.87	36.00	16.13	1000.0	120.000	101.0	H	-10.0	22.4

Plot 25: Sample 1, spurious emissions, 1 GHz – 7 GHz, low frequency

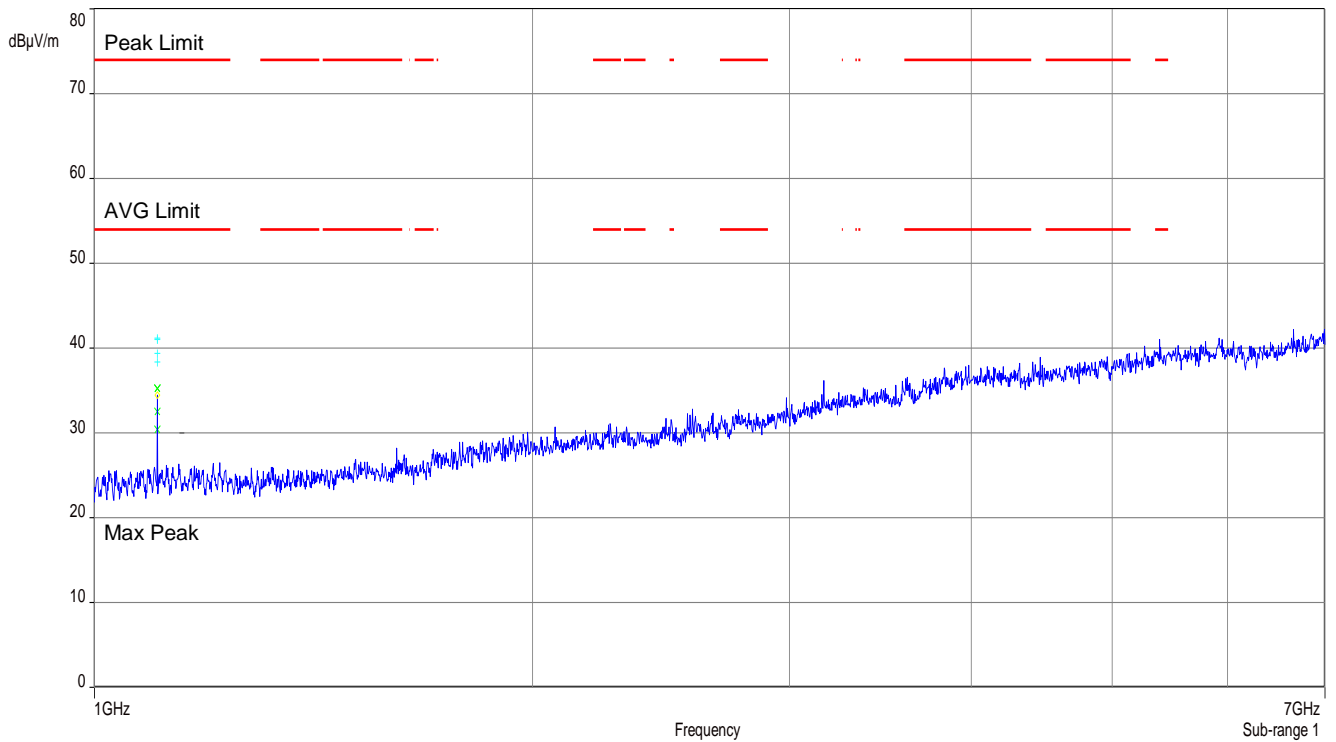

Plot 26: Sample 1, spurious emissions, 1 GHz – 7 GHz, middle frequency

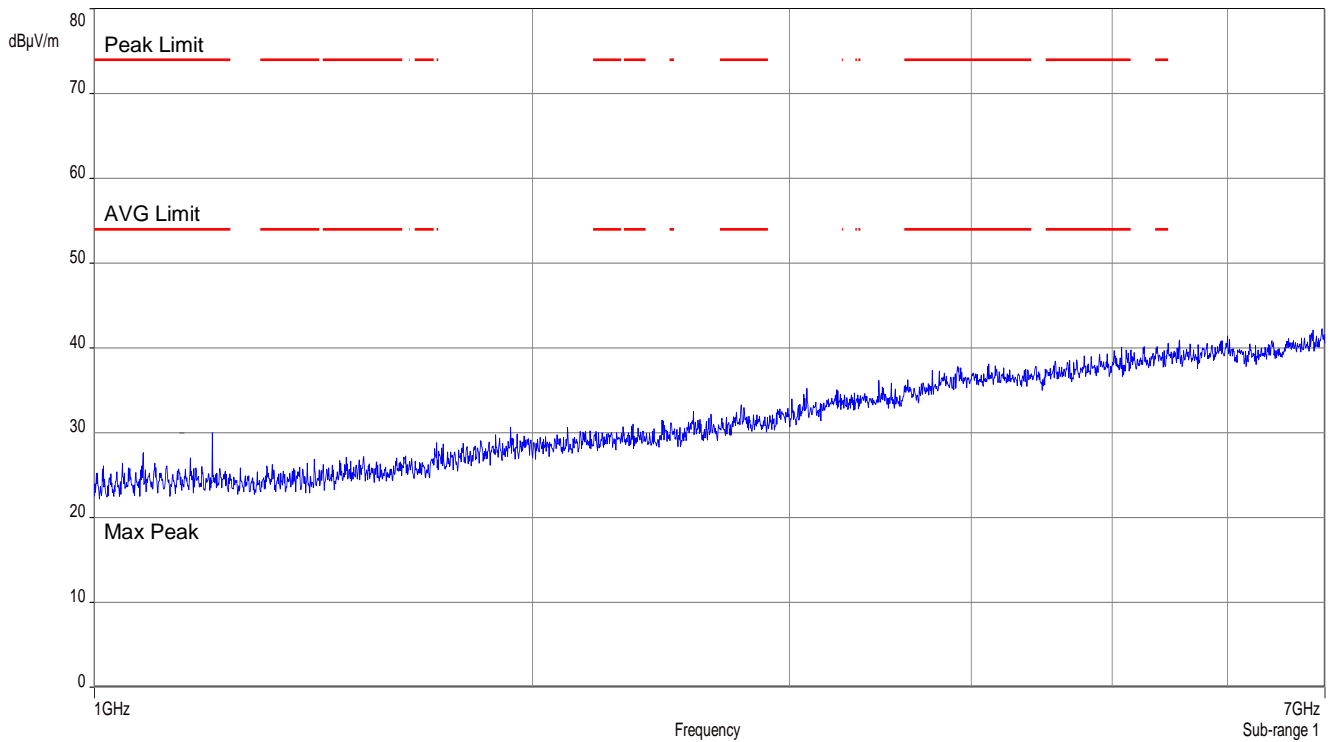

Plot 27: Sample 1, spurious emissions, 1 GHz – 7 GHz, high frequency

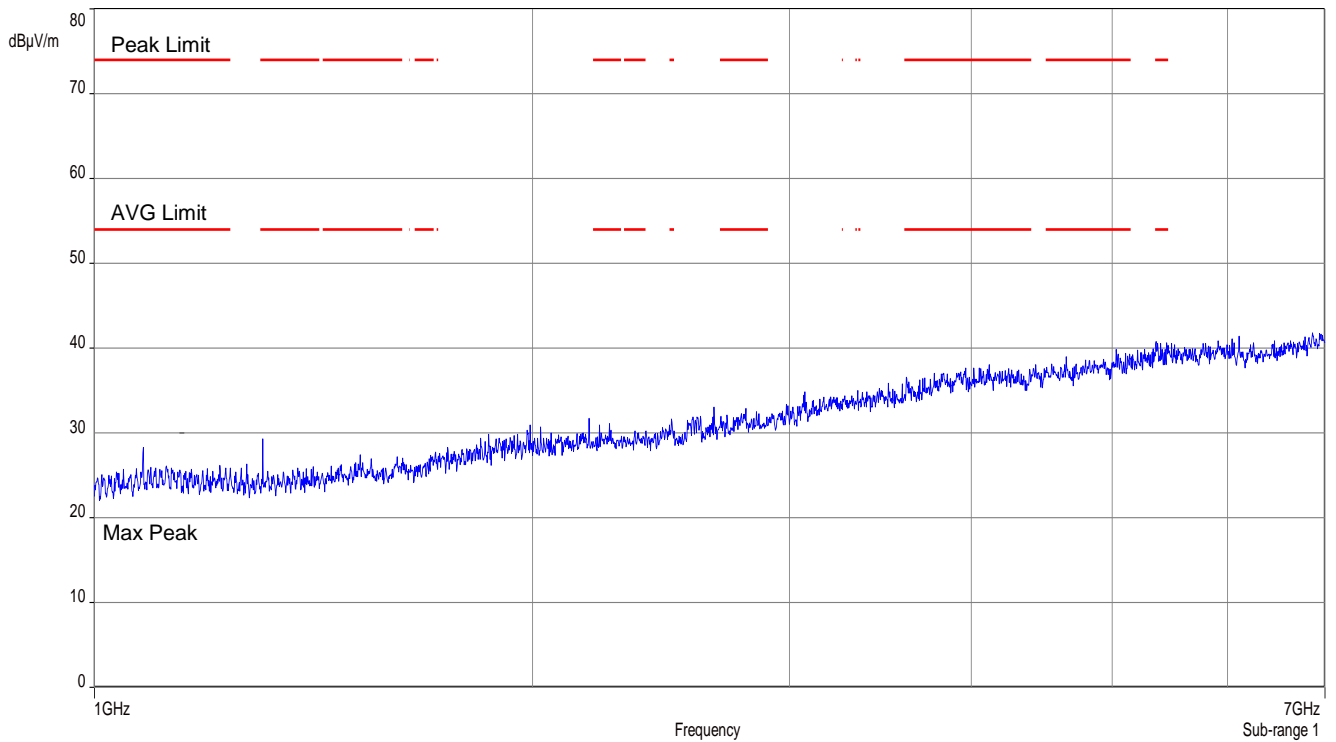

Plot 28: Sample 1, spurious emissions, 7 GHz – 12.75 GHz, low frequency

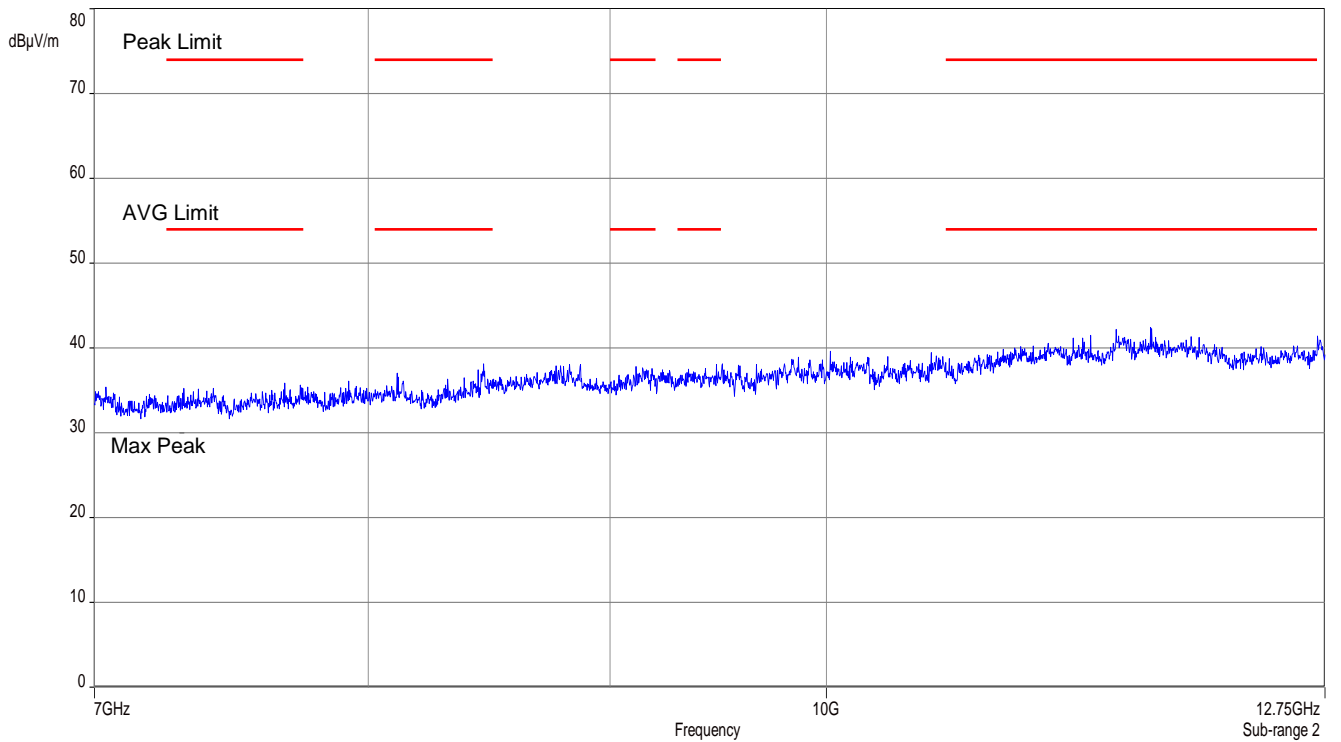

Plot 29: Sample 1, spurious emissions, 7 GHz – 12.75 GHz, middle frequency

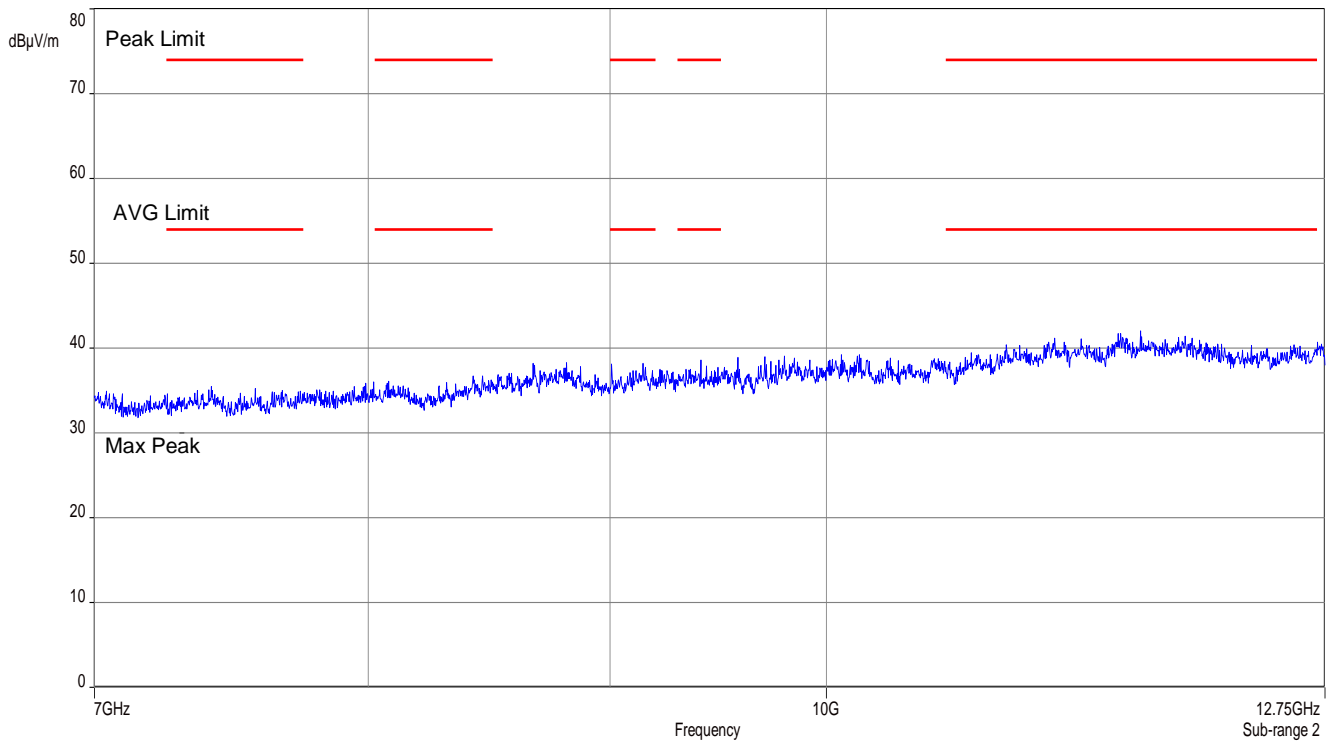

Plot 30: Sample 1, spurious emissions, 7 GHz – 12.75 GHz, high frequency

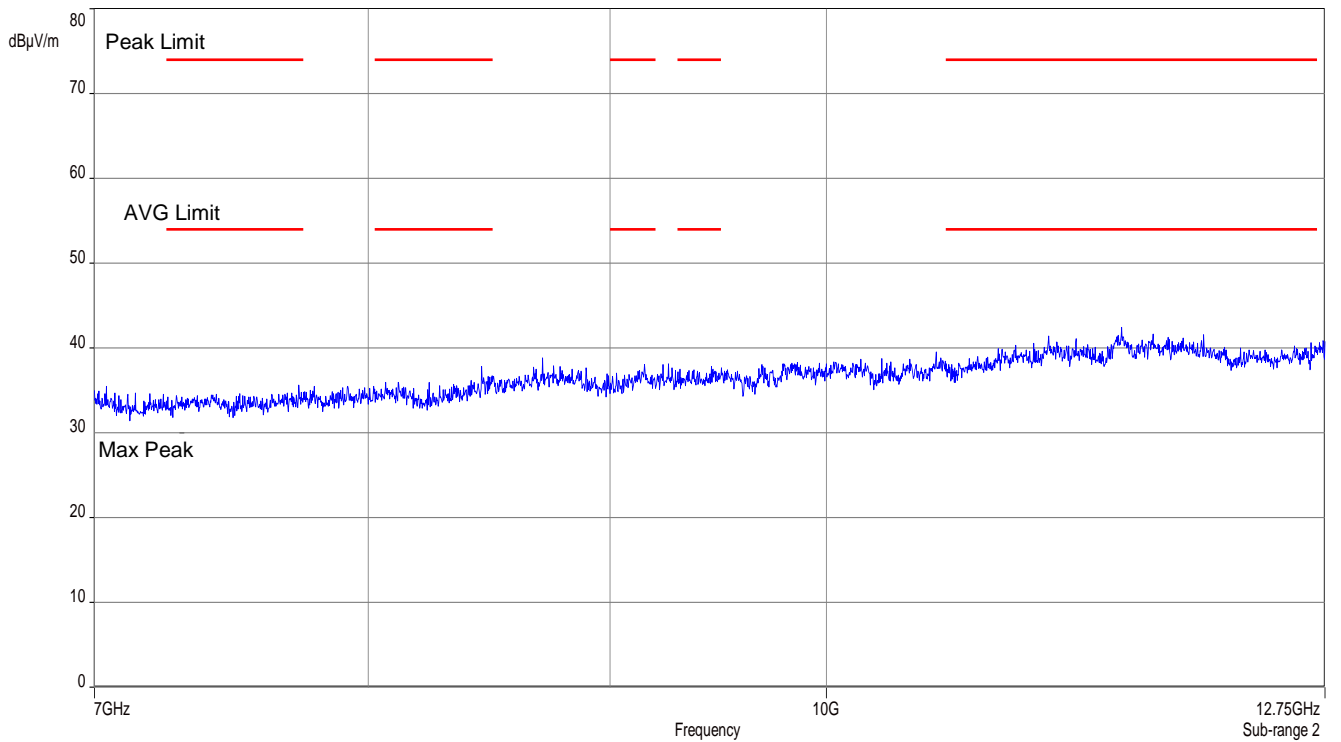

Plot 31: Sample 1, spurious emissions, 12.75 GHz – 18 GHz, low/middle/high frequency

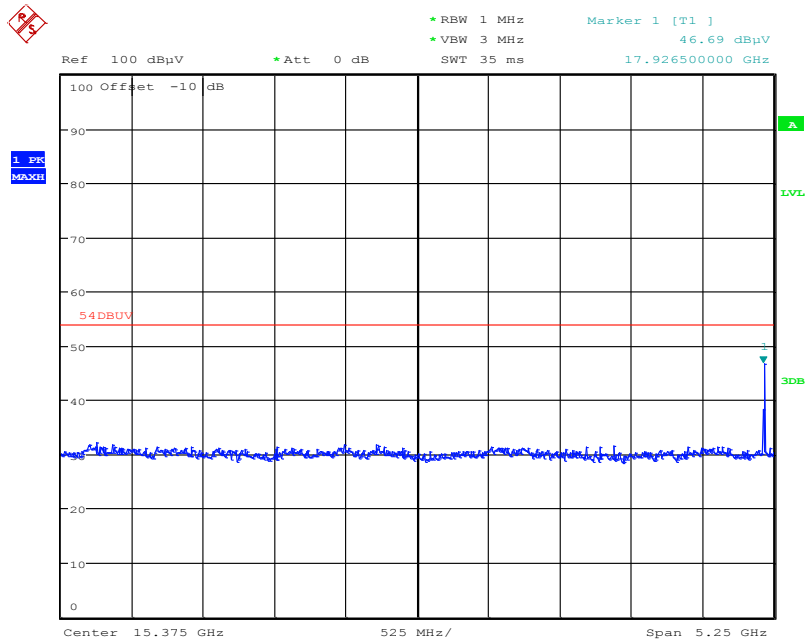

Date: 23.AUG.2016 15:19:02

Plot 32: Sample 1, spurious emissions, 18 GHz – 26.5 GHz, low/middle/high frequency

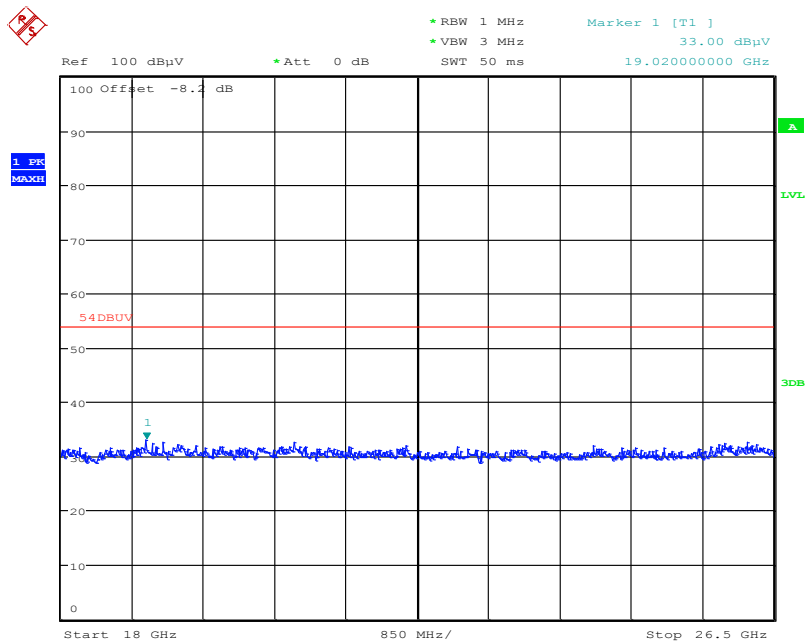

Date: 23.AUG.2016 15:35:11

Plot 33: Sample 1, spurious emissions, 26.5 GHz – 40 GHz, low/middle/high frequency

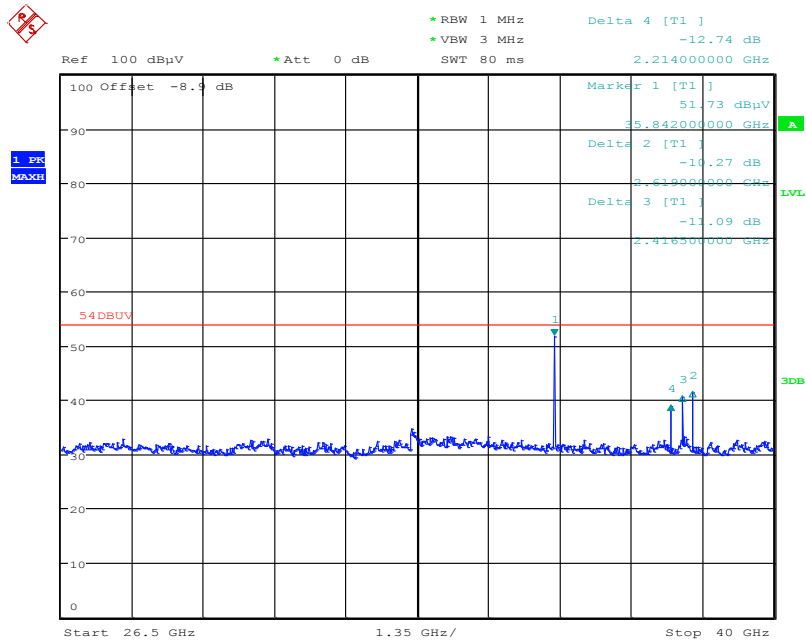

Date: 23.AUG.2016 16:02:36

Marker shows the peak value (limit @ 74 dBuV)

Plot 34: Sample 1, spurious emissions, 40 GHz – 50 GHz, low/middle/high frequency

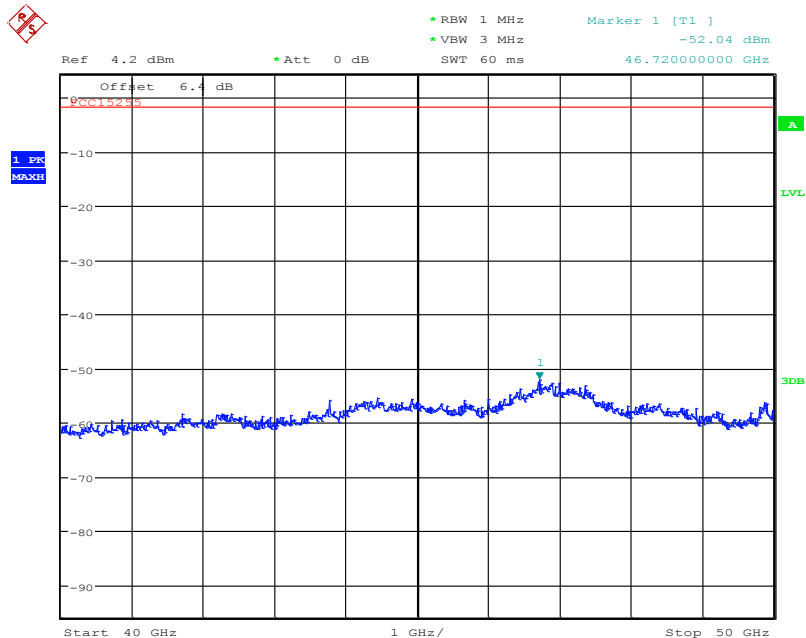

Date: 24.AUG.2016 10:54:36

Plot 35: Sample 1, spurious emissions, 50 GHz – 75 GHz, low/middle/high frequency

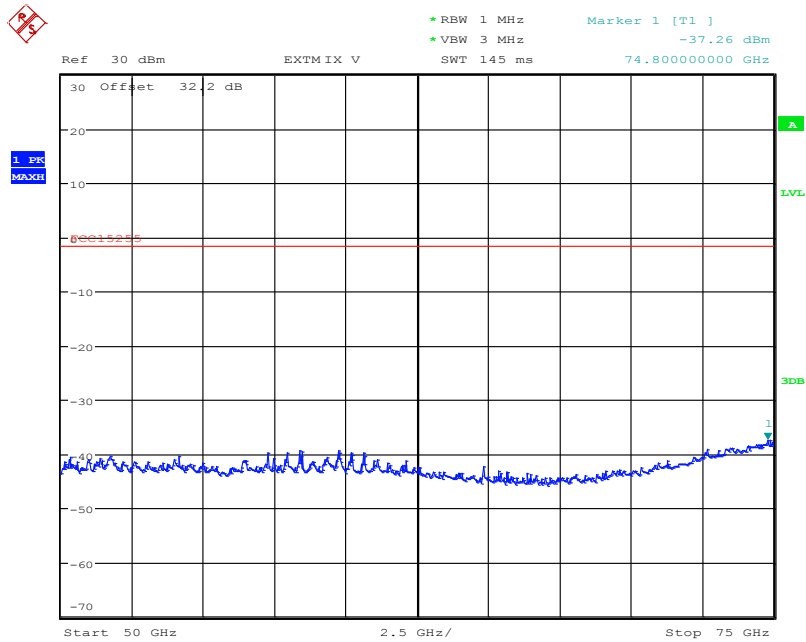

Date: 23.AUG.2016 17:35:02

Plot 36: Sample 1, spurious emissions, 75 GHz – 76 GHz, low/middle/high frequency

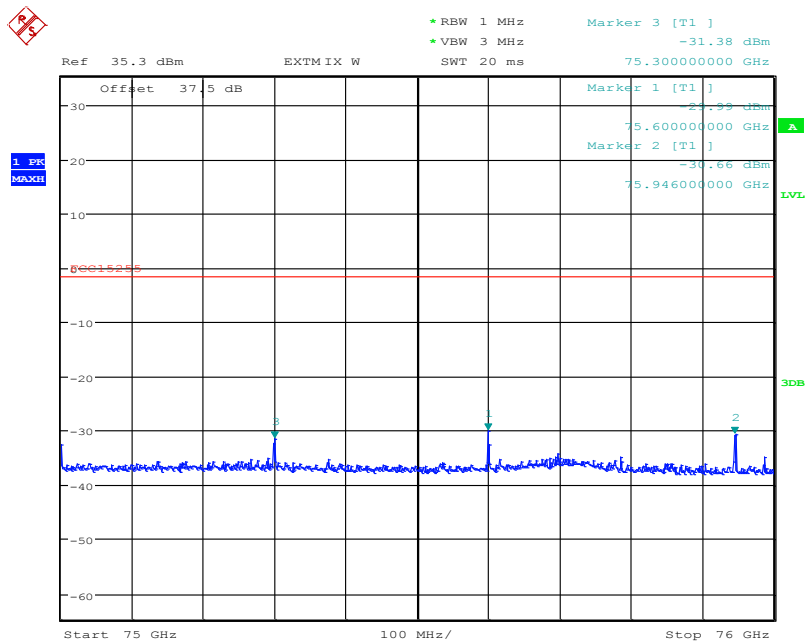

Date: 23.AUG.2016 17:40:54

Plot 37: Sample 1, spurious emissions, 77 GHz - 110 GHz, low/middle/high frequency

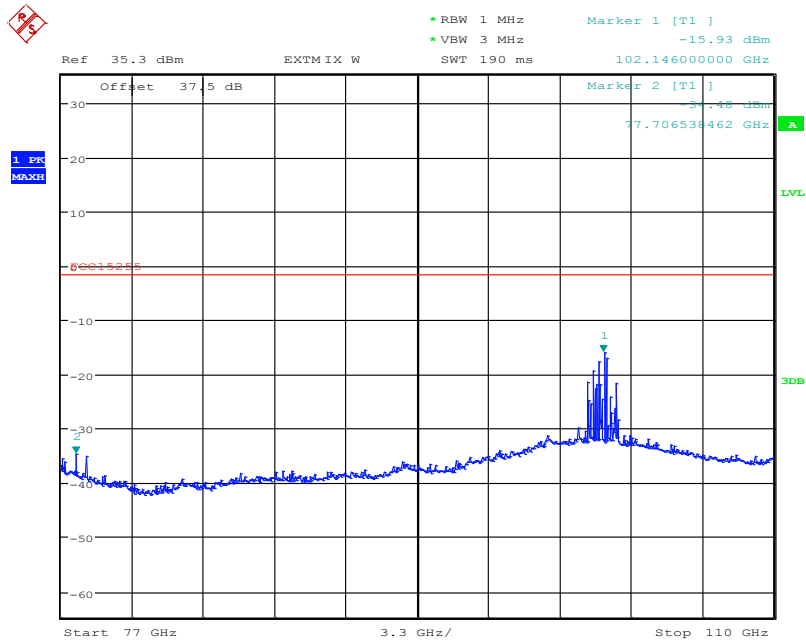

Date: 23.AUG.2016 17:43:38

Plot 38: Sample 1, spurious emissions, 110 GHz – 170 GHz, low/middle/high frequency

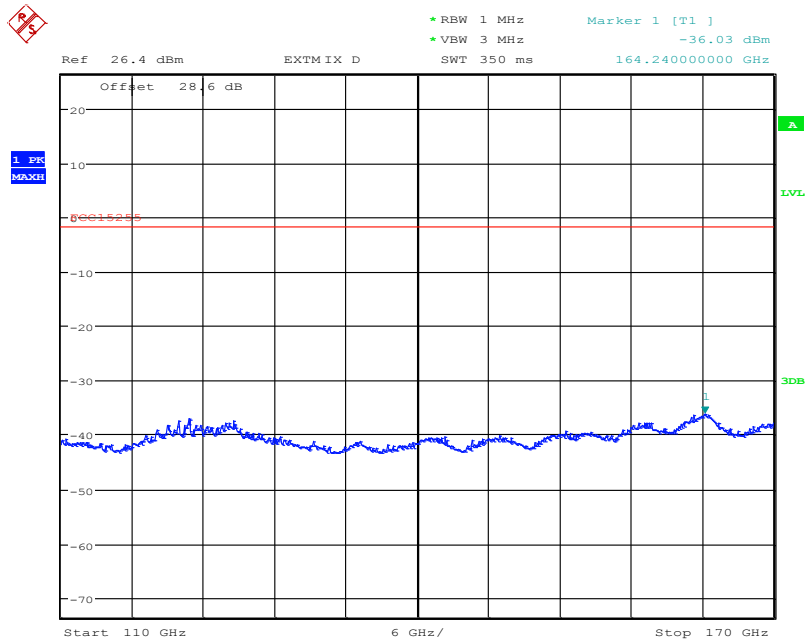

Date: 23.AUG.2016 18:13:05

Plot 39: Sample 1, spurious emissions, 170 GHz – 220 GHz, low/middle/high frequency

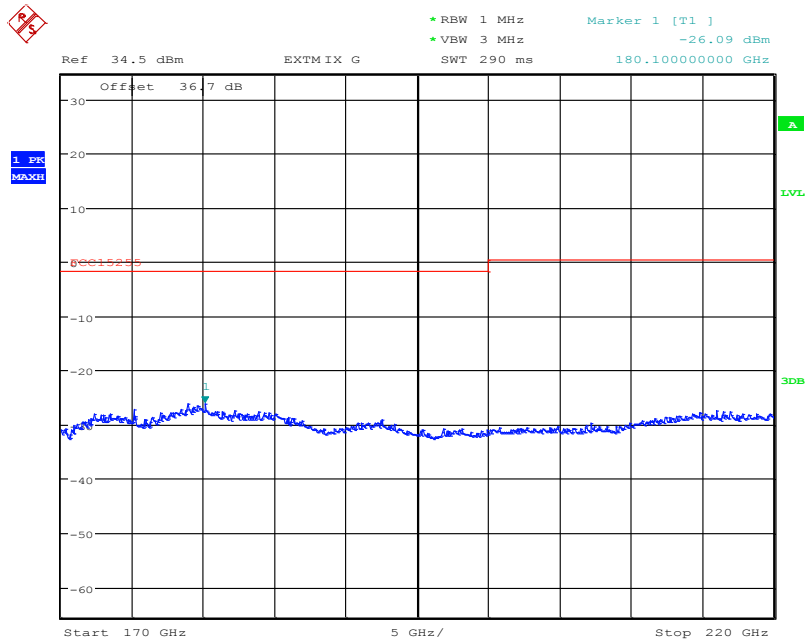

Date: 23.AUG.2016 18:18:57

Plot 40: Sample 1, spurious emissions, 220 GHz – 235 GHz, low/middle/high frequency

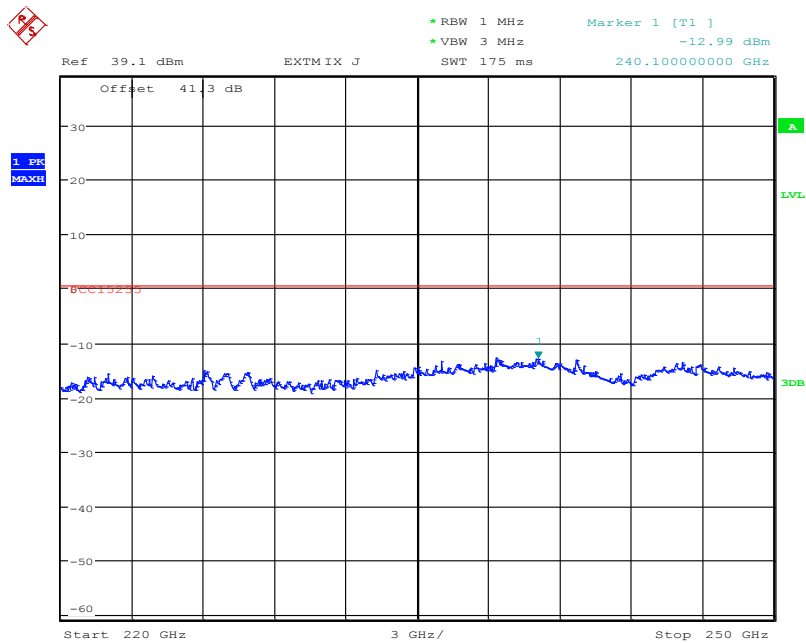

Date: 23.AUG.2016 18:20:21

Plot 41: Sample 6, spurious emissions, 9 kHz – 30 MHz, low frequency

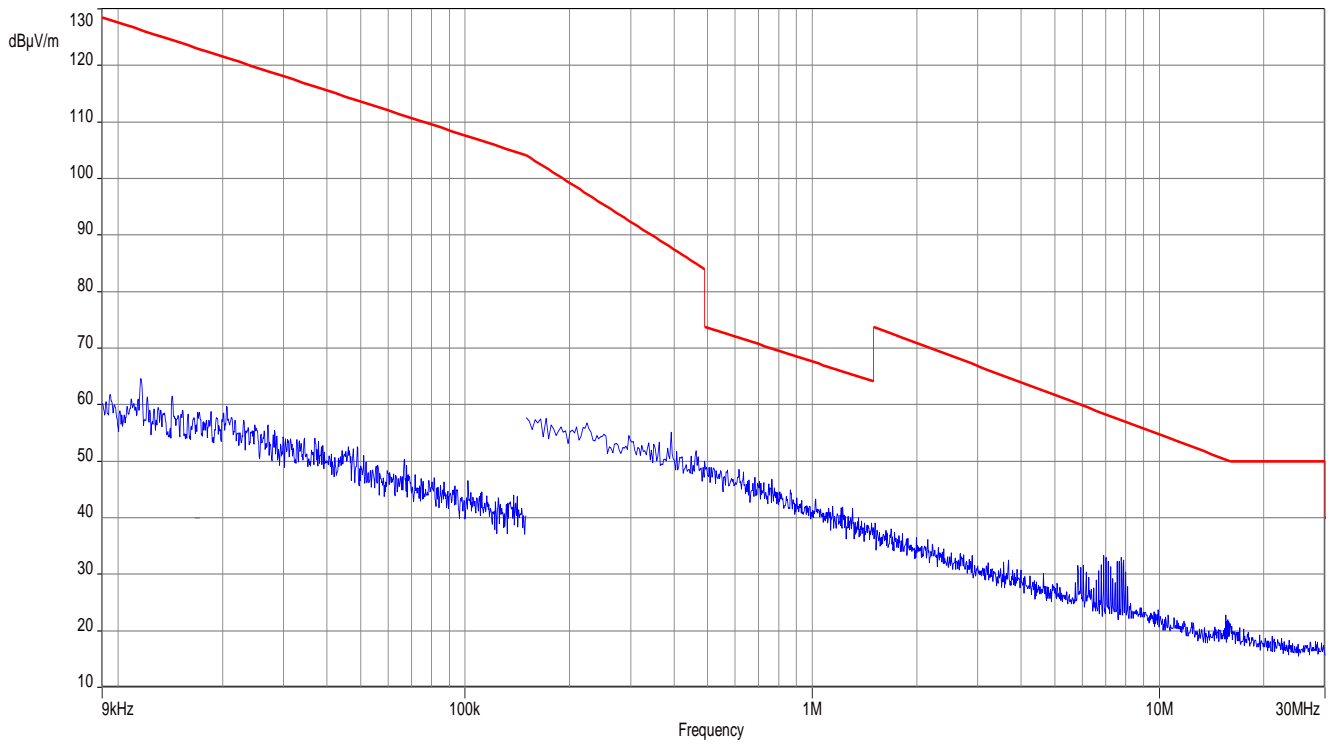

Plot 42: Sample 6, spurious emissions, 9 kHz – 30 MHz, middle frequency

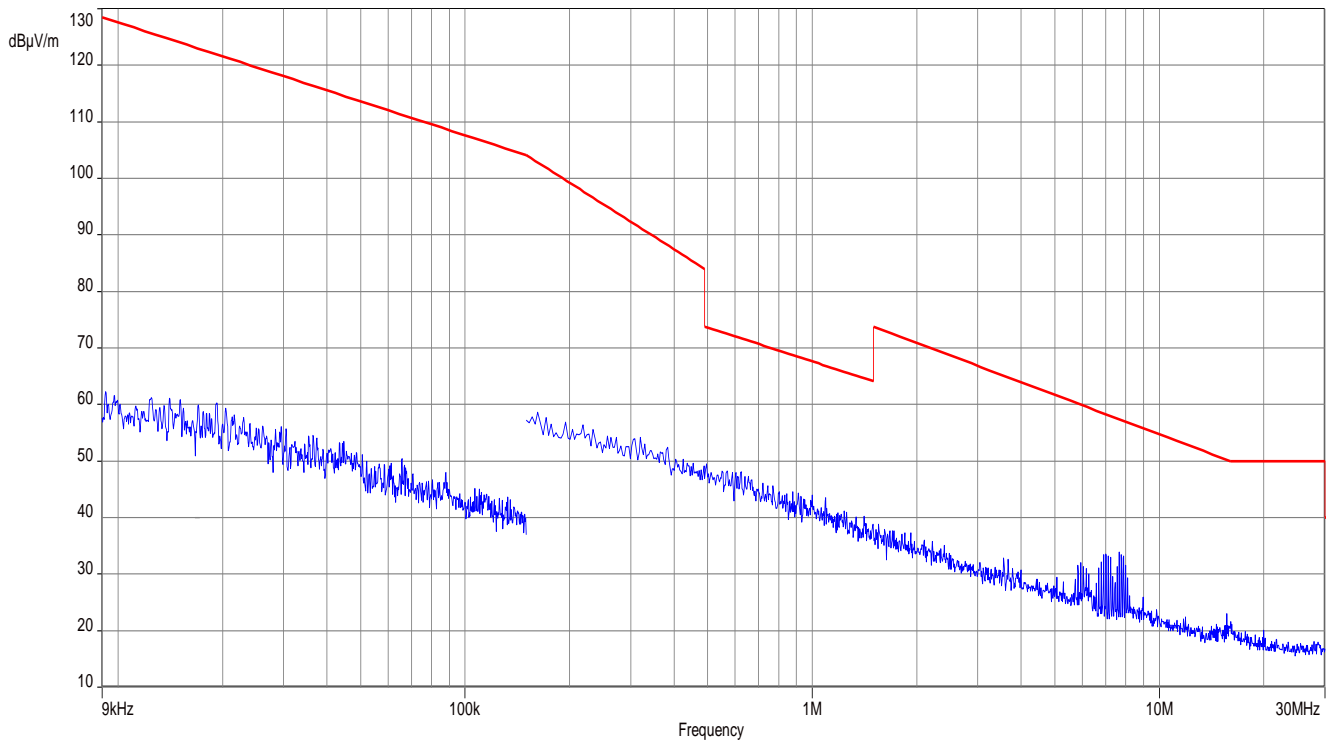

Plot 43: Sample 6, spurious emissions, 9 kHz – 30 MHz, high frequency

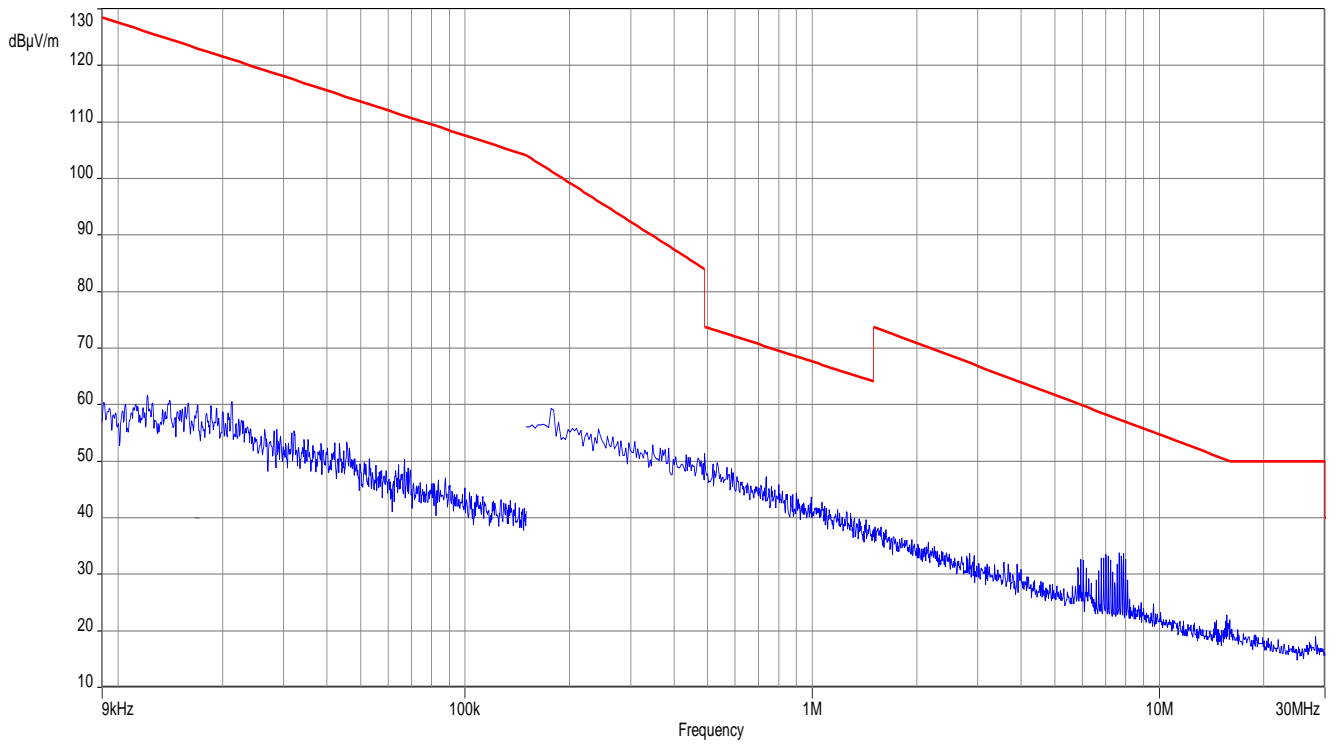

Plot 44: Sample 6, spurious emissions, 30 MHz – 1 GHz, low frequency

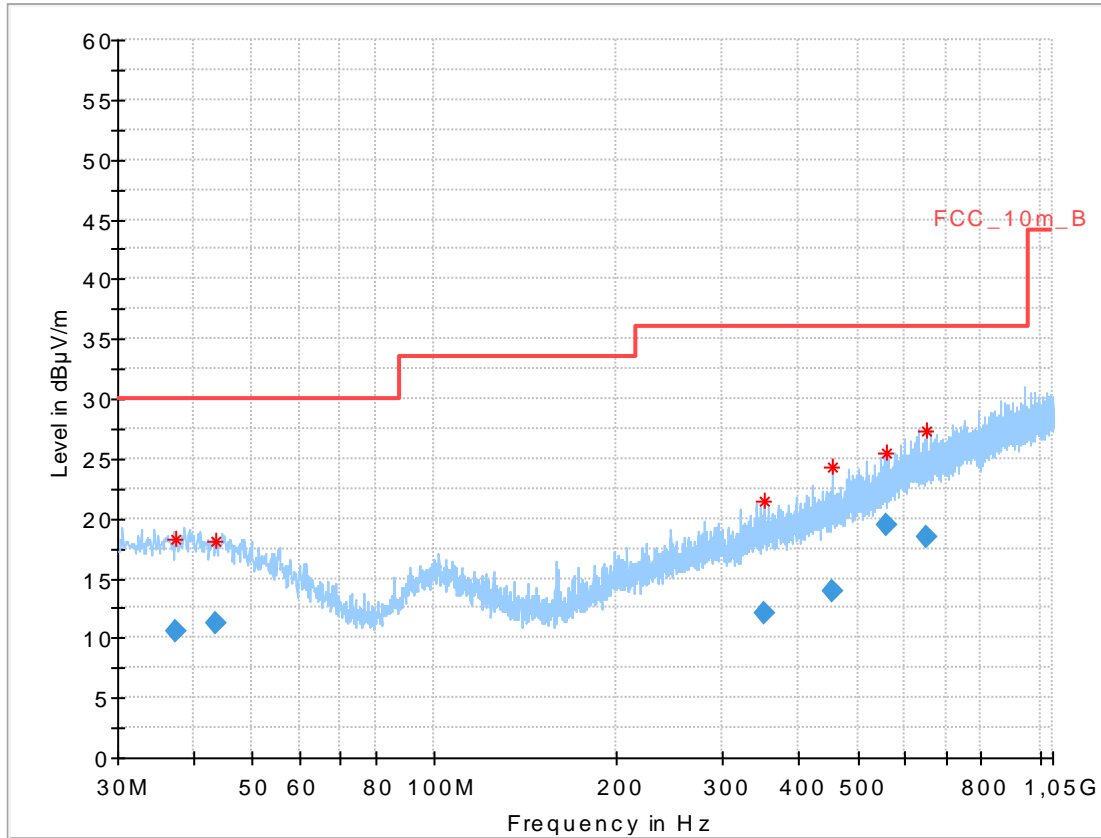

Frequency (MHz)	QuasiPeak (dBµV/m)	Limit (dBµV/m)	Margin (dB)	Meas. Time (ms)	Bandwidth (kHz)	Height (cm)	Pol	Azimuth (deg)	Corr. (dB)
37.539600	10.55	30.00	19.45	1000.0	120.000	177.0	V	276.0	13.9
43.476900	11.27	30.00	18.73	1000.0	120.000	102.0	V	232.0	13.9
350.029500	12.05	36.00	23.95	1000.0	120.000	400.0	H	232.0	16.0
453.254550	13.86	36.00	22.14	1000.0	120.000	400.0	V	320.0	17.7
560.035200	19.46	36.00	16.54	1000.0	120.000	174.0	H	320.0	19.6
651.608400	18.36	36.00	17.64	1000.0	120.000	100.0	H	266.0	21.1

Plot 45: Sample 6, spurious emissions, 30 MHz – 1 GHz, middle frequency

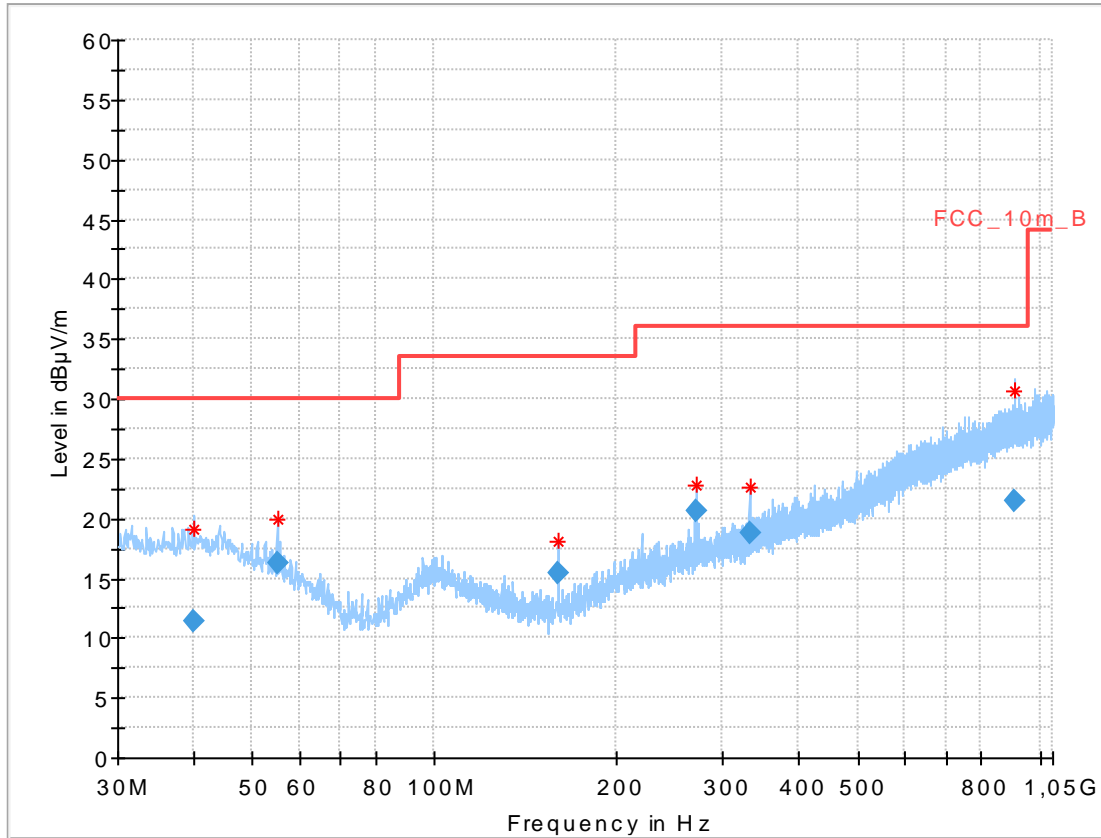

Frequency (MHz)	QuasiPeak (dBµV/m)	Limit (dBµV/m)	Margin (dB)	Meas. Time (ms)	Bandwidth (kHz)	Height (cm)	Pol	Azimuth (deg)	Corr. (dB)
40.046550	11.48	30.00	18.52	1000.0	120.000	200.0	V	266.0	14.0
54.999150	16.34	30.00	13.66	1000.0	120.000	271.0	V	5.0	11.8
159.997950	15.37	33.50	18.13	1000.0	120.000	100.0	V	-13.0	9.1
271.154100	20.57	36.00	15.43	1000.0	120.000	102.0	V	276.0	13.8
331.405950	18.73	36.00	17.27	1000.0	120.000	101.0	V	231.0	15.5
908.789700	21.42	36.00	14.58	1000.0	120.000	400.0	V	95.0	24.1

Plot 46: Sample 6, spurious emissions, 30 MHz – 1 GHz, high frequency

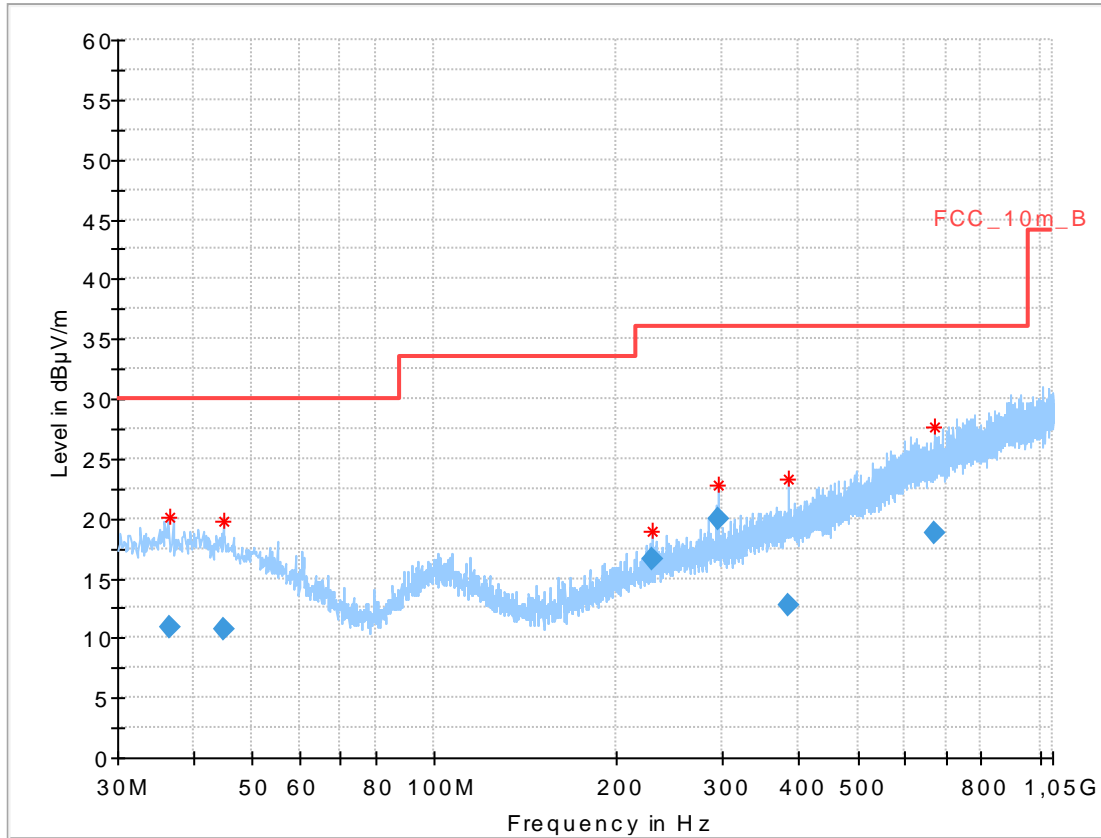

Frequency (MHz)	QuasiPeak (dBµV/m)	Limit (dBµV/m)	Margin (dB)	Meas. Time (ms)	Bandwidth (kHz)	Height (cm)	Pol	Azimuth (deg)	Corr. (dB)
36.621600	10.92	30.00	19.08	1000.0	120.000	200.0	V	7.0	13.9
44.984250	10.76	30.00	19.24	1000.0	120.000	103.0	H	160.0	13.9
228.419700	16.52	36.00	19.48	1000.0	120.000	98.0	V	161.0	12.7
293.651250	20.01	36.00	15.99	1000.0	120.000	100.0	V	233.0	14.3
384.199500	12.67	36.00	23.33	1000.0	120.000	200.0	V	141.0	16.6
671.641200	18.71	36.00	17.29	1000.0	120.000	400.0	H	320.0	21.3

Plot 47: Sample 6, spurious emissions, 1 GHz – 7 GHz, low frequency

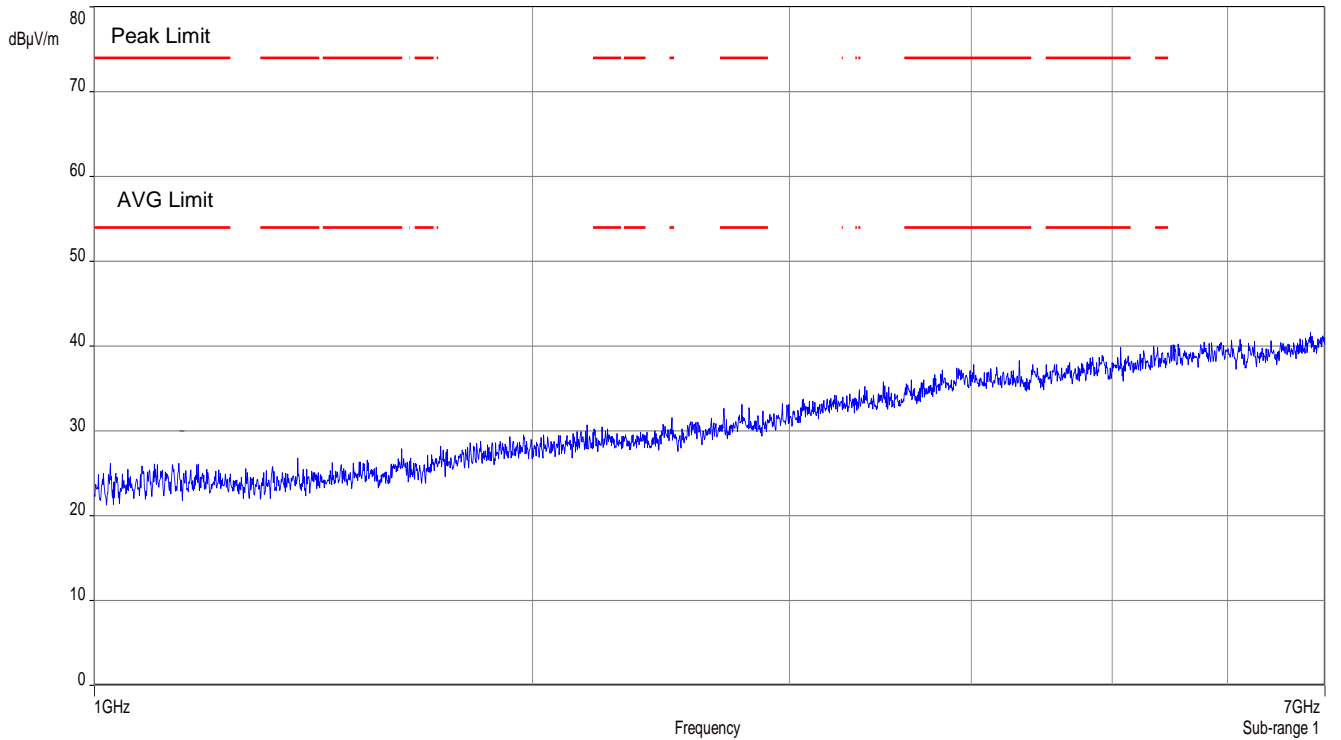

Plot 48: Sample 6, spurious emissions, 1 GHz – 7 GHz, middle frequency

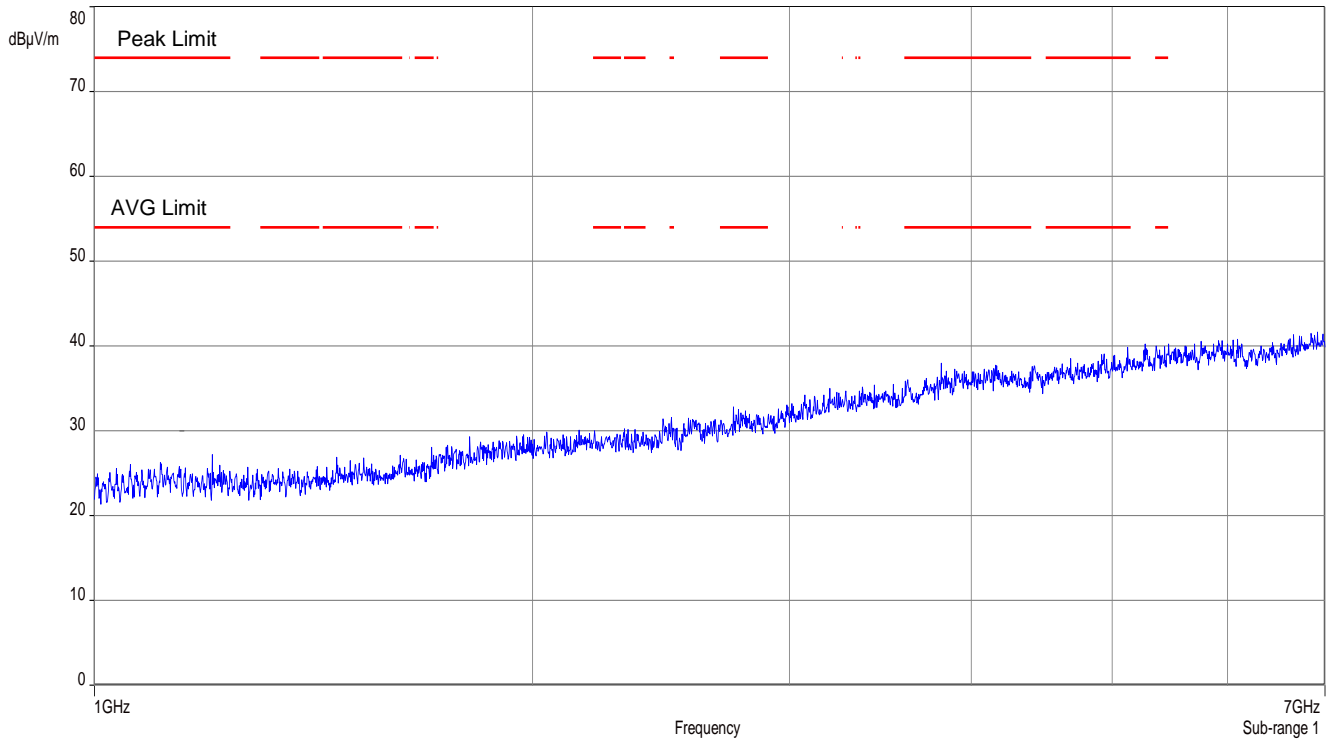

Plot 49: Sample 6, spurious emissions, 1 GHz – 7 GHz, high frequency

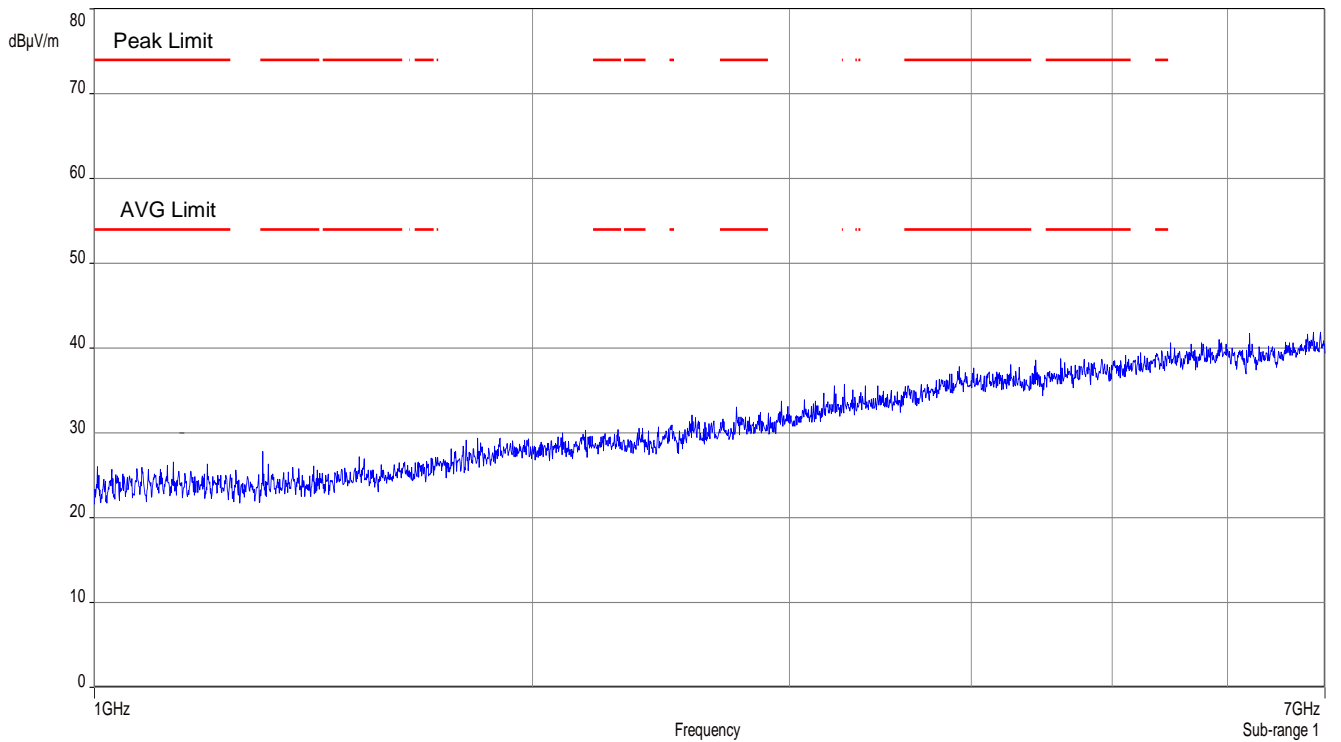

Plot 50: Sample 6, spurious emissions, 7 GHz – 12.75 GHz, low frequency

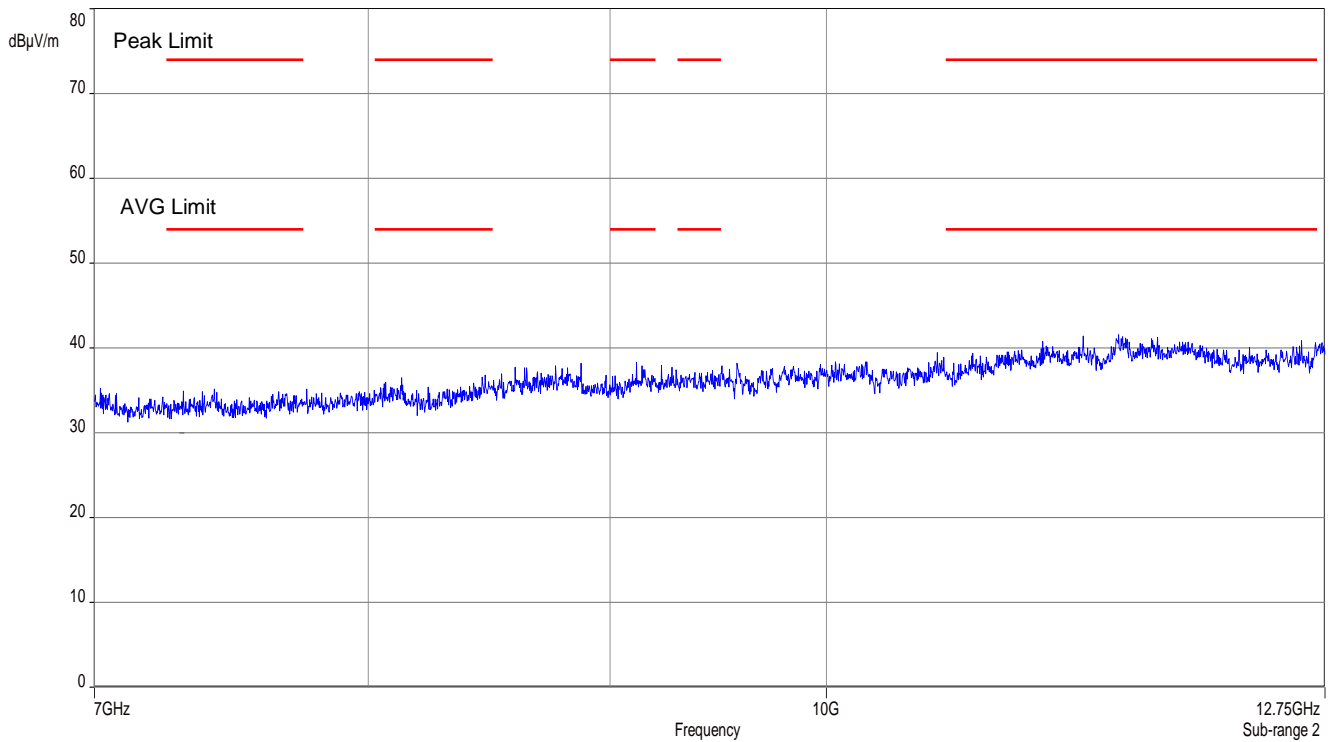

Plot 51: Sample 6, spurious emissions, 7 GHz – 12.75 GHz, middle frequency

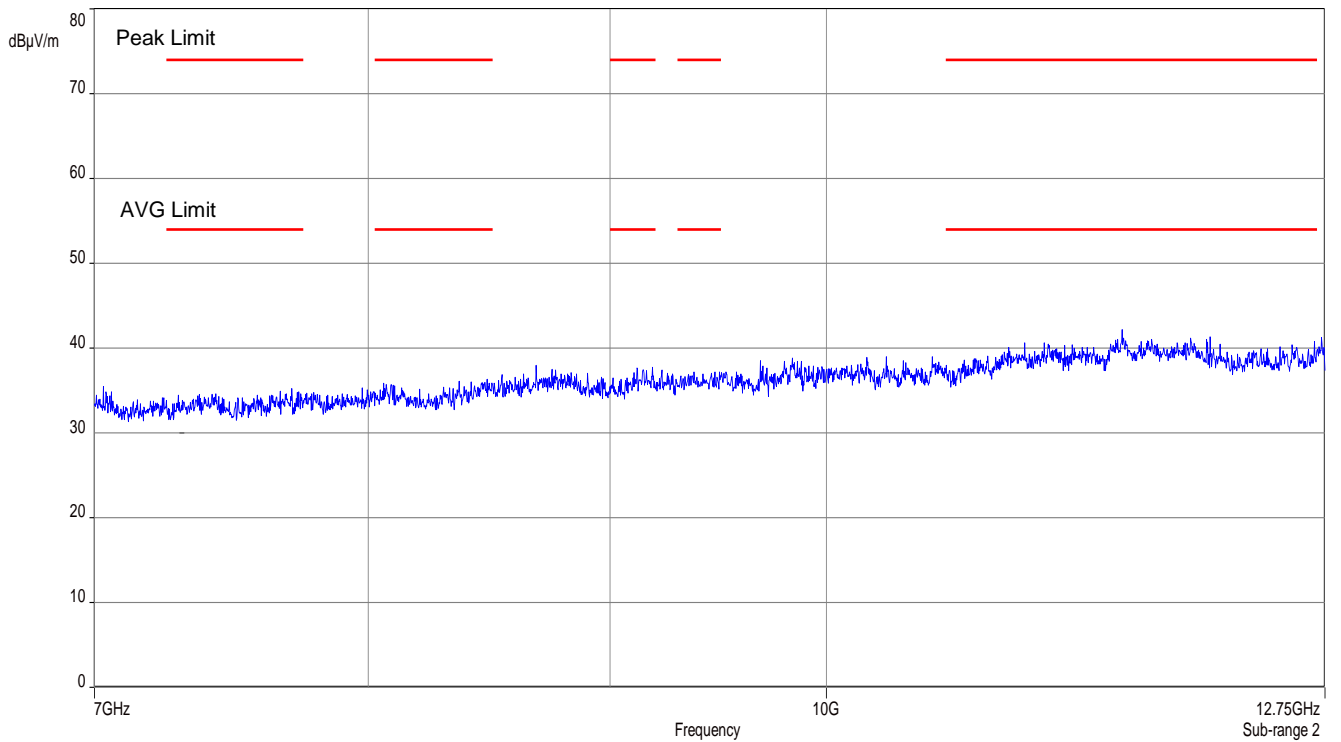

Plot 52: Sample 6, spurious emissions, 7 GHz – 12.75 GHz, high frequency

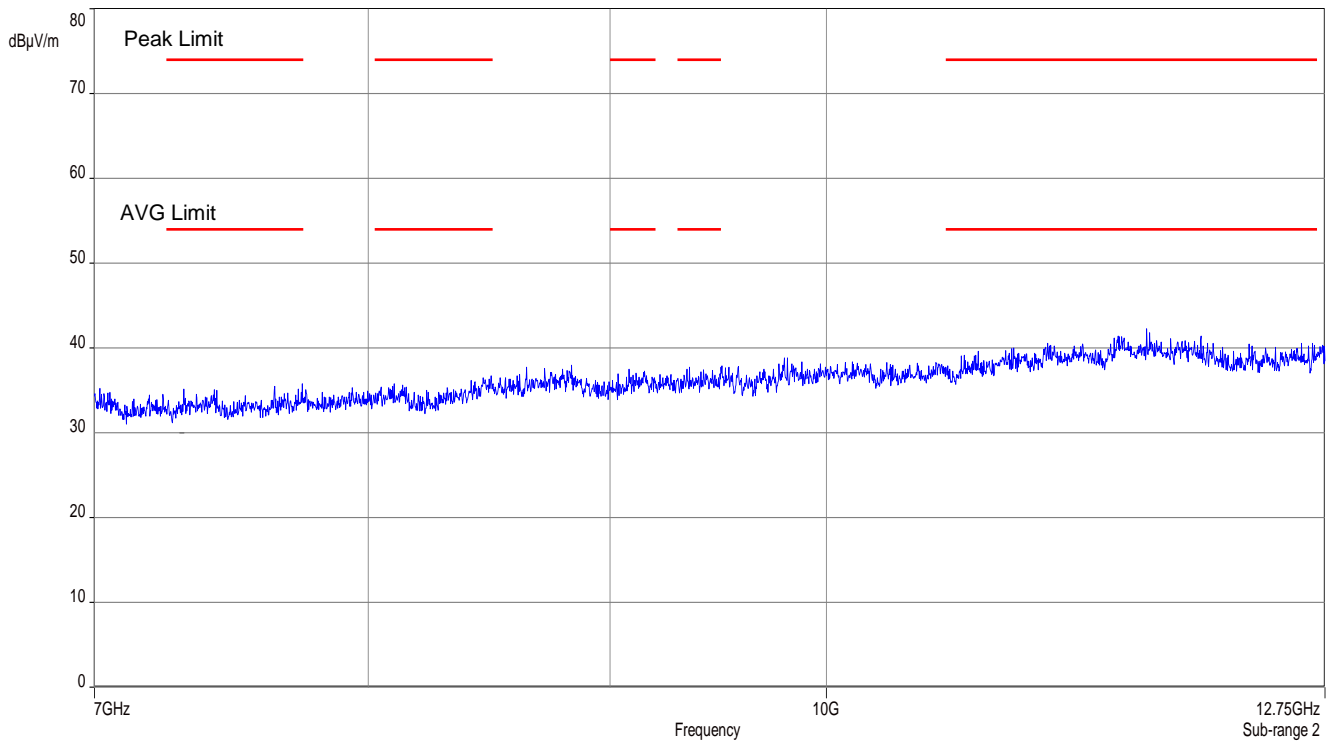

Plot 53: Sample 6, spurious emissions, 12.75 GHz – 18 GHz, low/middle/high frequency

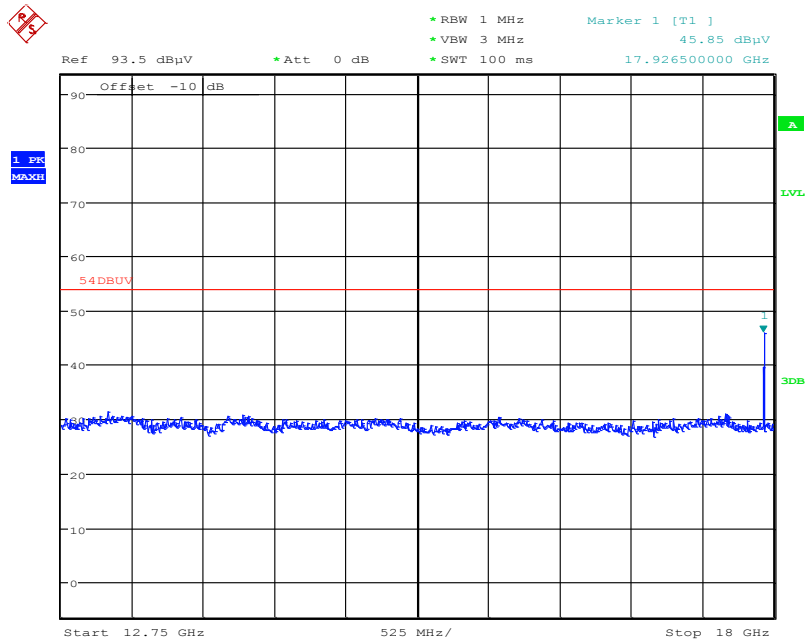

Date: 24.AUG.2016 11:22:30

Plot 54: Sample 6, spurious emissions, 18 GHz – 26.5 GHz, low/middle/high frequency

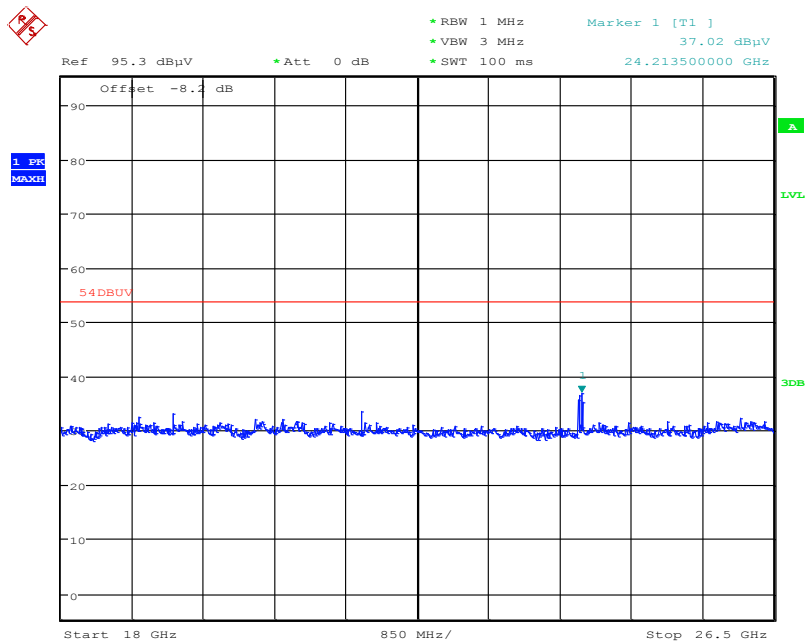

Date: 24.AUG.2016 11:20:06

Plot 55: Sample 6, spurious emissions, 26.5 GHz – 40 GHz, low/middle/high frequency

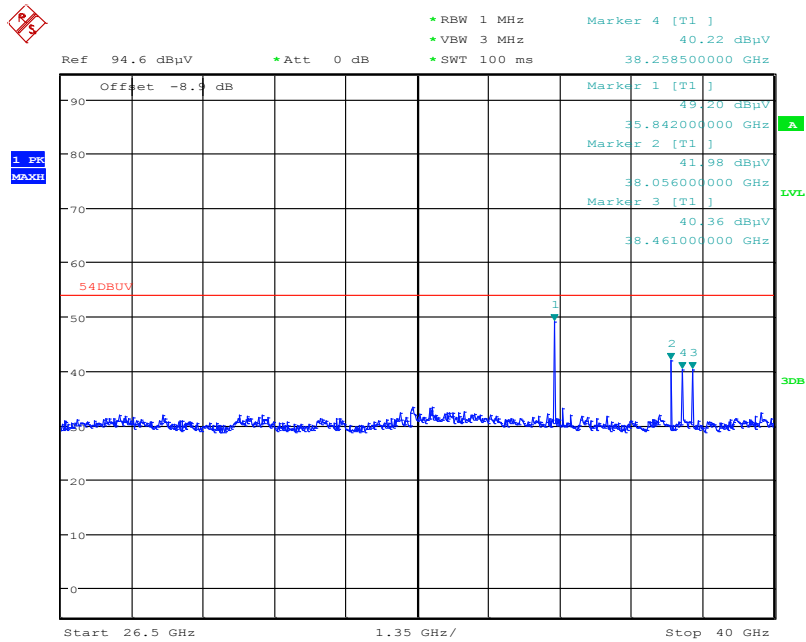

Date: 24.AUG.2016 11:11:13

Marker shows the peak value (limit @ 74 dBuV)

Plot 56: Sample 6, spurious emissions, 40 GHz – 50 GHz, low/middle/high frequency

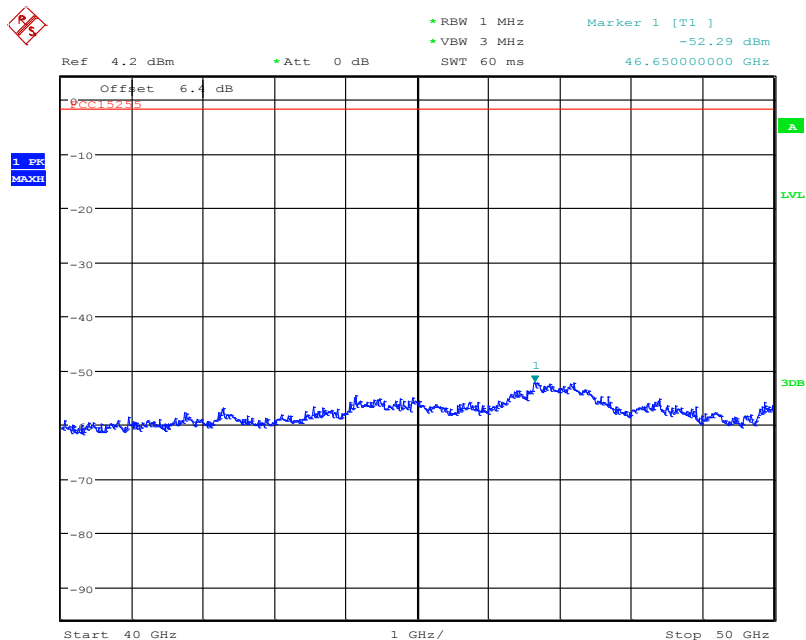

Date: 24.AUG.2016 10:52:28

Plot 57: Sample 6, spurious emissions, 50 GHz – 75 GHz, low/middle/high frequency

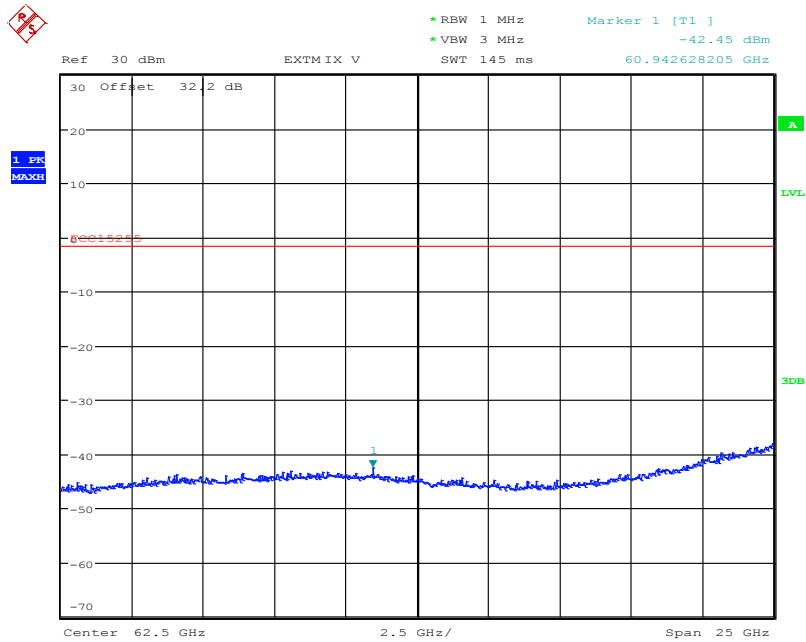

Date: 24.AUG.2016 10:29:20

Plot 58: Sample 6, spurious emissions, 75 GHz – 76 GHz, low/middle/high frequency

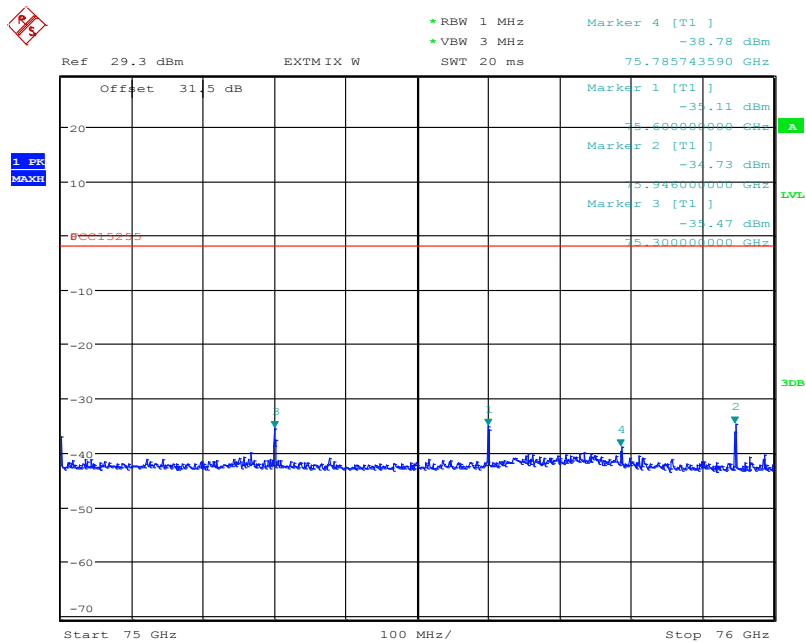

Date: 24.AUG.2016 09:55:50

Plot 59: Sample 6, spurious emissions, 77 GHz - 110 GHz, low/middle/high frequency

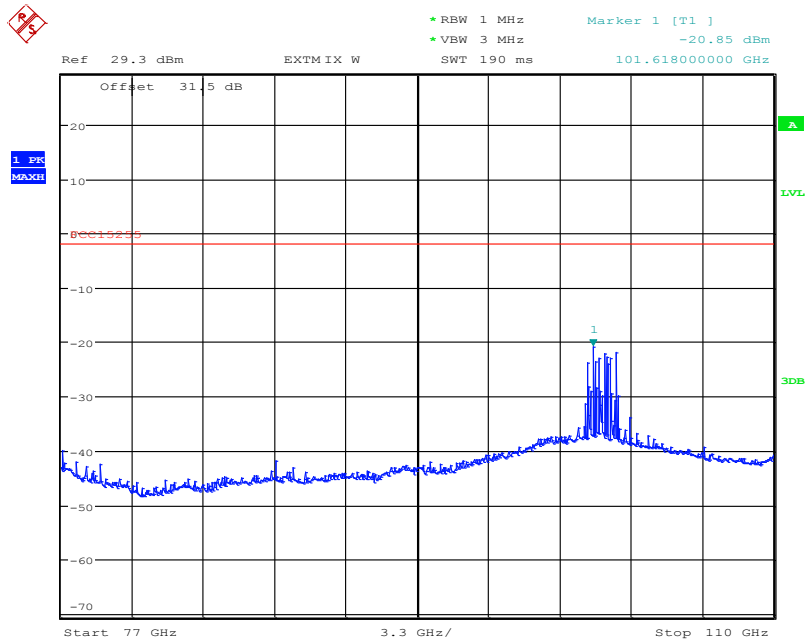

Date: 24.AUG.2016 09:51:53

Plot 60: Sample 6, spurious emissions, 110 GHz – 170 GHz, low/middle/high frequency

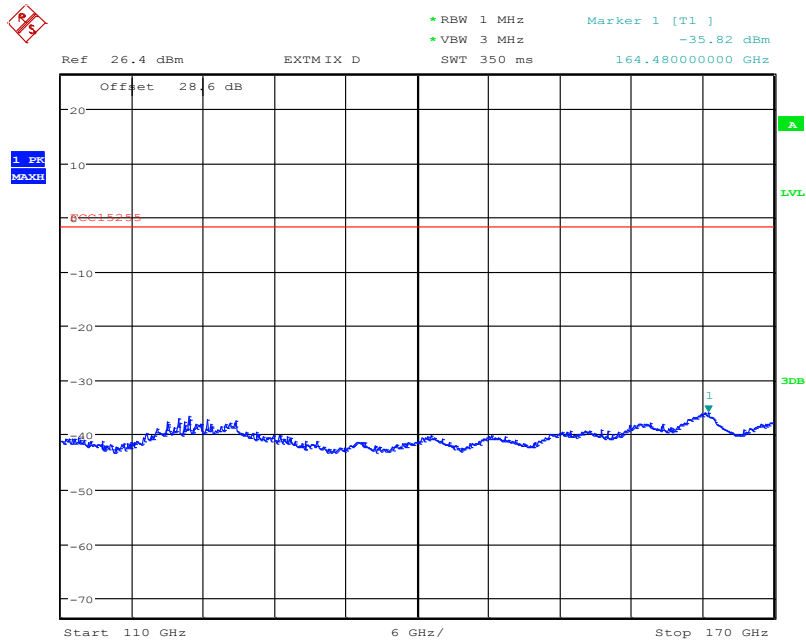

Date: 24.AUG.2016 09:20:28

Plot 61: Sample 6, spurious emissions, 170 GHz – 220 GHz, low/middle/high frequency

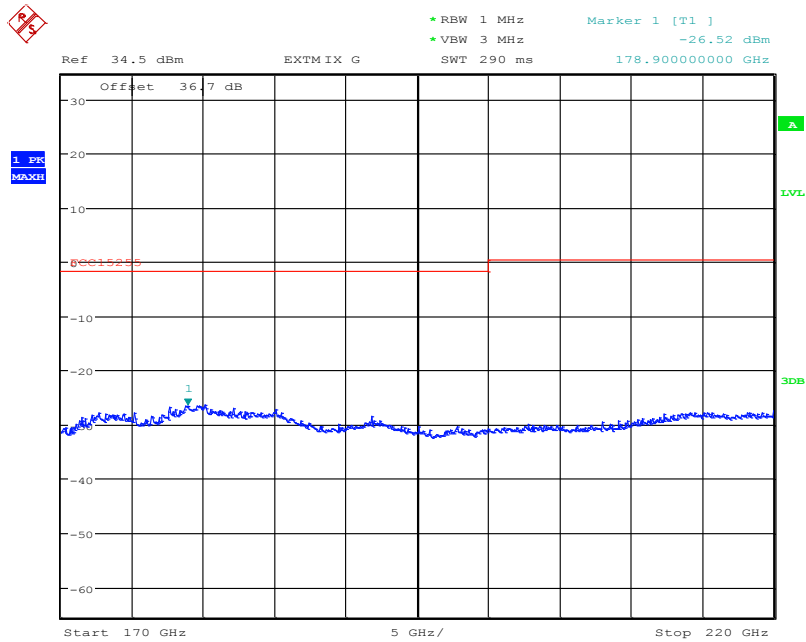

Date: 24.AUG.2016 09:07:47

Plot 62: Sample 6, spurious emissions, 220 GHz – 235 GHz, low/middle/high frequency

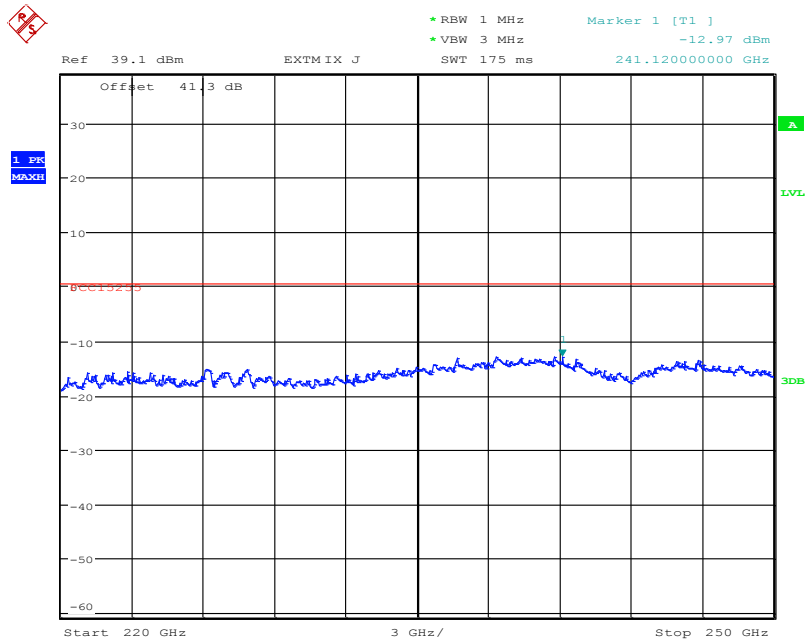

Date: 24.AUG.2016 09:02:46

10.5 Frequency stability

Low Channel:

TEST CONDITIONS	Frequency stability [GHz]
T_{nom} / V_{nom}	76.104 000
$T_{min} / V_{min}-V_{max}$	76.106 000
$T_{max} / V_{min}-V_{max}$	76.108 000

Middle Channel:

TEST CONDITIONS	Frequency stability [GHz]
T_{nom} / V_{nom}	76.506 000
$T_{min} / V_{min}-V_{max}$	76.506 000
$T_{max} / V_{min}-V_{max}$	76.508 000

High Channel:

TEST CONDITIONS	Frequency stability [GHz]
T_{nom} / V_{nom}	76.906 000
$T_{min} / V_{min}-V_{max}$	76.908 000
$T_{max} / V_{min}-V_{max}$	76.910 000

Limits:

FCC §95.3379 (b)

Frequency range	$f(\text{lowest}) > 76.0 \text{ GHz}$	$f(\text{highest}) < 81.0 \text{ GHz}$
-----------------	---------------------------------------	--

Limits:

RSS-251 (5.2.2) / (5.4)

Frequency range	$f(\text{lowest}) > 76.0 \text{ GHz}$	$f(\text{highest}) < 77.0 \text{ GHz}$
-----------------	---------------------------------------	--

Verdict: Complies

11 Observations

No observations except those reported with the single test cases have been made.

12 Document history

Version	Applied changes	Date of release
	Initial release – DRAFT	2016-09-07
	Final - FCC ID and ISED registration number added	2016-10-28
-A	Part 95 updated	2017-11-20

13 Glossary

Glossary

AVG	-	Average
DUT	-	Device under test
EMC	-	Electromagnetic Compatibility
EN	-	European Standard
EUT	-	Equipment under test
ETSI	-	European Telecommunications Standard Institute
FCC	-	Federal Communication Commission
FCC ID	-	Company Identifier at FCC
HW	-	Hardware
IC	-	Industry Canada
Inv. No.	-	Inventory number
N/A	-	Not applicable
PP	-	Positive peak
QP	-	Quasi peak
S/N	-	Serial number
SW	-	Software
PMN	-	Product marketing name
HMN	-	Host marketing name
HVIN	-	Hardware version identification number
FVIN	-	Firmware version identification number

14 Accreditation Certificate

first page	last page			
 <p>Deutsche Akkreditierungsstelle GmbH</p> <p>Entrusted according to Section 8 subsection 1 AkkStelleG in connection with Section 1 subsection 1 AkkStelleGBV Signatory to the Multilateral Agreements of EA, ILAC and IAF for Mutual Recognition</p>  <p>Accreditation</p> <p>The Deutsche Akkreditierungsstelle GmbH attests that the testing laboratory CTC advanced GmbH Untertürkheimer Straße 6-10, 66117 Saarbrücken</p> <p>is competent under the terms of DIN EN ISO/IEC 17025:2005 to carry out tests in the following fields: Telecommunication</p> <p>The accreditation certificate shall only apply in connection with the notice of accreditation of 02.06.2017 with the accreditation number D-PL-12076-01 and is valid until 21.04.2021. It comprises the cover sheet, the reverse side of the cover sheet and the following annex with a total of 43 pages.</p> <p>Registration number of the certificate: D-PL-12076-01-03</p> <p>Frankfurt, 02.06.2017</p>  Dipl.-Ing. (FH) Ralf Beyer Head of Division <p><small>See notes on back.</small></p>	<p>Deutsche Akkreditierungsstelle GmbH</p> <table border="0"> <tr> <td>Office Berlin Spittelmarkt 10 10117 Berlin</td> <td>Office Frankfurt am Main Europa-Allee 52 60327 Frankfurt am Main</td> <td>Office Braunschweig Bundesallee 100 38116 Braunschweig</td> </tr> </table> <p>The publication of extracts of the accreditation certificate is subject to the prior written approval by Deutsche Akkreditierungsstelle GmbH (DAkkS). Exempted is the unchanged form of separate disseminations of the cover sheet by the conformity assessment body mentioned overleaf.</p> <p>No impression shall be made that the accreditation also extends to fields beyond the scope of accreditation attested by DAkkS.</p> <p>The accreditation was granted pursuant to the Act on the Accreditation Body (AkkStelleG) of 31 July 2009 (Federal Law Gazette I p. 2625) and the Regulation (EC) No 765/2008 of the European Parliament and of the Council of 9 July 2008 setting out the requirements for accreditation and market surveillance relating to the marketing of products (Official Journal of the European Union L 218 of 9 July 2008, p. 30). DAkkS is a signatory to the Multilateral Agreements for Mutual Recognition of the European co-operation for Accreditation (EA), International Accreditation Forum (IAF) and International Laboratory Accreditation Cooperation (ILAC). The signatories to these agreements recognise each other's accreditations.</p> <p>The up-to-date state of membership can be retrieved from the following websites: EA: www.european-accreditation.org ILAC: www.ilac.org IAF: www.iaf.nu</p>	Office Berlin Spittelmarkt 10 10117 Berlin	Office Frankfurt am Main Europa-Allee 52 60327 Frankfurt am Main	Office Braunschweig Bundesallee 100 38116 Braunschweig
Office Berlin Spittelmarkt 10 10117 Berlin	Office Frankfurt am Main Europa-Allee 52 60327 Frankfurt am Main	Office Braunschweig Bundesallee 100 38116 Braunschweig		

Note: The current certificate annex is published on the website (link see below) of the Accreditation Body DAkkS or may be received by CTC advanced GmbH on request

<http://www.dakks.de/as/ast/d/D-PL-12076-01-03.pdf>