

DWN	OK	APP	TITLE	Confidentiality: C-S02 Availability: A-S01
NAME	Schmid	Schneider	MRR1corner CP2 C1	
DATE	15.12.2015		Radar-LP	
Plot Date	16/03/22	Plot Variant Name	uC-Power/BB-Verbinder	
Plot Time	09:20:09	Variation Comment		
Q-1g. DIN	ROBERT BOSCH	Partlist No.	NO. 0265C64137_01	ECAD No. Board No.
A 2	STUTTGART			
TopLevelNo.		TopLevelTitel		

**BtoB Connector X500**

Versorgungen  
PS-V5-DIG  
PS-V5-LN  
PS-V3-DIG  
PS-V3-ANA  
PS-VCORE

GND-Flaechen  
GNDu  
GNDg  
GNDf

Umlaufendes Masseband = GNDf

Uebergangswiderstand des B2B-Verbinders: 80 mOhm pro Steckerpaar

© Robert Bosch GmbH. All rights reserved. Also regarding any disposal, exploitation, reproduction, editing, distributing, as well as in the event of applications for industrial property rights.

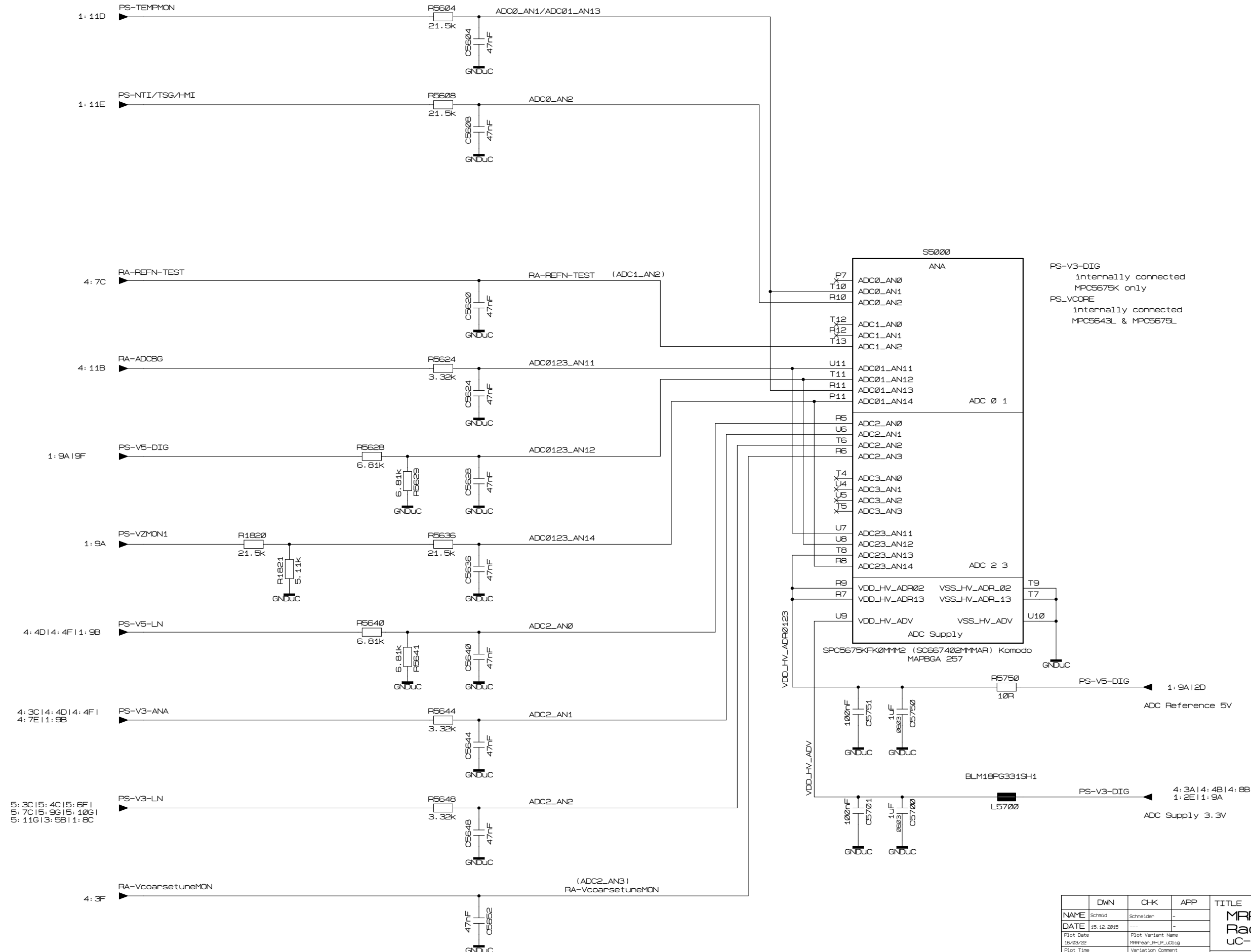

PS-V3-DIG  
internally connected  
MPC5675K only  
PS\_VCORE  
internally connected  
MPC5643L & MPC5675L

NAME	Schmid	Schneider	-	TITLE <b>MRR1corner CP2 C1 Radar-LP uC-analog</b>	Confidentiality: C-S02 Availability: A-S01
DATE	15.12.2015	---	---		
Plot Date	16/03/22	Plot Variant Name MRRnear_LP_uCbig		Partlist No. - ECAP No. -	
Plot Time	09:20:10	Variation Comment -			
Org. DIN A 2	ROBERT BOSCH STUTT GART		Doc-No. @dano NO.	Board No. @bared	2 of 5
TopLevelNo.	-		TopLevelTitel	-	

Nexus Connector  
X700

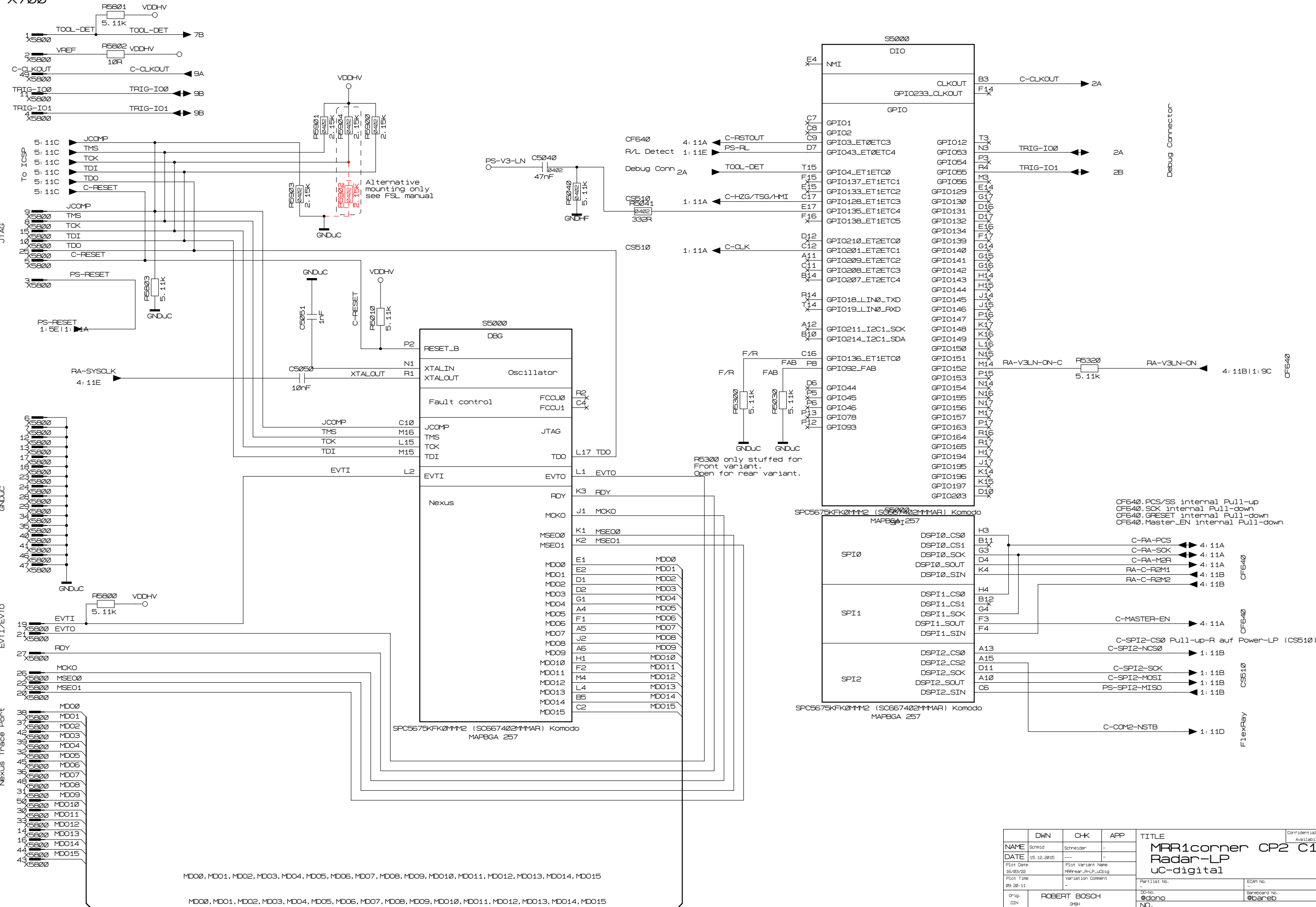

DWN	OK	APP	TITLE	Confidentiality: C-S02
NAME	Schmid	Schneider	MRR1corner CP2 C1	Availability: A-SC1
DATE	15.12.2015	---	Radar-LP	
Plot Date	16/03/22	MRRnear_LP_LCbig	uC-digital	
Plot Time	09:20:11	Variation Comment	Partlist No.	ECAP No.
Q-1g.	ROBERT BOSCH		@dono	Board No.
QIN	STUTT GART		@bano	
A 2			NO.	
			0265C64137_01	
TopLevel.No.	-		TopLevel.Titel	3 of 5

© Robert Bosch GmbH. All rights reserved. Also regarding any disposal, exploitation, reproduction, editing, distributing, as well as in the event of applications for industrial property rights.

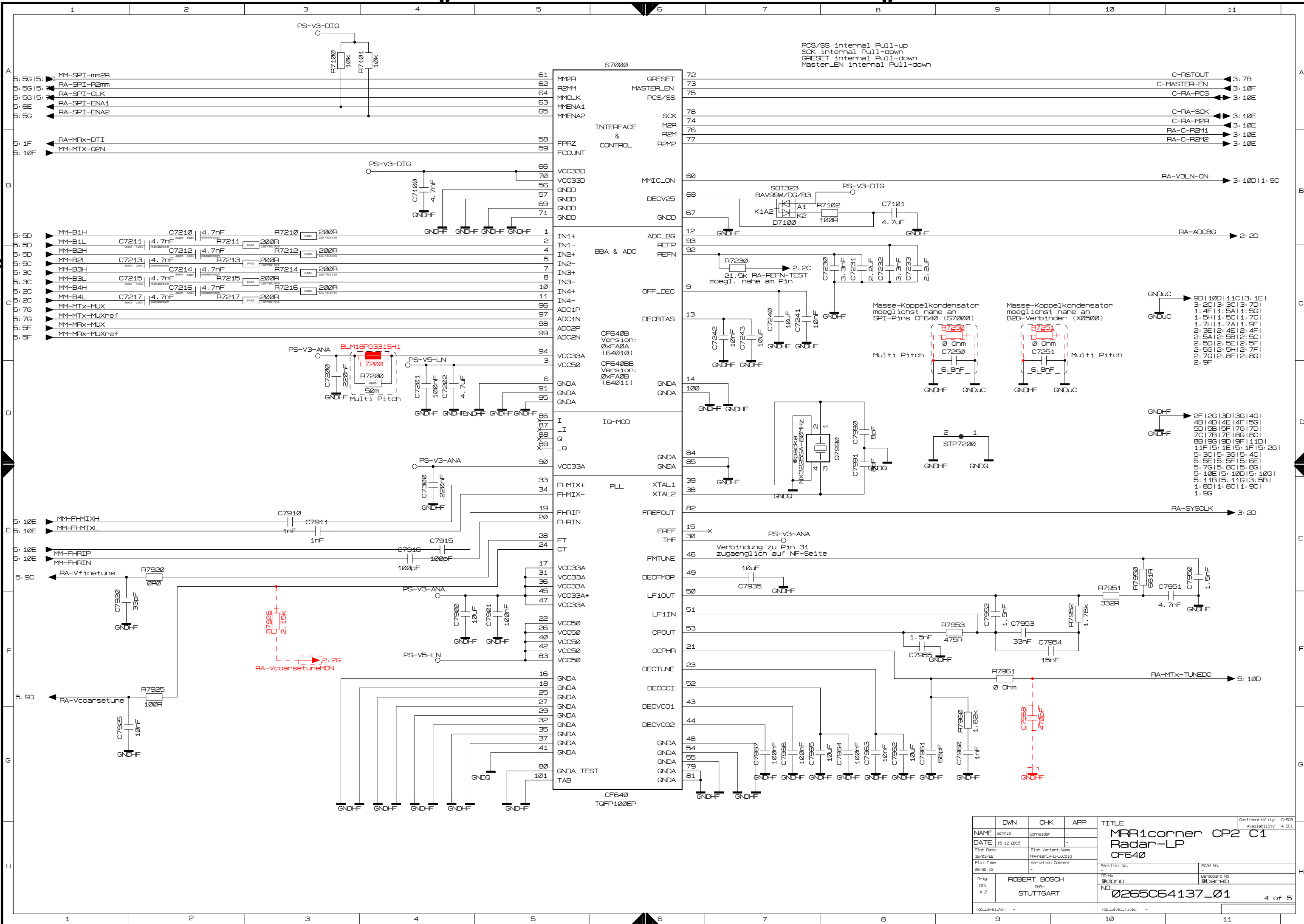

NAME	DWN	CHK	APP	TITLE	Confidentiality
Schmid		Schneider	-	MRR1corner CP2 C1 Radar-LP CF640	C-S02 A-S01
DATE	15.12.2015	---	---		
Plot Date	16/03/22		Plot Variant Name	MRR1corner_LP_LCbig	
Plot Time	09:20:12		Variation Comment		
Q-1g, DIN A 2	ROBERT BOSCH STUTTGART	gsh		Partlist No. @dono NO. 0265C64137_01	ECAP No. - Board No. @bancb
TopLevelNo.	-			TopLevelTitel	4 of 5

Alle aussenliegenden Anschlüsse der eWLBs beim Layouten anschliessen

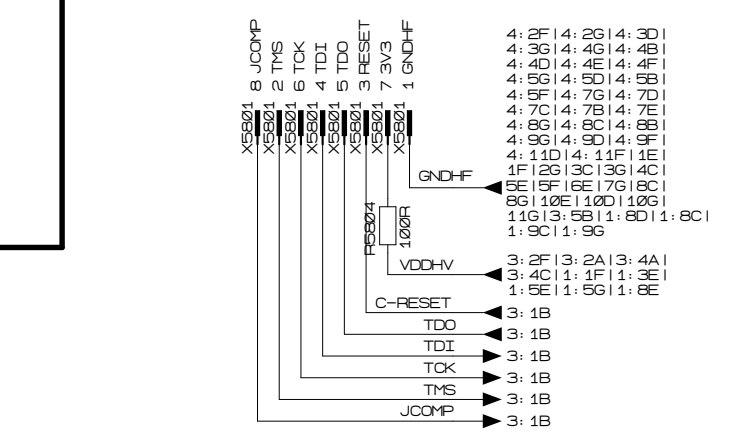
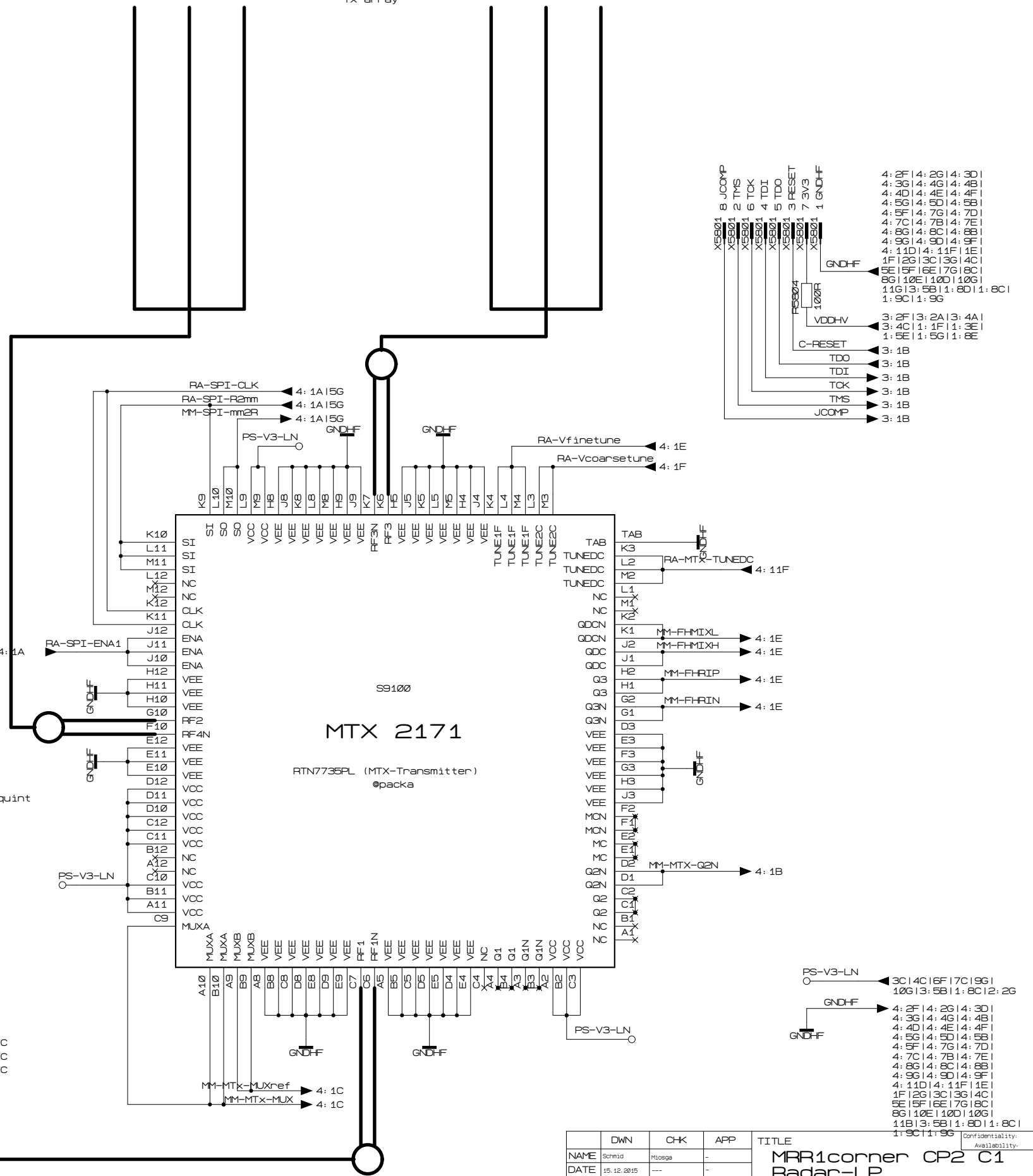
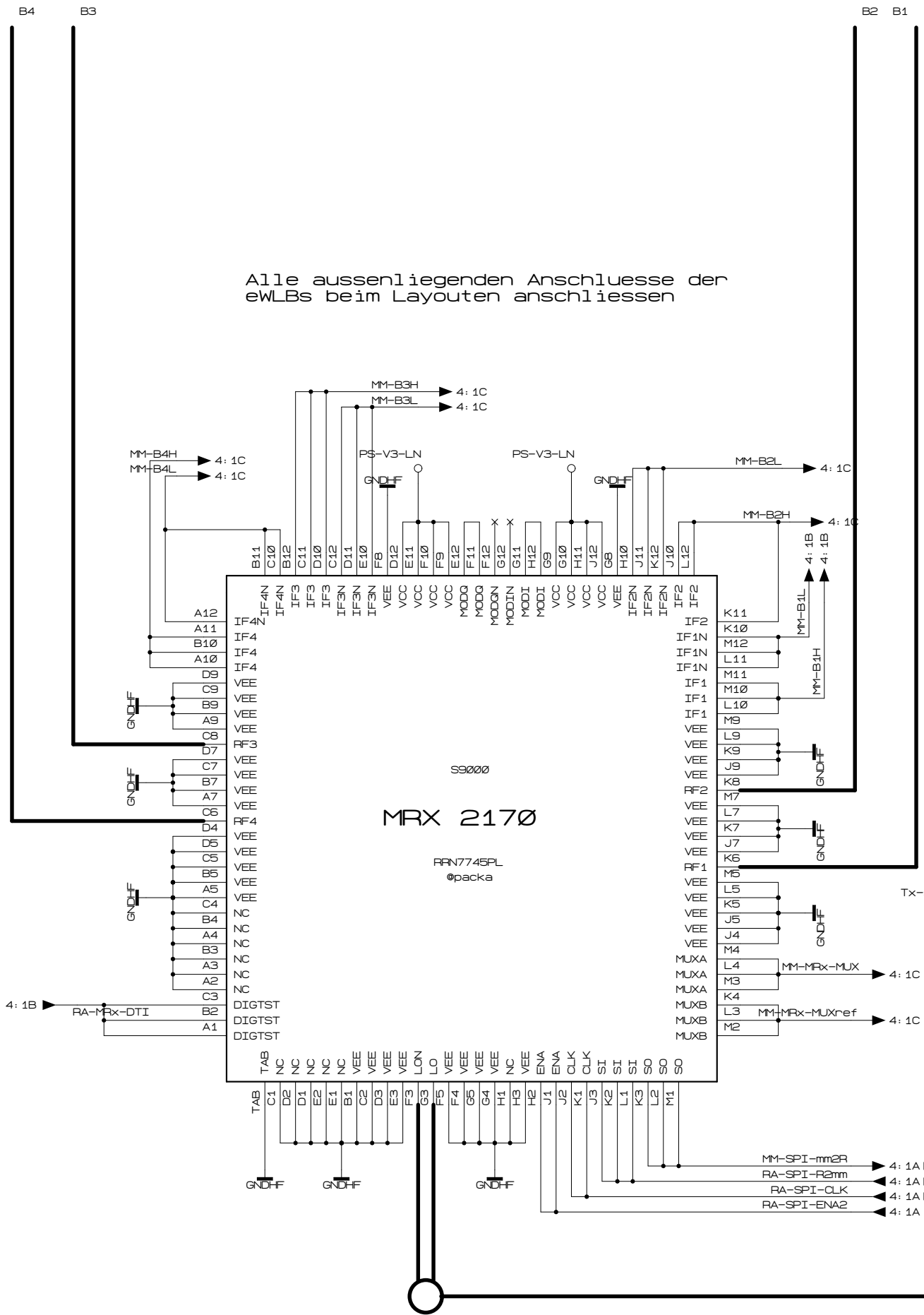

NAME	DWN	CHK	APP	TITLE	
Schmid	Msoega	-	-	MRR1corner CP2 C1 Radar-LP MMICs	
DATE	15.12.2015	---	---	DWN: @dono	
Plot Date	16/03/22	Plot Variant Name		Board No. @bare	
Plot Time	09:20:13	Variation Comment		NO. 0265064137_01	
Q-19:	ROBERT BOSCH	Partlist No.:		5 of 5	
DIN	STUTTGART	EPCN No.:			
A 2		Top_Level_No.:			
		Top_Level_Titel:			

© Robert Bosch GmbH. All rights reserved. Also regarding any disposal, exploitation, reproduction, editing, distributing, as well as in the event of applications for industrial property rights.