

From
XC-DA/ESR1

Our Reference
Robert Bloch

Tel
+49 711 811 18813

Leonberg
19 October 2021

Report

Issue 2
 Topic **CR5TPCC User Manual**
 Description Specific for Radio International Type Approval purposes.

Contents

- 1 Description of CR5TPCC parts 2
- 2 Operation principle of the CR5TPCC 3
- 3 User information 3
 - 3.1 General description 3
 - 3.2 Areas of application 3
 - 3.2.1 Predictive emergency braking system 4
 - 3.2.2 Adaptive cruise control (ACC)..... 4
 - 3.2.3 Heading distance indicator 5
 - 3.2.4 Sensor data fusion..... 5
 - 3.3 National Statements 5
 - 3.3.1 European Union..... 5
 - 3.3.2 United Kingdom..... 6
 - 3.3.3 Canada..... 6
 - 3.3.4 United States..... 6
- 4 Vehicle integration 7
 - 4.1 Radar cone..... 7
 - 4.2 Fascia design guidelines 9
 - 4.3 Installation hints..... 10
- 5 Calibration 14
- 6 Technical Data..... 15

From
XC-DA/ESR1

Our Reference
Robert Bloch

Tel
+49 711 811 18813

Leonberg
19 October 2021

Report
Issue 2
Topic CR5TPCC User Manual

1 Description of CR5TPCC parts

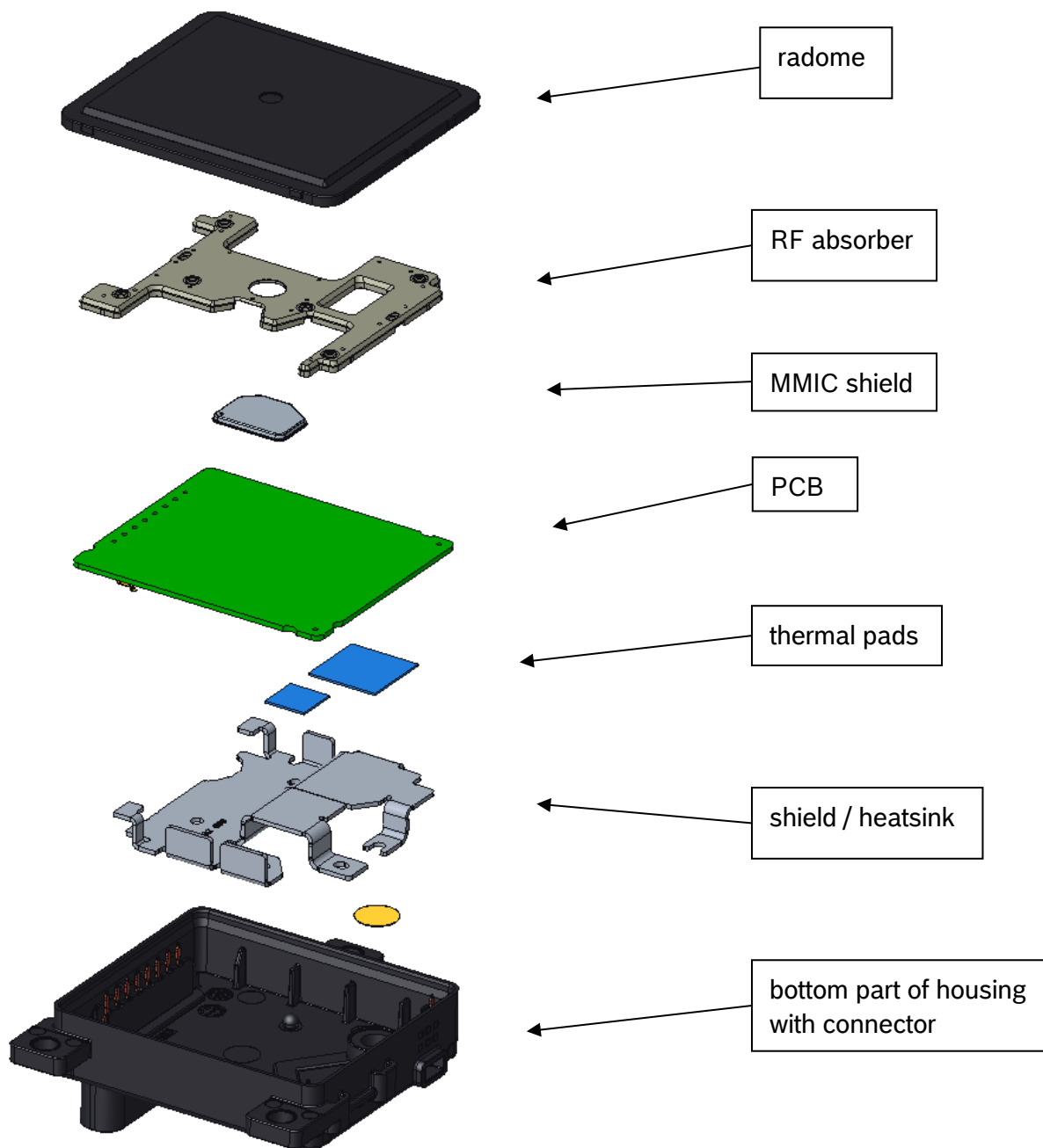

From
XC-DA/ESR1

Our Reference
Robert Bloch

Tel
+49 711 811 18813

Leonberg
19 October 2021

Report
Issue 2
Topic CR5TPCC User Manual

2 Operation principle of the CR5TPCC

The radar sensor's purpose is detection of objects and measurement of their speed and position relative to the movement of the vehicle in which it is mounted.

CR5TPCC senses targets by emitting many short frequency modulated waves using the transmit antennas while receiving waves reflected by targets using the receive antennas. Distance and relative speed are determined by measurement of signal's travel time and Doppler shift. Direction of the target is determined by using phase difference of the received signal between different Rx antennas.

Using the Bosch chirp sequence radar modulation, the CR5TPCC allows unambiguous determination of relative speed in a single measurement cycle. Therefore, no complex object models are needed for ambiguity resolution.

The values calculated from detected radar reflections are basis for building a comprehensive model of the sensed environment.

3 User information

3.1 General description

The CR5TPCC radar sensor and control unit (SCU) contains a FMCW radar transceiver operating in the globally harmonized frequency range of 76.0 - 77.0 GHz. It senses targets by emitting many short frequency modulated waves using the transmit antennas while receiving waves reflected by targets using the receive antennas. Distance and relative speed are determined via beat frequency (due to travelling time of the waves) and phase differences between ramps (due to change of distance in short time). By using the antenna diagram, the angles of departure and arrival of the radar waves can be determined.

Fitted in front of the vehicle, the CR5TPCC monitors continuously vehicle surroundings, supporting driver and vehicle systems with emergency braking, cruise control and distance indicator.

3.2 Areas of application

The CR5TPCC is the base for range of safety and driver assistance functions. In particular, the CR5TPCC can be used for the following functions:

From
XC-DA/ESR1

Our Reference
Robert Bloch

Tel
+49 711 811 18813

Leonberg
19 October 2021

Report
Issue 2
Topic CR5TPCC User Manual

3.2.1 Predictive emergency braking system

With the CR5TPCC, vehicle manufacturers can meet the requirements for the automatic emergency braking systems “AEB City” and “AEB Urban” as outlined in the Euro NCAP assessment scheme.

With its predictive emergency braking system, Bosch is helping to prevent rear-end collisions and reduce the severity of accidents. The system becomes active as soon as the vehicle started, and supports the driver at all speeds – both day and night.

If the predictive emergency braking system determines that the distance to the preceding vehicle is becoming critical short, it prepares the braking system for potential emergency braking. If the driver does not react to the hazardous situation, the system warns the driver via an audible and/or visual signal, followed by a short but noticeable brake jerk.

The system then initiates partial braking to reduce the speed and give the driver valuable time to react. As soon as the driver presses the brake pedal, the system provides braking support. To do this, the system continuously calculates the degree of vehicle deceleration required to avoid the collision. If the system detects that the driver has failed to apply sufficient brake force, it increases the braking pressure to the required level so that the driver can attempt to bring the vehicle to a standstill before a collision occurs.

If the driver fails to react to the immediate risk of collision, and the predictive emergency braking system detects that a rear-end-collision is unavoidable, it can – working in conjunction with a video camera – automatically initiate full braking. As a result, the vehicle is traveling at significantly reduced speed when the collision occurs, reducing the severity of the crash for the passengers of both vehicles.

If the predictive emergency braking system detects that the distance to a moving or stationary vehicle in front is becoming critically short, it prepares the braking system for a potential emergency braking procedure. If the driver fails to react to the critical situation, the system can automatically initiate full braking in an attempt to prevent the collision. If the rear-end collision is unavoidable, this action can at least minimize the severity of the collision, reducing the risk of injury to the passengers of both vehicles.

3.2.2 Adaptive cruise control (ACC)

The CR5TPCC makes it possible to detect vehicles merging at an early stage – making it the ideal extension of front radar (like FR5CP) for ACC systems.

The ACC system automatically maintains a set distance from the vehicle ahead by automatically reducing the power to the engine, braking or accelerating. The ACC stop & go variant can also automatically apply the brakes until the vehicle comes to a standstill and will resume automatically when instructed by the driver.

From
XC-DA/ESR1

Our Reference
Robert Bloch

Tel
+49 711 811 18813

Leonberg
19 October 2021

Report
Issue 2
Topic CR5TPCC User Manual

3.2.3 Heading distance indicator

This function measures the distance from the objects around vehicle and, depending on the speed at which the vehicle is travelling, warns the driver when the safe distance from the vehicle in front is not being maintained. The function does not intervene independently, but instead informs the driver of the distance from other vehicle via a visual and/or audible signal.

3.2.4 Sensor data fusion

The CR5TPCC can support sensor data fusion without the need for additional hardware. Sensor data fusion combines the benefits of different sensors and measuring principles in the most effective way possible, providing data that individual sensors working in isolation are unable to generate. Fusion of multiple sensors increases the measurement range, reliability and accuracy.

Video sensors, such as the multi-purpose camera or the stereo video camera from Bosch, are the ideal supplement to radar technology. Using software algorithms, the fusion of sensor data generates a detailed “image”, which forms the basis for an interpretation of the vehicle’s surroundings.

Sensor fusion enables the implementation of additional assistance and safety functions, such as pedestrian protection (“AEB Pedestrian”). The function for predictive pedestrian protection meets the safety requirements as specified by Euro NCAP. It continually monitors, in combination with a video camera, the area around vehicle in order to detect impending collisions with pedestrians who are in the path of the vehicle or moving toward it in a way that is likely to present a risk. If the function detects that pedestrians are at risk, it can actively trigger application of the brakes in order to considerably reduce the risk and the consequences of the collision, or to prevent the accident altogether.

Sensor data fusion can also be used to significantly improve the performance of the comfort functions. Thanks to the high degree of lateral measuring accuracy of a video camera, the ACC function is able, for example, to detect vehicles merging at an earlier stage, and therefore respond in a more dynamic manner. The system also ensures that vehicles in front are assigned to the correct lanes, which further enhances ACC functionality, especially when cornering.

3.3 National Statements

3.3.1 European Union

This device should be installed and operated with minimum distance of 20 cm between the front of device and human body.

From
XC-DA/ESR1

Our Reference
Robert Bloch

Tel
+49 711 811 18813

Leonberg
19 October 2021

Report
Issue 2
Topic CR5TPCC User Manual

3.3.2 United Kingdom

This device should be installed and operated with minimum distance of 20 cm between the front of device and human body.

3.3.3 Canada

This device complies with Industry Canada license-exempt RSS standard(s). Operation is subject to the following two conditions:

- (1) this device must not cause interference, and
- (2) this device must accept any interference, including interference that may cause undesired operation of the device.

Le présent appareil est conforme aux CNR d'Industrie Canada applicables aux appareils radio exempts de licence. L'exploitation est autorisée aux deux conditions suivantes:

- (1) l'appareil ne doit pas produire de brouillage, et
- (2) l'utilisateur de l'appareil doit accepter tout brouillage radioélectrique subi, même si le brouillage est susceptible d'en compromettre le fonctionnement.

3.3.4 United States

This device complies with Part 15 of the FCC Rules.

Operation is subject to the following two conditions:

- (1) this device may not cause harmful interference, and
- (2) this device must accept any interference received, including interference that may cause undesired operation.

Changes or modifications made to this equipment not expressly approved by Robert Bosch GmbH may void the FCC authorization to operate this equipment.

This equipment has been tested and found to comply with the limits for a Class A digital device, pursuant to Part 15 of the FCC Rules. These limits are designed to provide reasonable protection against harmful interference when the equipment is operated in a commercial environment. This equipment generates, uses, and can radiate radio frequency energy and, if not installed and used in accordance with the instruction manual, may cause harmful interference to radio communications. Operation of this equipment in a

From
XC-DA/ESR1

Our Reference
Robert Bloch

Tel
+49 711 811 18813

Leonberg
19 October 2021

Report
Issue 2
Topic CR5TPCC User Manual

residential area is likely to cause harmful interference in which case the user will be required to correct the interference at his own expense.

Radiofrequency radiation exposure Information:

This equipment complies with FCC radiation exposure limits set forth for an uncontrolled environment. This equipment should be installed and operated with minimum distance of 20 cm between the radiator and your body.

This transmitter must not be co-located or operating in conjunction with any other antenna or transmitter.

4 Vehicle integration

This chapter describes the requirements for all parts mounted in front or around the sensor, like painted bumper, unpainted cover and emblem/radome, regarding RF integration at 77 GHz with CR5Plus radar sensors. If these requirements are not met, the sensor performance can be degraded.

Values are marked with t.b.c. or t.b.d. showing that they have to be confirmed or defined during the development process.

As product development is an on-going process, we reserve the right to make amendments in line with technical progress.

The radar sensor performance should be influenced as low as possible by the installation behind a fascia. Therefore the two-way radar loss by the fascia should be as low as possible and the reflection attenuation must fulfill the requirements listed below.

Vertical misalignment will cause additional attenuation reducing the maximum range.

Horizontal misalignment will cause reduced detection at higher azimuth angles.

Ghost target detection caused by interference signals of multiple reflection at fascia and metallic parts of the vehicle must be avoided. A simulation can be offered to evaluate the risk and the need of using absorber material to suppress this unwanted signal. Because the threshold of detection is very low, a high attenuation is required. Plastic material can only achieve high enough attenuation, if carbon black is added.

4.1 Radar cone

The radar cone describes the zone where the fascia has to be optimized. Any parts of the vehicle inside the radar cone may influence the radar performance. Cables, brackets, bars etc. should not touch the radar cone. The fascia in this zone may not have bends and edges as well as changes in thickness or material or painting.

From
XC-DA/ESR1

Our Reference
Robert Bloch

Tel
+49 711 811 18813

Leonberg
19 October 2021

Report
Issue 2
Topic CR5TPCC User Manual

Based on the footprint on the top side of the radar PCB the cone is characterized by a vertical and a horizontal opening angle. The footprint is centered regarding to the sensor housing. A CAD model of the radar cone is available.

The footprint for radar cone has the following dimensions: (W x H) 55 mm x 55 mm

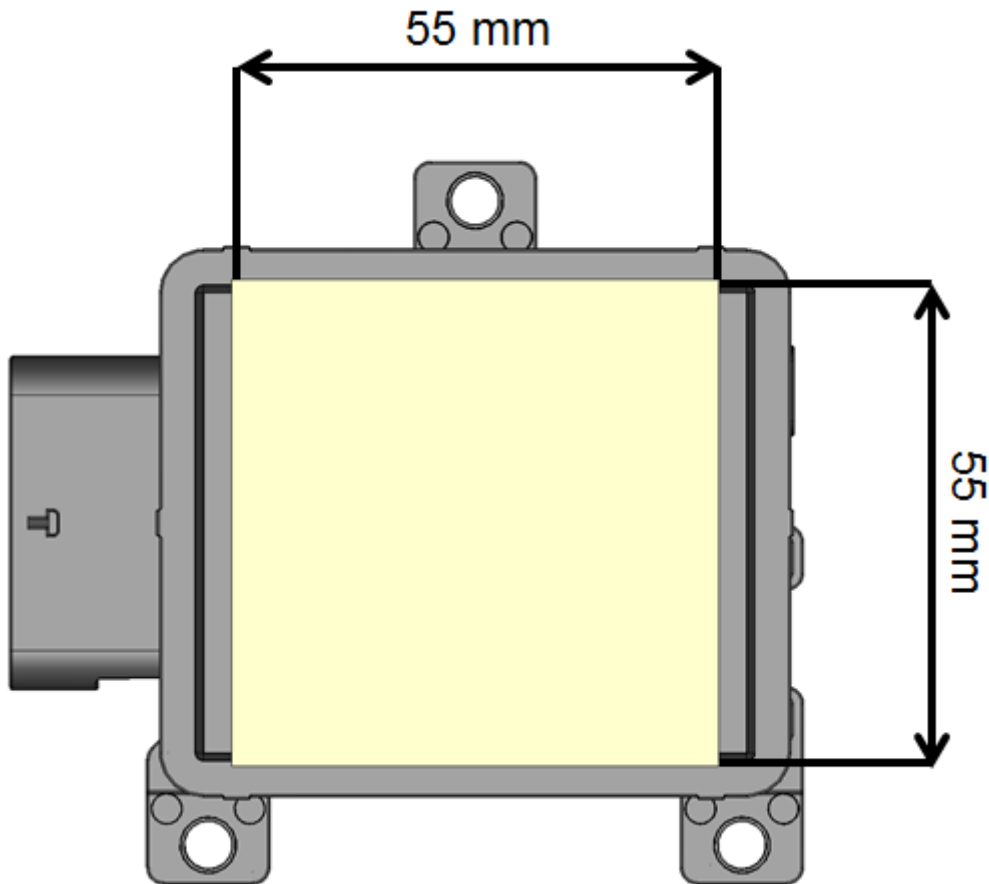

Figure 2: Footprint of the radar cone. For better visibility, the footprint is shown on top of the sensor housing.

Radar cone definition for covered installation (CR5TPCC):

The horizontal opening angle depends on the angle range that is evaluated by the sensor in azimuth and elevation, whereby the opening angle of the radar cone has to be larger than the angle range that is evaluated. For covered integration the radar cone is 10° larger than the used angle range that is evaluated by the sensor.

From
XC-DA/ESR1

Our Reference
Robert Bloch

Tel
+49 711 811 18813

Leonberg
19 October 2021

Report
Issue 2
Topic CR5TPCC User Manual

Radar cone:

- $\pm 80^\circ$ ⁽¹⁾ (tbc) in horizontal direction (not including misalignment)
- $\pm 20^\circ$ (tbc) in vertical direction (not including misalignment)

(1) Valid for angle measurement range of $\pm 70^\circ$

4.2 *Fascia design guidelines*

Material

Material with low dielectric constant (ϵ_r) and low dielectric loss factor $\tan\delta$ at 77 GHz should be used. Recommended are materials based on polypropylene (PP) and polymethyl methacrylate (PMMA), while materials like polycarbonate (PC) and acrylonitrile butadiene styrene (ABS) are still ok. The material shall be homogenous, compounds including glass fiber, carbon fiber or metal particles are not recommended.

The fascia shall be designed for radar transparency. The thickness shall be a multiple of the half wavelength (in the material) to minimize the influence of the fascia. The quality criteria of radar transparency is the reflection coefficient of the radome/fascia. Tolerances of the overall thickness and the dielectric constant of the used material influence the amount of reflection at the radome/fascia. Additional influence occurs due to curvature of the fascia. Therefore the radius has to be as large as possible. With sharp edges the negative influence will increase significantly. Not allowed are ribs, structures and steps changing the thickness of the radome/fascia.

Painting

The layer structure of the painting, typically made of three painting layers consisting of primer, base coating and clear coating, will increase the effective permittivity value $\epsilon_{r,eff}$ and dielectric loss factor $\tan\delta$ of the painted plate used as fascia.

Fascia Classification (CR5TPCC)

The two-way radar loss caused by the fascia should be as low as possible. High losses decrease the sensor performance regarding range and angle estimation. Therefore it is recommended to achieve a two-way radar loss below 4 dB(t.b.c.). This corresponds to a loss of 20% of sensor range.

From
XC-DA/ESR1

Our Reference
Robert Bloch

Tel
+49 711 811 18813

Leonberg
19 October 2021

Report
Issue 2
Topic CR5TPCC User Manual

Classification of reflection caused by the fascia

1.	Reflection coefficient <-10 dB
	is achieved when fascia has optimized thickness within a tolerance of ± 0.2 mm and permittivity within a tolerance ± 0.02 . Dielectric loss factor $\tan \delta$ shall be < 0.03 .
2.	Reflection coefficient <-6 dB
	is achieved when fascia has optimized thickness within a tolerance of ± 0.2 mm and permittivity within a tolerance of ± 0.2 . Dielectric loss factor $\tan \delta$ shall be < 0.05 . This is the case for painted bumper especially when various colors are used.
3.	Reflection coefficient >-6 dB
	is achieved when fascia has no optimized thickness or a painting with high metallic content is used. The attenuation may exceed the maximum allowed limit.

The examples described in the classification of reflection are derived from evaluation of flat plates with constant thickness and homogeneous material. Deviations from this situation may cause a change in classification and the vertical tilt angle of fascia has to be increased.

Surface Properties of the fascia

The surfaces of the fascia shall not exceed an average roughness height of 20 μm (corresponding to ISO 1302 class N10; VDI 3400 class 45).

4.3 Installation hints

To enable the full performance of the radar sensor, it is recommended to use the following installation hints and guidelines for the RF integration of the sensor.

From
XC-DA/ESR1

Our Reference
Robert Bloch

Tel
+49 711 811 18813

Leonberg
19 October 2021

Report
Issue 2
Topic CR5TPCC User Manual

Maximum angle between radar cone and fascia

The angle α between the radar beam inside the radar cone and the fascia may not be larger than 80° anywhere inside the radar cone

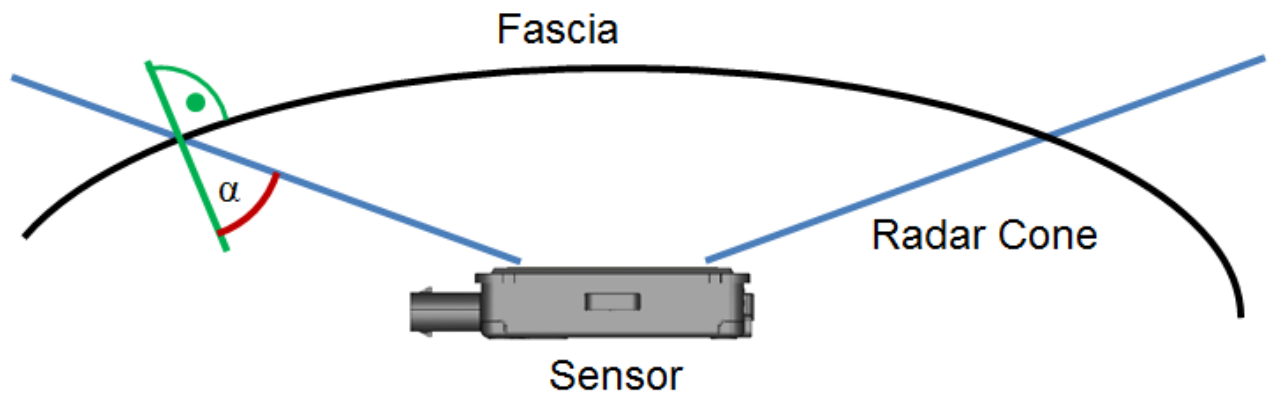

Figure 3: Maximum angle between fascia and radar cone

Minimum distance between sensor and fascia

The minimum distance between the sensor radome and the fascia or any other part of the vehicle may not be smaller than 5 mm.

This is valid for fascia parts fulfilling the following requirements.

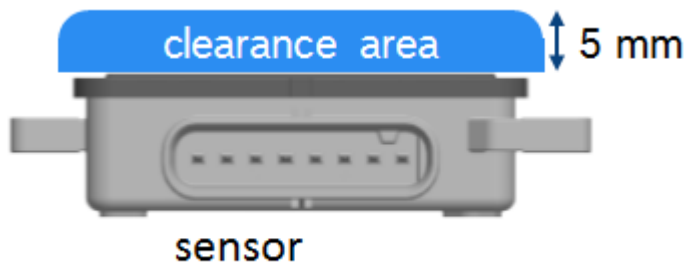

Figure 4: Minimum distance above sensor radome

From
XC-DA/ESR1

Our Reference
Robert Bloch

Tel
+49 711 811 18813

Leonberg
19 October 2021

Report
Issue 2
Topic CR5TPCC User Manual

Vertical tilt of fascia (CR5TPCC)

The vertical tilt angle between the sensor normal and the surface normal of the fascia shall be in the range according to the following table.

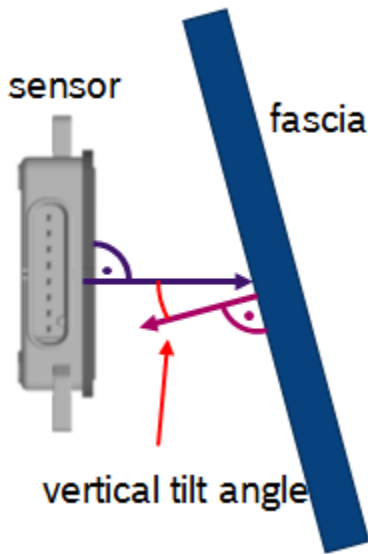

Figure 5: vertical tilt angle of fascia to sensor normal

Vertical tilt angle:

Vertical tilt	reflection coefficient	max. tolerance thickness	permittivity ϵ_r	tolerance ϵ_r	$\tan\delta$	application
	<-10 dB	± 0.1 mm	single value	± 0.02	<0.01	unpainted/ painted (with optimized thickness for each color) fascia
>15°	>-10 dB	± 0.2 mm	single value	± 0.02	<0.03	unpainted/ painted (with optimized thickness for each color) fascia
		± 0.1 mm	range from 2.5 to 3.2	± 0.2	<0.03	painted fascia

From
XC-DA/ESR1

Our Reference
Robert Bloch

Tel
+49 711 811 18813

Leonberg
19 October 2021

Report
Issue 2
Topic CR5TPCC User Manual

Curvature of fascia for CR5TPCC

Curvature of the fascia may influence the radar performance, especially with low vertical tilt angles. The minimum radius of the curvature shall be according to the following rules:

- R > 350 mm, no significant influence expected
- R < 350 mm, significant influence possible, has to be evaluated
- R < 200 mm, significant influence expected, not recommended

Absorber around the sensor

It is highly recommended to use a cone made of absorber material around the radar cone of the sensor to prevent ghost targets. The design of the absorber cone must fulfill the following design guidelines (reflection from outside the radar cone, multipath reflection).

Reflection from outside the radar cone

Reflections from structures located outside the radar cone have to be avoided. Furthermore interference signals picked up by the sensor antennas should be avoided by keeping a minimum distance (d) of 5 mm to 10 mm for parts in front of the sensor. Even with compliance to the radar cone, reflections at parts outside the radar cone may disturb the received signal. Reflections at parts causing an interference signal to the receiving antenna and reflections at parts getting to the receiving antenna after a second reflection at the fascia (multipath reflection). Closed surfaces of brackets and masks made of metal or high reflecting material need a tilt angle being arranged that the reflection is not received by the receiving antennas of the sensor.

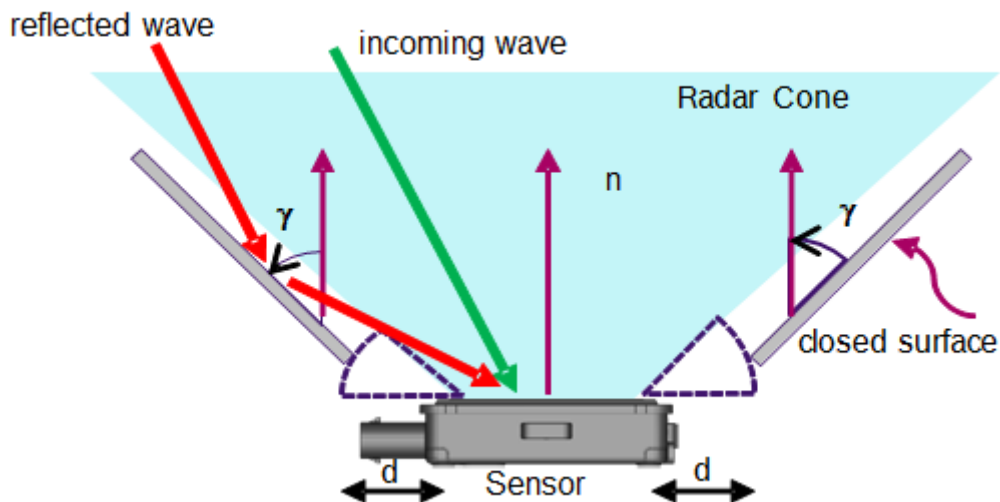

Figure 6: Reflection at bracket or mask

From
XC-DA/ESR1

Our Reference
Robert Bloch

Tel
+49 711 811 18813

Leonberg
19 October 2021

Report
Issue 2
Topic CR5TPCC User Manual

For closed surfaces (masks) in azimuth, the angle γ between mask surface and the normal vector n of the sensor shall be greater than the azimuth opening angle of the radar cone. For closed surfaces (masks) in elevation, the angle γ between mask surface and the normal vector n of the sensor shall be greater than the azimuth opening angle of the radar cone.

Multipath reflection

Reflections of incoming signals at bracket or shielding absorber are coming back to the sensor if reflection at the bumper occurs. The figure below shows the situation which should be avoided. The worst case happens if the combination of the vertical tilt angles of shielding and bumper is $\gamma_1 = \gamma_2 / 2$. For a low interference signal the condition shall be:

$$\gamma_1 > \gamma_2 / 2 + 10^\circ$$

or

$$\gamma_1 < \gamma_2 / 2 - 10^\circ$$

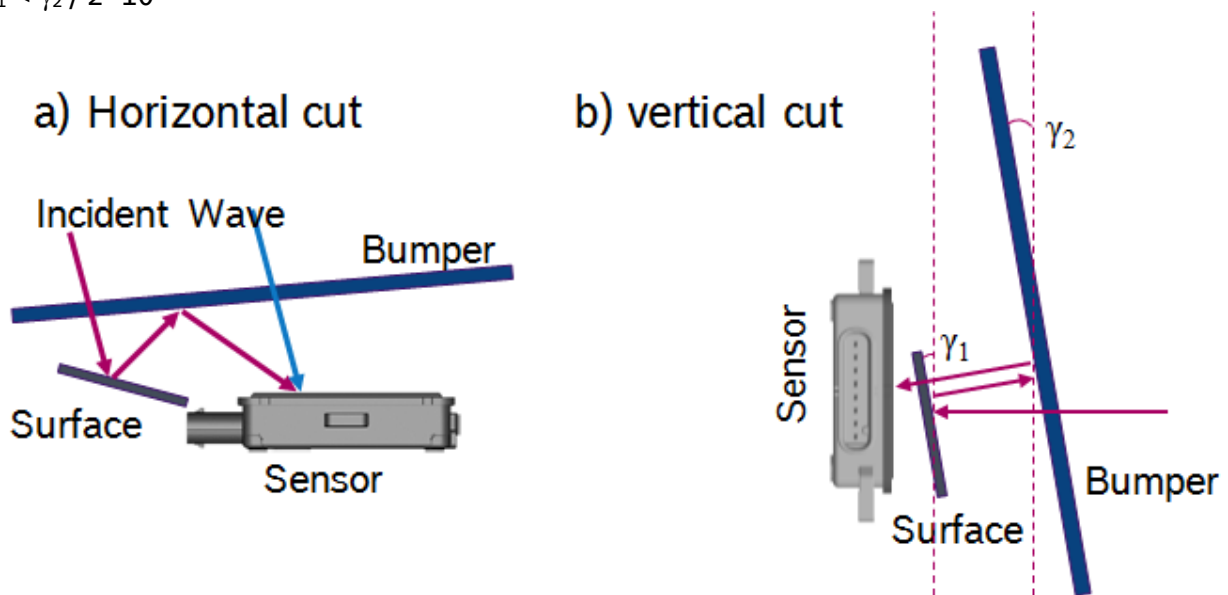

Figure 7: Requirements for parts outside radar cone to avoid multipath reflection

The same requirements are valid for a horizontal tilt of the fascia.

5 Calibration

No manual alignment procedure is necessary, as the sensor performs it's own internal SW calibration.



From
XC-DA/ESR1

Our Reference
Robert Bloch

Tel
+49 711 811 18813

Leonberg
19 October 2021

Report
Issue 2
Topic CR5TPCC User Manual

References for Chapter 5 & 6 of this document:

TCD_CR5TPCC_Preliminary.doc

Version –preliminary- with date: -

6 Technical Data

Product model name:	CR5TPCC
Frequency Band:	76-77 GHz
Maximum Transmit Power: Nominal mean EIRP	20,9 dBm
Maximum Transmit Power: Measured mean EIRP	20,49 dBm
Maximum Transmit Power: Measured peak EIRP	29,64 dBm

XC-DA/ESR1