

BOSCH 	Installation and Manual Documentation	Document date:
CC-DA/ESR1	CR5CPCCF	18 Feb 2020

Product identification Product name	CR5CPCCF
Type designation	Corner Radar 5 Car Plus CAN CAN Flexray
Series parts number	
Number of the offer drawing	
Name of customer	
Number, issue/version, date, and title of the customer specification	TCD Extract
Version and date of the TCD	Version 1.0 (initial) – 18.02.2020
Issued by	Robert Bloch
Internal Bosch Baseline ID	



BOSCH 	Installation and Manual Documentation	Document date:
CC-DA/ESR1	CR5CPCCF	18 Feb 2020

Table of contents

1.	General product description.....	3
1.1.	Main functions and properties of the product	3
1.1.1.	Principle	3
1.1.2.	Block diagram.....	4
1.1.3.	Preliminary Assembly concept.....	5
1.2.	Labeling of the product.....	6
1.2.1.	Radio Frequency Homologation	6
1.2.1.1.	Phrases and Markings.....	6
1.3.	Dimensions and weights.....	13
1.4.	Power consumption / power output.....	13
1.5.	General remarks for service, repair and maintenance	13
1.6.	Information on disposal and recycling.....	13
2.	System description	14
2.1.	Vehicle integration interfaces.....	14
2.1.1.1.	Radar Cone	14
2.1.1.2.	Fascia design guidelines	16
2.1.1.3.	Installation Hints	18
3.	Technical data with measured variables and measuring conditions	22
3.1.	Mechanical characteristics.....	22
3.2.	Electrical characteristics	23
3.2.1.	Electrical Vehicle Connector Pinning	24
3.2.1.1.	Pin Properties.....	24
3.2.1.2.	Pin Assignment	24
3.2.2.	Vehicle Power Supply.....	25
3.2.2.1.	Constraints and Definitions.....	25
3.2.2.2.	Power Supply System 12V	25
3.2.3.	Mounting recognition	26

BOSCH 	Installation and Manual Documentation	Document date:
CC-DA/ESR1	CR5CPCCF	18 Feb 2020

1. General product description

The present technical customer documentation describes CR5CPCCF, for which the Robert Bosch GmbH has the assigned responsibility. In addition, it contains noncommittal descriptions of components and functionalities, which are not in the responsibility of Robert Bosch GmbH, but nonetheless determine or influence the behavior and performance of the particular vehicle type series.

1.1. Main functions and properties of the product

1.1.1. Principle

The CR5CP radar sensor and control unit (SCU) contains a FMCW radar transceiver operating in the globally harmonized frequency range of 76.0 - 77.0 GHz. It senses targets by emitting many short frequency modulated waves using the transmit antennas while receiving waves reflected by targets using the receive antennas. Distance and relative speed are determined via beat frequency (due to travelling time of the waves) and phase differences between ramps (due to change of distance in short time). By using the antenna diagram the angles of departure and arrival of the radar waves can be determined.

Using the Bosch chirp sequence radar modulation, the CR5CP allows unambiguous determination of relative speed in a single measurement cycle. Therefore, no complex object models are needed for ambiguity resolution.

The radar reflections (strength, distance and relative speed, angular direction, and derived values) are basis for building a comprehensive model of the sensed environment.

BOSCH 	Installation and Manual Documentation	Document date:
CC-DA/ESR1	CR5CPCCF	18 Feb 2020

1.1.2. Block diagram

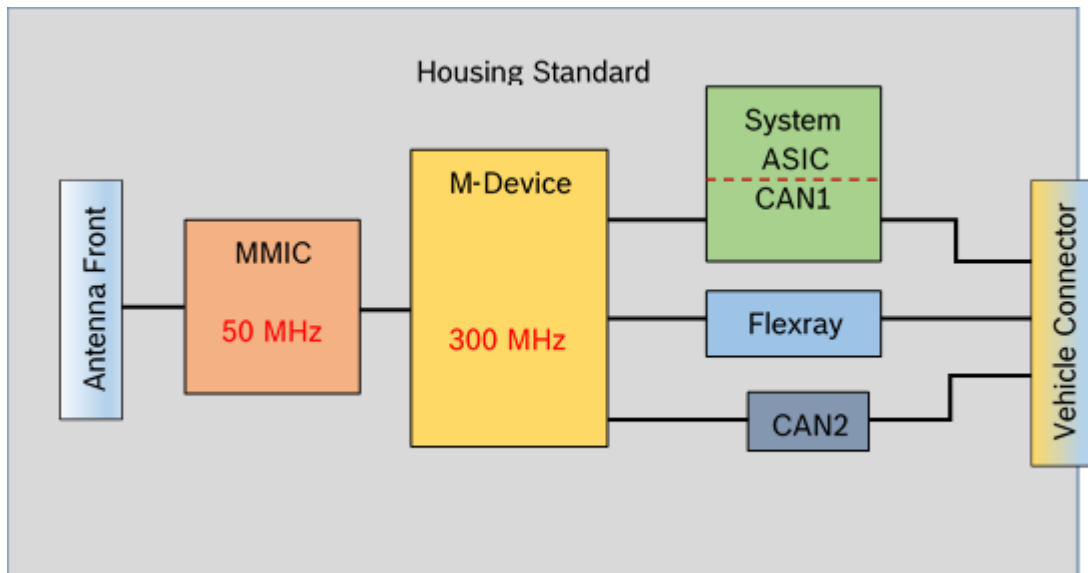



Figure: Block diagram

The CR5CPCCF sensor is build on a single printed circuit board with integrated components:

- Microcontroller (M-Device) with multi-core architecture and dedicated radar signal processing unit (SPU), Flash and RAM memory, peripheral units, CAN transceiver, as well as safety features
- Radar Frontend MMIC in SiGe technology for frequency generation (VCO, PLL and sequencer), power amplifiers (PA) and receiver including mixer, analog frontend processing, ADC and digital frontend processing with digital baseband interface to the microcontroller as well as clock generation and safety features
- Planar antenna array with three transmit antennas and four receive antennas
- A System-ASIC with power supply for internal voltages (except microcontroller core power supply), a safety controller (SCON) with watchdog functionality and CAN-transceiver
- FlexRay PHY (transceiver)

BOSCH 	Installation and Manual Documentation	Document date:
CC-DA/ESR1	CR5CPCCF	18 Feb 2020

1.1.3. Preliminary Assembly concept

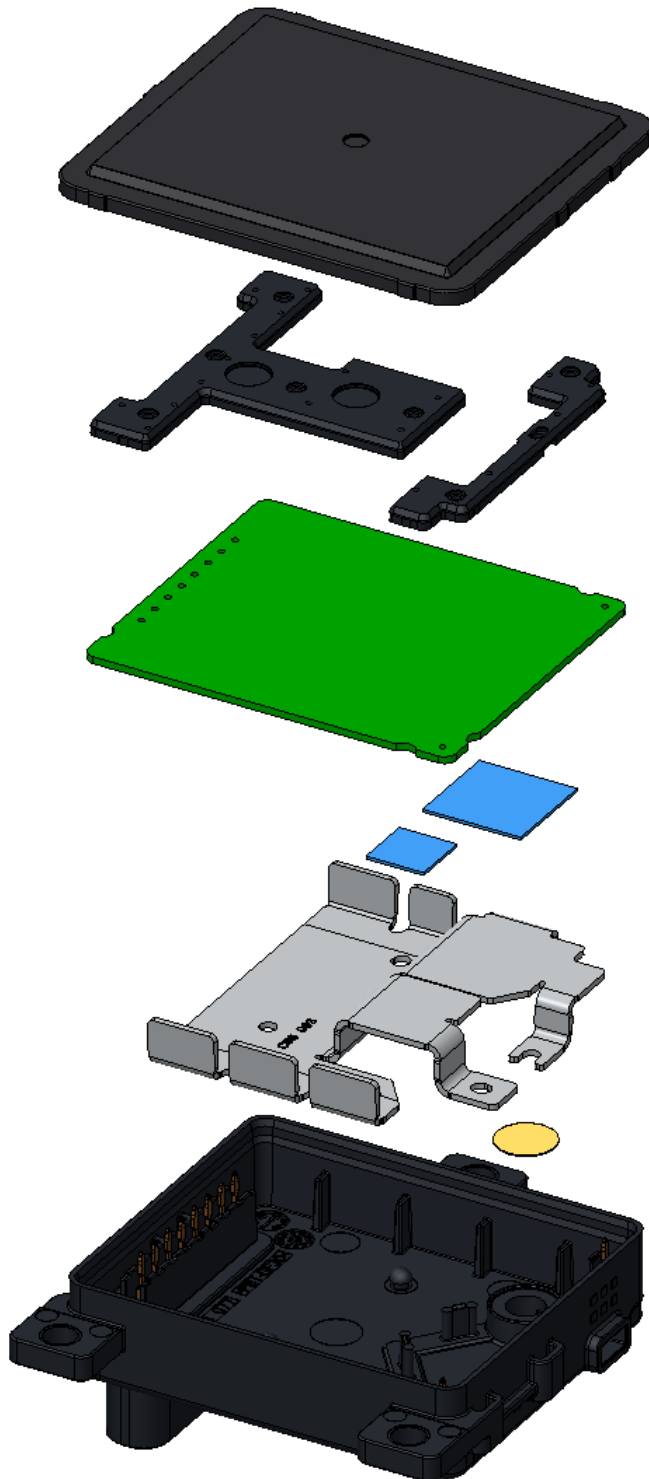



Figure: Assembly concept

With only 3 main components (radome, PCB, lower housing), the assembly of the CR5CP SCU is quite simple and is focusing to robust and cost effective mass production.

BOSCH 	Installation and Manual Documentation	Document date:
CC-DA/ESR1	CR5CPCCF	18 Feb 2020

1.2. Labeling of the product

The radar devices provide information about:

- part-number
- series-number
- hardware and software version
- barcode information
- production date
- radar emission release information
- customer information

1.2.1. Radio Frequency Homologation

1.2.1.1. Phrases and Markings

The following phrases and markings are part of the radio frequency homologation and have to be reproduced in the vehicle user manual.

- 1.2.1.1.1. *Australia***
- 1.2.1.1.2. *Qatar***
- 1.2.1.1.3. *South Africa***
- 1.2.1.1.4. *Singapore***
- 1.2.1.1.5. *Ukraine***
- 1.2.1.1.6. *Serbia***
- 1.2.1.1.7. *Moldova***
- 1.2.1.1.8. *Mexico***
- 1.2.1.1.9. *Phillipines***
- 1.2.1.1.10. *Indonesia***
- 1.2.1.1.11. *Brunei Daressalam***
- 1.2.1.1.12. *Jordania***
- 1.2.1.1.13. *United Arabic Emirates***
- 1.2.1.1.14. *Morocco***

BOSCH 	Installation and Manual Documentation	Document date:
CC-DA/ESR1	CR5CPCCF	18 Feb 2020

1.2.1.1.15. Malaysia

1.2.1.1.16. South Korea

1.2.1.1.17. Brazil

1.2.1.1.18. Taiwan

1.2.1.1.19. China

1.2.1.1.20. Hong Kong

1.2.1.1.21. Japan

1.2.1.1.22. Europe

In order to obtain CE marking, compliance to the essential requirements of the Radio Equipment Directive (2014/53/EU) have to be demonstrated.

Therefore a Declaration of Conformity (DoC), listing the applied standards to fulfill the essential requirements of the Radio Equipment Directive (2014/53/EU), will be made available in the Robert Bosch GmbH - DoC Database - for download under the following link: <http://eu-doc.bosch.com>

The European homologation mark will be applied on the sensor.

European homologation mark according to Radio Equipment Directive (RE-D) 2014/53/EC:



Legal text for RF equipment (simplified DoC) translated in all official EU languages::

(EN) EC DECLARATION OF CONFORMITY

Hereby, Robert Bosch GmbH declares that the radio equipment type **CR5CPCCF** is in compliance with Directive 2014/53/EU. The full text of the EU declaration of conformity is available at the following internet address: <http://eu-doc.bosch.com>

(DE) EU-KONFORMITÄTSERKLÄRUNG

Hiermit erklärt Robert Bosch GmbH, dass der Funkanlagentyp **CR5CPCCF** der Richtlinie 2014/53/EU entspricht. Der vollständige Text der EU-Konformitätserklärung ist unter der folgenden Internetadresse verfügbar: <http://eu-doc.bosch.com>

BOSCH 	Installation and Manual Documentation	Document date:
CC-DA/ESR1	CR5CPCCF	18 Feb 2020

(BG) ЕС ДЕКЛАРАЦИЯ ЗА СЪОТВЕТСТВИЕ

С настоящото Robert Bosch GmbH декларира, че този тип радиосъоръжение **CR5CPCCF** е в съответствие с Директива 2014/53/ЕС. Цялостният текст на ЕС декларацията за съответствие може да се намери на следния интернет адрес: <http://eu-doc.bosch.com>

(HR) EU IZJAVA O SUKLADNOSTI

Robert Bosch GmbH ovime izjavljuje da je radijska oprema tipa **CR5CPCCF** u skladu s Direktivom 2014/53/EU. Cjeloviti tekst EU izjave o sukladnosti dostupan je na sljedećoj internetskoj adresi: <http://eu-doc.bosch.com>

(EL) ΔΗΛΩΣΗ ΣΥΜΜΟΡΦΩΣΗΣ ΕΕ

Με την παρούσα ο/η Robert Bosch GmbH, δηλώνει ότι ο ραδιοεξοπλισμός **CR5CPCCF** πληροί την οδηγία 2014/53/ΕΕ. Το πλήρες κείμενο της δήλωσης συμμόρφωσης ΕΕ διατίθεται στην ακόλουθη ιστοσελίδα στο διαδίκτυο: <http://eu-doc.bosch.com>

(CS) EU PROHLÁŠENÍ O SHODĚ

Tímto Robert Bosch GmbH prohlašuje, že typ rádiového zařízení **CR5CPCCF** je v souladu se směrnicí 2014/53/EU. Úplné znění EU prohlášení o shodě je k dispozici na této internetové adrese: <http://eu-doc.bosch.com>

(DA) EU-OVERENSSTEMMELSESERKLÆRING

Hermed erklærer Robert Bosch GmbH, at radioudstyrstypen **CR5CPCCF** er i overensstemmelse med direktiv 2014/53/EU. EU-overensstemmelseserklæringens fulde tekst kan findes på følgende internetadresse: <http://eu-doc.bosch.com>

(ET) ELI VASTAVUSDEKLARATSIOON

Käesolevaga deklareerib Robert Bosch GmbH, et käesolev raadioseadme tüüp **CR5CPCCF** vastab direktiivi 2014/53/EL nõuetele. ELi vastavusdeklaratsiooni täielik tekst on kättesaadav järgmisel internetiaadressil: <http://eu-doc.bosch.com>

(FI) EU-VAATIMUSTENMUKAISUUSVAKUUTUS

Robert Bosch GmbH vakuuttaa, että radiolaitetyyppi **CR5CPCCF** on direktiivin 2014/53/EU mukainen. EU-vaatimustenmukaisuusvakuutuksen täysimittainen teksti on saatavilla seuraavassa internetosoitteessa: <http://eu-doc.bosch.com>

(FR) DECLARATION UE DE CONFORMITE

Le soussigné, Robert Bosch GmbH, déclare que l'équipement radioélectrique du type **CR5CPCCF** est conforme à la directive 2014/53/UE. Le texte complet de la déclaration UE de conformité est disponible à l'adresse internet suivante: <http://eu-doc.bosch.com>

BOSCH 	Installation and Manual Documentation	Document date:
CC-DA/ESR1	CR5CPCCF	18 Feb 2020

(HU) EU-MEGFELELŐSÉGI NYILATKOZAT

Robert Bosch GmbH igazolja, hogy a **CR5CPCCF** típusú rádióberendezés megfelel a 2014/53/EU irányelvnek. Az EU-megfelelőségi nyilatkozat teljes szövege elérhető a következő internetes címen: <http://eu-doc.bosch.com>

(IT) DICHIARAZIONE DI CONFORMITÀ UE

Il fabbricante, Robert Bosch GmbH, dichiara che il tipo di apparecchiatura radio **CR5CPCCF** è conforme alla direttiva 2014/53/UE. Il testo completo della dichiarazione di conformità UE è disponibile al seguente indirizzo Internet <http://eu-doc.bosch.com>

(LV) ES ATBILSTĪBAS DEKLARĀCIJA

Ar šo Robert Bosch GmbH deklarē, ka radioiekārta **CR5CPCCF** atbilst Direktīvai 2014/53/ES. Pilns ES atbilstības deklarācijas teksts ir pieejams šādā interneta vietnē: <http://eu-doc.bosch.com>

(LT) ES ATITIKTIES DEKLARACIJA

Aš, Robert Bosch GmbH, patvirtinu, kad radijo įrenginių tipas **CR5CPCCF** atitinka Direktyvą 2014/53/ES. Visas ES atitikties deklaracijos tekstas prieinamas šiuo interneto adresu: <http://eu-doc.bosch.com>

(MT) DIKJARAZZJONI TA' KONFORMITÀ TAL-UE

B'dan, Robert Bosch GmbH, niddikjara li dan it-tip ta' tagħmir tar-radju **CR5CPCCF** huwa konformi mad-Direttiva 2014/53/UE. It-test kollu tad-dikjarazzjoni ta' konformità tal-UE huwa disponibbli f'dan l-indirizz tal-Internet li ġej: <http://eu-doc.bosch.com>

(NL) EU-CONFORMITEITSVERKLARING

Hierbij verklaar ik, Robert Bosch GmbH, dat het type radioapparatuur **CR5CPCCF** conform is met Richtlijn 2014/53/EU. De volledige tekst van de EU-conformiteitsverklaring kan worden geraadpleegd op het volgende internetadres: <http://eu-doc.bosch.com>

(PL) DEKLARACJA ZGODNOŚCI UE

Robert Bosch GmbH niniejszym oświadcza, że typ urządzenia radiowego **CR5CPCCF** jest zgodny z dyrektywą 2014/53/UE. Pełny tekst deklaracji zgodności UE jest dostępny pod następującym adresem internetowym: <http://eu-doc.bosch.com>

(PT) DECLARAÇÃO UE DE CONFORMIDADE

O(a) abaixo assinado(a) Robert Bosch GmbH declara que o presente tipo de equipamento de rádio **CR5CPCCF** está em conformidade com a Diretiva 2014/53/UE. O texto integral da declaração de conformidade está disponível no seguinte endereço de Internet: <http://eu-doc.bosch.com>

BOSCH 	Installation and Manual Documentation	Document date:
CC-DA/ESR1	CR5CPCCF	18 Feb 2020

(RO) DECLARAȚIA UE DE CONFORMITATE

Prin prezenta, Robert Bosch GmbH declară că tipul de echipamente radio **CR5CPCCF** este în conformitate cu Directiva 2014/53/UE. Textul integral al declarației UE de conformitate este disponibil la următoarea adresă internet: <http://eu-doc.bosch.com>

(SK) EÚ VYHLÁSENIE O ZHODE

Robert Bosch GmbH týmto vyhlasuje, že rádiové zariadenie typu **CR5CPCCF** je v súlade so smernicou 2014/53/EÚ. Úplné EÚ vyhlásenie o zhode je k dispozícii na tejto internetovej adrese: <http://eu-doc.bosch.com>

(SL) IZJAVA EU O SKLADNOSTI

Robert Bosch GmbH potrjuje, da je tip radijske opreme **CR5CPCCF** skladen z Direktivo 2014/53/EU. Celotno besedilo izjave EU o skladnosti je na voljo na naslednjem spletnem naslovu: <http://eu-doc.bosch.com>

(ES) DECLARACIÓN UE DE CONFORMIDAD

Por la presente, Robert Bosch GmbH declara que el tipo de equipo radioeléctrico **CR5CPCCF** es conforme con la Directiva 2014/53/UE. El texto completo de la declaración UE de conformidad está disponible en la dirección Internet siguiente: <http://eu-doc.bosch.com>

(SV) EU-FÖRSÄKRAN OM ÖVERENSSTÄMMELSE

Härmed försäkras Robert Bosch GmbH att denna typ av radioutrustning **CR5CPCCF** överensstämmer med direktiv 2014/53/EU. Den fullständiga texten till EU-försäkran om överensstämmelse finns på följande webbadress: <http://eu-doc.bosch.com>

BOSCH 	Installation and Manual Documentation	Document date:
CC-DA/ESR1	CR5CPCCF	18 Feb 2020

1.2.1.1.23. USA

Once FCC approval is granted for CR5CPCCF, the following FCC ID has to be included in the vehicle user manual and labelled on the product.

FCC ID: NF3-CR5CPCCF

The following warning text for RF equipment has to be included in the vehicle user manual:

User Manual statement according to §15.19

This device complies with Part 15 of the FCC Rules. Operation is subject to the following two conditions:

- 1. this device may not cause harmful interference, and*
- 2. this device must accept any interference received, including interference that*
- 3. may cause undesired operation.*

User Manual statement according to §15.21:

Changes or modifications made to this equipment not expressly approved by Robert BOSCH GmbH may void the FCC authorization to operate this equipment.

User Manual statement according to §15.105:

This equipment has been tested and found to comply with the limits for a Class A digital device, pursuant to Part 15 of the FCC Rules. These limits are designed to provide reasonable protection against harmful interference when the equipment is operated in a commercial environment. This equipment generates, uses, and can radiate radio frequency energy and, if not installed and used in accordance with the instruction manual, may cause harmful interference to radio communications. Operation of this equipment in a residential area is likely to cause harmful interference in which case the user will be required to correct the interference at his own expense.

RF Exposure Information according 2.1091 / 2.1093 / KDB 447498 / OET bulletin 65:

Radio frequency radiation exposure Information:

This equipment complies with FCC radiation exposure limits set forth for an uncontrolled environment. This equipment should be installed and operated with minimum distance of 20 cm between the radiator and your body. This transmitter must not be co-located or operating in conjunction with any other antenna or transmitter.

BOSCH 	Installation and Manual Documentation	Document date:
CC-DA/ESR1	CR5CPCCF	18 Feb 2020

1.2.1.1.24. Canada

Once Canada approval is granted for CR5CPCCF the following ISED certification number, PMN and HVIN has to be included in the vehicle user manual and labelled on the product on the product.

IC: 3887A-CR5CPCCF

HVIN: CR5CPCCF

PMN: Corner Radar 5 Car Plus CAN CAN Flexray

The following warning text for RF equipment has to be included in the vehicle user manual:

RF equipment according to RSS_GEN in English and French language

This device complies with Industry Canada license-exempt RSS standard(s). Operation is subject to the following two conditions: (1) this device must not cause interference, and (2) this device must accept any interference, including interference that may cause undesired operation of the device.

Le présent appareil est conforme aux CNR d'Industrie Canada applicables aux appareils radio exempts de licence. L'exploitation est autorisée aux deux conditions suivantes: (1) l'appareil ne doit pas produire de brouillage, et (2) l'utilisateur de l'appareil doit accepter tout brouillage radioélectrique subi, même si le brouillage est susceptible d'en compromettre le fonctionnement.

RF Exposure Information according to RSS-102 in English and French language:

This equipment complies with FCC and IC radiation exposure limits set forth for an uncontrolled environment. This equipment should be installed and operated with minimum distance of 20 cm between the radiator and your body. This transmitter must not be co-located or operating in conjunction with any other antenna or transmitter.

Cet équipement est conforme aux limites d'exposition aux rayonnements IC établies pour un environnement non contrôlé. Cet équipement doit être installé et utilisé avec un minimum de 20 cm de distance entre la source de rayonnement et votre corps. Ce transmetteur ne doit pas être placé au même endroit ou utilisé simultanément avec un autre transmetteur ou antenne.

1.2.1.1.25. Argentina

BOSCH 	Installation and Manual Documentation	Document date:
CC-DA/ESR1	CR5CPCCF	18 Feb 2020

1.3. Dimensions and weights

Outside dimension:

Box volume, total Length (depth in X-direction) = 18.7 mm

Detailed dimensions see offer drawing.

Outside dimension:

Box volume, total Width = 62.6mm

Detailed dimensions see offer drawing.

Outside dimension:

Box volume, total Height = 72mm

Detailed dimensions see offer drawing.

Maximum weight of complete SCU (w/o heating) w/o mounting device and poka yoke element >80gr.

1.4. Power consumption / power output

This section describes the power consumption of the SCU for different operating states.

Symbol	Parameter	Note or Test Condition	min	typ	max	Unit
P_RF_on	operating power consumption	- RF on, approx. 30% duty cycle - COM Interfaces ON - Processing Unit: M - VBATT=14V +/- 5%	-	4		W
Symbol	Parameter	Note or Test Condition	min	typ	max	Unit
P_RF_off	operating power consumption	- RF off - COM Interfaces ON - Processing Unit: M - VBATT=14V +/- 5%	-	2,5		W

1.5. General remarks for service, repair and maintenance

Repair and maintenance of the product is not allowed

Sensor can't be opened without damaging.

In case of service the Sensor needs to be replaced.

1.6. Information on disposal and recycling

All Materials are released regarding the following regulations:

- ELV (Altautorichtlinie) and GADSL (BBM)
- RoHS
- REACH

BOSCH 	Installation and Manual Documentation	Document date:
CC-DA/ESR1	CR5CPCCF	18 Feb 2020

2. System description

2.1. Vehicle integration interfaces

This chapter describes the requirements for all parts mounted in front or around the sensor, like painted bumper, unpainted cover and emblem/radome, regarding RF integration at 77 GHz with CR5Plus radar sensors. If these requirements are not met, the sensor performance can be degraded.

Values are marked with t.b.c. or t.b.d. showing that they have to be confirmed or defined during the development process.

As product development is an on-going process, we reserve the right to make amendments in line with technical progress.

The radar sensor performance should be influenced as low as possible by the installation behind a fascia. Therefore the two-way radar loss by the fascia should be as low as possible and the reflection attenuation must fulfill the requirements listed below.

Vertical misalignment will cause additional attenuation reducing the maximum range.

Horizontal misalignment will cause reduced detection at higher azimuth angles.

Ghost target detection caused by interference signals of multiple reflection at fascia and metallic parts of the vehicle must be avoided. A simulation can be offered to evaluate the risk and the need of using absorber material to suppress this unwanted signal. Because the threshold of detection is very low, a high attenuation is required. Plastic material can only achieve high enough attenuation, if carbon black is added.

2.1.1.1. Radar Cone

Radar Cone for PLUS Family

The radar cone describes the zone where the fascia has to be optimized. Any parts of the vehicle inside the radar cone may influence the radar performance. Cables, brackets, bars etc. should not touch the radar cone. The fascia in this zone may not have bends and edges as well as changes in thickness or material or painting.

Based on the footprint on the top side of the radar PCB the cone is characterized by a vertical and a horizontal opening angle. The footprint is centered regarding to the sensor housing. A CAD model of the radar cone is available.

The footprint for radar cone has the following dimensions: (W x H) 55 mm x 55 mm

BOSCH 	Installation and Manual Documentation	Document date:
CC-DA/ESR1	CR5CPCCF	18 Feb 2020

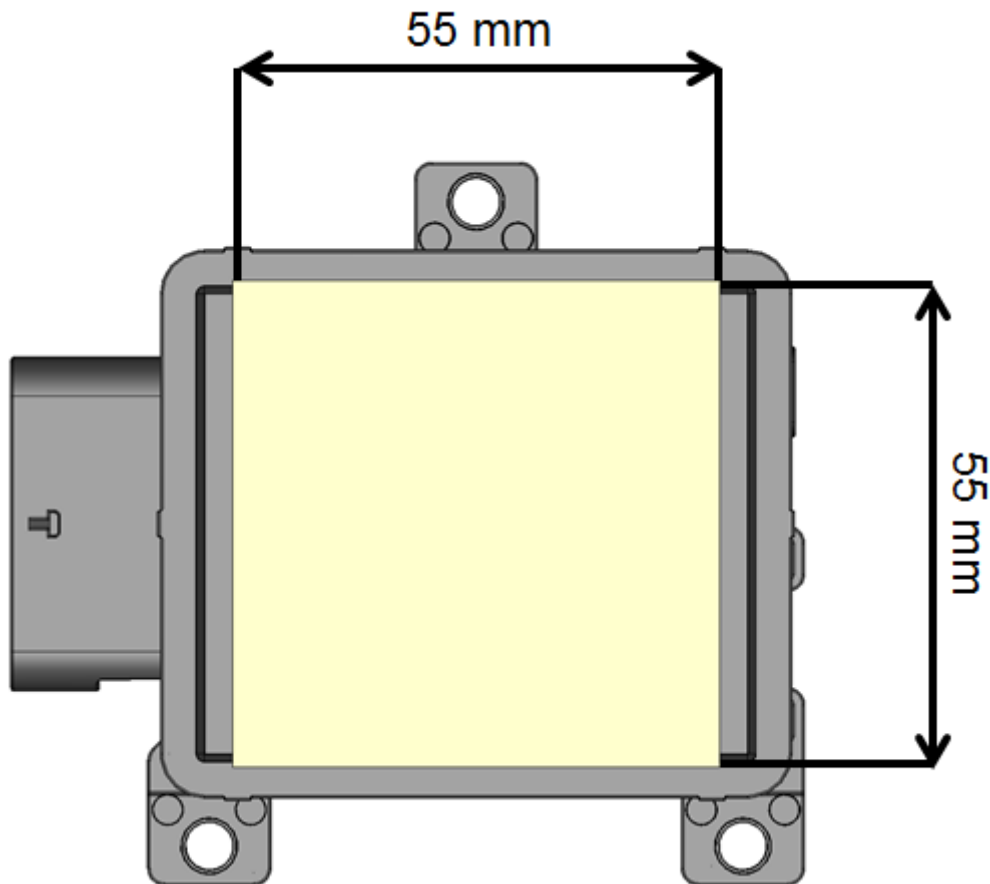

Figure: Footprint of the radar cone. For better visibility the footprint is shown on top of the sensor housing.

Radar cone definition for covered installation (CR5CP):

The horizontal opening angle depends on the angle range that is evaluated by the sensor in azimuth and elevation, whereby the opening angle of the radar cone has to be larger than the angle range that is evaluated. For covered integration the radar cone is 10° larger than the used angle range that is evaluated by the sensor.

Radar cone:

- $\pm 80^\circ$ ⁽¹⁾ (tbc) in horizontal direction (not including misalignment)
- $\pm 20^\circ$ (tbc) in vertical direction (not including misalignment)

⁽¹⁾ Valid for angle measurement range of $\pm 70^\circ$

BOSCH 	Installation and Manual Documentation	Document date:
CC-DA/ESR1	CR5CPCCF	18 Feb 2020

2.1.1.2. Fascia design guidelines

Material

Material with low dielectric constant (ϵ_r) and low dielectric loss factor $\tan\delta$ at 77 GHz should be used. Recommended are materials based on polypropylene (PP) and polymethyl methacrylate (PMMA), while materials like polycarbonate (PC) and acrylonitrile butadiene styrene (ABS) are still ok. The material shall be homogenous, compounds including glass fiber, carbon fiber or metal particles are not recommended.

The fascia shall be designed for radar transparency. The thickness shall be a multiple of the half wavelength (in the material) to minimize the influence of the fascia. The quality criteria of radar transparency is the reflection coefficient of the radome/fascia. Tolerances of the overall thickness and the dielectric constant of the used material influence the amount of reflection at the radome/fascia. Additional influence occurs due to curvature of the fascia. Therefore the radius has to be as large as possible. With sharp edges the negative influence will increase significantly. Not allowed are ribs, structures and steps changing the thickness of the radome/fascia.

Painting

The layer structure of the painting, typically made of three painting layers consisting of primer, base coating and clear coating, will increase the effective permittivity value $\epsilon_{r,eff}$ and dielectric loss factor $\tan\delta$ of the painted plate used as fascia.

Fascia Classification (CR5CP)

The two-way radar loss caused by the fascia should be as low as possible. High losses decrease the sensor performance regarding range and angle estimation. Therefore it is recommended to achieve a two-way radar loss below 4 dB(t.b.c.). This corresponds to a loss of 20% of sensor range.

BOSCH 	Installation and Manual Documentation	Document date:
CC-DA/ESR1	CR5CPCCF	18 Feb 2020

Classification of reflection caused by the fascia

1.	Reflection coefficient <-10 dB is achieved when fascia has optimized thickness within a tolerance of ± 0.2 mm and permittivity within a tolerance ± 0.02 . Dielectric loss factor $\tan \delta$ shall be <0.03.
2.	Reflection coefficient <-6 dB is achieved when fascia has optimized thickness within a tolerance of ± 0.2 mm and permittivity within a tolerance of ± 0.2 . Dielectric loss factor $\tan \delta$ shall be <0.05. This is the case for painted bumper especially when various colors are used.
3.	Reflection coefficient >-6 dB is achieved when fascia has no optimized thickness or a painting with high metallic content is used. The attenuation may exceed the maximum allowed limit.

The examples described in the classification of reflection are derived from evaluation of flat plates with constant thickness and homogeneous material. Deviations from this situation may cause a change in classification and the vertical tilt angle of fascia has to be increased.

Surface Properties of the fascia

The surfaces of the fascia shall not exceed an average roughness height of 20 μm (corresponding to ISO 1302 class N10; VDI 3400 class 45).

BOSCH 	Installation and Manual Documentation	Document date:
CC-DA/ESR1	CR5CPCCF	18 Feb 2020

2.1.1.3. Installation Hints

To enable the full performance of the radar sensor, it is recommended to use the following installation hints and guidelines for the RF integration of the sensor.

Maximum angle between radar cone and fascia

The angle α between the radar beam inside the radar cone and the fascia may not be larger than 80° anywhere inside the radar cone

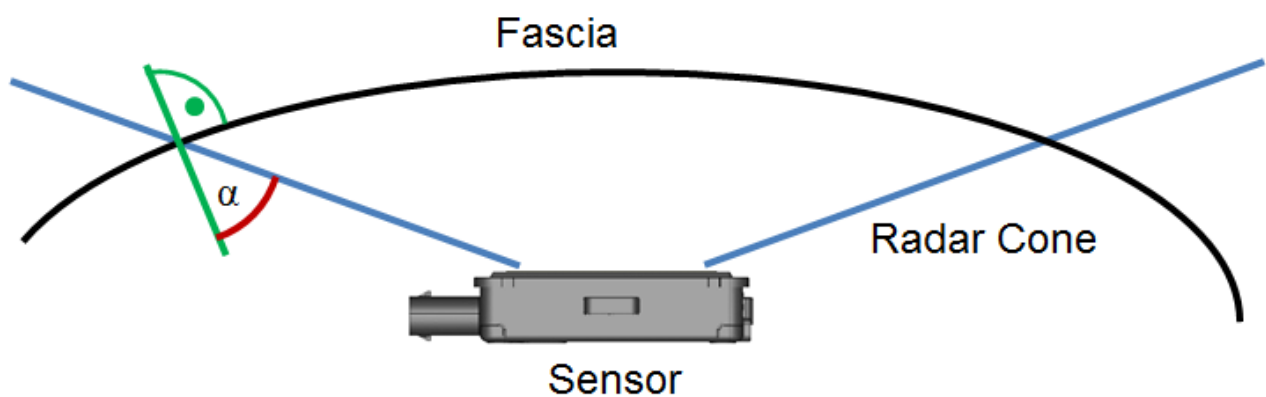

Figure: Maximum angle between fascia and radar cone

Minimum distance between sensor and fascia

The minimum distance between the sensor radome and the fascia or any other part of the vehicle may not be smaller than 5 mm.

This is valid for fascia parts fulfilling the following requirements.

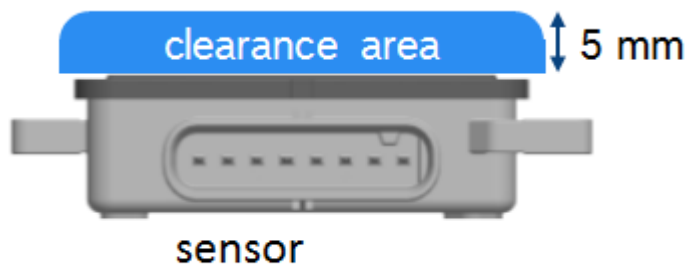



Figure: Minimum distance above sensor radome

Vertical tilt of fascia (CR5CP)

The vertical tilt angle between the sensor normal and the surface normal of the fascia shall be in the range according to the following table.

BOSCH 	Installation and Manual Documentation	Document date:
CC-DA/ESR1	CR5CPCCF	18 Feb 2020

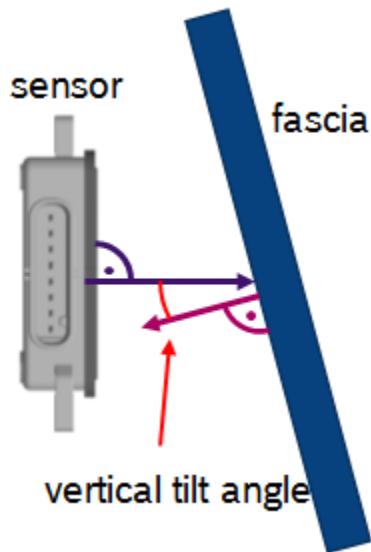



Figure: vertical tilt angle of fascia to sensor normal

Vertical tilt angle for high level functions (e.g. HWP, fCTA...):

Vertical tilt	reflection coefficient	max. tolerance thickness	tolerance ϵ_r	$\tan\delta$	application
	<-10 dB	± 0.1 mm	± 0.02	<0.01	unpainted, (black) painting, embleme
>8°	>-10 dB	± 0.2 mm	± 0.02	<0.03	unpainted, (black) painting, embleme
		± 0.1 mm	± 0.2	<0.03	painted bumper
>18°	>-6 dB	± 0.2 mm	± 0.2	<0.05	painted bumper

Table: minimum vertical tilt angle of fascia to sensor normal for High Level functions (e.g. HWP, fCTA...)

BOSCH 	Installation and Manual Documentation	Document date:
CC-DA/ESR1	CR5CPCCF	18 Feb 2020

Vertical tilt angle for low level functions (e.g. BSD, LCA A, DOW,...)

Vertical tilt	reflection coefficient	max. tolerance thickness	tolerance ϵ_r	$\tan\delta$	application
	>-10 dB < -6 dB	± 0.2 mm	± 0.02	<0.03	unpainted, (black) painting, embleme
		± 0.1 mm	± 0.2	<0.03	painted bumper
>8°	>-6 dB	± 0.2 mm	± 0.2	<0.05	painted bumper

Table: minimum vertical tilt angle of fascia to sensor normal for low level functions (e.g. BSD, LCA A, DOW,...)

Curvature of fascia for CR5CP

Curvature of the fascia may influence the radar performance, especially with low vertical tilt angles. The minimum radius of the curvature shall be according to the following rules:

- R > 350 mm, no significant influence expected
- R < 350 mm, significant influence possible, has to be evaluated
- R < 200 mm, significant influence expected, not recommended

Absorber around the sensor

It is highly recommended to use a cone made of absorber material around the radar cone of the sensor to prevent ghost targets. The design of the absorber cone must fulfill the following design guidelines (reflection from outside the radar cone, multipath reflection).

Reflection from outside the radar cone

Reflections from structures located outside the radar cone have to be avoided.

Furthermore interference signals picked up by the sensor antennas should be avoided by keeping a minimum distance (d) of 5 mm to 10 mm for parts in front of the sensor.

Even with compliance to the radar cone, reflections at parts outside the radar cone may disturb the received signal. Reflections at parts causing an interference signal to the receiving antenna and reflections at parts getting to the receiving antenna after a second reflection at the fascia (multipath reflection).

Closed surfaces of brackets and masks made of metal or high reflecting material need a tilt angle being arranged that the reflection is not received by the receiving antennas of the sensor.

BOSCH 	Installation and Manual Documentation	Document date:
CC-DA/ESR1	CR5CPCCF	18 Feb 2020

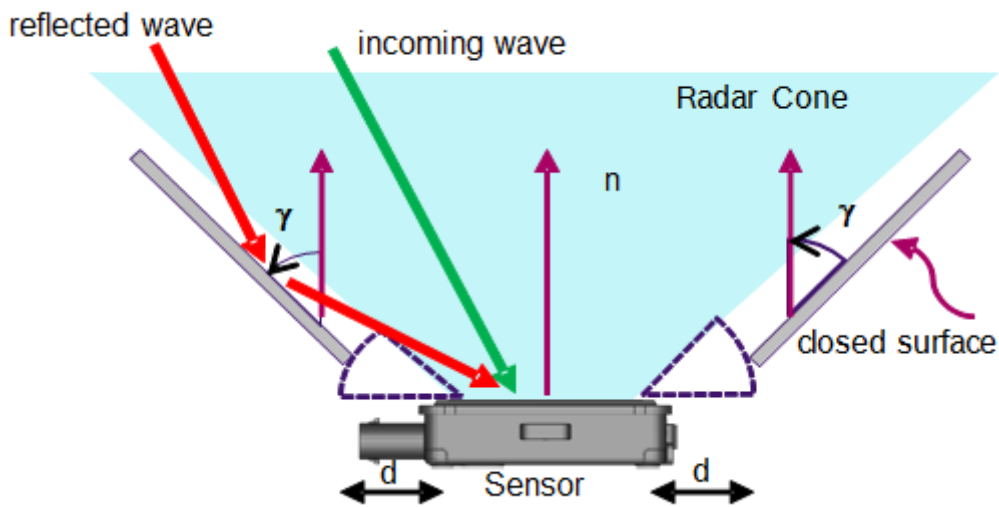

Figure: Reflection at bracket or mask

For closed surfaces (masks) in azimuth, the angle γ between mask surface and the normal vector \underline{n} of the sensor shall be above 75° for parts outside of the radar cone.

For closed surfaces (masks) in elevation, the angle γ between mask surface and the normal vector \underline{n} of the sensor shall be above 20° for parts outside of the radar cone.

Multipath reflection

Reflections of incoming signals at bracket or shielding absorber are coming back to the sensor if reflection at the bumper occurs. The figure below shows the situation which should be avoided. The worst case happens if the combination of the vertical tilt angles of shielding and bumper is $\gamma_1 = \gamma_2 / 2$. For a low interference signal the condition shall be:

$$\gamma_1 > \gamma_2 / 2 + 10^\circ$$

or

$$\gamma_1 < \gamma_2 / 2 - 10^\circ$$

BOSCH 	Installation and Manual Documentation	Document date:
CC-DA/ESR1	CR5CPCCF	18 Feb 2020

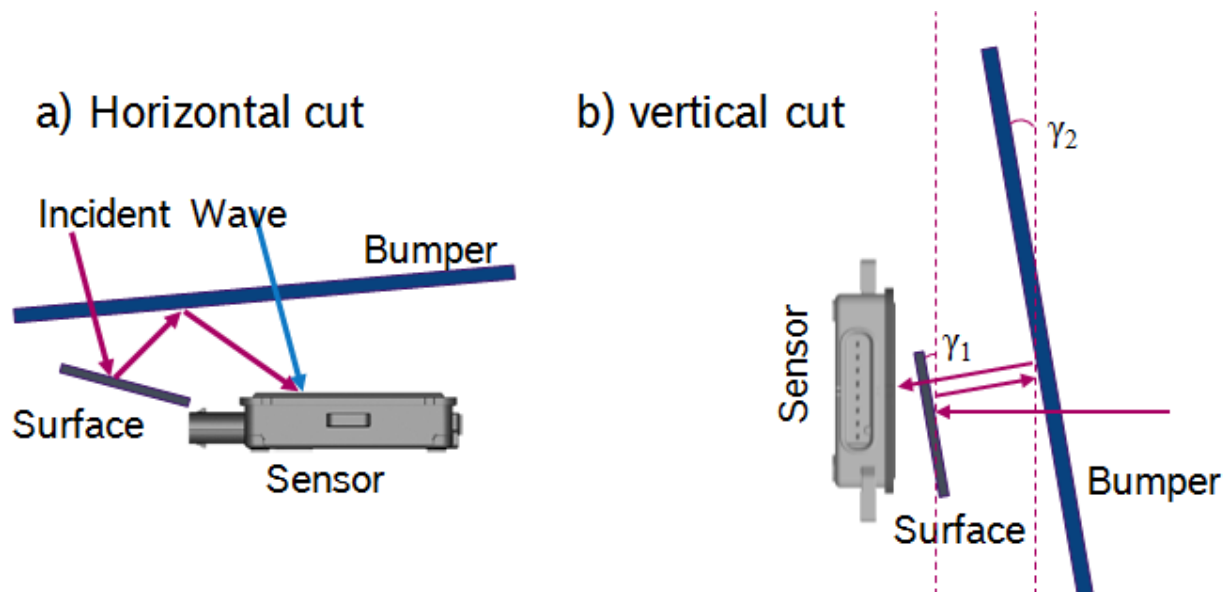

Figure: a) Requirements for parts outside radar cone to avoid multipath reflection

The same requirements are valid for a horizontal tilt of the fascia.

3. Technical data with measured variables and measuring conditions

3.1. Mechanical characteristics

Gravel bombardment:

According to ISO 20567-1 against back housing (covered installation)

Mechanical shock:

According to DIN EN 60068-2-27

500m/s² / 6ms duration

Mechanical vibration (broadband random vibration):

According to DIN EN 60068-2-64

Frequency spectrum 5 Hz - 2000 Hz according to the following profile

BOSCH 	Installation and Manual Documentation	Document date:
CC-DA/ESR1	CR5CPCCF	18 Feb 2020

Frequency [Hz]	PSD [(m/s ²) ² /Hz]
5	0,884
10	20
55	6,5
180	0,25
300	0,25
360	0,14
1000	0,14
2000	0,14

$a_{\text{eff}} = 30.8 \text{ m/s}^2$

Protection class:

According to International Protection Marking, ISO 20653
IP6Kx, IPx6K, IPx7, IPx9K

Temperature range with restricted operation (communication interface working):

Top_max=+85°C ... Tmax=+95°C.

Temperature range of operation:

Top_min= -40°C ... Top_max=+85°C.

Duration see Reliability

Corrosion resistance against salt spray and humidity

According to DIN EN 60068-2-11

Sensor may not be exposed to direct UV light for more than 48h

3.2. Electrical characteristics

The chapter electrical car integration describes the vehicle connector interface of the Radar SCU.

The detailed description of the following connection topics are adapted to the defined feature configuration:

- Connector Pinning
- Connector Power Supply Interface
- Connector Communication Interface
- Connector Multi-Purpose I/O Interface

BOSCH 	Installation and Manual Documentation	Document date:
CC-DA/ESR1	CR5CPCCF	18 Feb 2020

3.2.1. Electrical Vehicle Connector Pinning

This section describes the SCU vehicle connector pin properties and the connector pinning.

3.2.1.1. Pin Properties

Every connector pin is robust against short circuits to the supply voltage, to GND and to the neighbour pins. The resistance of the short circuit may be as low as 0,1 Ohm.

An unwanted supply of the ECU by any other pins than the dedicated power supply pins is impossible.

The ECU is robust against 5 kOhm shunt between adjacent pins of the vehicle connector caused by dirt. No disturbance of the functionality.

3.2.1.2. Pin Assignment

Vehicle connector pin number assignment

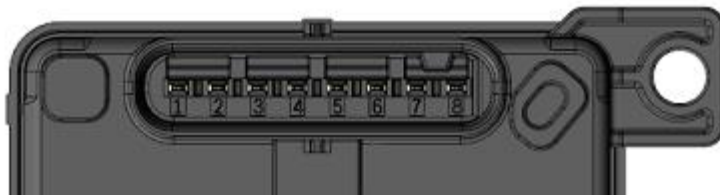

Pin No.	Designation	Description
1	MP-2	Multi Purpose pin 2 (COM-L)
2	MP-1	Multi Purpose pin 1 (COM-H)
3	COM2-L	Communication interface 2: Low signal
4	COM2-H	Communication interface 2: High signal
5	GND	Sensor ground: connected to terminal 31
6	COM1-L	Communication interface 1: Low signal
7	COM1-H	Communication interface 1: High signal
8	VBATT	Supply voltage for sensor (terminal 15/30)

Communication interface COM-L/H : CAN1

Pin 6: CAN_L

Pin 7: CAN_H

Communication interface COM-L/H : Daisy Chain CAN1

Pin 3: CAN_L

Pin 4: CAN_H

Pin 2 : Mounting Recognition 1

Pin 1: Mounting Recognition 2

BOSCH 	Installation and Manual Documentation	Document date:
CC-DA/ESR1	CR5CPCCF	18 Feb 2020

3.2.2. Vehicle Power Supply

3.2.2.1. Constraints and Definitions

The car battery supplies power to the Sensor (terminal 15/30)

All power supply parameters are measured at the ECU vehicle connector supply pins (VBATT to GND) unless different specified.

All power supply parameters are guaranteed and designed over ambient temperature Ta= Ta_min to Ta_max unless different specified. (-40°C to 85°C, see Chapter "Operating Environment")

All power supply parameters are guaranteed and designed over lifetime unless different specified.

All power supply values are continuous values.

Definition **COM Interfaces ON:**

COM interfaces are working according to the respective communication standard.

3.2.2.2. Power Supply System 12V

Symbol	Parameter	Note or Test Condition	min	typ	max	Unit
Umin	min. voltage without damaging the ECU	- reverse polarity - t <= 60s - Ri < 30mOhm	- 14,28	- 14,00		V
Symbol	Parameter	Note or Test Condition	min	typ	max	Unit
Umax_res_up	max. reset voltage Power Up		-	-	6,5	V
Symbol	Parameter	Note or Test Condition	min	typ	max	Unit
Umin_res_dn	min. reset voltage Power Down		-	-	4,5	V
Symbol	Parameter	Note or Test Condition	min	typ	max	Unit
Umin_com	min. communication voltage	- COM Interfaces ON - Object list preservation - min value Power Down	5,5	-	-	V

Symbol	Parameter	Note or Test Condition	min	typ	max	Unit
Umin_op	min. operating voltage	- COM Interfaces ON - RF Module ON	-	-	7,0	V
Symbol	Parameter	Note or Test Condition	min	typ	max	Unit
Umax_op	max. operating voltage	- COM Interfaces ON - RF Module ON	16	-	-	V
Symbol	Parameter	Note or Test Condition	min	typ	max	Unit
Umax_op	max. operating voltage	- COM Interfaces ON - RF Module ON	16	-	-	V

BOSCH 	Installation and Manual Documentation	Document date:
CC-DA/ESR1	CR5CPCCF	18 Feb 2020

Symbol	Parameter	Note or Test Condition	min	typ	max	Unit
Umax_com	max. communication voltage	- COM Interfaces ON - Object list preservation	see Umax_op	see Umax_op	see Umax_op	V
Symbol	Parameter	Note or Test Condition	min	typ	max	Unit
Umax	max. voltage without damaging the ECU		-	-	35	V

The inrush-current is below 30 A.

Condition: V_Batt=14.0V, 5m wire harness length, 0.5mm²

Typical inrush current plot for 5mtr wiring harness:

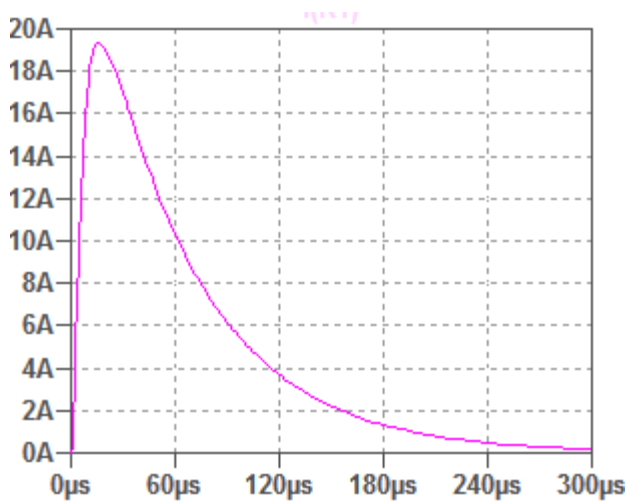

3.2.3. Mounting recognition

The mounting recognition is used to determine the location of the SCU inside the vehicle through configuration of the wire harness. This can be read out and used by the software to configure the sensor. Depending on the SCU configuration, one or more Mounting Recognition circuits are available.

External termination of the vehicle connector pin for separation of two mounting positions (e.g. right/left or front/rear):

- termination to GND
- no termination OPEN

A short circuit of the Vehicle Connector Pin against supply voltage can be recognised by the SW as error.

It is not possible to detect the errors short circuit to GND or open connection at the vehicle connector pins since they are used as valid input states (see above).

The circuit is not robust against a short circuit to V_BATT at the used vehicle connector pin(s) and application of reverse polarity at the same time.

BOSCH 	Installation and Manual Documentation	Document date:
CC-DA/ESR1	CR5CPCCF	18 Feb 2020

The functionality is not robust against a parallel resistance of 5kOhm to V_BATT. This will be recognized as short circuit to V_BATT error. No damage to the circuit will be caused.

Hint:

To increase error detection capability, it is possible to use two Mounting Recognition circuits (if available) for distinguishing two states. The external termination at the vehicle connector pins should be as follows:

Position1:

1st pin terminated to GND

2nd pin left OPEN

Position2:

1st pin left OPEN

2nd pin terminated to GND

Thus, following unwanted states at one or both Vehicle Connector Pins can be recognised by the SW as errors:

- Short circuit to supply voltage
- Short circuit to GND
- Interrupted connection (Open Load)

This product is an electronic device and sensitive to electrical discharge. Therefore, ESD standard protection according to IEC 61340-5-1 and IEC 61340-5-2 have to be obeyed at all times during handling and transportation. E.g. the pins of the product must not be touched at any time.