



TEST REPORT NO: RU1189/6473
COPY NO: 1
ISSUE NO: 1
FCC ID: NEOCE-470BDA

**REPORT ON THE CERTIFICATION TESTING OF
AERIAL FACILITIES LIMITED
60-056101 and 60-056102
WITH RESPECT TO
THE FCC RULES CFR 47, PART 90 SUBPART I**

TEST DATE: 12th – 16th July 2005

TESTED BY: _____ J CHARTERS
APPROVED BY: _____ P GREEN
PRODUCT MANAGER
EMC
DATE: 1st December 2005

Distribution:

- Copy Nos:
1. Aerial Facilities Limited
 2. TCB: TRL Compliance Services Limited.
 3. TRL EMC

THIS DOCUMENT MAY BE REPRODUCED ONLY IN ITS ENTIRETY AND WITHOUT CHANGE



CONTENTS

	PAGE		
CERTIFICATE OF CONFORMITY & COMPLIANCE	3		
APPLICANT'S SUMMARY	4		
EQUIPMENT TEST CONDITIONS	5		
TESTS REQUIRED	5		
TEST RESULTS	6-60		
		ANNEX	
PHOTOGRAPHS		A	
PHOTOGRAPH No. 1: Test setup			
PHOTOGRAPH No. 2: Test setup			
TEST EQUIPMENT CALIBRATION DETAILS		B	
SYSTEM DIAGRAM		C	
Notes:			
1. Component failure during test		YES	<input type="checkbox"/>
		NO	<input checked="" type="checkbox"/>
2. If Yes, details of failure:			
3. The facilities used for the testing of the product contain in this report are FCC Listed.			



CERTIFICATE OF CONFORMITY & COMPLIANCE

FCC IDENTITY: NEOCE-470BDA

PURPOSE OF TEST: Certification

TEST SPECIFICATION: FCC RULES CFR 47, PART 90 SUBPART I

TEST RESULT: Compliant to Specification

EQUIPMENT UNDER TEST: 60-056101 and 60-056102

EQUIPMENT TYPE: Booster

MAXIMUM GAIN
Downlink: 470MHz: 38.4dBm 483MHz :44.3dBm
Up Link: 473MHz: 59.01dBm 486MHz : 49.3dBm

MAXIMUM INPUT
Downlink: 470MHz: -6dBm 483MHz:-7dBm
Uplink: 473MHz: -74dBm 486MHz:-64dBm

MAXIMUM OUTPUT
Downlink: 470MHz: 32.4dBm 483MHz:37.3dBm
Uplink: 473MHz: -14.99dBm 486MHz:-14.7dBm

CHANNEL SPACING: 25kHz

NUMBER OF CHANNELS:
Downlink 470MHz band Down Link 483MHz Band
470.2625MHz 483.3125MHz
470.2125MHz 483.2875MHz
483.0625MHz
483.5625MHz
482.2375MHz
Uplink 473MHz Band Uplink 486MHz Band
473.2625MHz 486.3125MHz
473.2125MHz 486.2875MHz
486.0625MHz
486.5625MHz
485.2375MHz

FREQUENCY GENERATION: N/A

MODULATION TYPE: F3E

POWER SOURCE(s): 110Vac

TEST DATE(s): 12th – 16th July 2005

ORDER No(s): 31474

APPLICANT: Aerial Facilities Limited

ADDRESS: Aerial House
Asheridge Road
Chesham
Buckinghamshire
HP5 1TU
United Kingdom

TESTED BY: _____ J CHARTERS

APPROVED BY: _____ P GREEN
PRODUCT
MANAGER EMC

EQUIPMENT TEST / EXAMINATIONS REQUIRED

1.	TEST/EXAMINATION	RULE PART	APPLICABILITY	RESULT
	RF Gain	90.205 2.1046	Yes	Complies
	Audio Frequency Response	TIA EIA-603.3.2.6	N/A	N/A
	Audio Low-Pass Filter Response	TIA EIA-603.3.2.6	N/A	N/A
	Modulation Limiting	TIA EIA-603.3.2.6	N/A	N/A
	Occupied Bandwidth	90.210 2.1049	Yes	Complies
	Spurious Emissions at Antenna Terminals	90.210	Yes	Complies
	Field Strength of Spurious Emissions	90.210 2.1053	Yes	Complies
	Frequency Stability	90.213	N/A	N/A (Note 1)
	Transient behaviour	90.214	N/A	N/A (Note 1)

Notes:

1 The EUT does not contain modulation circuitry, therefore the test was not performed.

2 The EUT does not contain any switching circuitry, therefore the test was not performed.

- 2. Product Use: Cell enhancer
- 3. Emission Designator: F3E
- 4. Temperatures: Ambient (Tnom) 26°C
- 5. Supply Voltages: Vnom 110Vac

Note: Vnom voltages are as stated above unless otherwise shown on the test report page

- 6. Equipment Category:
 - Single channel []
 - Two channel []
 - Multi-channel [X]
- 7. Channel spacing:
 - Narrowband [X]
 - Wideband []
- 8. Test Location
 - TRL Compliance Services
 - Up Holland [X]
 - Long Green []
- 9. Modifications made during test program No modifications were performed.
- 10. System description

The 60-056101 and 60-56102 are intended to be used as part of a larger system. They are broadband boosters with the channel filtering occurring at the above ground air interface. See Annex C for a system diagram.

COMPLIANCE TESTS

TRANSMITTER TEST – GAIN – CONDUCTED – PART 2.1046 – DOWNLINK

Ambient temperature = 18°C Radio Laboratory
 Relative humidity = 41%
 Supply voltage = 110Vac
 Channel number = See test results

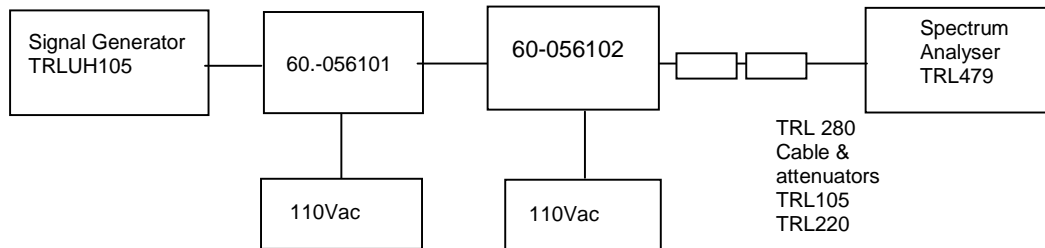

Frequency MHz	Signal Generator Input Level dBm	Cable & attenuator Loss dB	Level at Spectrum Analyser dBm	Gain dB	Gain after 10dB increase input signal level dBm	Measured Output power dBm
469.5	-6.0	46.6	-15.76	36.84	29.5	30.84
469.95	-6.0	46.6	-15.71	36.89	28.5	30.89
470.4	-6.0	46.6	-14.2	38.4	29.0	32.4
482.2	-7.0	46.6	-9.46	44.14	37.4	37.14
482.9	-7.0	46.6	-9.27	44.33	37.8	37.33
483.6	-7.0	46.6	-10.8	42.8	36.95	35.8

The test was setup as above. The signal generator was to simulate an input signal to the system from a transmitter and the analyzer used to obtain the output level from the system.

TYPE OF EQUIPMENT	MAKER/SUPPLIER	MODEL No	SERIAL No	TRL No	ACTUAL EQUIPMENT USED
SPECTRUM ANALYSER	ANRITSU	MS266C	MT26089	479	X
ATTENUATOR	BIRD	8302	N/A	105	X
ATTENUATOR	BIRD	8304-300-N	N/A	220	X
CABLE	ROSENBERGER	MICRO COAX	N/A	280	X
SIGNAL GENERATOR	MARCONI	2023	112224/040	UH105	X

**TRANSMITTER TEST - INTERMODULATION SPURIOUS EMISSIONS – CONDUCTED – PART 2.1053–
DOWNLINK**

Ambient temperature = 24°C
 Relative humidity = 43%
 Supply voltage = 110Vac

Radio Laboratory

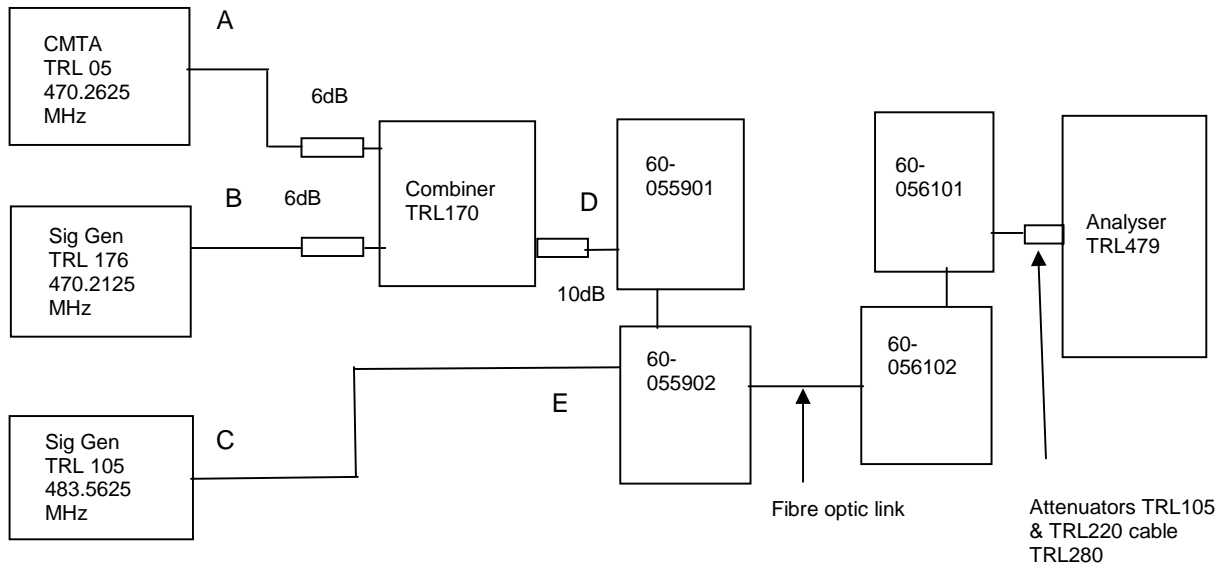

Due to the fact that the units under test will only ever be operated as a system with the channel filters contained within units 60-055901 and 60-55902. The intermodulation products test was performed as a system. The diagram above shows the setup that produced the worst case products. The intermodulation and spurious products were measured with the fibre optic system operating at maximum input level. A three tone test was conducted using the equipment as above. The input power level was adjusted so the level at point D was the maximum input -52dBm and at point E was the maximum input of -62.0dBm.

Sweep data is shown on the next page:
 See Annex C for system diagram.

Test equipment used for intermodulation test

TYPE OF EQUIPMENT	MAKER/SUPPLIER	MODEL No	SERIAL No	TRL No	ACTUAL EQUIPMENT USED
SPECTRUM ANALYSER	ANRITSU	MS2665C	MT26089	479	X
SIGNAL GENERATOR	MARCONI	2042	119562/02	254	X
CMTA	ROHDE & SCHWARZ	CMTA52	894715/033	05	X
SIGNAL GENERATOR	MARCONI	2023	112224/040	UH105	X
COMBINER	ELCOM	RC-4-50	N/A	170	x

Intermodulation Inband

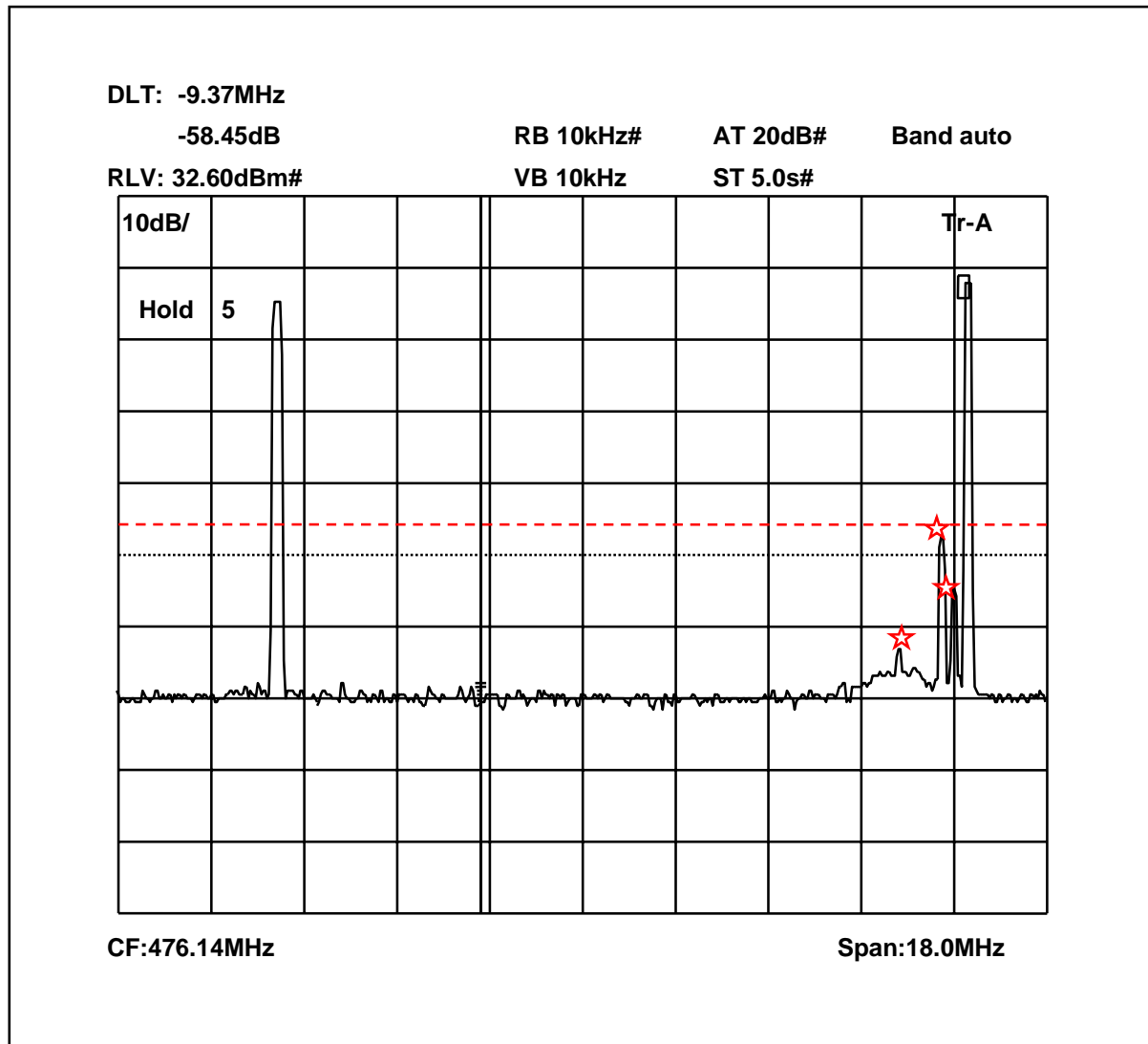

The above plot shows that all products (designated by ☆) are at least 5dB below the spurious limit. Based the 10dB above the on the -62dBm and -72dBm input to the system.

Intermodulation Wideband

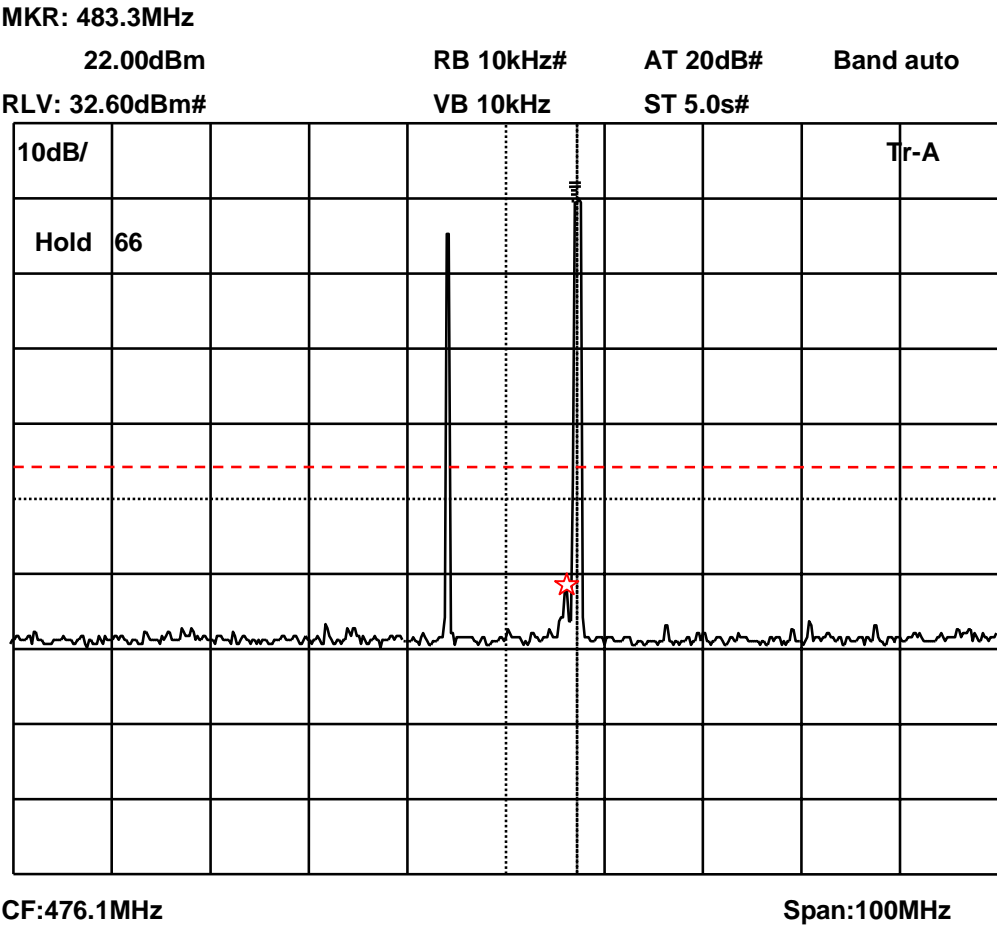

The above plot shows that all products (designated by ☆) are at least 10dB below the spurious limit. Based the 10dB above the on the -62dBm and -72dBm input to the system.

TRANSMITTER TESTS

MODULATED BANDWIDTH TEST – CONDUCTED – Part 2.1049– DOWNLINK

Ambient temperature	= 18°C	Radio Laboratory
Relative humidity	= 40%	
Supply voltage	= 110Vac	
Channel number	= See test results	

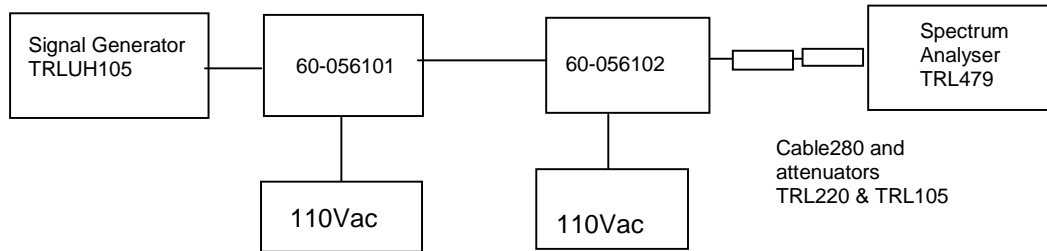

This test was performed to show that the fibre optic system does not alter the input signal in any way. The input signal was set to the maximum input level (-6dBm) and modulated with a 2500Hz tone. The plots show the signal measured at the signal generator and the signal measured at the output of the EUT.

Note: The cables and attenuators had the following losses.

1. Cable TRL280 and Attenuators TRL220,TRL 105 between EUT and spectrum analyser= 46.6dB
2. Cable between signal generator and EUT = 0.22dB

TYPE OF EQUIPMENT	MAKER/SUPPLIER	MODEL No	SERIAL No	TRL No	ACTUAL EQUIPMENT USED
SPECTRUM ANALYSER	ANRITSU	MS2665C	MT26089	479	X
ATTENUATOR	BIRD	8304-200	N/A	105	X
ATTENUATOR	BIRD	8304-300-N	N/A	220	X
CABLE	ROSENBERGER	MICRO COAX	N/A	280	X
SIGNAL GENERATOR	MARCONI	2023	112224/040	UH105	X

469.50MHz Signal Generator deviation set to 5kHz

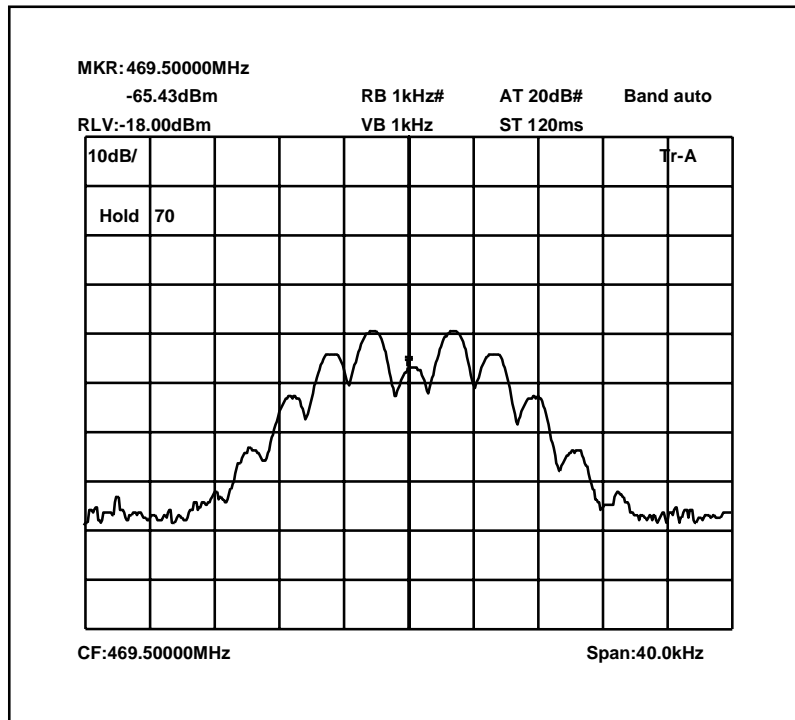

469.50MHz Signal Generator and amplifier deviation set to 5kHz

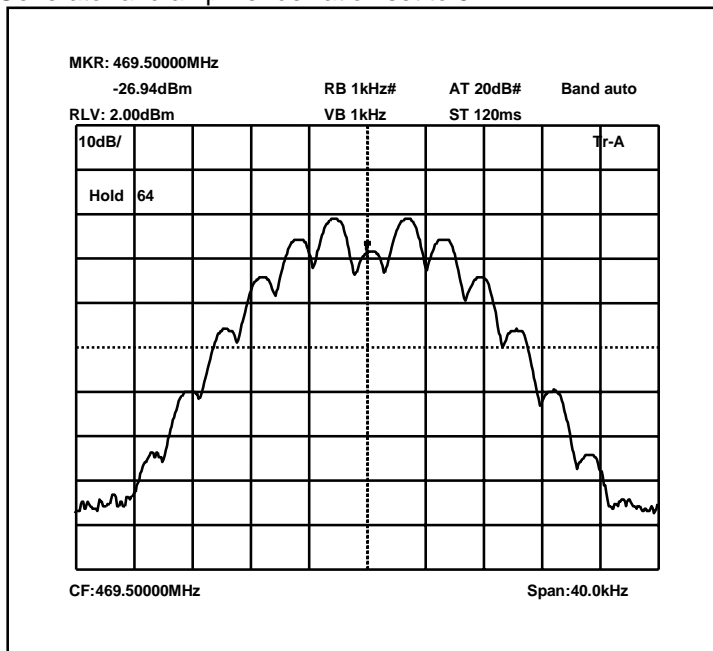

The above plots depicting the output waveshape show no measurable distortion visible when compared to the input signal.

469.95MHz Signal Generator deviation set to 5kHz

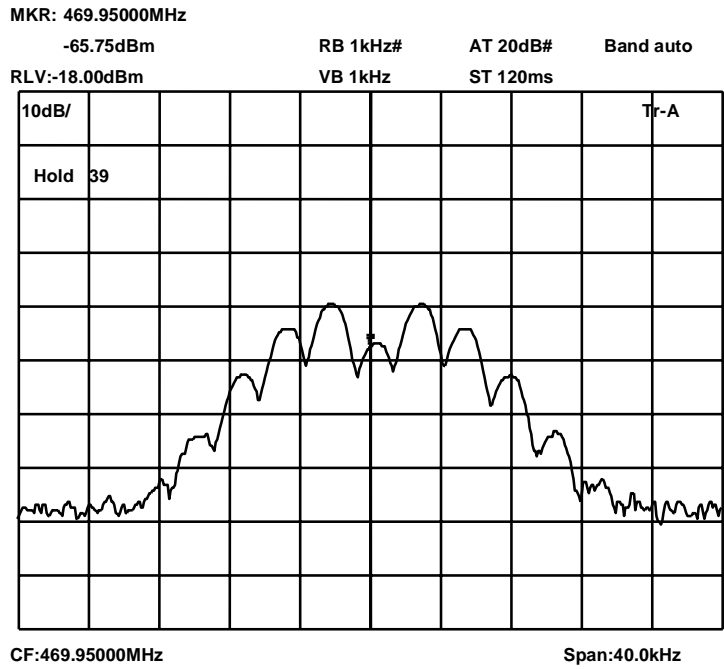

469.95MHz Signal Generator and amplifier deviation set to 5kHz

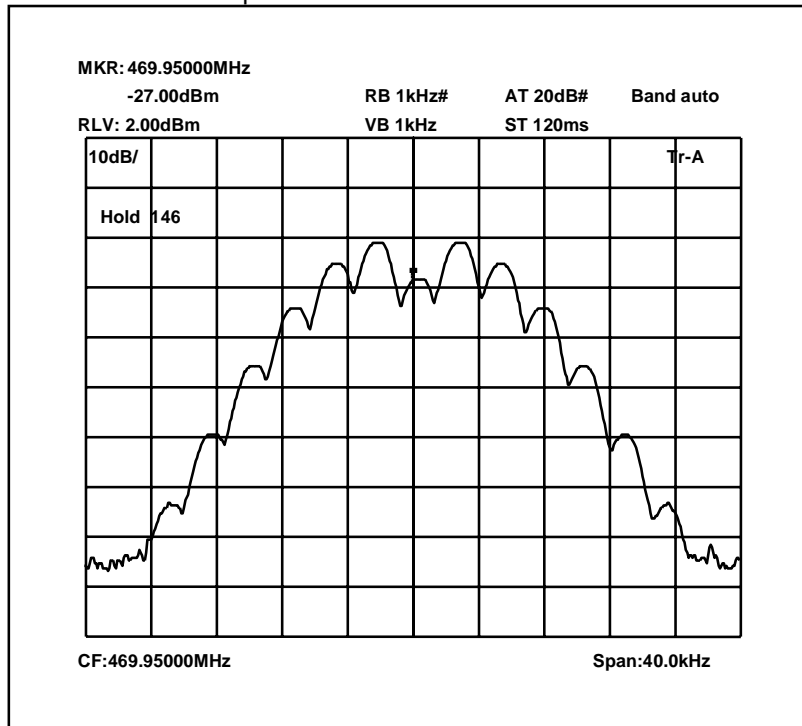

The above plots depicting the output waveshape show no measurable distortion visible when compared to the input signal.

470.4MHz Signal Generator deviation set to 5kHz

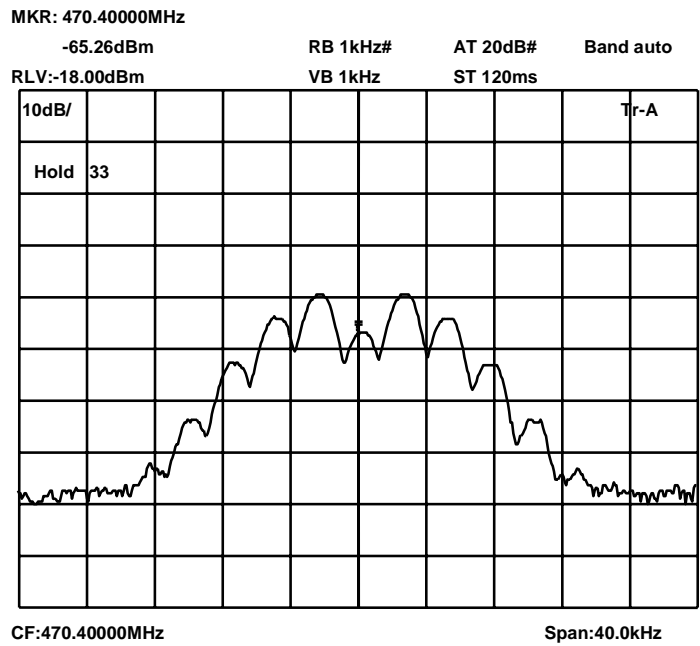

470.4MHz Signal Generator and amplifier system deviation set to 5kHz

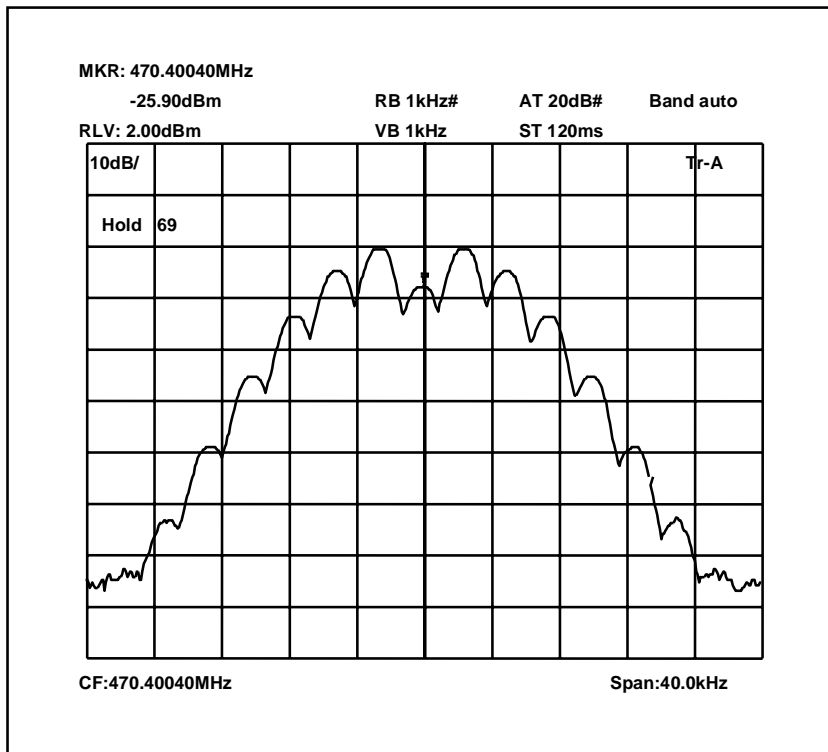

The above plots depicting the output waveshape show no measurable distortion visible when compared to the input signal.

482.2375MHz Signal Generator deviation set to 5kHz

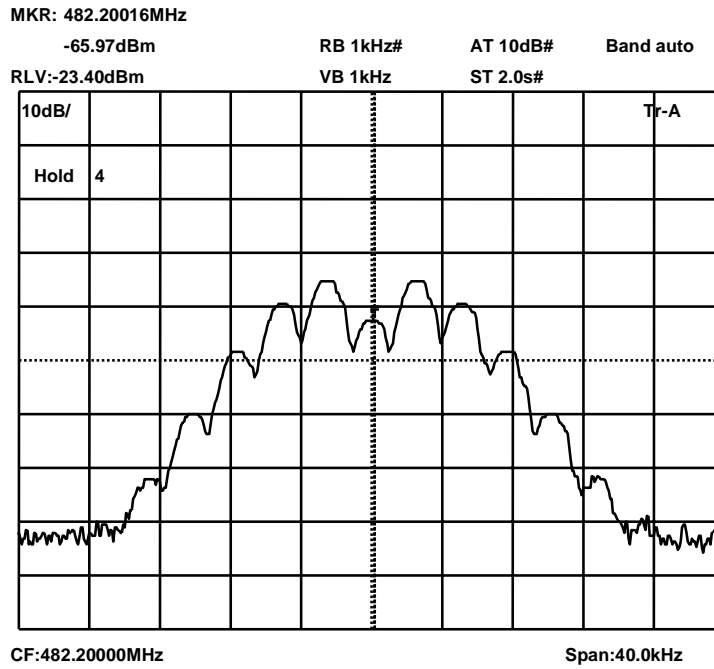

482.2375MHz Signal Generator and amplifier system deviation set to 5kHz

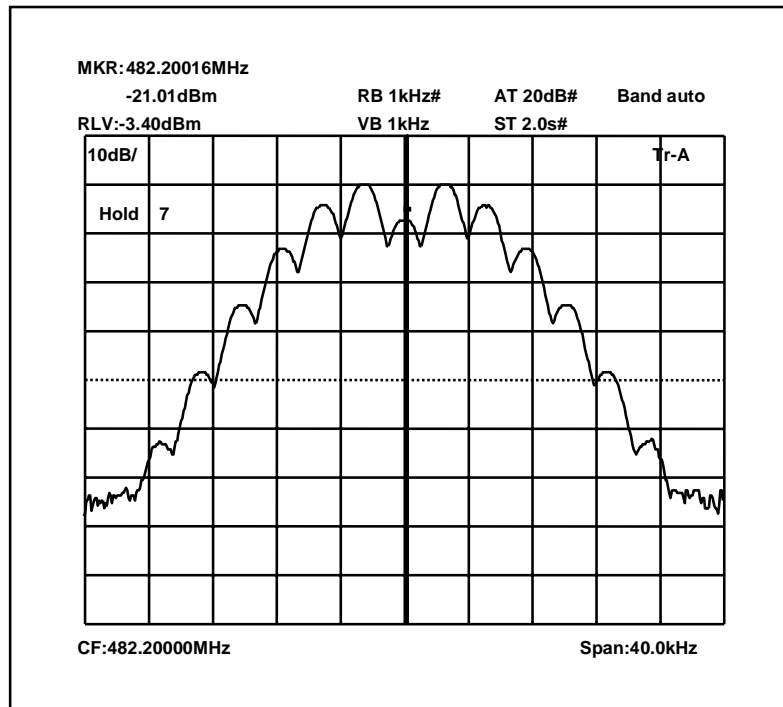

The above plots depicting the output waveshape show no measurable distortion visible when compared to the input signal.

482.9MHz Signal Generator deviation set to 5kHz

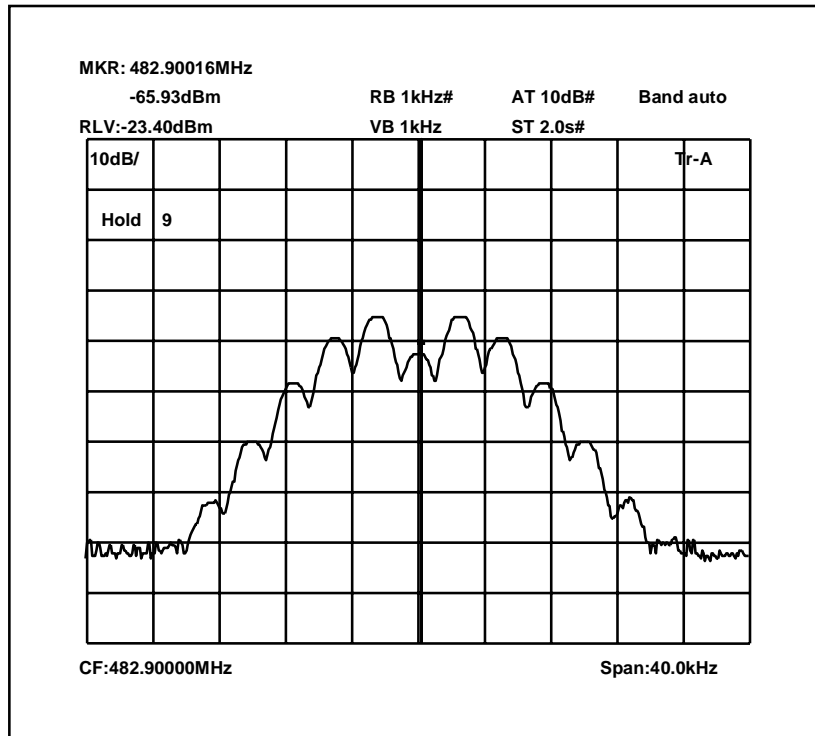

482.9MHz Signal Generator and amplifier system deviation set to 5kHz

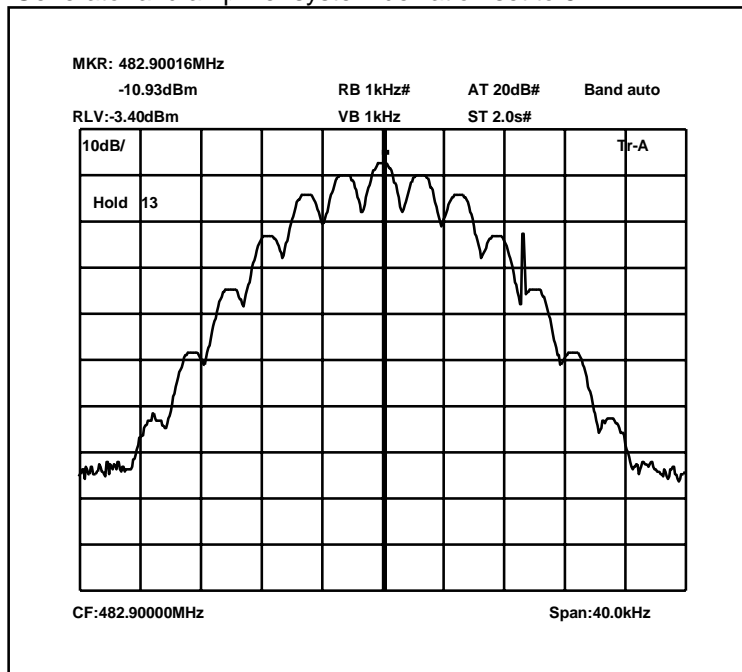

The above plots depicting the output waveshape show no measurable distortion visible when compared to the input signal.

483.6MHz Signal Generator deviation set to 5kHz

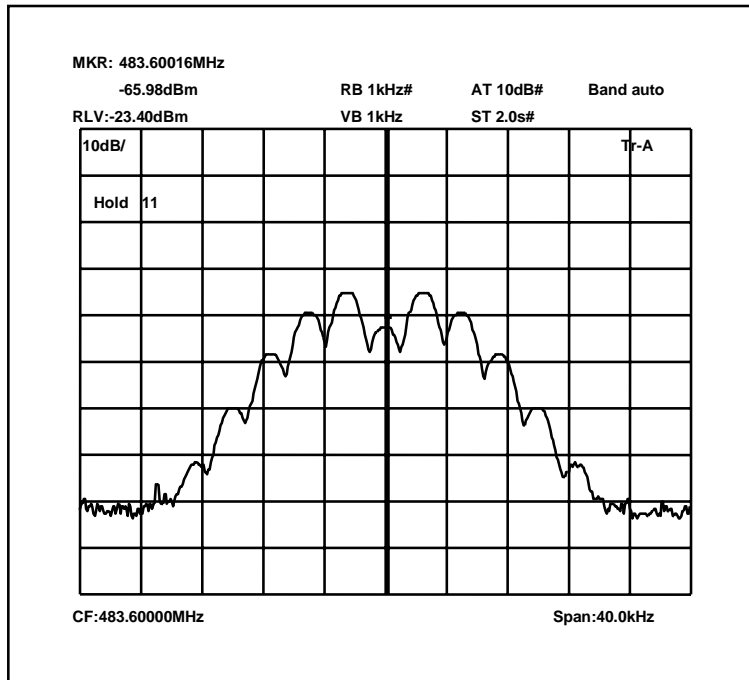

483.6MHz Signal Generator and amplifier system deviation set to 5kHz

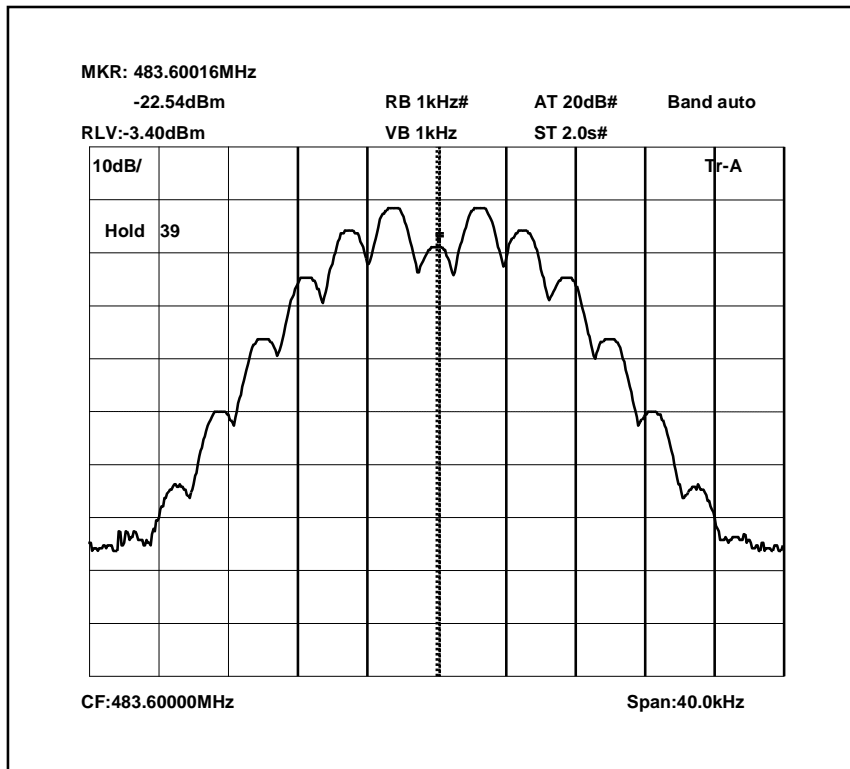

The above plots depicting the output wavsshape show no measurable distortion visible when compared to the input signal.

TRANSMITTER TESTS

TRANSMITTER SPURIOUS EMISSIONS – CONDUCTED – Part 2.1053 – DOWNLINK

Ambient temperature = 18°C
 Relative humidity = 40%
 Supply voltage = 110Vac

Radio Laboratory Test Signal = F3E

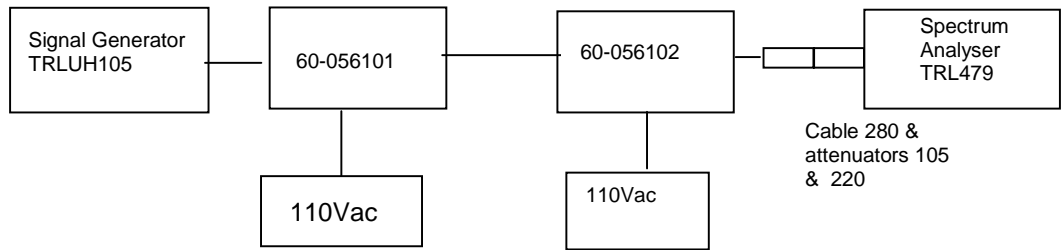

The test was set up as per the diagram. The level at the input was adjusted to compensate for the loss of the interconnecting cable. The unit was tested operating at maximum power and on three test frequencies.

The spurious limit was calculated as follows:

On any frequency removed from the assigned frequency by more than 250% of the authorised bandwidth

At least 43 + 10 log PdB

$$(10\log P_{\text{watts}}) - (43 + 10\log (P_{\text{watts}} * 1000)) = \text{LIMIT} = -13 \text{ dBm}$$

Results

No significant emissions were detected within 20dBm of limit.

The test equipment used for the Transmitter Conducted Emissions:

TYPE OF EQUIPMENT	MAKER/SUPPLIER	MODEL No	SERIAL No	TRL No	ACTUAL EQUIPMENT USED
SPECTRUM ANALYSER	ANRITSU	MS2665C	MT26089	479	X
ATTENUATOR	BIRD	8304-200	N/A	105	X
ATTENUATOR	BIRD	8304-300-N	N/A	220	X
CABLE	ROSENBERGER	MICRO COAX	N/A	280	X
SIGNAL GENERATOR	MARCONI	2023	112224/040	UH105	X

Conducted emissions 469.5 MHz 0 – 2 GHz

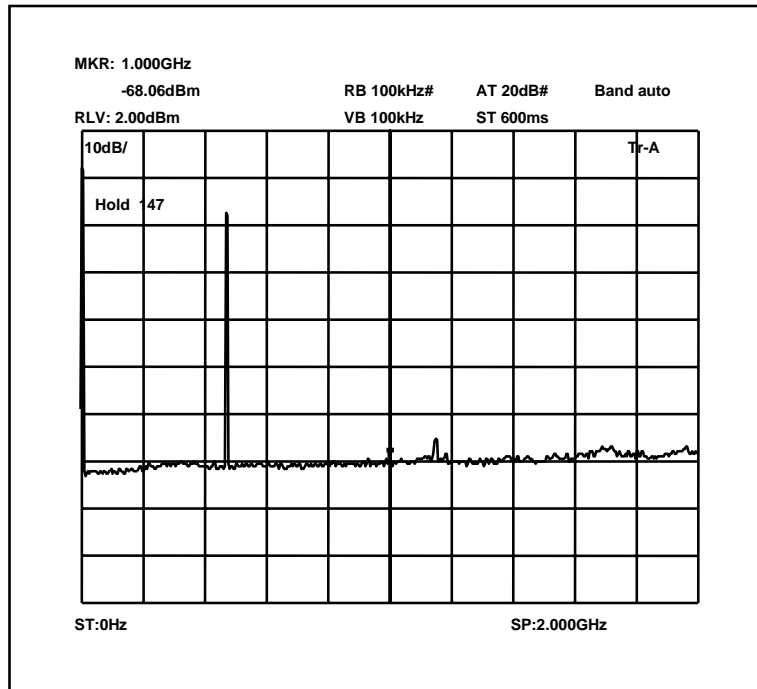

Conducted emissions 469.5MHz 2 – 5 GHz

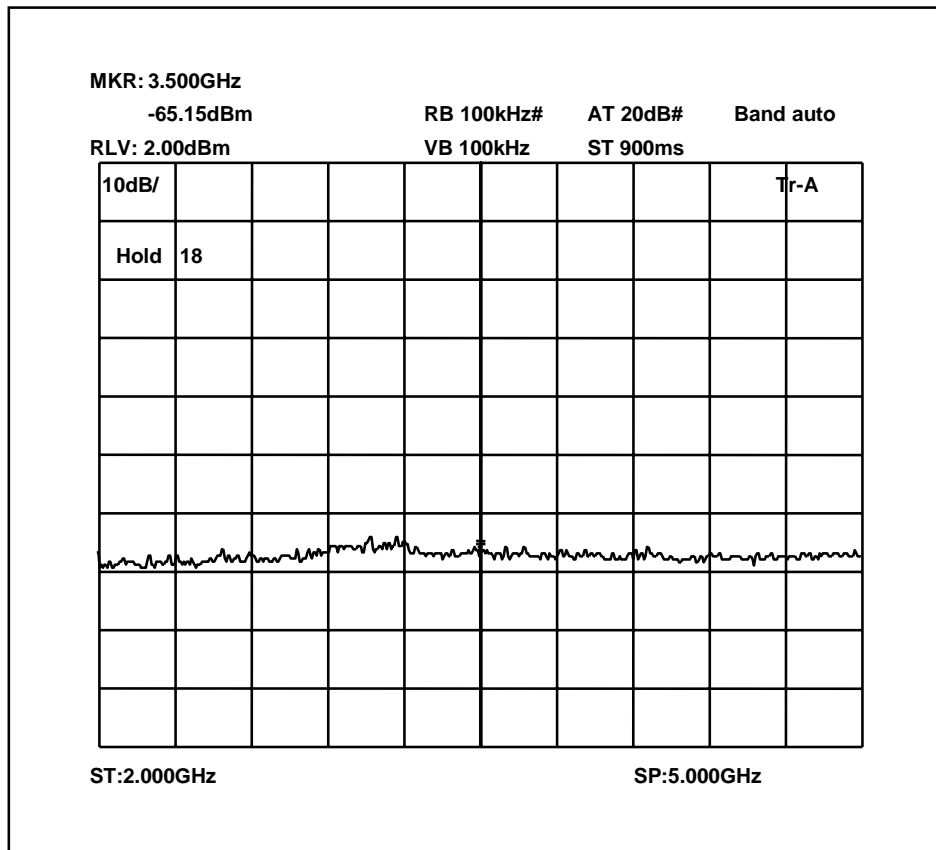

Conducted emissions 469.95MHz 0 – 2.0 GHz

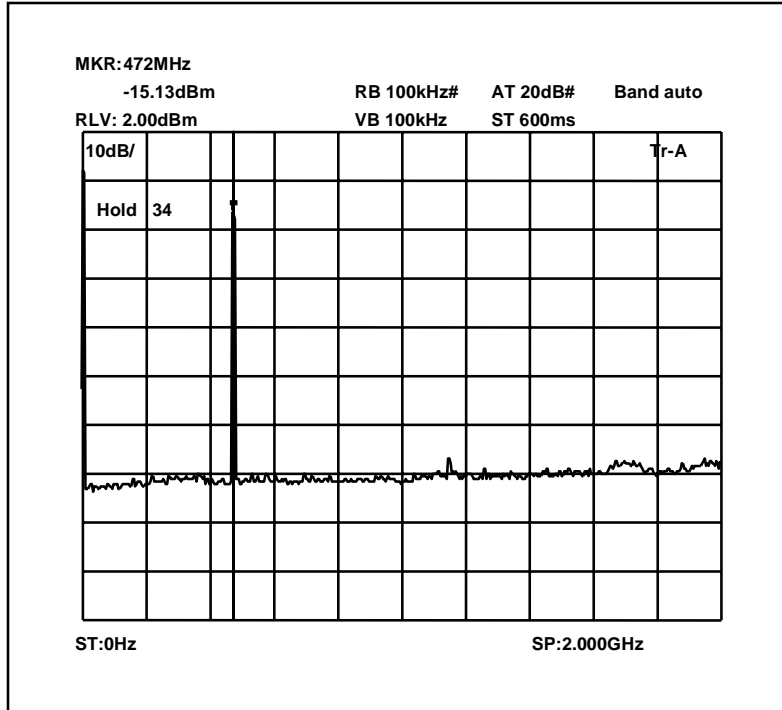

Conducted emissions 469.95MHz 2.0 – 5.0 GHz

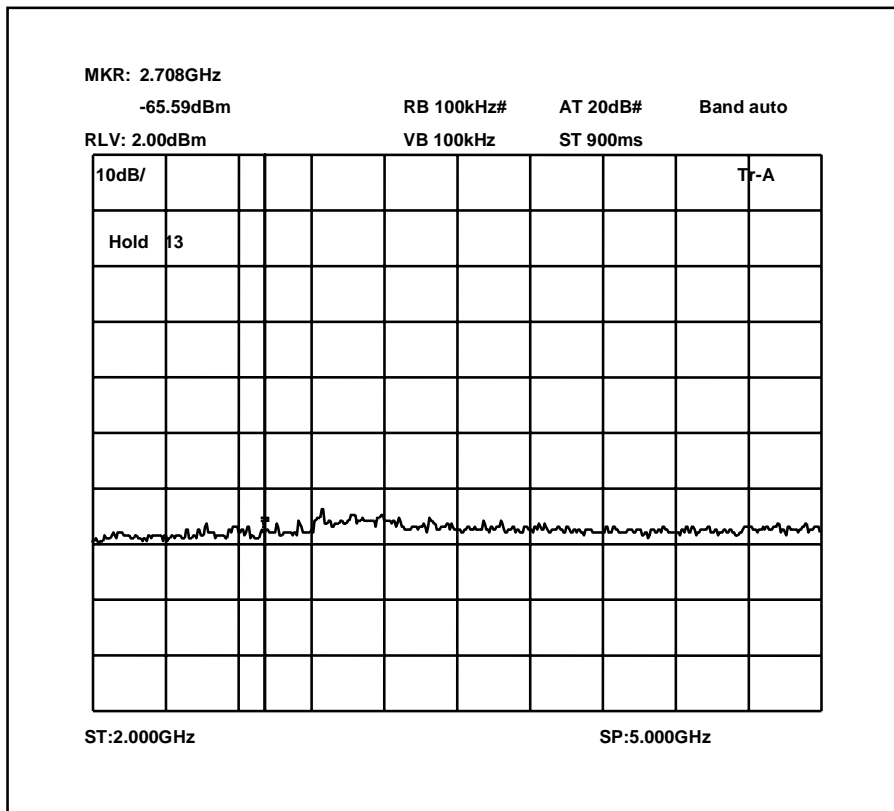

Conducted emissions 470.4MHz 0 – 2 GHz

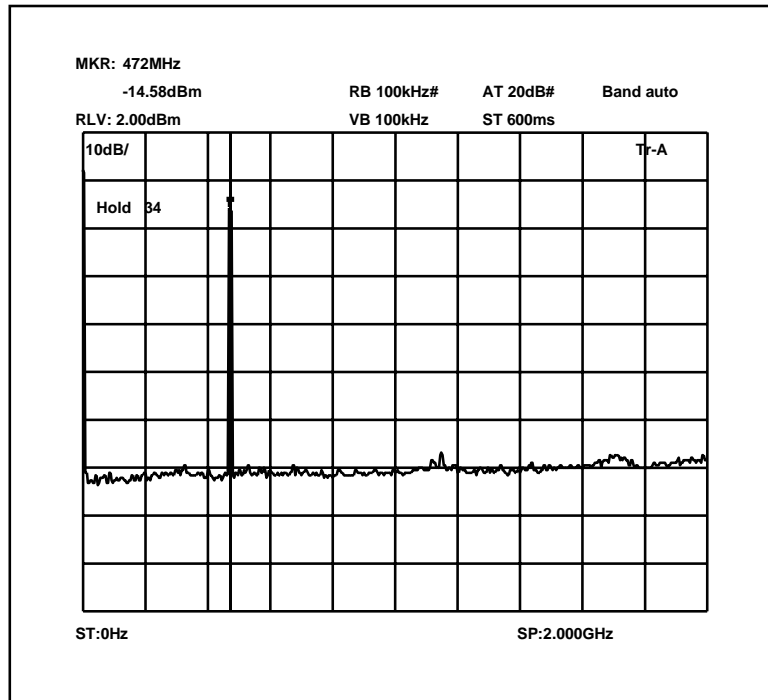

Conducted emissions 470.4MHz 2 – 5 GHz

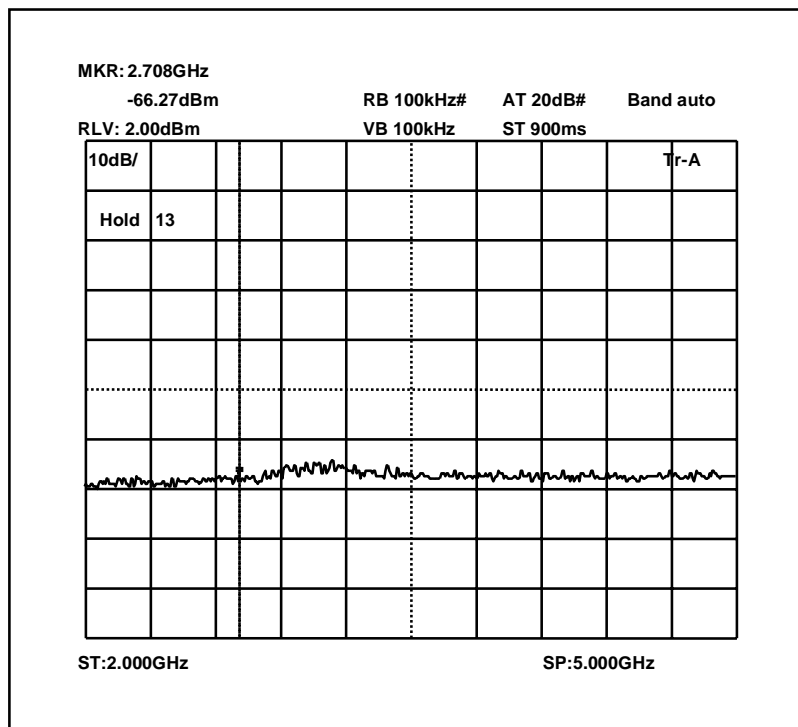

Conducted emissions 482.2MHz 0 – 2 GHz

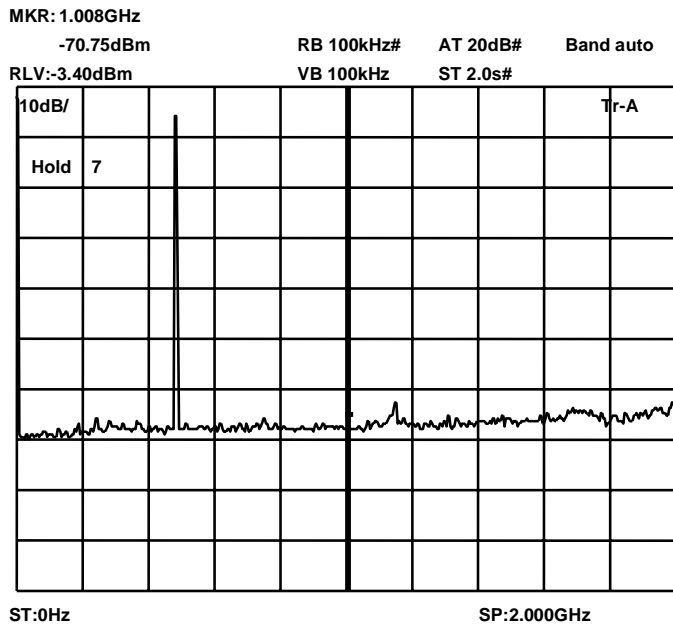

Conducted emissions 482.2MHz 2 – 5 GHz

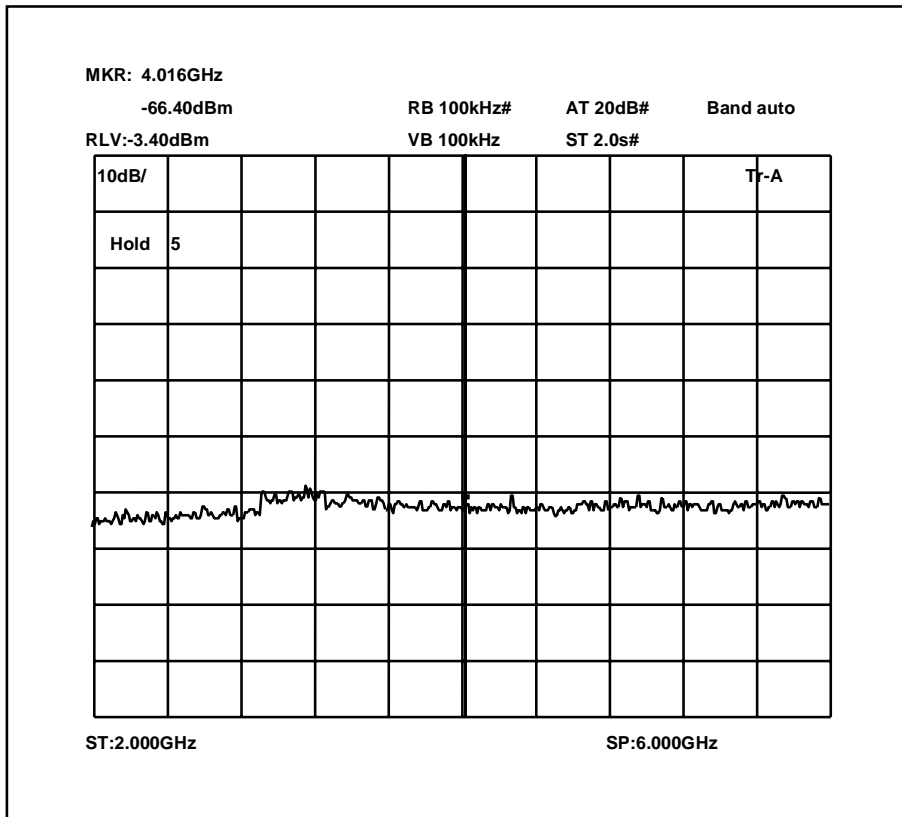

Conducted emissions 482.9MHz 0 – 2 GHz

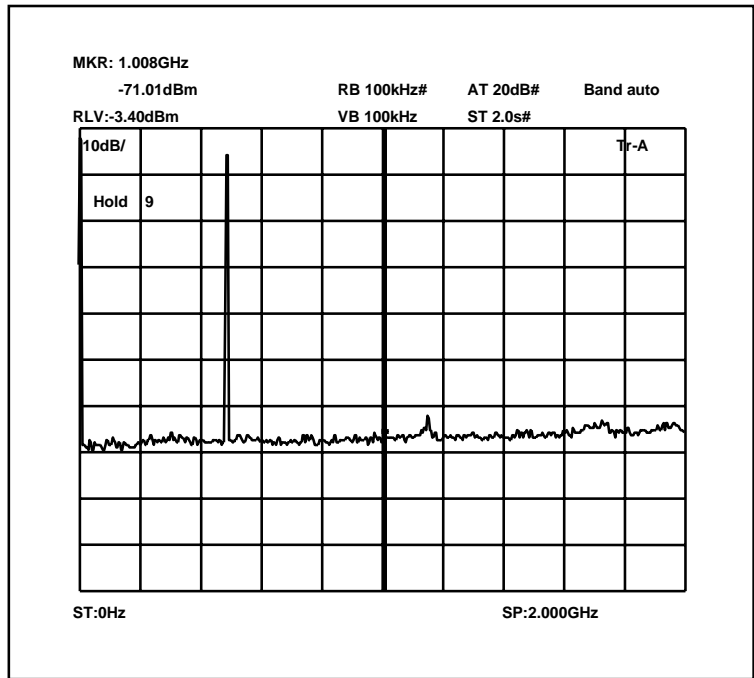

Conducted emissions 482.9MHz 2 – 5 GHz

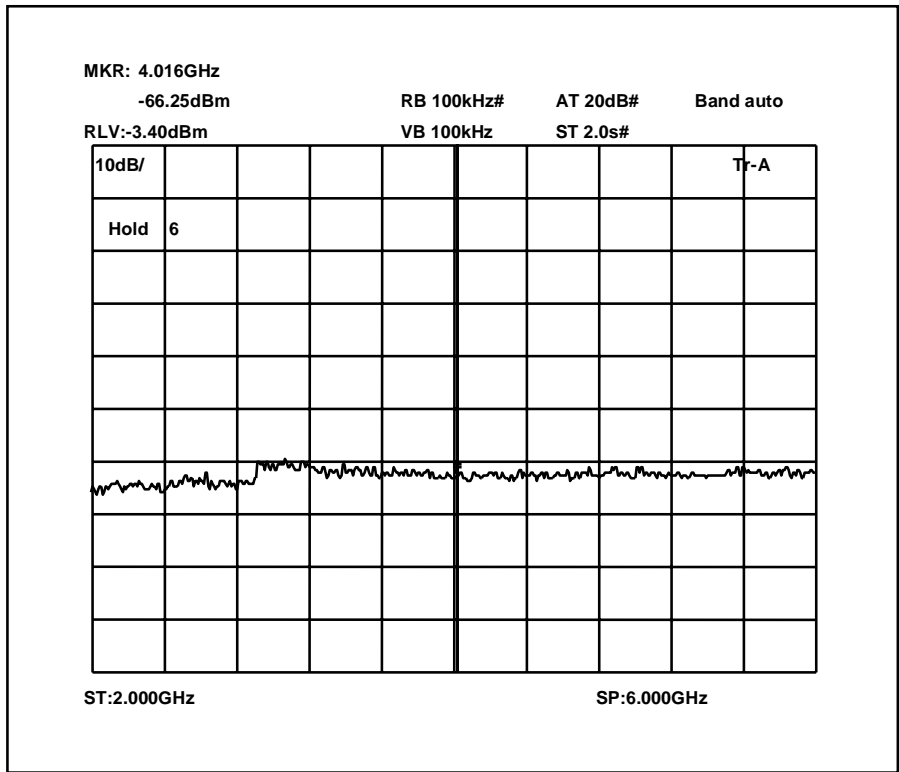

Conducted emissions 483.6MHz 0 – 2 GHz

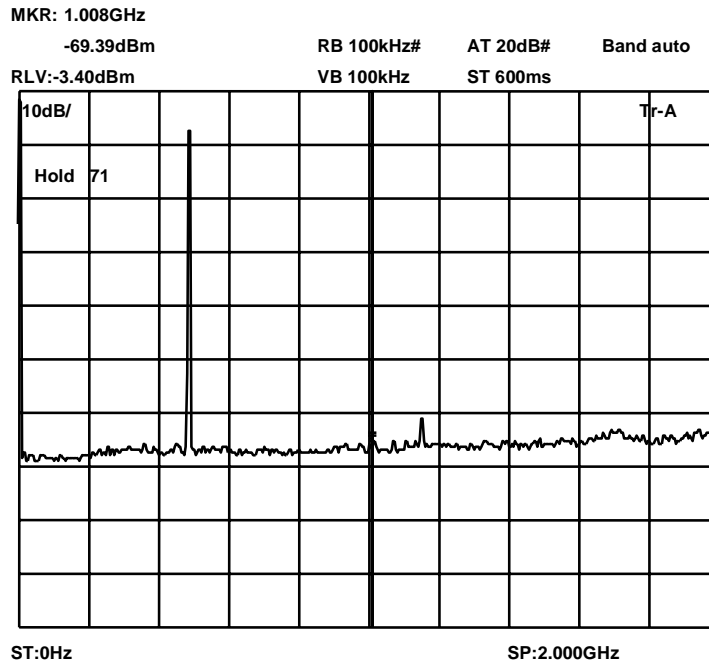

Conducted emissions 483.6MHz 2 – 5 GHz

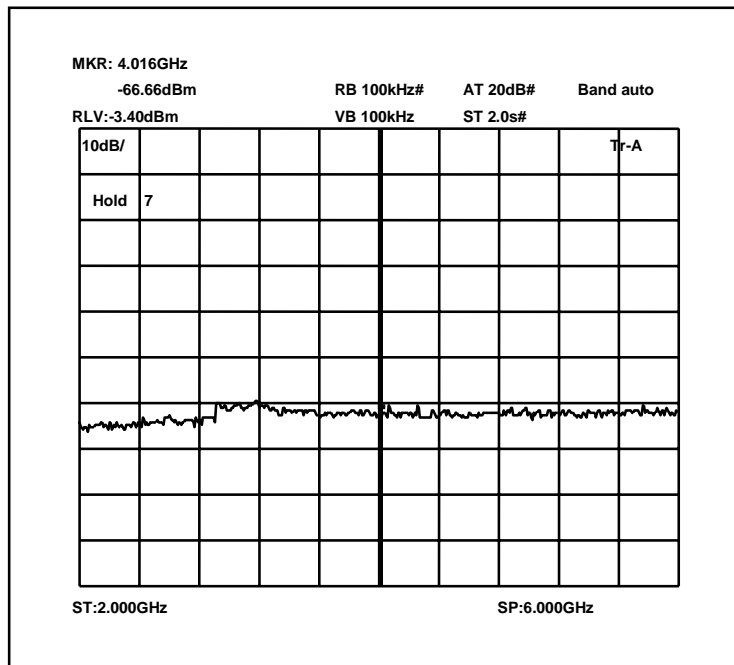

TRANSMITTER TESTS

TRANSMITTER SPURIOUS EMISSIONS – RADIATED – Part 2.1053– DOWNLINK

Ambient temperature = 21°C
 Relative humidity = 50%
 Conditions = OATS
 Supply voltage = 110Vac
 Supply Frequency = N/A

Test Signal = F3E

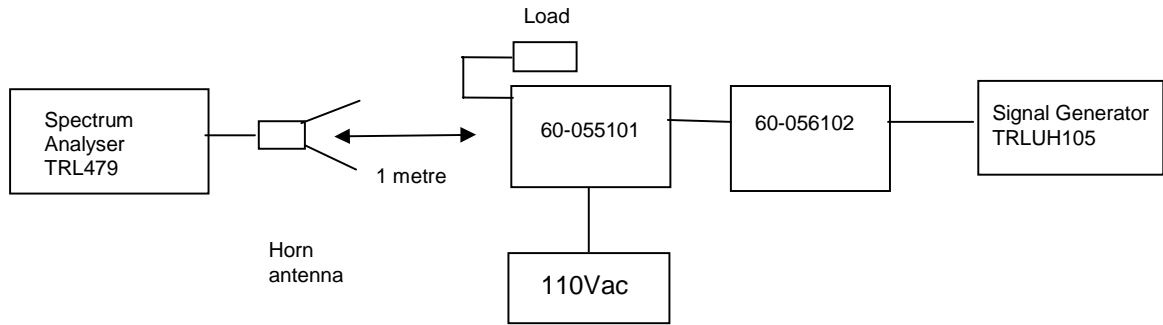

The test was set up as per the diagram. The level at the input was adjusted to compensate for the loss of the interconnecting cable. The unit was tested operating maximum power on three test frequencies with a 50 ohm load on the output. The unit was also tested with the signal generator replaced by another 50ohm load.

The Spurious limit was calculated as follows:

On any frequency removed from the assigned frequency by more that 250% of the authorised bandwidth

At least 43 + 10 log PdB

$$(10\log P_{\text{watts}}) - (43+10\log (P_{\text{watts}} * 1000)) = \text{LIMIT} = -13 \text{ dBm}$$

Test result

No significant emissions with 20dBm of limit.

The test equipment used for the Transmitter Spurious Emissions:

TYPE OF EQUIPMENT	MAKER/SUPPLIER	MODEL No	SERIAL No	TRL No	ACTUAL EQUIPMENT USED
SPECTRUM ANALYSER	ANRITSU	MS2665C	MT26089	479	X
HORN	EMCO	3115	9010-3581	139	X
ATTENUATOR	BIRD	8304-300-N	N/A	220	X
ATTENUATOR	BIRD	8308-100	N/A	112	X
CABLE	ROSENBERGER	MICRO COAX	N/A	280	X
SIGNAL GENERATOR	MARCONI	2023	112224/040	UH105	X

Radiated emissions 469.50MHz 0 – 2GHz

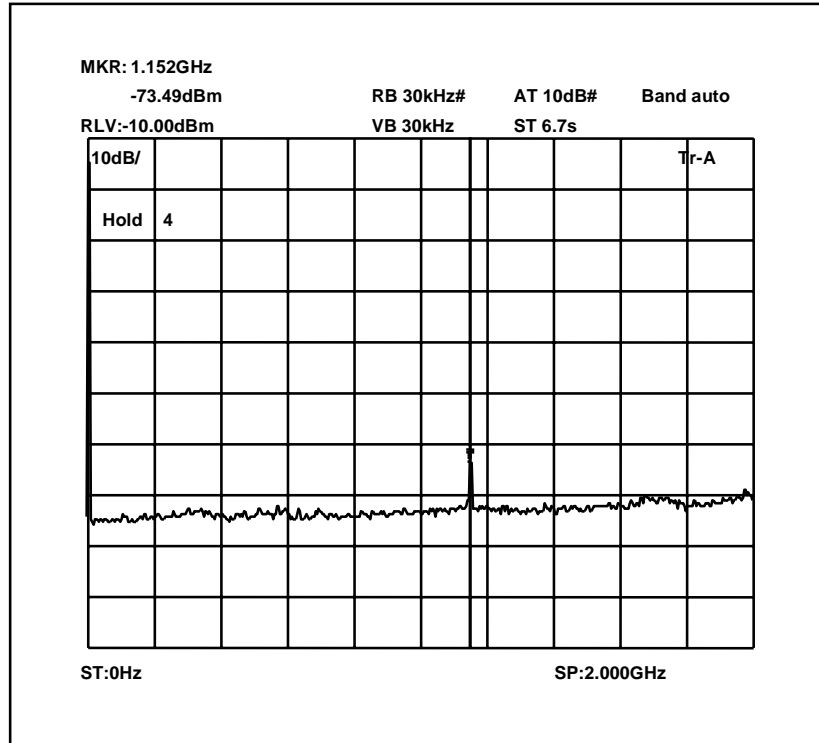

Radiated emissions 469.5 MHz 2-5GHz

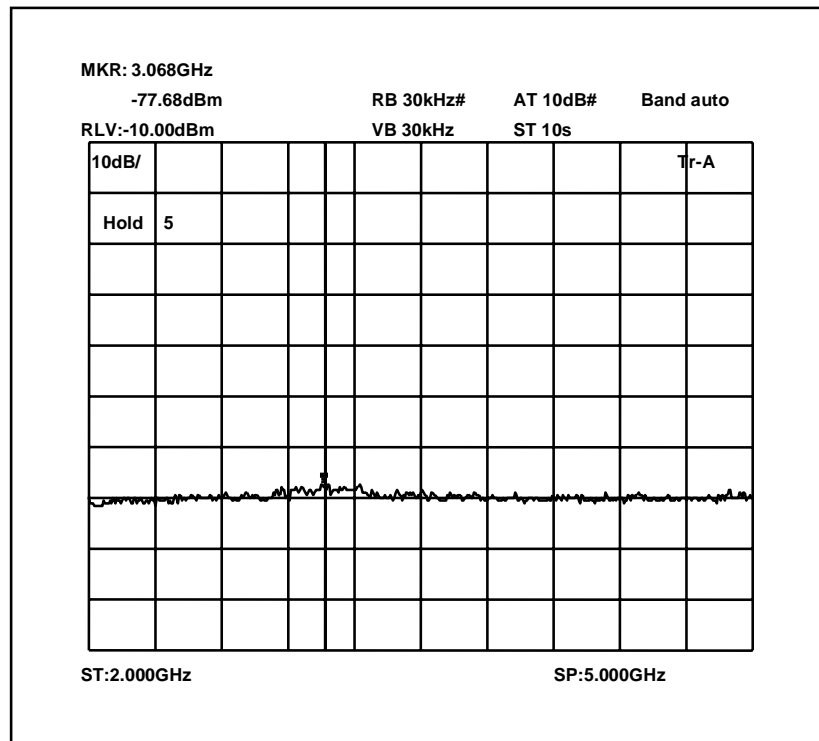

The above test results show that there were no emissions within 20dBs of the -13dBm limit.

Radiated emissions 469.95MHz 0 -2GHz

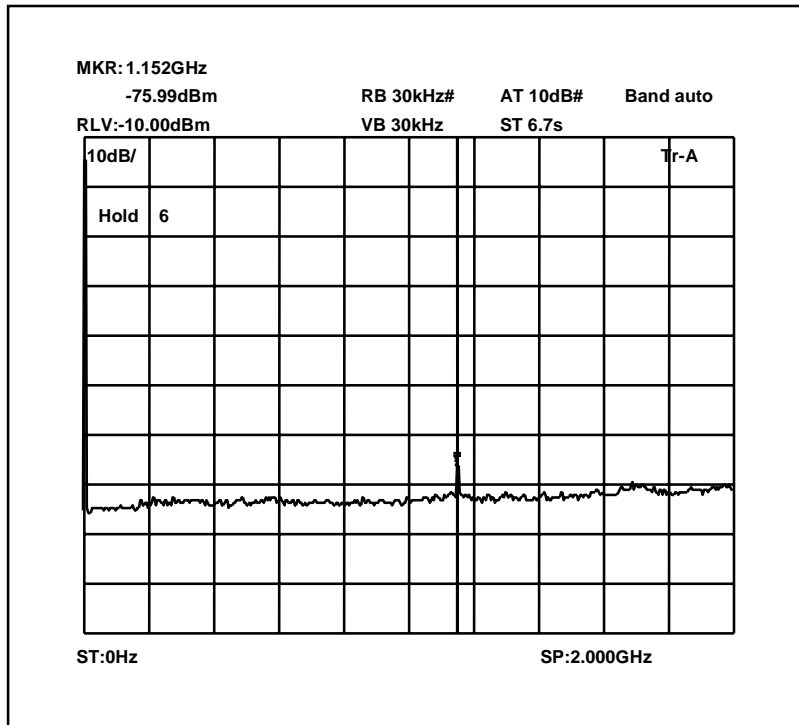

Radiated emissions 469.95MHz 2-5 GHz

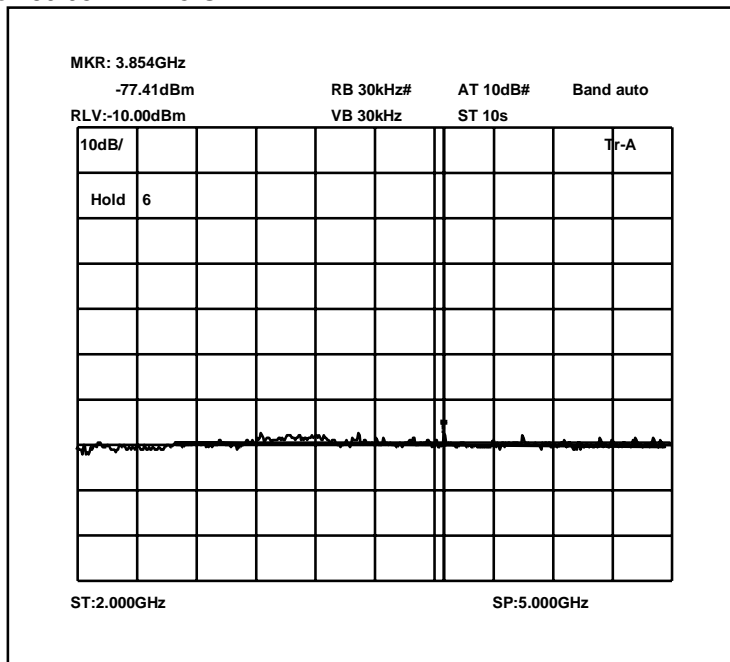

The above test results show that there were no emissions within 20dBs of the -13dBm limit.

Radiated emissions 470.4MHz 0 -2 GHz

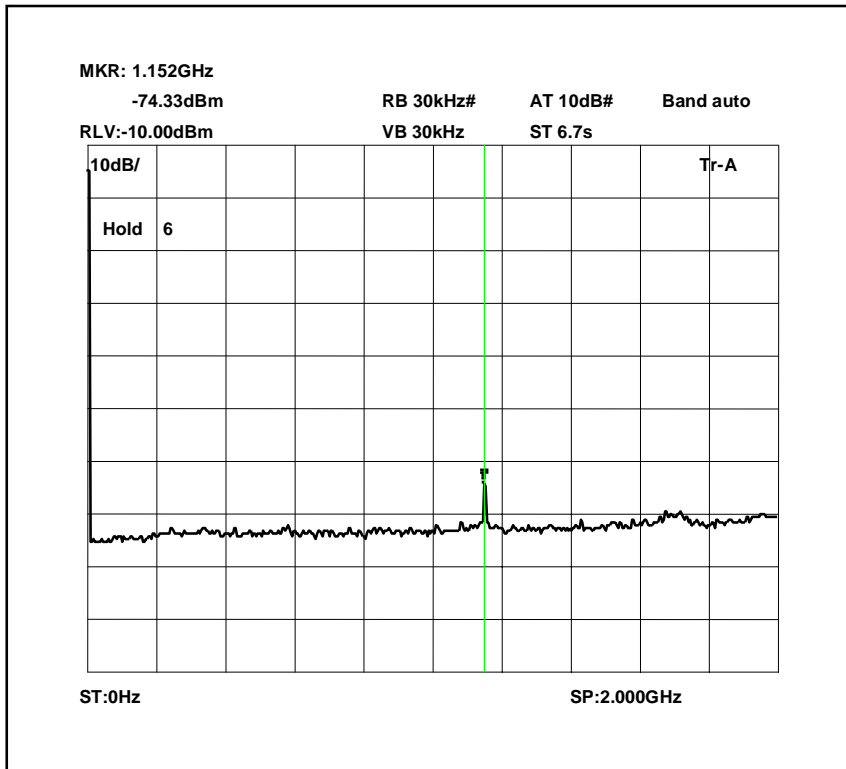

Radiated emissions 470.4MHz 2 – 5GHz

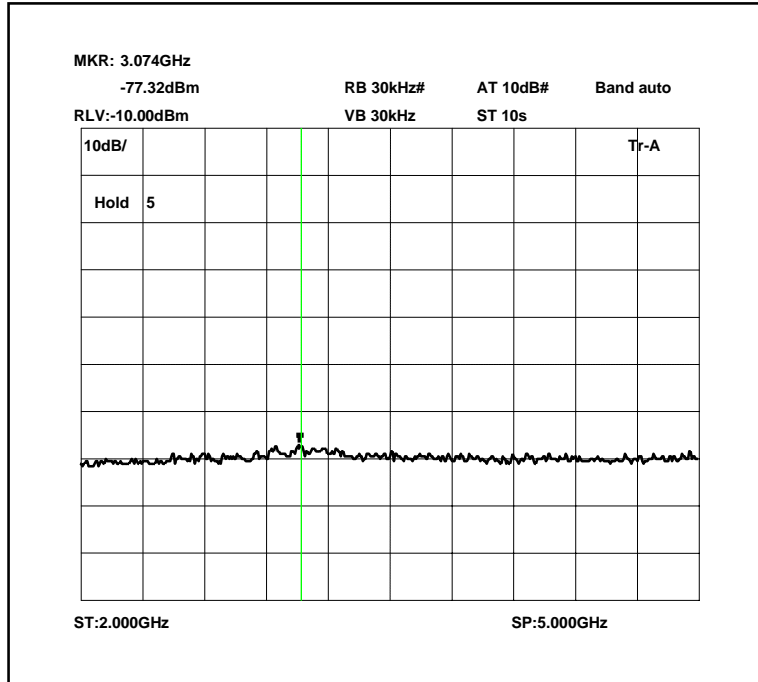

The above test results show that there were no emissions within 20dBs of the -13dBm limit.

Radiated emissions 482.2MHz 0 -2 GHz

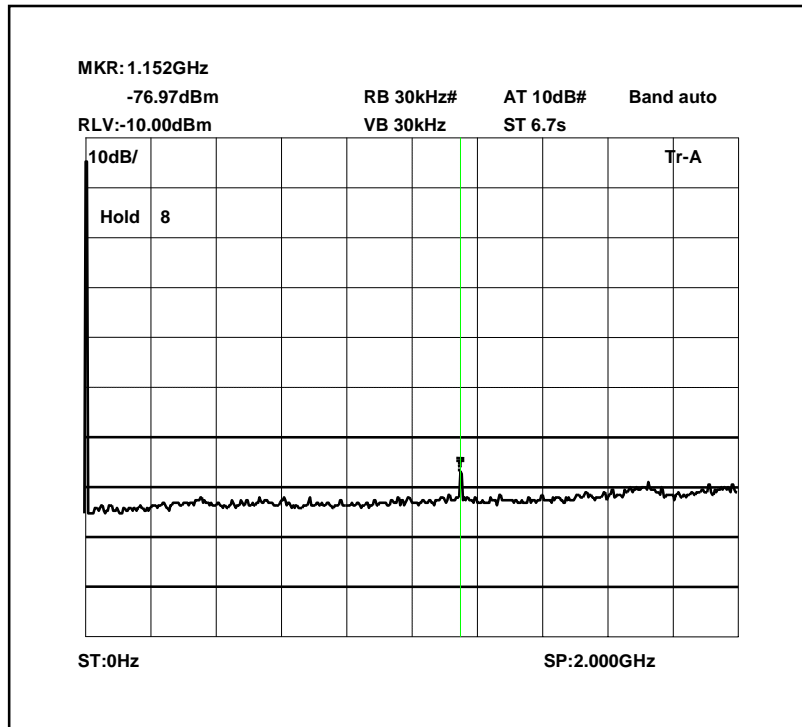

Radiated emissions 482.2MHz 2 – 5GHz

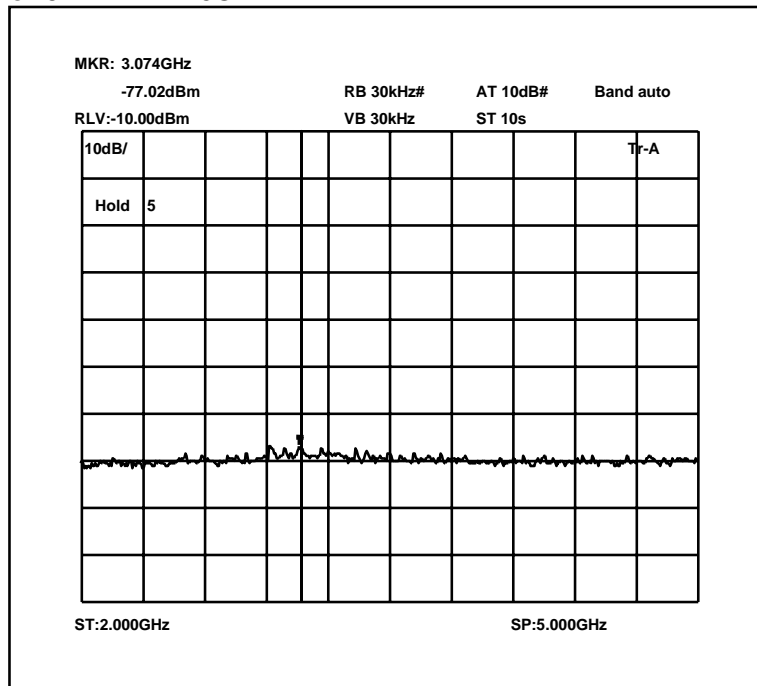

The above test results show that there were no emissions within 20dBs of the -13dBm limit.

Radiated emissions 482.9MHz 0 -2 GHz

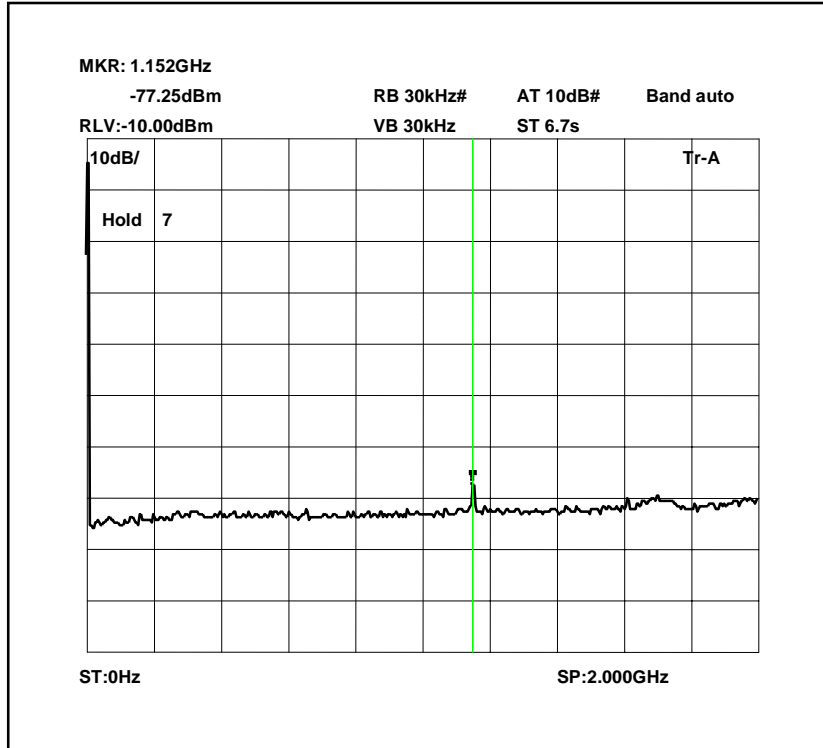

Radiated emissions 482.9MHz 2 – 5GHz

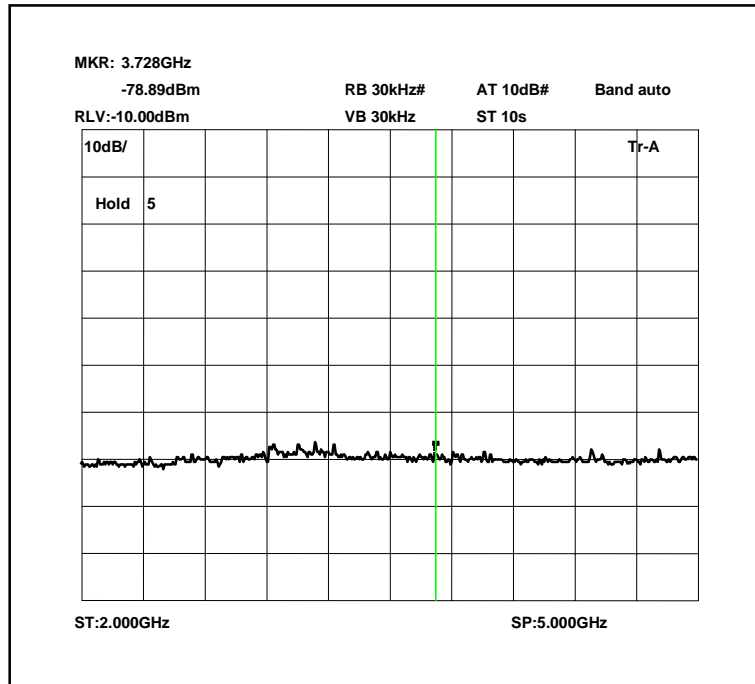

The above test results show that there were no emissions within 20dBs of the -13dBm limit.

Radiated emissions 483.6MHz 0 -2 GHz

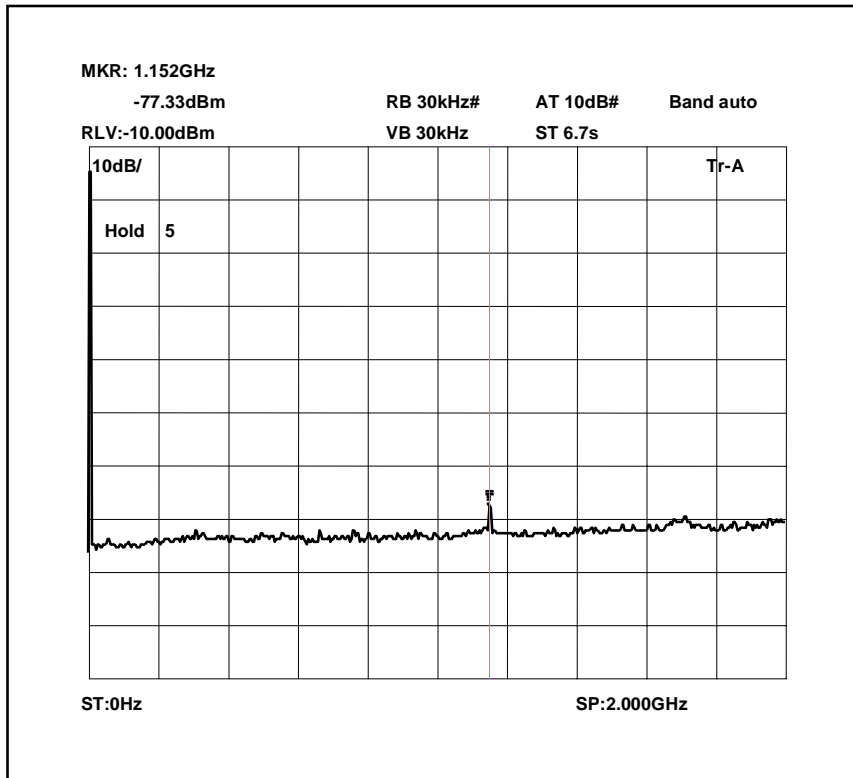

Radiated emissions 483.6MHz 2 – 5GHz

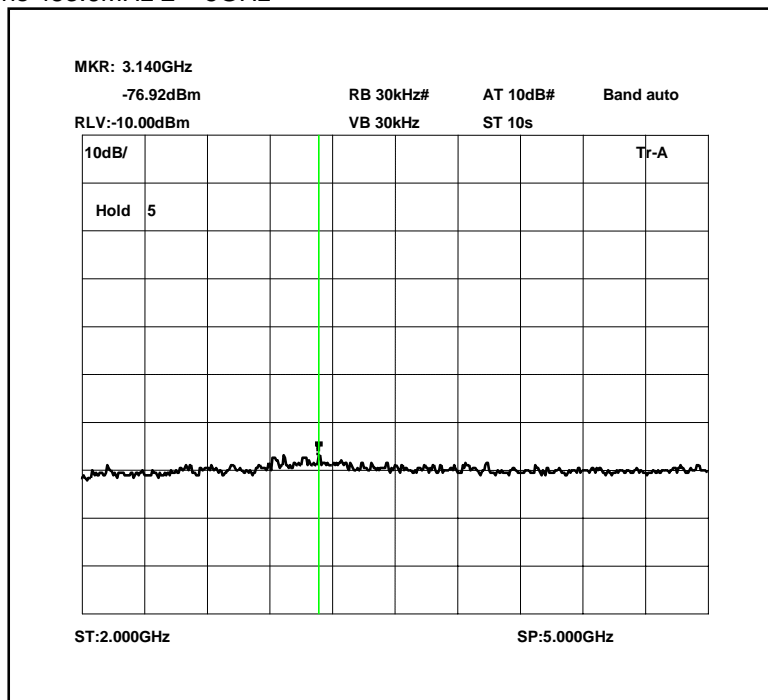

The above test results show that there were no emissions within 20dBs of the -13dBm limit.

Radiated emissions no input signal 0 -2GHz

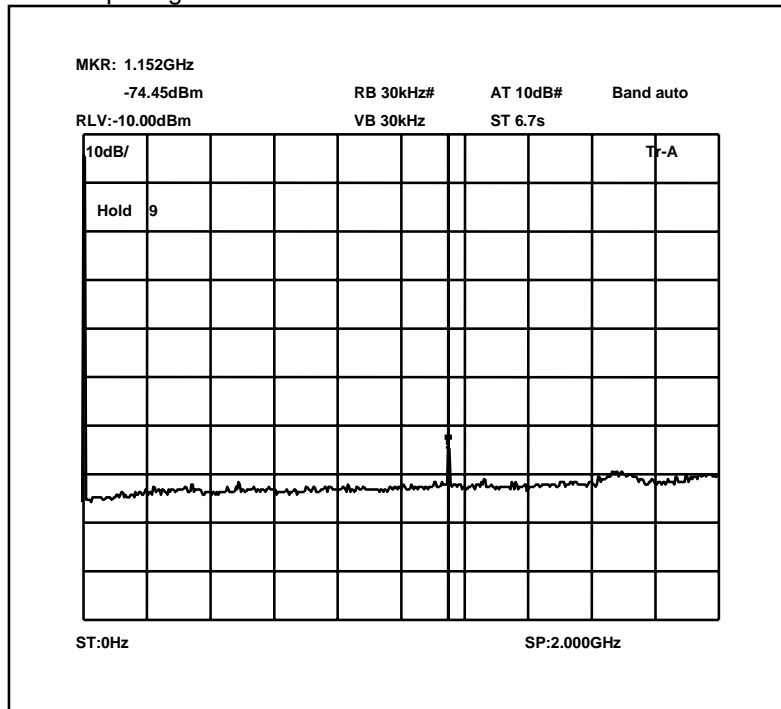

Radiated emissions no signal 2- 5 GHz

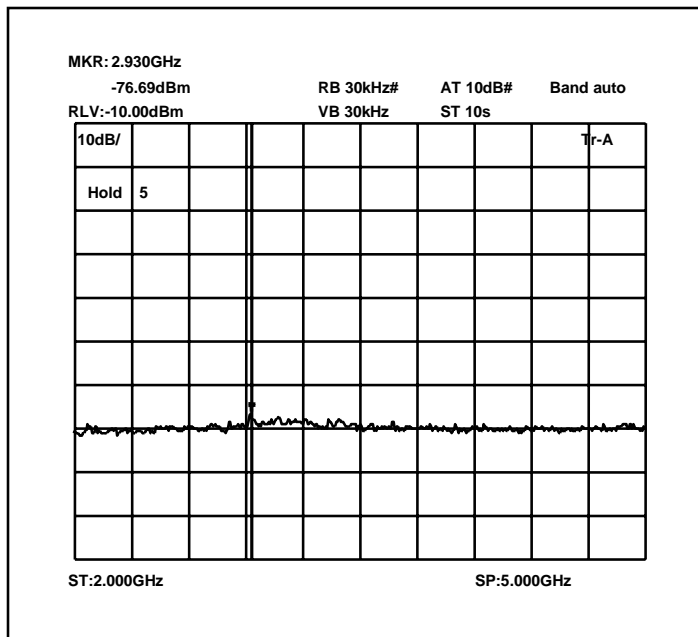

The above test results show that there were no emissions within 20dBs of the -13dBm limit.

TRANSMITTER TEST – GAIN – CONDUCTED – PART 2.1046 – UPLINK

Ambient temperature = 24°C
 Relative humidity = 53%
 Supply voltage = 110Vac
 Channel number = See test results

Radio Laboratory

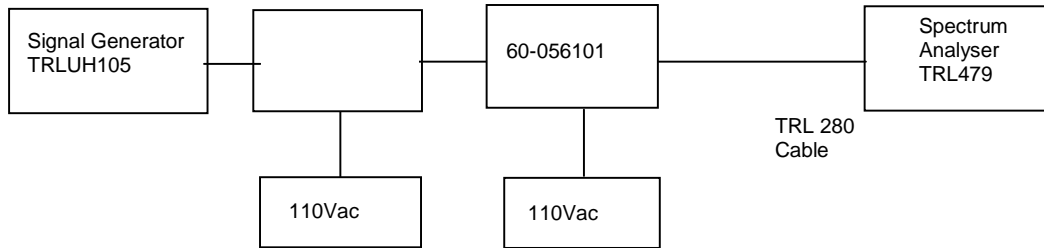

Frequency MHz	Signal Generator Input Level dBm	Cable Loss dB	Level at Spectrum Analyser dBm	Gain dB	Gain after 10dB increase input signal level dBm	Measured Output power dBm
473.2125	-74.0	0.3	-15.35	58.95	48.95	-15.05
473.2375	-74.0	0.3	-15.36	58.94	48.97	-15.06
473.2625	-74.0	0.3	-15.29	59.01	49.05	-14.99
485.2375	-63.0	0.3	-14.26	49.04	39.14	-13.96
485.9000	-64.0	0.3	-14.95	49.35	39.88	-14.65
486.5625	-62.0	0.3	-13.08	49.22	39.69	-12.78

The test was setup as above. The signal generator was to simulate an input signal to the system from a transmitter and the analyzer used to obtain the output level from the system.

TYPE OF EQUIPMENT	MAKER/SUPPLIER	MODEL No	SERIAL No	TRL No	ACTUAL EQUIPMENT USED
SPECTRUM ANALYSER	ANRITSU	MS266C	MT26089	479	X
ATTENUATOR	BIRD	8302	N/A	105	
ATTENUATOR	BIRD	8304-300-N	N/A	220	
CABLE	ROSENBERGER	MICRO COAX	N/A	280	X
SIGNAL GENERATOR	MARCONI	2023	112224/040	UH105	X

TRANSMITTER TEST - INTERMODULATION SPURIOUS EMISSIONS – CONDUCTED – PART 2.1053– UPLINK

Ambient temperature = 26°C
 Relative humidity = 41%
 Supply voltage = 110Vac

Radio Laboratory

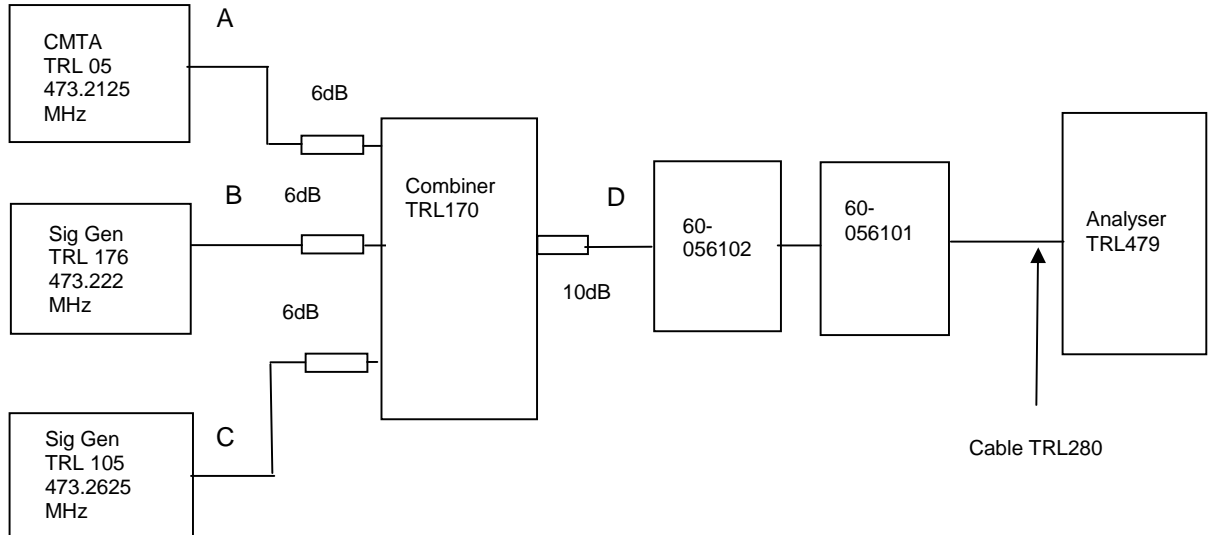

The intermodulation products test was performed as a system. The intermodulation and spurious products were measured with the fibre optic system operating at maximum input level. A three tone test was conducted using the equipment as above. The input power level was adjusted so the level at point D was the maximum input -62dBm.

Test result:
 Measured as compliant
 Sweep data is shown on the next page

Test equipment used for intermodulation test

TYPE OF EQUIPMENT	MAKER/SUPPLIER	MODEL No	SERIAL No	TRL No	ACTUAL EQUIPMENT USED
SPECTRUM ANALYSER	ANRITSU	MS2665C	MT26089	479	X
SIGNAL GENERATOR	MARCONI	2042	119562/02	254	X
CMTA	ROHDE & SCHWARZ	CMTA52	894715/033	05	X
SIGNAL GENERATOR	MARCONI	2023	112224/040	UH105	X
COMBINER	ELCOM	RC-4-50	N/A	170	x

Intermodulation Inband

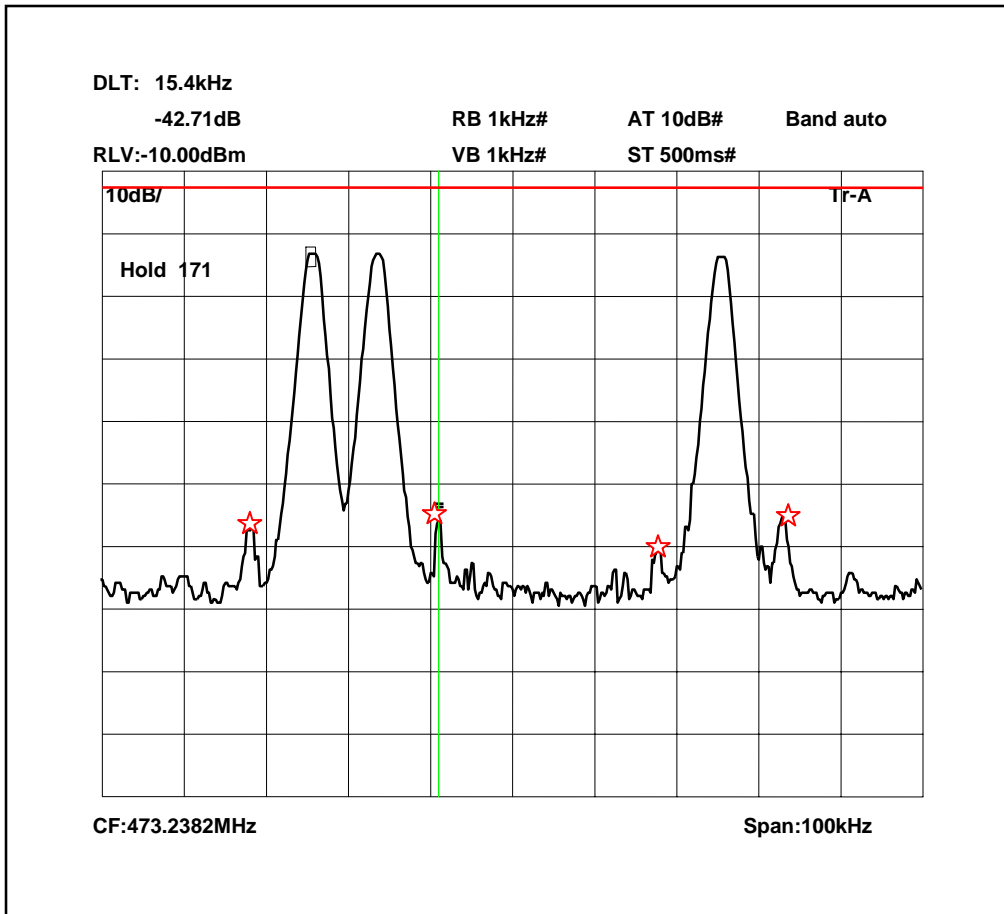

The above plot shows that all products (designated by ☆) are at least 40dB below the spurious limit. Based on -62dBm input to the system.

Intermodulation Wideband

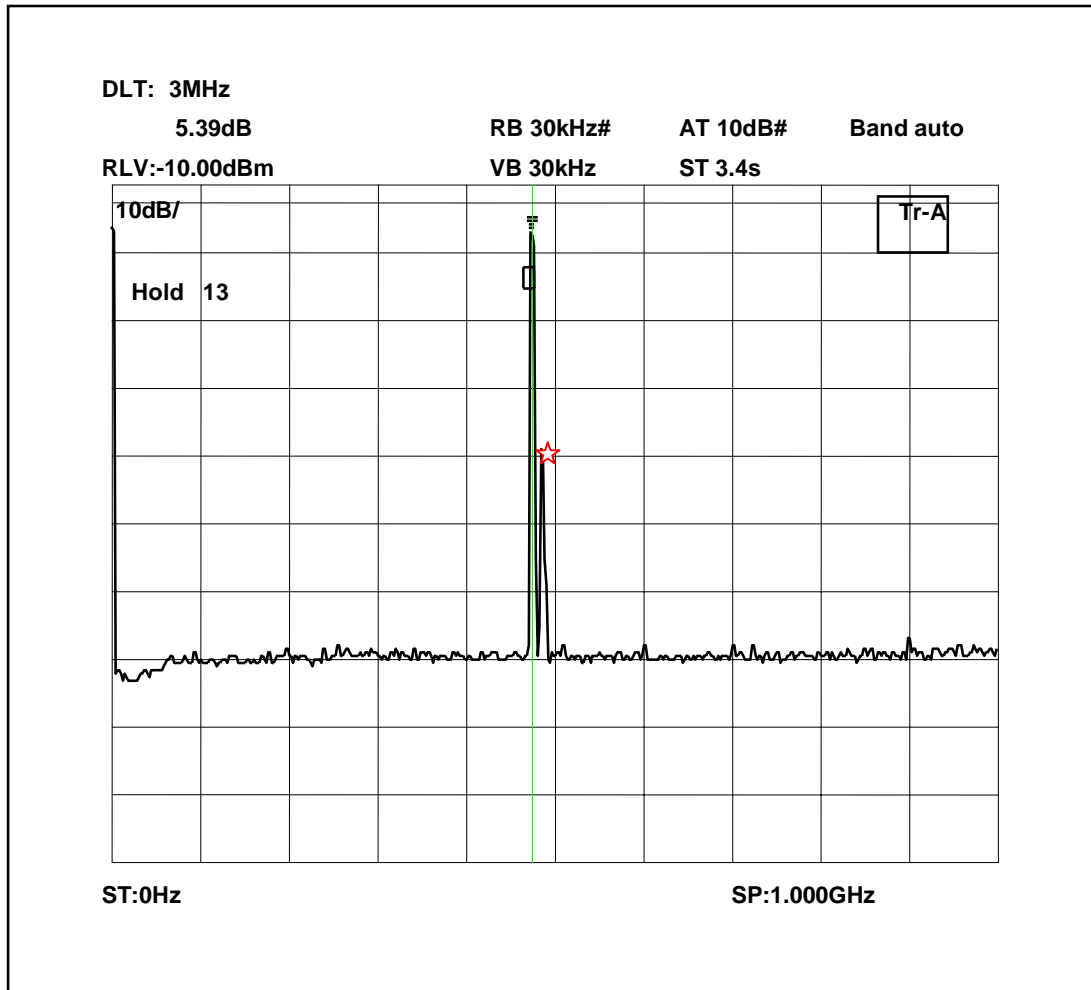

The above plot shows that all products (designated by ☆) are at least 30dB below the spurious limit.

Based on -62dBm input to the system

TRANSMITTER TEST - INTERMODULATION SPURIOUS EMISSIONS – CONDUCTED – PART 2.1053– UPLINK

Ambient temperature = 26°C
 Relative humidity = 41%
 Supply voltage = 110Vac

Radio Laboratory

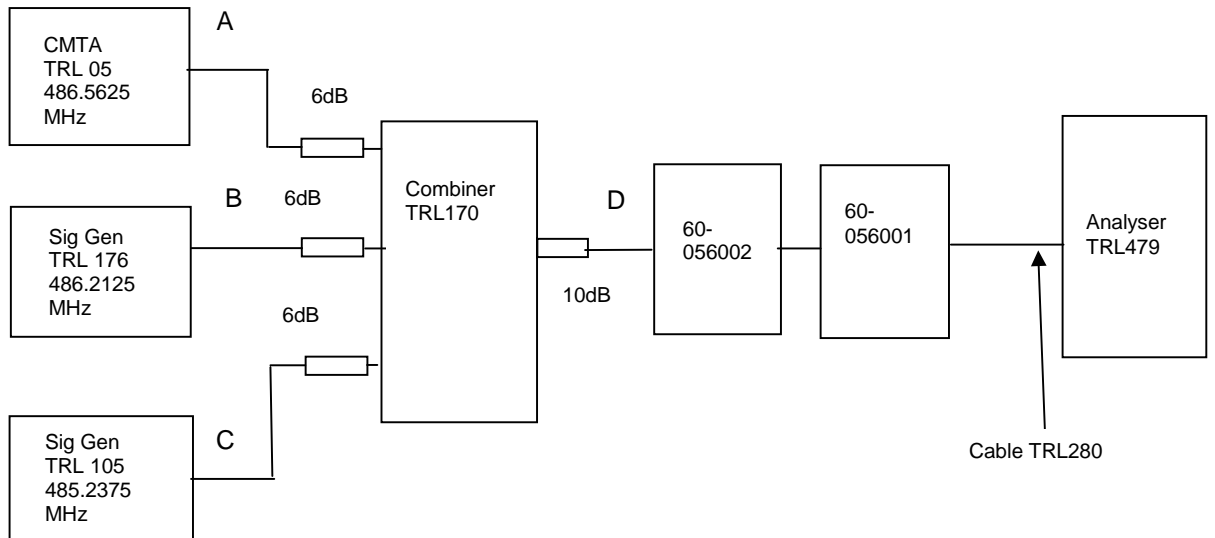

The intermodulation products test was performed as a system. The intermodulation and spurious products were measured with the fibre optic system operating at maximum input level. A three tone test was conducted using the equipment as above. The input power level was adjusted so the level at point D was the maximum input -51dBm.

Test result:
 Measured as compliant
 Sweep data is shown on the next page

Test equipment used for intermodulation test

TYPE OF EQUIPMENT	MAKER/SUPPLIER	MODEL No	SERIAL No	TRL No	ACTUAL EQUIPMENT USED
SPECTRUM ANALYSER	ANRITSU	MS2665C	MT26089	479	X
SIGNAL GENERATOR	MARCONI	2042	119562/02	254	X
CMTA	ROHDE & SCHWARZ	CMTA52	894715/033	05	X
SIGNAL GENERATOR	MARCONI	2023	112224/040	UH105	X
COMBINER	ELCOM	RC-4-50	N/A	170	x

Intermodulation Inband

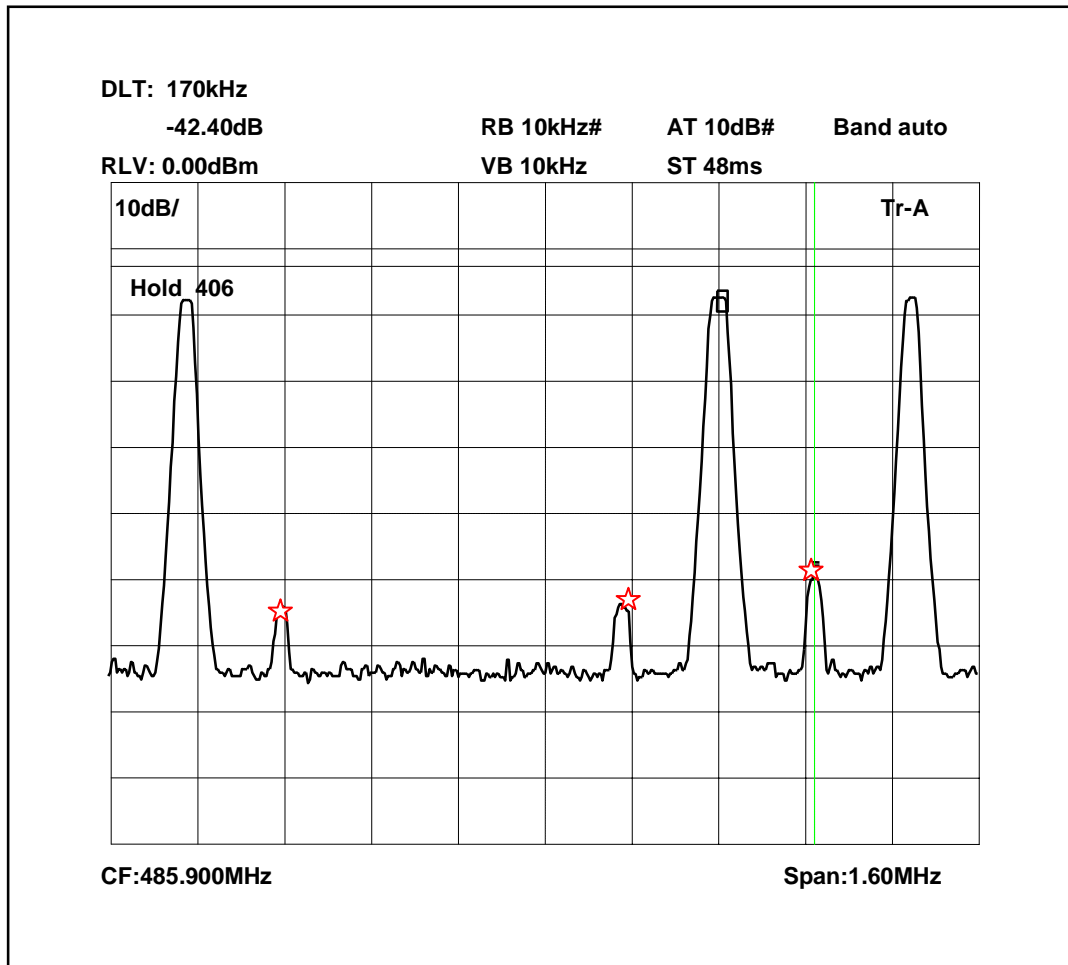

The above plot shows that all products (designated by ☆) are at least 40dB below the spurious limit.
Based on -51dBm input to the system.

Intermodulation Wideband

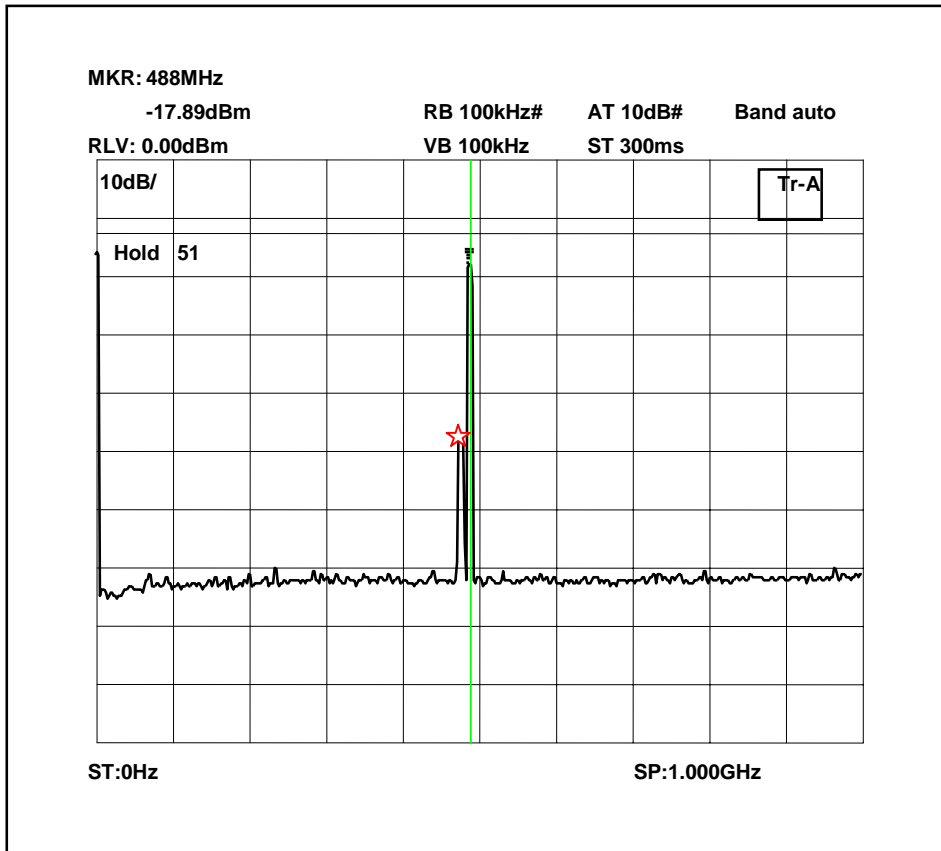

The above plot shows that all products (designated by☆) are at least 30dB below the spurious limit.

Based on -51dBm the input to the system.

TRANSMITTER TESTS

MODULATED BANDWIDTH TEST – CONDUCTED – Part 2.1049– UPLINK

Ambient temperature = 18°C
 Relative humidity = 40%
 Supply voltage = 110Vac
 Channel number = See test results

Radio Laboratory

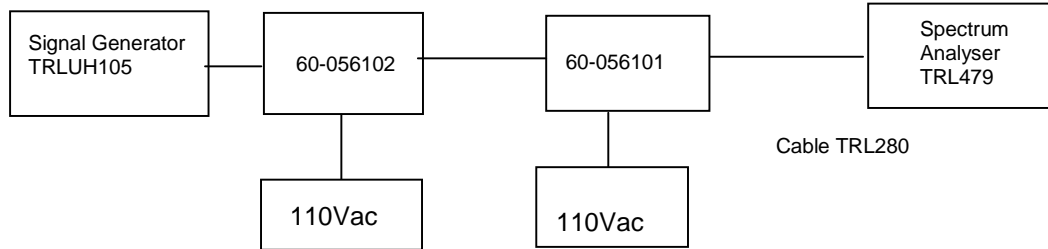

This test was performed to show that the fibre optic system does not alter the input signal in any way. The input signal was set to the maximum input level and modulated with a 2500Hz tone. The plots show the signal measured at the signal generator and the signal measured at the output of the EUT.
 Input level 470MHz -74dBm
 Input level 480Mhz -62dBm

Note: The cables and attenuators had the following losses.

1. Cable TRL280 between EUT and spectrum analyser= 0.3dB
2. Cable between signal generator and EUT = 0.22dB

TYPE OF EQUIPMENT	MAKER/SUPPLIER	MODEL No	SERIAL No	TRL No	ACTUAL EQUIPMENT USED
SPECTRUM ANALYSER	ANRITSU	MS2665C	MT26089	479	X
ATTENUATOR	BIRD	8304-200	N/A	105	X
ATTENUATOR	BIRD	8304-300-N	N/A	220	X
CABLE	ROSENBERGER	MICRO COAX	N/A	280	X
SIGNAL GENERATOR	MARCONI	2023	112224/040	UH105	X

473.2125MHz Signal Generator deviation set to 5kHz

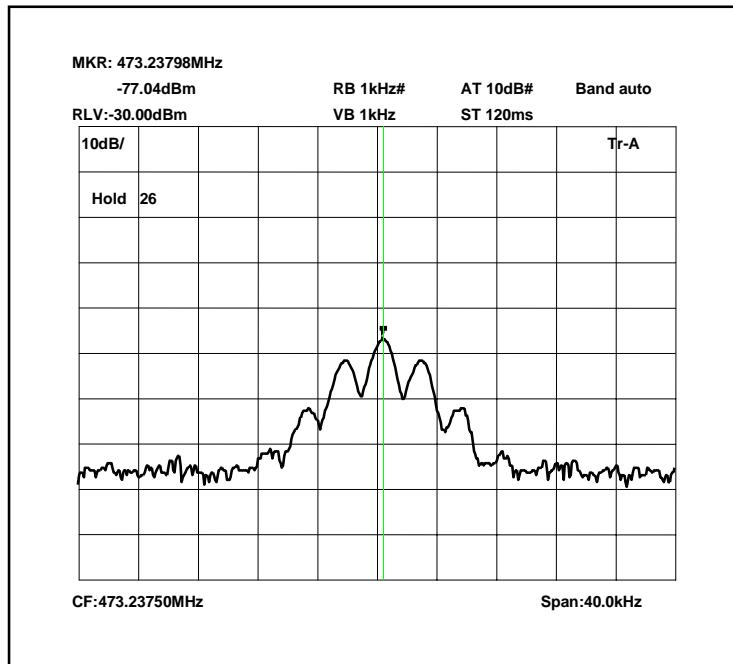

473.2125MHz Signal Generator and amplifier deviation set to 5kHz

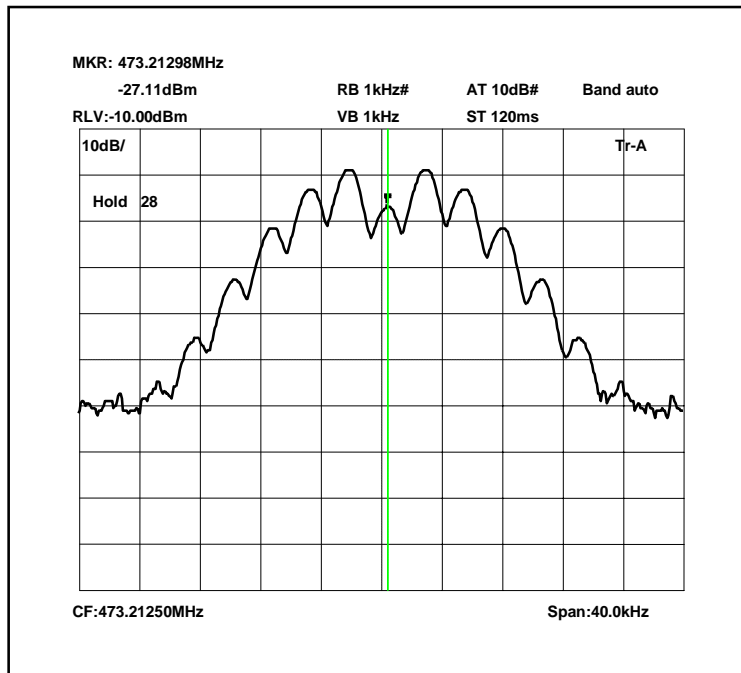

The above plots depicting the output waveshape show no measurable distortion visible when compared to the input signal.

473.2375MHz Signal Generator deviation set to 5kHz

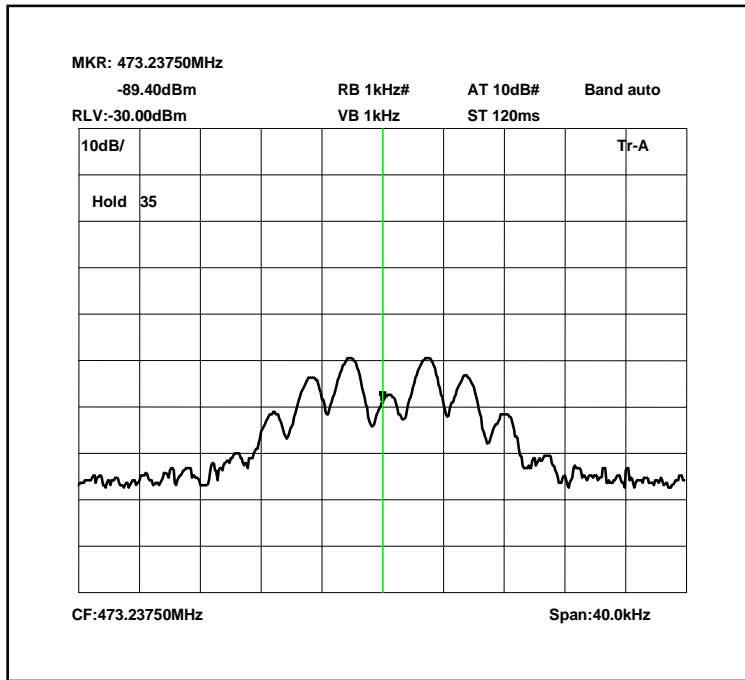

473.2375MHz Signal Generator and amplifier deviation set to 5kHz

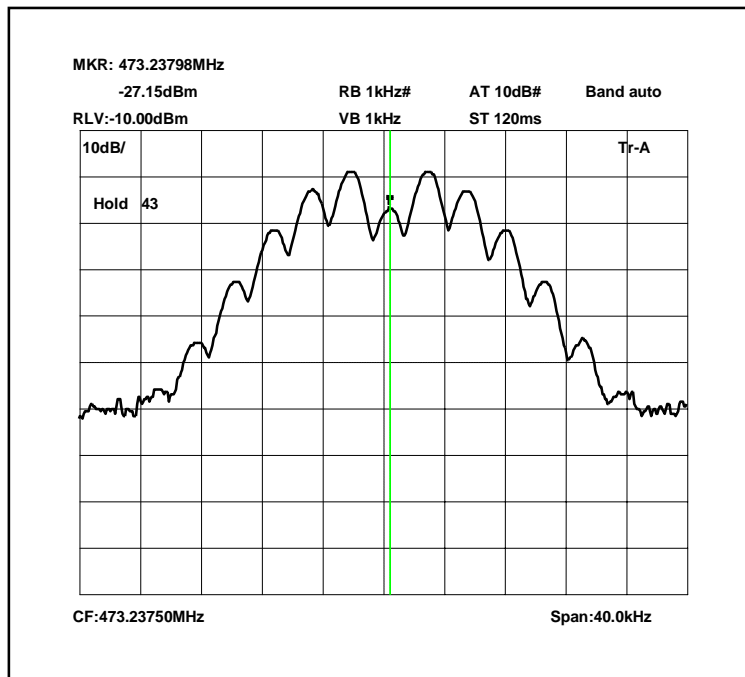

The above plots depicting the output wavsshape show no measurable distortion visible when compared to the input signal.

473.2625MHz Signal Generator deviation set to 5kHz

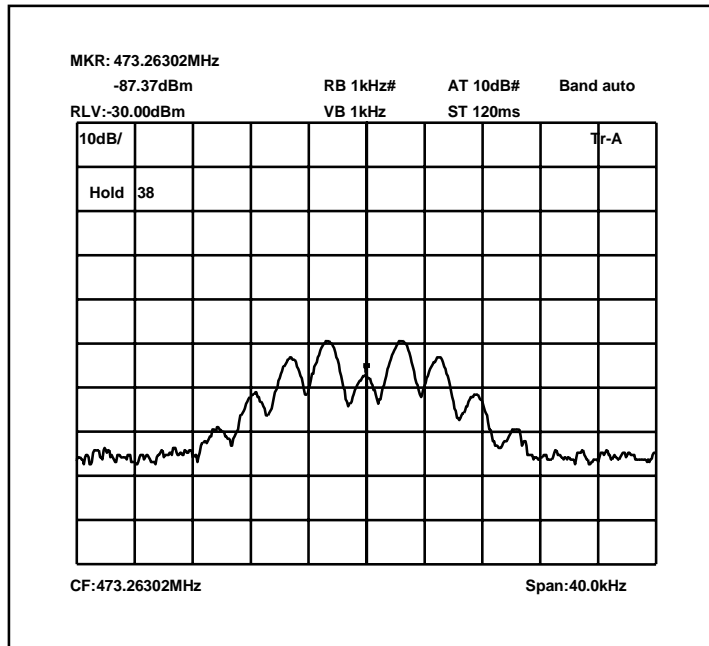

473.2625MHz Signal Generator and amplifier system deviation set to 5kHz

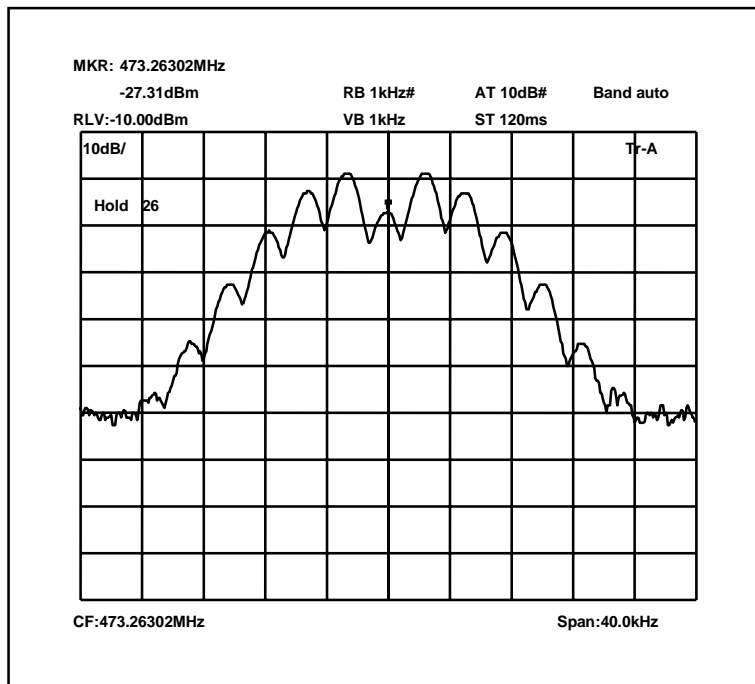

The above plots depicting the output waweshape show no measurable distortion visible when compared to the input signal.

485.2375MHz Signal Generator deviation set to 5kHz

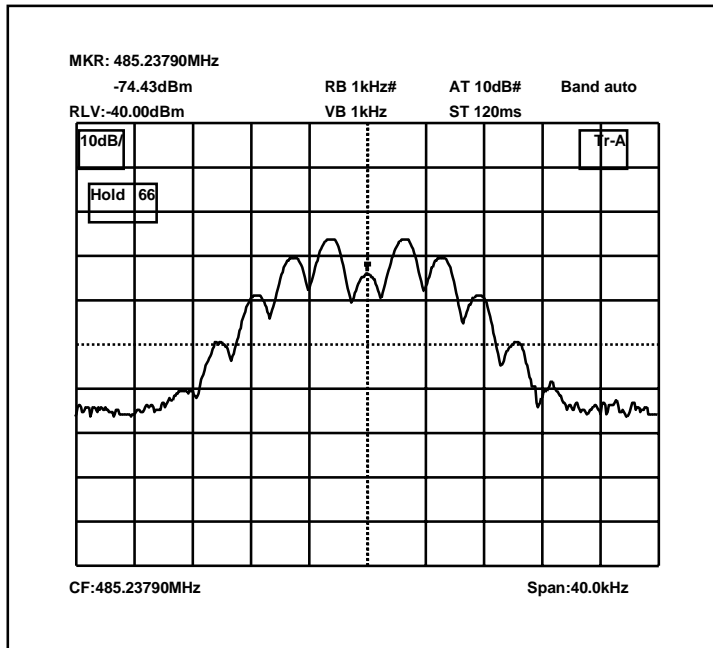

485.2375MHz Signal Generator and amplifier system deviation set to 5kHz

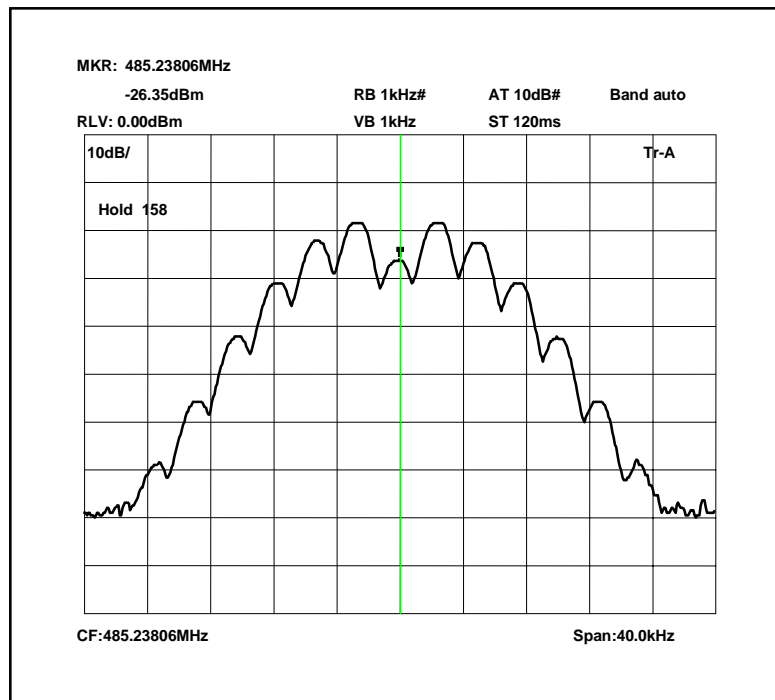

The above plots depicting the output waveshape show no measurable distortion visible when compared to the input signal.

485.900MHz Signal Generator deviation set to 5kHz

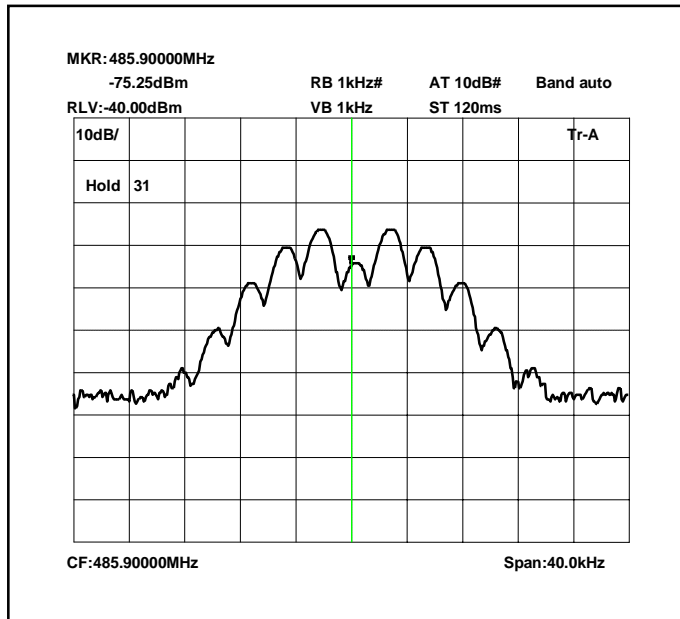

485.900MHz Signal Generator and amplifier system deviation set to 5kHz

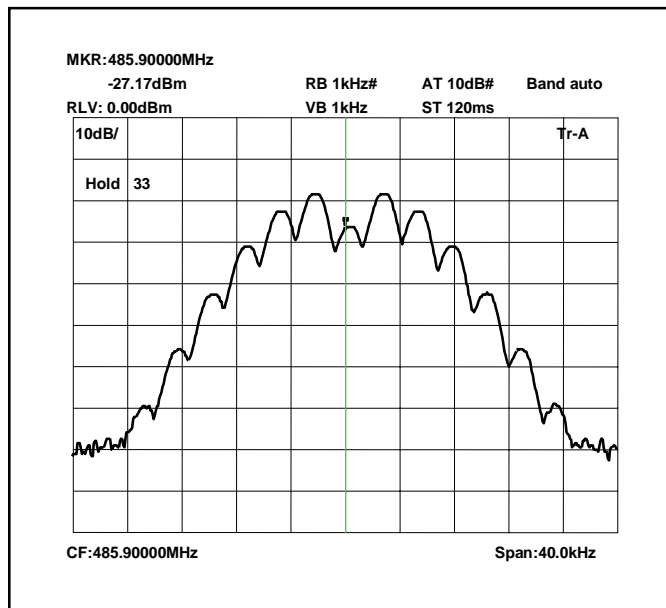

The above plots depicting the output waveshape show no measurable distortion visible when compared to the input signal.

486.5625MHz Signal Generator deviation set to 5kHz

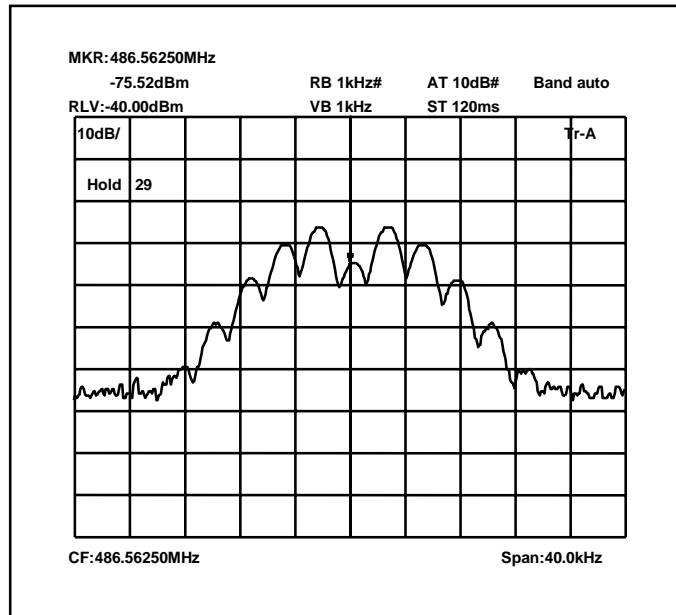

4865625MHz Signal Generator and amplifier system deviation set to 5kHz

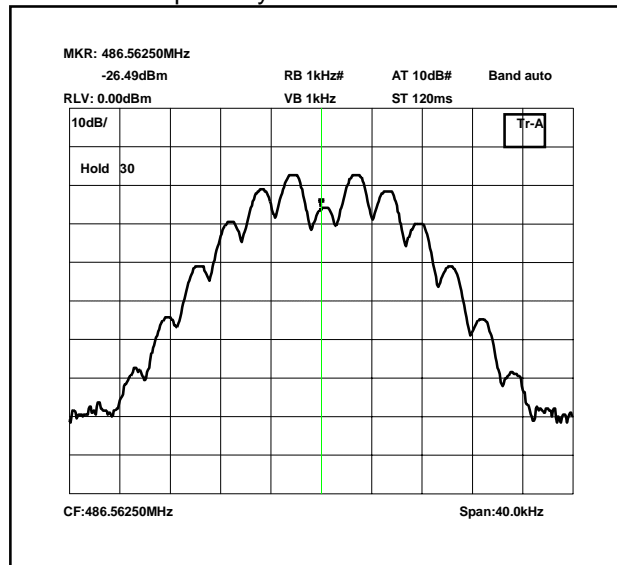

The above plots depicting the output waveshape show no measurable distortion visible when compared to the input signal.

TRANSMITTER TESTS

TRANSMITTER SPURIOUS EMISSIONS – CONDUCTED – Part 2.1053 – UPLINK

Ambient temperature = 18°C
 Relative humidity = 40%
 Supply voltage = 110Vac

Radio Laboratory Test Signal = F3E

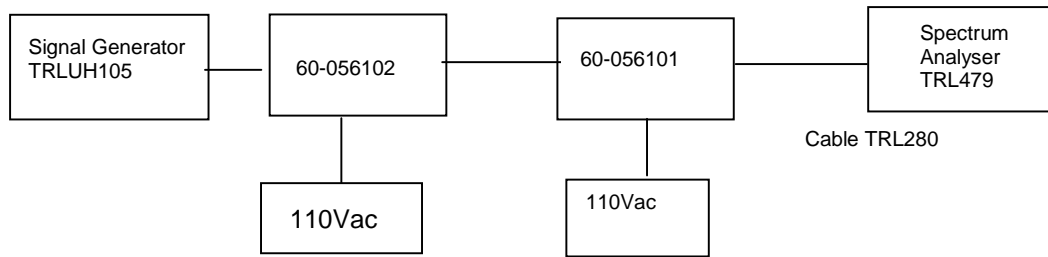

The test was set up as per the diagram. The level at the input was adjusted to compensate for the loss of the interconnecting cable. The unit was tested operating at maximum power and on three test frequencies.

The spurious limit was calculated as follows:

On any frequency removed from the assigned frequency by more than 250% of the authorised bandwidth

At least 43 + 10 log PdB

$$(10\log P_{\text{watts}}) - (43 + 10\log (P_{\text{watts}} * 1000)) = \text{LIMIT} = -13 \text{ dBm}$$

Results

No significant emissions were detected within 20dBm of limit.

The test equipment used for the Transmitter Conducted Emissions:

TYPE OF EQUIPMENT	MAKER/SUPPLIER	MODEL No	SERIAL No	TRL No	ACTUAL EQUIPMENT USED
SPECTRUM ANALYSER	ANRITSU	MS2665C	MT26089	479	X
ATTENUATOR	BIRD	8304-200	N/A	105	
ATTENUATOR	BIRD	8304-300-N	N/A	220	
CABLE	ROSENBERGER	MICRO COAX	N/A	280	X
SIGNAL GENERATOR	MARCONI	2023	112224/040	UH105	X

Conducted emissions 473.2115MHz 0 – 2 GHz

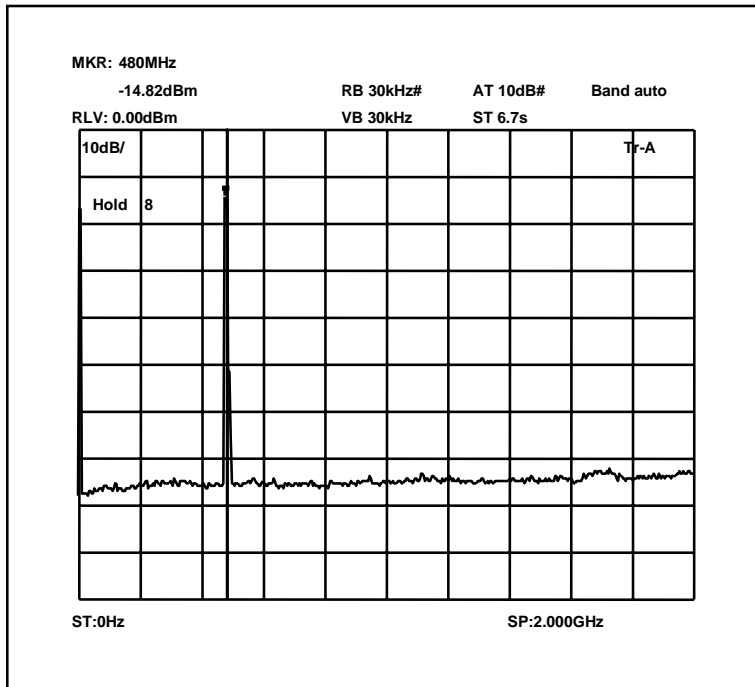

Conducted emissions 473.2115MHz 2 – 5 GHz

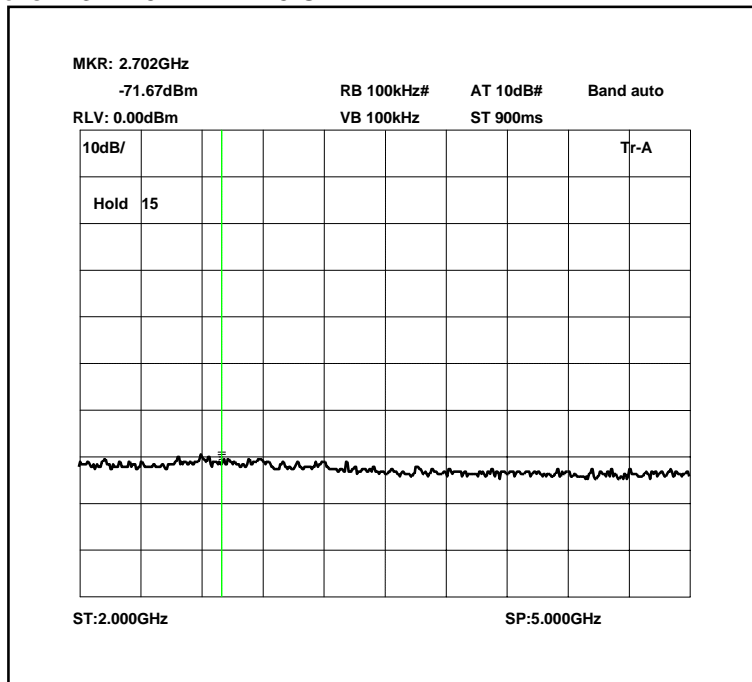

Conducted emissions 473.2375MHz 0 – 2.0 GHz

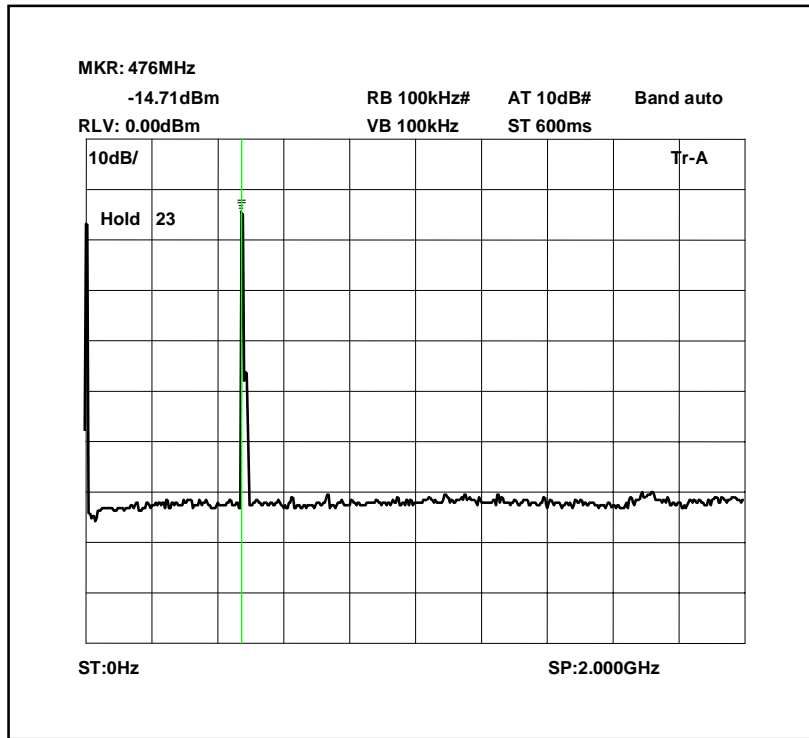

Conducted emissions 473.2375MHz 2.0 – 5.0 GHz

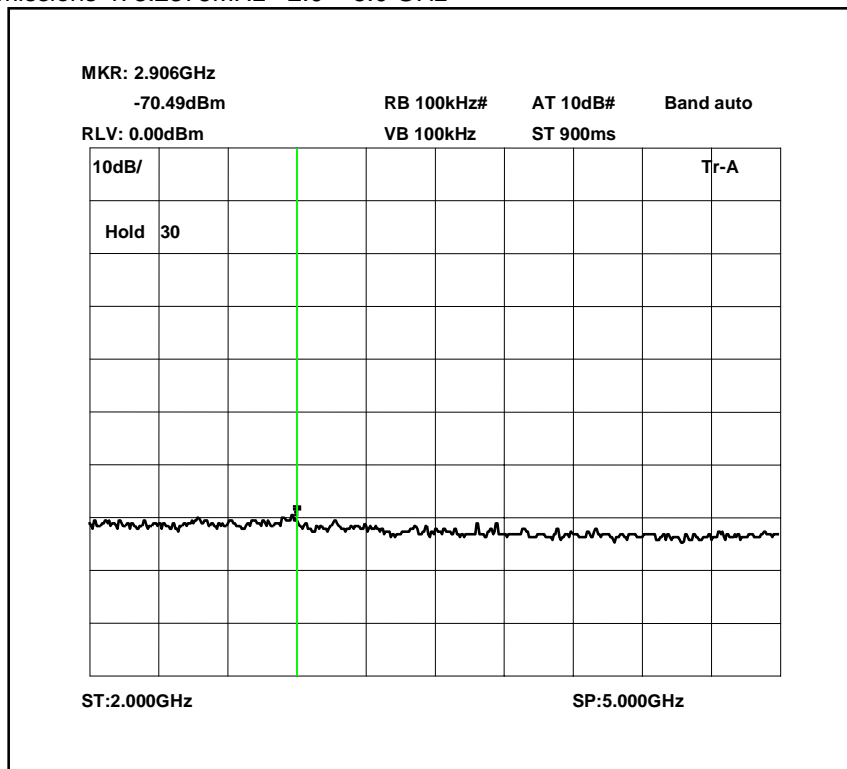

Conducted emissions 473.2625MHz 0 – 2 GHz

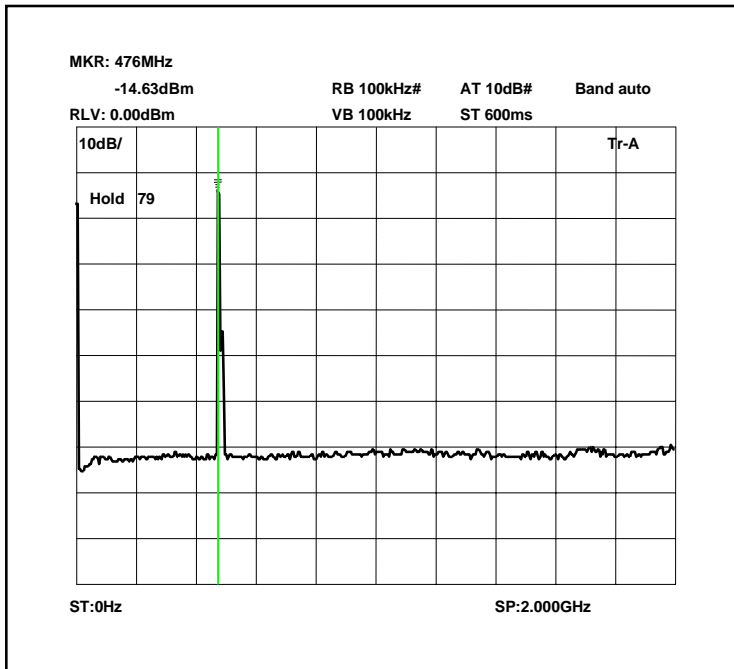

Conducted emissions 473.2625MHz 2 – 5 GHz

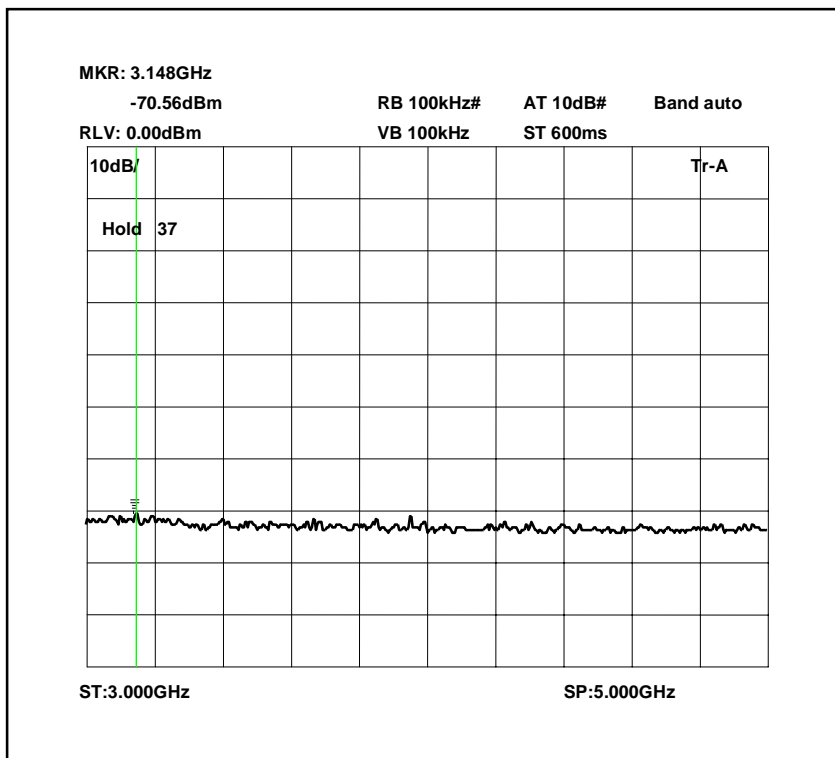

Conducted emissions 485.2375MHz 0 – 2 GHz

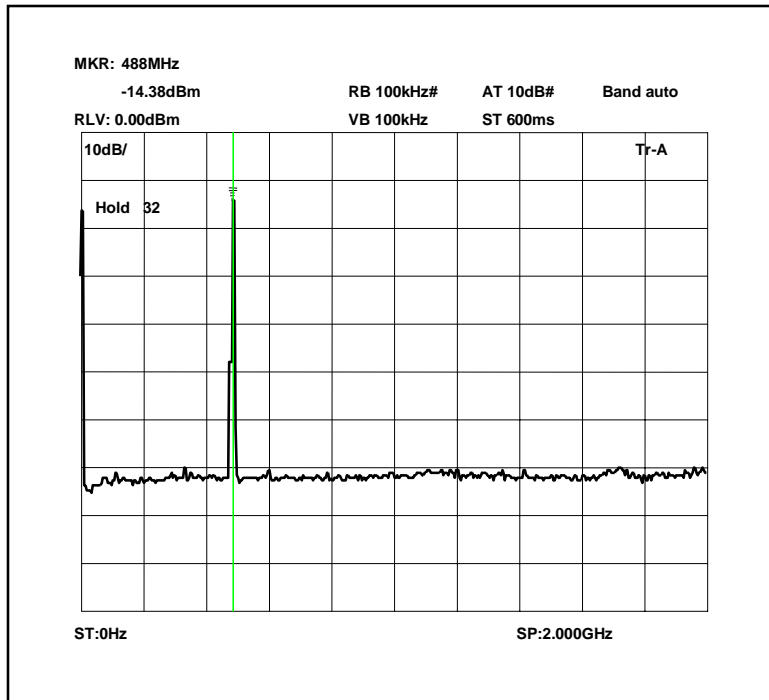

Conducted emissions 485.2375MHz 2 – 5 GHz

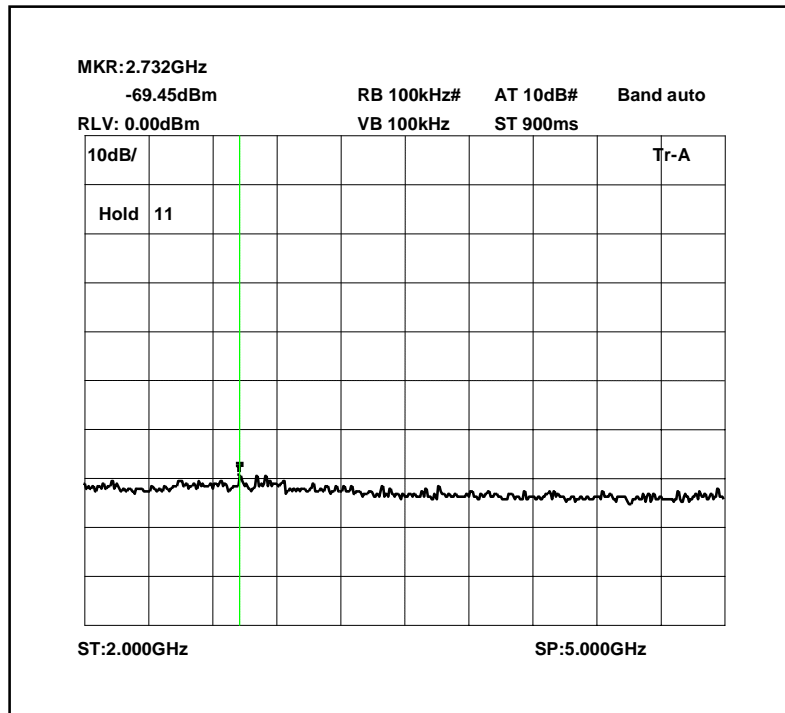

Conducted emissions 485.900MHz 0 – 2 GHz

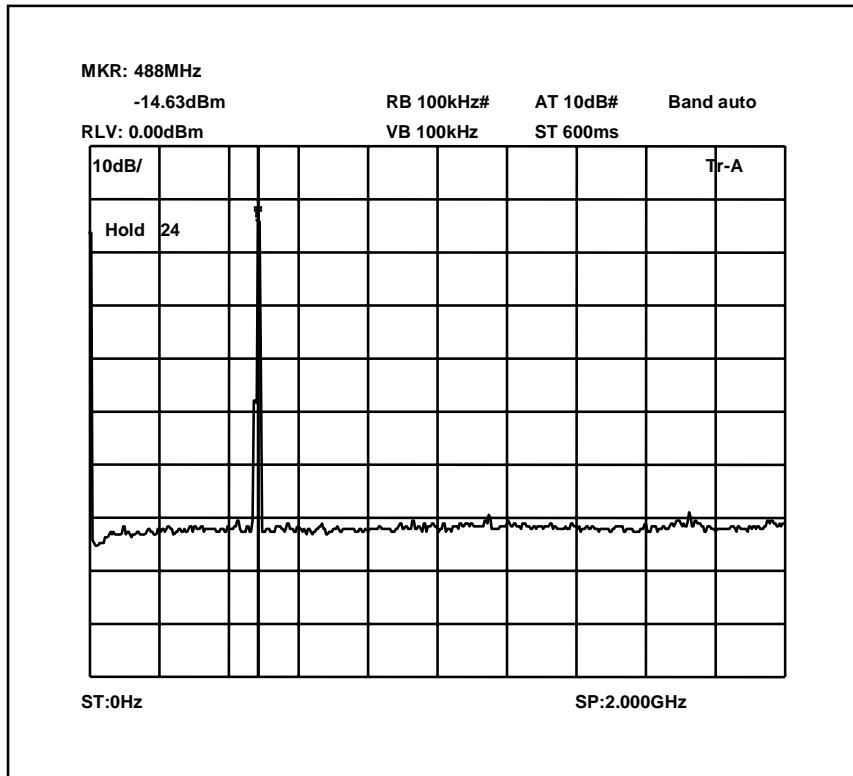

Conducted emissions 485.900MHz 2 – 5 GHz

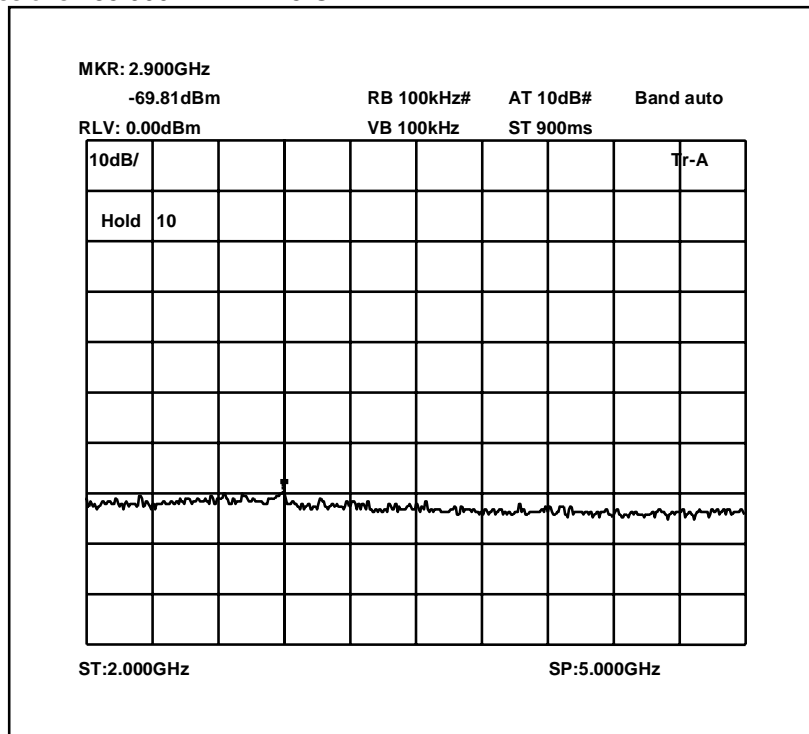

Conducted emissions 486.5625MHz 0 – 2 GHz

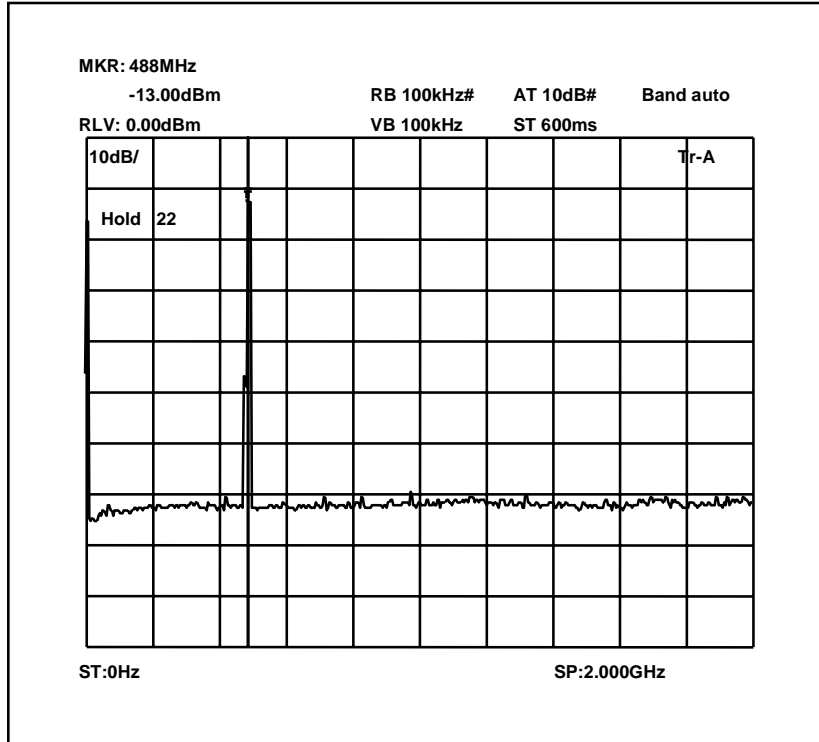

Conducted emissions 486.5625MHz 2 - 5 GHz

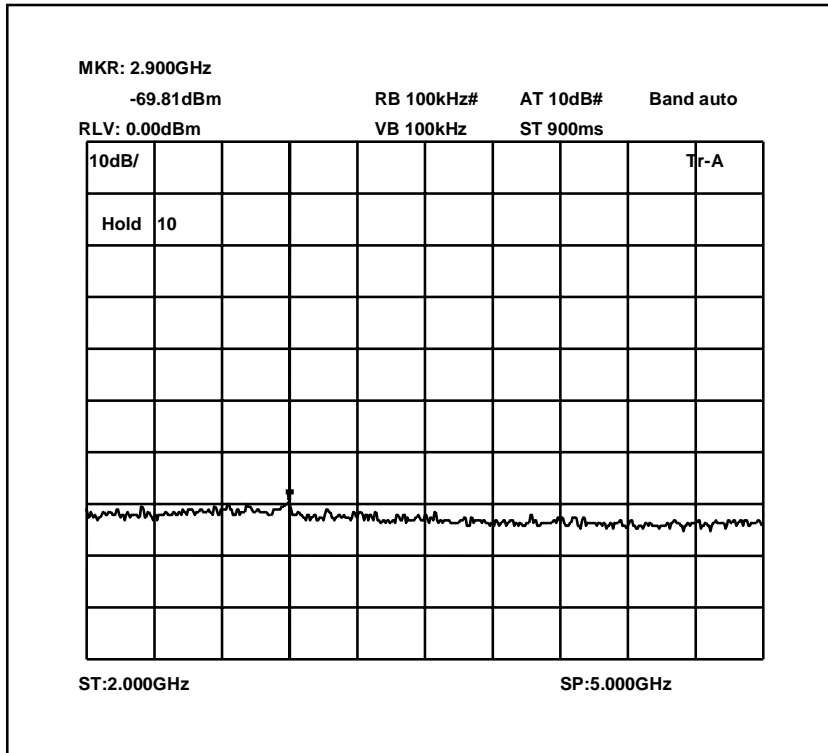

TRANSMITTER TESTS

TRANSMITTER SPURIOUS EMISSIONS – RADIATED – Part 2.1053– UPLINK

Ambient temperature = 21°C
 Relative humidity = 50%
 Conditions = OATS
 Supply voltage = 110Vac
 Supply Frequency = N/A

Test Signal = F3E

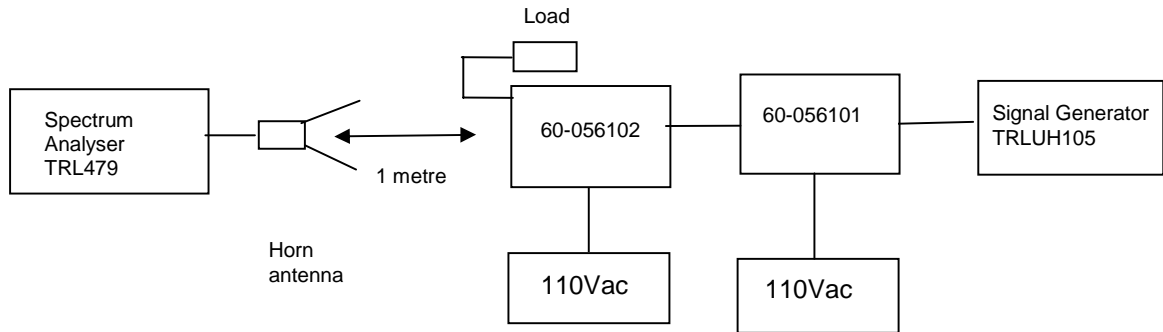

The test was set up as per the diagram. The level at the input was adjusted to compensate for the loss of the interconnecting cable. The unit was tested operating maximum power on three test frequencies with a 50 ohm load on the output. The unit was also tested with the signal generator replaced by another 50ohm load.

The Spurious limit was calculated as follows:

On any frequency removed from the assigned frequency by more that 250% of the authorised bandwidth

At least 43 + 10 log PdB

$$(10\log P_{\text{watts}}) - (43+10\log (P_{\text{watts}} * 1000)) = \text{LIMIT} = -13 \text{ dBm}$$

Test result

No significant emissions with 20dBm of limit.

The test equipment used for the Transmitter Spurious Emissions:

TYPE OF EQUIPMENT	MAKER/SUPPLIER	MODEL No	SERIAL No	TRL No	ACTUAL EQUIPMENT USED
SPECTRUM ANALYSER	ANRITSU	MS2665C	MT26089	479	X
HORN	EMCO	3115	9010-3581	139	X
ATTENUATOR	BIRD	8304-300-N	N/A	220	X
ATTENUATOR	BIRD	8308-100	N/A	112	X
CABLE	ROSENBERGER	MICRO COAX	N/A	280	X
SIGNAL GENERATOR	MARCONI	2023	112224/040	UH105	X

Radiated emissions 473.2125MHz 0 – 2GHz

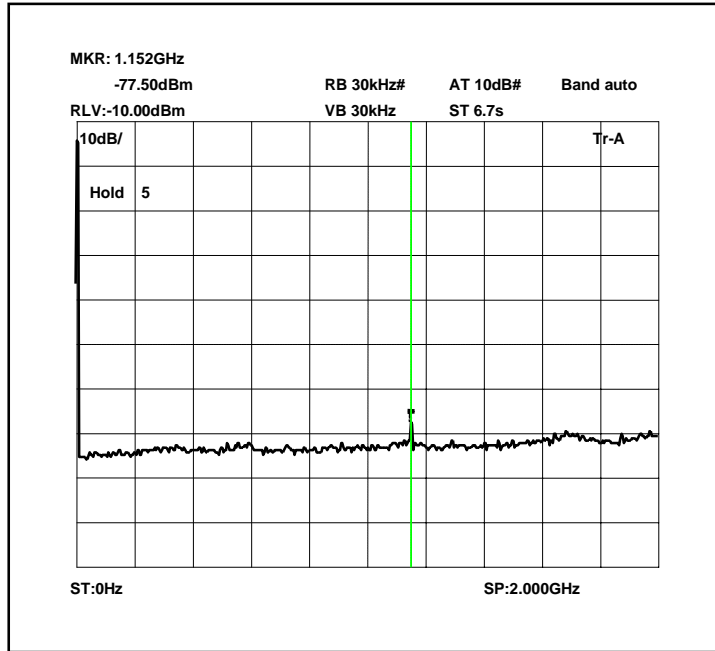

Radiated emissions 473.2125MHz 2-5GHz

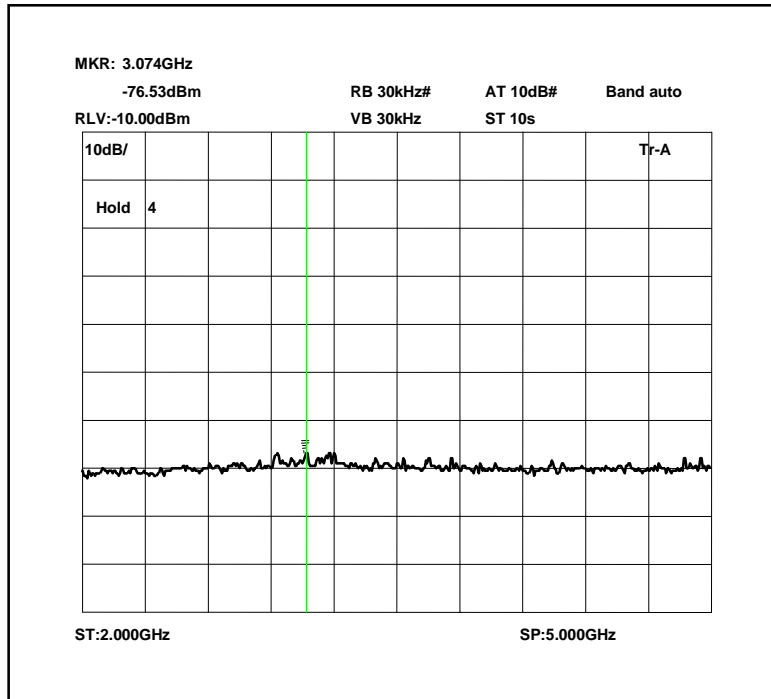

The above test results show that there were no emissions within 20dBs of the -13dBm limit.

Radiated emissions 473.2MHz 0 -2GHz

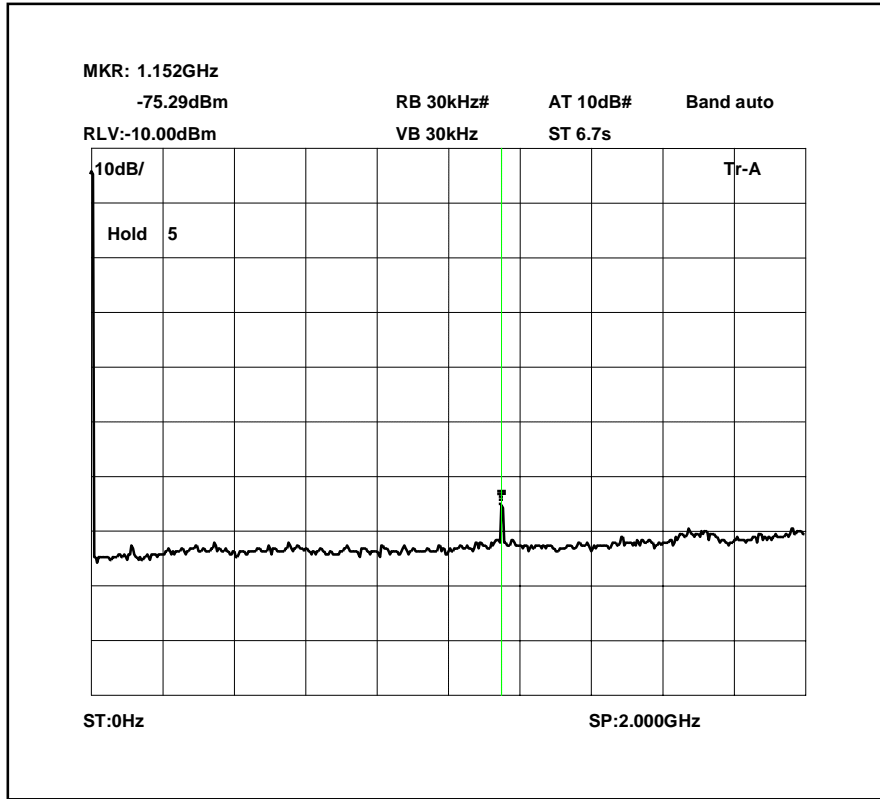

Radiated emissions 473.2MHz 2-5 GHz

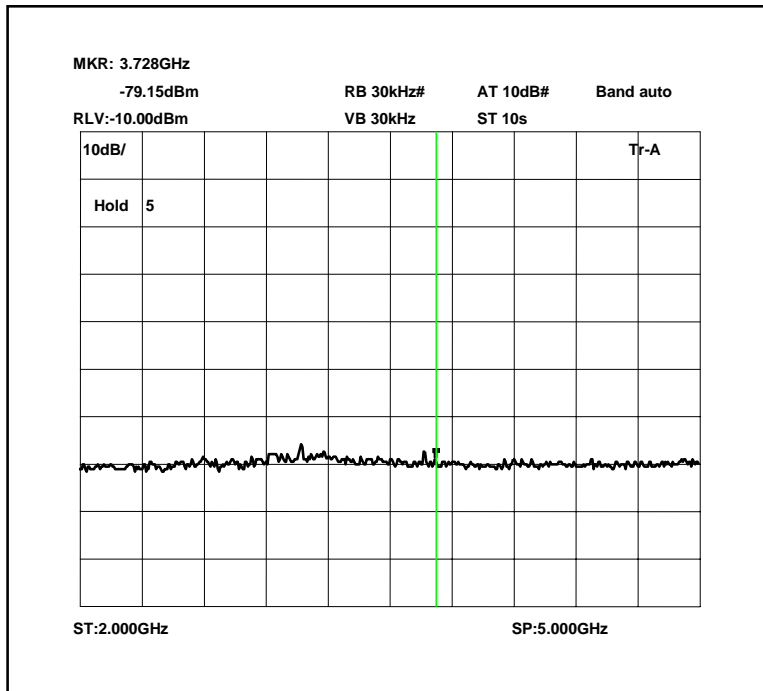

The above test results show that there were no emissions within 20dBs of the -13dBm limit.

Radiated emissions 473.2525MHz 0 -2 GHz

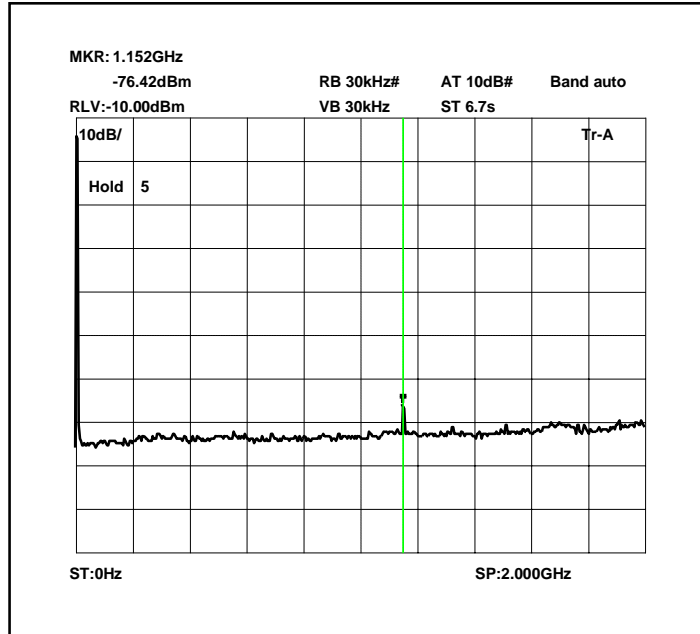

Radiated emissions 473.2525MHz 2 – 5GHz

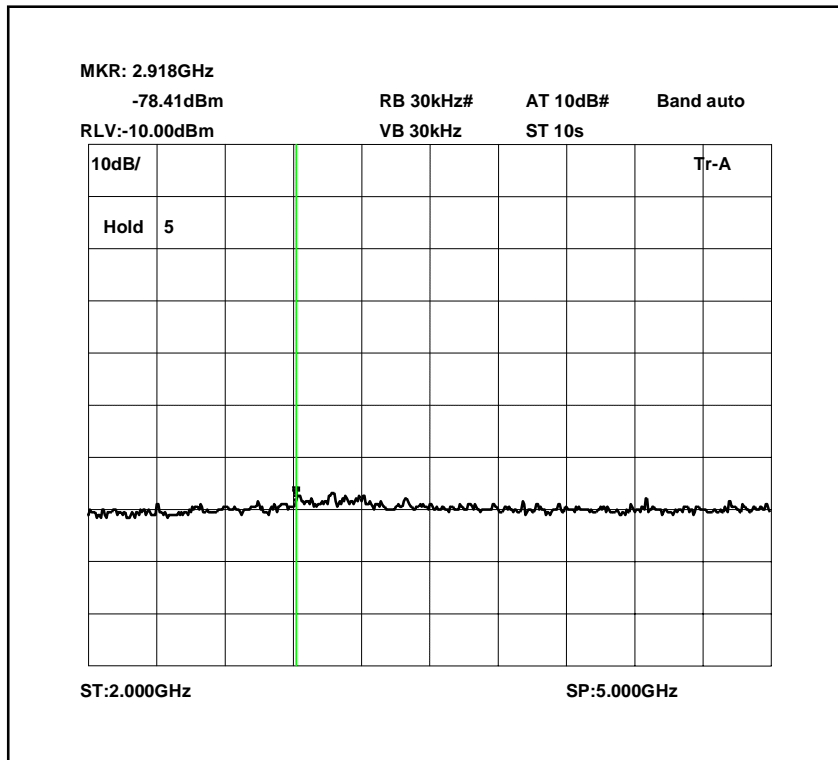

The above test results show that there were no emissions within 20dBs of the -13dBm limit.

Radiated emissions 485.2375MHz 0 -2 GHz

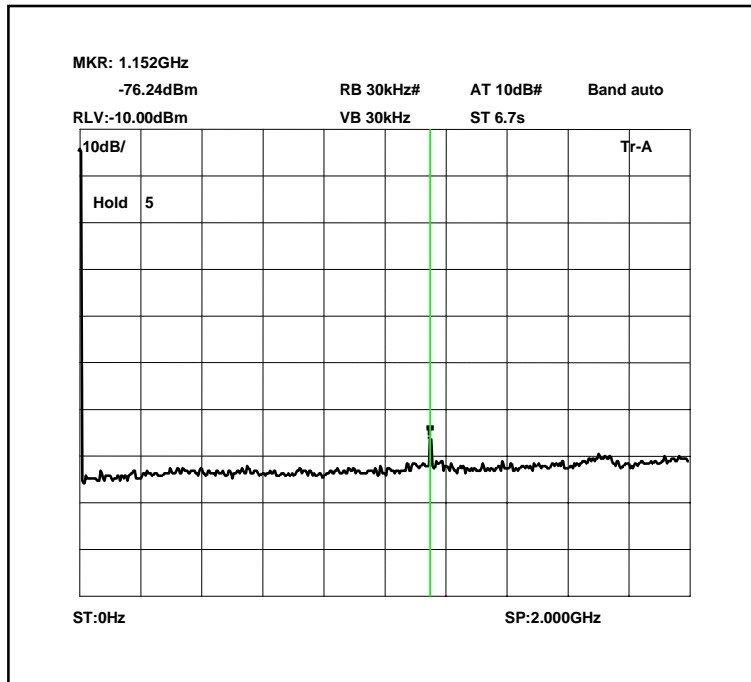

Radiated emissions 485.2375MHz 2 – 5GHz

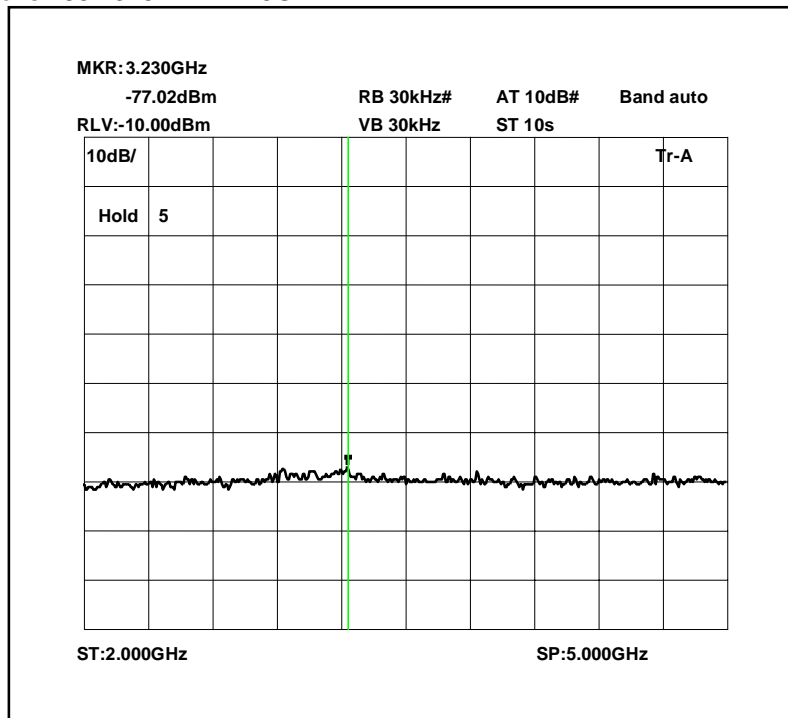

The above test results show that there were no emissions within 20dBs of the -13dBm limit.

Radiated emissions 485.9MHz 0 -2 GHz

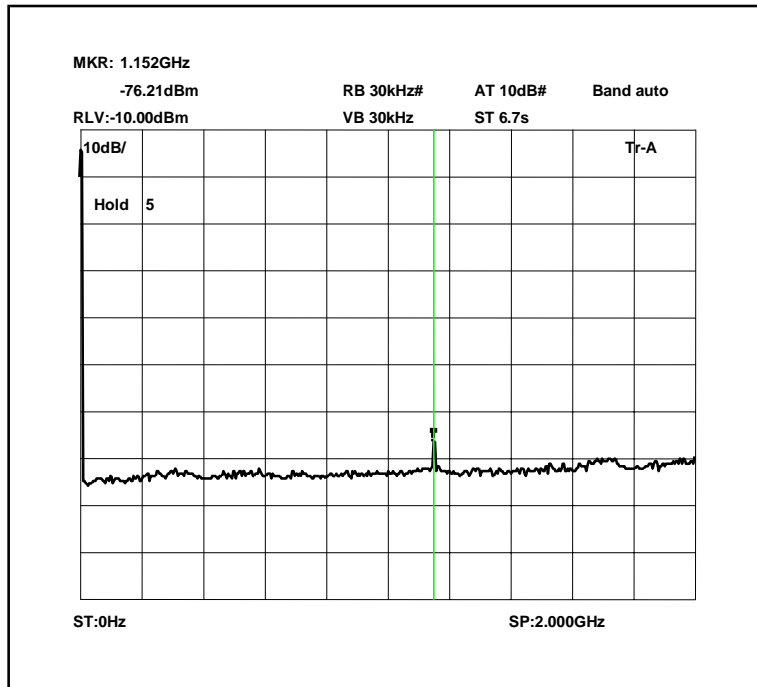

Radiated emissions 485.9MHz 2 – 5GHz

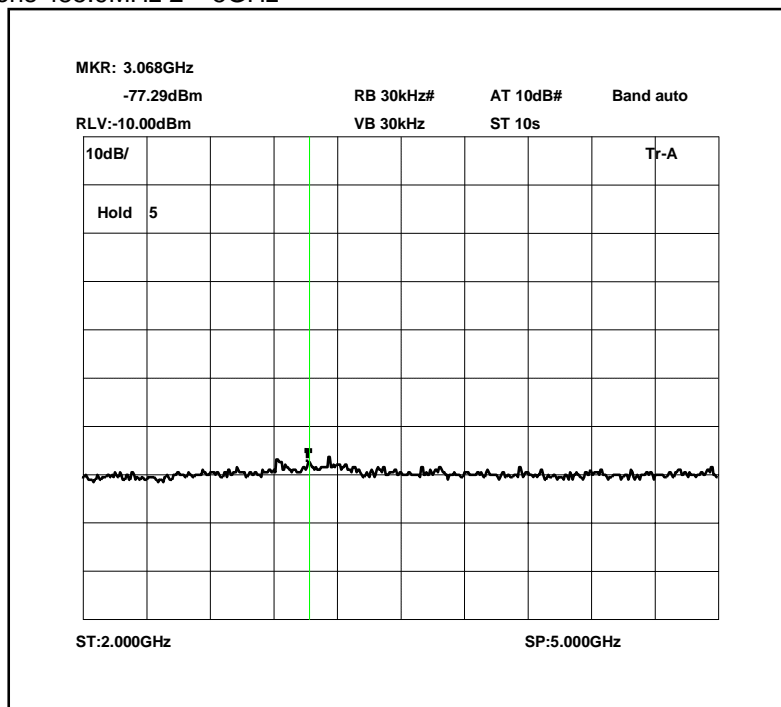

The above test results show that there were no emissions within 20dBs of the -13dBm limit.

Radiated emissions no input signal 0 -2GHz

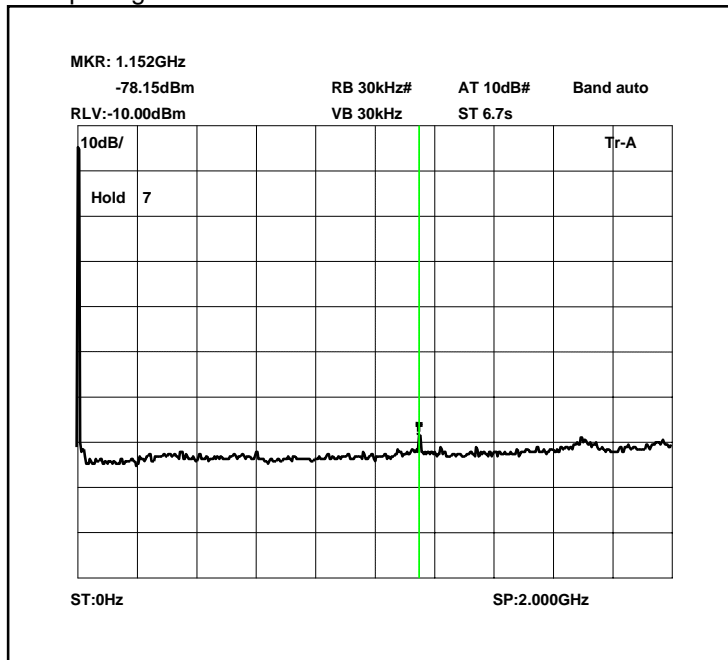

Radiated emissions no signal 2- 5 GHz

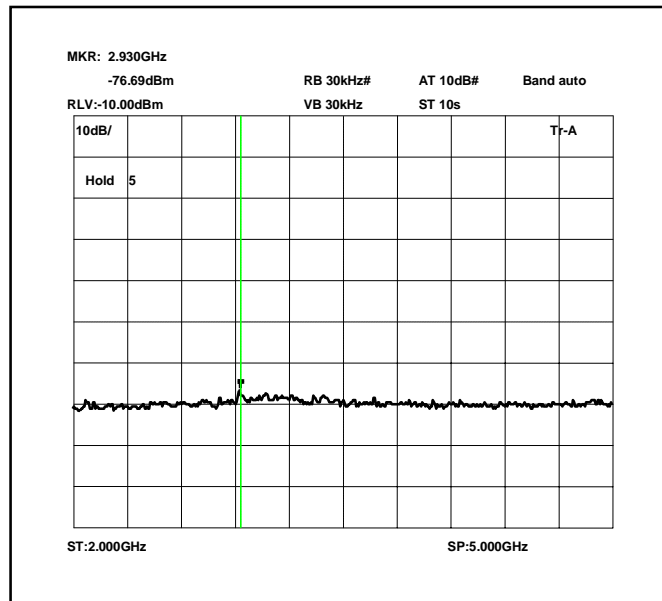

The above test results show that there were no emissions within 20dBs of the -13dBm limit.

ANNEX A
PHOTOGRAPHS

PHOTOGRAPH No. 1

TEST SETUP



PHOTOGRAPH No. 2

TEST SETUP

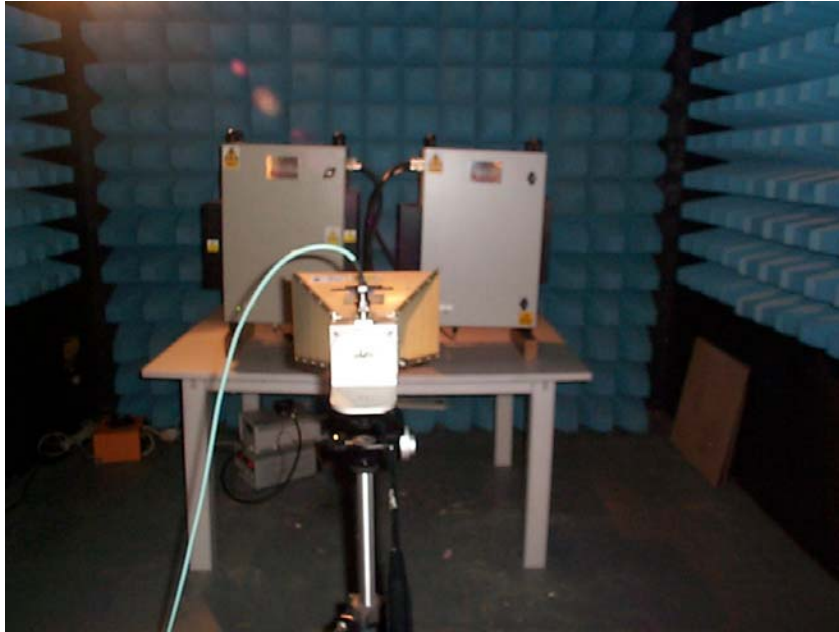

ANNEX B
TEST EQUIPMENT CALIBRATION DETAILS

TEST EQUIPMENT CALIBRATION DETAILS

TRL Number	Equipment Type	Manufacturer	Last Cal Calibration	Calibration Period
	3m Range ERP			
UH006	CAL	TRL	01/03/05	12
UH028	Log Periodic Ant	Schwarbeck	28/04/05	24
UH029	Bicone Antenna	Schwarbeck	27/04/05	24
UH041	Multimeter	AVOmeter	14/12/04	12
UH120	Spectrum Analyser	Marconi	15/03/05	12
UH122	Oscilloscope	Tektronix	07/06/05	24
UH162	ERP Cable Cal	TRL	23/05/05	12
UH179	Power Sensor	Marconi	14/12/04	12
UH228	Power Sensor	Marconi	17/01/05	12
UH253	1m Cable N type	TRL	10/01/05	12
UH254	1m Cable N type	TRL	10/01/05	12
L005	CMTA	R&S	22/10/04	12
L007	Loop Antenna	R&S	29/03/05	24
L138	1-18GHz Horn	EMCO	15/04/05	24
L139	1-18GHz Horn	EMCO	03/05/05	24
L176	Signal Generator	Marconi	31/01/05	12
L193	Bicone Antenna	Chase	12/10/03	24
L203	Log Periodic Ant	Chase	21/10/03	24
L254	Signal Generator	Marconi	13/12/04	12
L280	18GHz Cable	Rosenberger	10/01/05	12
L343	CCIR Noise Filter	TRL	07/06/05	12
	Temperature			
L426	Indicator	Fluke	14/12/04	12
L478	Signal Generator	R&S	19/05/04	12
L479	Analyser	Anritsu	05/10/04	12
L552	Signal Generator	Agilent	25/04/05	12

**ANNEX C
SYSTEM DIAGRAM**

