



TEST REPORT NO: RU1201/6636
COPY NO: .2.....
ISSUE NO: 1
FCC ID: NEOCCE-480N4

**ADDITIONAL REPORT ON THE CERTIFICATION TESTING OF
AERIAL FACILITIES LIMITED
60-055902
UPLINK ONLY
WITH RESPECT TO
THE FCC RULES CFR 47, PART 90 SUBPART I
WIDEBAND INTERMODULATION**

TEST DATE: 8th November 2005

TESTED BY: J CHARTERS
APPROVED BY: P GREEN
PRODUCT MANAGER
EMC
DATE: 9th November 2005.....

Distribution:

- Copy Nos:
1. Aerial Facilities Limited
 2. TCB: CKC Certification Services
 3. TRL EMC

THIS DOCUMENT MAY BE REPRODUCED ONLY IN ITS ENTIRETY AND WITHOUT CHANGE



CONTENTS

	PAGE
CERTIFICATE OF CONFORMITY & COMPLIANCE	3
APPLICANT'S SUMMARY	4
EQUIPMENT TEST CONDITIONS	5
TESTS REQUIRED	5
TEST RESULTS	6-12
ANNEX	
TEST EQUIPMENT CALIBRATION DETAILS	A

Notes:

- | | | | |
|----|---|-----|-----|
| 1. | Component failure during test | YES | [] |
| | | NO | [X] |
| 2. | If Yes, details of failure: | | |
| 3. | The facilities used for the testing of the product contain in this report are FCC Listed. | | |



CERTIFICATE OF CONFORMITY & COMPLIANCE

FCC IDENTITY:	NEOCCE-480N4
PURPOSE OF TEST:	Certification
TEST SPECIFICATION:	FCC RULES CFR 47, PART 90 SUBPART I Wideband intermodulation
TEST RESULT:	Compliant to Specification
EQUIPMENT UNDER TEST:	60-055902 (UPLINK only)
EQUIPMENT TYPE:	Booster with Fibre Optic Link
MAXIMUM GAIN	32.65dB UPLINK
MAXIMUM INPUT	-14.0dBm UPLINK
MAXIMUM OUTPUT	18.65dBm UPLINK
ANTENNA TYPE:	Not applicable
CHANNEL SPACING:	25kHz
NUMBER OF CHANNELS:	486.0625MHz 486.2875MHz 486.3125MHz 486.5625MHz
FREQUENCY GENERATION:	N/A
MODULATION TYPE:	F3E
POWER SOURCE(s):	110Vac
TEST DATE(s):	9 th November 2005
ORDER No(s):	32747
APPLICANT:	Aerial Facilities Limited
ADDRESS:	Aerial House Asheridge Road Chesham Buckinghamshire HP5 1TU United Kingdom
TESTED BY:	----- J CHARTERS
APPROVED BY:	----- P GREEN PRODUCT MANAGER EMC

APPLICANT'S SUMMARY

EQUIPMENT UNDER TEST (EUT): 60-055902

EQUIPMENT TYPE: Booster with Fibre Optic Link

PURPOSE OF TEST: Certification

TEST SPECIFICATION(S): FCC RULES CFR 47, PART 90 SUBPART I

TEST RESULT: COMPLIANT Yes
No

APPLICANT'S CATEGORY: MANUFACTURER
IMPORTER
DISTRIBUTOR
TEST HOUSE
AGENT

APPLICANT'S ORDER No(s): 31474

APPLICANT'S CONTACT PERSON(S): Mr Peter Bradfield

E-mail address: Peterb@aerial.co.uk

APPLICANT: Aerial Facilities Limited

ADDRESS: Aerial House
Asheridge Road
Chesham
Buckinghamshire
HP5 1TU
United Kingdom

TEL: +44 (0)1494 777000

FAX: +44 (0)1494 778456

MANUFACTURER: Aerial Facilities Limited

EUT(S) COUNTRY OF ORIGIN: United Kingdom

TEST LABORATORY: TRL EMC

UKAS ACCREDITATION No: 0728

TEST DATE(S): 8th November 2005

TEST REPORT No: RU1201/6636

EQUIPMENT TEST / EXAMINATIONS REQUIRED

1.	TEST/EXAMINATION	RULE PART	APPLICABILITY	RESULT
	Spurious Emissions at Antenna Terminals (Intermodulation)	90.210	Yes	Complies

Note this report contains additional information and should be read in conjunction with TRL report RU1201/6636.

- 2. Product Use: Private Land Mobile Repeater Link System
- 3. System Description: The system operates by taking a wanted light signal in. This then converted to RF and passes through channel filters and amplifiers. The remote site fibre optic receiver was included in the test setup to convert the light back to RF.
- 4. Emission Designator: F3E
- 5. Temperatures: Ambient (Tnom) 18°C
- 6. Supply Voltages: Vnom 110Vac
 Note: Vnom voltages are as stated above unless otherwise shown on the test report page
- 7. Equipment Category:
 - Single channel []
 - Two channel []
 - Multi-channel [X]
- 8. Channel spacing:
 - Narrowband [X]
 - Wideband []
- 9. Test Location:
 - TRL Compliance
 - Up Holland [X]
 - Long Green []
- 10. Modifications made during test program: No modifications were performed.

COMPLIANCE TESTS

TRANSMITTER TEST - INTERMODULATION SPURIOUS EMISSIONS – CONDUCTED – PART 2.1053– UPLINK

Ambient temperature = 18°C
 Relative humidity = 60%
 Supply voltage = 110Vac

Radio Laboratory

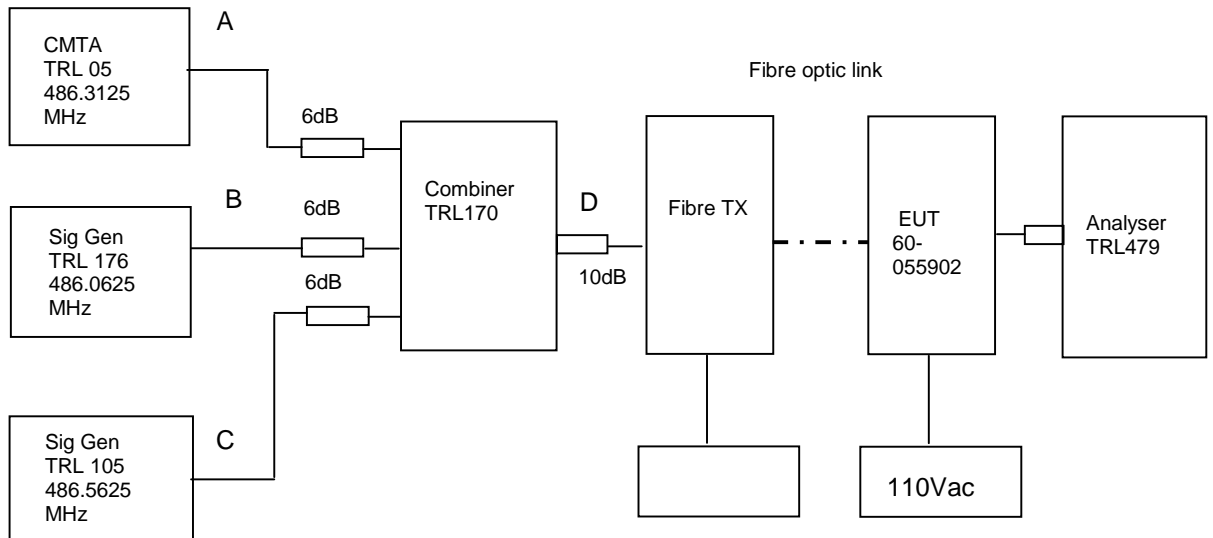

The Intermodulation and spurious products were measured with the fibre optic system operating at maximum input level. A three tone test was conducted using the equipment as above. The input power level was adjusted so the level at point D was the maximum input of -14.0dBm.

Sweep data is shown on the next page:

Test equipment used for intermodulation test

TYPE OF EQUIPMENT	MAKER/SUPPLIER	MODEL No	SERIAL No	TRL No	ACTUAL EQUIPMENT USED
SPECTRUM ANALYSER	ANRITSU	MS2665C	MT26089	479	X
SIGNAL GENERATOR	MARCONI	2042	119562/02	254	X
CMTA	ROHDE & SCHWARZ	CMTA52	894715/033	05	X
SIGNAL GENERATOR	MARCONI	2023	112224/040	UH105	X
COMBINER	ELCOM	RC-4-50	N/A	170	X

Intermodulation In Band

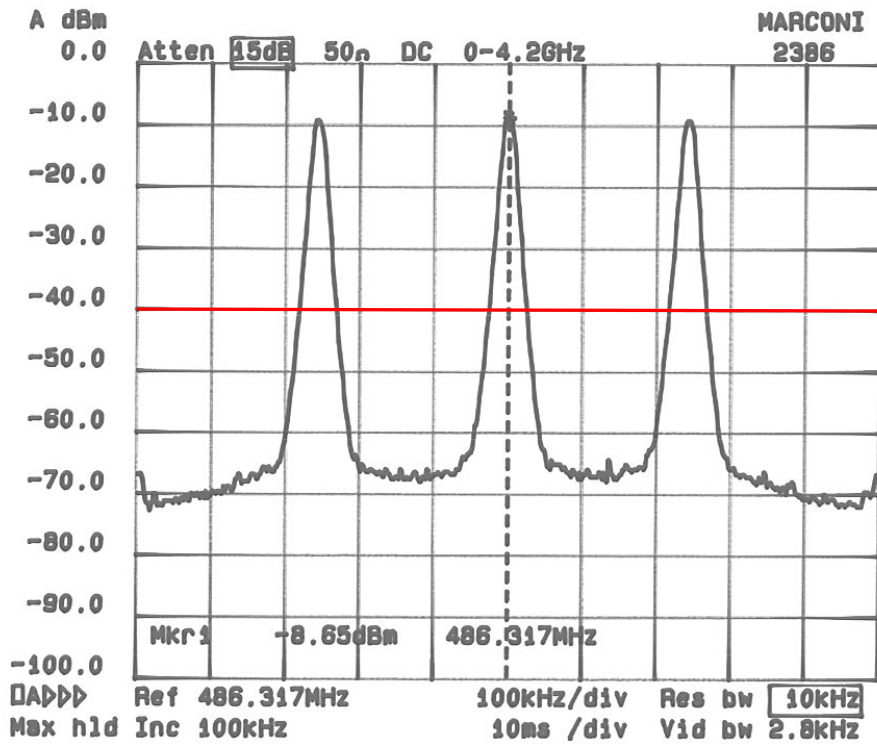

The above plot shows that all products (designated by ☆) are at least 30dB below the spurious limit. Based on the maximum input to the system.

Intermodulation Wideband

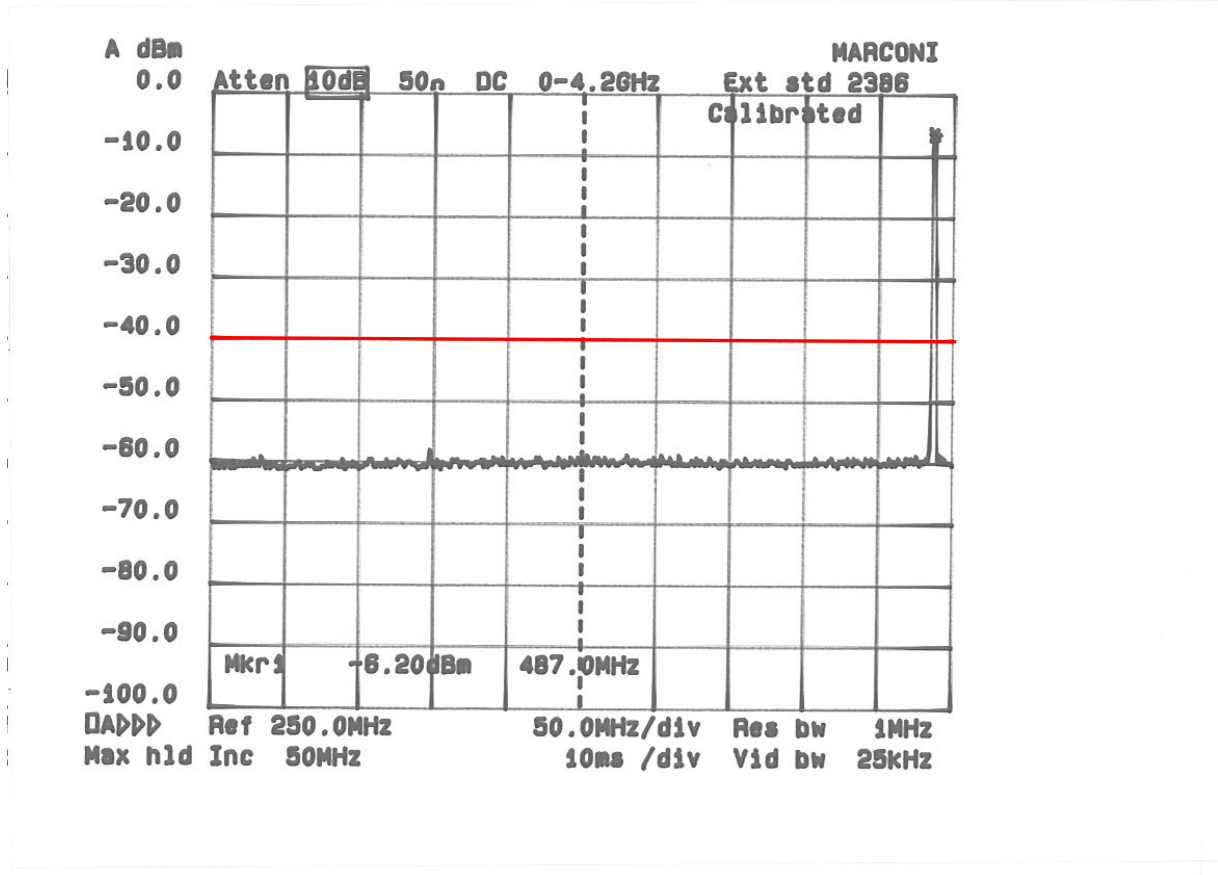

The above plot shows that there are no products outside the bands.
Based on the maximum input to the system.

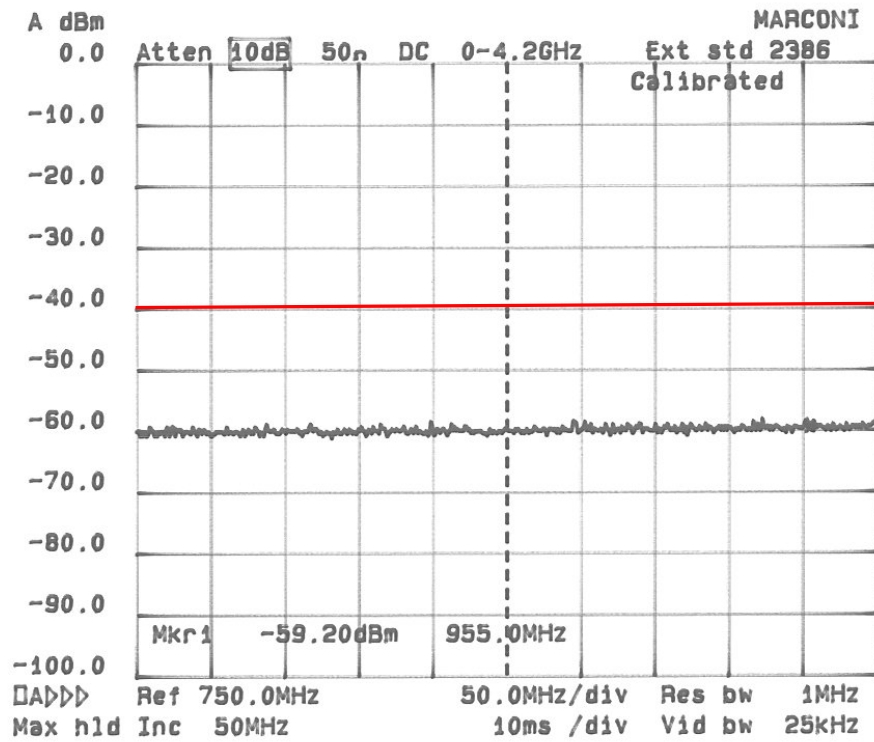

The above plot shows that there are no products outside the bands.
Based on the maximum input to the system.

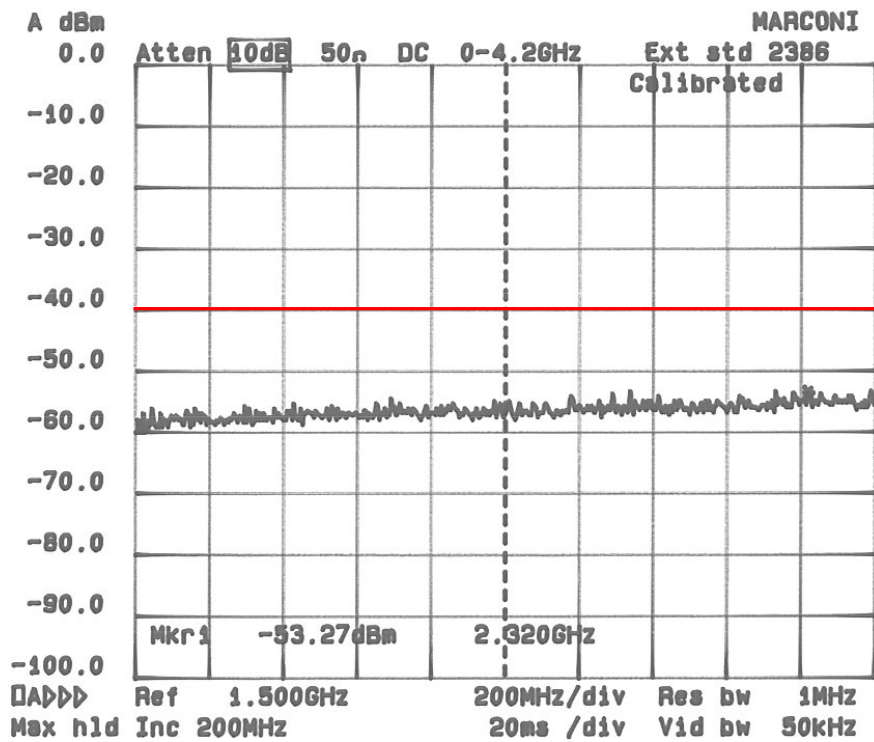

The above plot shows that there are no products outside the bands.
 Based on the maximum input to the system.

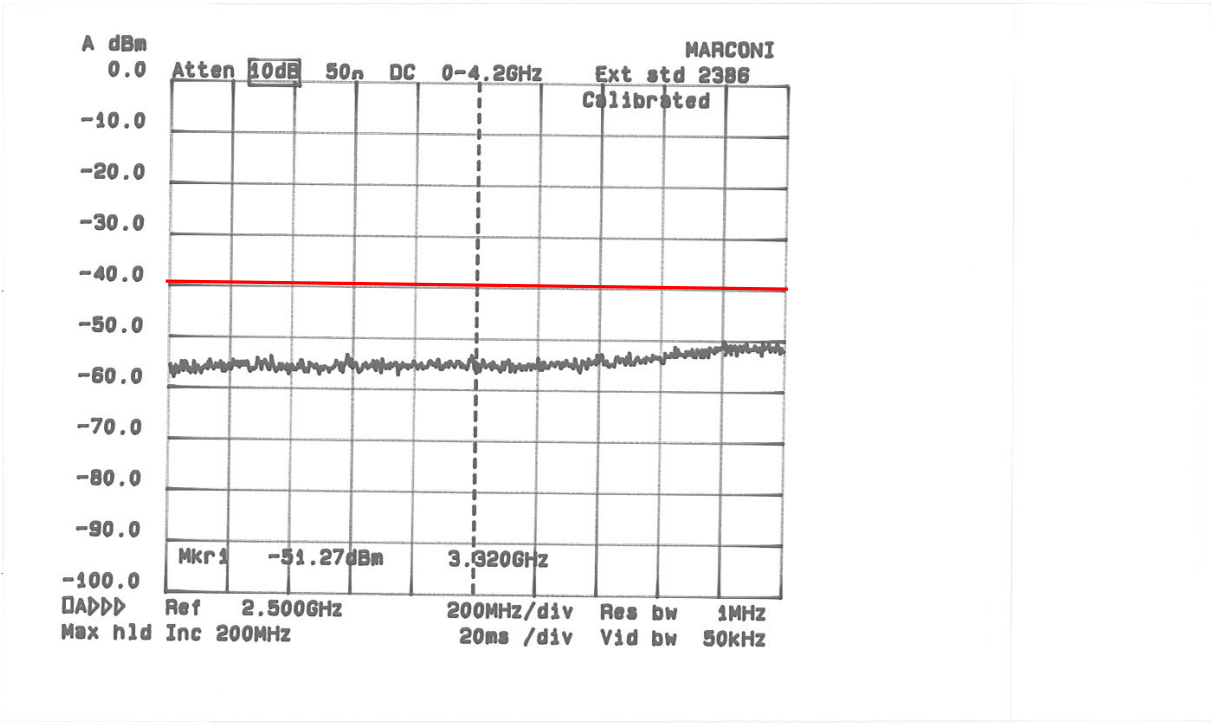

The above plot shows that there are no products outside the bands.
 Based on the maximum input to the system.

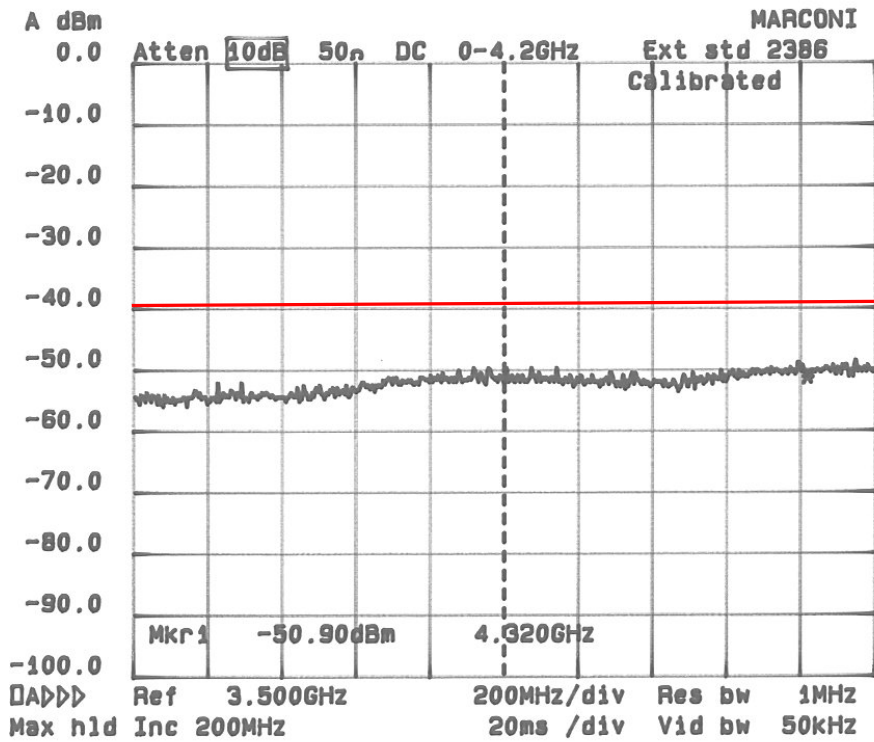

The above plot shows that there are no products outside the bands.
 Based on the maximum input to the system.

ANNEX A
TEST EQUIPMENT CALIBRATION DETAILS

TEST EQUIPMENT CALIBRATION DETAILS

TRL Number	Equipment Type	Manufacturer	Last Cal Calibration	Calibration Period
	3m Range ERP			
UH006	CAL	TRL	01/03/05	12
UH028	Log Periodic Ant	Schwarbeck	28/04/05	24
UH029	Bicone Antenna	Schwarbeck	27/04/05	24
UH041	Multimeter	AVOmeter	14/12/04	12
UH120	Spectrum Analyser	Marconi	15/03/05	12
UH122	Oscilloscope	Tektronix	07/06/05	24
UH162	ERP Cable Cal	TRL	23/05/05	12
UH179	Power Sensor	Marconi	14/12/04	12
UH228	Power Sensor	Marconi	17/01/05	12
UH253	1m Cable N type	TRL	10/01/05	12
UH254	1m Cable N type	TRL	10/01/05	12
L005	CMTA	R&S	22/10/04	12
L007	Loop Antenna	R&S	29/03/05	24
L138	1-18GHz Horn	EMCO	15/04/05	24
L139	1-18GHz Horn	EMCO	03/05/05	24
L176	Signal Generator	Marconi	31/01/05	12
L193	Bicone Antenna	Chase	12/10/03	24
L203	Log Periodic Ant	Chase	21/10/03	24
L254	Signal Generator	Marconi	13/12/04	12
L280	18GHz Cable	Rosenberger	10/01/05	12
L343	CCIR Noise Filter	TRL	07/06/05	12
	Temperature			
L426	Indicator	Fluke	14/12/04	12
L478	Signal Generator	R&S	19/05/04	12
L479	Analyser	Anritsu	05/10/04	12
L552	Signal Generator	Agilent	25/04/05	12