



TEST REPORT NO: RU1189/6432
COPY NO: .2.....
ISSUE NO: 2
FCC ID: NEOCCE-480N4

**REPORT ON THE CERTIFICATION TESTING OF
AERIAL FACILITIES LIMITED
60-055902
DOWNLINK ONLY
WITH RESPECT TO
THE FCC RULES CFR 47, PART 90 SUBPART I**

TEST DATE: 11th – 14th July 2005

TESTED BY: J CHARTERS
APPROVED BY: P GREEN
PRODUCT MANAGER
EMC
DATE: 2nd August 2005.....

Distribution:

- Copy Nos:
1. Aerial Facilities Limited
 2. TCB: CKC Certification Services
 3. TRL EMC

THIS DOCUMENT MAY BE REPRODUCED ONLY IN ITS ENTIRETY AND WITHOUT CHANGE



CONTENTS

	PAGE		
CERTIFICATE OF CONFORMITY & COMPLIANCE	3		
APPLICANT'S SUMMARY	4		
EQUIPMENT TEST CONDITIONS	5		
TESTS REQUIRED	5		
TEST RESULTS	6-31		
		ANNEX	
PHOTOGRAPHS		A	
PHOTOGRAPH No. 1: Test setup			
PHOTOGRAPH No. 2: Test setup			
TEST EQUIPMENT CALIBRATION DETAILS		B	
Notes:			
1. Component failure during test	YES		[]
	NO		[X]
2. If Yes, details of failure:			
3. The facilities used for the testing of the product contain in this report are FCC Listed.			



CERTIFICATE OF CONFORMITY & COMPLIANCE

FCC IDENTITY:	NEOCCE-480N4
PURPOSE OF TEST:	Certification
TEST SPECIFICATION:	FCC RULES CFR 47, PART 90 SUBPART I
TEST RESULT:	Compliant to Specification
EQUIPMENT UNDER TEST:	60-055902 (Downlink only)
EQUIPMENT TYPE:	Booster with Fibre Optic Link
MAXIMUM GAIN	57.2dB Downlink
MAXIMUM INPUT	-82.0dBm Downlink
MAXIMUM OUTPUT	-24.2 dBm Downlink
ANTENNA TYPE:	Not applicable
CHANNEL SPACING:	25kHz
NUMBER OF CHANNELS:	483.0626MHz 483.2875MHz 483.3125MHz 483.5625MHz
FREQUENCY GENERATION:	N/A
MODULATION TYPE:	F3E
POWER SOURCE(s):	110Vac
TEST DATE(s):	11 th – 14 th July 2005
ORDER No(s):	31474
APPLICANT:	Aerial Facilities Limited
ADDRESS:	Aerial House Asheridge Road Chesham Buckinghamshire HP5 1TU United Kingdom
TESTED BY:	----- J CHARTERS
APPROVED BY:	----- P GREEN PRODUCT MANAGER EMC

EQUIPMENT TEST / EXAMINATIONS REQUIRED

1.	TEST/EXAMINATION	RULE PART	APPLICABILITY	RESULT
	RF Gain	90.205 2.1046	Yes	Complies
	Audio Frequency Response	TIA EIA-603.3.2.6	N/A	N/A
	Audio Low-Pass Filter Response	TIA EIA-603.3.2.6	N/A	N/A
	Modulation Limiting	TIA EIA-603.3.2.6	N/A	N/A
	Occupied Bandwidth	90.210 2.1049	Yes	Complies
	Spurious Emissions at Antenna Terminals	90.210	Yes	Complies
	Field Strength of Spurious Emissions	90.210 2.1053	Yes	Complies
	Frequency Stability	90.213	Yes	Complies
	Transient behaviour	90.214	Yes	Complies

2. Product Use: Private Land Mobile Repeater Link System
3. System Description: The system operates by taking a wanted RF signal in. The signal then goes through channel filters and amplifiers after this it is converted to light and sent down a fibre optic link to a remote site. At the remote site the signal is converted back to RF. The remote site fibre optic receiver was included in the test setup to convert the light back to RF.
4. Emission Designator: F3E
5. Temperatures: Ambient (Tnom) 26°C
6. Supply Voltages: Vnom 110Vac
- Note: Vnom voltages are as stated above unless otherwise shown on the test report page
7. Equipment Category: Single channel []
Two channel []
Multi-channel [X]
8. Channel spacing: Narrowband [X]
Wideband []
9. Test Location: TRL Compliance Services
Up Holland [X]
Long Green []
10. Modifications made during test program: No modifications were performed.

COMPLIANCE TESTS

TRANSMITTER TEST – GAIN – CONDUCTED – PART 2.1046 – DOWNLINK

Ambient temperature = 26°C Radio Laboratory
 Relative humidity = 40%
 Supply voltage = 110Vac
 Channel number = See test results

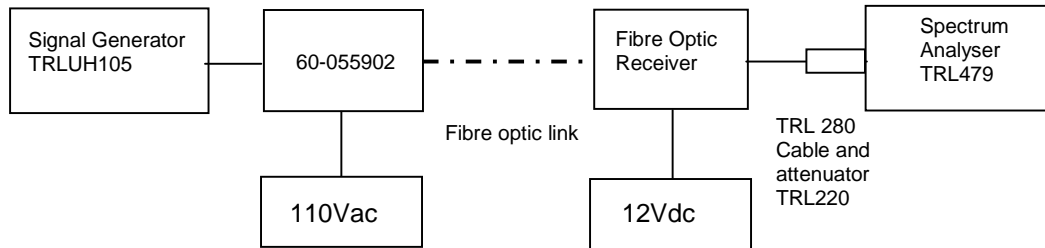

Frequency MHz	Signal Generator Input Level dBm	Cable & Attenuator Loss dB	Level at Spectrum Analyser dBm	Gain dB	Gain after 10dB increase input signal level dBm	Measured Output Power dBm
483.0625	-82.0	27.0	-52.2	-56.8	-50.2	-25.2
483.2875	-82.0	27.0	-51.8	- 57.2	-50.7	-24.2
483.5625	-82.0	27.0	-52.8	-56.2	-50.3	-25.8

The test was setup as above. The signal generator was to simulate an input signal to the system from a transmitter and the analyzer used to obtain the output level from the system.

TYPE OF EQUIPMENT	MAKER/SUPPLIER	MODEL No	SERIAL No	TRL No	ACTUAL EQUIPMENT USED
SPECTRUM ANALYSER	ANRITSU	MS2665C	MT26089	479	X
ATTENUATOR	BIRD	8304-200	N/A	103	
ATTENUATOR	BIRD	8304-300-N	N/A	220	X
CABLE	ROSENBERGER	MICRO COAX	N/A	280	X
SIGNAL GENERATOR	MARCONI	2023	112224/040	UH105	X

**TRANSMITTER TEST - INTERMODULATION SPURIOUS EMISSIONS – CONDUCTED – PART 2.1053–
DOWNLINK**

Ambient temperature = 24°C
 Relative humidity = 43%
 Supply voltage = 110Vac

Radio Laboratory

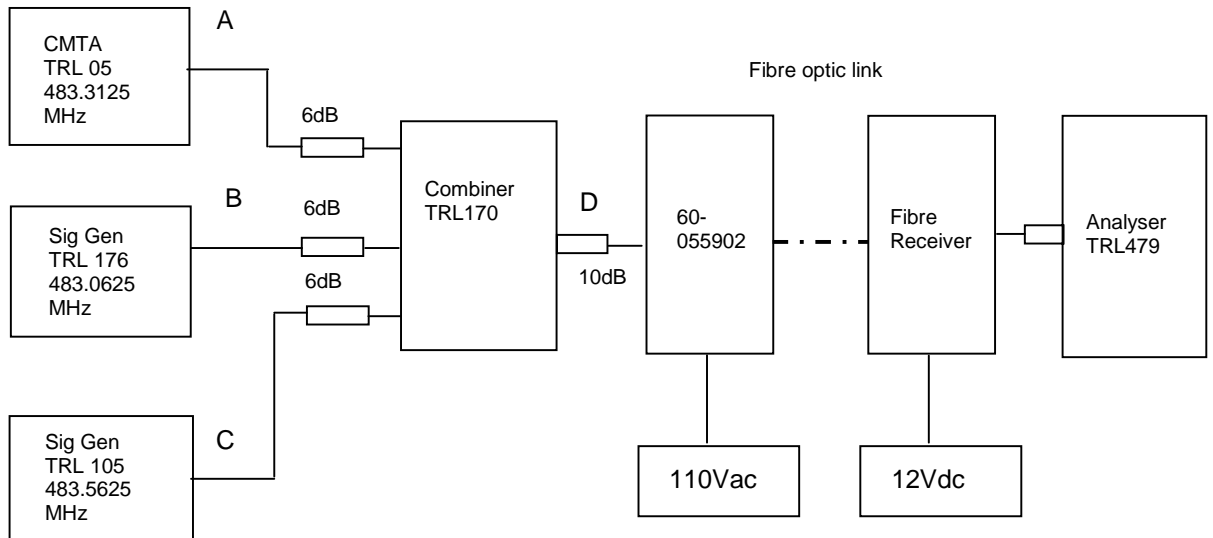

The Intermodulation and spurious products were measured with the fibre optic system operating at maximum input level. A three tone test was conducted using the equipment as above. The input power level was adjusted so the level at point D was the maximum input of -82.0dBm.

Sweep data is shown on the next page:

Test equipment used for intermodulation test

TYPE OF EQUIPMENT	MAKER/SUPPLIER	MODEL No	SERIAL No	TRL No	ACTUAL EQUIPMENT USED
SPECTRUM ANALYSER	ANRITSU	MS2665C	MT26089	479	X
SIGNAL GENERATOR	MARCONI	2042	119562/02	254	X
CMTA	ROHDE & SCHWARZ	CMTA52	894715/033	05	X
SIGNAL GENERATOR	MARCONI	2023	112224/040	UH105	X
COMBINER	ELCOM	RC-4-50	N/A	170	X

Intermodulation In Band

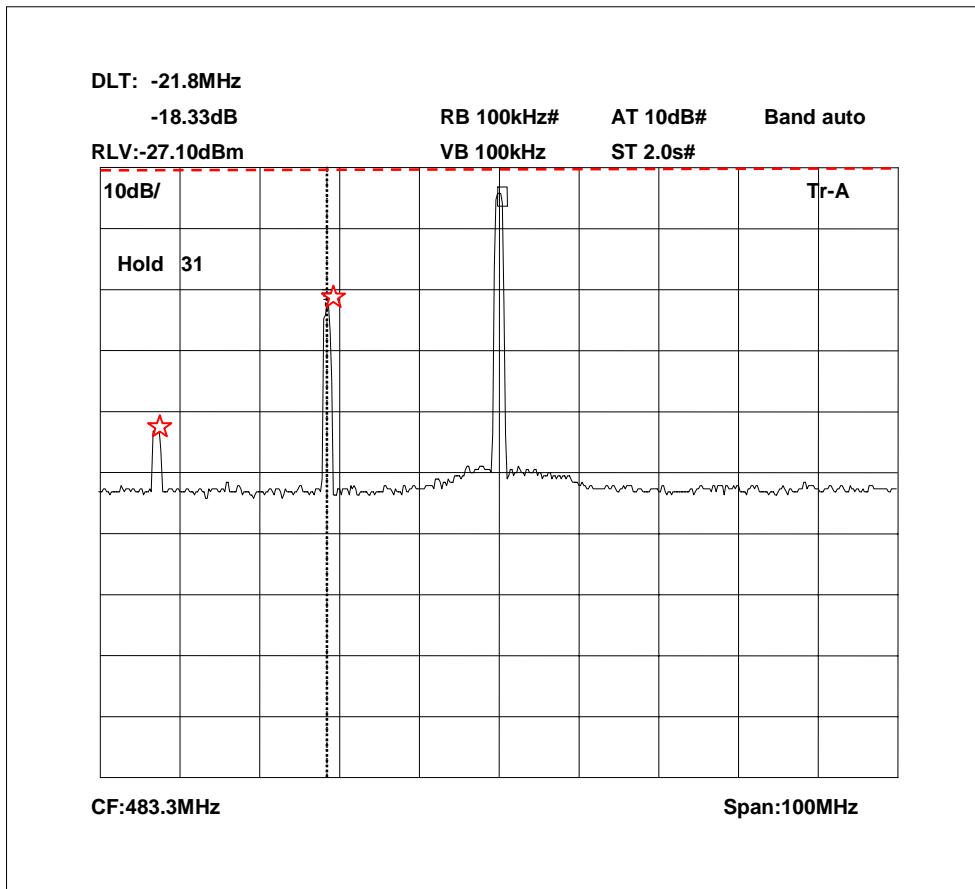

The above plot shows that all products (designated by ☆) are at least 20dB below the spurious limit.
Based on the maximum input to the system.

Intermodulation Wideband

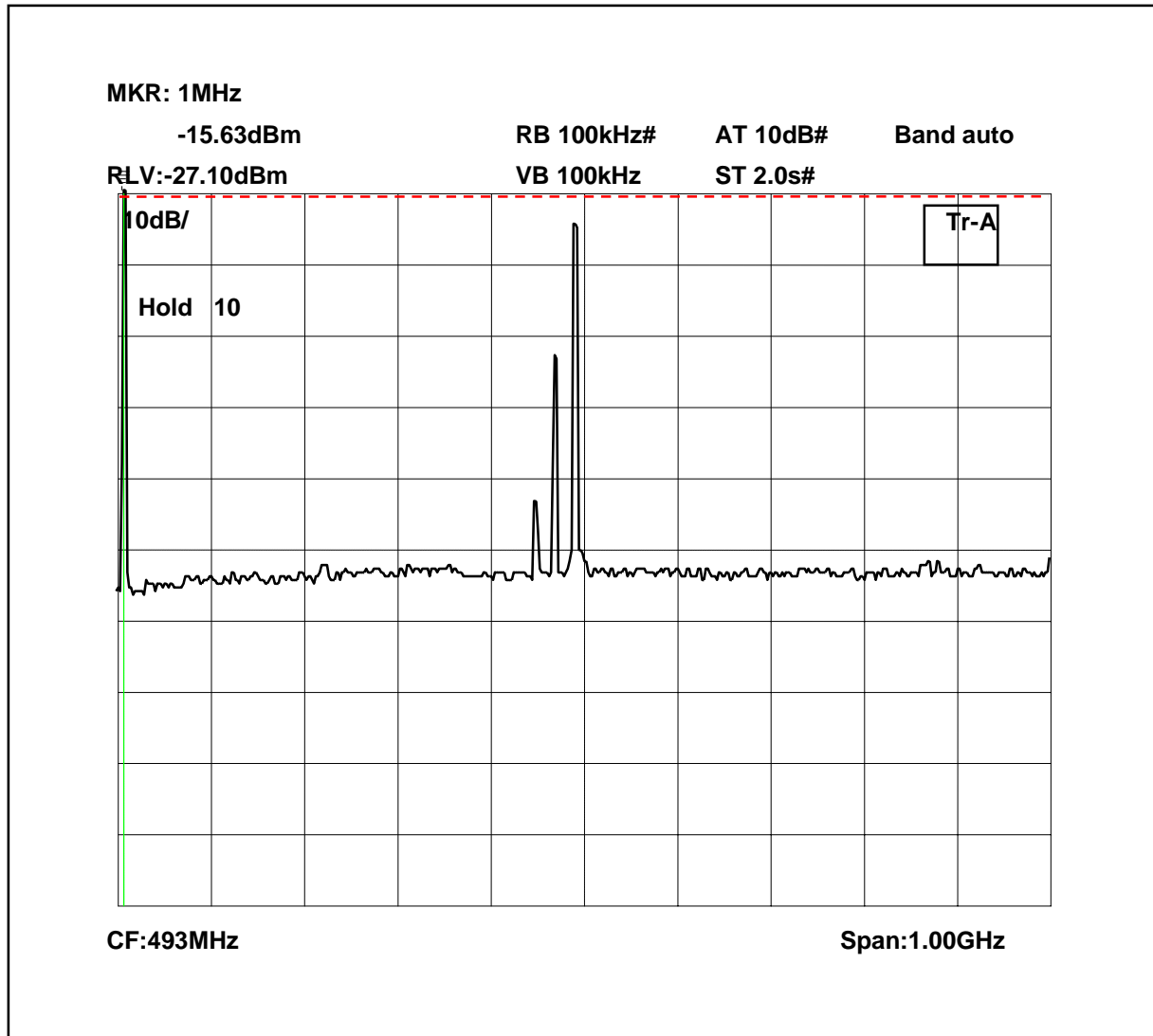

The above plot shows that there are no products outside the bands.
Based on the maximum input to the system.

TRANSMITTER TESTS

MODULATED BANDWIDTH TEST – CONDUCTED – Part 2.1049– DOWNLINK

Ambient temperature = 26°C
 Relative humidity = 40%
 Supply voltage = 110Vac
 Channel number = See test results

Radio Laboratory

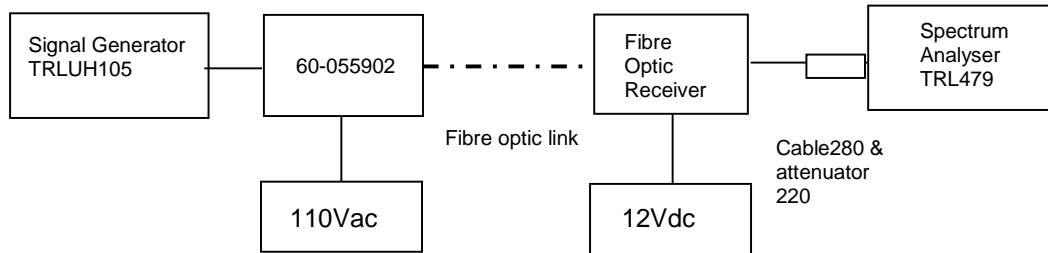

This test was performed to show that the fibre optic system does not alter the input signal in any way. The input signal was set to the maximum input level (0dBm) and modulated with a 2500Hz tone. The plots show the signal measured at the signal generator and the signal measured at the output of the EUT.

Note: The cables and attenuators had the following losses.

1. Cable TRL280 and Attenuator TRL220 between EUT and spectrum analyser= 27.0dB
2. Cable between signal generator and EUT = 0.22dB

TYPE OF EQUIPMENT	MAKER/SUPPLIER	MODEL No	SERIAL No	TRL No	ACTUAL EQUIPMENT USED
SPECTRUM ANALYSER	ANRITSU	MS2665C	MT26089	479	X
ATTENUATOR	BIRD	8304-200	N/A	103	
ATTENUATOR	BIRD	8304-300-N	N/A	220	X
CABLE	ROSENBERGER	MICRO COAX	N/A	280	X
SIGNAL GENERATOR	MARCONI	2023	112224/040	UH105	X

483.0625MHz Signal Generator deviation set to 5kHz

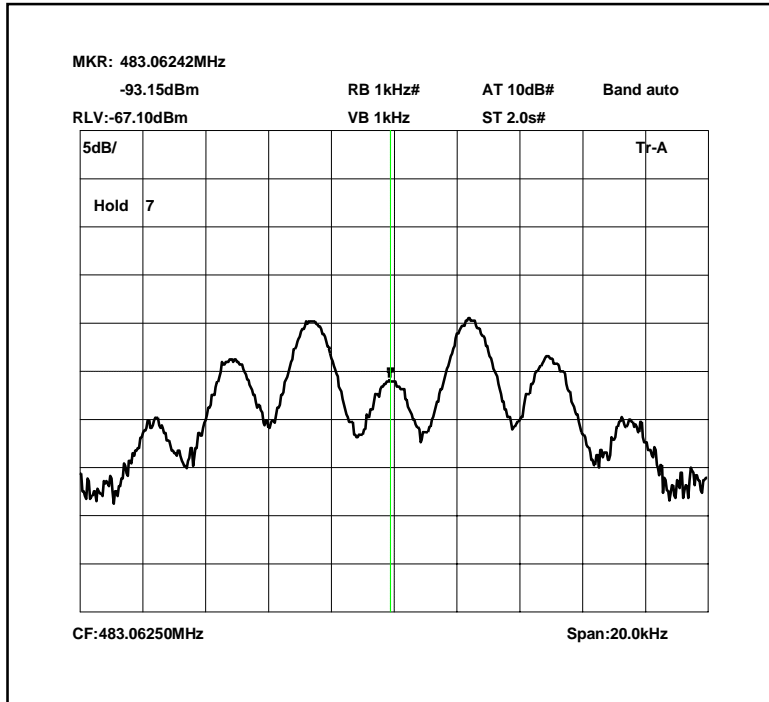

483.0625MHz Signal Generator amplifier and fibre optic system deviation set to 5kHz

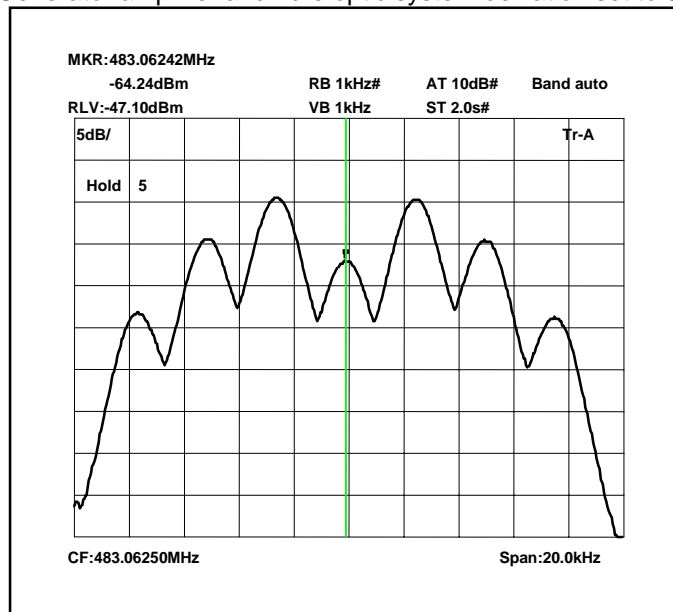

The above plots depicting the output waveshape show no measurable distortion visible when compared to the input signal.

483.2875MHz Signal Generator deviation set to 5kHz

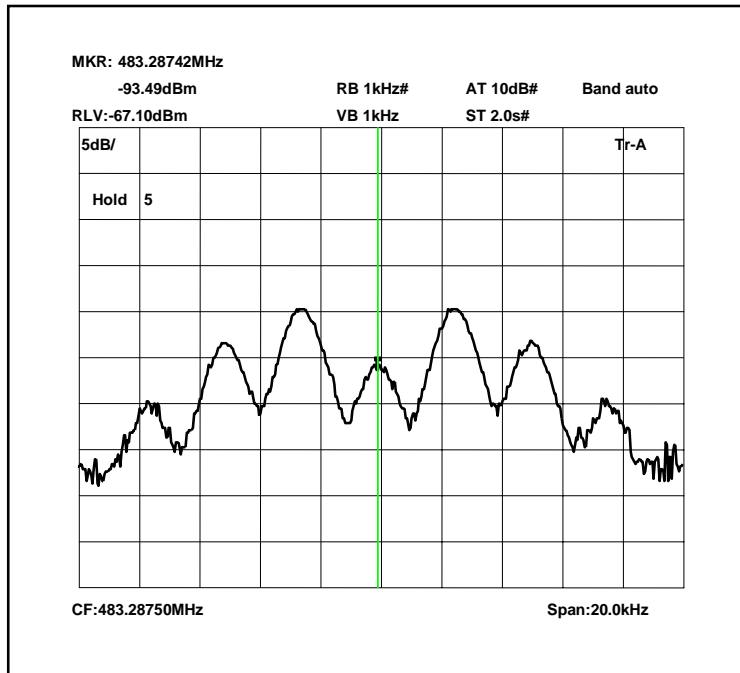

483.2875MHz Signal Generator amplifier and fibre optic system deviation set to 5kHz

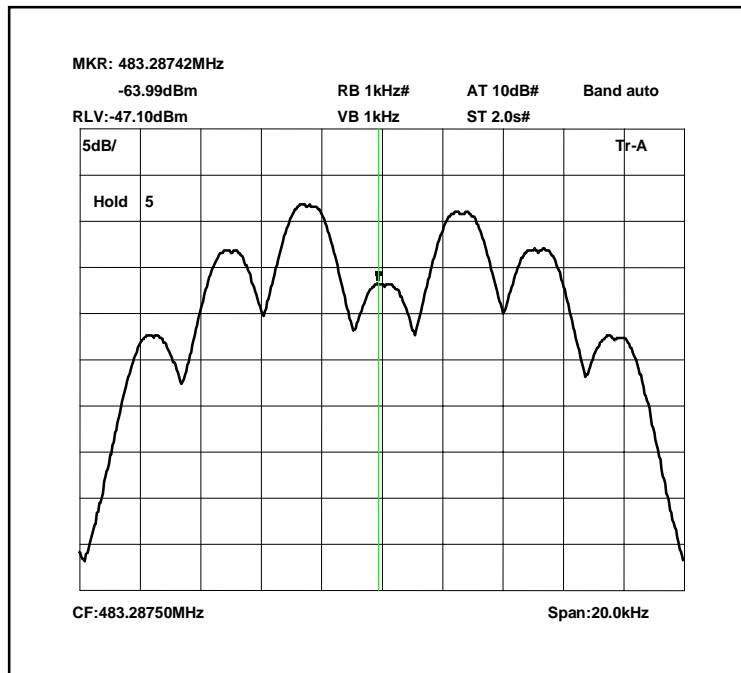

The above plots depicting the output waveshape show no measurable distortion visible when compared to the input signal.

483.5625MHz Signal Generator deviation set to 5kHz

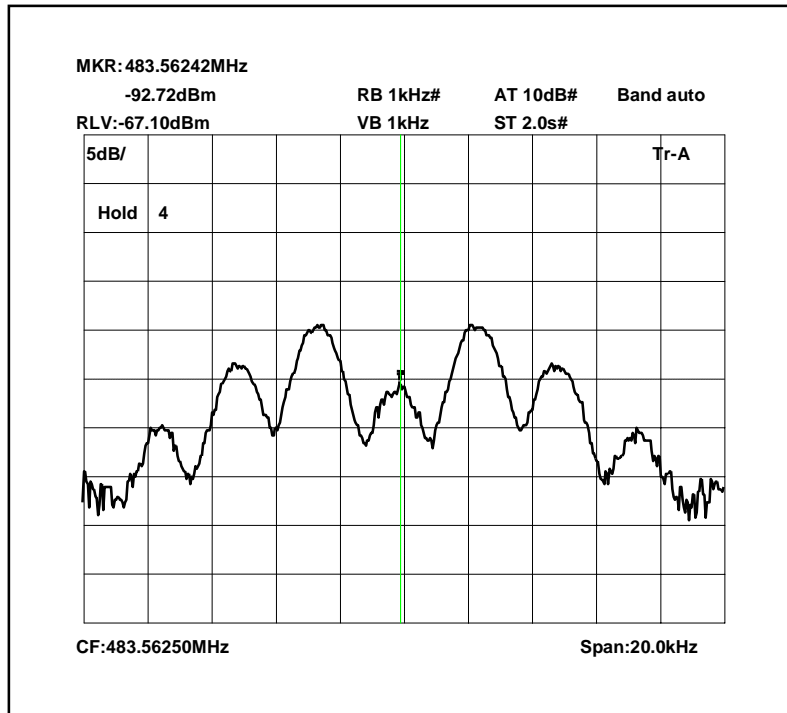

483.5625MHz Signal Generator amplifier and fibre optic system deviation set to 5kHz

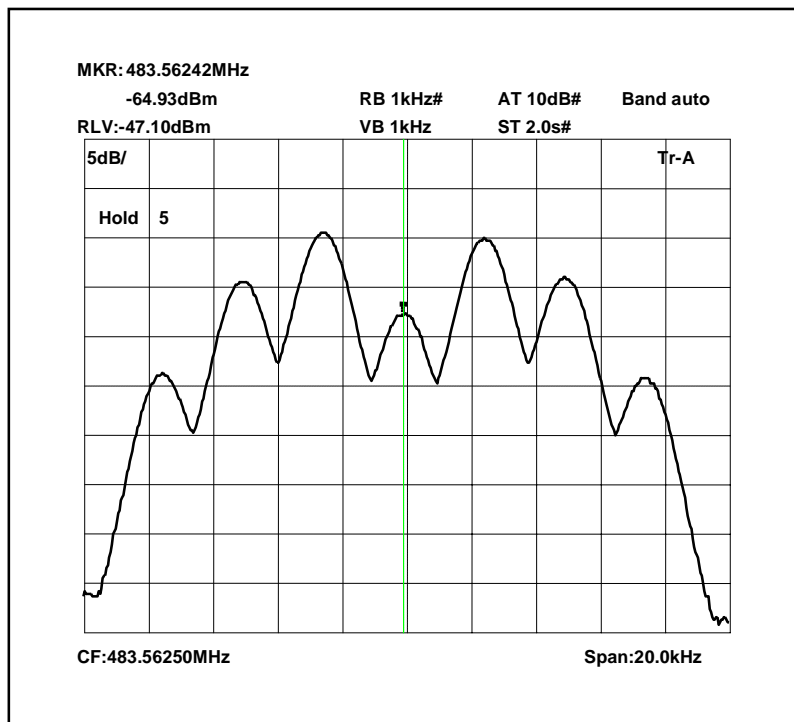

The above plots depicting the output waveshape show no measurable distortion visible when compared to the input signal.

TRANSMITTER TESTS

FIBRE OPTIC SYSTEM SPURIOUS EMISSIONS – CONDUCTED – Part 2.1053 – DOWNLINK

Ambient temperature = 26°C
 Relative humidity = 40%
 Supply voltage = 110Vac

Radio Laboratory Test Signal = F3E

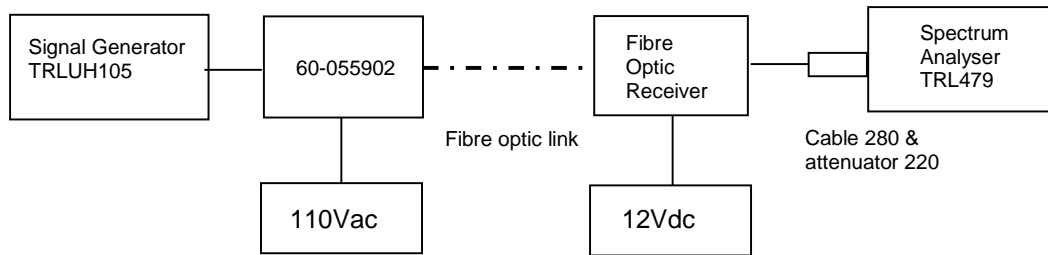

The test was set up as per the diagram. The level at the input was adjusted to compensate for the loss of the interconnecting cable. The unit was tested operating at maximum power and on three test frequencies.

The Spurious limit was calculated as follows:

On any frequency removed from the assigned frequency by more than 250% of the authorised bandwidth

At least $43 + 10 \log P_{dB}$

$$(10 \log P_{watts}) - (43 + 10 \log (P_{watts} * 1000)) = \text{LIMIT} = -13 \text{ dBm}$$

Test Result

No significant emissions within 20dBm of limit.

The test equipment used for the Transmitter Conducted Emissions:

TYPE OF EQUIPMENT	MAKER/SUPPLIER	MODEL No	SERIAL No	TRL No	ACTUAL EQUIPMENT USED
SPECTRUM ANALYSER	ANRITSU	MS2665C	MT26089	479	X
ATTENUATOR	BIRD	8304-200	N/A	103	
ATTENUATOR	BIRD	8304-300-N	N/A	220	X
CABLE	ROSENBERGER	MICRO COAX	N/A	280	X
SIGNAL GENERATOR	MARCONI	2023	112224/040	UH105	X

Conducted emissions 483.0625 MHz 0 – 2 GHz

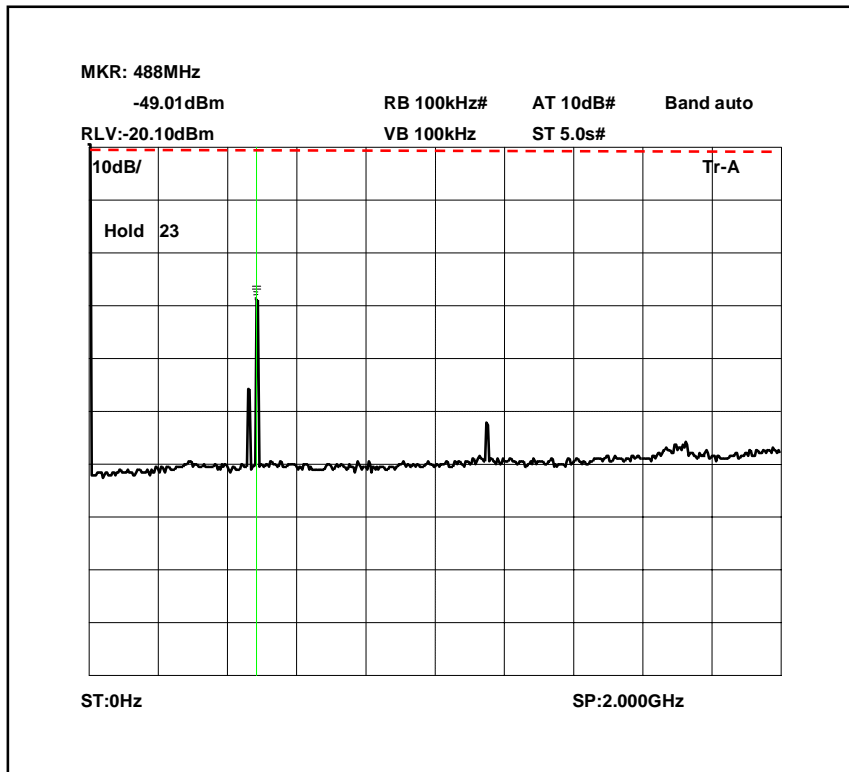

Conducted emissions 483.0625 MHz 2 – 5 GHz

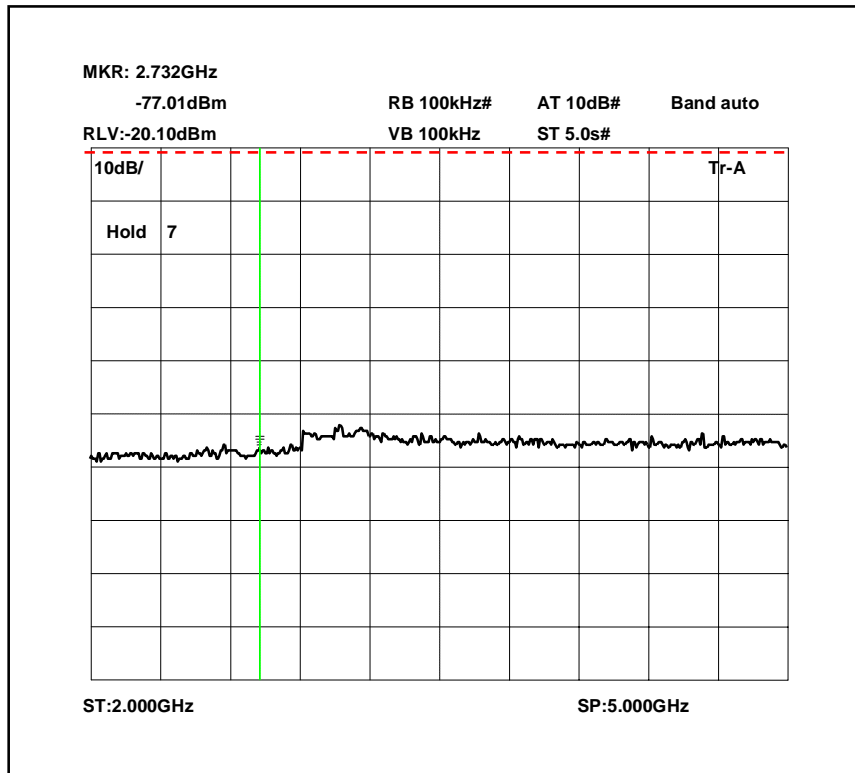

Conducted emissions 483.2875 MHz 0 – 2.0 GHz

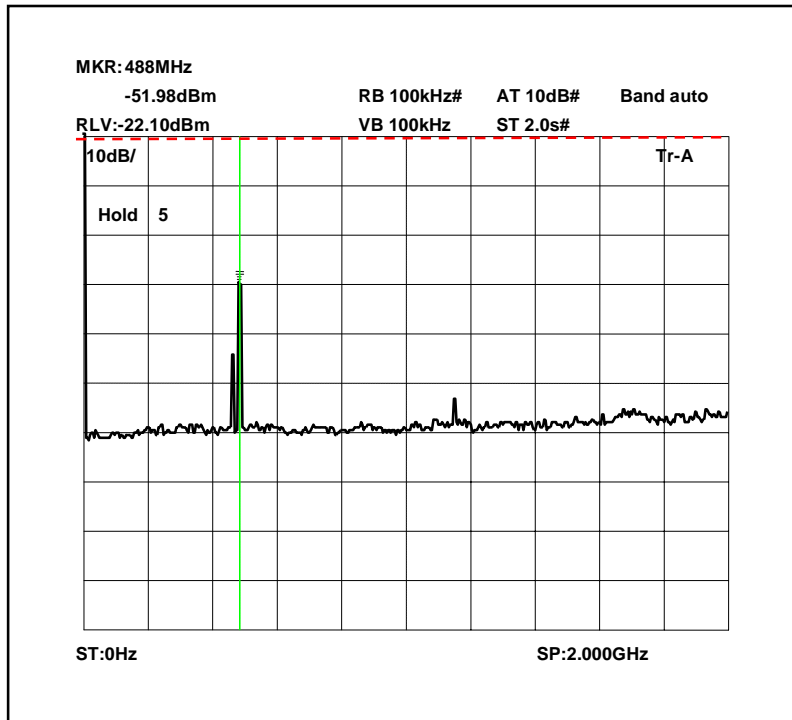

Conducted emissions 483.2875 MHz 2.0 – 5.0 GHz

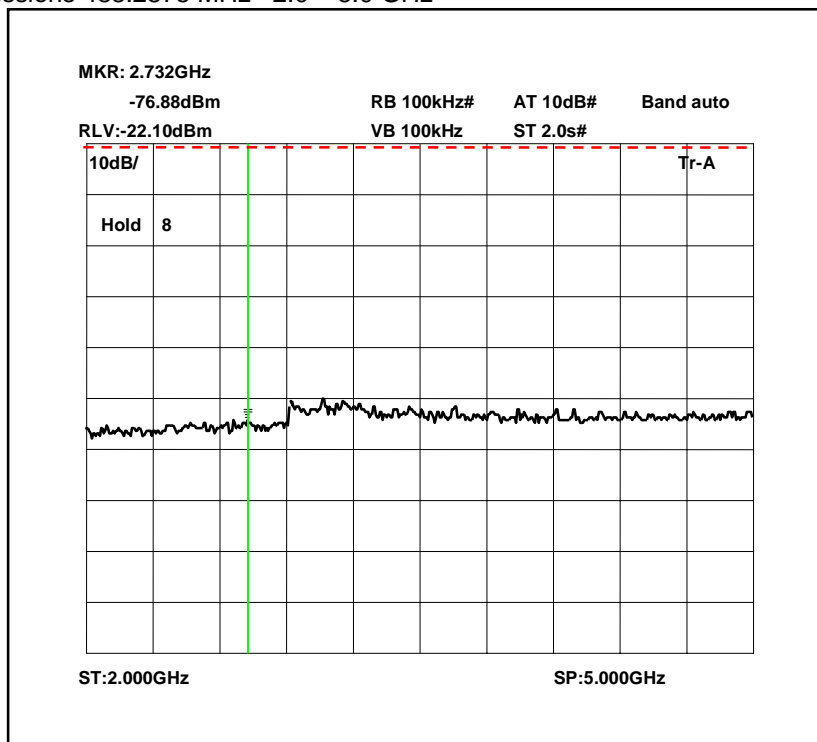

Conducted emissions 483.5625 MHz 0 – 2 GHz

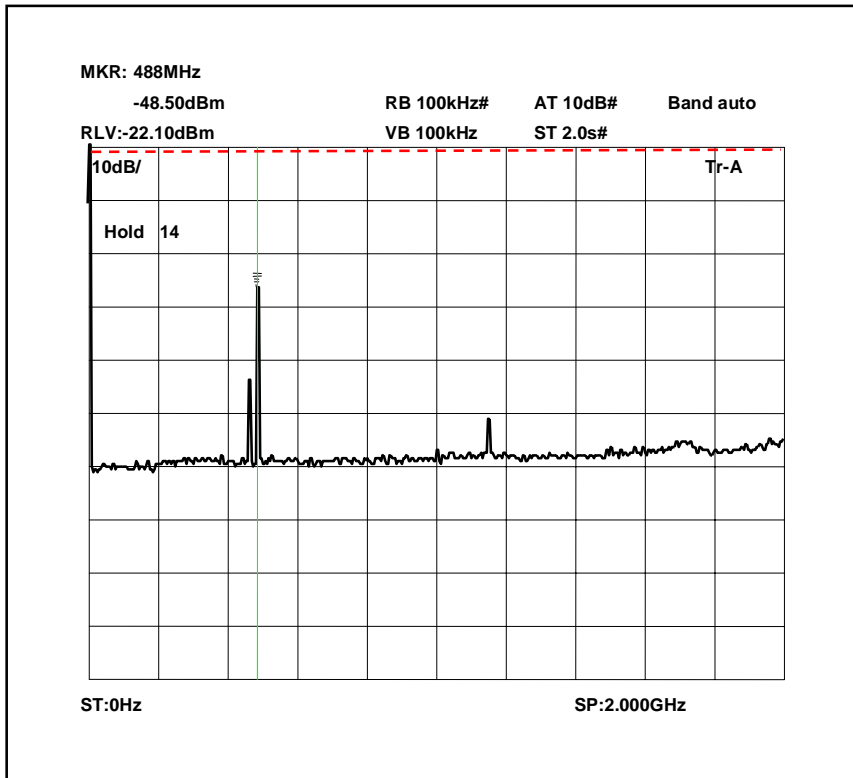

Conducted emissions 483.5625 MHz 2 – 5 GHz

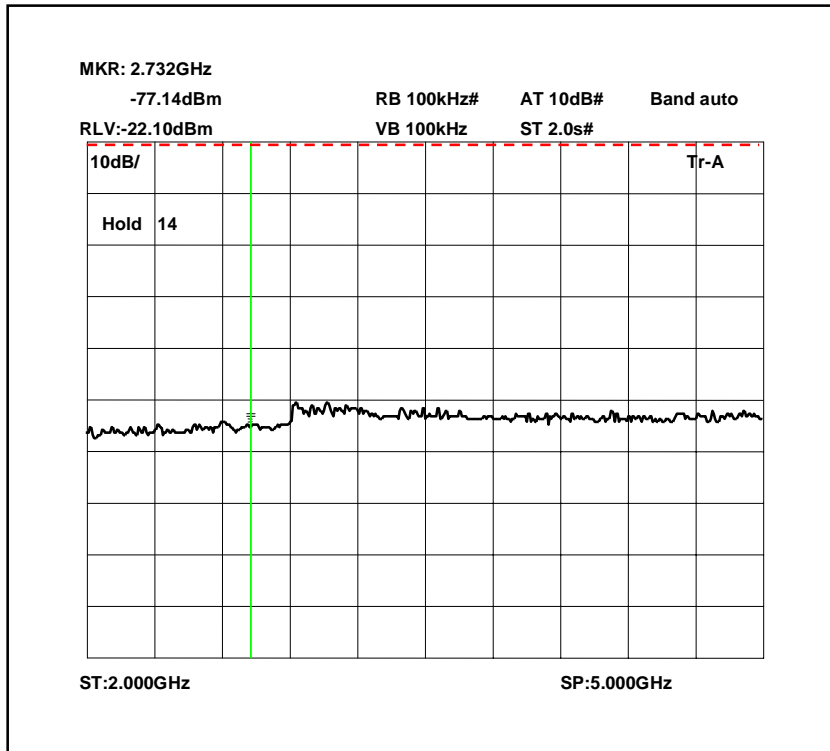

TRANSMITTER TESTS

TRANSMITTER SPURIOUS EMISSIONS – RADIATED – Part 2.1053– DOWNLINK

Ambient temperature = 26°C
 Relative humidity = 34%
 Conditions = OATS
 Supply voltage = 110Vac
 Supply Frequency = N/A

Test Signal = F3E

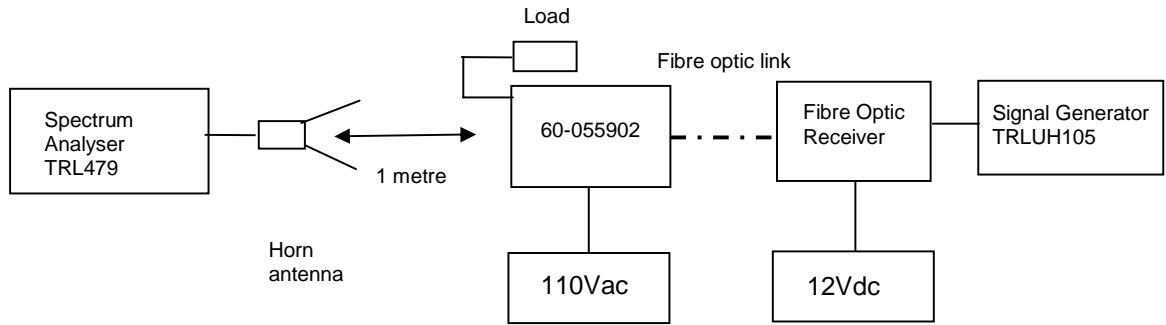

The test was set up as per the diagram. The level at the input was adjusted to compensate for the loss of the interconnecting cable. The unit was tested operating maximum power on three test frequencies with a 50 ohm load on the output. The unit was also tested with the signal generator replaced by another 50ohm load.

The Spurious limit was calculated as follows:

On any frequency removed from the assigned frequency by more that 250% of the authorised bandwidth

At least 43 + 10 log PdB

$$(10\log P_{\text{watts}}) - (43 + 10\log (P_{\text{watts}} * 1000)) = \text{LIMIT} = -13 \text{ dBm}$$

The test equipment used for the Transmitter Spurious Emissions:

TYPE OF EQUIPMENT	MAKER/SUPPLIER	MODEL No	SERIAL No	TRL No	ACTUAL EQUIPMENT USED
SPECTRUM ANALYSER	ANRITSU	MS2665C	MT26089	479	X
HORN	EMCO	3115	9010-3581	139	X
ATTENUATOR	BIRD	8304-300-N	N/A	220	X
ATTENUATOR	BIRD	8308-100	N/A	112	X
CABLE	ROSENBERGER	MICRO COAX	N/A	280	X
SIGNAL GENERATOR	MARCONI	2023	112224/040	UH105	X

Radiated emissions 483.0625 MHz 0 – 2 GHz

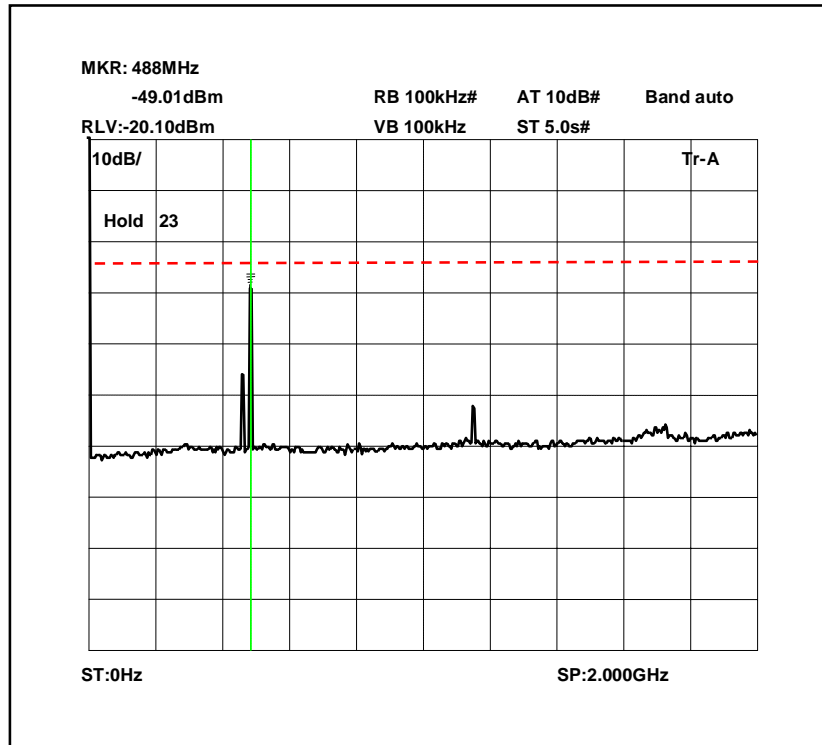

Radiated emissions 483.0625 MHz 2 – 5 GHz

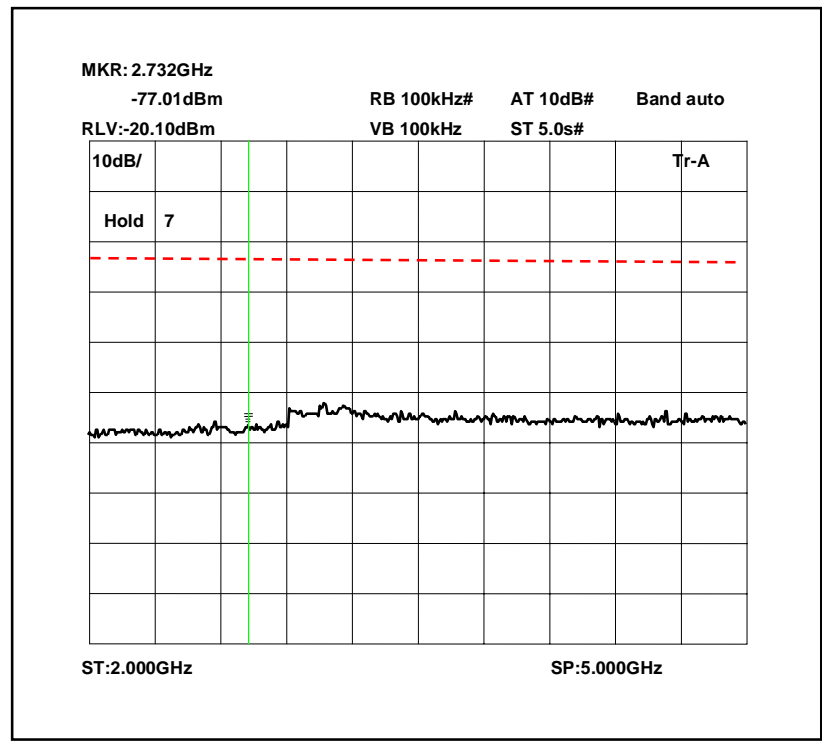

The above test results show that there were no emissions within 20dBs of the -13dBm limit.

Radiated emissions 483.5625 MHz 0 – 2 GHz

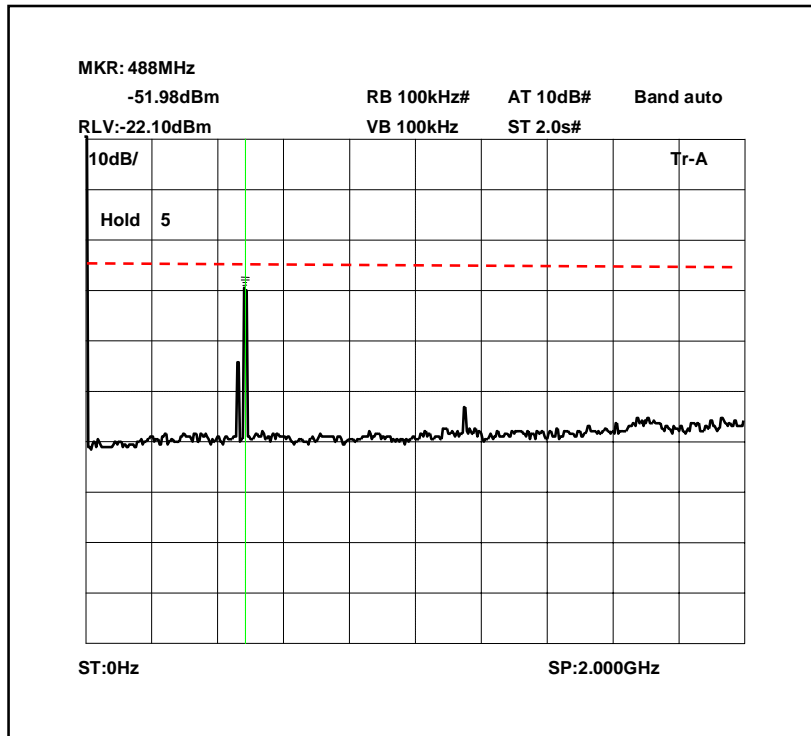

Radiated emissions 483.5625 MHz 2 – 5 GHz

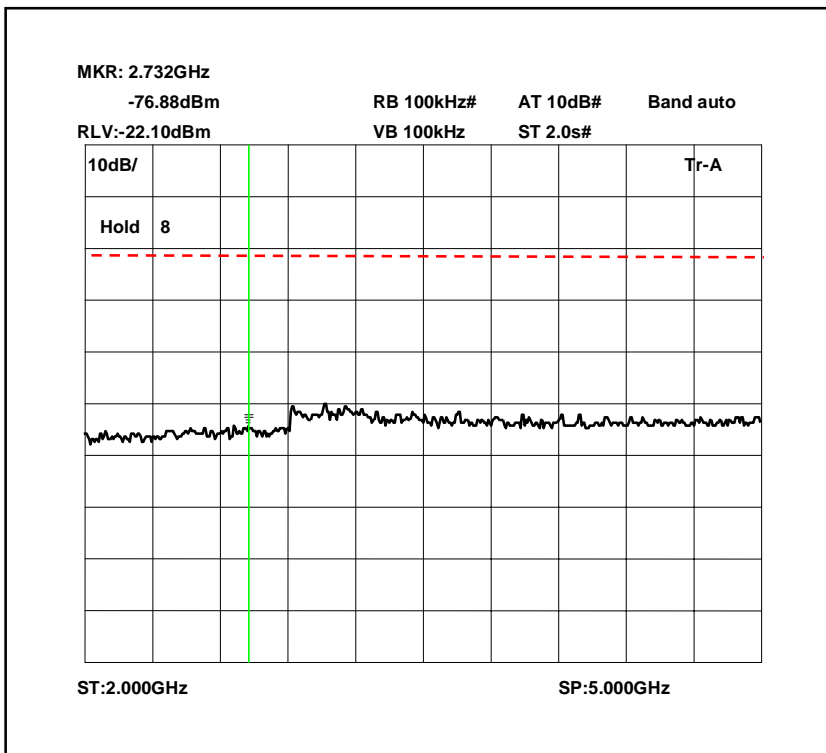

The above test results show that there were no emissions within 20dBs of the -13dBm limit.

Radiated emissions no input signal 0 – 2 GHz

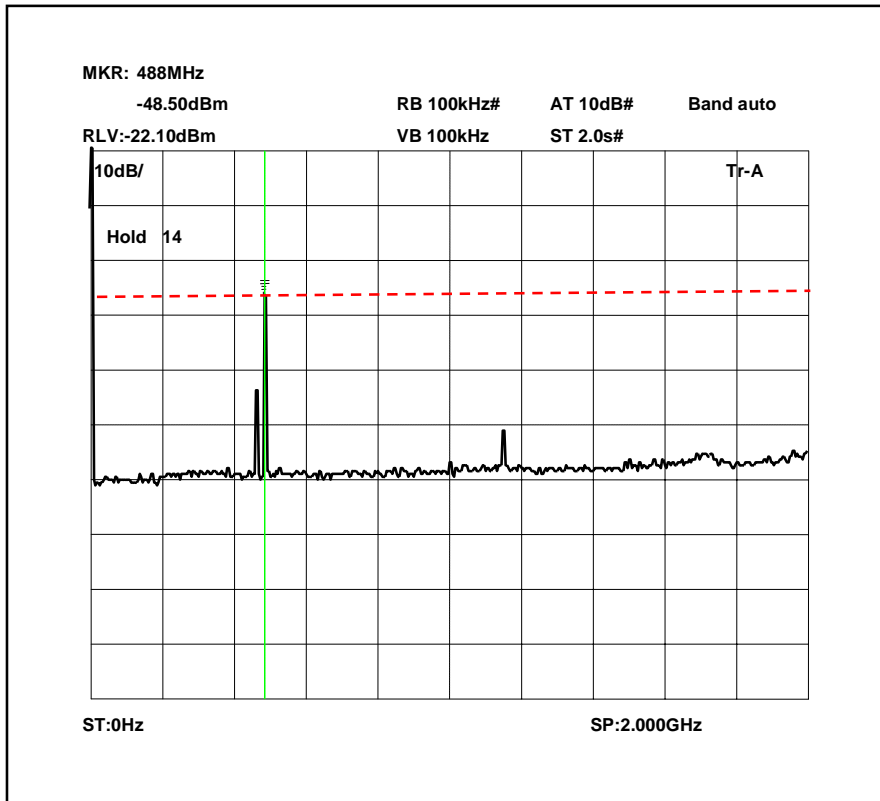

Radiated emissions no input signal 2 – 4 GHz

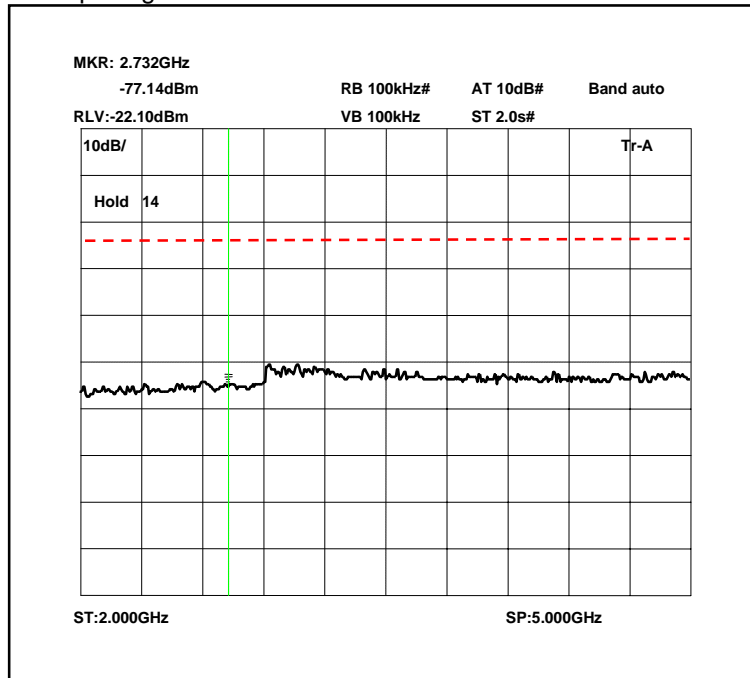

The above test results show that there were no emissions within 20dBs of the -13dBm limit.

TRANSMITTER TESTS

FIBRE OPTIC SYSTEM FREQUENCY STABILITY – VOLTAGE – Part 90.213– UPLINK

Ambient temperature = 24°C
 Relative humidity = 47%
 Supply voltage = 110Vac

Radio Laboratory
 Test Signal = F3E

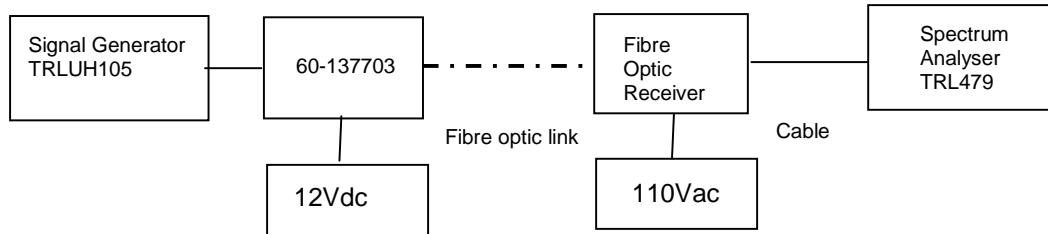

The test was set up as per the diagram. The level at the input was set to 0 dBm. The units were tested operating maximum power on the frequencies as per the table below. One unit was held constant at its nominal operating voltage, 110Vac, while the nominal operating voltage of the other unit, +12Vdc was varied over the range 85% to 115%. The units were then tested with the +12Vdc unit held constant at its nominal voltage and the other unit voltage varied over the 85% to 115%. The results can be seen in the tables below and on the plots overleaf. For reference the frequency variations are compared to a 2.5ppm limit in the plots.

Results for 60-137703 +12Vdc varied over the 85% - 115 % range.

VOLTAGE %	FREQUENCY 483.0625MHz	PPM	FREQUENCY 483.2875MHz	PPM	FREQUENCY 483.5625MHz	PPM
85	483.0629MHz	0.828	483.28790MHz	0.828	483.56278MHz	0.579
90	483.06282MHz	0.662	483.28790MHz	0.828	483.56274MHz	0.496
95	483.06282MHz	0.662	483.28790MHz	0.828	483.56278MHz	0.579
100	483.06282MHz	0.662	483.28794MHz	0.910	483.56274MHz	0.496
105	483.06282MHz	0.662	483.28794MHz	0.910	483.56278MHz	0.579
110	483.06282MHz	0.662	483.28786MHz	0.745	483.56274MHz	0.496
115	483.06282MHz	0.662	483.28786MHz	0.745	483.56274MHz	0.496

Downlink - 60-055902 - 483.0625MHz Frequency Stability - Voltage

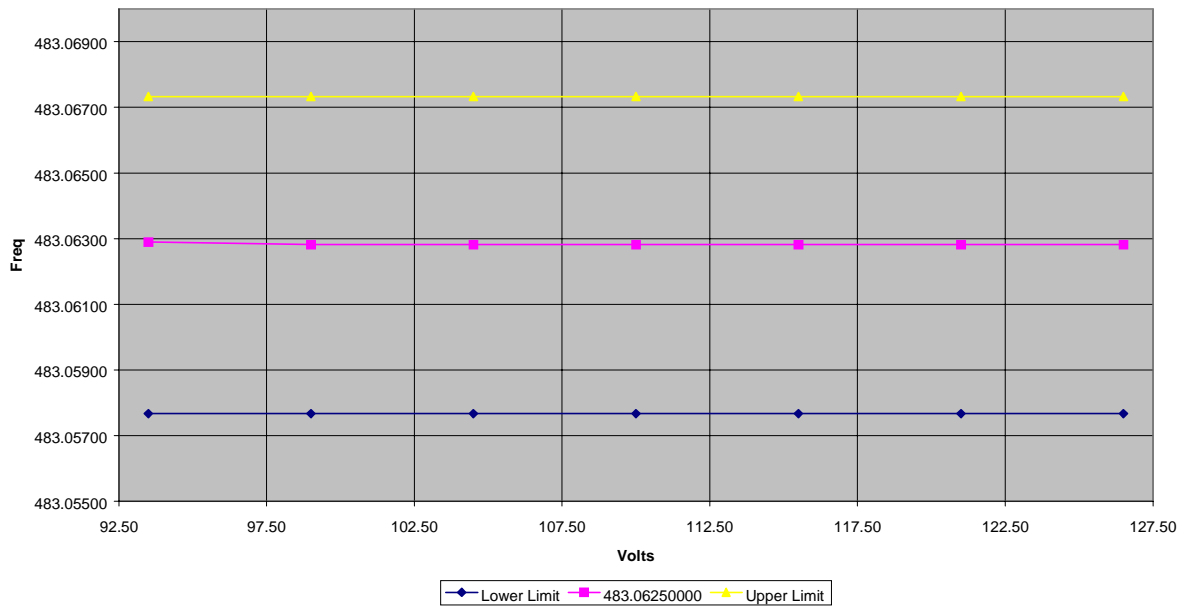

Downlink - 60-055902 - 483.2875MHz Frequency Stability - Voltage

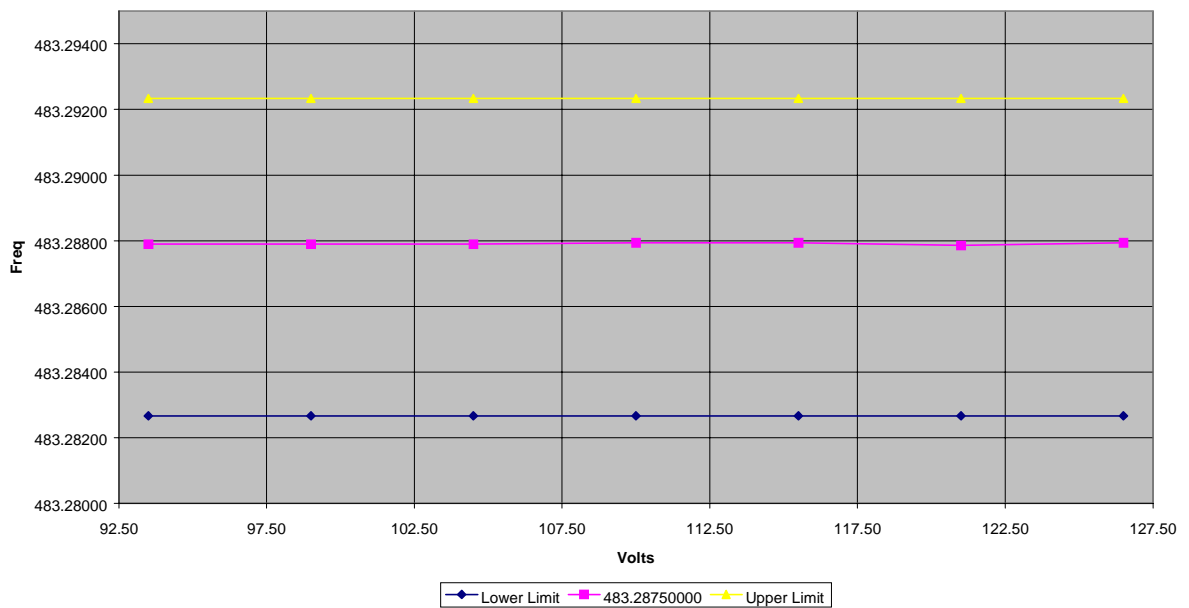

Downlink - 60-055902 - 483.5625MHz Frequency Stability - Voltage

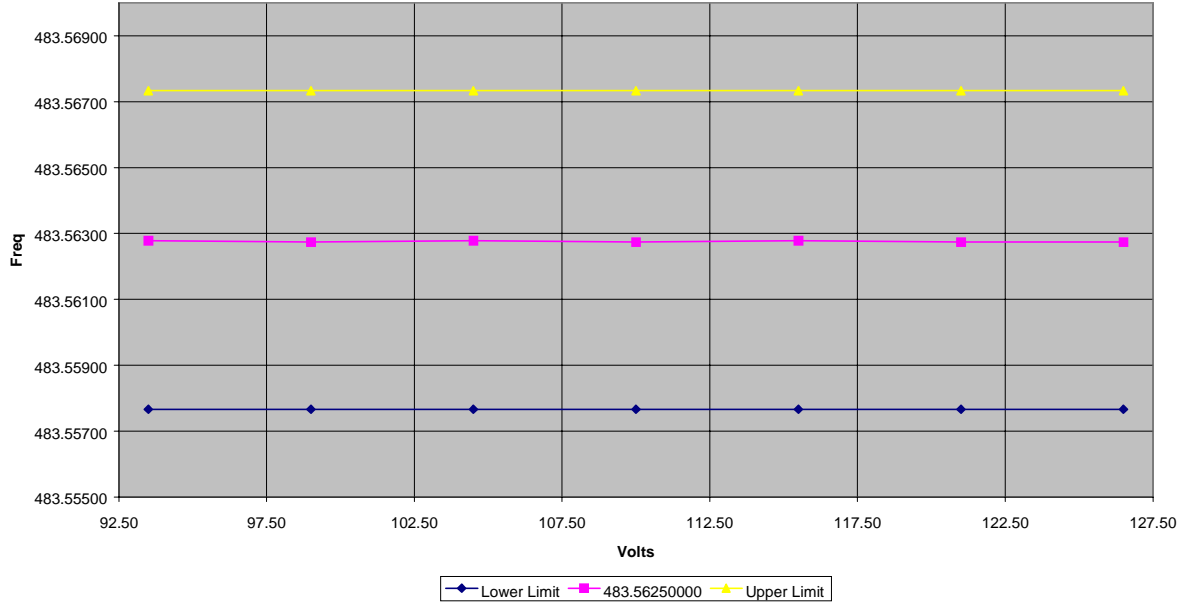

Test equipment used for frequency stability testing:

TYPE OF EQUIPMENT	MAKER/SUPPLIER	MODEL No	SERIAL No	TRL No	ACTUAL EQUIPMENT USED
SPECTRUM ANALYSER	ANRITSU	MS2665C	MT26089	479	X
VARIABLE TRANSFORMER	RS COMPONENTS	8A	207-914	UH34	X
ATTENUATOR	BIRD	8304-300-N	N/A	220	X
ATTENUATOR	BIRD	8308-100	N/A	112	X
CABLE	ROSENBERGER	MICRO COAX	N/A	280	X
SIGNAL GENERATOR	MARCONI	2023	112224/040	UH105	X

TRANSMITTER TESTS

FIBRE OPTIC SYSTEM FREQUENCY STABILITY – TEMPERATURE – Part 90.213– UPLINK

Ambient temperature = N/A
 Relative humidity = N/A
 Conditions = OATS
 Supply voltage = 110Vac

Radio Laboratory
 Test Signal = F3E

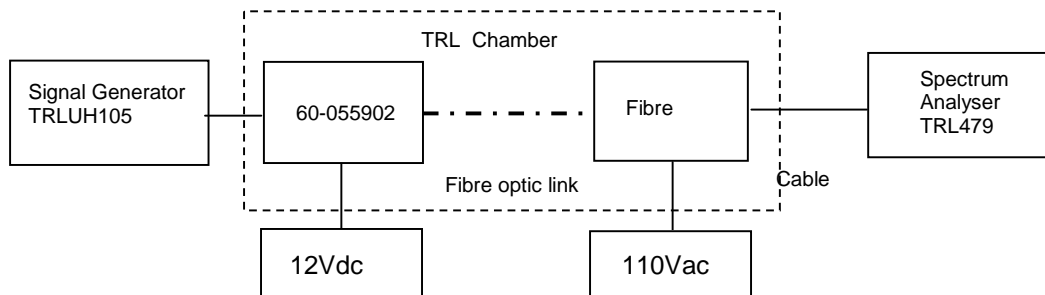

The test was set up as per the diagram. The level at the input was set to -82 dBm. The units were tested operating maximum power on the frequencies as per the table below. Both units were held constant at their nominal operating voltages, 110V. The units were then tested with the ambient temperature varied over the range -30°C to +60°C. The results can be seen in the table below and on the plots over leaf. For reference the frequency variations are compared to a 2.5ppm limit in the plots.

TEMP °C	FREQUENCY 483.0625MHz	PPM	FREQUENCY 483.2875MHz	PPM	FREQUENCY 483.5625MHz	PPM
-30	483.06305MHz	1.139	483.28807MHz	1.179	483.56250MHz	0
-20	483.06283MHz	0.683	483.28783MHz	0.683	483.56183MHz	1.39
-10	483.06320MHz	1.449	483.28800MHz	1.035	483.56250MHz	0
0	483.06300MHz	1.035	483.28800MHz	1.035	483.56300MHz	1.03
10	483.06280MHz	0.621	483.28800MHz	1.035	483.56250MHz	0
20	483.06250MHz	0	483.28780MHz	0.621	483.56280MHz	0.62
30	483.06320MHz	1.449	483.28750MHz	0	483.56280 MHz	0.62
40	483.06280MHz	0.621	483.28780MHz	0.621	483.56250MHz	0
50	483.06280MHz	0.621	483.28880MHz	0.621	483.56240MHz	0.207
60	483.06250MHz	0	483.28800MHz	1.034	483.56230MHz	0.413

Downlink - 483.0625MHz Frequency Stability - Temperature

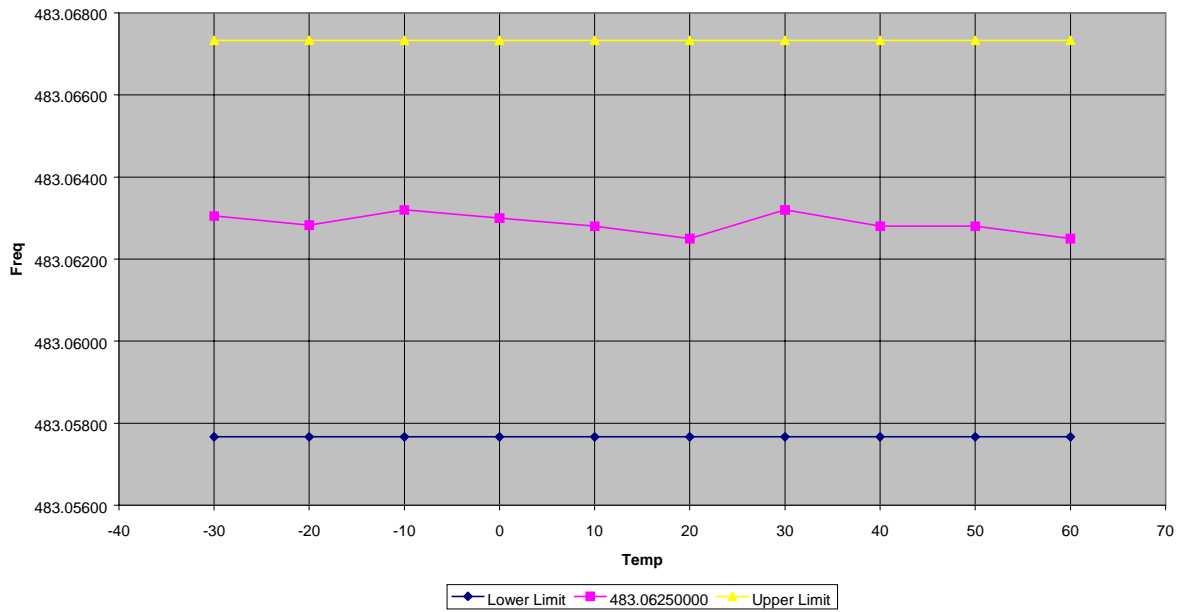

Downlink - 483.2875MHz Frequency Stability - Temperature

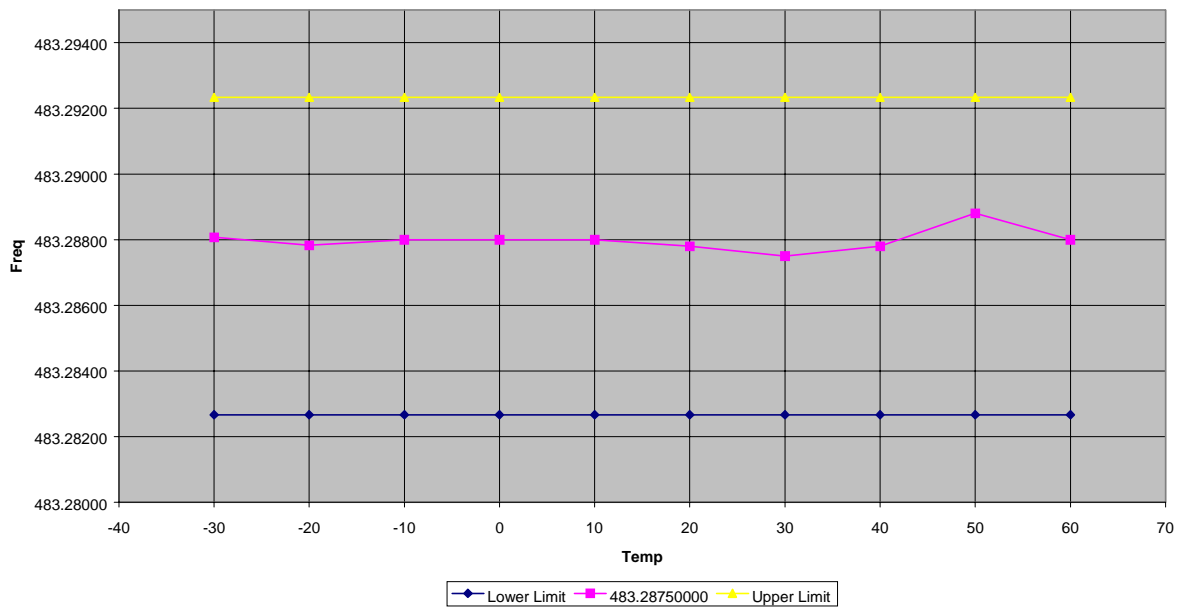

Downlink - 483.5625MHz Frequency Stability - Temperature

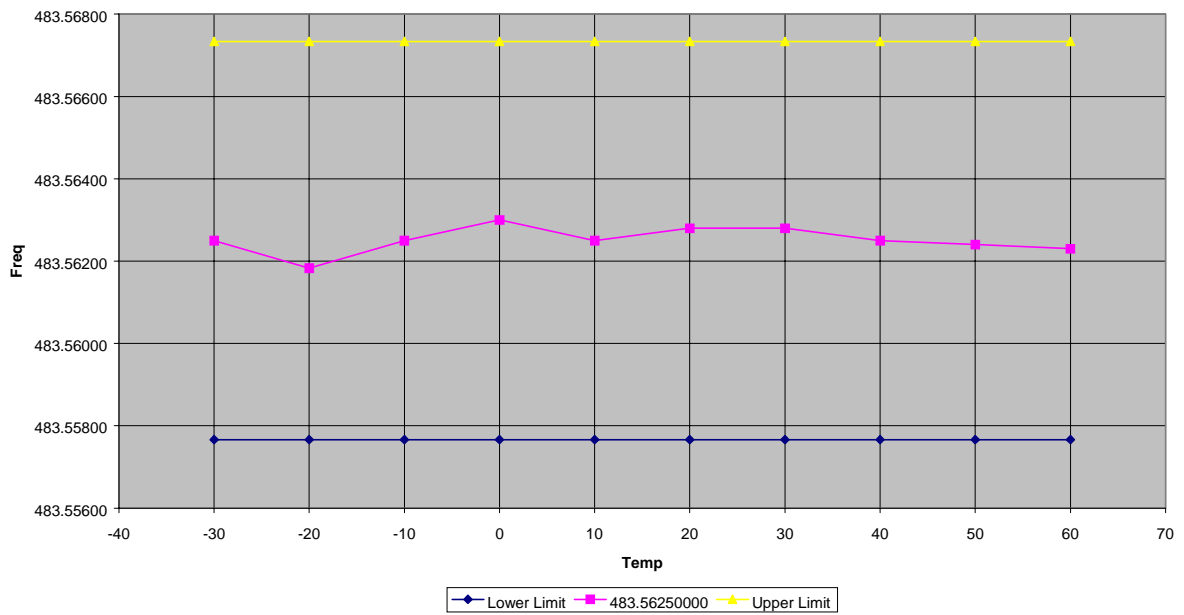

Test equipment used for frequency stability testing:

TYPE OF EQUIPMENT	MAKER/SUPPLIER	MODEL No	SERIAL No	TRL No	ACTUAL EQUIPMENT USED
SPECTRUM ANALYSER	ANRITSU	MS2665C	MT26089	479	X
TEMPERATURE CHAMBER	SHARETREE	TTC 125-815P	CS203	11	X
ATTENUATOR	BIRD	8304-300-N	N/A	220	X
ATTENUATOR	BIRD	8308-100	N/A	112	X
CABLE	ROSENBERGER	MICRO COAX	N/A	280	X
SIGNAL GENERATOR	MARCONI	2023	112224/040	UH105	X

TRANSMITTER TESTS

FIBRE OPTIC SYSTEM TRANSIENT FREQUENCY BEHAVIOUR – Part 90.214 – UPLINK

Ambient temperature	= 21°C	Radio Laboratory
Relative humidity	= 38%	Test Signal = F3E
Conditions	= OATS	
Supply voltage	= 60-137603 + 110Vac	
	= 60-137703 + 12Vdc	

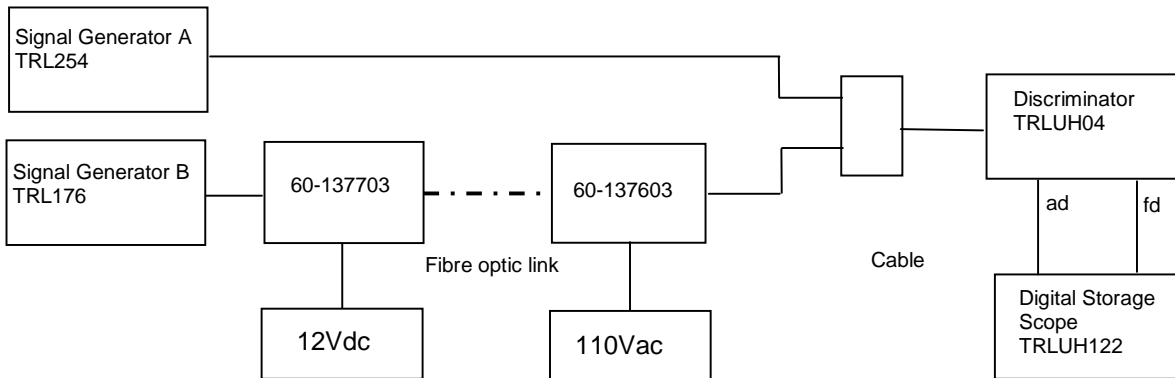

The test equipment was connected as above. Signal generator A was tuned to the centre frequency of the channel selected on the EUT. The signal was modulated with a 1 kHz tone with an FM deviation that corresponds to the EUT operational channel spacing. The power level of the signal is adjusted to 0.1% of the power of the transmitter under test. Signal Generator B was used to mimic the switching on of a transmitter into the EUT.

Both signals were fed into the input of an RF discriminator via a combiner. The discriminator was connected to two channels of the digital storage oscilloscope (DSO). One channel monitored the frequency difference (fd) and the second monitored the audio difference (ad). The DSO is set to display the channel corresponding to the fd input up to ± 1 channel frequency difference. The DSO is set to 10ms/div and to trigger at 1 div from the left edge of the display.

The display will show the 1 kHz test signal continuously. The DSO is then set to trigger on the ad input at a low input rising. The transmitter is then turned on without modulation. Due to the ratio between the 1 kHz test signal and the wanted signal the test signal will be suppressed. The resulting plots were recorded and compared to the limit. See overleaf for plot data.

Time intervals ^{1,2}	Maximum Frequency Difference ³	All Equipment	
		150 to 174 MHz	421 to 512 MHz
Transient Frequency Behaviour for Equipment Designed to operate on 25 kHz Channels			
t_1^4	± 25.0 kHz	5.0 ms	10.0 ms
t_2^4	± 12.5 kHz	20.0 ms	25.0 ms
t_3^4	± 25.0 kHz	5.0 ms	10.0 ms
Transient Frequency Behaviour for Equipment Designed to operate on 12.5 kHz Channels			
t_1^4	± 12.5 kHz	5.0 ms	10.0 ms
t_2^4	± 6.25 kHz	20.0 ms	25.0 ms
t_3^4	± 12.5 kHz	5.0 ms	10.0 ms
Notes	t_{on} is the instant when a 1 kHz test signal is completely suppressed, including any capture time due to phasing. t_1 is the time period immediately following t_{on} t_2 is the time period immediately following t_1 t_3 is the time period from when the transmitter is turned off until t_{off} t_{off} is the instant when the 1 kHz test signal starts to rise		

Frequency of operation = 483.0625MHz

Channel Spacing = 12.5 kHz

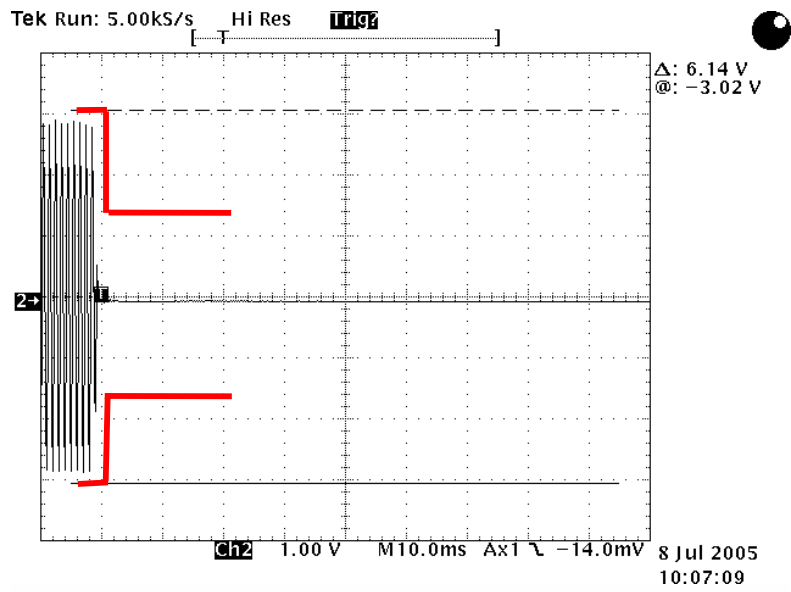

Ton

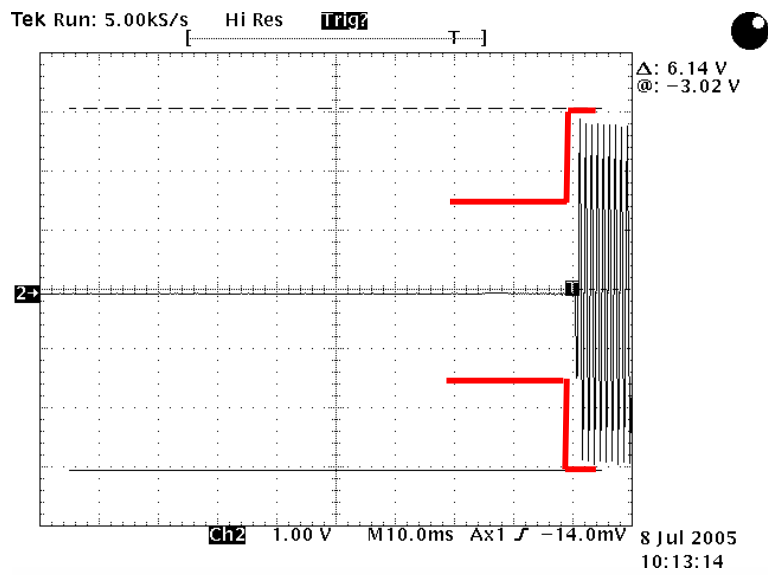

Toff

Frequency of operation = 483.2875MHz

Channel Spacing = 12.5 kHz

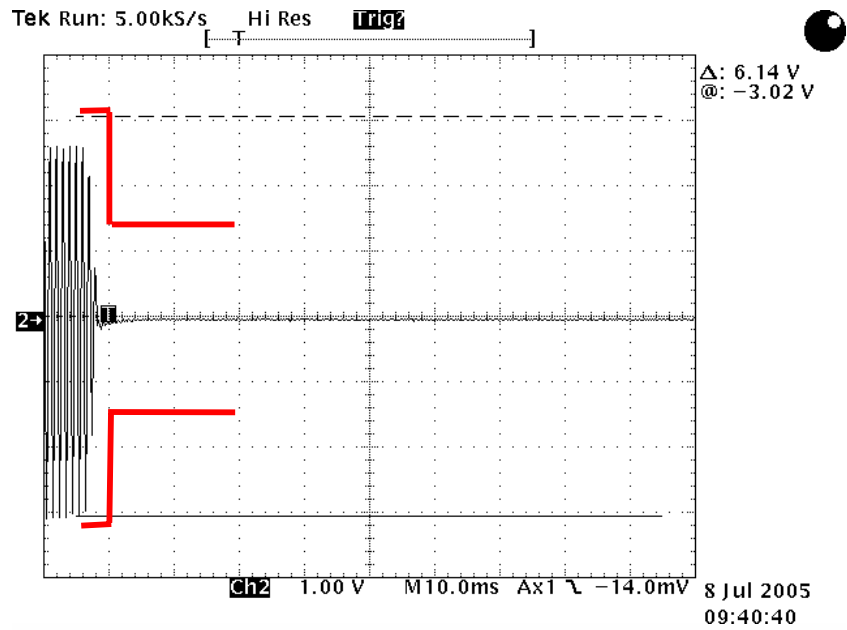

Ton

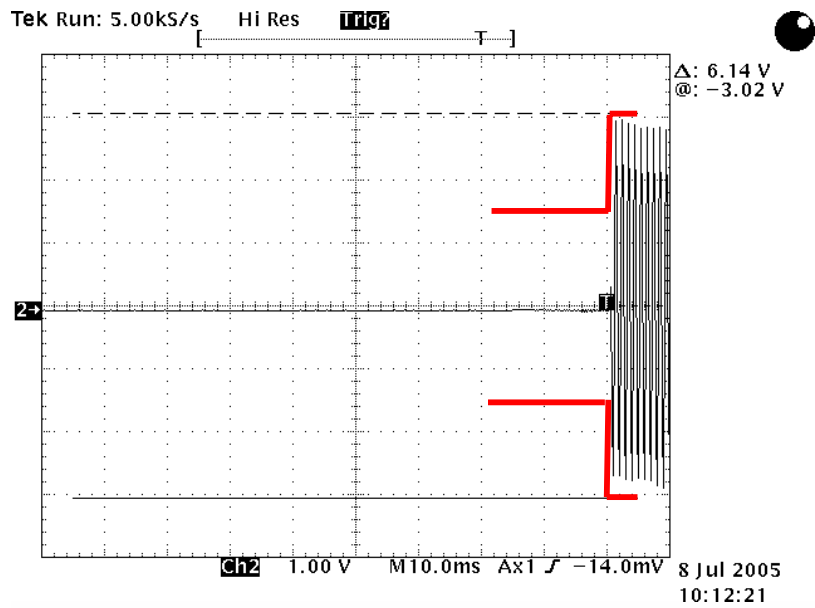

Toff

Frequency of operation = 483.5625 MHz

Channel Spacing = 12.5 kHz

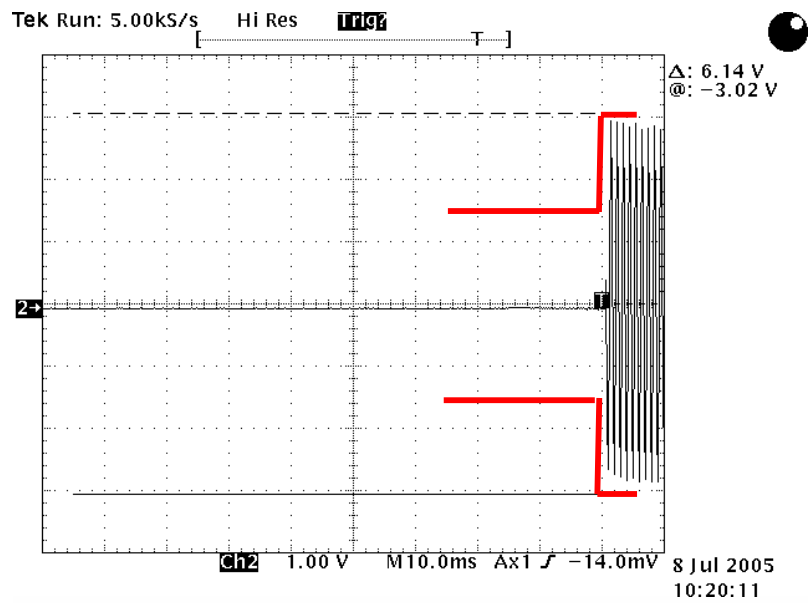
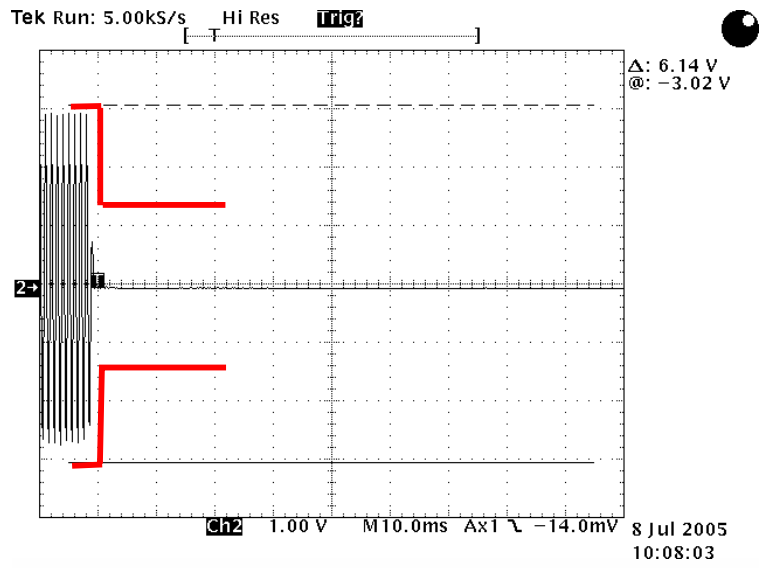

Test equipment used for frequency stability testing:

TYPE OF EQUIPMENT	MAKER/SUPPLIER	MODEL No	SERIAL No	TRL No	ACTUAL EQUIPMENT USED
SPECTRUM ANALYSER	ANRITSU	MS2665C	MT26089	479	X
RECEIVER	RHODE & SCHWARZ	ESVS10	825892/003	UH04	x
ATTENUATOR	BIRD	8304-300-N	N/A	220	X
ATTENUATOR	BIRD	8308-100	N/A	112	X
CABLE	ROSENBERGER	MICRO COAX	N/A	280	X
SIGNAL GENERATOR	MARCONI	2023	112224/040	UH105	X

ANNEX A
PHOTOGRAPHS

PHOTOGRAPH No. 1

TEST SETUP



PHOTOGRAPH No. 2

TEST SETUP



ANNEX B
TEST EQUIPMENT CALIBRATION DETAILS

TEST EQUIPMENT CALIBRATION DETAILS

TRL Number	Equipment Type	Manufacturer	Last Cal Calibration	Calibration Period
	3m Range ERP			
UH006	CAL	TRL	01/03/05	12
UH028	Log Periodic Ant	Schwarbeck	28/04/05	24
UH029	Bicone Antenna	Schwarbeck	27/04/05	24
UH041	Multimeter	AVOmeter	14/12/04	12
UH120	Spectrum Analyser	Marconi	15/03/05	12
UH122	Oscilloscope	Tektronix	07/06/05	24
UH162	ERP Cable Cal	TRL	23/05/05	12
UH179	Power Sensor	Marconi	14/12/04	12
UH228	Power Sensor	Marconi	17/01/05	12
UH253	1m Cable N type	TRL	10/01/05	12
UH254	1m Cable N type	TRL	10/01/05	12
L005	CMTA	R&S	22/10/04	12
L007	Loop Antenna	R&S	29/03/05	24
L138	1-18GHz Horn	EMCO	15/04/05	24
L139	1-18GHz Horn	EMCO	03/05/05	24
L176	Signal Generator	Marconi	31/01/05	12
L193	Bicone Antenna	Chase	12/10/03	24
L203	Log Periodic Ant	Chase	21/10/03	24
L254	Signal Generator	Marconi	13/12/04	12
L280	18GHz Cable	Rosenberger	10/01/05	12
L343	CCIR Noise Filter	TRL	07/06/05	12
	Temperature			
L426	Indicator	Fluke	14/12/04	12
L478	Signal Generator	R&S	19/05/04	12
L479	Analyser	Anritsu	05/10/04	12
L552	Signal Generator	Agilent	25/04/05	12