



TRL Compliance
part of TRAC global

**REPORT ON THE CERTIFICATION TESTING OF A
AXELL WIRELESS
Q115525
WITH RESPECT TO
THE FCC RULES CFR 47, PART 90 Subpart I
PRIVATE LAND MOBILE REPEATER.**



TEST REPORT NO: RU1429/8444
COPY NO: 2
ISSUE NO: 1
FCC ID: NEO80-330555

**REPORT ON THE CERTIFICATION TESTING OF A
AXELL WIRELESS
Q115525
WITH RESPECT TO
THE FCC RULES CFR 47, PART 90 Subpart I
PRIVATE LAND MOBILE REPEATER.**

TEST DATE: 18th – 21st February 2008

TESTED BY: _____ D WINSTANLEY

APPROVED BY: _____ J CHARTERS
RADIO SECTION
LEADER

DATE: 11th July 2008 _____

Distribution:

- Copy Nos:
1. Axell Wireless
 2. TCB: TRL Compliance Limited
 3. TRL Compliance Ltd

THIS DOCUMENT MAY BE REPRODUCED ONLY IN ITS ENTIRETY AND WITHOUT CHANGE

CONTENTS

	PAGE		
CERTIFICATE OF CONFORMITY & COMPLIANCE	4		
APPLICANT'S SUMMARY	5		
EQUIPMENT TEST CONDITIONS	6		
TESTS REQUIRED	6		
TEST RESULTS	7 – 48		
		ANNEX	
PHOTOGRAPHS		A	
PHOTOGRAPH No. 1: Test setup			
PHOTOGRAPH No. 2: Test setup			
APPLICANT'S SUBMISSION OF DOCUMENTATION LIST		B	
EQUIPMENT CALIBRATION		C	
MEASUREMENT UNCERTAINTY		D	
 Notes:			
1.	Component failure during test	YES	<input type="checkbox"/>
		NO	<input checked="" type="checkbox"/>
2.	If Yes, details of failure:		
3.	The facilities used for the testing of the product contain in this report are FCC Listed.		



TRL Compliance

part of TRAC global

CERTIFICATE OF CONFORMITY & COMPLIANCE

FCC IDENTITY: NEO80-330555

PURPOSE OF TEST: Certification

TEST SPECIFICATION: FCC RULES CFR 47, Part 90 Subpart I

TEST RESULT: Compliant to Specification

EQUIPMENT UNDER TEST: Q115525

EQUIPMENT TYPE: Private Land Mobile Repeater

MAXIMUM GAIN: Uplink = 38.40 dB
Downlink = 47.83 dB

MAXIMUM INPUT: Uplink = -28.0 dBm
Downlink = -12.0 dBm

MAXIMUM OUTPUT CONDUCTED: Uplink = 10.0 dBm
Downlink = 34.77 dBm

CHANNEL BANDWIDTH: 30kHz

FREQUENCY GENERATION: N/A

MODULATION TYPE: F3E

POWER SOURCE(s): +110Vac

TEST DATE(s): 18th – 21st February 2008

ORDER No(s): 48689

APPLICANT: Axell Wireless

ADDRESS: Aerial House
Asheridge Road
Chesham
Buckinghamshire
HP5 1TU

TESTED BY: _____ D WINSTANLEY

APPROVED BY: _____ J CHARTERS
RADIO SECTION
LEADER

APPLICANT'S SUMMARY

EQUIPMENT UNDER TEST (EUT): Q115525

EQUIPMENT TYPE: Private Land Mobile Repeater

PURPOSE OF TEST: Certification

TEST SPECIFICATION(s): FCC RULES CFR 47, Part 90 Subpart I

TEST RESULT: COMPLIANT Yes
No

APPLICANT'S CATEGORY: MANUFACTURER
IMPORTER
DISTRIBUTOR
TEST HOUSE
AGENT

APPLICANT'S ORDER No(s): 48689

APPLICANT'S CONTACT PERSON(s): Mr Peter Bradfield

E-mail address: peter.bradfield@axellwireless.com

APPLICANT: Axell Wireless

ADDRESS: Aerial House
Asheridge Road
Chesham
Buckinghamshire
HP5 1TU
United Kingdom

TEL: +44 (0)1494 777000

FAX: +44 (0)1494 778456

MANUFACTURER: Axell Wireless

EUT(s) COUNTRY OF ORIGIN: United Kingdom

TEST LABORATORY: TRL Compliance Ltd

UKAS ACCREDITATION No: 0728

TEST DATE(s): 18th – 21st February 2008

TEST REPORT No: RU1429/8444

COMPLIANCE TESTS

AMPLIFIER GAIN – CONDUCTED – PART 2.1046 – UPLINK

Ambient temperature = 14°C
 Relative humidity = 38%
 Supply voltage = +110Vac
 Channel number = See test results

Radio Laboratory

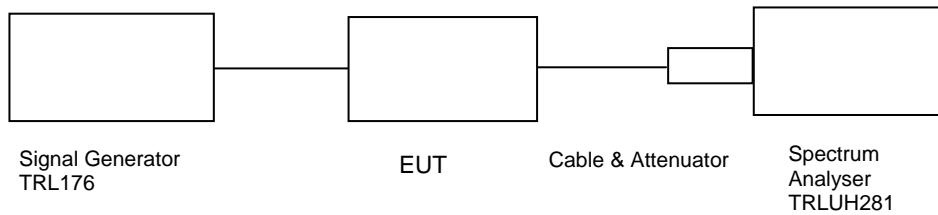

Frequency MHz	Signal Generator input level dBm	Input Cable Loss dB	Output Cable & Attenuator loss dB	Level at Spectrum Analyser dBm	Gain dB	Conducted Output Power dBm	Gain after 10dB input level increase dB
809.0	-27.0	0.4	36.7	-28.6	35.50	8.1	25.5
816.5	-28.0	0.4	36.7	-26.7	38.40	10.0	28.3
824.0	-28.0	0.4	36.7	-28.1	37.00	8.6	27.0

Notes: 1. The signal generator input was increased by 10dBs and the level of the output signal remeasured.

TYPE OF EQUIPMENT	MAKER/SUPPLIER	MODEL No	SERIAL No	TRL No	ACTUAL EQUIPMENT USED
SPECTRUM ANALYSER	RHODE & SCHWARZ	FSU46	200034	UH281	X
ATTENUATOR	BIRD	8304-300-N	N/A	220	X
ATTENUATOR	BIRD	8304-100-N	N/A	222	X
CABLE	TRL	N/A	N/A	UH273	X
CABLE	TRL	N/A	N/A	UH274	X
SIGNAL GENERATOR	MARCONI	2042	119388/080	176	X

AMPLIFIER INTERMODULATION SPURIOUS EMISSIONS – CONDUCTED – PART 2.1053– UPLINK

Ambient temperature = 17°C
 Relative humidity = 36%
 Supply voltage = +110Vac

Radio Laboratory

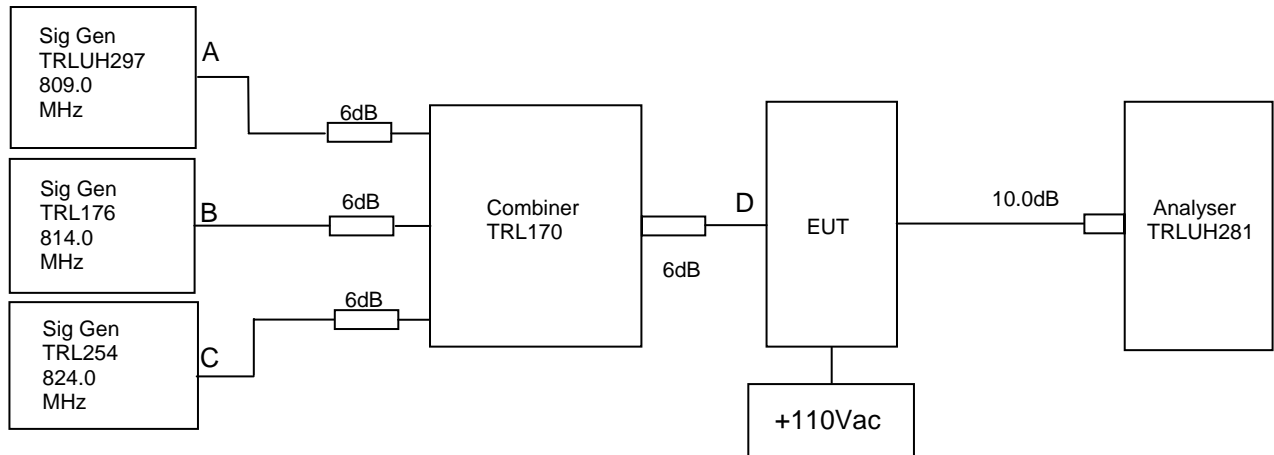

The intermodulation and spurious products were measured with the amplifier operating at maximum gain. A three tone test was conducted using the equipment as above. The input power level was adjusted so the level at point D was 10dB above the maximum input of -27.0dBm. The cable and attenuator loss between the EUT and the spectrum analyser was 10dB.

RF Input Frequency (MHz)			Highest Intermodulation Product Level (dBm)	Limit (dBm)
809.0	814.0	824.0	-24.0 dBm @ 819.0 MHz	-13

Sweep data is shown on the next page:

Test equipment used for intermodulation test

TYPE OF EQUIPMENT	MAKER/SUPPLIER	MODEL No	SERIAL No	TRL No	ACTUAL EQUIPMENT USED
SPECTRUM ANALYSER	ANRITSU	MS2665C	MT26089	479	
SPECTRUM ANALYSER	R&S	FSU46	200034	UH281	X
SIGNAL GENERATOR	MARCONI	2042	119388/080	176	X
SIGNAL GENERATOR	R&S	SML 03	102268	UH297	X
SIGNAL GENERATOR	MARCONI	2042	119562/021	254	X
SIGNAL GENERATOR	HP	83630B	3722A00588	UH340	
CMTA	ROHDE & SCHWARZ	CMTA52	894715/033	05	
COMBINER	ELCOM	RC-4-50	N/A	170	X

Intermodulation Inband

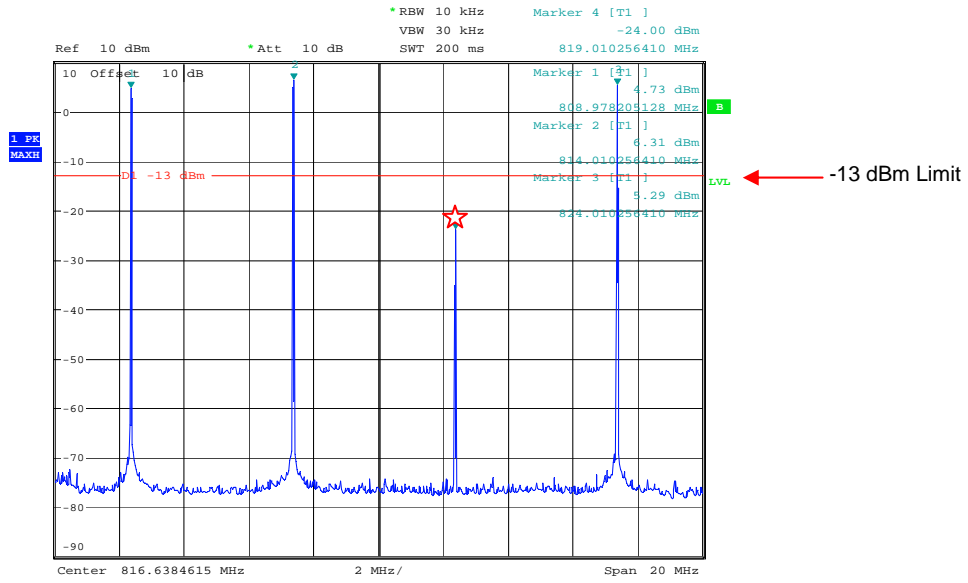

Date: 19.FEB.2008 11:52:17

20MHz Span

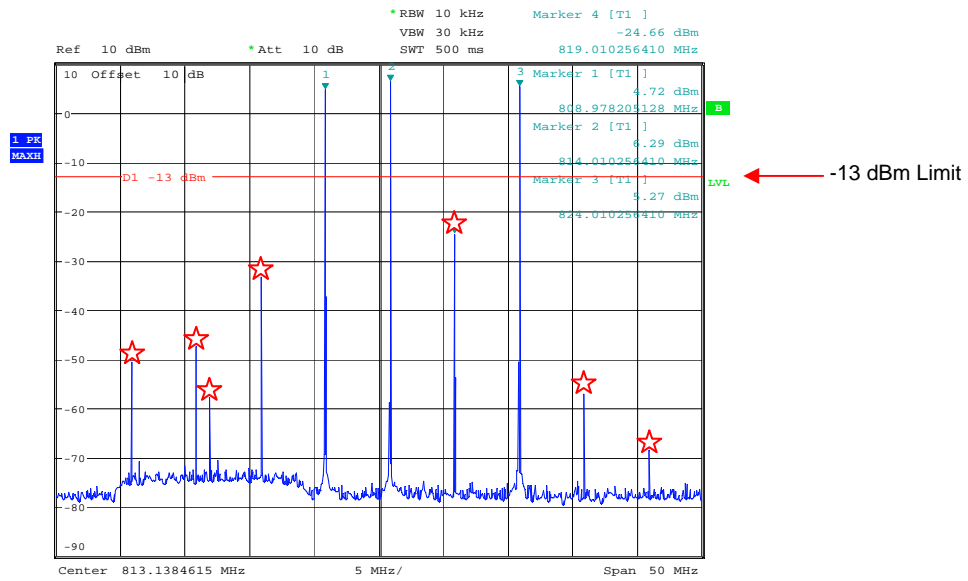

Date: 19.FEB.2008 11:52:39

50MHz Span

The above plots show that all products (designated by ☆) are below the spurious limit.

Intermodulation Wideband

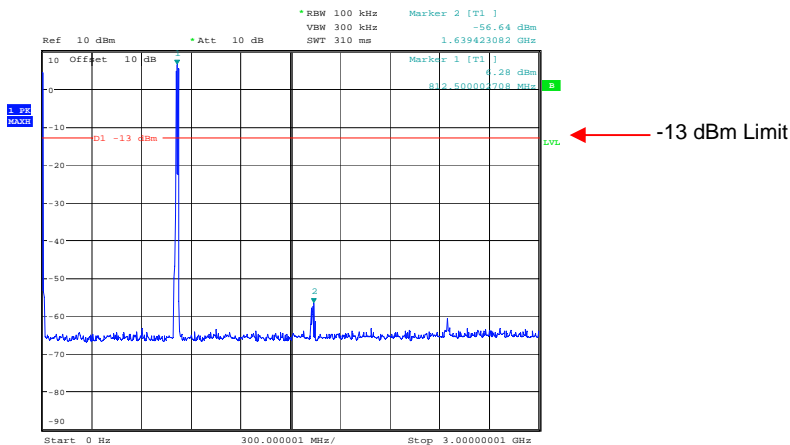

Date: 19.FEB.2008 11:53:14

0Hz – 3GHz

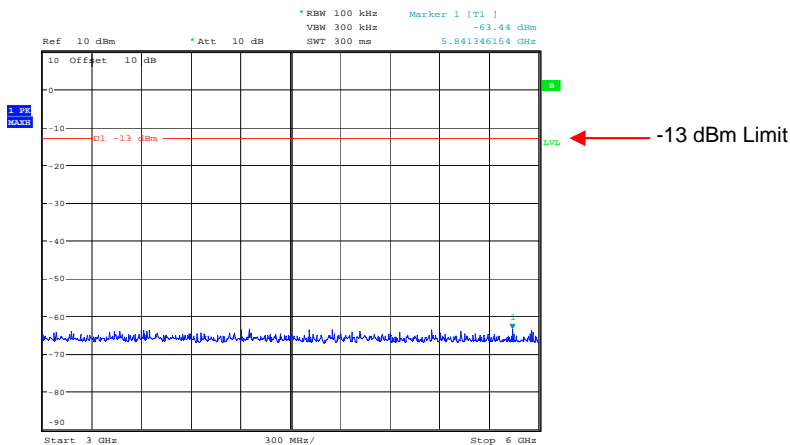

Date: 19.FEB.2008 11:53:30

3GHz – 6GHz

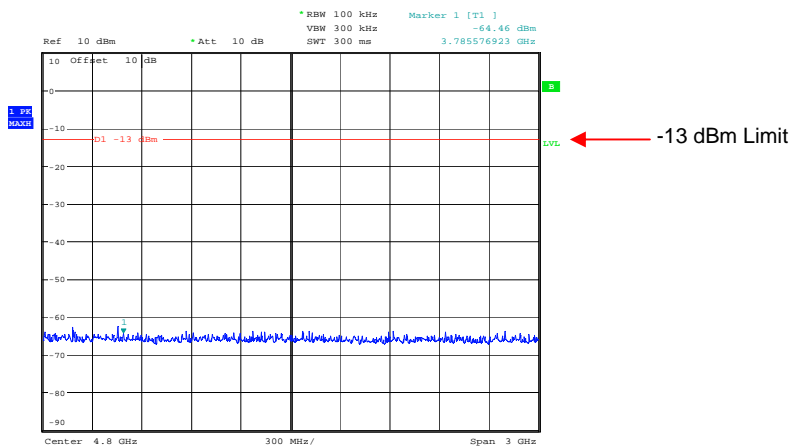

Date: 19.FEB.2008 11:53:44

6GHz – 9GHz

The above plot shows that there are no significant products outside the bands.

TRANSMITTER TESTS

AMPLIFIER MODULATED CHANNEL TEST – CONDUCTED – Part 2.1049– UPLINK

Ambient temperature = 16°C Radio Laboratory
 Relative humidity = 34%
 Supply voltage = +110Vac
 Channel number = See test results

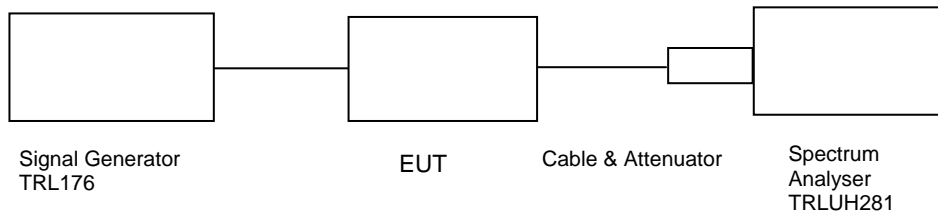

This test was performed to show that the amplifier does not alter the input signal in any way. The input signal was set to the maximum input level (-27dBm) and modulated with a 2500Hz tone. The plots show the signal measured at the signal generator and the signal measured at the output of the EUT.

Note: The cables and attenuators had the following losses.

1. Cable and attenuator between EUT and spectrum analyser 10dB
2. Cable between signal generator and EUT 0.4dB

TYPE OF EQUIPMENT	MAKER/SUPPLIER	MODEL No	SERIAL No	TRL No	ACTUAL EQUIPMENT USED
SPECTRUM ANALYSER	RHODE & SCHWARZ	FSU46	200034	UH281	X
ATTENUATOR	BIRD	8304-300-N	N/A	220	X
CABLE	TRL	N/A	N/A	UH273	X
CABLE	TRL	N/A	N/A	UH274	X
SIGNAL GENERATOR	MARCONI	2042	119388/080	176	X

809.0 MHz Signal Generator, deviation set to 5kHz

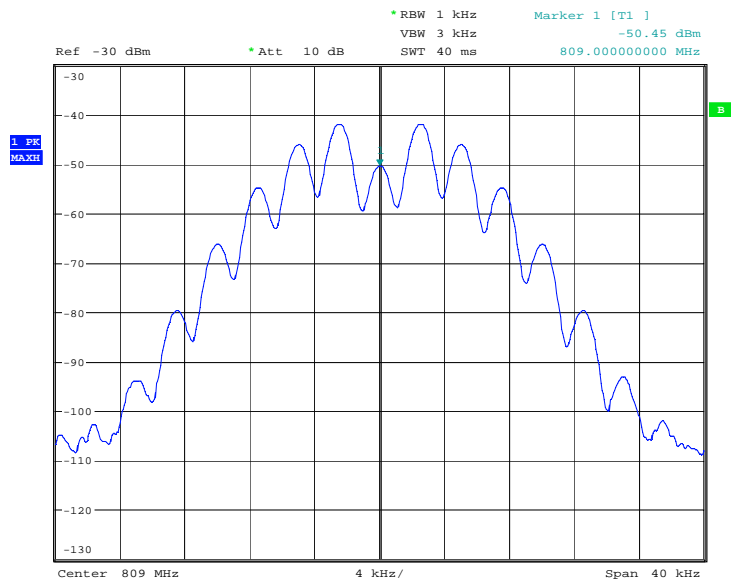

Date: 19.FEB.2008 11:14:13

809.0 MHz Signal Generator and EUT, deviation set to 5kHz

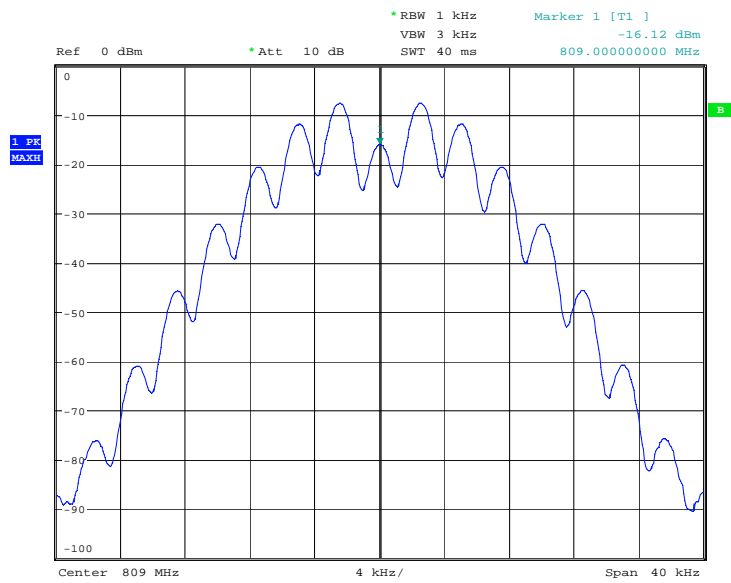

Date: 19.FEB.2008 10:44:47

The above plots depicting the output wavelshape show no measurable distortion visible when compared to the input signal.

816.5 MHz Signal Generator, deviation set to 5kHz

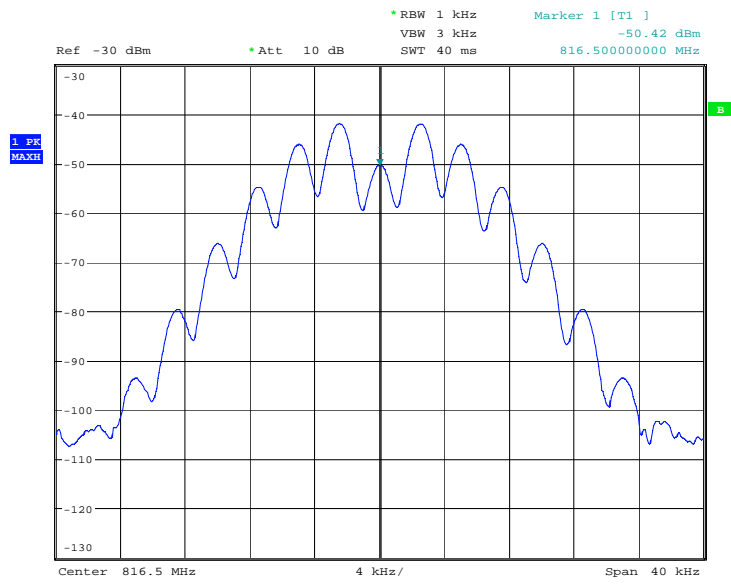

Date: 19.FEB.2008 11:14:30

816.5 MHz Signal Generator and EUT, deviation set to 5kHz

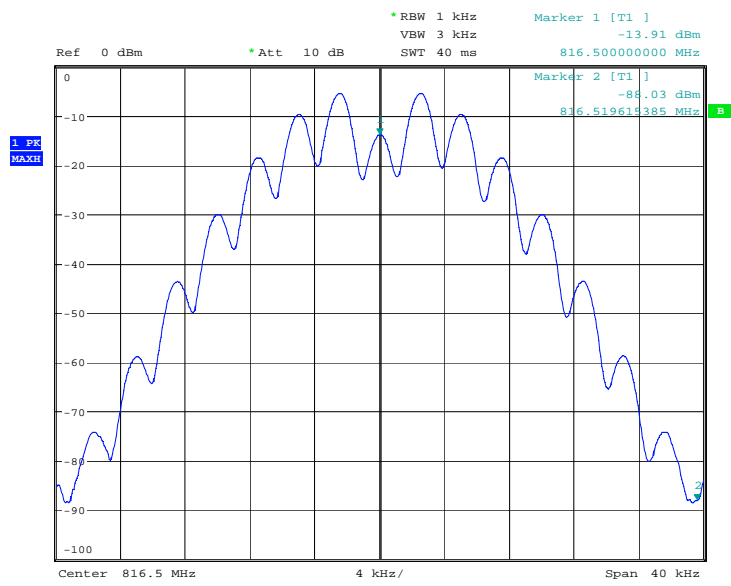

Date: 19.FEB.2008 10:43:39

The above plots depicting the output wavelshape show no measurable distortion visible when compared to the input signal.

824.0 MHz Signal Generator, deviation set to 5kHz

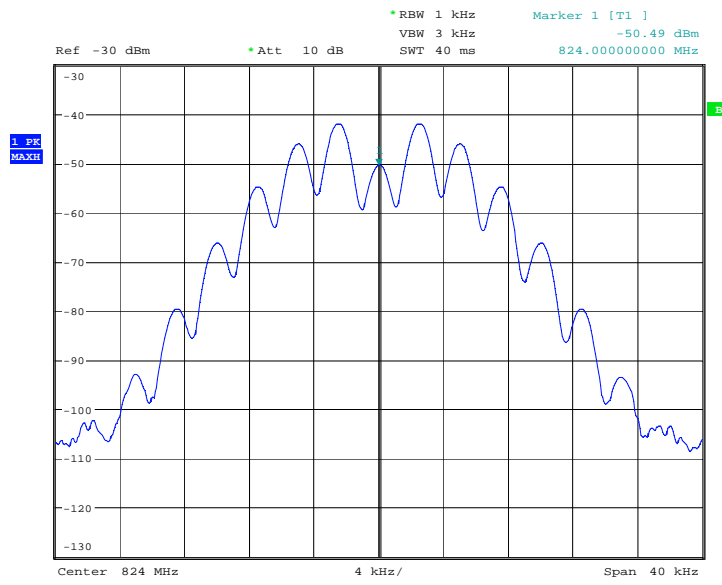

Date: 19.FEB.2008 11:15:25

824.0 MHz Signal Generator and EUT, deviation set to 5kHz

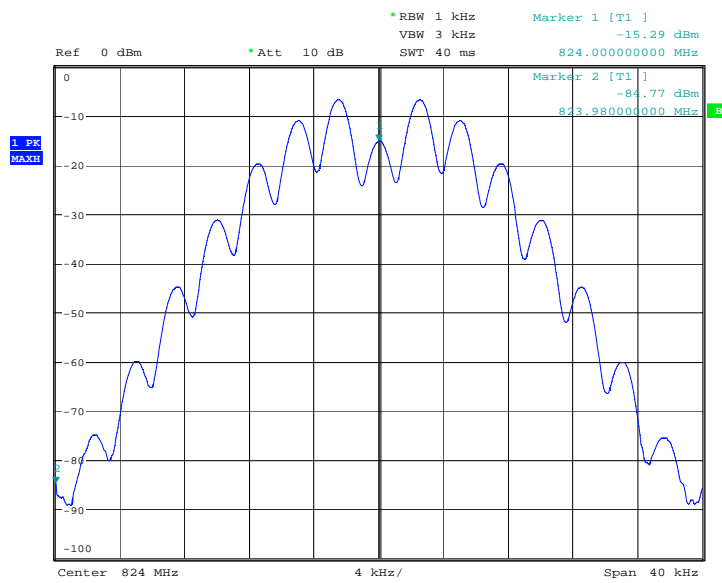

Date: 19.FEB.2008 10:43:57

The above plots depicting the output wavelshape show no measurable distortion visible when compared to the input signal.

TRANSMITTER TESTS

AMPLIFIER SPURIOUS EMISSIONS – CONDUCTED – Part 2.1053 – UPLINK

Ambient temperature = 16°C
 Relative humidity = 34%
 Supply voltage = +110Vac

Radio Laboratory Test Signal = F3E

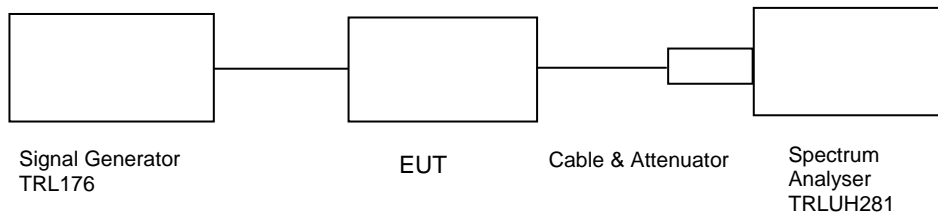

The test was set up as per the diagram. The level at the input was adjusted to compensate for the loss of the interconnecting cable. The unit was tested operating at maximum power and on three test frequencies.

The Spurious limit was calculated as follows:

On any frequency removed from the assigned frequency by more than 250% of the authorised bandwidth

At least $43 + 10 \log P_{dB}$

$$(10 \log P_{\text{watts}}) - (43 + 10 \log (P_{\text{watts}} * 1000)) = \text{LIMIT} = -13 \text{ dBm}$$

RESULTS

FREQUENCY RANGE	FREQ. (MHz)	MEASURED LEVEL (dBm)	ATTENUATOR & CABLE LOSSES (dB)	EMISSION LEVEL (dBm)	LIMIT (dBm)
0Hz – 9 GHz	No Significant Emissions Within 20dB of Limit				-13

The test equipment used for the Transmitter Conducted Emissions:

TYPE OF EQUIPMENT	MAKER/SUPPLIER	MODEL No	SERIAL No	TRL No	ACTUAL EQUIPMENT USED
SPECTRUM ANALYSER	RHODE & SCHWARZ	FSU46	200034	UH281	X
ATTENUATOR	BIRD	8304-300-N	N/A	220	X
CABLE	TRL	N/A	N/A	UH273	X
CABLE	TRL	N/A	N/A	UH274	X
SIGNAL GENERATOR	MARCONI	2042	119388/080	176	X

Conducted emissions 809.0 MHz 0Hz – 3GHz

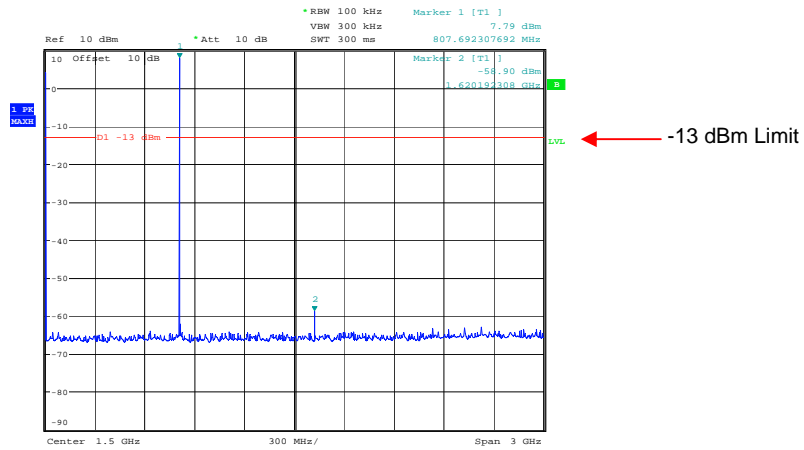

Date: 19.FEB.2008 10:19:45

Conducted emissions 809.0 MHz 3GHz – 6GHz

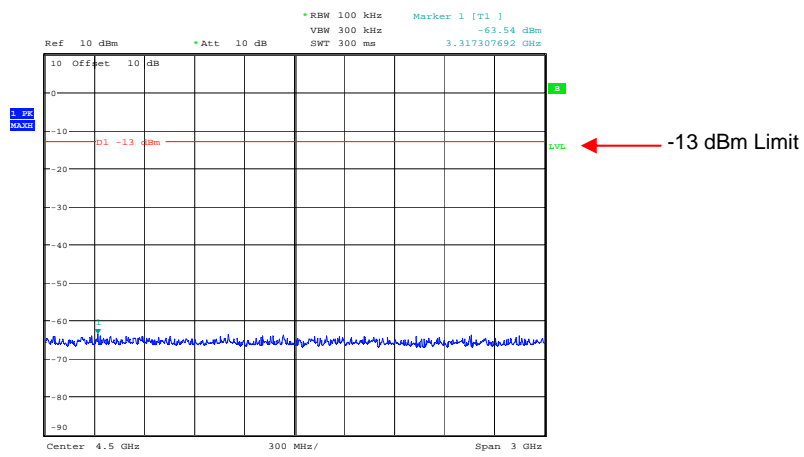

Date: 19.FEB.2008 10:20:14

Conducted emissions 809.0 MHz 6GHz – 9GHz

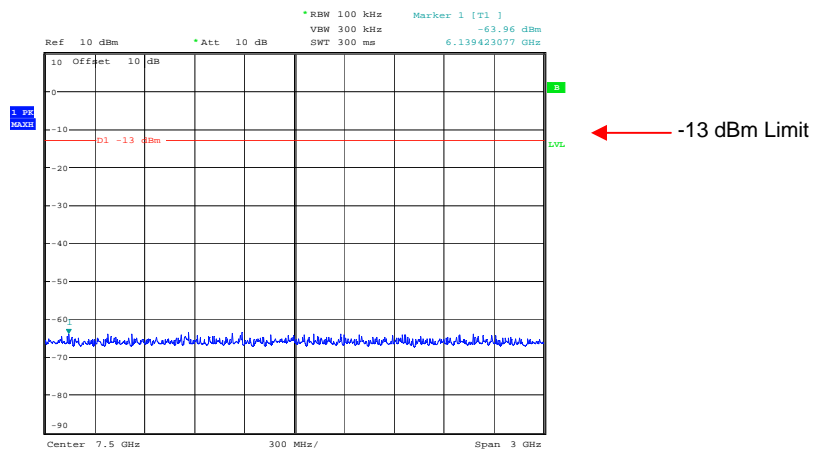

Date: 19.FEB.2008 10:20:26

Conducted emissions 816.5 MHz 0Hz – 3GHz

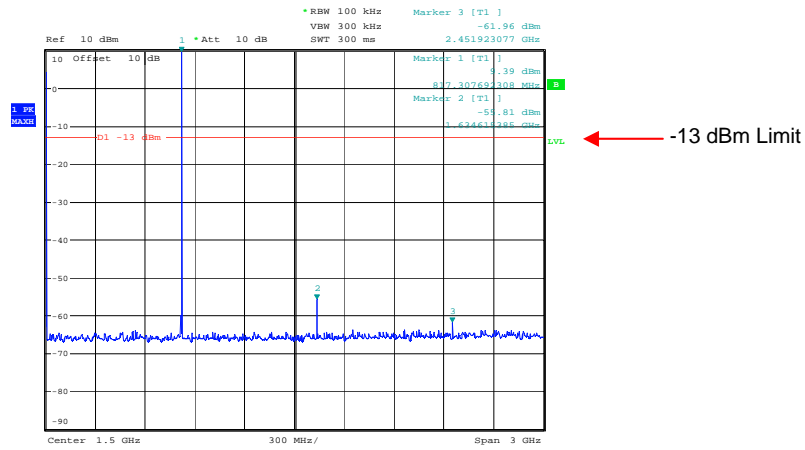

Date: 19.FEB.2008 10:23:26

Conducted emissions 816.5 MHz 3GHz – 6GHz

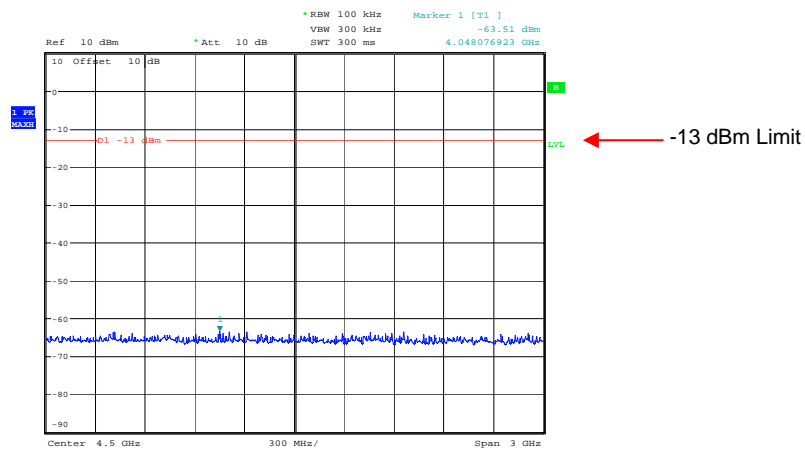

Date: 19.FEB.2008 10:23:06

Conducted emissions 816.5 MHz 6GHz – 9GHz

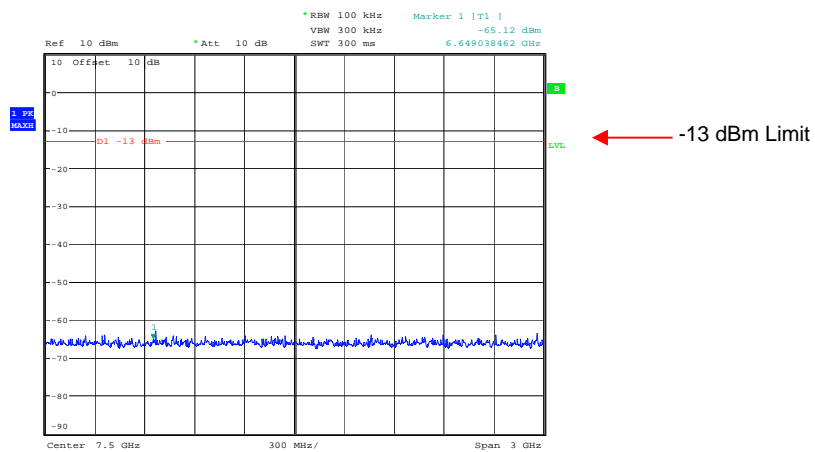

Date: 19.FEB.2008 10:20:55

Conducted emissions 824.0 MHz 0Hz – 3GHz

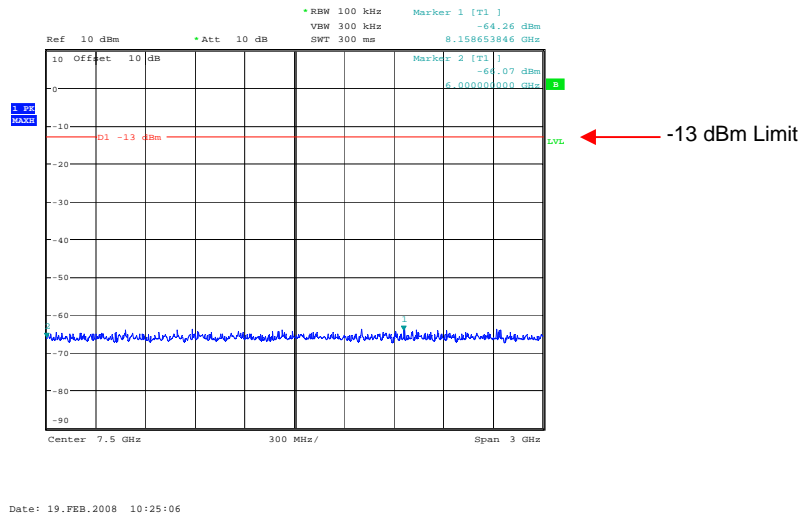

Conducted emissions 824.0 MHz 3GHz – 6GHz

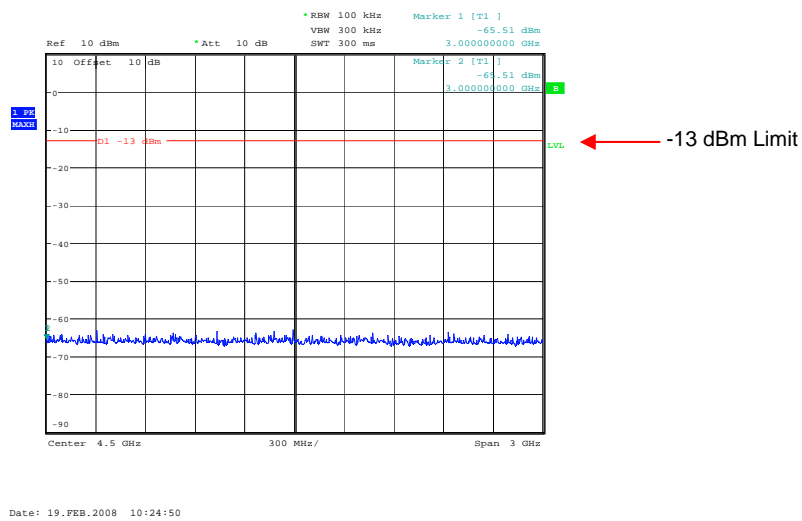

Conducted emissions 824.0 MHz 6GHz – 9GHz

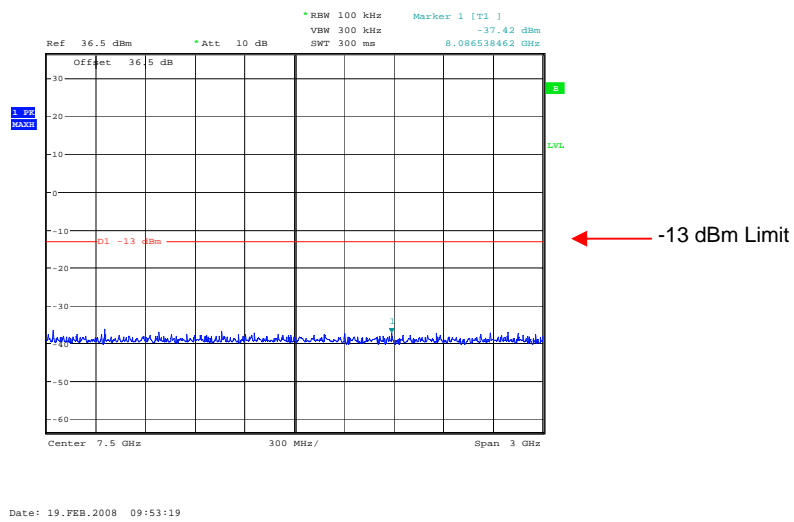

TRANSMITTER TESTS

AMPLIFIER SPURIOUS EMISSIONS – RADIATED – Part 2.1053– UPLINK

Ambient temperature = 14°C
 Relative humidity = 42%
 Conditions = OATS
 Supply voltage = +110Vac
 Supply Frequency = N/A

Test Signal = F3E

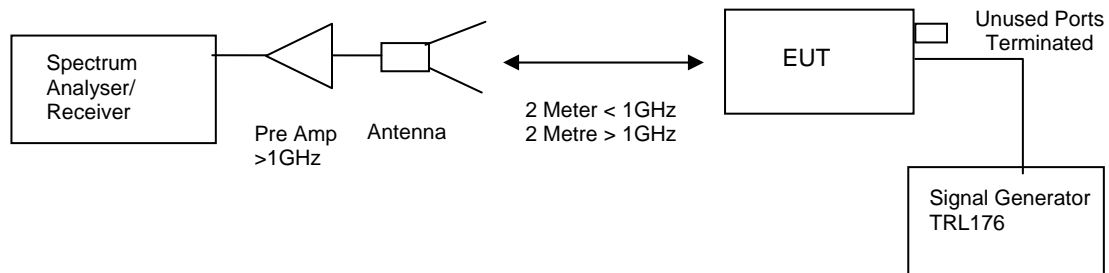

The test was set up as per the diagram. The level at the input was adjusted to compensate for the loss of the interconnecting cable. The unit was tested operating maximum power on three test frequencies with a 50 ohm load on the output. The unit was also tested with the signal generator replaced by another 50ohm load.

The Spurious limit was calculated as follows:

On any frequency removed from the assigned frequency by more that 250% of the authorised bandwidth

At least $43 + 10 \log P_{dB}$

$(10 \log P_{watts}) - (43 + 10 \log (P_{watts} * 1000)) = \text{LIMIT} = -13 \text{ dBm}$

RESULTS

FREQUENCY RANGE	FREQ. (MHz)	MEAS. Rx. (dBµV)	CABLE LOSS (dB)	ANT FACTOR	FIELD STRENGTH (dBµV/m)	CALCULATED EIRP (dBm)	LIMIT (dBm)
0Hz – 9GHz	No Significant Emissions Within 20dB of Limit.						-13

The test equipment used for the Transmitter Spurious Emissions:

TYPE OF EQUIPMENT	MAKER/SUPPLIER	MODEL No	SERIAL No	TRL No	ACTUAL EQUIPMENT USED
HORN	EMCO	3115	9010-3580	138	X
SPECTRUM ANALYSER	R&S	FSU46	200034	UH281	X
PRE AMPLIFIER	HP	8449B	3008A016	572	X
SIGNAL GENERATOR	MARCONI	2042	119388/080	176	X
ANTENNA	YORK	CBL611/A	1618	UH191	X
RECEIVER	R&S	ESVS10	825892/006	UH04	X

Radiated emissions 809.0 MHz 30MHz – 1GHz

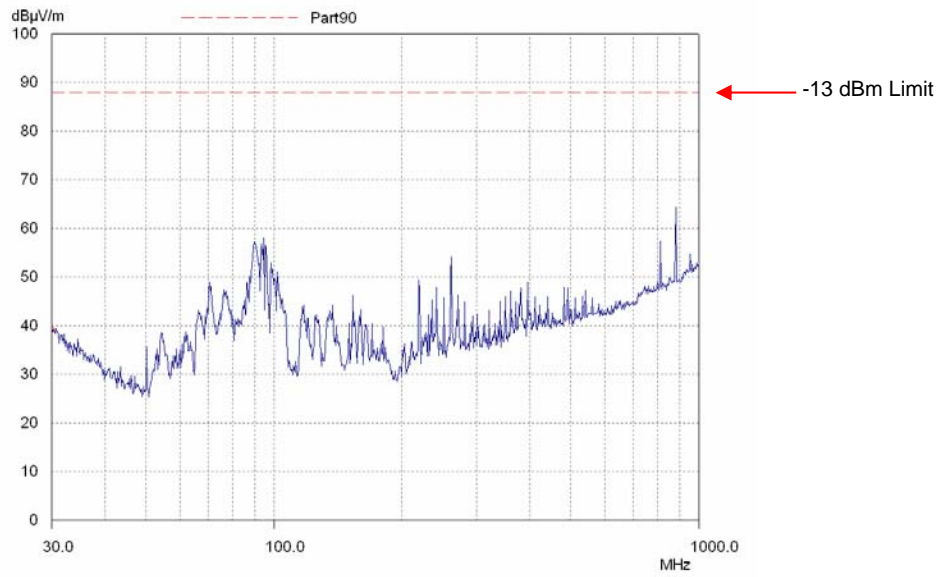

Radiated emissions 809.0 MHz 1GHz – 3GHz

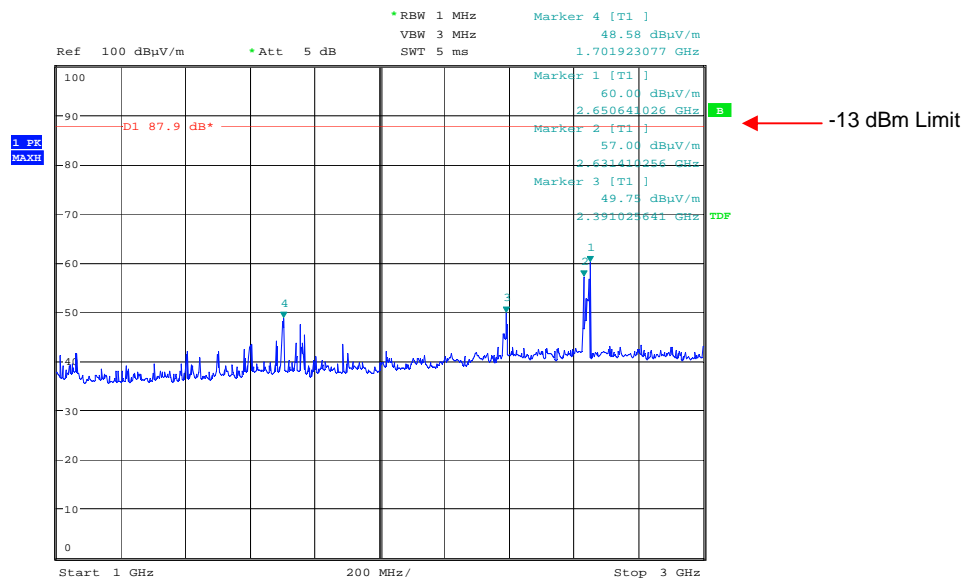

Date: 18.FEB.2008 16:12:24

The above test results show that there were no emissions within 20dBs of the -13dBm limit.

Radiated emissions 809.0 MHz 3GHz – 6GHz

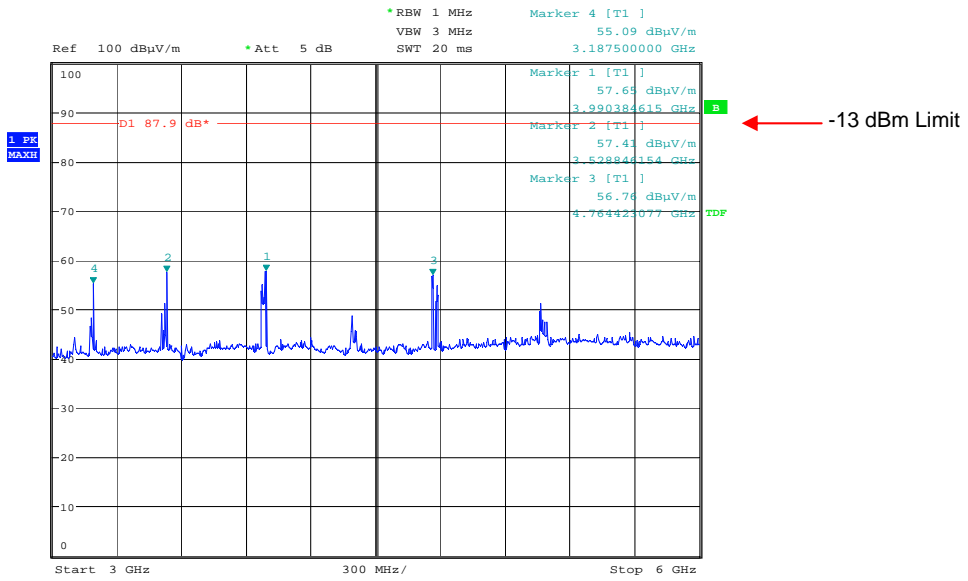

Radiated emissions 809.0 MHz 6GHz – 9GHz

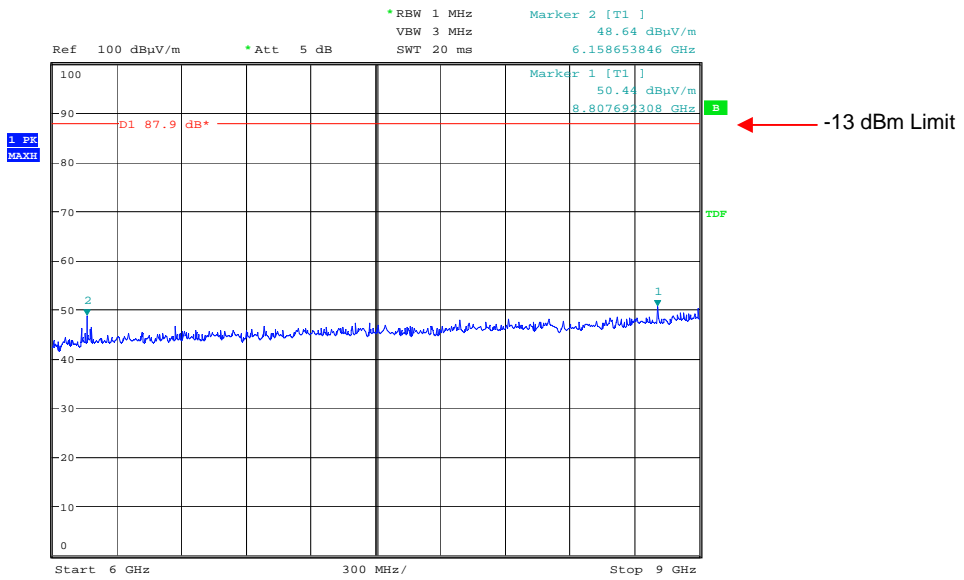

The above test results show that there were no emissions within 20dBs of the -13dBm limit.

Radiated emissions 816.5 MHz 30MHz – 1GHz

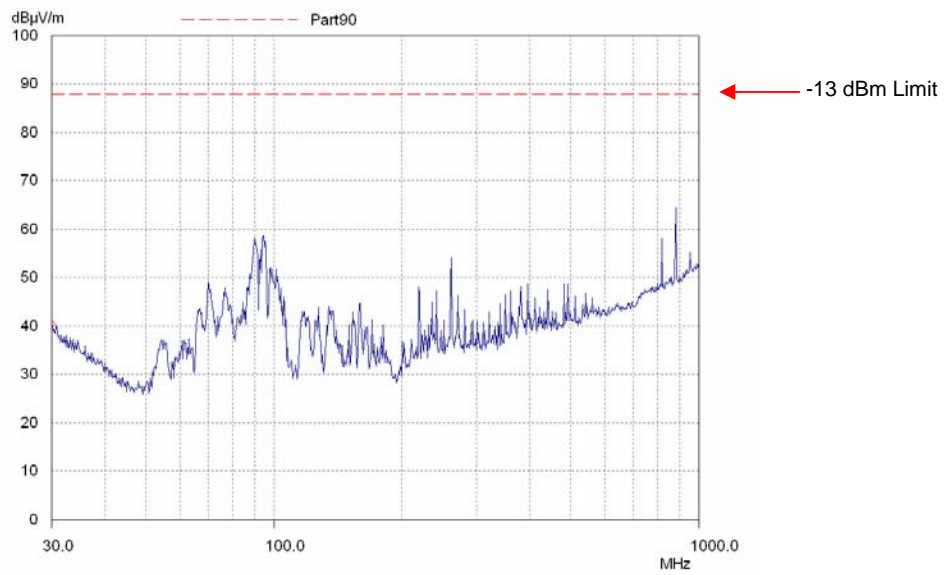

Radiated emissions 816.5 MHz 1GHz – 3GHz

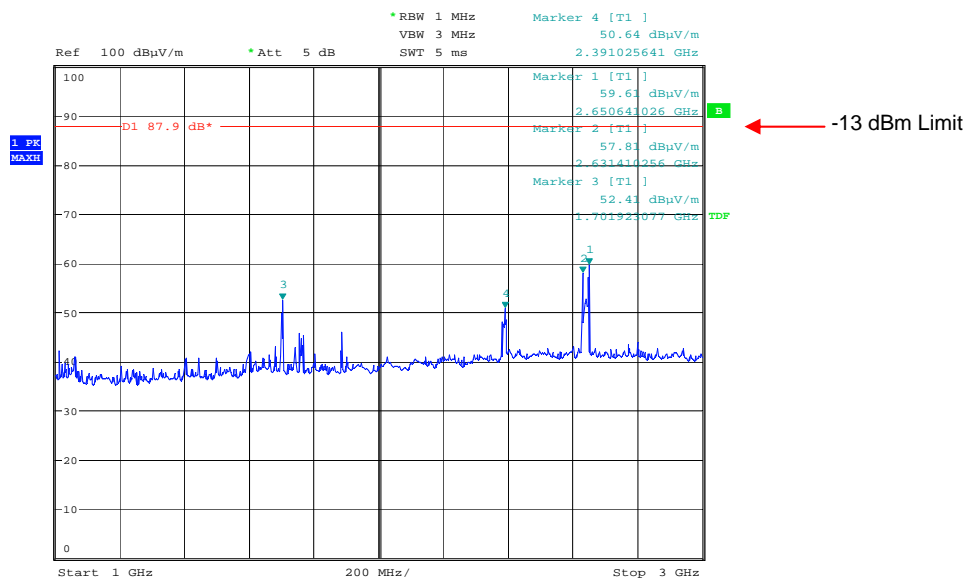

Date: 18.FEB.2008 16:21:59

The above test results show that there were no emissions within 20dBs of the -13dBm limit.

Radiated emissions 816.5 MHz 3GHz – 6GHz

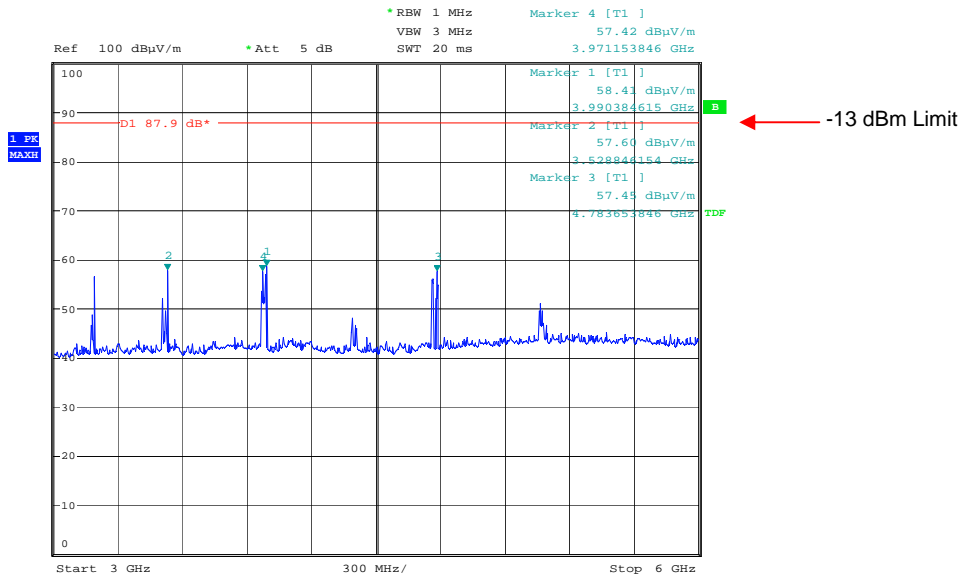

Date: 18.FEB.2008 16:22:47

Radiated emissions 816.5 MHz 6GHz – 9GHz

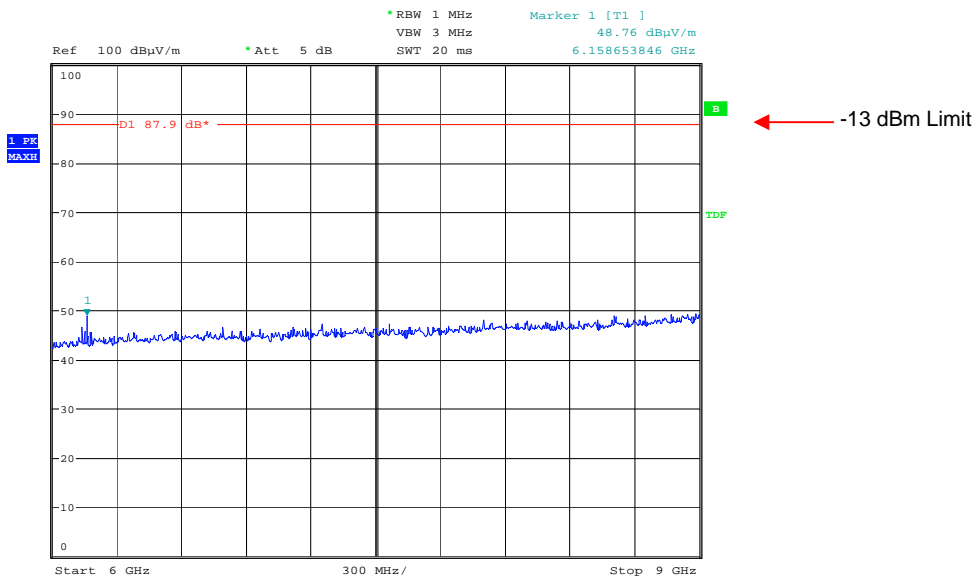

Date: 18.FEB.2008 16:23:38

The above test results show that there were no emissions within 20dBs of the -13dBm limit.

Radiated emissions 824.0 MHz 30MHz – 1GHz

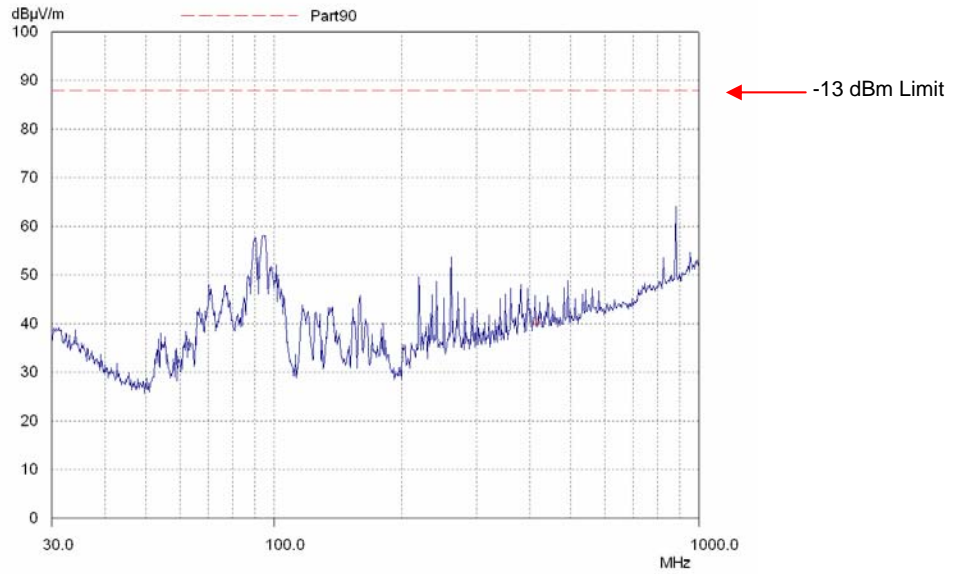

Radiated emissions 824.0 MHz 1GHz – 3GHz

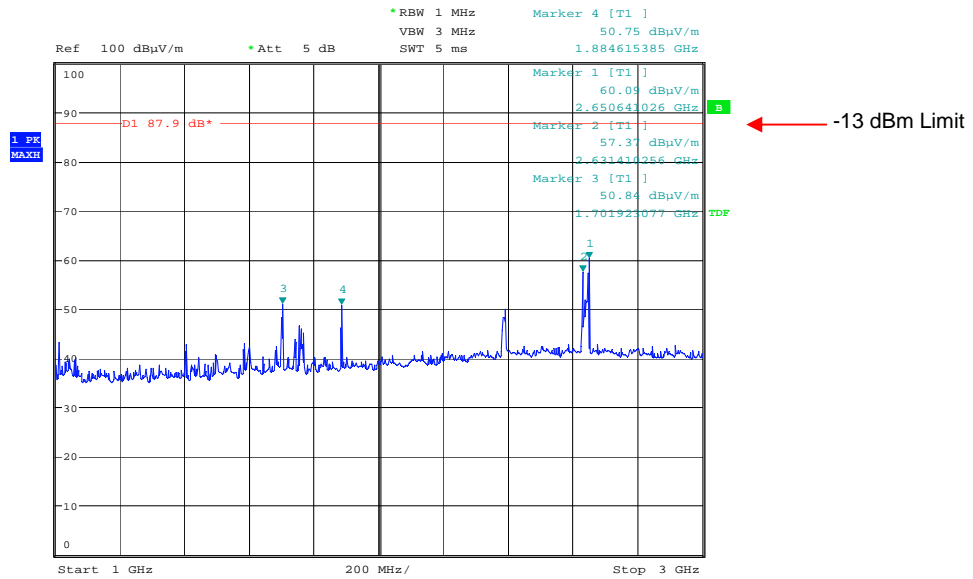

Date: 18.FEB.2008 16:25:18

The above test results show that there were no emissions within 20dBs of the -13dBm limit.

Radiated emissions 824.0 MHz 3GHz – 6GHz

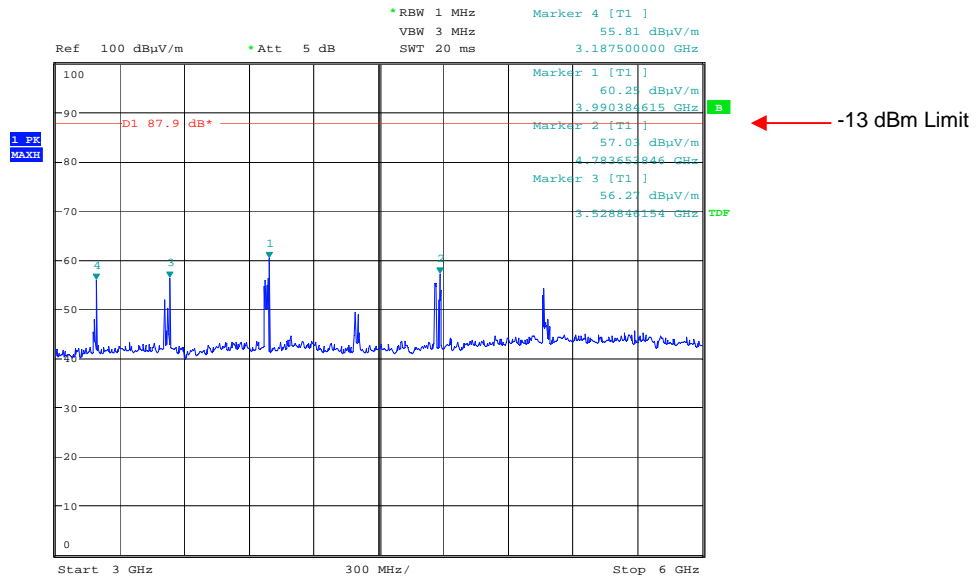

Date: 18.FEB.2008 16:26:16

Radiated emissions 824.0 MHz 6GHz – 9GHz

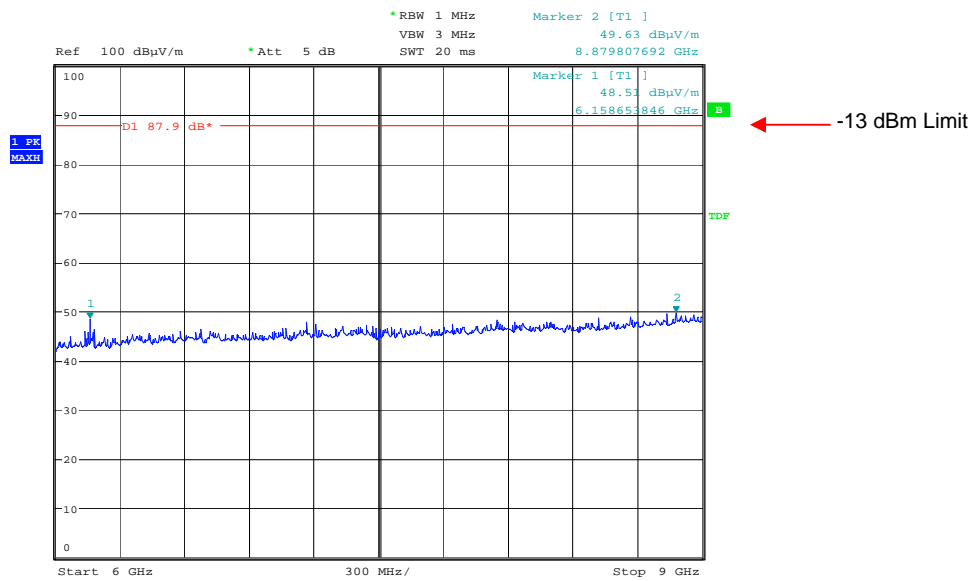

Date: 18.FEB.2008 16:27:10

The above test results show that there were no emissions within 20dBs of the -13dBm limit.

Radiated emissions no input signal 30MHz – 1GHz

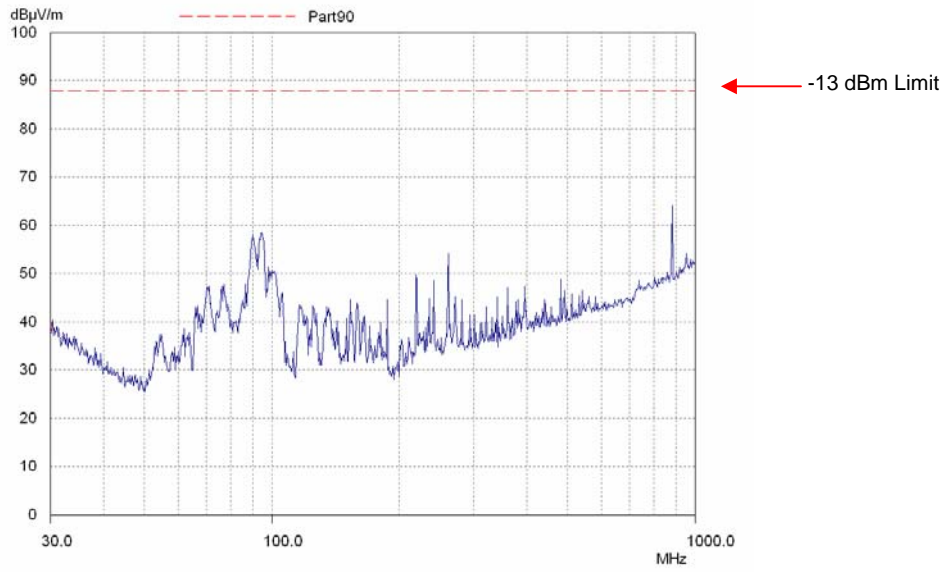

Radiated emissions no input signal 1GHz – 3GHz

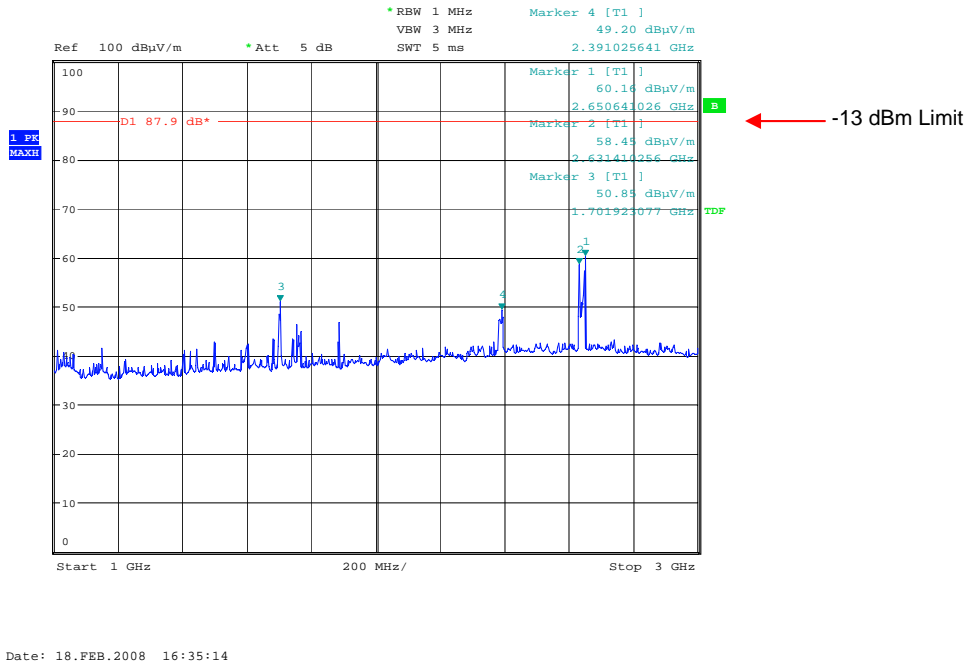

The above test results show that there were no emissions within 20dBs of the -13dBm limit.

Radiated emissions no input signal 3GHz – 6GHz

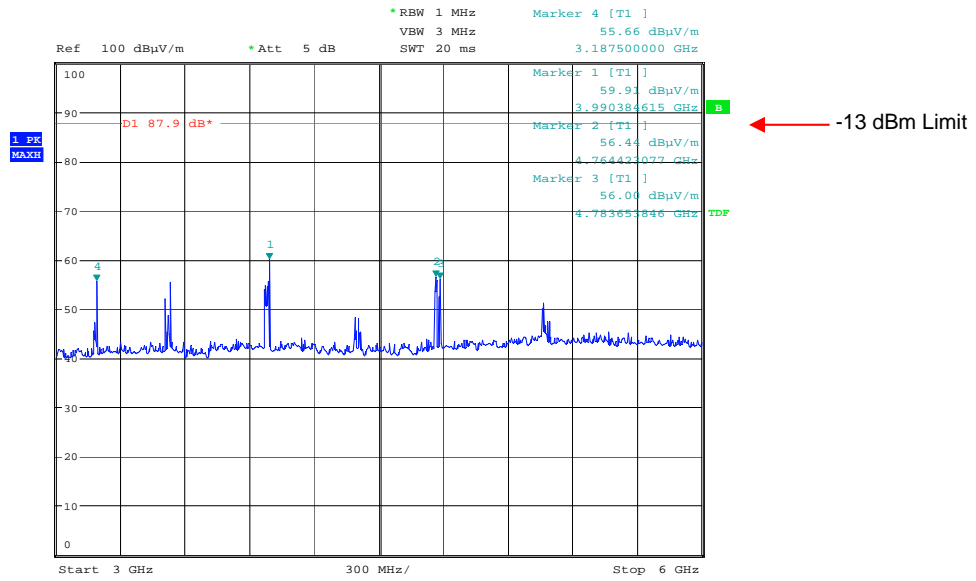

Date: 18.FEB.2008 16:35:57

Radiated emissions no input signal 6GHz – 9GHz

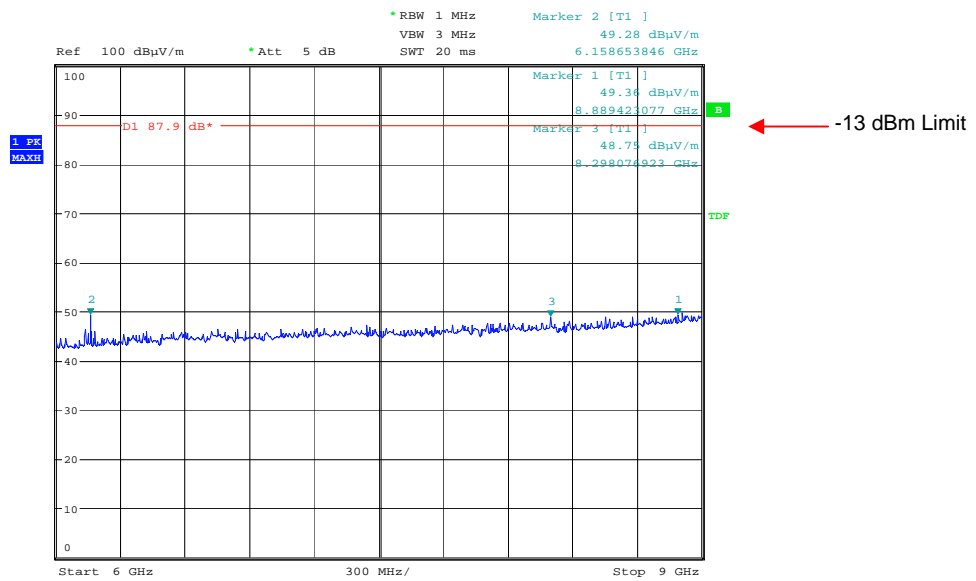

Date: 18.FEB.2008 16:37:08

The above test results show that there were no emissions within 20dBs of the -13dBm limit.

AMPLIFIER GAIN – CONDUCTED – PART 2.1046 – DOWNLINK

Ambient temperature = 14°C
 Relative humidity = 38%
 Supply voltage = +110Vac
 Channel number = See test results

Radio Laboratory

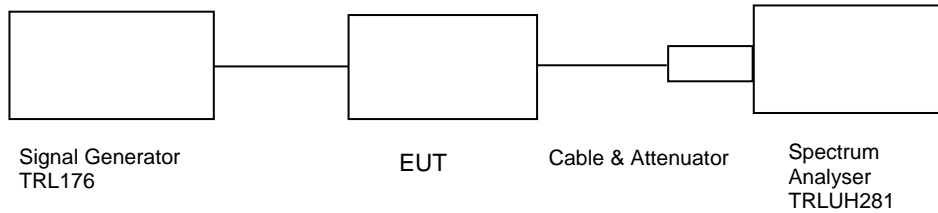

Frequency MHz	Signal Generator input level dBm	Input Cable Loss dB	Output Cable & Attenuator loss dB	Level at Spectrum Analyser dBm	Gain dB	Conducted Output Power dBm	Gain after 10dB input level increase dB
854.9625	-12	0.5	36.6	-1.38	47.72	35.22	37.83
857.4625	-12	0.5	36.6	-1.46	47.64	35.14	37.83
860.9625	-12	0.5	36.6	-1.27	47.83	34.77	37.96

Notes: 1. The signal generator input was increased by 10dBs and the level of the output signal remeasured.

TYPE OF EQUIPMENT	MAKER/SUPPLIER	MODEL No	SERIAL No	TRL No	ACTUAL EQUIPMENT USED
SPECTRUM ANALYSER	RHODE & SCHWARZ	FSU46	200034	UH281	X
ATTENUATOR	BIRD	8304-300-N	N/A	220	X
ATTENUATOR	BIRD	8304-100-N	N/A	222	X
CABLE	TRL	N/A	N/A	UH273	X
CABLE	TRL	N/A	N/A	UH274	X
SIGNAL GENERATOR	MARCONI	2042	119388/080	176	X

AMPLIFIER INTERMODULATION SPURIOUS EMISSIONS – CONDUCTED – PART 2.1053– DOWNLINK

Ambient temperature = 17°C
 Relative humidity = 36%
 Supply voltage = +110Vac

Radio Laboratory

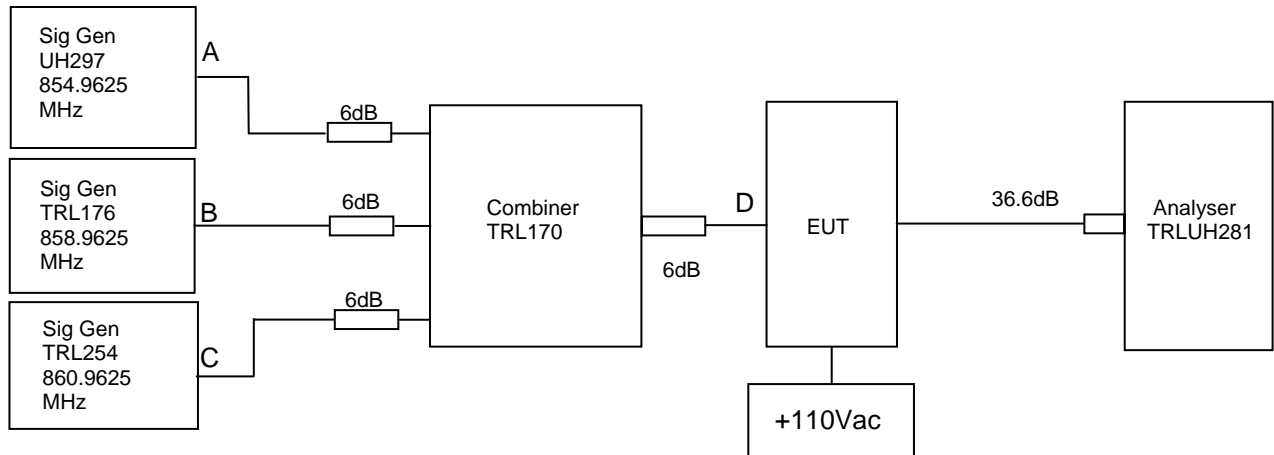

The intermodulation and spurious products were measured with the amplifier operating at maximum gain. A three tone test was conducted using the equipment as above. The input power level was adjusted so the level at point D was 10dB above the maximum input of -12dBm. The cable and attenuator loss between the EUT and the spectrum analyser was 36.6dB.

RF Input Frequency (MHz)			Highest Intermodulation Product Level (dBm)	Limit (dBm)
854.9625	858.9625	860.9625	-15.28 dBm @ 856.9727MHz	-13

Sweep data is shown on the next page:

Test equipment used for intermodulation test

TYPE OF EQUIPMENT	MAKER/SUPPLIER	MODEL No	SERIAL No	TRL No	ACTUAL EQUIPMENT USED
SPECTRUM ANALYSER	ANRITSU	MS2665C	MT26089	479	
SPECTRUM ANALYSER	R&S	FSU46	200034	UH281	X
SIGNAL GENERATOR	MARCONI	2042	119388/080	176	X
SIGNAL GENERATOR	R&S	SML 03	102268	UH297	X
SIGNAL GENERATOR	MARCONI	2042	119562/021	254	X
SIGNAL GENERATOR	HP	83630B	3722A00588	UH340	
CMTA	ROHDE & SCHWARZ	CMTA52	894715/033	05	
COMBINER	ELCOM	RC-4-50	N/A	170	X

Intermodulation Inband

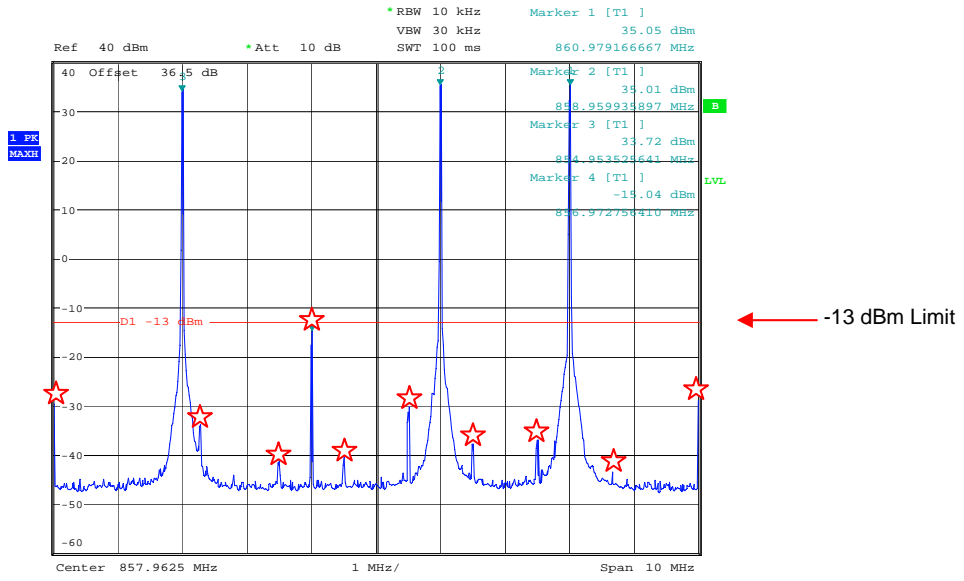

Date: 19.FEB.2008 15:39:15

10MHz Span

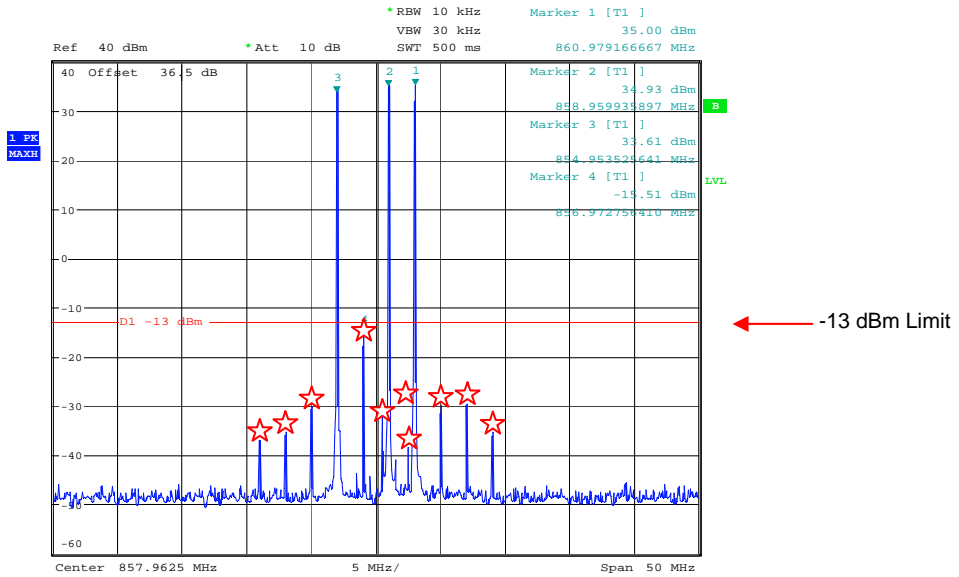

Date: 19.FEB.2008 15:39:30

50MHz Span

The above plots show that all products (designated by ☆) are below the spurious limit.

Intermodulation Wideband

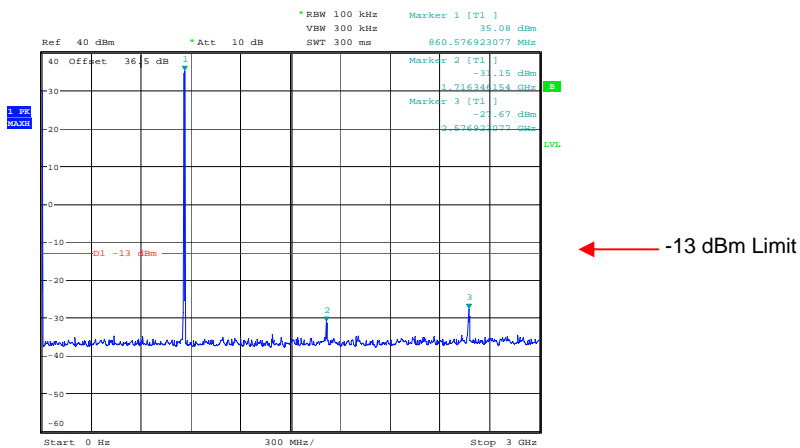

Date: 19.FEB.2008 15:40:11

0Hz - 3GHz

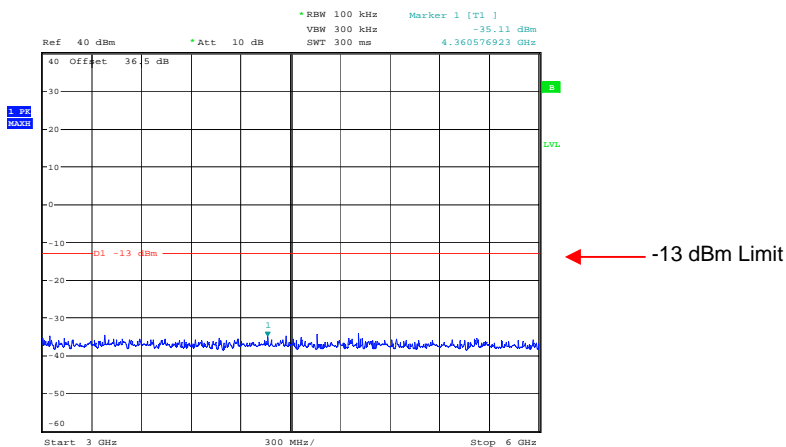

Date: 19.FEB.2008 15:40:28

3GHz - 6GHz

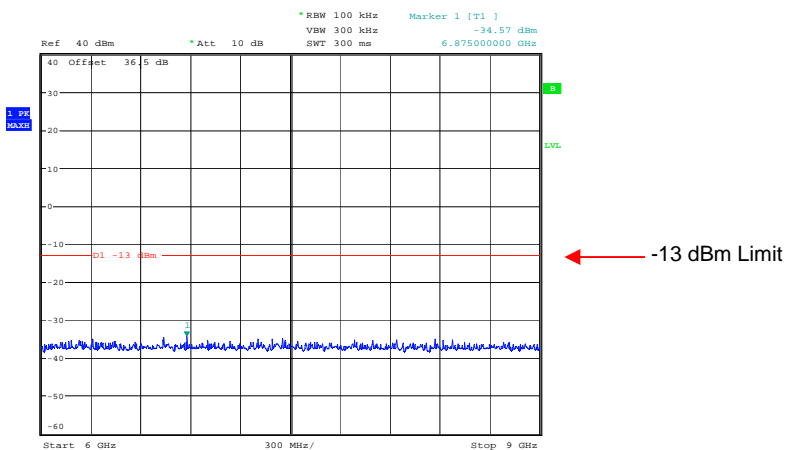

Date: 19.FEB.2008 15:40:43

6GHz - 9GHz

The above plot shows that products outside the band are below the spurious limit.

TRANSMITTER TESTS

AMPLIFIER MODULATED CHANNEL TEST – CONDUCTED – Part 2.1049– DOWNLINK

Ambient temperature = 16°C Radio Laboratory
 Relative humidity = 34%
 Supply voltage = +110Vac
 Channel number = See test results

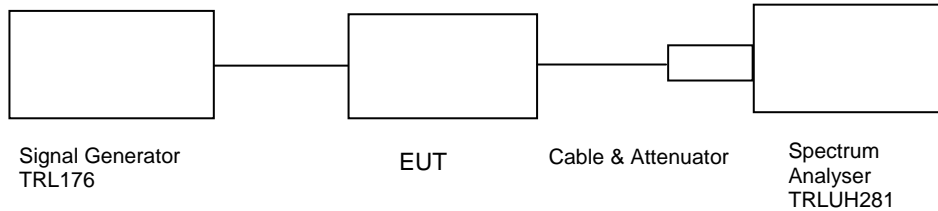

This test was performed to show that the amplifier does not alter the input signal in any way. The input signal was set to the maximum input level (-12dBm) and modulated with a 2500Hz tone. The plots show the signal measured at the signal generator and the signal measured at the output of the EUT.

Note: The cables and attenuators had the following losses.

1. Cable and attenuator between EUT and spectrum analyser 36.6dB
2. Cable between signal generator and EUT 0.5dB

TYPE OF EQUIPMENT	MAKER/SUPPLIER	MODEL No	SERIAL No	TRL No	ACTUAL EQUIPMENT USED
SPECTRUM ANALYSER	RHODE & SCHWARZ	FSU46	200034	UH281	X
ATTENUATOR	BIRD	8304-300-N	N/A	220	X
ATTENUATOR	BIRD	8304-100-N	N/A	222	X
CABLE	TRL	N/A	N/A	UH273	X
CABLE	TRL	N/A	N/A	UH274	X
SIGNAL GENERATOR	MARCONI	2042	119388/080	176	X

854.9625 MHz Signal Generator, deviation set to 5kHz

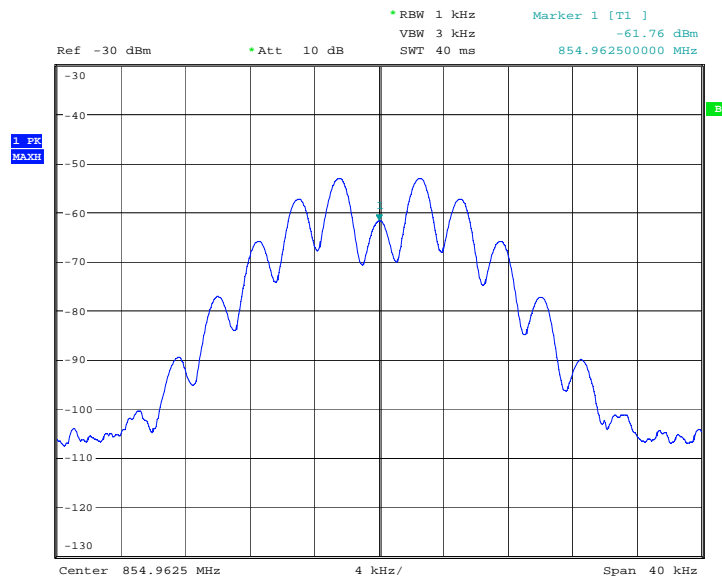

Date: 19.FEB.2008 11:08:17

854.9625 MHz Signal Generator and EUT, deviation set to 5kHz

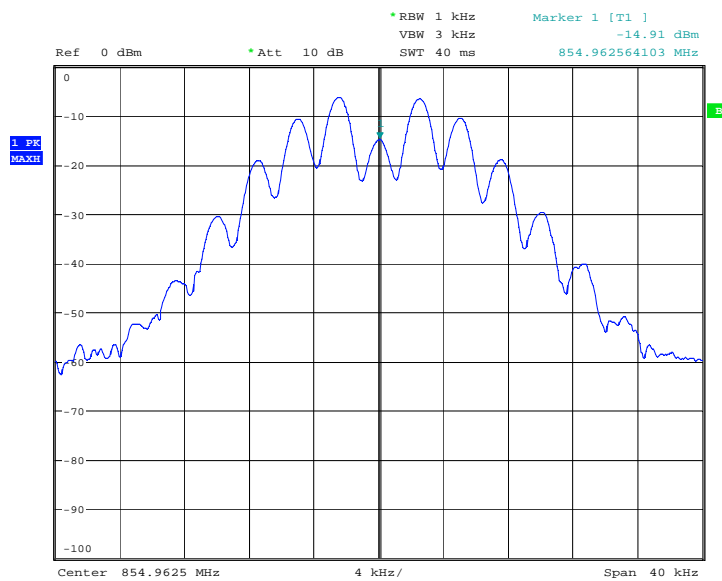

Date: 19.FEB.2008 11:04:32

The above plots depicting the output wavelshape show no measurable distortion visible when compared to the input signal.

857.4625 MHz Signal Generator, deviation set to 5kHz

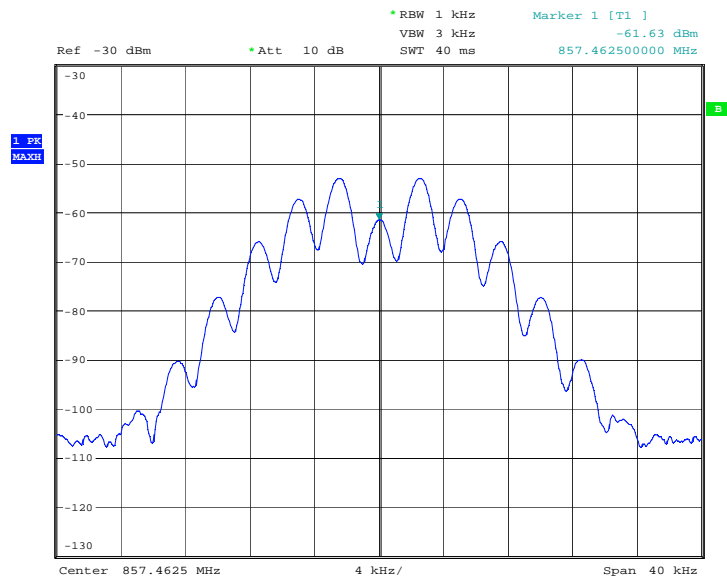

Date: 19.FEB.2008 11:07:47

857.4625 MHz Signal Generator and EUT, deviation set to 5kHz

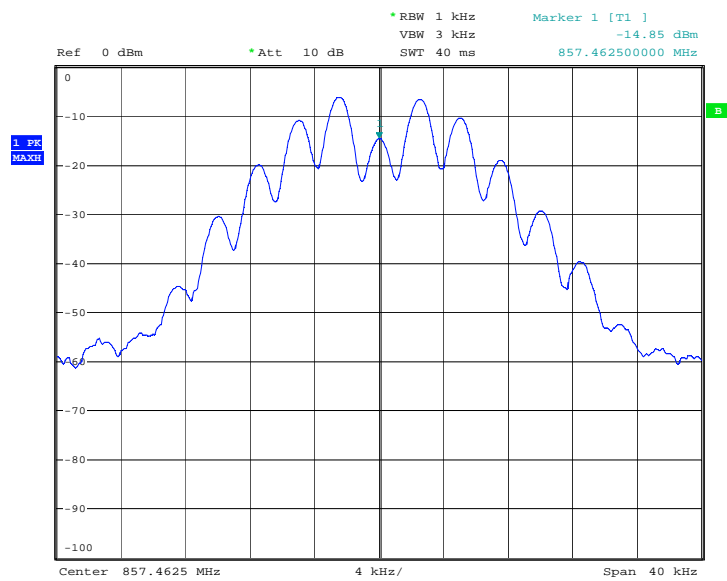

Date: 19.FEB.2008 11:04:56

The above plots depicting the output wavelshape show no measurable distortion visible when compared to the input signal.

860.9625 MHz Signal Generator, deviation set to 5kHz

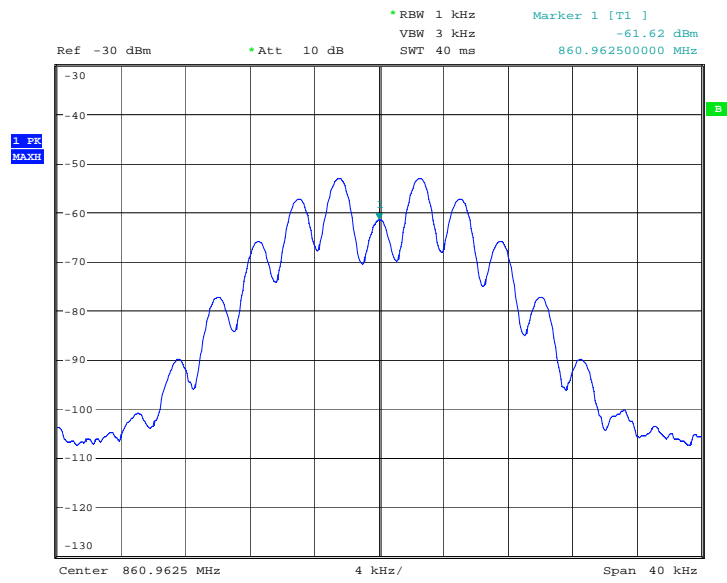

Date: 19.FEB.2008 11:06:56

860.9625 MHz Signal Generator and EUT, deviation set to 5kHz

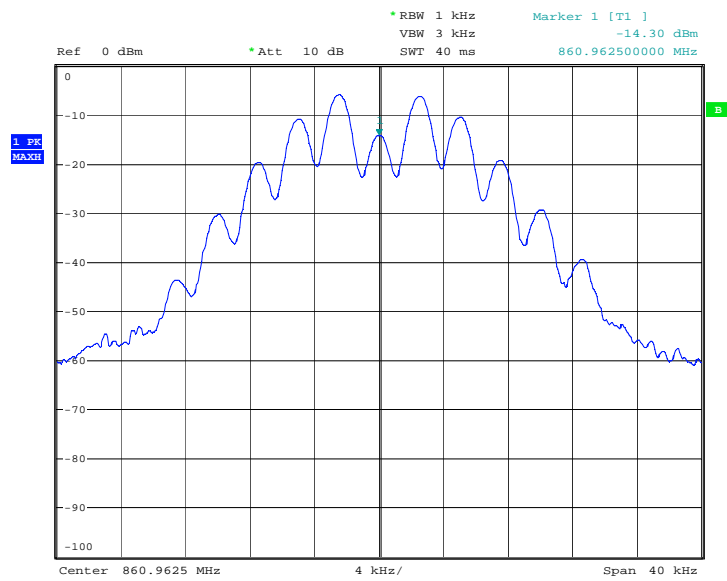

Date: 19.FEB.2008 11:05:53

The above plots depicting the output wavelshape show no measurable distortion visible when compared to the input signal.

TRANSMITTER TESTS

AMPLIFIER SPURIOUS EMISSIONS – CONDUCTED – Part 2.1053 – DOWNLINK

Ambient temperature = 16°C
 Relative humidity = 34%
 Supply voltage = +110Vac

Radio Laboratory
 Test Signal = F3E

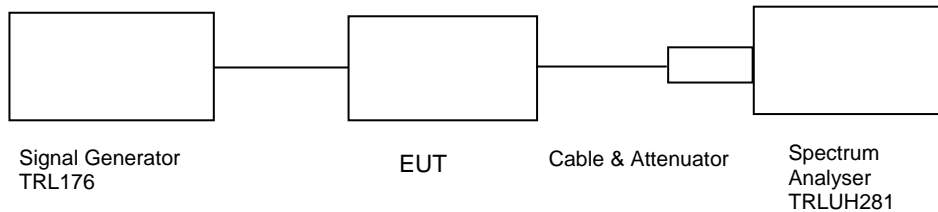

The test was set up as per the diagram. The level at the input was adjusted to compensate for the loss of the interconnecting cable. The unit was tested operating at maximum power and on three test frequencies.

The Spurious limit was calculated as follows:

On any frequency removed from the assigned frequency by more than 250% of the authorised bandwidth

At least 43 + 10 log PdB

$$(10\log P_{\text{watts}}) - (43 + 10\log (P_{\text{watts}} * 1000)) = \text{LIMIT} = -13 \text{ dBm}$$

RESULTS

FREQUENCY RANGE	FREQ. (MHz)	MEASURED LEVEL (dBm)	ATTENUATOR & CABLE LOSSES (dB)	EMISSION LEVEL (dBm)	LIMIT (dBm)
0Hz – 9GHz	No Significant Emissions Within 20dB of the limit.				-13

The test equipment used for the Transmitter Conducted Emissions:

TYPE OF EQUIPMENT	MAKER/SUPPLIER	MODEL No	SERIAL No	TRL No	ACTUAL EQUIPMENT USED
SPECTRUM ANALYSER	RHODE & SCHWARZ	FSU46	200034	UH281	X
ATTENUATOR	BIRD	8304-300-N	N/A	220	X
ATTENUATOR	BIRD	8304-100-N	N/A	222	X
CABLE	TRL	N/A	N/A	UH273	X
CABLE	TRL	N/A	N/A	UH274	X
SIGNAL GENERATOR	MARCONI	2042	119388/080	176	X

Conducted emissions 854.9625 MHz 0Hz – 3GHz

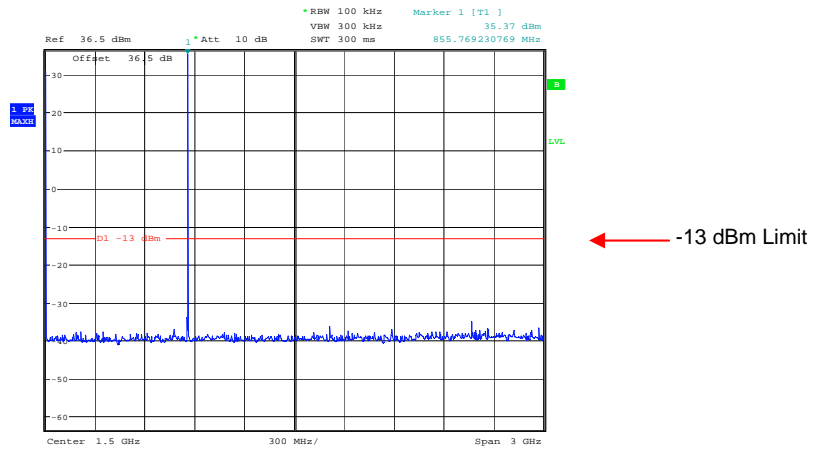

Date: 19.FEB.2008 09:56:29

Conducted emissions 854.9625 MHz 3GHz – 6GHz

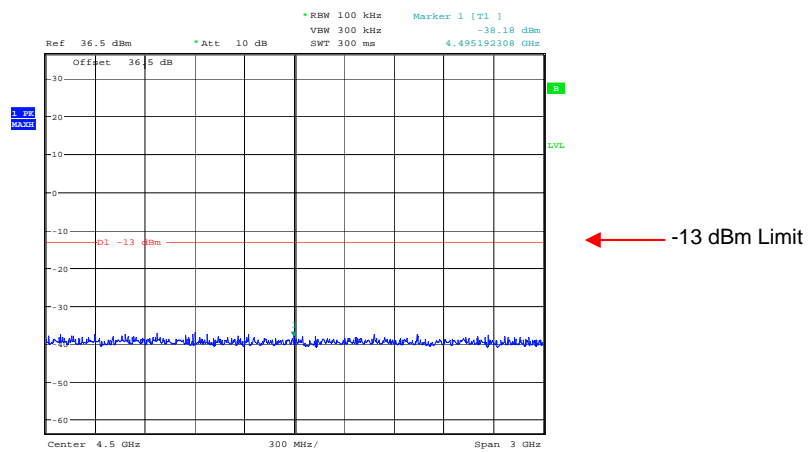

Date: 19.FEB.2008 09:57:12

Conducted emissions 854.9625 MHz 6GHz – 9GHz

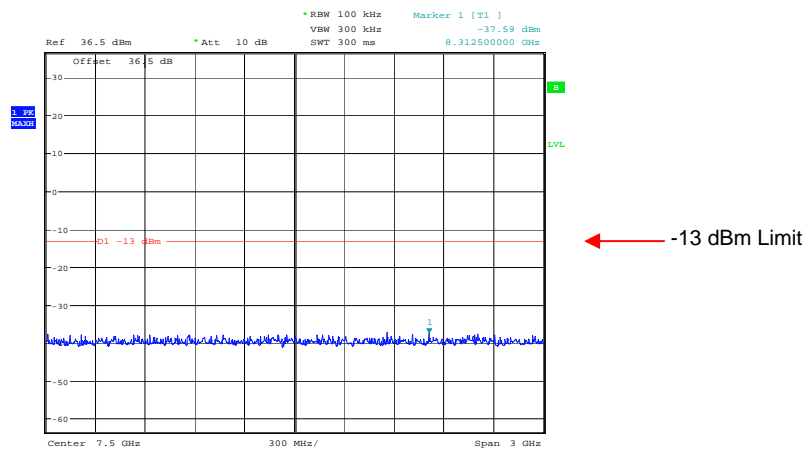

Date: 19.FEB.2008 09:57:00

Conducted emissions 857.4625 MHz 0Hz – 3GHz

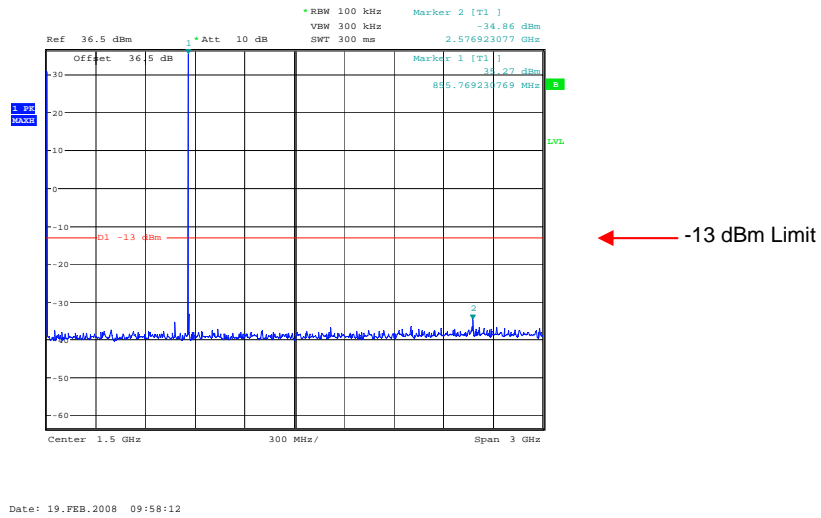

Conducted emissions 857.4625 MHz 3GHz – 6GHz

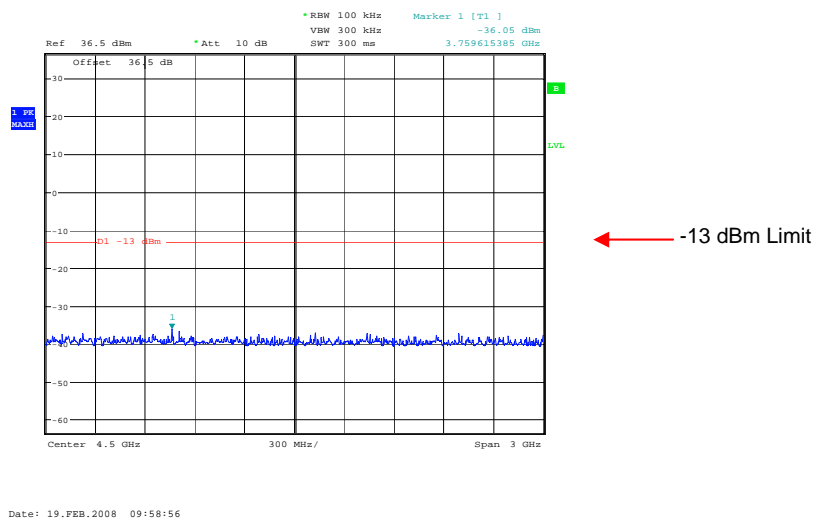

Conducted emissions 857.4625 MHz 6GHz – 9GHz

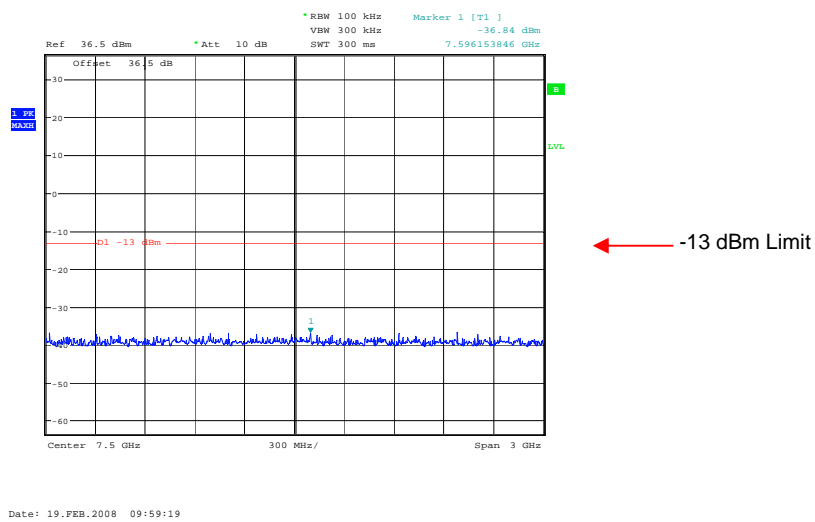

Conducted emissions 860.9625 MHz 0Hz – 3GHz

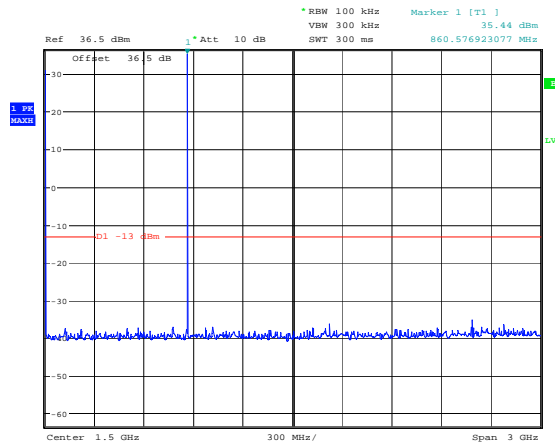

← -13 dBm Limit

Date: 19.FEB.2008 09:59:50

Conducted emissions 860.9625 MHz 3GHz – 6GHz

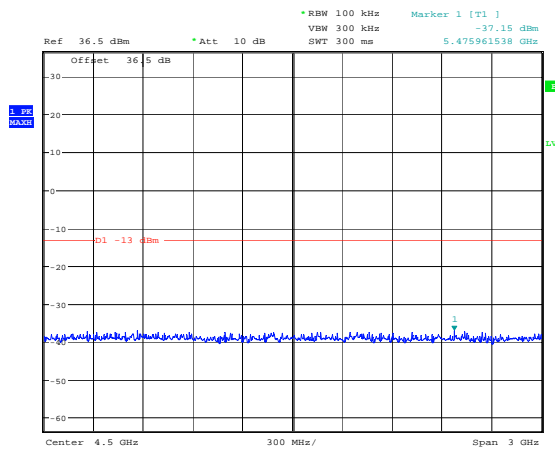

← -13 dBm Limit

Date: 19.FEB.2008 10:00:18

Conducted emissions 860.9625 MHz 6GHz – 9GHz

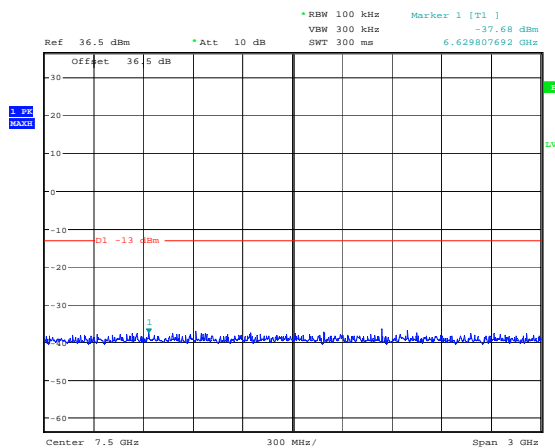

← -13 dBm Limit

Date: 19.FEB.2008 10:00:36

TRANSMITTER TESTS

AMPLIFIER SPURIOUS EMISSIONS – RADIATED – Part 2.1053– DOWNLINK

Ambient temperature = 14°C
 Relative humidity = 38%
 Conditions = OATS
 Supply voltage = +110Vac
 Supply Frequency = N/A

Test Signal = F3E

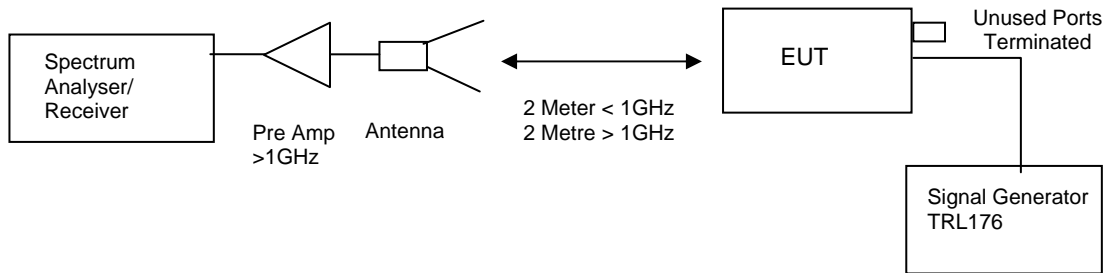

The test was set up as per the diagram. The level at the input was adjusted to compensate for the loss of the interconnecting cable. The unit was tested operating maximum power on three test frequencies with a 50 ohm load on the output. The unit was also tested with the signal generator replaced by another 50ohm load.

The Spurious limit was calculated as follows:

On any frequency removed from the assigned frequency by more that 250% of the authorised bandwidth

At least 43 + 10 log PdB

$$(10\log P_{\text{watts}}) - (43+10\log (P_{\text{watts}} * 1000)) = \text{LIMIT} = -13 \text{ dBm}$$

RESULTS

FREQUENCY RANGE	FREQ. (MHz)	MEAS. Rx. (dBµV)	CABLE LOSS (dB)	ANT FACTOR	FIELD STRENGTH (dBµV/m)	CALCULATED EIRP (dBm)	LIMIT (dBm)
30MHz – 9GHz	No Significant Emissions Within 20 dB of the Limit						-13

The test equipment used for the Transmitter Spurious Emissions:

TYPE OF EQUIPMENT	MAKER/ SUPPLIER	MODEL No	SERIAL No	TRL No	ACTUAL EQUIPMENT USED
HORN	EMCO	3115	9010-3581	139	X
SPECTRUM ANALYSER	R&S	FSU46	200034	UH281	X
PRE AMPLIFIER	HP	8449B	3008A016	572	X
SIGNAL GENERATOR	MARCONI	2042	119388/080	176	X
ANTENNA	YORK	CBL611/A	1618	UH191	X
RECEIVER	R&S	ESVS10	825892/006	UH04	X

Radiated emissions 854.9625 MHz 30MHz – 1GHz

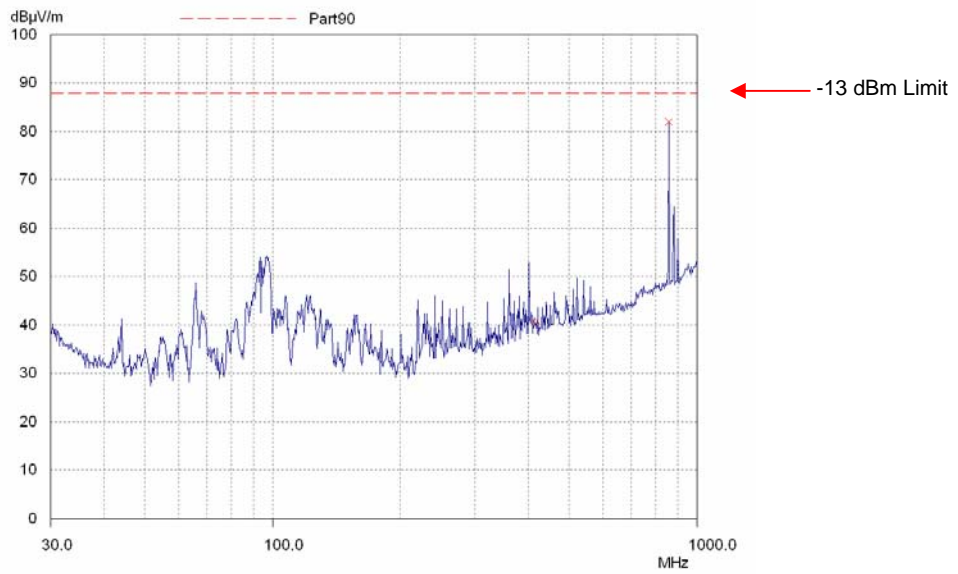

Radiated emissions 854.9625 MHz 1GHz – 3GHz

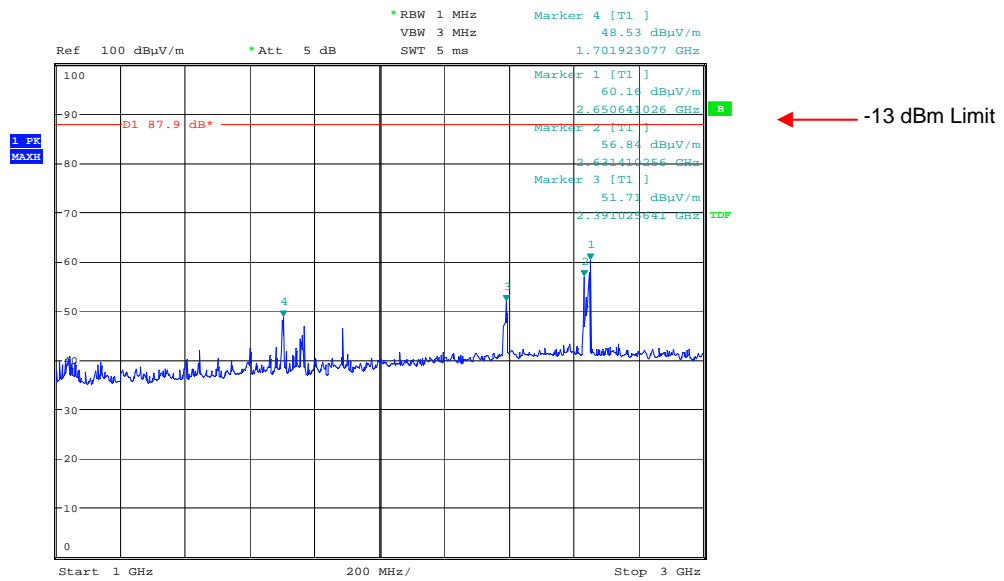

Date: 18.FEB.2008 15:13:52

The above test results show that there were no emissions within 20dBs of the -13dBm limit.

Radiated emissions 854.9625 MHz 3GHz – 6GHz

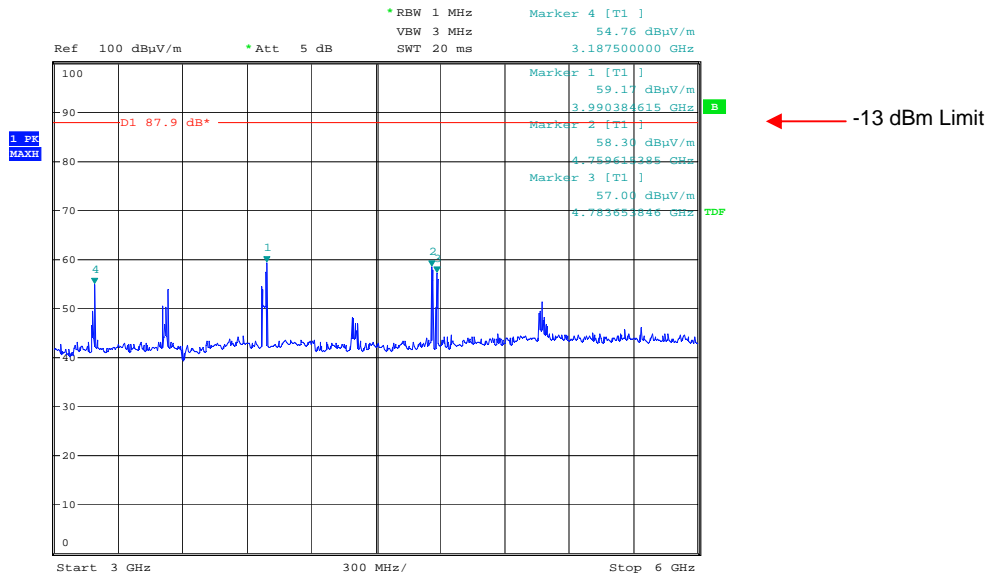

Date: 18.FEB.2008 15:15:01

Radiated emissions 854.9625 MHz 6GHz – 9GHz

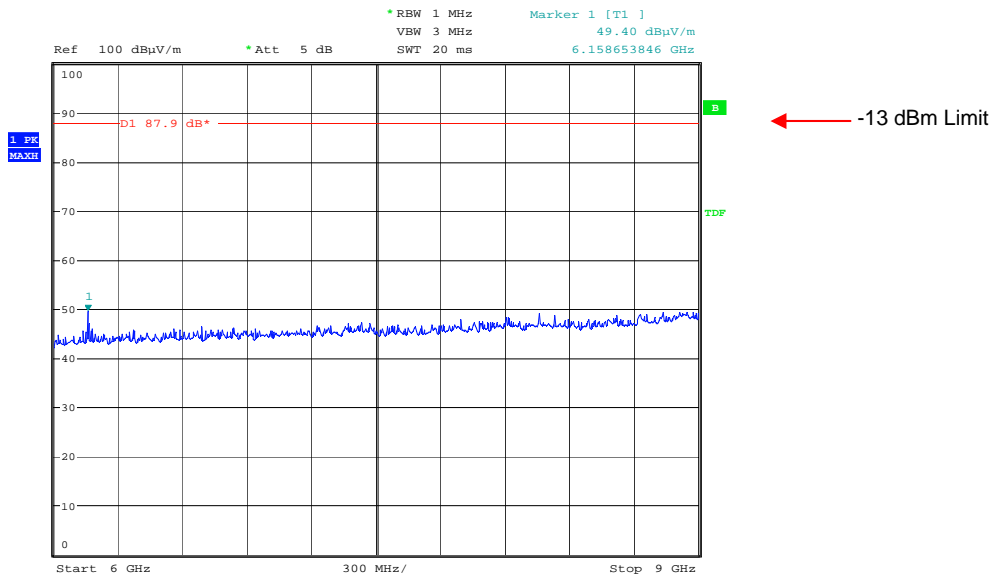

Date: 18.FEB.2008 15:15:50

The above test results show that there were no emissions within 20dBs of the -13dBm limit.

Radiated emissions 857.4625 MHz 30MHz – 1GHz

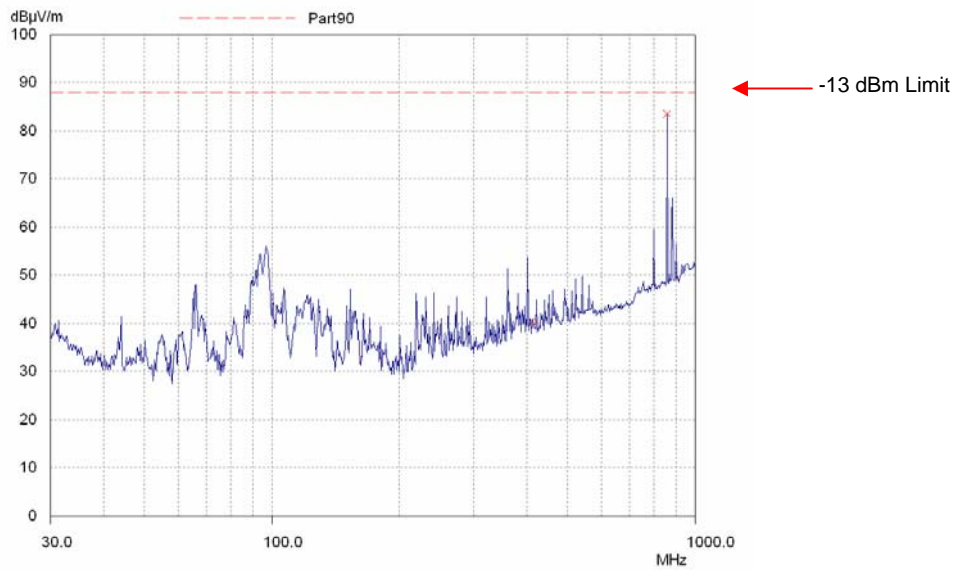

Radiated emissions 857.4625 MHz 1GHz – 3GHz

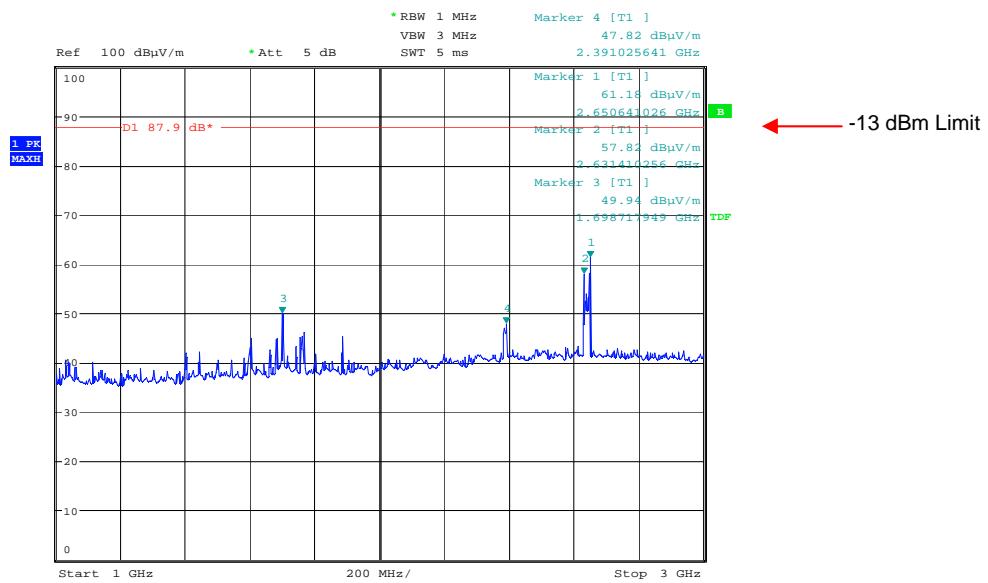

Date: 18.FEB.2008 15:27:52

The above test results show that there were no emissions within 20dBs of the -13dBm limit.

Radiated emissions 857.4625 MHz 3GHz – 6GHz

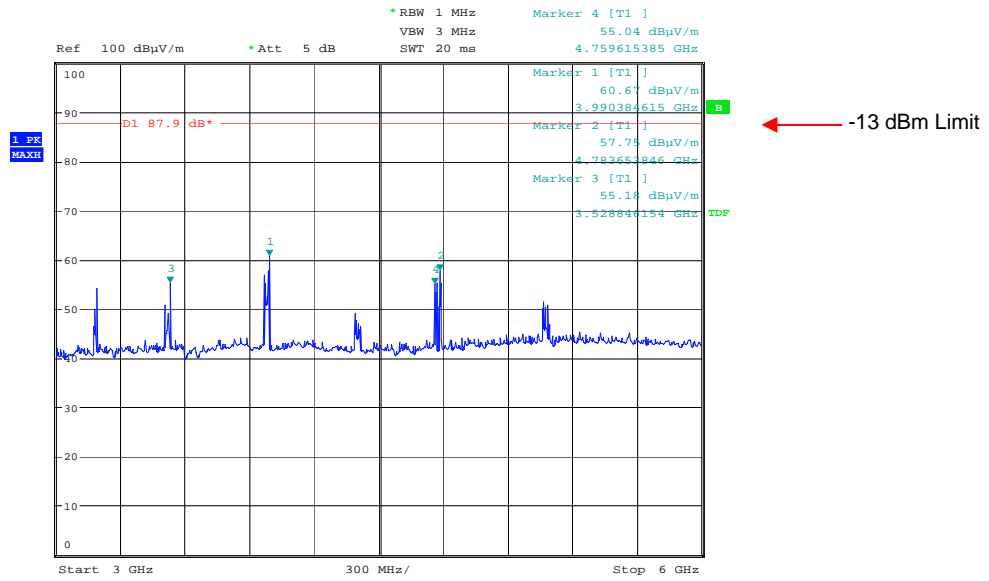

Date: 18.FEB.2008 15:28:44

Radiated emissions 857.4625 MHz 6GHz – 9GHz

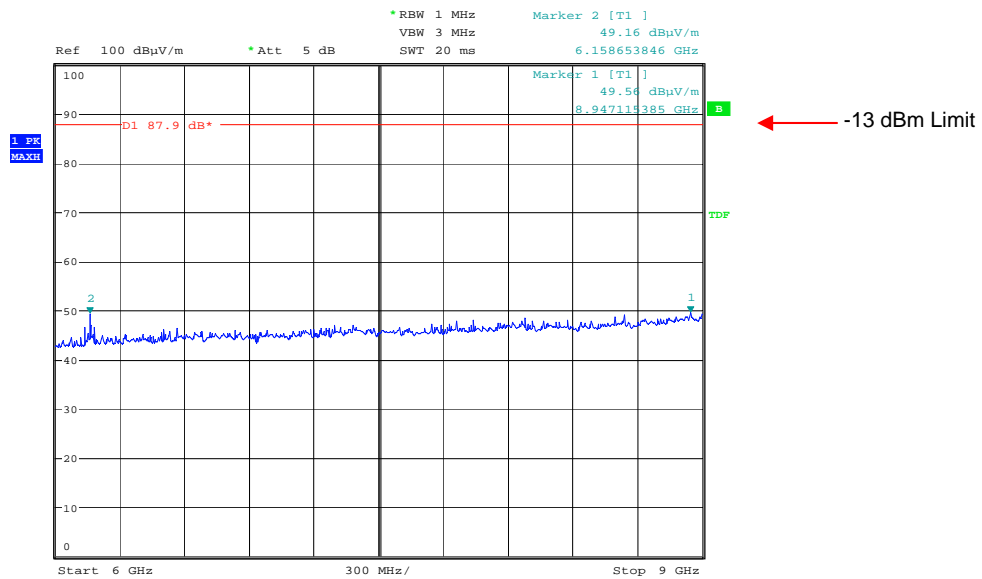

Date: 18.FEB.2008 15:29:41

The above test results show that there were no emissions within 20dBs of the -13dBm limit.

Radiated emissions 860.9625 MHz 30MHz – 1GHz

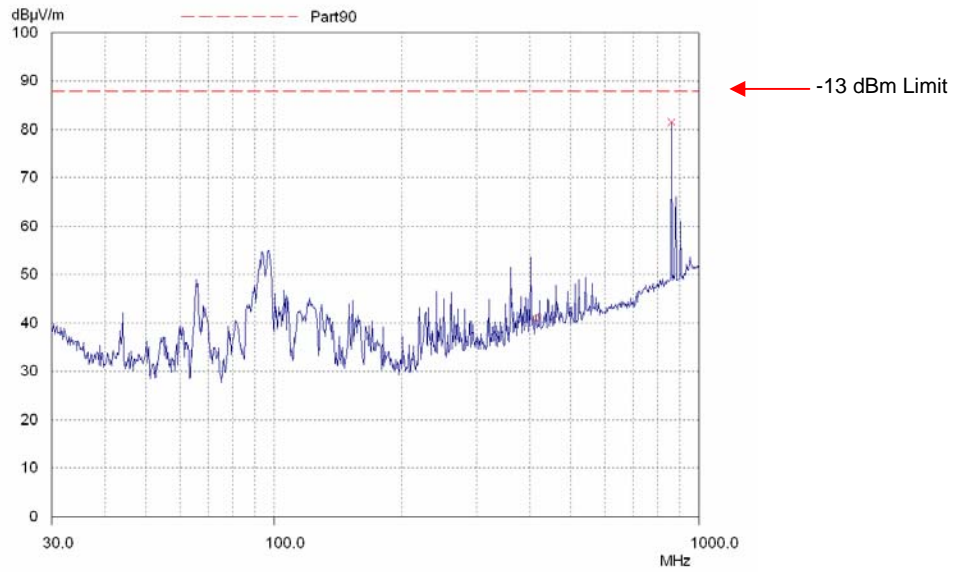

Radiated emissions 860.9625 MHz 1GHz – 3GHz

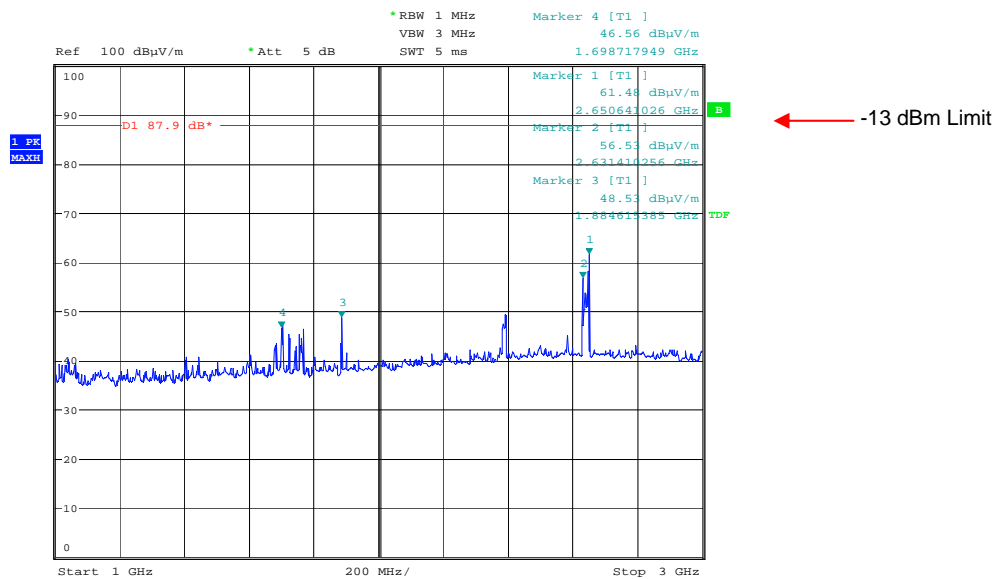

Date: 18.FEB.2008 15:32:12

The above test results show that there were no emissions within 20dBs of the -13dBm limit.

Radiated emissions 860.9625 MHz 3GHz – 6GHz

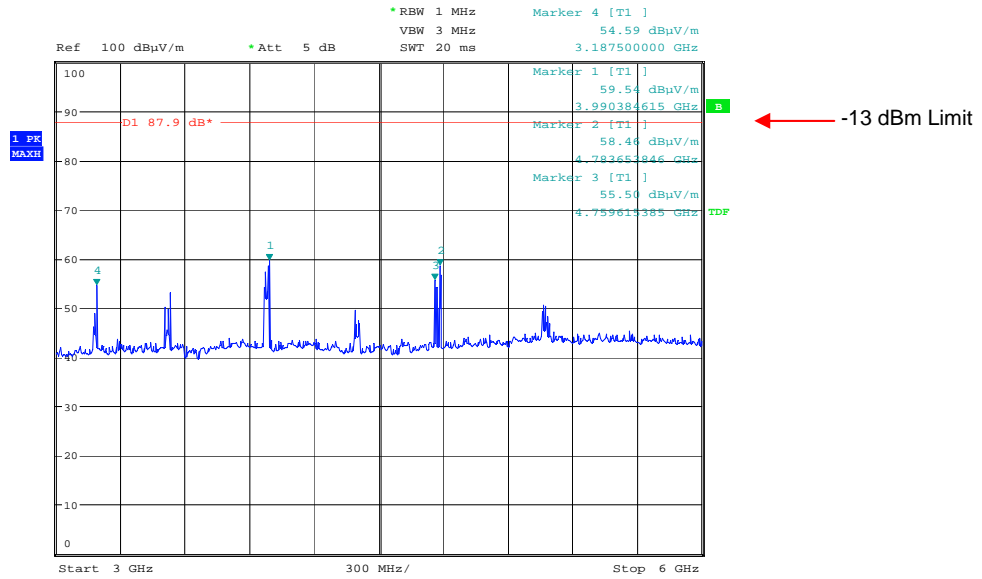

Date: 18.FEB.2008 15:32:59

Radiated emissions 860.9625 MHz 6GHz – 9GHz

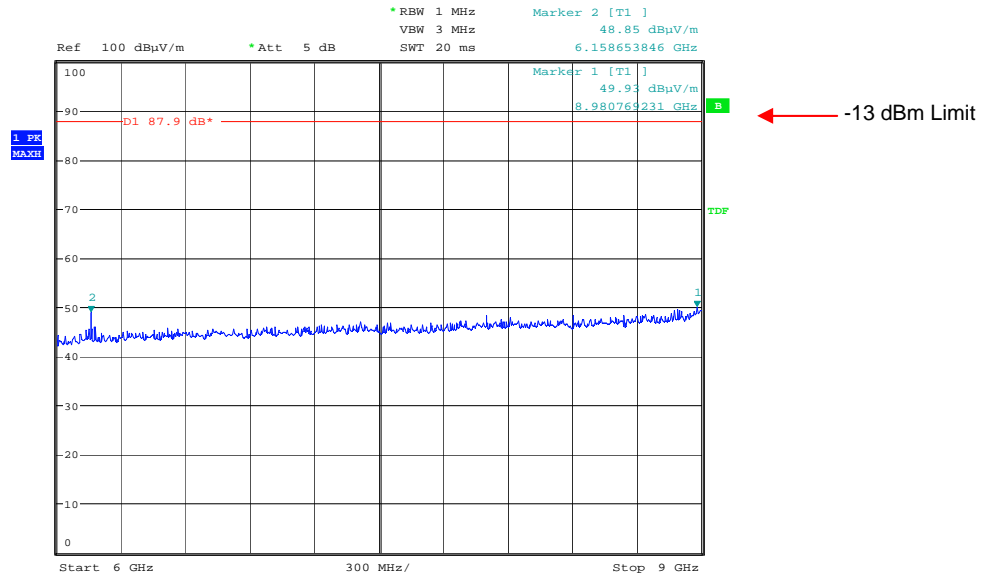

Date: 18.FEB.2008 15:34:16

The above test results show that there were no emissions within 20dBs of the -13dBm limit.

Radiated emissions no input signal 30MHz – 1GHz

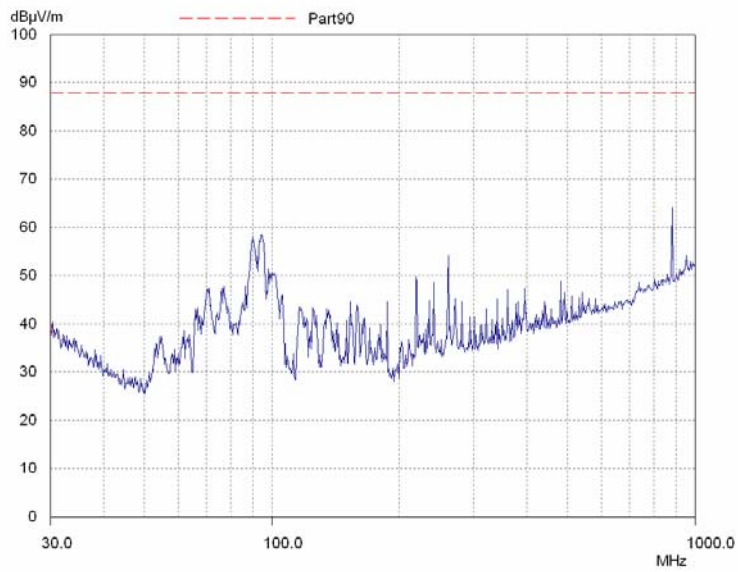

Radiated emissions no input signal 1GHz – 3GHz

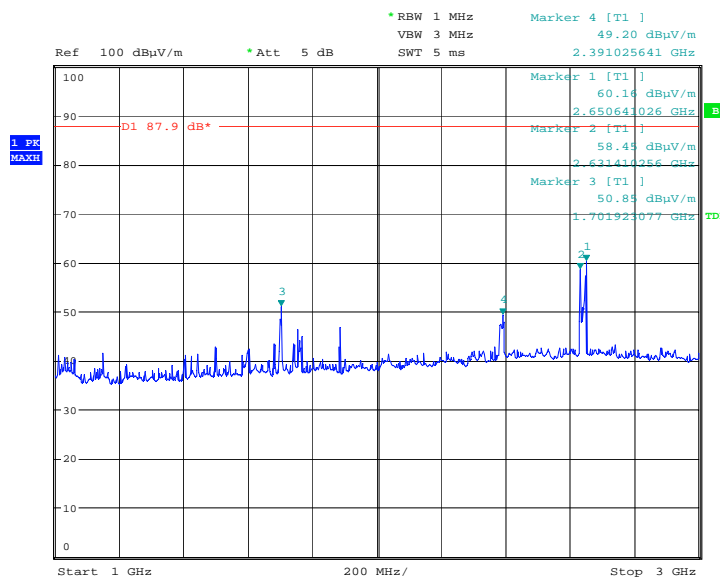

Date: 18.FEB.2008 16:35:14

The above test results show that there were no emissions within 20dBs of the -13dBm limit.

Radiated emissions no input signal 3GHz – 6GHz

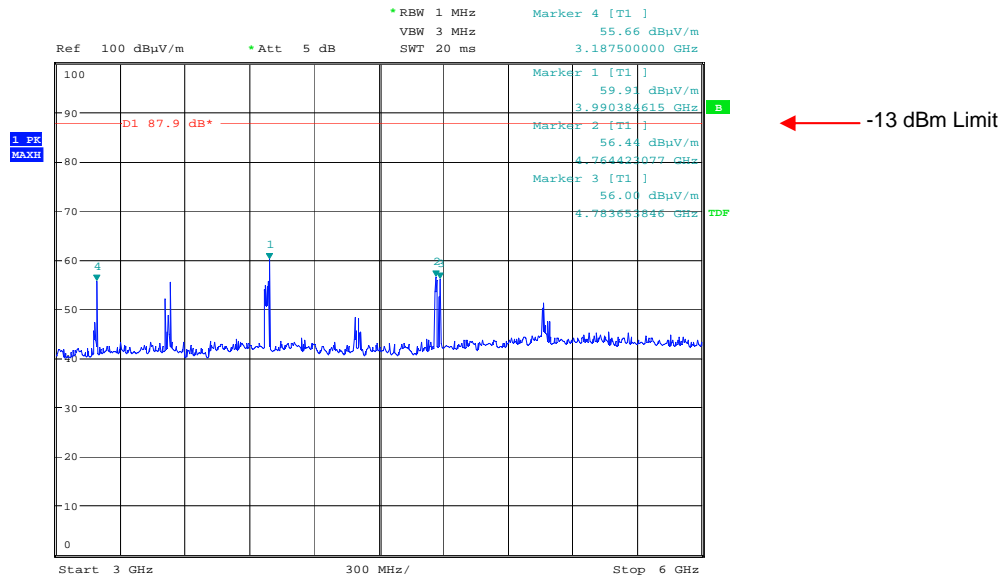

Date: 18.FEB.2008 16:35:57

Radiated emissions no input signal 6GHz – 9GHz

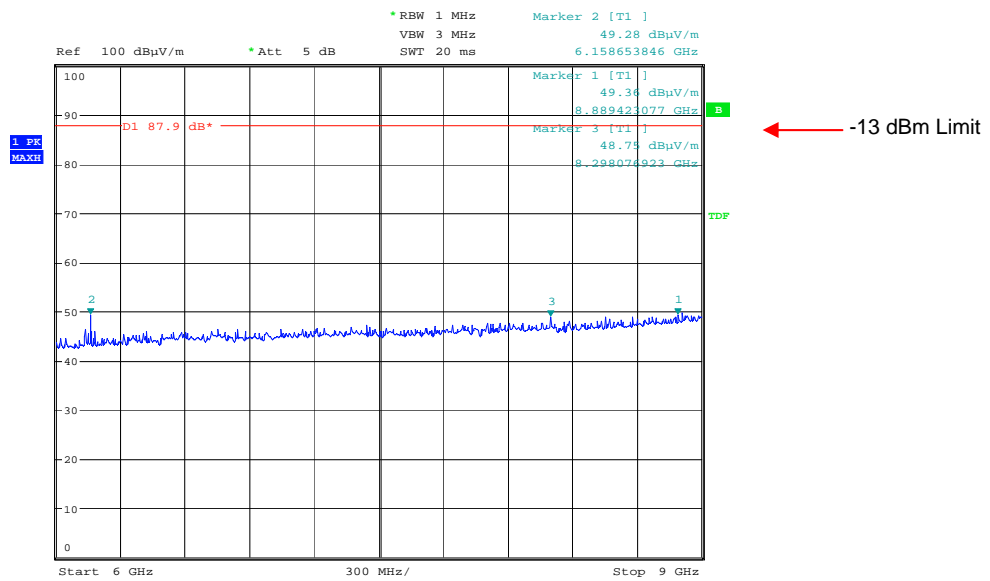

Date: 18.FEB.2008 16:37:08

The above test results show that there were no emissions within 20dBs of the -13dBm limit.

ANNEX A
PHOTOGRAPHS

PHOTOGRAPH No. 1

TEST SETUP





ANNEX B
APPLICANT'S SUBMISSION OF DOCUMENTATION LIST

APPLICANT'S SUBMISSION OF DOCUMENTATION LIST

a.	TCB	-	APPLICATION	[X]
		-	FEE	[X]
b.	AGENT'S LETTER OF AUTHORISATION	-		[X]
c.	MODEL(s) vs IDENTITY	-		[]
d.	ALTERNATIVE TRADE NAME DECLARATION(s)	-		[]
e.	LABELLING	-	PHOTOGRAPHS	[]
		-	DECLARATION	[]
		-	DRAWINGS	[]
f.	TECHNICAL DESCRIPTION	-		[X]
g.	BLOCK DIAGRAMS	-	Tx	[X]
		-	Rx	[]
		-	PSU	[]
		-	AUX	[]
h.	CIRCUIT DIAGRAMS	-	Tx	[X]
		-	Rx	[]
		-	PSU	[]
		-	AUX	[]
i.	COMPONENT LOCATION	-	Tx	[]
		-	Rx	[]
		-	PSU	[]
		-	AUX	[]
j.	PCB TRACK LAYOUT	-	Tx	[]
		-	Rx	[]
		-	PSU	[]
		-	AUX	[]
k.	BILL OF MATERIALS	-	Tx	[X]
		-	Rx	[]
		-	PSU	[]
		-	AUX	[]
l.	USER INSTALLATION / OPERATING INSTRUCTIONS	-		[X]

ANNEX C
EQUIPMENT CALIBRATION

TRL Number	Equipment Type	Manufacturer	Last Cal Calibration	Calibration Period	Due For Calibration
UH004	Receiver	R&S	06/11/2007	12	06/11/2008
UH06/07	IC OATS Submission	TRL	01/06/2007	24	01/06/2009
UH06/07	NSA Calibration	TRL	17/12/2007	12	17/12/2008
UH191	Antenna	York	11/08/2006	21	11/08/2008
UH273	Cable	TRL		Calibrate in Use	
UH274	Cable	TRL		Calibrate in Use	
UH281	Spectrum Analyser	R&S	24/10/2007	12	24/10/2008
UH297	Signal Generator	R&S	30/05/2007	12	30/05/2008
L138	1-18GHz Horn	EMCO	23/05/2007	24	23/05/2009
L170	Combiner	Elcom		Calibrate in Use	
L176	Signal Generator	Marconi	01/03/2007	12	01/03/2008
L220	Attenuator	Bird		Calibrate in Use	
L222	Attenuator	Bird		Calibrate in Use	
L254	Signal Generator	Marconi	27/02/2007	12	27/02/2008
L572	Pre Amp	Agilent		Calibrate in Use	

ANNEX D
MEASUREMENT UNCERTAINTY

Radio Testing – General Uncertainty Schedule

All statements of uncertainty are expanded standard uncertainty using a coverage factor of 1.96 to give a 95% confidence where no required test level exists.

[1] Adjacent Channel Power

Uncertainty in test result = **1.86dB**

[2] Carrier Power

Uncertainty in test result (Equipment - TRLUH120) = **2.18dB**

Uncertainty in test result (Equipment – TRL05) = **1.08dB**

Uncertainty in test result (Equipment – TRL479) = **2.48dB**

[3] Effective Radiated Power

Uncertainty in test result = **4.71dB**

[4] Spurious Emissions

Uncertainty in test result = **4.75dB**

[5] Maximum frequency error

Uncertainty in test result (Equipment - TRLUH120) = **119ppm**

Uncertainty in test result (Equipment – TRL05) = **0.113ppm**

Uncertainty in test result (Equipment – TRL479) = **0.265ppm**

[6] Radiated Emissions, field strength OATS 14kHz-18GHz Electric Field

Uncertainty in test result (14kHz – 30MHz) = **4.8dB**, Uncertainty in test result (30MHz – 1GHz) = **4.6dB**,

Uncertainty in test result (1GHz-18GHz) = **4.7dB**

[7] Frequency deviation

Uncertainty in test result = **3.2%**

[8] Magnetic Field Emissions

Uncertainty in test result = **2.3dB**

[9] Conducted Spurious

Uncertainty in test result (Equipment TRL479) Up to 8.1GHz = **3.31dB**

Uncertainty in test result (Equipment TRL479) 8.1GHz – 15.3GHz = **4.43dB**

Uncertainty in test result (Equipment TRL479) 15.3GHz – 21GHz = **5.34dB**

Uncertainty in test result (Equipment TRLUH120) Up to 26GHz = **3.14dB**

[10] Channel Bandwidth

Uncertainty in test result = **15.5%**

[11] Amplitude and Time Measurement – Oscilloscope

Uncertainty in overall test level = **2.1dB**, Uncertainty in time measurement = **0.59%**, Uncertainty in Amplitude measurement = **0.82%**

[11] Power Line Conduction

Uncertainty in test result = **3.4dB**

[12] Spectrum Mask Measurements

Uncertainty in test result = **2.59% (frequency)**
Uncertainty in test result = **1.32dB (amplitude)**

[13] Adjacent Sub Band Selectivity

Uncertainty in test result = **1.24dB**

[14] Receiver Blocking – Listen Mode, Radiated

Uncertainty in test result = **3.42dB**

[15] Receiver Blocking – Talk Mode, Radiated

Uncertainty in test result = **3.36dB**

[16] Receiver Blocking – Talk Mode, Conducted

Uncertainty in test result = **1.24dB**

[17] Receiver Threshold

Uncertainty in test result = **3.23dB**

[18] Transmission Time Measurement

Uncertainty in test result = **7.98%**