

A RADIO TEST REPORT

FOR

Axell Wireless Limited

ON

Digital Fibre Fed Band Selective Repeater

BSF3302-150-174-DP4-AC

DOCUMENT NO. TRA-026466-47-00-C

HULL

Unit E, South Orbital Trading Park, Hedon Road, Hull, HU9 1NJ, UK.

T +44 (0)1482 801801 **F** +44 (0)1482 801806 **E** test@tracglobal.com

www.tracglobal.com

TRaC Wireless Test Report : TRA-026466-47-00-C

Applicant : Axell Wireless Limited

Apparatus : BSF3302-150-174-DP4-AC

Specification(s) : CFR47 Part 90

Purpose of Test : Certification

FCCID : NEO61-200SERIES

Authorised by :

: Radio Product Manager

Issue Date :12th January 2016

Authorised Copy Number : *PDF*

Contents

Section 1:	Introduction	4
1.1	General	4
1.2	Tests Requested By	5
1.3	Manufacturer	5
1.4	Apparatus Assessed	5
1.5	Test Result Summary	6
1.6	Equipment Test Conditions	7
1.7	Standard References	8
1.8	Notes Relating To Assessment	9
1.9	Deviations from Test Standards	10
1.10	Test Site	10
Section 2:	Measurement Uncertainty	11
2.1	Measurement Uncertainty Values	11
Section 3:	Modifications	13
3.1	Modifications Performed During Assessment	13
Appendix A:	Uplink Formal Emission Test Results	14
A1	RF Gain and Output Power	15
A2	Amplifier Intermodulation Spurious Emissions	16
A3	Amplifier Modulated Channel Test	23
A4	Spurious Emissions at Antenna Terminals Less than 1MHz	28
A5	Spurious Emissions at Antenna Terminals Greater than 1MHz	29
A6	Noise at Antenna Terminals	33
A7	Radiated Electric Field Emissions	35
A8	Passband Gain & Bandwidth	40
Appendix B:	Downlink Formal Emission Test Results	42
B1	RF Gain and Output Power	43
B2	Amplifier Intermodulation Spurious Emissions	44
B3	Amplifier Modulated Channel Test	51
B4	Spurious Emissions at Antenna Terminals Less than 1MHz	57
B5	Spurious Emissions at Antenna Terminals Greater than 1MHz	60
B6	Noise at Antenna Terminals	64
B7	Radiated Electric Field Emissions	68
B8	Passband Gain & Bandwidth	73
Appendix C:	Additional Test and Sample Details	75
Appendix D:	Additional Information	81

Section 1:**Introduction****1.1 General**

This report contains an assessment of an apparatus against Electromagnetic Compatibility Standards based upon tests carried out on samples submitted to the Laboratory.

Test performed by: TRaC Global []
Unit E
South Orbital Trading Park
Hedon Road
Hull, HU9 1NJ.
United Kingdom.

Telephone: +44 (0) 1482 801801
Fax: +44 (0) 1482 801806

TraC Global [X]
Unit 1
Pendle Place
Skelmersdale
West Lancashire, WN8 9PN
United Kingdom

Telephone: +44 (0) 1695 556666
Fax: +44 (0) 1695 577077

Email: test@tracglobal.com
Web site: <http://www.tracglobal.com>

Tests performed by: S Hodgkinson

Report author: S Hodgkinson

This report must not be reproduced except in full without prior written permission from TRaC Global.

1.2 Tests Requested By

This testing in this report was requested by:

Axell Wireless
Aerial House
Asheridge Road
Chesham
Buckinghamshire
HP5 1TU

1.3 Manufacturer

Axell Wireless
Aerial House
Asheridge Road
Chesham
Buckinghamshire
HP5 1TU

1.4 Apparatus Assessed

The following apparatus was assessed between the 11th May – 18th May 2015

The BSF3302-150-174-DP4-AC is a Digital Fiber Fed Band Selective Repeater
For the purposes of testing the device was setup to operating the following bands.

Lower 5MHz Band 150.0 MHz – 155.0MHz
Middle 5MHz Band 159.2 MHz – 164.2MHz
Upper 5MHz Band 169.0 MHz – 173.4 MHz

The BSF3302 provides effective and secure radio coverage in any VHF network and provides two variable bandwidth blocks of contiguous spectrum.

1.5 Test Result Summary

Full details of test results are contained within Appendix A. The following table summarises the results of the assessment.

The statements relating to compliance with the standards below apply ONLY as qualified in the notes and deviations stated in sections 1.6 to 1.7 of this test report.

Full details of test results are contained within Appendix A. The following table summarises the results of the assessment.

Test Type	FCC Part	Appendix in Report	Result
RF Gain and Power Output	90.219(e)(1)	A1 & B1	Pass
Intermodulation Spurious Emissions	90.219(e)(3)	A2 & B2	Pass
Occupied Bandwidth & Modulation	90.219(a) 90.219(4)(e)(ii) 90.210(d)	A3 & B3	Pass
Spurious Emissions at Antenna Terminals Less than 1MHz	90.219(e)(3) 90.210(d)	A4 & B4	Pass
Spurious Emissions at Antenna Terminals Greater than 1MHz	90.219(e)(3)	A5 & B5	Pass
Noise At Antenna Terminals	90.219(e)(2) 90.219(d)(6)(ii)	A6 & B6	Pass
Field Strength of Spurious Emissions	90.219(e)(3)	A7 & B7	Pass
Passband Gain & 20dB bandwidth	N/A	A8 & B8	Pass
Frequency Stability	90.213	N/A(note 1)	N/A
Transient behaviour	90.214	N/A(note 2)	N/A
Audio Frequency Response (a)	TIA EIA-603.3.2.6	N/A	N/A
Modulation Limiting	TIA EIA-603.3.2.6	N/A	N/A

Notes:

1 The EUT does not contain modulation circuitry; therefore the test was not performed.

2 The EUT is not a keyed carrier system; therefore the test was not performed.

Abbreviations used in the above table:

CFR : Code of Federal Regulations
REFE : Radiated Electric Field Emissions
A Uplink Results Appendix

ANSI : American National Standards Institution
PLCE : Power Line Conducted Emissions
B Downlink Results Appendix

1.6 Equipment Test Conditions

Product class:	Uplink	Class A <input type="checkbox"/> Class B <input checked="" type="checkbox"/>
	Downlink	Class A <input type="checkbox"/> Class B <input checked="" type="checkbox"/>
Product Use:	Private Land Mobile Repeater	
Supply Voltages:	Vnom	110Vac
Note: Vnom voltages are as stated above unless otherwise shown on the test report page		
Equipment Category:	Single channel	<input type="checkbox"/>
	Two channel	<input type="checkbox"/>
	Multi-channel	<input checked="" type="checkbox"/>
Test Location	TRaC Global	
	Skelmersdale	<input checked="" type="checkbox"/>
	Hull	<input type="checkbox"/>
	Other	<input type="checkbox"/> Please Specify

1.7 Standard References

47 CFR 2	Code of Federal Regulations, Title 47, Part 2, "Frequency allocations and Radio Telemetry Matters; General Rules and Regulations"
47 CFR 90	Code of Federal Regulations, Title 47, Part 90, "Land Mobile Radio Service"
C63.10-2013	American National Standards Institute (ANSI), "Methods of Measurement of Radio Noise Emissions from Low Voltage Electrical and Electronic Equipment in the Range 9 kHz to 40 GHz"
TIA EIA-603-D	Land Mobile FM or PM Communications Equipment Measurement and Performance Standards

1.8 Notes Relating To Assessment

With regard to this assessment, the following points should be noted:

The results contained in this report relate only to the items tested and were obtained in the period between the date of initial receipt of samples and the date of issue of the report.

The apparatus was set up and exercised using the configurations, modes of operation and arrangements defined in this report only.

Particular operating modes, apparatus monitoring methods and performance criteria required by the standards tested to have been performed except where modified in Section 1.7 of this test report (Deviations from Test Standards).

For emissions testing, throughout this test report, "Pass" indicates that the results for the sample as tested were below the specified limit (refer also to Section 2, Measurement Uncertainty).

Where relevant, the apparatus was only assessed using the monitoring methods and susceptibility criteria defined in this report.

All testing with the exception of testing at the Open Area Test Site was performed under the following environmental conditions:

Temperature	: 17 to 23 °C
Humidity	: 45 to 75 %
Barometric Pressure	: 86 to 106 kPa

All dates used in this report are in the format dd/mm/yy.

This assessment has been performed in accordance with the requirements of ISO/IEC 17025.

1.9 Deviations from Test Standards

There were no deviations from the standards tested to.

1.10 Test Site

Location	Chamber Number	Site Type	Used For testing
Pendle Place Skelmersdale	EMC Chamber 1	ATS	
	EMC Chamber 2	ATS	
	REF 940 Radio	ATS	X

OATS – Open area test site
ATS - Alternative Test Site

Section 2:**Measurement Uncertainty****2.1 Measurement Uncertainty Values**

For the test data recorded the following measurement uncertainty was calculated:

Radio Testing – General Uncertainty Schedule

All statements of uncertainty are expanded standard uncertainty using a coverage factor of 1.96 to give a 95% confidence where no required test level exists.

[1] Adjacent Channel Power

Uncertainty in test result = **1.86dB**

[2] Carrier Power

Uncertainty in test result (Power Meter) = **1.08dB**

Uncertainty in test result (Spectrum Analyser) = **2.48dB**

[3] Effective Radiated Power

Uncertainty in test result = **4.71dB**

[4] Spurious Emissions

Uncertainty in test result = **4.75dB**

[5] Maximum frequency error

Uncertainty in test result (Frequency Counter) = **0.113ppm**

Uncertainty in test result (Spectrum Analyser) = **0.265ppm**

[6] Radiated Emissions, field strength OATS 14kHz-18GHz Electric Field

Uncertainty in test result (14kHz – 30MHz) = **4.8dB**,

Uncertainty in test result (30MHz – 1GHz) = **4.6dB**,

Uncertainty in test result (1GHz – 18GHz) = **4.7dB**

[7] Frequency deviation

Uncertainty in test result = **3.2%**

[8] Magnetic Field Emissions

Uncertainty in test result = **2.3dB**

[9] Conducted Spurious

Uncertainty in test result – Up to 8.1GHz = **3.31dB**

Uncertainty in test result – 8.1GHz – 15.3GHz = **4.43dB**

Uncertainty in test result – 15.3GHz – 21GHz = **5.34dB**

Uncertainty in test result – Up to 26GHz = **3.14dB**

[10] Channel Bandwidth

Uncertainty in test result = **15.5%**

[11] Amplitude and Time Measurement – Oscilloscope

Uncertainty in overall test level = **2.1dB**,
Uncertainty in time measurement = **0.59%**,
Uncertainty in Amplitude measurement = **0.82%**

[12] Power Line Conduction

Uncertainty in test result = **3.4dB**

[13] Spectrum Mask Measurements

Uncertainty in test result = **2.59% (frequency)**
Uncertainty in test result = **1.32dB (amplitude)**

[14] Adjacent Sub Band Selectivity

Uncertainty in test result = **1.24dB**

[15] Receiver Blocking – Listen Mode, Radiated

Uncertainty in test result = **3.42dB**

[16] Receiver Blocking – Talk Mode, Radiated

Uncertainty in test result = **3.36dB**

[17] Receiver Blocking – Talk Mode, Conducted

Uncertainty in test result = **1.24dB**

[18] Receiver Threshold

Uncertainty in test result = **3.23dB**

[19] Transmission Time Measurement

Uncertainty in test result = **7.98%**

Section 3:

Modifications

3.1 Modifications Performed During Assessment

No modifications were performed during the assessment

Appendix A:**Uplink Formal Emission Test Results**

Abbreviations used in the tables in this appendix:

Spec	: Specification	ALSR	: Absorber Lined Screened Room
Mod	: Modification	OATS	: Open Area Test Site
EUT	: Equipment Under Test	ATS	: Alternative Test Site
SE	: Support Equipment	Ref	: Reference
L	: Live Power Line	Freq	: Frequency
N	: Neutral Power Line	MD	: Measurement Distance
E	: Earth Power Line	SD	: Spec Distance
Pk	: Peak Detector	Pol	: Polarisation
QP	: Quasi-Peak Detector	H	: Horizontal Polarisation
Av	: Average Detector	V	: Vertical Polarisation
CDN	: Coupling & decoupling network		

A1 RF Gain and Output Power

Test Details:	
Measurement standard	Part 2.1046, Part 90.219(e)(1)
EUT sample number	S01
Modification state	0
SE in test environment	None
SE isolated from EUT	None
EUT set up	Refer to Appendix C

Frequency MHz	Signal Generator input level dBm	Input Cable Loss dB	Level at Spectrum Analyser dBm	Output Cable & Attenuator loss dB	Gain dB	Conducted Output Power dBm	Gain after 10dB input level increase dB
150.00625	-57.91	0.10	-31.99	3.3	29.32	-28.69	19.28
161.70000	-57.90	0.10	-31.40	3.3	29.90	-28.10	19.82
173.39375	-55.43	0.10	-33.95	3.3	24.88	-30.65	15.90

Notes: 1.The signal generator input was increased by 10dBs and the level of the output signal remeasured.

Industrial booster requirements KDB 935210 D05 the EUT was tested at compression and 10dB into compression to show AGC operation.

A2 Amplifier Intermodulation Spurious Emissions

Test Details:	
Measurement standard	Part 2.1053, 90.219(e)(3)
EUT sample number	S01
Modification state	0
SE in test environment	None
SE isolated from EUT	None
EUT set up	Refer to Appendix C

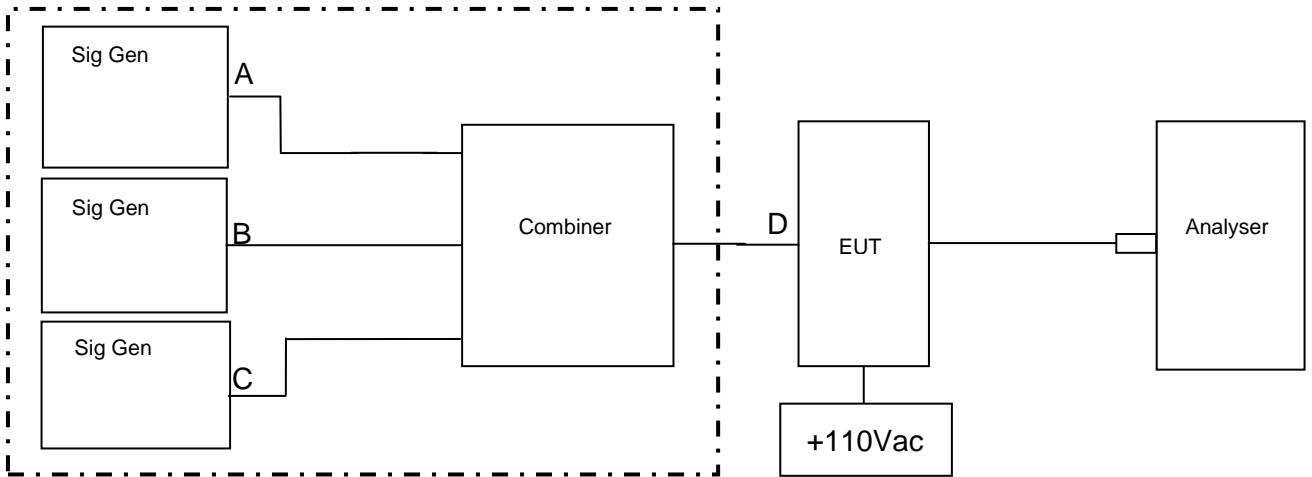

*Signal Generator B was varied in frequency to check if intermodulation products were produced.

RF Input Frequency (MHz)		Highest Intermodulation Product Level (dBm)		Limit (dBm)
Lower 5 MHz Band				
150.00625	*	154.99375	No significant emissions within 10dB	-13
Middle 5MHz Band				
159.20625	*	164.19375	No significant emissions within 10dB	-13
Upper 5 MHz Band				
168.4000	*	173.39375	No significant emissions within 10dB	-13

Sweep data is shown on the next page:

Results

See appendix D for manufactures declaration on good engineering practice.
See plots below

As per Annex .3 Policies + Procedures (k) of KDB 935210 D02 Signal Boosters Certification v03 the EUT was tested at compression and 10dB into compression to show AGC operation, worst case results taken.

Lower 5 MHz band - Intermodulation close View

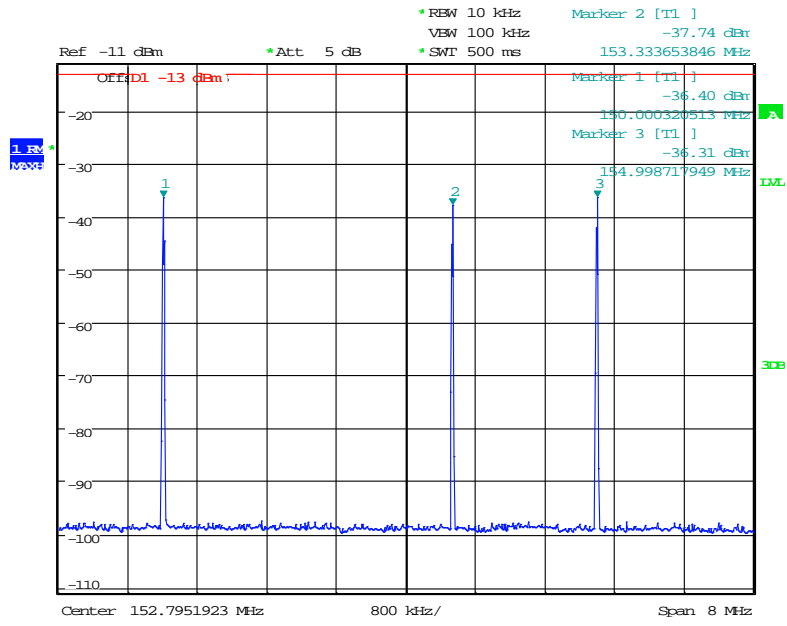

Date: 10.APR.2015 13:00:37

9-150kHz

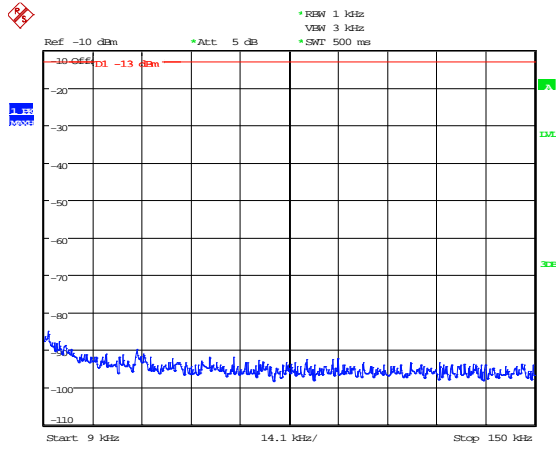

Date: 5.MAY.2015 17:43:58

150kHz – 30MHz

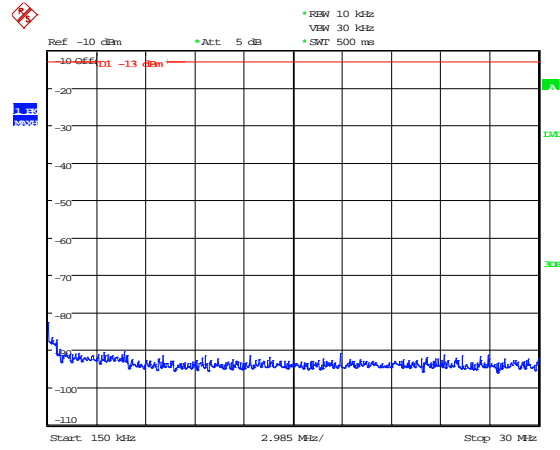

Date: 5.MAY.2015 17:44:23

30MHz – 1GHz

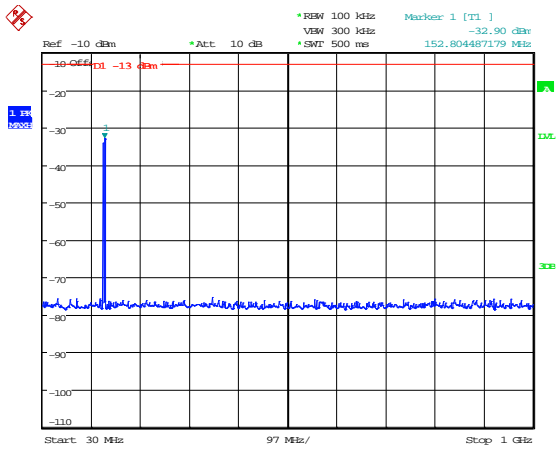

Date: 5.MAY.2015 17:45:23

1GHz – 2GHz

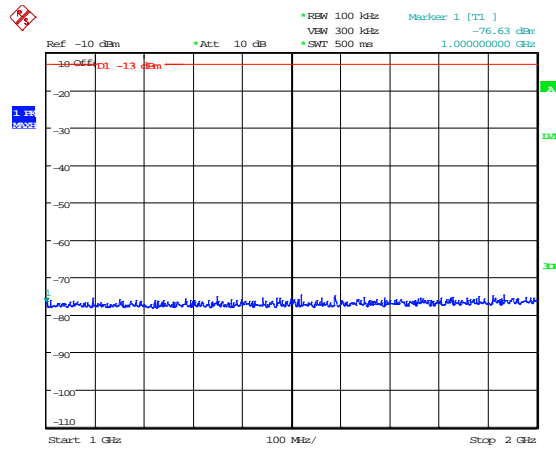

Date: 5.MAY.2015 17:45:50

Mid 5 MHz band - Intermodulation close View

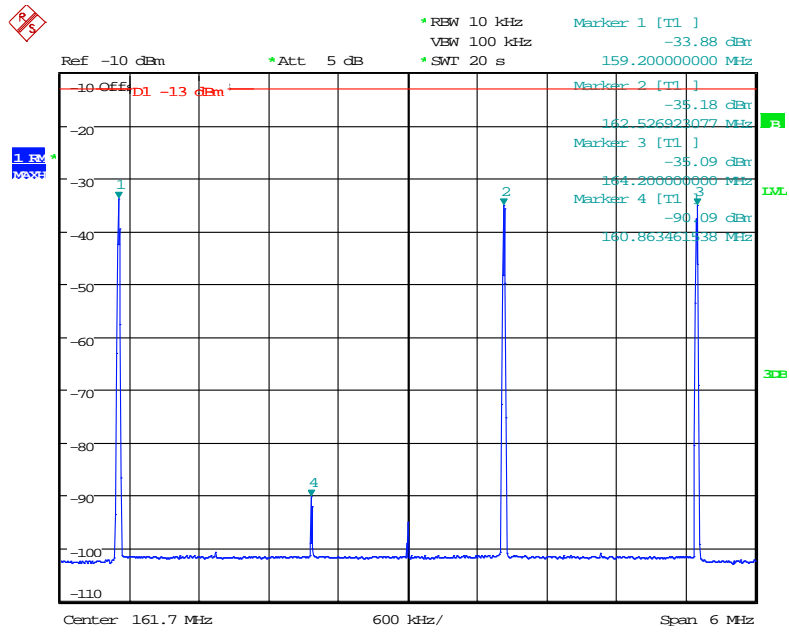

Date: 13.MAY.2015 10:22:44

9-150kHz

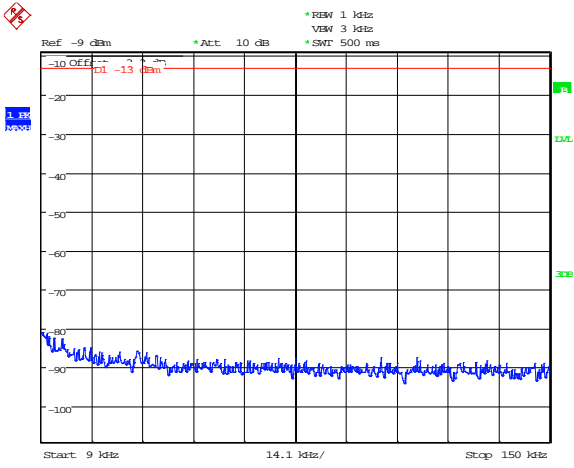

Date: 12.MAY.2015 17:34:15

150kHz – 30MHz

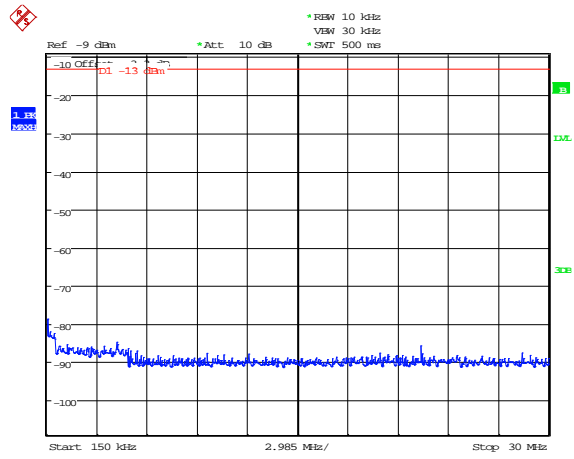

Date: 12.MAY.2015 17:34:40

30MHz – 1GHz

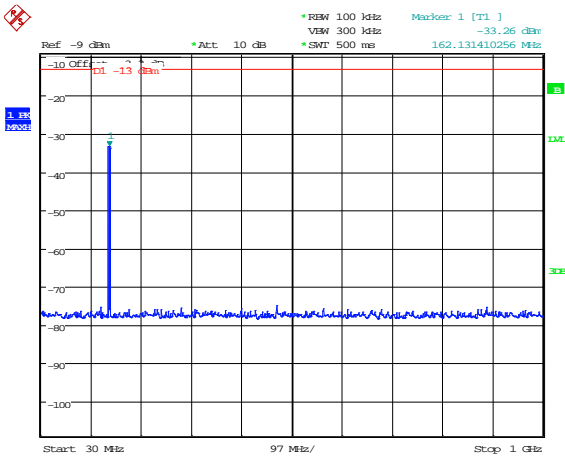

Date: 12.MAY.2015 17:35:13

1GHz – 2GHz

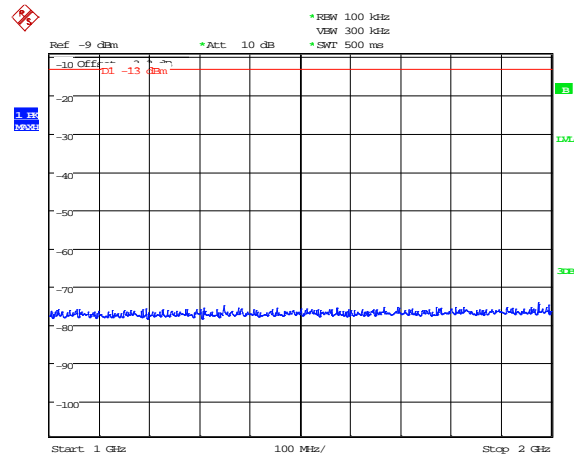

Date: 12.MAY.2015 17:35:38

Top 5 MHz band - Intermodulation close View

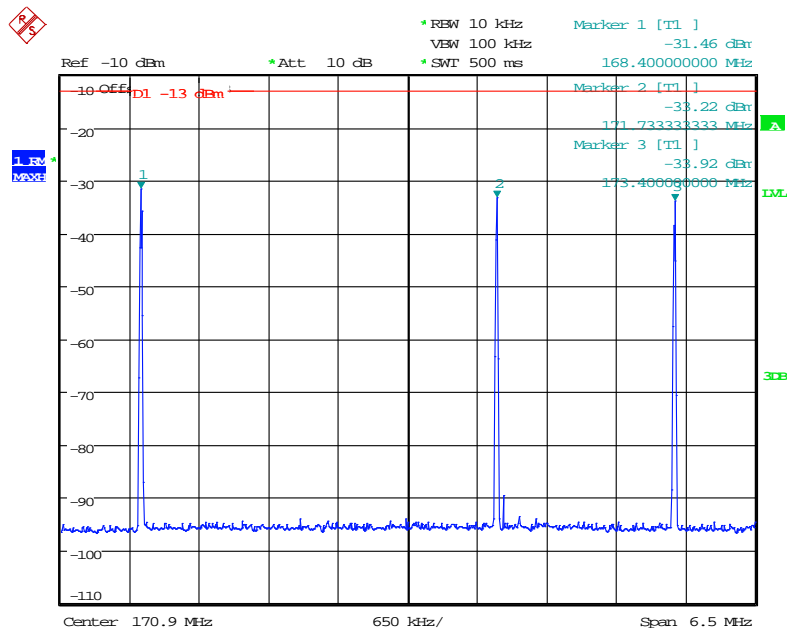

Date: 18.MAY.2015 14:10:33

9-150kHz

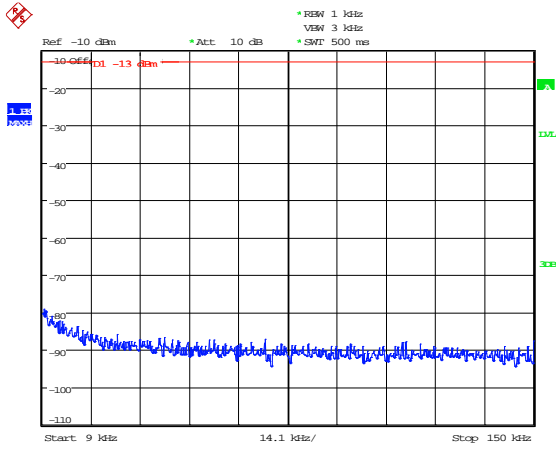

Date: 18.MAY.2015 14:11:30

150kHz – 30MHz

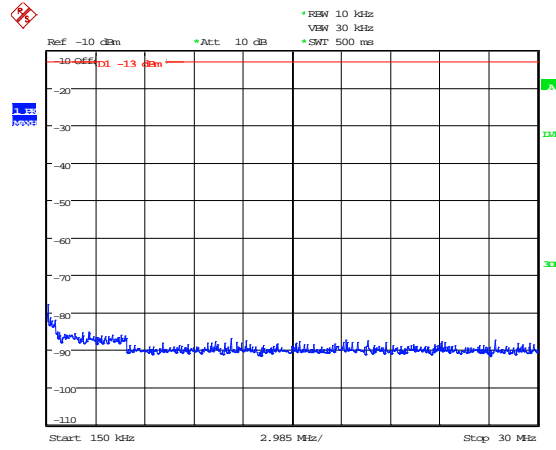

Date: 18.MAY.2015 14:11:54

30MHz – 1GHz

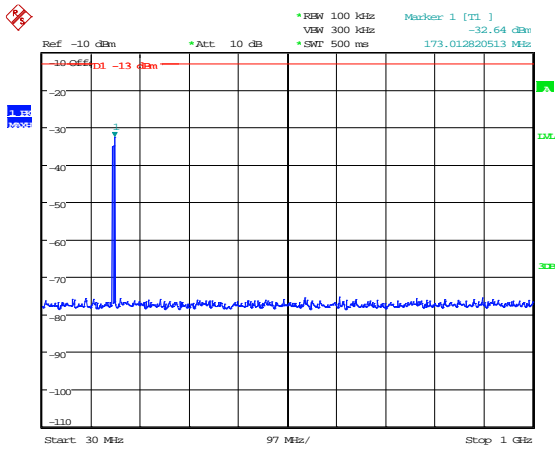

Date: 18.MAY.2015 14:12:18

1GHz – 2GHz

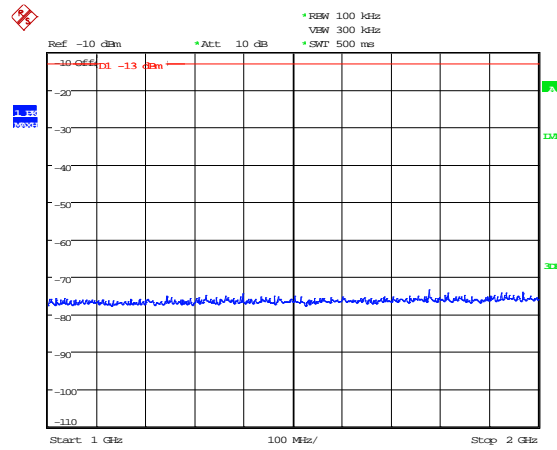

Date: 18.MAY.2015 14:13:04

A3 Amplifier Modulated Channel Test

Test Details:	
Measurement standard	Part 2.1049, Part 90.219(e)(4)(ii), 90.210(d)
EUT sample number	S01
Modification state	0
SE in test environment	None
SE isolated from EUT	None
EUT set up	Refer to Appendix C

Modulation Type	Frequency Of Operation Channel (MHz) Input		
	150.00625	161.7000	173.39375
FM 99% ocbw	10.09kHz	10.09kHz	10.09kHz
C4FM 99% ocbw	8.35kHz	8.35kHz	8.52kHz
CQPSK 99% ocbw	4.99kHz	4.93kHz	4.93kHz

Modulation Type	Frequency Of Operation Channel (MHz) output		
	150.00625	161.7000	173.39375
FM 99% ocbw	10.09kHz	10.09kHz	10.09kHz
C4FM 99% ocbw	8.35kHz	8.35kHz	8.52kHz
CQPSK 99% ocbw	4.99kHz	4.93kHz	4.93kHz

Industrial booster KDB 935210 D05 Signal Boosters 99% occupied bandwidth.

Test Details:	
Measurement standard	Part 2.1049, Part 90.219(e)(4)(ii), 90.210(d), 90.213(a)
EUT sample number	S01
Modification state	0
SE in test environment	None
SE isolated from EUT	None
EUT set up	Refer to Appendix C

Modulation Type	Frequency Of Operation Channel (MHz)		
	150.00625	161.7000	173.39375
Frequency	150.006250	161.700000	173.39375
ppm	0	0	0
5.0ppm			

Note: From minimum frequency stability table.

- 5) In the 150-174MHz band fixed and base stations, with a 12.5kHz channel bandwidth must Have a frequency stability of 2.5ppm
- 11) Paging transmitters operating on paging only frequencies must operate with frequency stability of 5ppm in the 150-174MHz band.

150.00625 FM Signal Generator and EUT

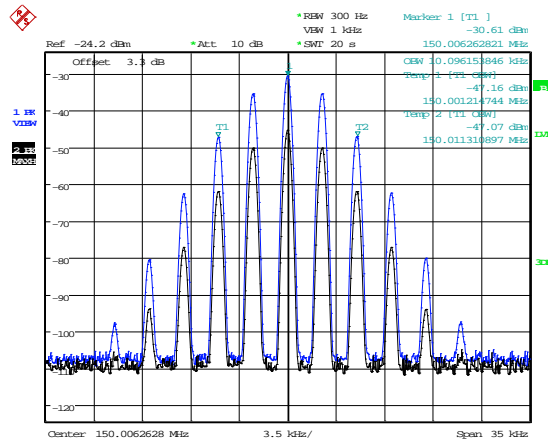

Date: 11.MAY.2015 16:51:42

150.00625 C4FM Signal Generator and EUT

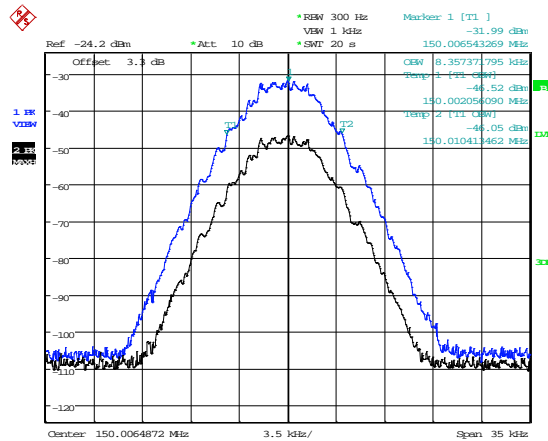

Date: 11.MAY.2015 16:38:27

150.00625 CQPSK Signal Generator and EUT

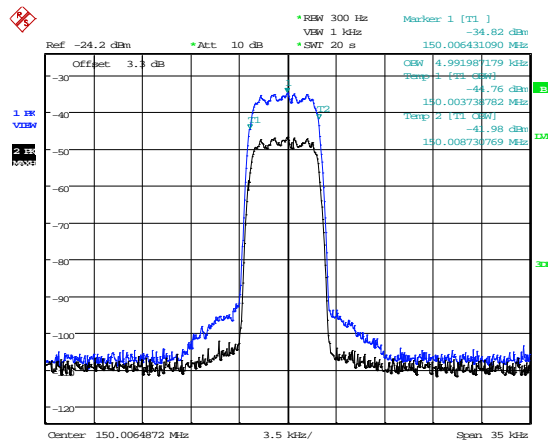

Date: 11.MAY.2015 16:43:04

The above plots depicting the output waveshape show no measurable distortion visible when compared to the input signal.

167.1MHz FM Signal Generator and EUT

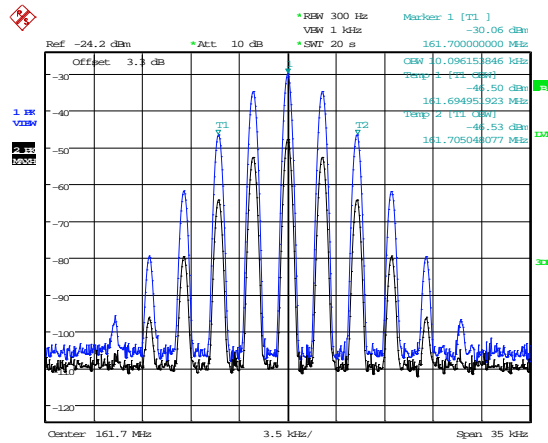

Date: 12.MAY.2015 15:42:37

167.1MHz C4FM Signal Generator and EUT

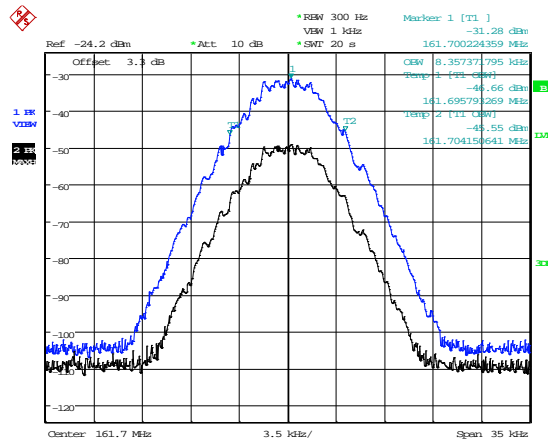

Date: 12.MAY.2015 15:47:34

167.1MHz CQPSK Signal Generator and EUT

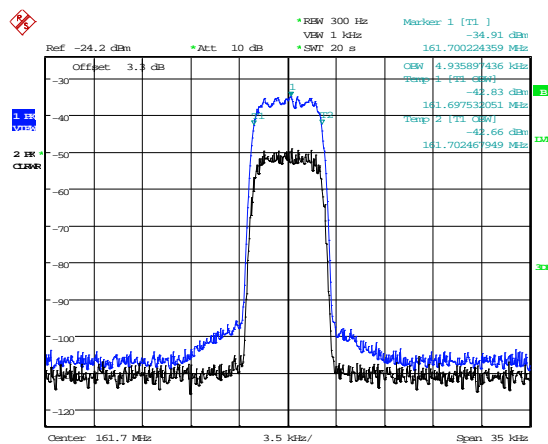

Date: 12.MAY.2015 16:09:40

The above plots depicting the output waveshape show no measurable distortion visible when compared to the input signal.

173.39375MHz FM Signal Generator and EUT

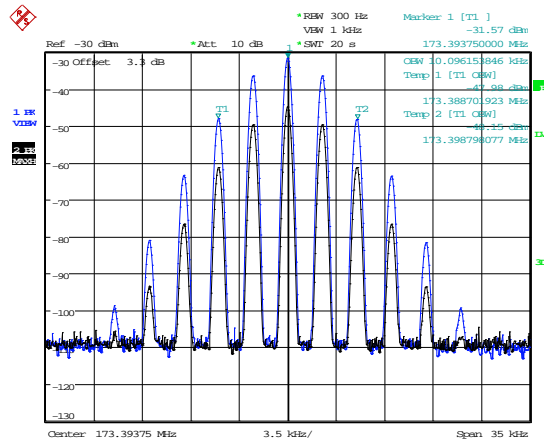

Date: 14.MAY.2015 17:14:56

173.39375MHz C4FM Signal Generator and EUT

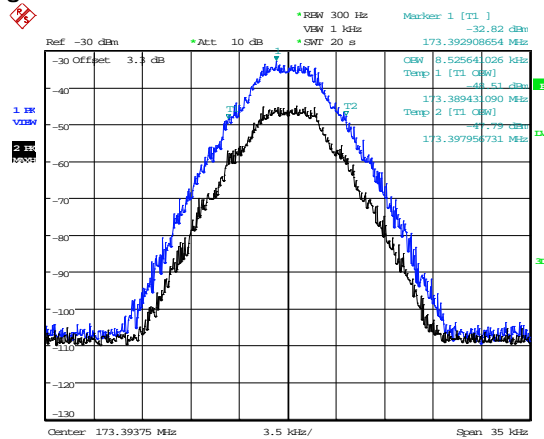

Date: 14.MAY.2015 17:22:40

173.39375MHz CQPSK Signal Generator and EUT

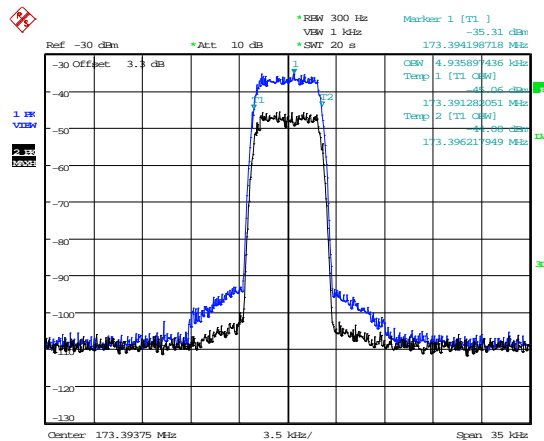

Date: 14.MAY.2015 17:27:13

The above plots depicting the output waveshape show no measurable distortion visible when compared to the input signal.

A4 Spurious Emissions at Antenna Terminals Less than 1MHz

Test Details:	
Measurement standard	Part 2.1053, 90.219(e)(3), 90.210(d)
EUT sample number	S01
Modification state	0
SE in test environment	None
SE isolated from EUT	None
EUT set up	Refer to Appendix C

Modulation Type	Bandedge	Carrier Frequency (MHz)	Max Level @ bandedge (dBm)
FM	Lower	N/A	#
C4FM	Lower	N/A	#
CQPSK	Lower	N/A	#

#: The conducted output power is lower than the limit of -13dBm, and therefore passes by default.

A5 Spurious Emissions at Antenna Terminals Greater than 1MHz

Test Details:	
Measurement standard	Part 2.1053, 90.219(e)(3)
EUT sample number	S01
Modification state	0
SE in test environment	None
SE isolated from EUT	None
EUT set up	Refer to Appendix C

Bottom Channel

Frequency Range (MHz)	Freq. of Emission (MHz)	Measured Level (dBm)	Attenuator & Cable Losses (dB)	Spurious Emission Level (dBm)	Limit dBm
9kHz - 2GHz	No Significant Emissions Within 10 dB of the Limit				-13

Middle Channel

Frequency Range (MHz)	Freq. of Emission (MHz)	Measured Level (dBm)	Attenuator & Cable Losses (dB)	Spurious Emission Level (dBm)	Limit dBm
9kHz - 2GHz	No Significant Emissions Within 10 dB of the Limit				-13

Top channel

Frequency Range (MHz)	Freq. of Emission (MHz)	Measured Level (dBm)	Attenuator & Cable Losses (dB)	Spurious Emission Level (dBm)	Limit dBm
9kHz - 2GHz	No Significant Emissions Within 10 dB of the Limit				-13

LIMIT =-13 dBm

Result

The EUT was found to comply with the limits

150.00625MHz Spurious Emissions at Antenna Terminals Greater than 1MHz

9-150kHz

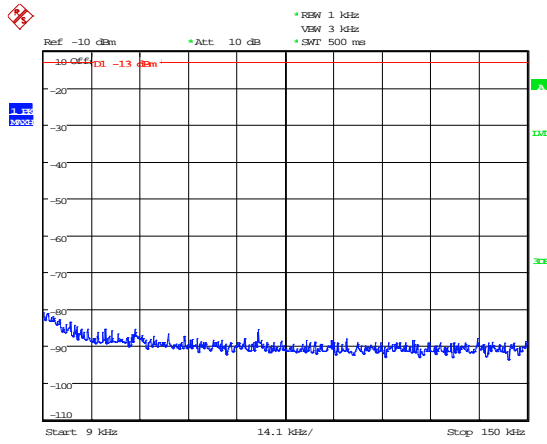

Date: 5.MAY.2015 17:03:18

150kHz – 30MHz

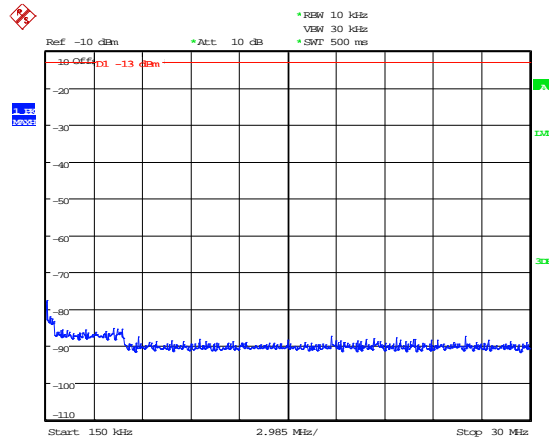

Date: 5.MAY.2015 17:03:59

30MHz – 1GHz

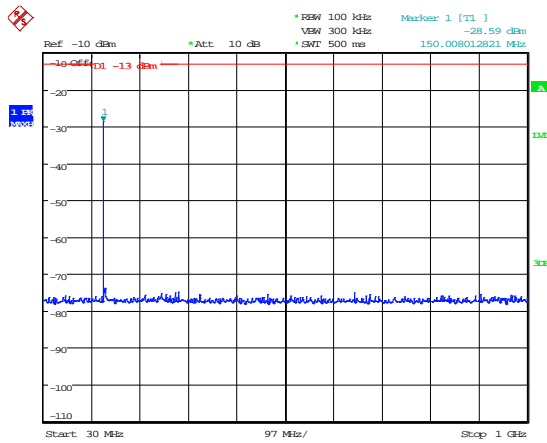

Date: 5.MAY.2015 17:02:17

1GHz – 2GHz

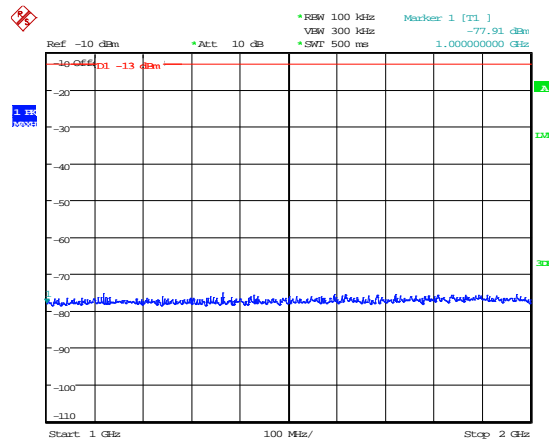

Date: 5.MAY.2015 17:02:38

161.7MHz Spurious Emissions at Antenna Terminals Greater than 1MHz

9-150kHz

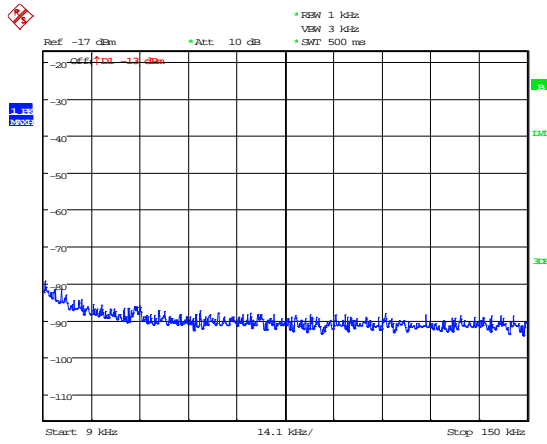

Date: 12.MAY.2015 17:00:22

150kHz – 30MHz

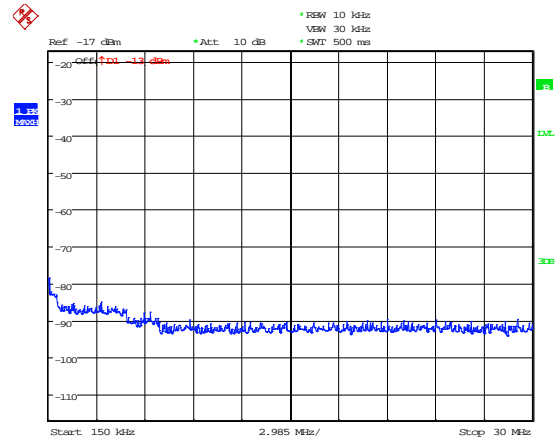

Date: 12.MAY.2015 17:01:02

30MHz – 1GHz

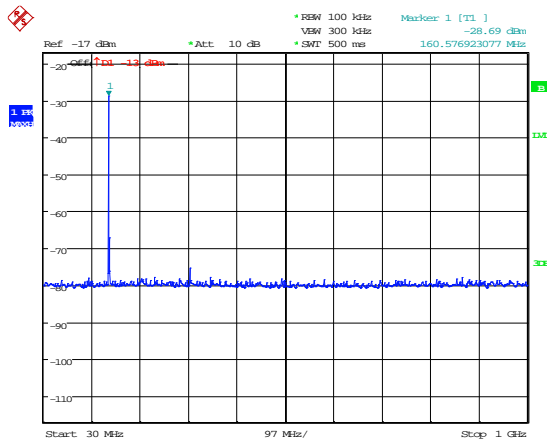

Date: 12.MAY.2015 16:59:24

1GHz – 2GHz

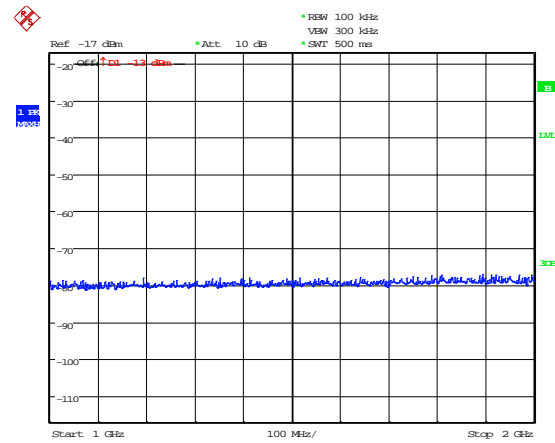

Date: 12.MAY.2015 16:59:45

173.39375MHz Spurious Emissions at Antenna Terminals Greater than 1MHz

9-150kHz

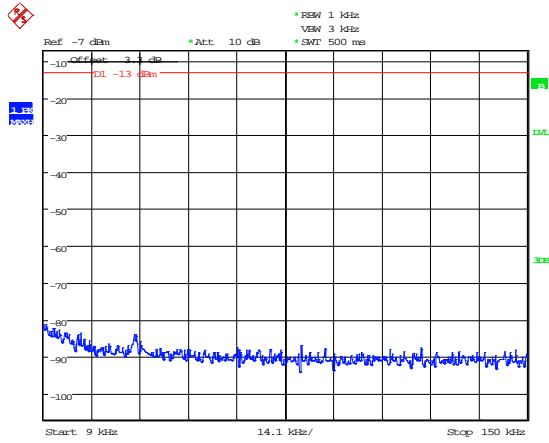

Date: 14.MAY.2015 17:04:42

150kHz – 30MHz

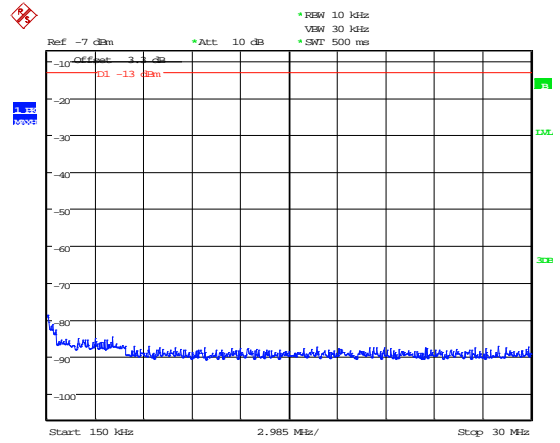

Date: 14.MAY.2015 17:05:13

30MHz – 1GHz

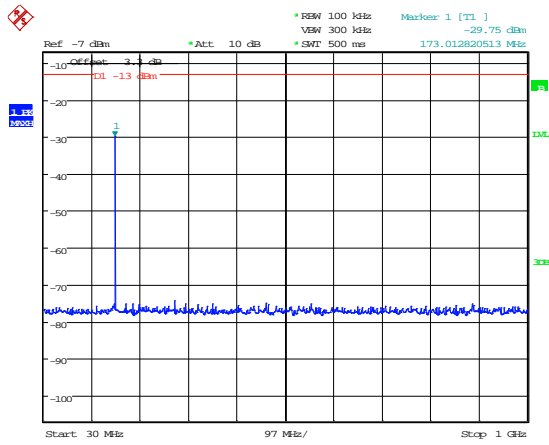

Date: 14.MAY.2015 17:05:47

1GHz – 2GHz

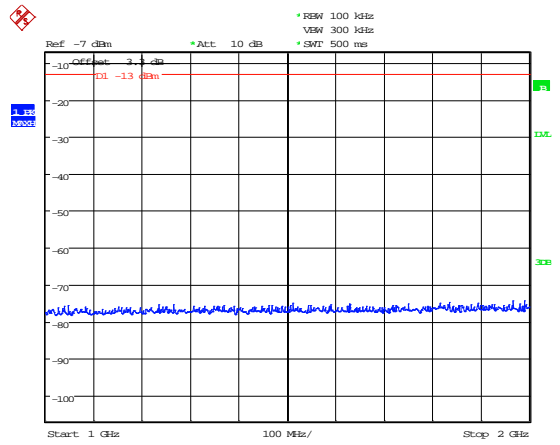

Date: 14.MAY.2015 17:06:04

A6 Noise at Antenna Terminals

Test Details:	
Measurement standard	90.219(e)(2), 90.219(e)(3), 90.219(d)(6)(ii)
EUT sample number	S01
Modification state	0
SE in test environment	None
SE isolated from EUT	None
EUT set up	Refer to Appendix C

Compliance with these levels will be deemed satisfaction of the good engineering practice requirement. In a 10 kHz measurement bandwidth:

- (1) the ERP of noise within the signal booster passband should not exceed -43dBm ;
- and
- (2) the ERP of noise on spectrum more than 1 MHz outside of the signal booster passband should not exceed -70 dBm .
 - (3) The noise figure of a signal booster must not exceed 9 dB in either direction

See appendix D for manufactures declaration on good engineering practice.

Test equipment used:-

TRaC No	Equipment Type	Equipment Description	Manufacturer	Last Cal Calibration	Calibration Period	Due For Calibration
UH405	FSU26	Spectrum Analyser	R&S	11/05/2015	12	11/05/2016
UH271	1.5m N type	Cable	TRaC	Cal in use		

The amplifier was connected to directly to the analyser via a cable. The analyser was tune to the selected open operating band of the analyser and the noise results recorded.

IN BAND AMPLIFIER NOISE – Lower 5 MHz Band

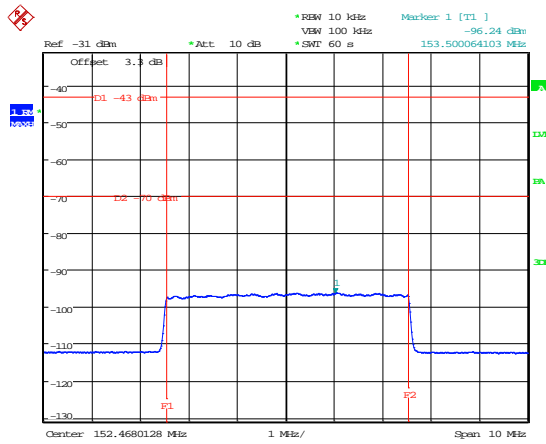

Date: 6.MAY.2015 14:28:53

IN BAND AMPLIFIER NOISE – Mid 5 MHz Band

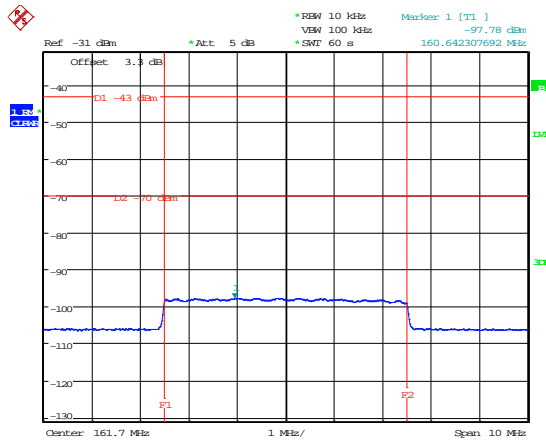

Date: 13.MAY.2015 10:13:13

IN BAND AMPLIFIER NOISE – Upper 5 MHz Band

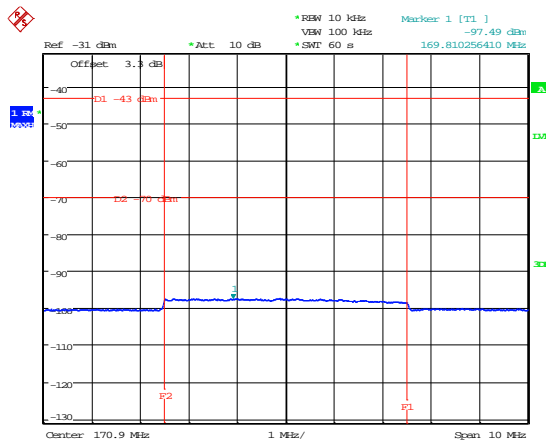

Date: 18.MAY.2015 14:21:18

A7 Radiated Electric Field Emissions

Preliminary scans were performed using a peak detector with the RBW = 100kHz. The radiated electric field emission test applies to all spurious and harmonic emissions. The EUT was set to transmit as required.

The following test site was used for final measurements as specified by the standard tested to:

3m open area test site : 3m alternative test site :

Test Details:	
Measurement standard	Title 47 of the CFR: Part90.219(e)(3)
Frequency range	30 MHz – 2 GHz
EUT sample number	S01
Modification state	0
SE in test environment	None
SE isolated from EUT	None
EUT set up	Refer to Appendix C

Bottom Frequency

FREQUENCY RANGE	FREQ. (MHz)	ERP/EIRP (dBm)	LIMIT (dBm)
30MHz - 2GHz	No Significant Emissions Within 10 dB of the Limit		-13

Middle Frequency

FREQUENCY RANGE	FREQ. (MHz)	ERP/EIRP (dBm)	LIMIT (dBm)
30MHz - 2GHz	No Significant Emissions Within 10 dB of the Limit		-13

Top Frequency

FREQUENCY RANGE	FREQ. (MHz)	ERP/EIRP (dBm)	LIMIT (dBm)
30MHz - 2GHz	No Significant Emissions Within 10 dB of the Limit		-13

Result

The EUT was found to comply with the limits

Notes:

1. Emissions Checked up to 10 times Fc.
2. The unit was mounted on a turntable and rotated through 360° to find the worst case emission.
3. For Frequencies below 1 GHz, RBW = 120 kHz, testing was performed with CISPR16 compliant test receiver with Pk detector. Above 1 GHz tests were performed using a spectrum analyser using the following settings:

Peak Detector RBW = 1MHz; VBW = ≥RBW

4. Limit is determined as follows.

LIMIT = -13 dBm

The upper and lower frequency of the measurement range was decided according to 47 CFR Part 2.1057.

- (a) Where results have been measured at one distance, and a signal level displayed at another, the results have been extrapolated using the following formula:

$$\text{Extrapolation (dB)} = 20 \log_{10} \left(\frac{\text{measurement distance}}{\text{specification distance}} \right)$$

- (b) The levels may have been rounded for display purposes.
- (c) The following table summarises the effect of the EUT operating mode, internal configuration and arrangement of cables / samples on the measured emission levels:
- (d) Any spurious emission found to be within 20dB of the limit on the pre scans, the final measurement was performed using the antenna substitution method. This value was used against the limit.

	See (i)	See (ii)	See (iii)	See (iv)
Effect of EUT operating mode on emission levels	✓			
Effect of EUT internal configuration on emission levels	✓			
Effect of Position of EUT cables & samples on emission levels	✓			
(i) Parameter defined by standard and / or single possible, refer to Appendix D				
(ii) Parameter defined by client and / or single possible, refer to Appendix D				
(iii) Parameter had a negligible effect on emission levels, refer to Appendix D				
(iv) Worst case determined by initial measurement, refer to Appendix D				

150.00625MHz Radiated Electric Field Emissions

30MHz – 1GHz

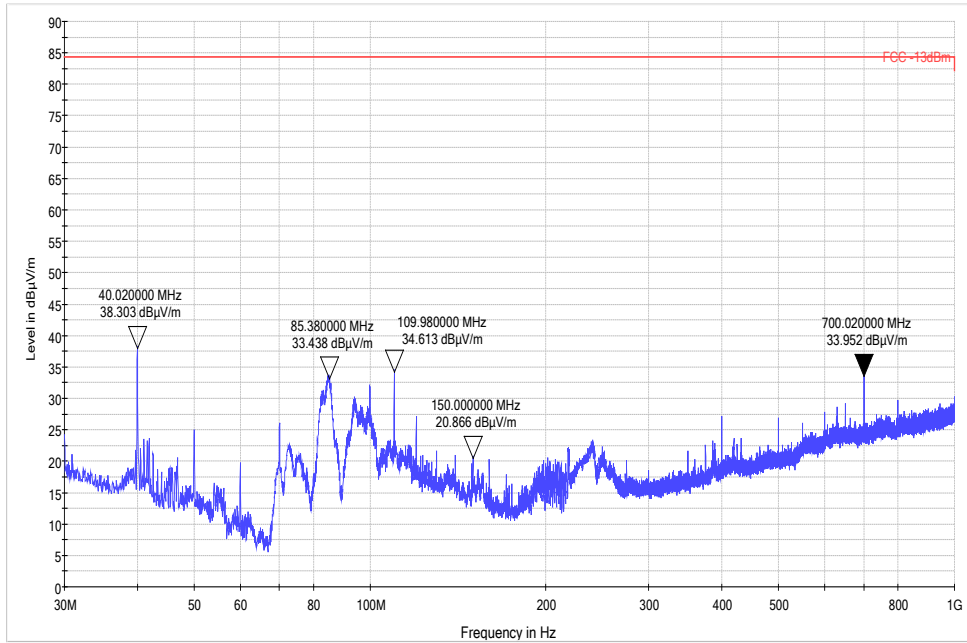

1GHz – 2GHz

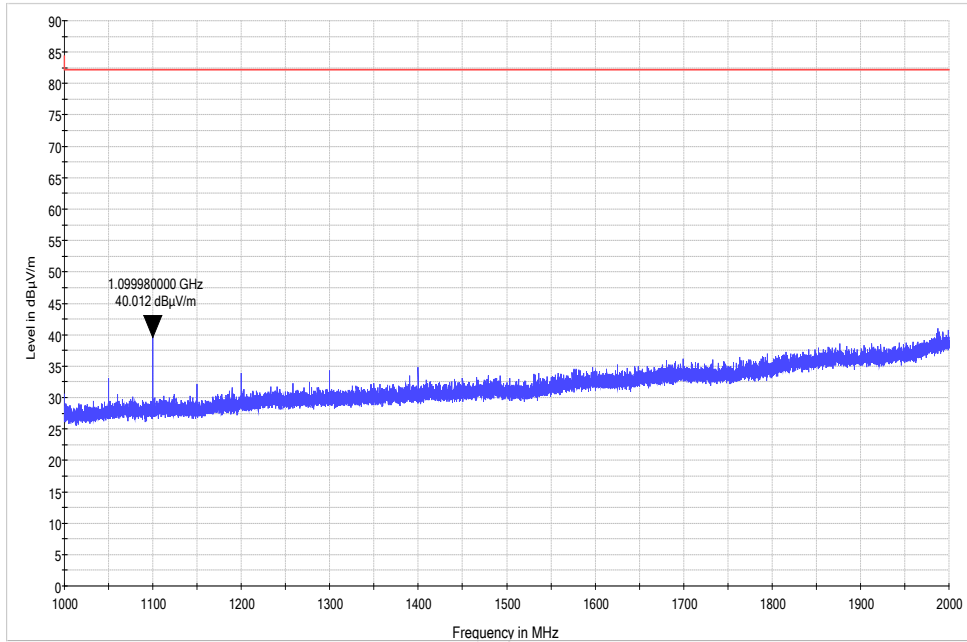

161.7MHz Radiated Electric Field Emissions

30MHz – 1GHz

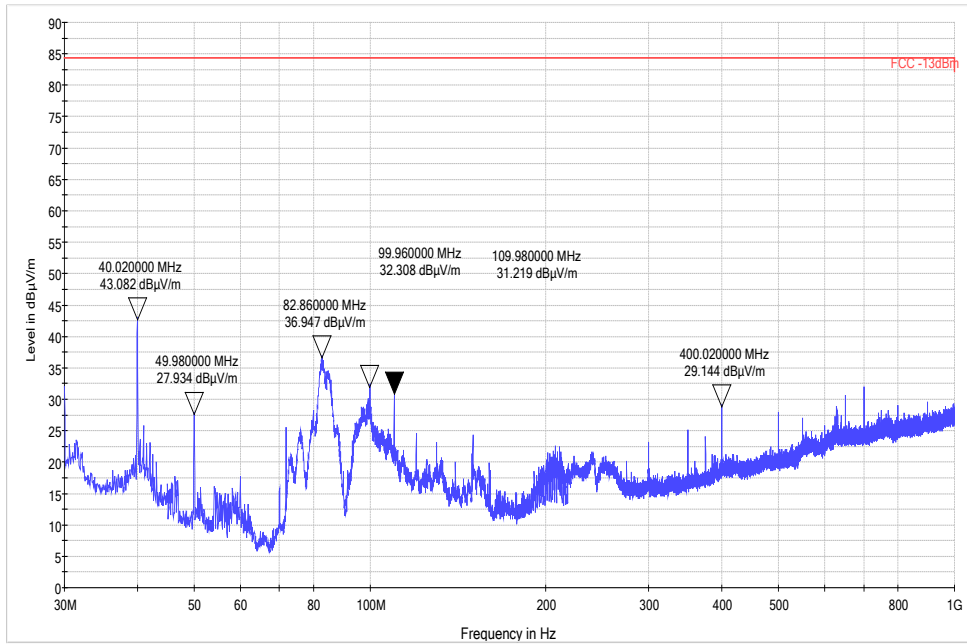

1GHz - 2GHz

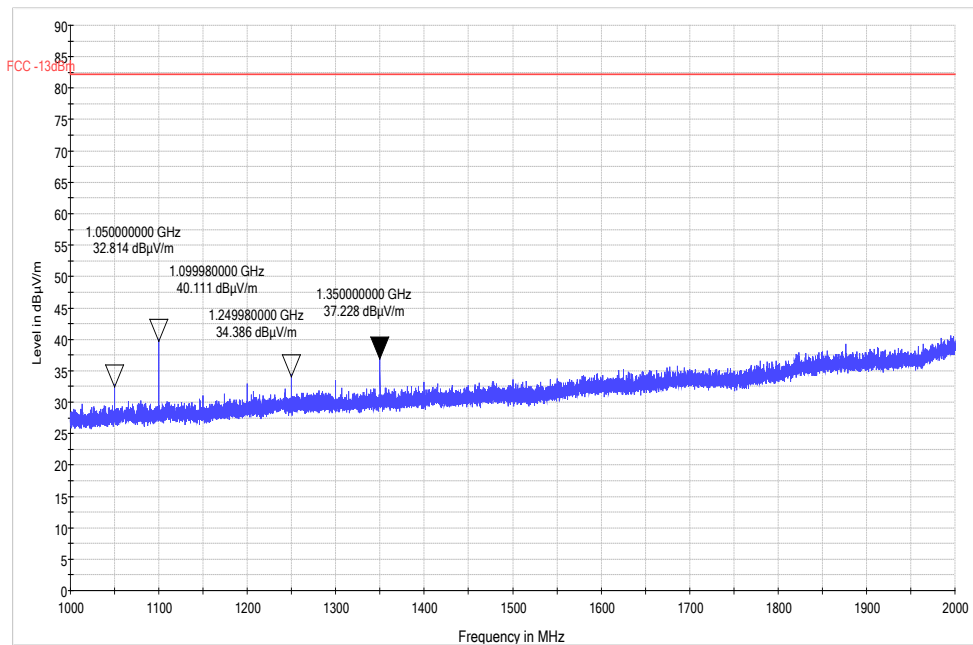

173.39375MHz Radiated Electric Field Emissions

30MHz – 1GHz

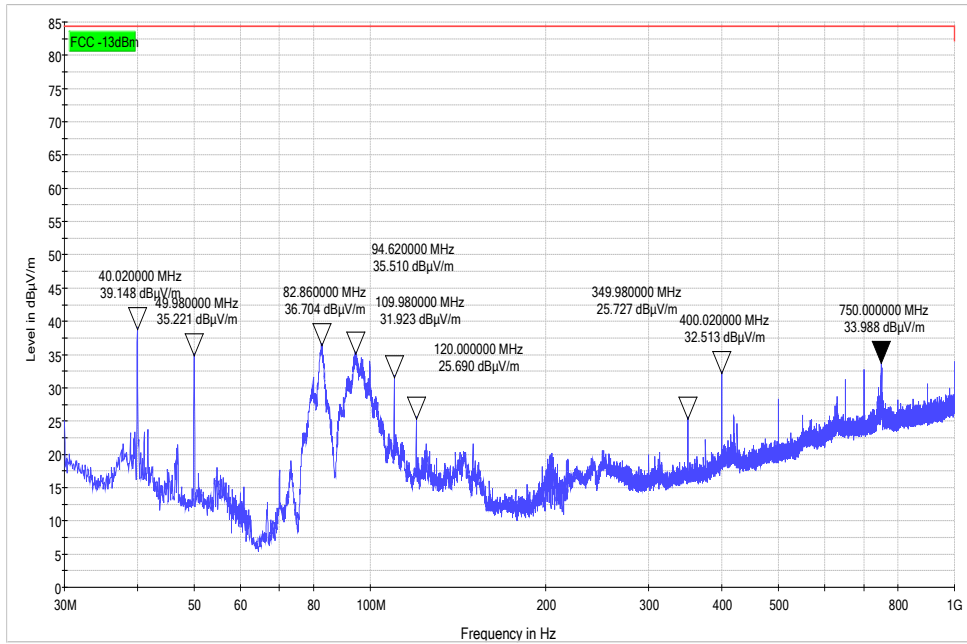

1GHz – 2GHz

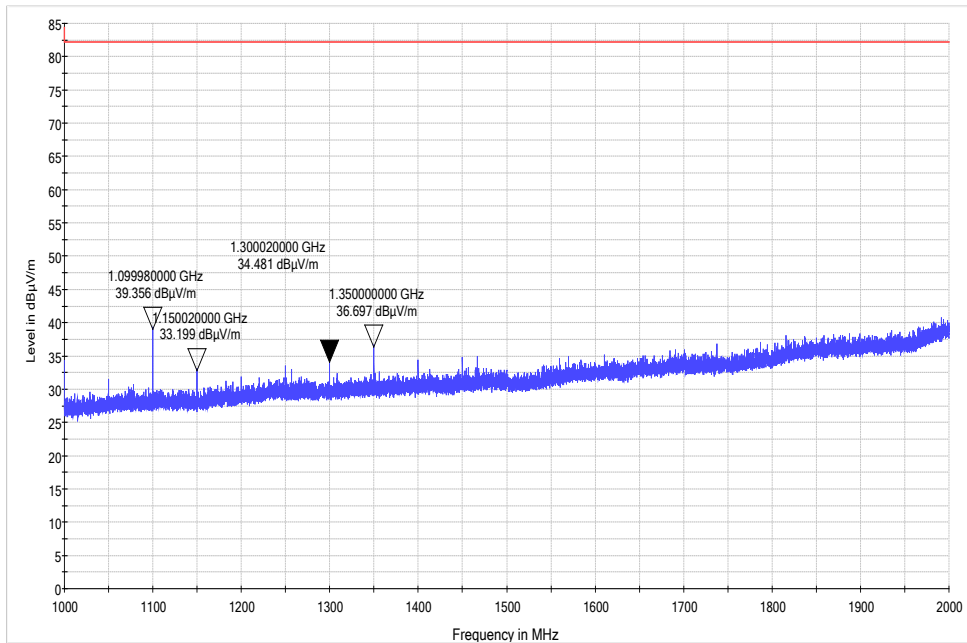

A8 Passband Gain & Bandwidth

Test Details:	
Measurement standard	D.3 Policies + Procedures (k) of KDB 935210 D02 Signal Boosters Certification v02
EUT sample number	S01
Modification state	0
SE in test environment	None
SE isolated from EUT	None
EUT set up	Refer to Appendix C

Frequency MHz	Fl MHz	Fh MHz	20 dB Bandwidth
152.5MHz	149.862500	155.140000	5.27MHz
161.7MHz	159.055000	164.345000	5.29MHz
170.9MHz	168.245000	173.545000	5.30MHz

1. See below for plots showing passband gain & bandwidth

With the aid of a CW Swept signal generator and spectrum analyser, the bandwidth and frequency response of the open channel (i.e. at the point where the gain has fallen by 20 dB) is measured. This measurement shows the gain-versus-frequency response of the open channel from the midband frequency f_0 of the channel up to at least $f_0 + 250\%$ of the 20 dB bandwidth.

Lower 5 MHz band – 152.5MHz

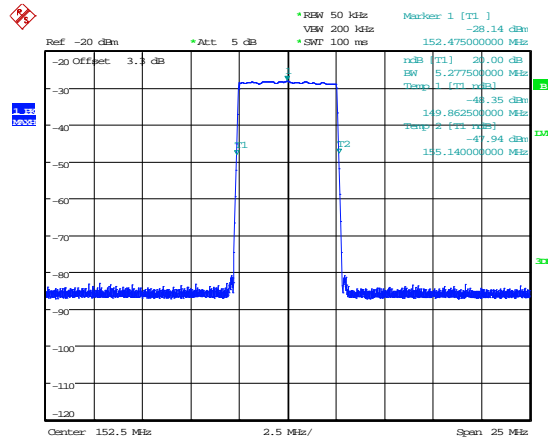

Date: 11.MAY.2015 14:42:56

Mid 5 MHz band – 161.7MHz

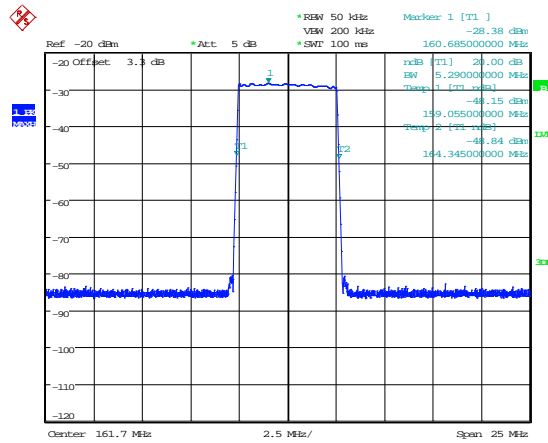

Date: 13.MAY.2015 12:35:43

Higher 5 MHz band – 170.9MHz

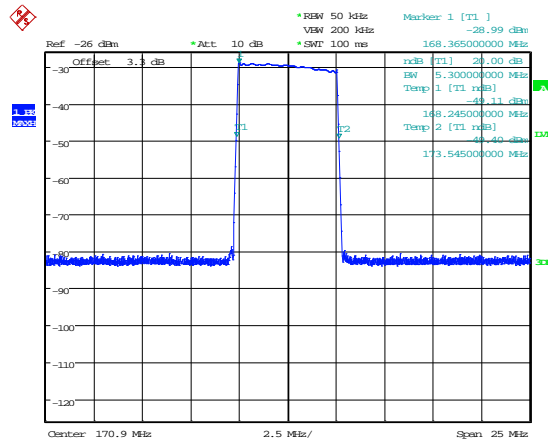

Date: 18.MAY.2015 13:56:44

Appendix B:**Downlink Formal Emission Test Results**

Abbreviations used in the tables in this appendix:

Spec	: Specification	ALSR	: Absorber Lined Screened Room
Mod	: Modification	OATS	: Open Area Test Site
EUT	: Equipment Under Test	ATS	: Alternative Test Site
SE	: Support Equipment	Ref	: Reference
L	: Live Power Line	Freq	: Frequency
N	: Neutral Power Line	MD	: Measurement Distance
E	: Earth Power Line	SD	: Spec Distance
Pk	: Peak Detector	Pol	: Polarisation
QP	: Quasi-Peak Detector	H	: Horizontal Polarisation
Av	: Average Detector	V	: Vertical Polarisation
CDN	: Coupling & decoupling network		

B1 RF Gain and Output Power

Test Details:	
Measurement standard	Part 2.1046, Part 90.219(e)(1)
EUT sample number	S01
Modification state	0
SE in test environment	None
SE isolated from EUT	None
EUT set up	Refer to Appendix C

Frequency MHz	Signal Generator input level dBm	Input Cable Loss dB	Level at Spectrum Analyser dBm	Output Cable & Attenuator loss dB	Gain dB	Conducted Output Power dBm	Gain after 10dB input level increase dB
150.00625	1.27	0.10	-6.81	40.5	32.52	33.69	22.40
161.70000	0.57	0.10	-6.56	40.5	33.47	33.94	23.39
173.39375	2.65	0.10	-8.98	40.5	28.97	31.52	17.89

Notes: 1.The signal generator input was increased by 10dBs and the level of the output signal remeasured.

Industrial booster requirements KDB 935210 D05 the EUT was tested at compression and 10dB into compression to show AGC operation.

B2 Amplifier Intermodulation Spurious Emissions

Test Details:	
Measurement standard	Part 2.1053, 90.219(e)(3)
EUT sample number	S01
Modification state	0
SE in test environment	None
SE isolated from EUT	None
EUT set up	Refer to Appendix C

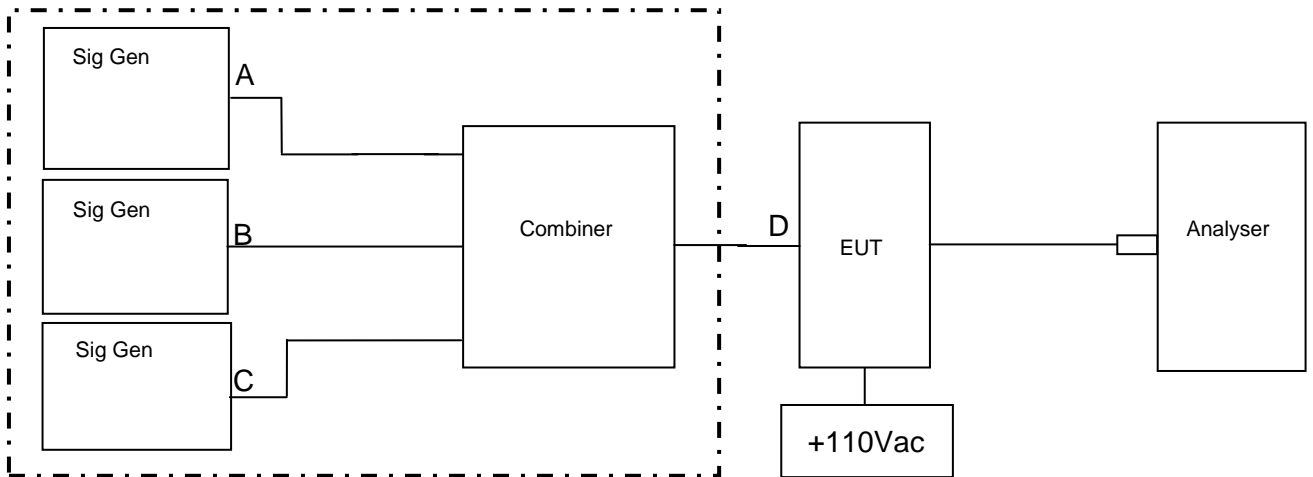

*Signal Generator B was varied in frequency to check if intermodulation products were produced.

RF Input Frequency (MHz)		Highest Intermodulation Product Level (dBm)		Limit (dBm)
Lower 5 MHz Band				
150.00625	*	154.99375	-18.31 @ 151.6688MHz	-30
Mid 5 MHz Band				
159.20625	*	164.19375	-16.83 @ 160.6688MHz	-30
Upper 5 MHz Band				
169.00625	*	173.39375	-19.48 @ 170.0669MHz	-30

Sweep data is shown on the next page:

Results

See appendix D for manufacturer's declaration on good engineering practice.

See plots below

As per Annex .3 Policies + Procedures (k) of KDB 935210 D02 Signal Boosters Certification v03 the EUT was tested at compression and 10dB into compression to show AGC operation, worst case results taken.

Lower 5 MHz band - Intermodulation close View

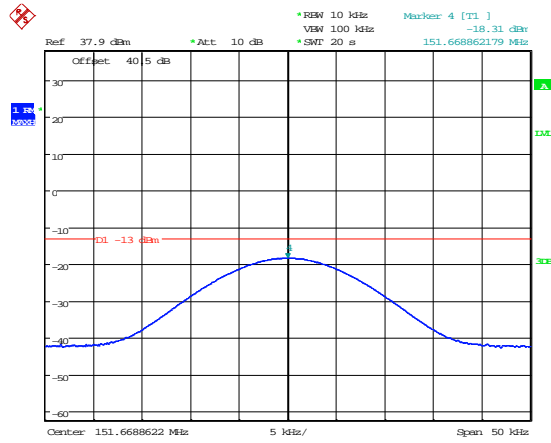

Date: 18.MAY.2015 16:17:37

Intermodulation wide View

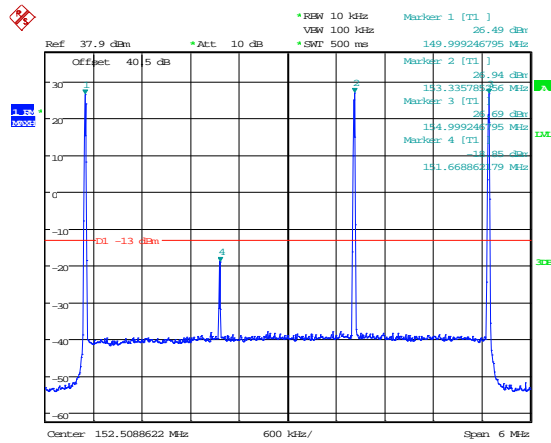

Date: 18.MAY.2015 16:18:43

Intermodulation wide View

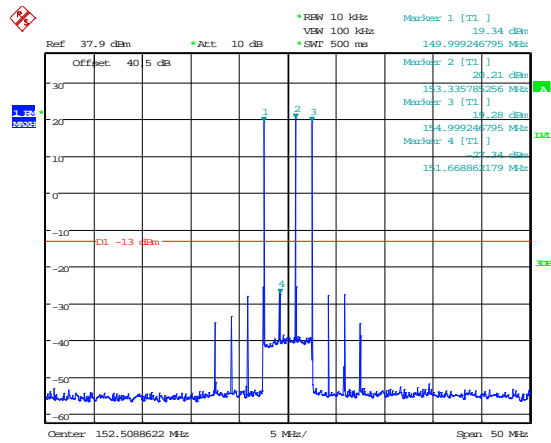

Date: 18.MAY.2015 16:19:04

9-150kHz

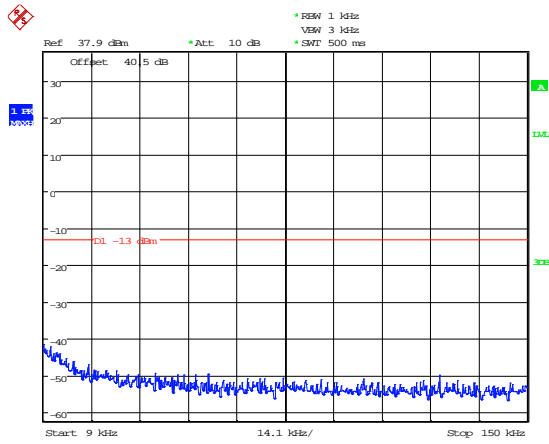

Date: 18.MAY.2015 16:21:15

150kHz – 30MHz

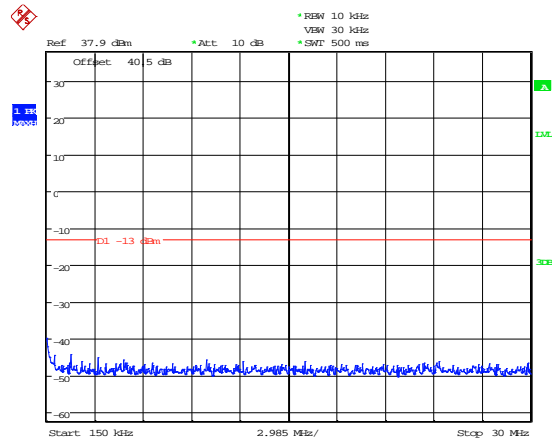

Date: 18.MAY.2015 16:21:49

30MHz – 1GHz

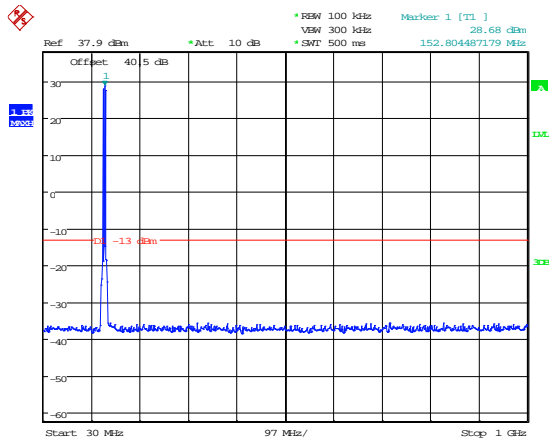

Date: 18.MAY.2015 16:22:21

1GHz – 2GHz

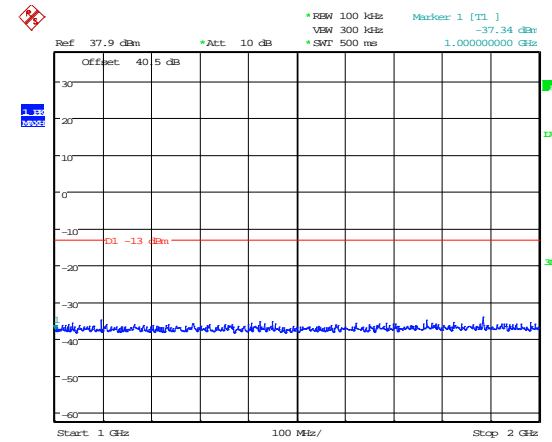

Date: 18.MAY.2015 16:22:44

Mid 5 MHz band - Intermodulation close View

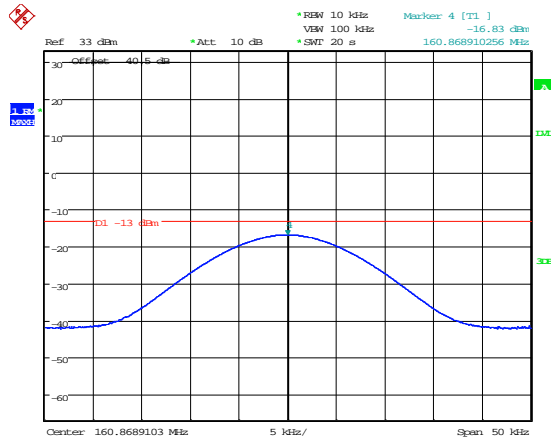

Date: 18.MAY.2015 15:13:57

Mid 5 MHz band - Intermodulation wide View

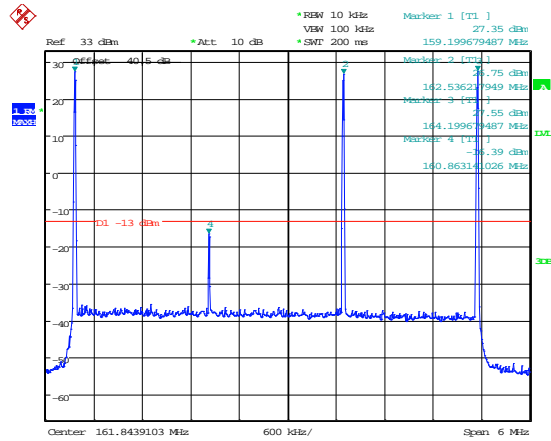

Date: 18.MAY.2015 15:15:24

Mid 5 MHz band - Intermodulation wide View

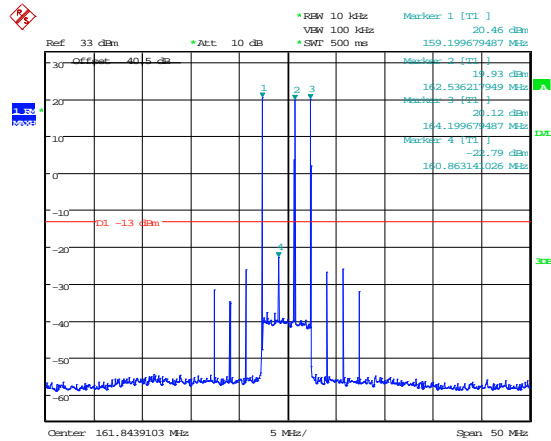

Date: 18.MAY.2015 15:15:50

9-150kHz

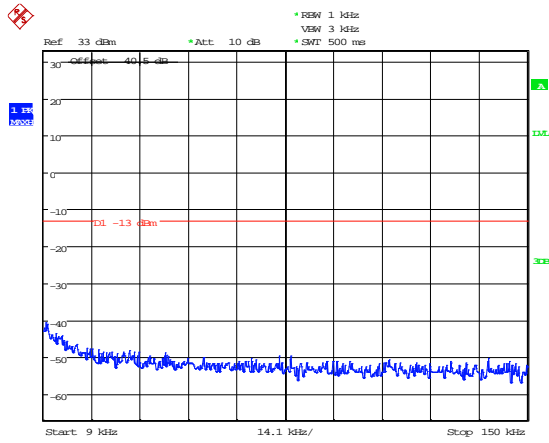

Date: 18.MAY.2015 15:16:34

150kHz – 30MHz

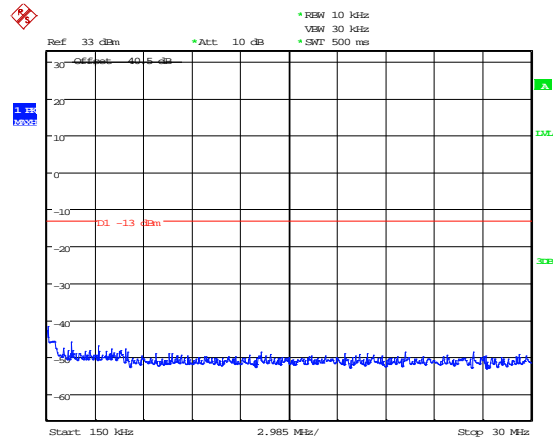

Date: 18.MAY.2015 15:16:57

30MHz – 1GHz

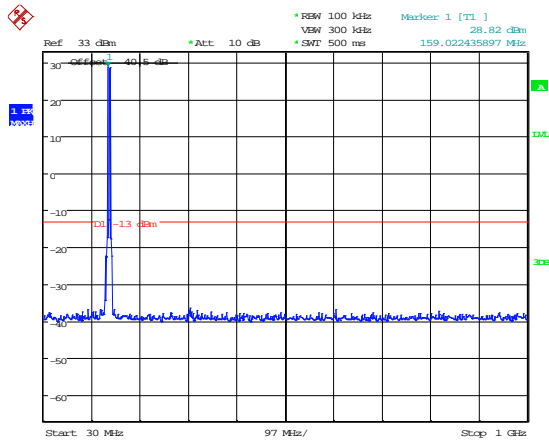

Date: 18.MAY.2015 15:17:25

1GHz – 2GHz

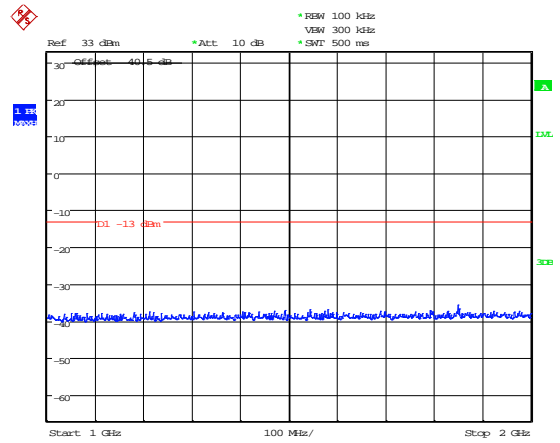

Date: 18.MAY.2015 15:17:43

Top 5 MHz band - Intermodulation close View

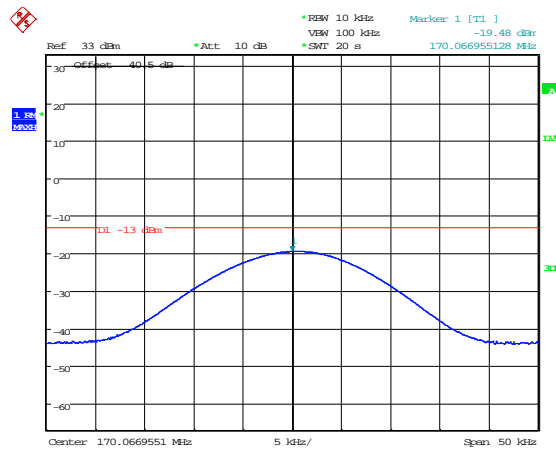

Date: 18.MAY.2015 10:57:56

Top 5 MHz band - Intermodulation wide View

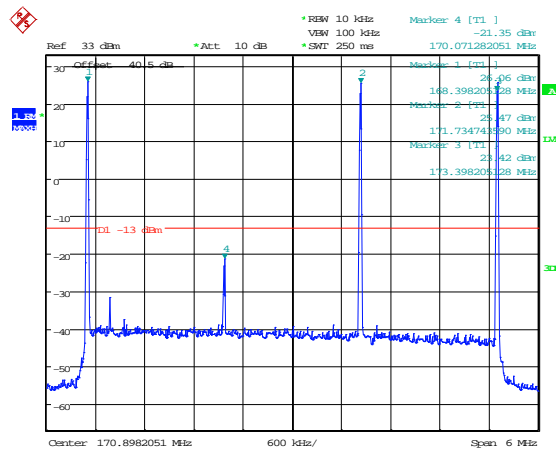

Date: 18.MAY.2015 10:55:45

Top 5 MHz band - Intermodulation wide View

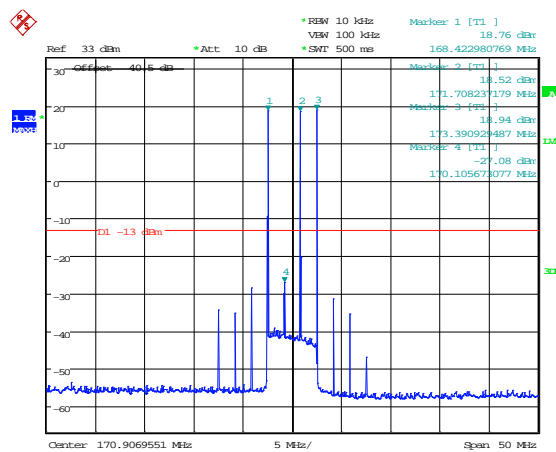

Date: 18.MAY.2015 10:59:08

9-150kHz

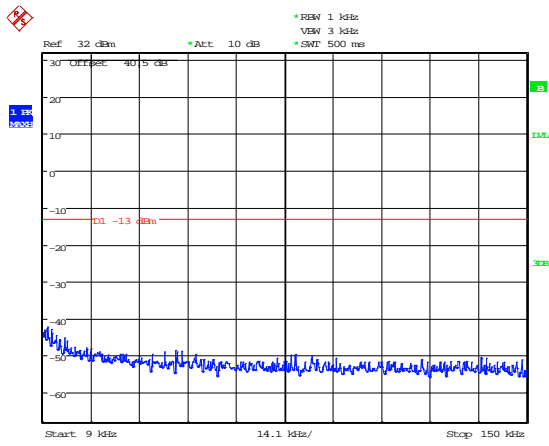

Date: 14.MAY.2015 17:50:55

150kHz – 30MHz

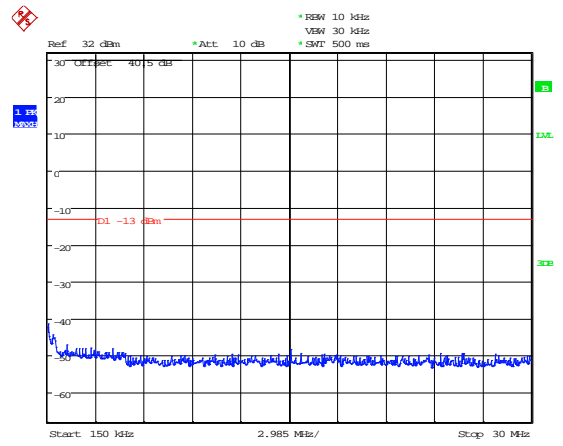

Date: 14.MAY.2015 17:51:29

30MHz – 1GHz

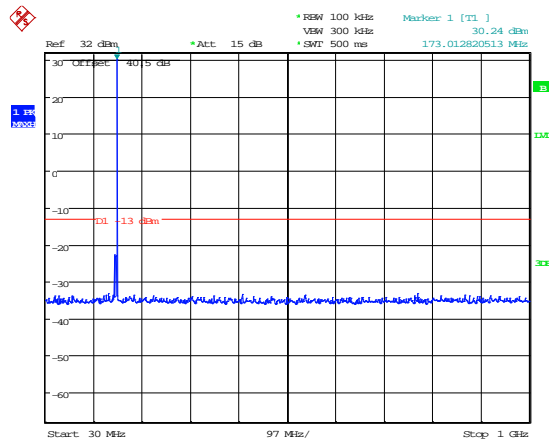

Date: 14.MAY.2015 17:50:01

1GHz – 2GHz

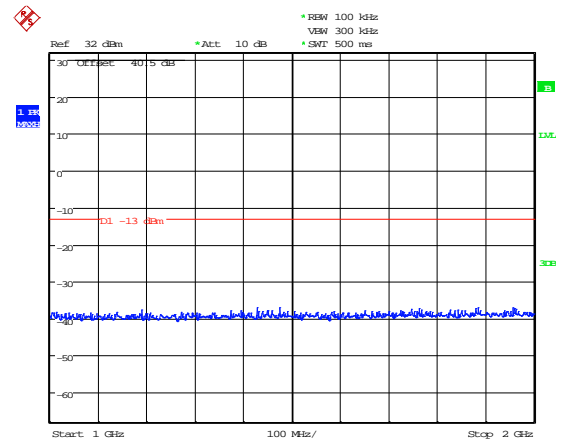

Date: 14.MAY.2015 17:50:27

B3 Amplifier Modulated Channel Test

Test Details:	
Measurement standard	Part 90.219(a), Part 90.219(e)(4)(ii), 90.210(d)
EUT sample number	S01
Modification state	0
SE in test environment	None
SE isolated from EUT	None
EUT set up	Refer to Appendix C

Modulation Type	Frequency Of Operation Channel (MHz) Input		
	150.00625	161.7000	173.39375
FM	10.09kHz	10.09kHz	10.09kHz
C4FM	8.30kHz	8.35kHz	8.58kHz
CQPSK	4.93kHz	4.93kHz	4.99kHz

Modulation Type	Frequency Of Operation Channel (MHz) Output		
	150.00625	161.7000	173.39375
FM	10.09kHz	10.09kHz	10.09kHz
C4FM	8.30kHz	8.35kHz	8.58kHz
CQPSK	4.93kHz	4.93kHz	4.99kHz

Industrial booster KDB 935210 D05 Signal Boosters 99% occupied bandwidth.

Test Details:	
Measurement standard	Part 2.1049, Part 90.219(e)(4)(ii), 90.210(d), 90.213(a)
EUT sample number	S01
Modification state	0
SE in test environment	None
SE isolated from EUT	None
EUT set up	Refer to Appendix C

Note: From minimum frequency stability table.

5) In the 150-174MHz band fixed and base stations, with a 12.5kHz channel bandwidth must Have a frequency stability of 2.5ppm

11) Paging transmitters operating on paging only frequencies must operate with frequency stability of 5ppm in the 150-174MHz band.

Modulation Type	Frequency Of Operation Channel (MHz)		
	150.00625	161.7000	173.39375
Frequency	150.006250	161.700000	173.39375
ppm	0	0	0
5.0ppm			

150.00625MHz FM Signal Generator and EUT

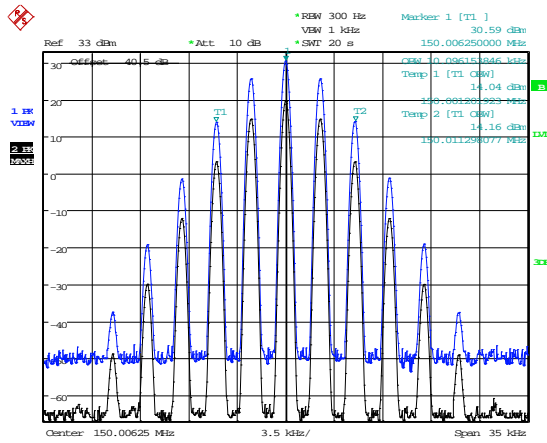

Date: 11.MAY.2015 16:09:12

150.00625MHz C4FM Signal Generator and EUT

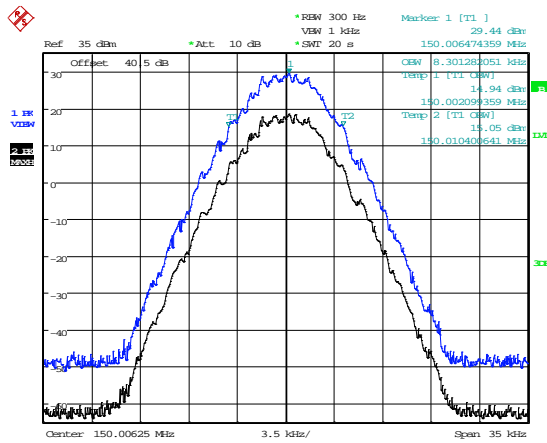

Date: 11.MAY.2015 16:00:31

150.00625MHz CQPSK Signal Generator and EUT

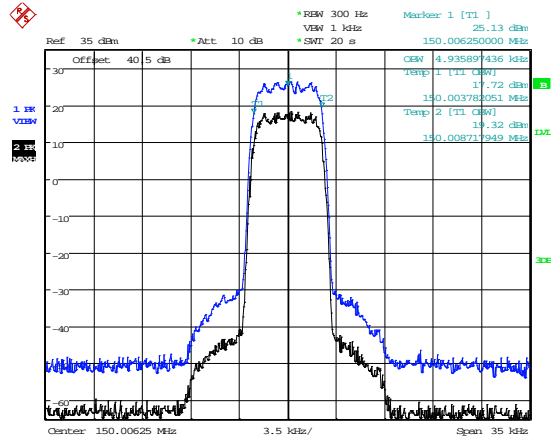

Date: 11.MAY.2015 15:55:46

The above plots depicting the output wavelshape show no measurable distortion visible when compared to the input signal.

161.7MHz FM Signal Generator and EUT

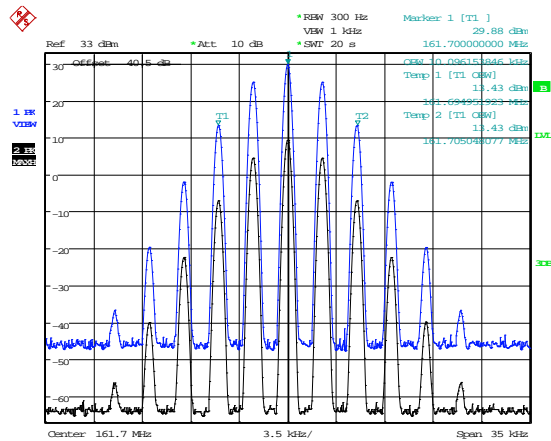

Date: 12.MAY.2015 16:46:19

161.7MHz C4FM Signal Generator and EUT

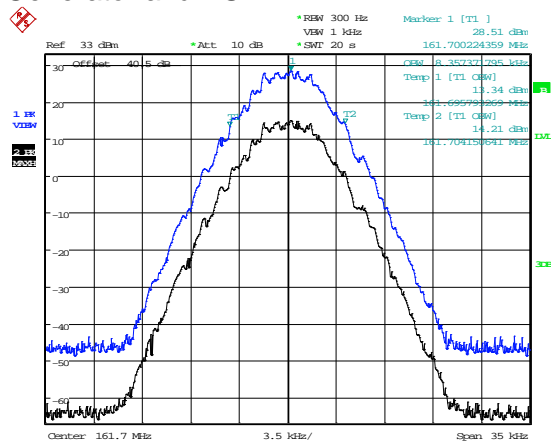

Date: 12.MAY.2015 16:26:27

161.7MHz CQPSK Signal Generator and EUT

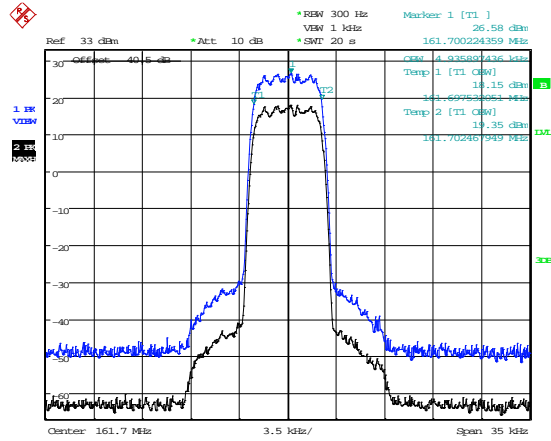

Date: 12.MAY.2015 16:18:50

The above plots depicting the output wavelshape show no measurable distortion visible when compared to the input signal.
173.39375MHz FM Signal Generator and EUT

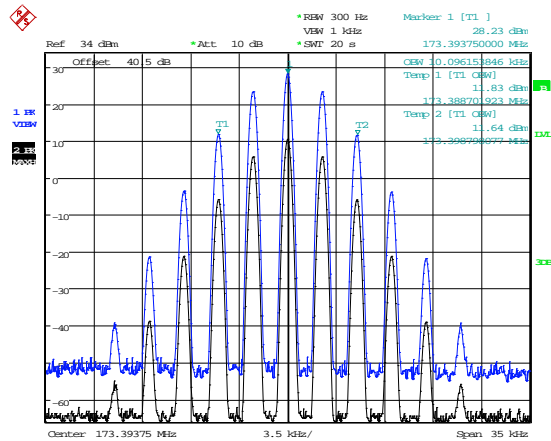

Date: 14.MAY.2015 17:44:24

173.39375MHz FM C4FM Signal Generator and EUT

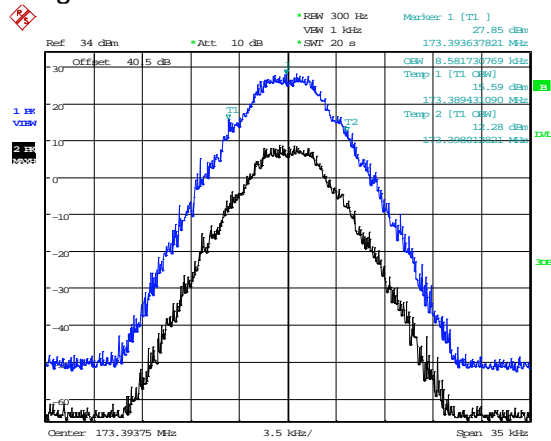

Date: 14.MAY.2015 17:40:58

173.39375MHz FM CQPSK Signal Generator and EUT

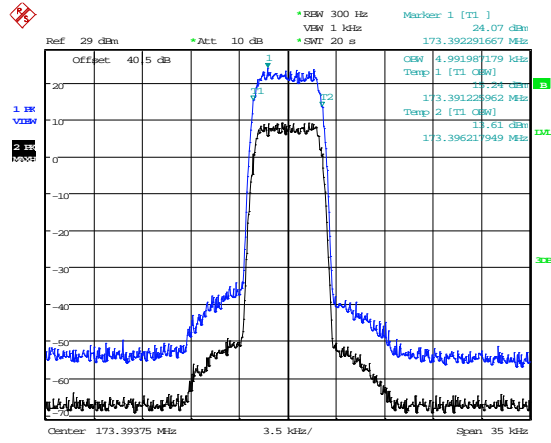

Date: 14.MAY.2015 17:34:57

The above plots depicting the output wavelshape show no measurable distortion visible when compared to the input signal.

B4 Spurious Emissions at Antenna Terminals Less than 1MHz

Test Details:	
Measurement standard	Part 2.1053, 90.219(e)(3), 90.210(d)
EUT sample number	S01
Modification state	0
SE in test environment	None
SE isolated from EUT	None
EUT set up	Refer to Appendix C

Modulation Type	Bandedge	Carrier Frequency (MHz)	Max Level @ bandedge (dBm)
FM	Lower	150.00625	-15.77
C4FM	Lower	150.00700	-15.80
CQPSK	Lower	150.00380	-15.54

Modulation Type	Bandedge	Carrier Frequency (MHz)	Max Level @ bandedge (dBm)
FM	Higher	173.991600	-16.03
C4FM	Higher	173.992600	-19.96
CQPSK	Higher	173.996150	-16.07

FM Signal – Lower Bandedge

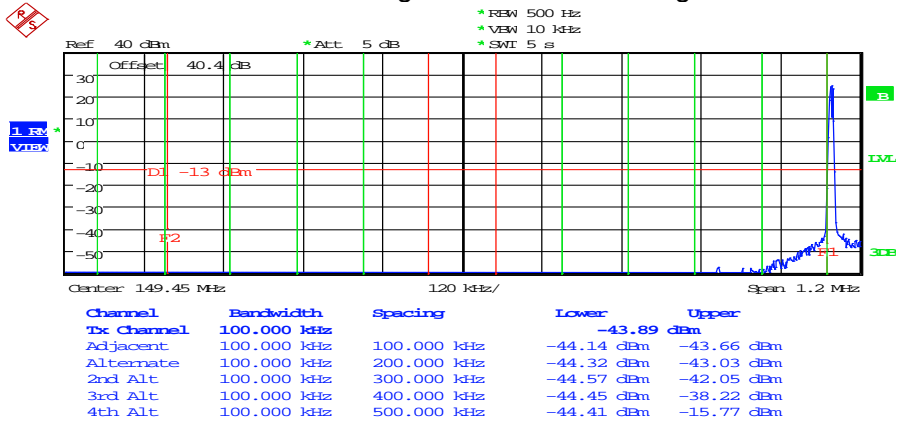

C4FM Signal – Lower Bandedge



CQPSK Signal – Lower Bandedge

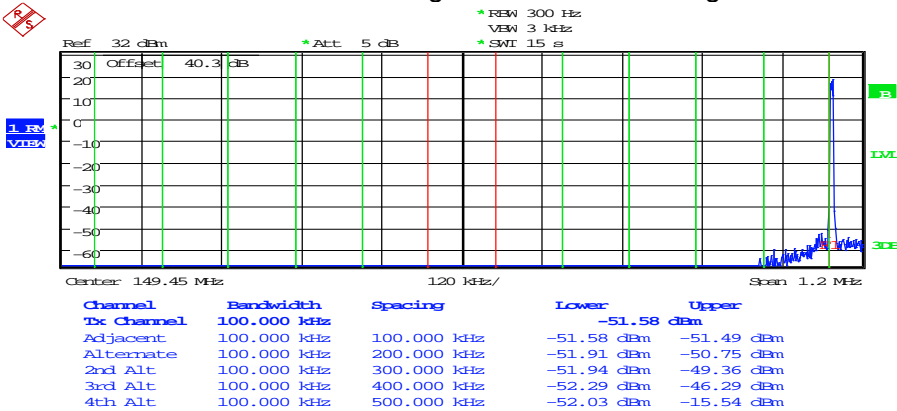

FM Signal – Higher Bandedge

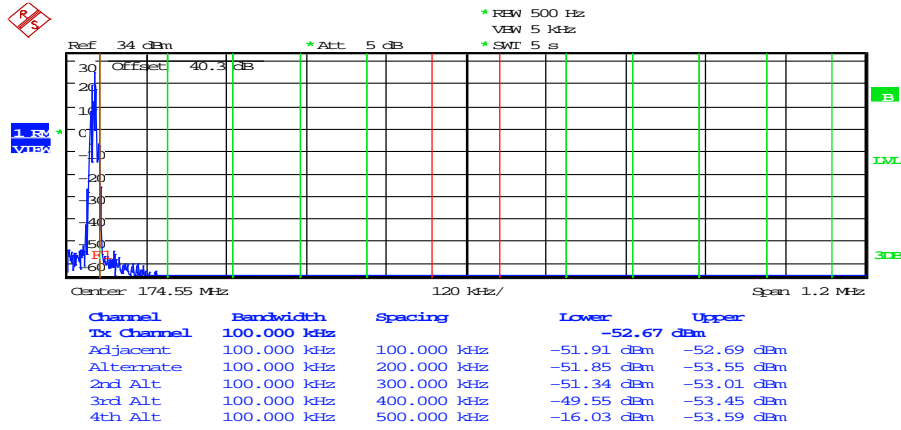

C4FM Signal – Higher Bandedge

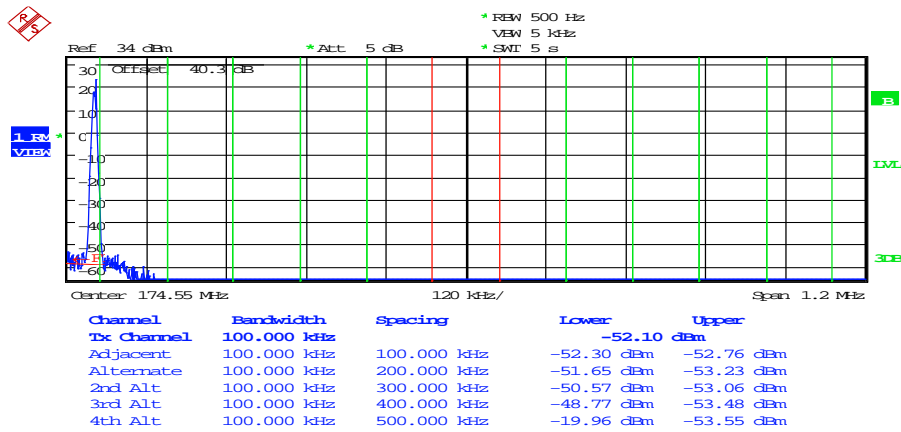

CQPSK Signal – Higher Bandedge

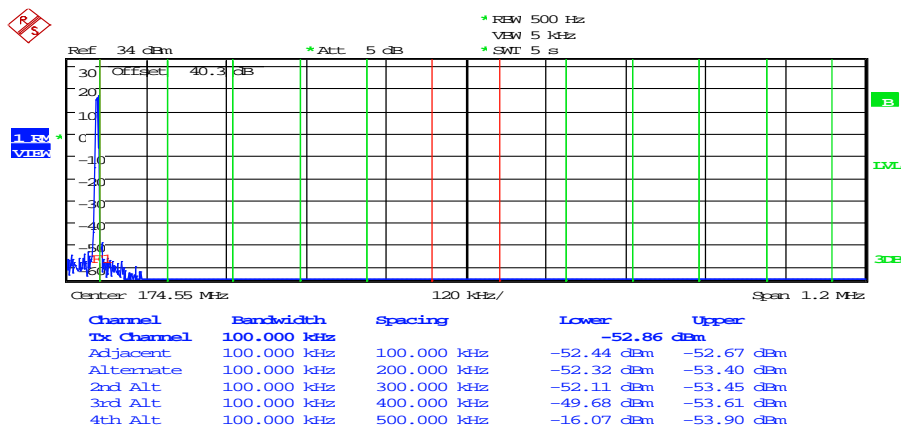

B5 Spurious Emissions at Antenna Terminals Greater than 1MHz

Test Details:	
Measurement standard	Part 2.1053, 90.219(e)(3)
EUT sample number	S01
Modification state	0
SE in test environment	None
SE isolated from EUT	None
EUT set up	Refer to Appendix C

Bottom Channel

Frequency Range (MHz)	Freq. of Emission (MHz)	Measured Level (dBm)	Attenuator & Cable Losses (dB)	Spurious Emission Level (dBm)	Limit dBm
9kHz - 2GHz	No Significant Emissions Within 10 dB of the Limit				-13

Middle Channel

Frequency Range (MHz)	Freq. of Emission (MHz)	Measured Level (dBm)	Attenuator & Cable Losses (dB)	Spurious Emission Level (dBm)	Limit dBm
9kHz - 2GHz	No Significant Emissions Within 10 dB of the Limit				-13

Top channel

Frequency Range (MHz)	Freq. of Emission (MHz)	Measured Level (dBm)	Attenuator & Cable Losses (dB)	Spurious Emission Level (dBm)	Limit dBm
9kHz - 2GHz	No Significant Emissions Within 10 dB of the Limit				-13

LIMIT =-13 dBm

Result

The EUT was found to comply with the limits

150.00625MHz Spurious Emissions at Antenna Terminals Greater than 1MHz

9-150kHz

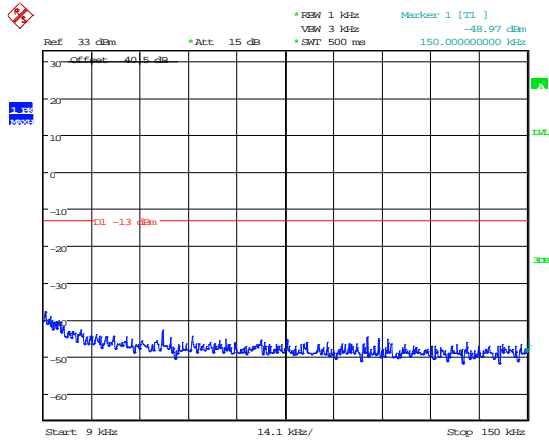

Date: 5.MAY.2015 11:54:01

150kHz – 30MHz

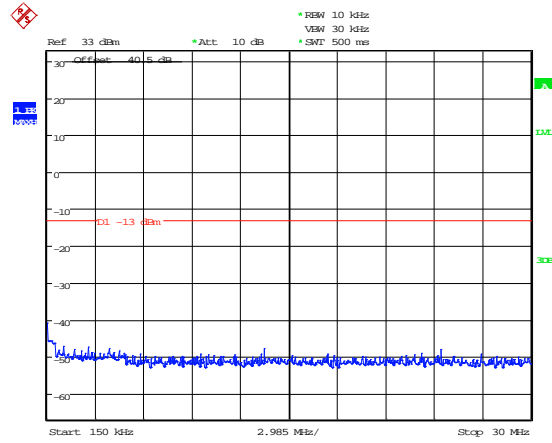

Date: 5.MAY.2015 11:54:43

30MHz – 1GHz

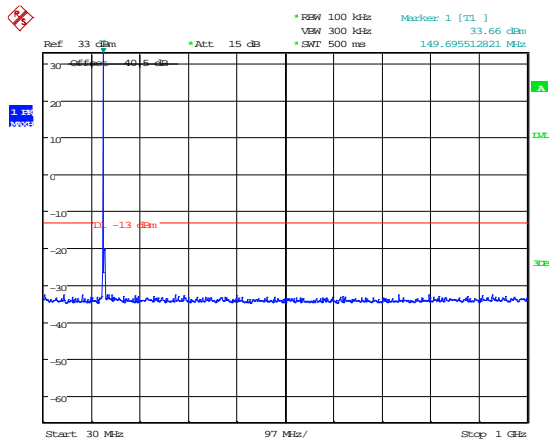

Date: 5.MAY.2015 11:53:30

1GHz – 2GHz

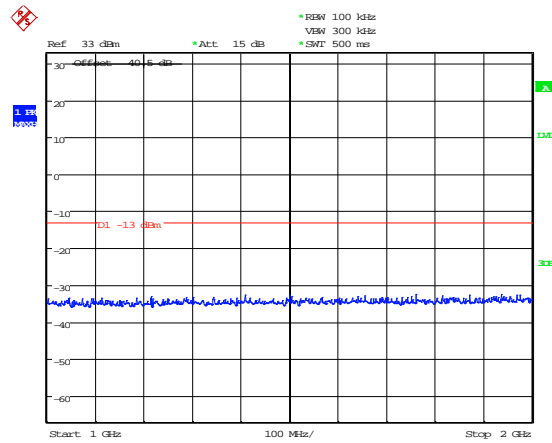

Date: 5.MAY.2015 11:55:42

161.7MHz Spurious Emissions at Antenna Terminals Greater than 1MHz

9-150kHz

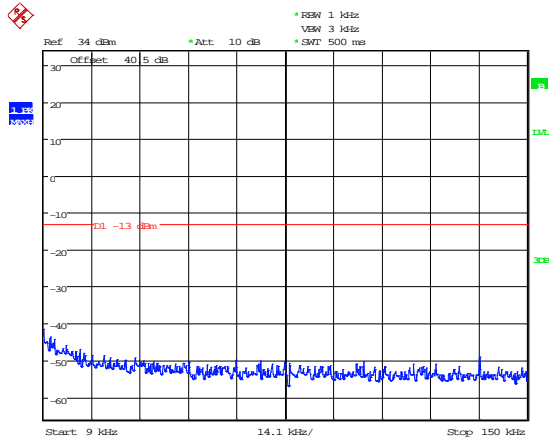

Date: 12.MAY.2015 16:53:12

150kHz – 30MHz

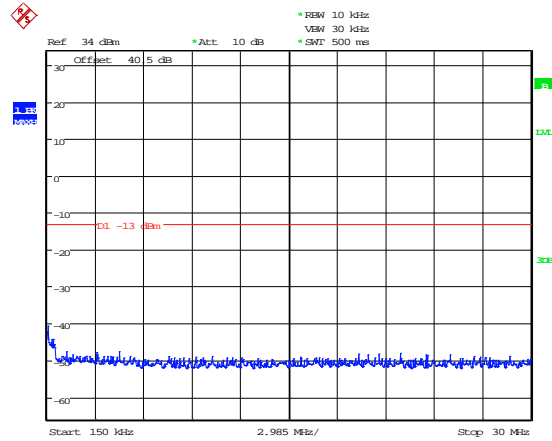

Date: 12.MAY.2015 16:53:40

30MHz – 1GHz

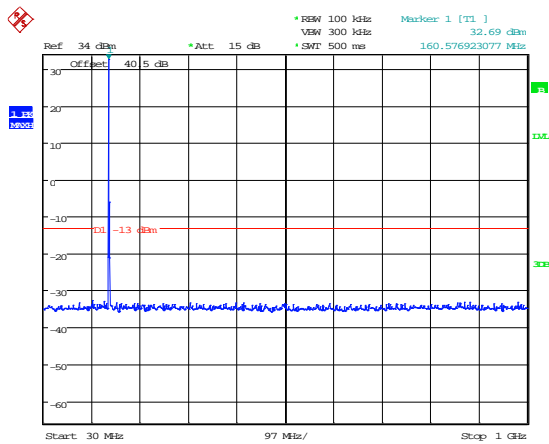

Date: 12.MAY.2015 16:51:57

1GHz – 2GHz

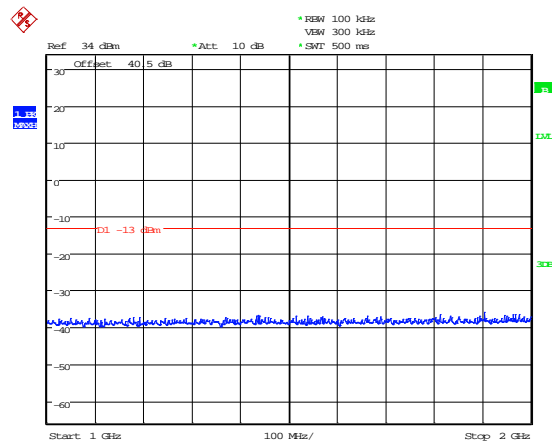

Date: 12.MAY.2015 16:52:41

173.39375MHz Spurious Emissions at Antenna Terminals Greater than 1MHz

9-150kHz

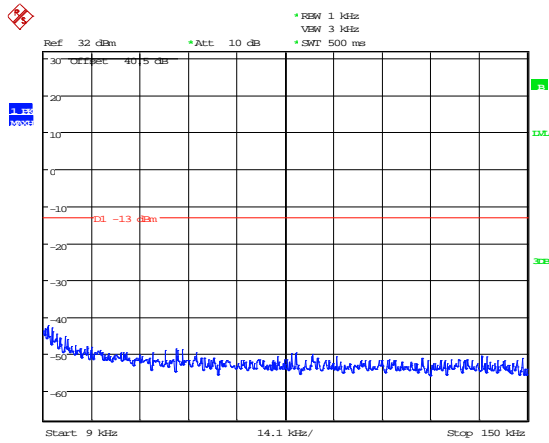

Date: 14.MAY.2015 17:50:55

150kHz – 30MHz

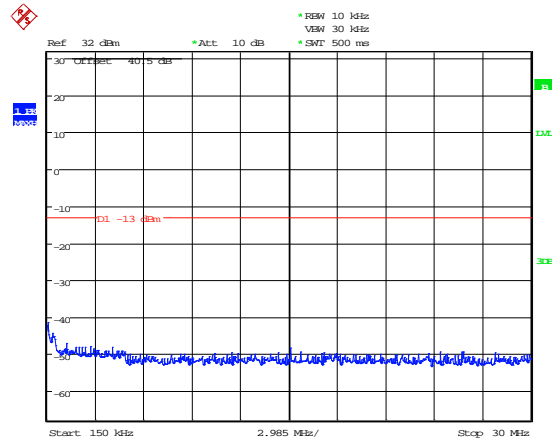

Date: 14.MAY.2015 17:51:29

30MHz – 1GHz

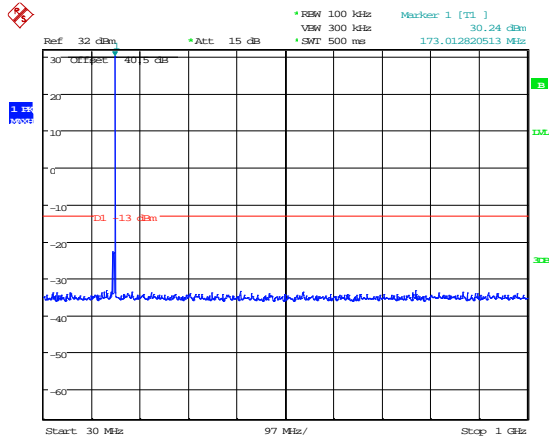

Date: 14.MAY.2015 17:50:01

1GHz – 2GHz

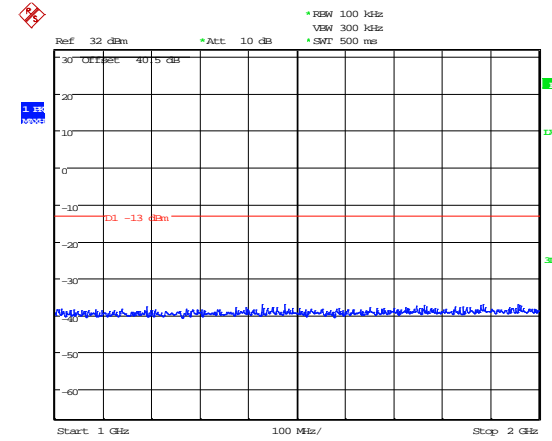

Date: 14.MAY.2015 17:50:27

B6 Noise at Antenna Terminals

Test Details:	
Measurement standard	90.219(e)(2)
EUT sample number	S01
Modification state	0
SE in test environment	None
SE isolated from EUT	None
EUT set up	Refer to Appendix C

Compliance with these levels will be deemed satisfaction of the good engineering practice requirement. In a 10 kHz measurement bandwidth:

- (1) the ERP of noise within the signal booster passband should not exceed -43dBm ;
- and
- (2) the ERP of noise on spectrum more than 1 MHz outside of the signal booster passband should not exceed -70 dBm .
 - (3) The noise figure of a signal booster must not exceed 9 dB in either direction

See appendix D for manufactures declaration on good engineering practice.

Test equipment used:-

TRaC No	Equipment Type	Equipment Description	Manufacturer	Last Cal Calibration	Calibration Period	Due For Calibration
UH405	FSU26	Spectrum Analyser	R&S	11/05/2015	12	11/05/2016
UH271	1.5m N type	Cable	TRaC	Cal in use		

The amplifier was connected to directly to the analyser via a cable. The analyser was tune to the selected open operating band of the analyser and the noise results recorded.

IN BAND AMPLIFIER NOISE – Lower 5 MHz Band Close view

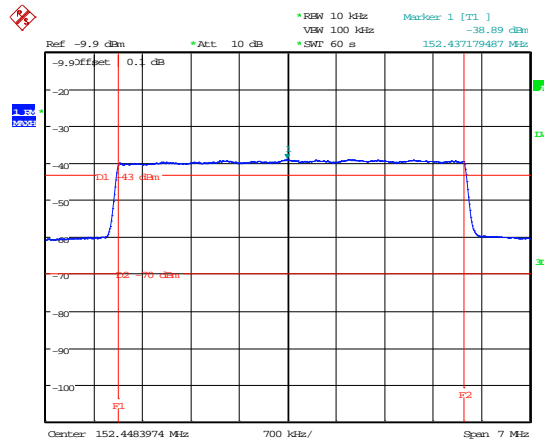

Date: 5.MAY.2015 16:12:15

IN BAND AMPLIFIER NOISE – Lower 5 MHz Band Wide view

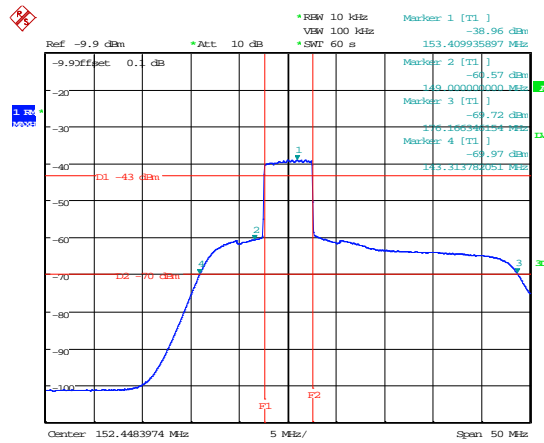

Date: 5.MAY.2015 16:09:12

IN BAND AMPLIFIER NOISE – Mid 5 MHz Band Close view

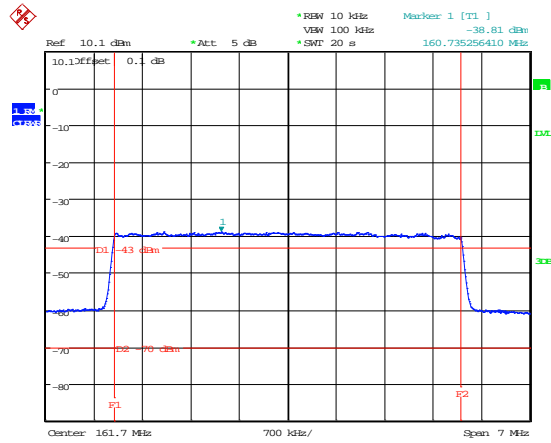

Date: 13.MAY.2015 10:28:28

IN BAND AMPLIFIER NOISE – Upper 5 MHz Band Wide view

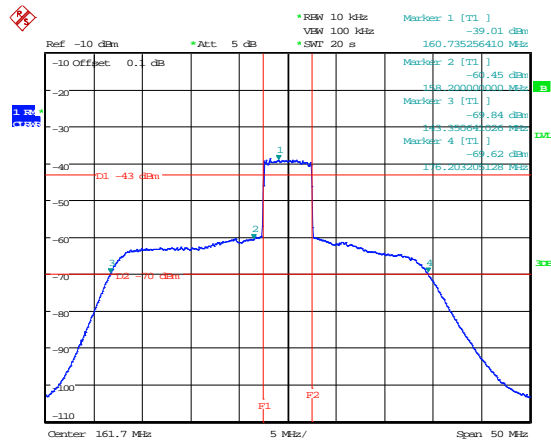

Date: 13.MAY.2015 10:30:58

IN BAND AMPLIFIER NOISE – Top 5 MHz Band Close view

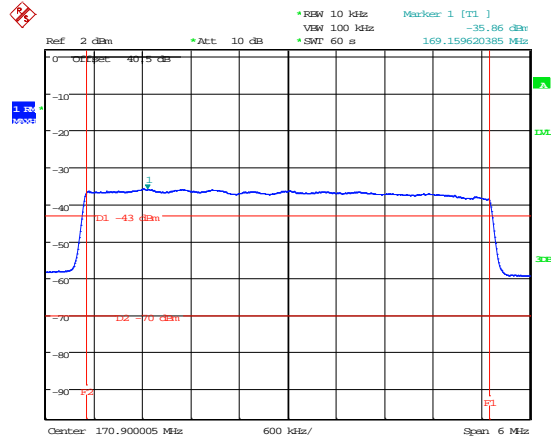

Date: 15.MAY.2015 14:11:01

IN BAND AMPLIFIER NOISE – Top 5 MHz Band Wide view

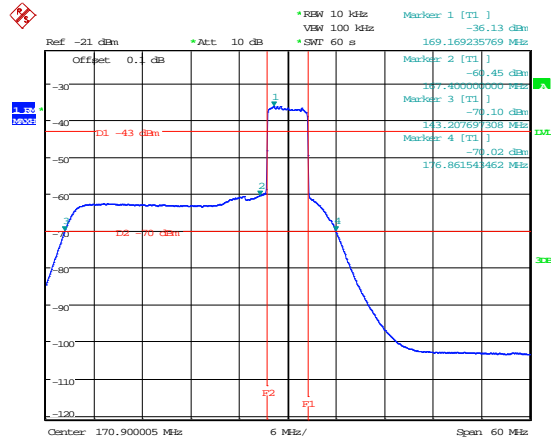

Date: 15.MAY.2015 14:15:58

B7 Radiated Electric Field Emissions

Preliminary scans were performed using a peak detector with the RBW = 100kHz. The radiated electric field emission test applies to all spurious and harmonic emissions. The EUT was set to transmit as required.

The following test site was used for final measurements as specified by the standard tested to:

3m open area test site : 3m alternative test site :

Test Details:	
Measurement standard	Title 47 of the CFR: Part 90.219(e)(3)
Frequency range	30 MHz – 2 GHz
EUT sample number	S01
Modification state	0
SE in test environment	None
SE isolated from EUT	None
EUT set up	Refer to Appendix C

Bottom Frequency

FREQUENCY RANGE	FREQ. (MHz)	ERP/EIRP (dBm)	LIMIT (dBm)
30MHz - 2GHz	No Significant Emissions Within 10 dB of the Limit		-13

Middle Frequency

FREQUENCY RANGE	FREQ. (MHz)	ERP/EIRP (dBm)	LIMIT (dBm)
30MHz - 2GHz	No Significant Emissions Within 10 dB of the Limit		-13

Top Frequency

FREQUENCY RANGE	FREQ. (MHz)	ERP/EIRP (dBm)	LIMIT (dBm)
30MHz - 2GHz	No Significant Emissions Within 10 dB of the Limit		-13

Result

The EUT was found to comply with the limits

Notes:

1. Emissions Checked up to 10 times Fc.
2. The unit was mounted on a turntable and rotated through 360° to find the worst case emission.
3. For Frequencies below 1 GHz, RBW = 120 kHz, testing was performed with CISPR16 compliant test receiver with Pk detector. Above 1 GHz tests were performed using a spectrum analyser using the following settings:

Peak Detector RBW = 1MHz; VBW = ≥RBW

4. Limit is determined as follows.

LIMIT = -13 dBm

The upper and lower frequency of the measurement range was decided according to 47 CFR Part 2.1057.

- (a) Where results have been measured at one distance, and a signal level displayed at another, the results have been extrapolated using the following formula:

$$\text{Extrapolation (dB)} = 20 \log_{10} \left(\frac{\text{measurement distance}}{\text{specification distance}} \right)$$

- (b) The levels may have been rounded for display purposes.
- (c) The following table summarises the effect of the EUT operating mode, internal configuration and arrangement of cables / samples on the measured emission levels:
- (d) Any spurious emission found to be within 20dB of the limit on the pre scans, the final measurement was performed using the antenna substitution method. This value was used against the limit.

	See (i)	See (ii)	See (iii)	See (iv)
Effect of EUT operating mode on emission levels	✓			
Effect of EUT internal configuration on emission levels	✓			
Effect of Position of EUT cables & samples on emission levels	✓			
(i) Parameter defined by standard and / or single possible, refer to Appendix D (ii) Parameter defined by client and / or single possible, refer to Appendix D (iii) Parameter had a negligible effect on emission levels, refer to Appendix D (iv) Worst case determined by initial measurement, refer to Appendix D				

150.00625MHz Radiated Electric Field Emissions

30MHz – 1GHz

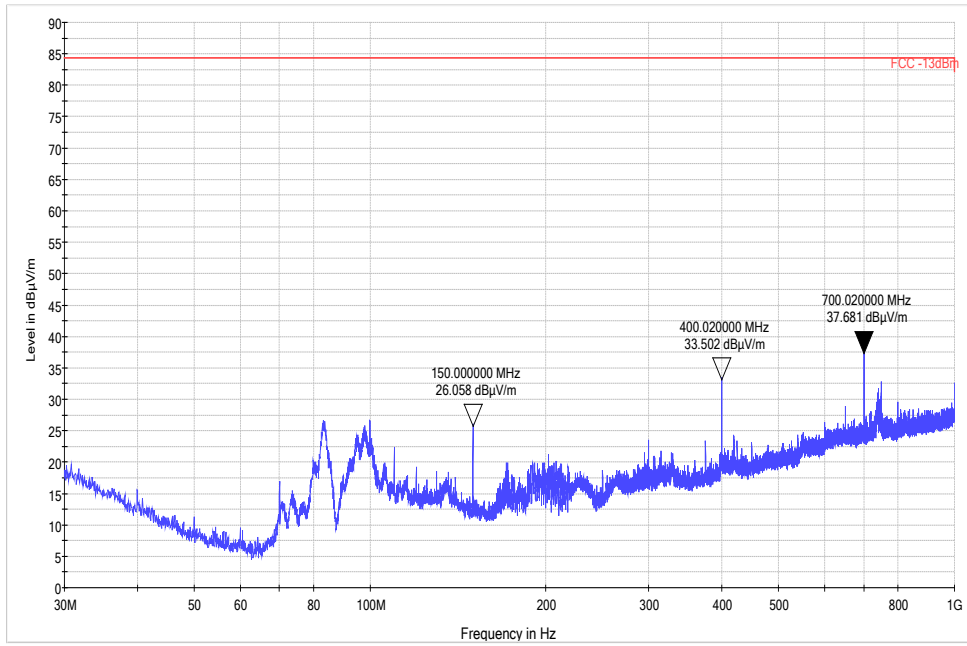

1GHz – 2GHz

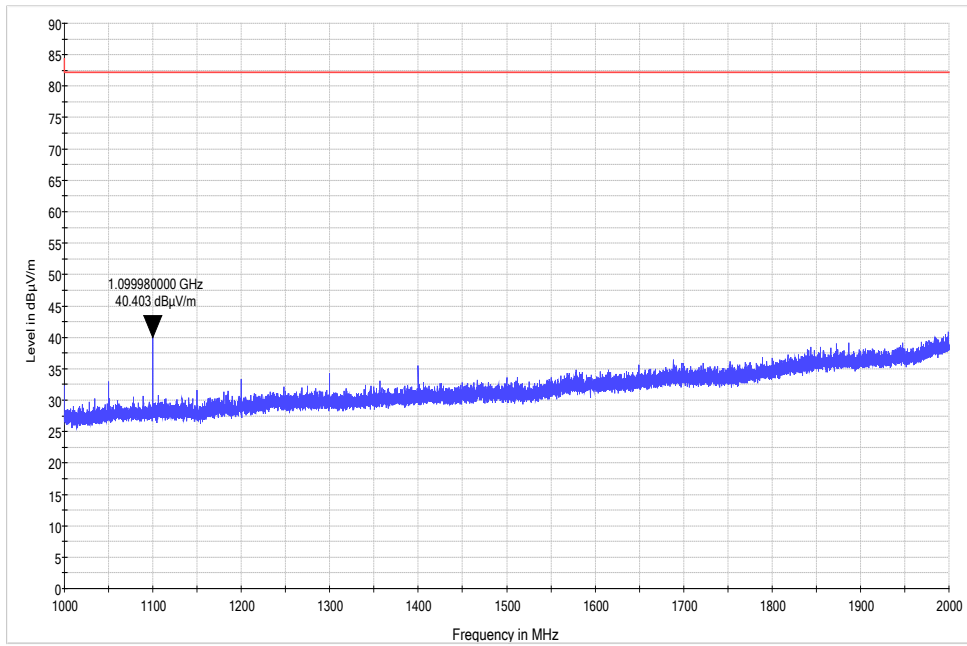

161.7MHz Radiated Electric Field Emissions

30MHz – 1GHz

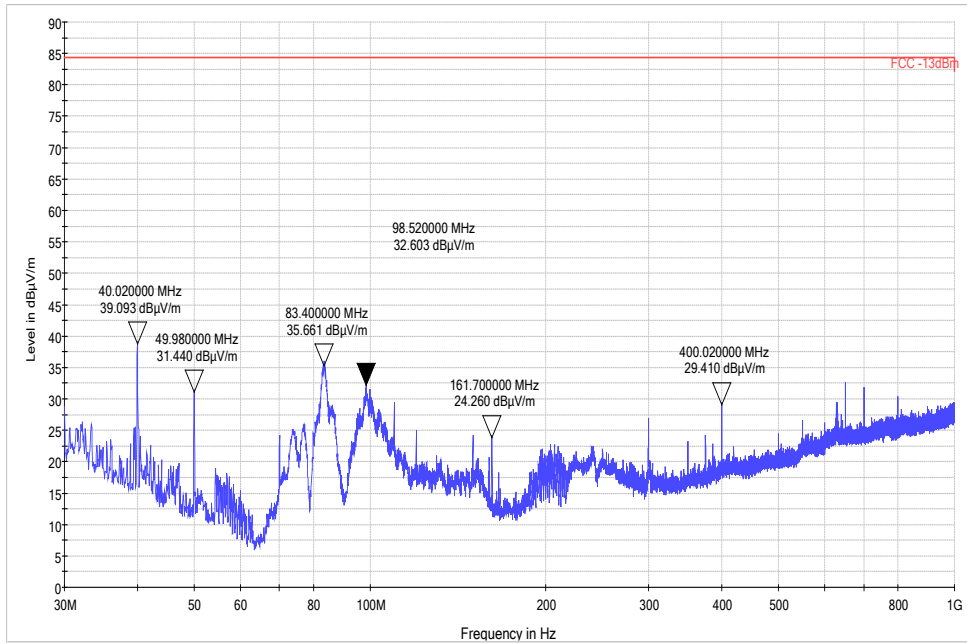

1GHz – 2GHz

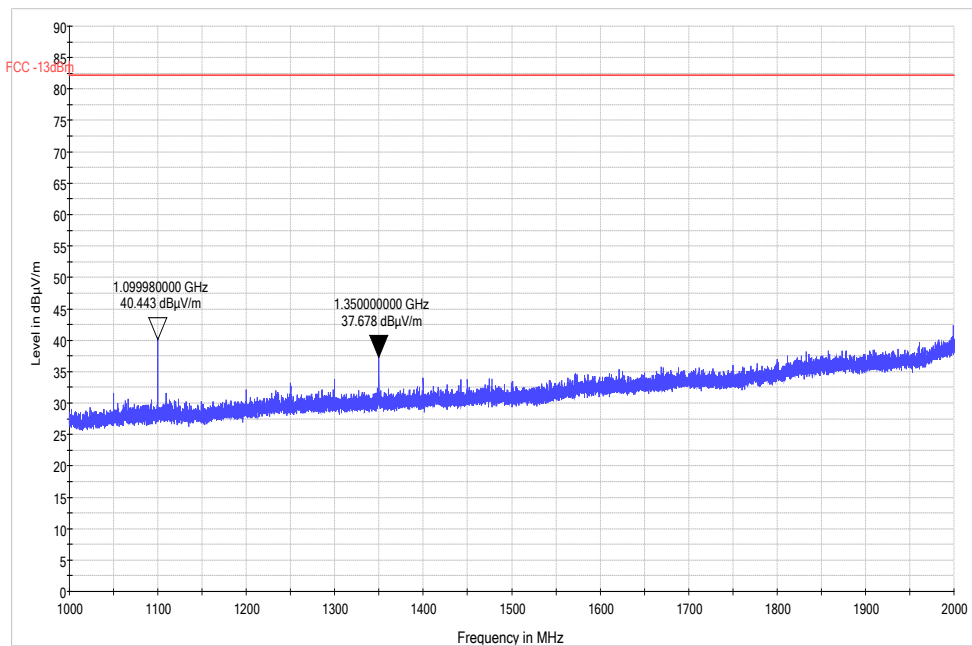

173.39375MHz Radiated Electric Field Emissions

30MHz – 1GHz

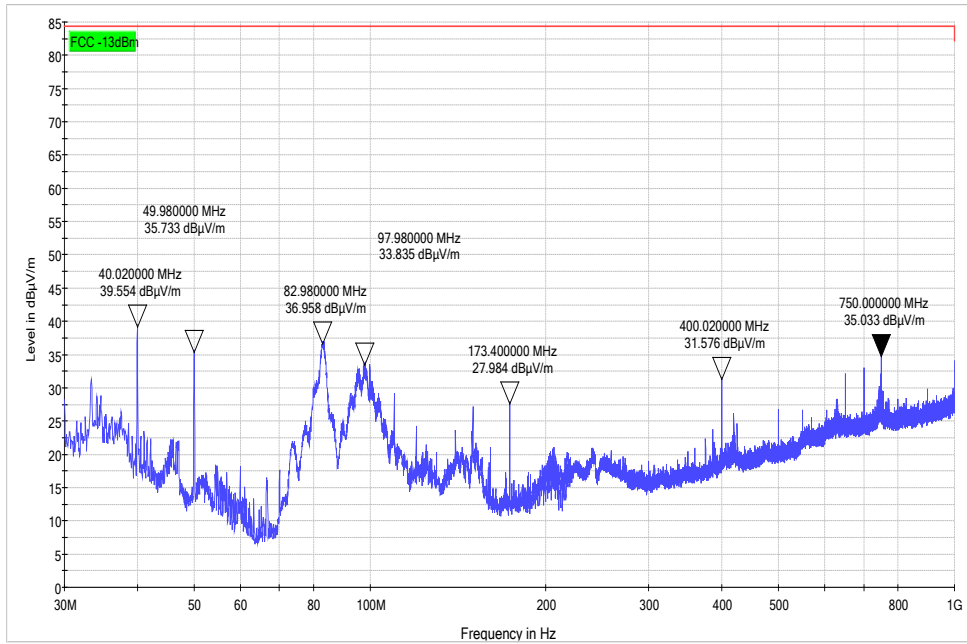

1GHz – 2GHz

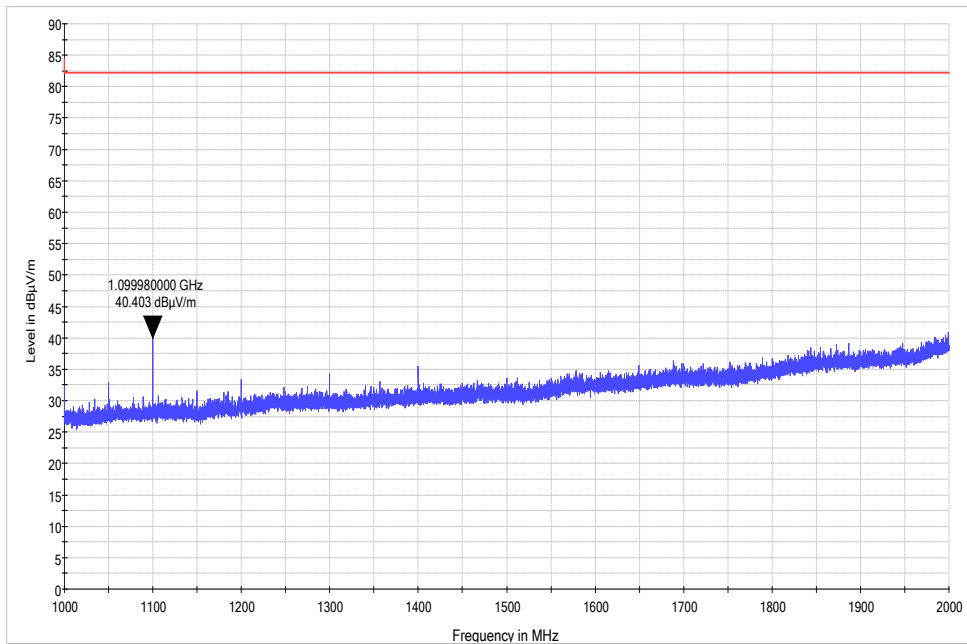

B8 Passband Gain & Bandwidth

Test Details:	
Measurement standard	D.3 Policies + Procedures (k) of KDB 935210 D02 Signal Boosters Certification v02
EUT sample number	30 MHz – 2 GHz
Modification state	S01
SE in test environment	0
SE isolated from EUT	None
EUT set up	Refer to Appendix C

Frequency MHz	F _l MHz	F _h MHz	20 dB Bandwidth
152.5MHz	149.870000	155.135000	5.265MHz
161.7MHz	159.070000	164.330000	5.260MHz
170.9MHz	168.255000	173.530000	5.275MHz

1. See below for plots showing passband gain & bandwidth

With the aid of a CW Swept signal generator and spectrum analyser, the bandwidth and frequency response of the open channel (i.e. at the point where the gain has fallen by 20 dB) is measured. This measurement shows the gain-versus-frequency response of the open channel from the midband frequency f_0 of the channel up to at least $f_0 + 250\%$ of the 20 dB bandwidth.

Lower 5 MHz band – 152.5MHz

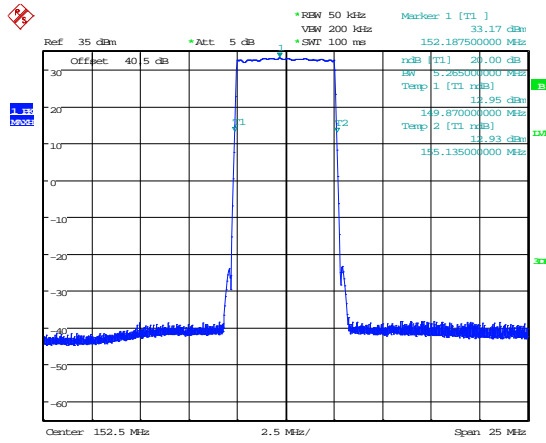

Date: 11.MAY.2015 14:02:36

Mid 5 MHz band – 161.7MHz

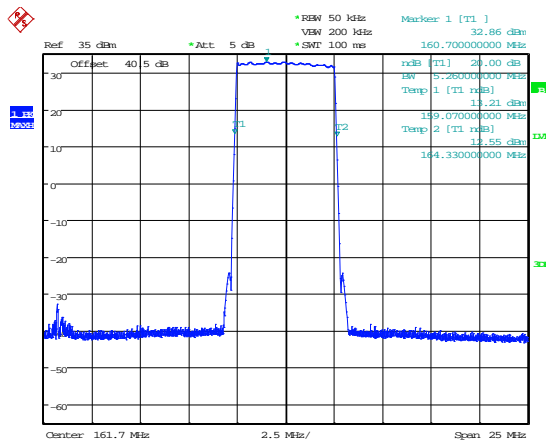

Date: 13.MAY.2015 14:52:13

Upper 5 MHz band – 170.9MHz

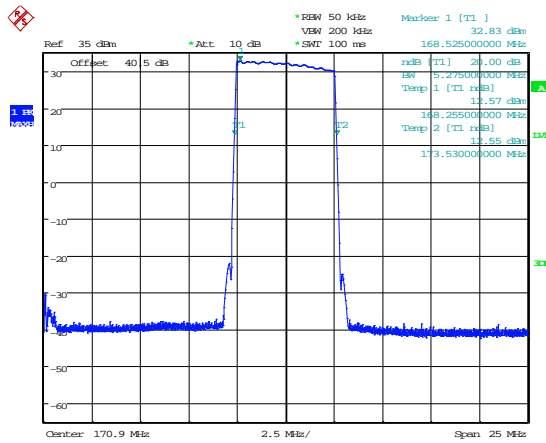

Date: 18.MAY.2015 12:24:29

Appendix C:**Additional Test and Sample Details**

This appendix contains details of:

1. The samples submitted for testing.
2. Details of EUT operating mode(s)
3. Details of EUT configuration(s) (see below).
4. EUT arrangement (see below).

Throughout testing, the following numbering system is used to show the sample and it's modification state:

Sample No: Sxx Mod w

where:

xx	= sample number	eg. S01
w	= modification number	eg. Mod 2

The following terminology is used throughout the test report:

Support Equipment (SE) is any additional equipment required to exercise the EUT in the applicable operating mode. Where relevant SE is divided into two categories:

SE in test environment: The SE is positioned in the test environment and is not isolated from the EUT (e.g. on the table top during REFE testing).

SE isolated from the EUT: The SE is isolated via filtering from the EUT. (e.g. equipment placed externally to the ALSR during REFE testing).

EUT configuration refers to the internal set-up of the EUT. It may include for example:

- Positioning of cards in a chassis.
- Setting of any internal switches.
- Circuit board jumper settings.
- Alternative internal power supplies.

Where no change in EUT configuration is **possible**, the configuration is described as "single possible configuration".

EUT arrangement refers to the termination of EUT ports / connection of support equipment, and where relevant, the relative positioning of samples (EUT and SE) in the test environment.

For further details of the test procedures and general test set ups used during testing please refer to the related document "EMC Test Methods - An Overview", which can be supplied by TRaC Global upon request.

C1) Test samples

The following samples of the apparatus were submitted by the client for testing:

Sample No.	Description	Identification
S01	BSF3302	27754 G

The following samples of apparatus were submitted by the client as host, support or drive equipment (auxiliary equipment):

Sample No.	Description	Identification
S02	OMU	E4XT

The following samples of apparatus were supplied by TRaC Global as support or drive equipment (auxiliary equipment):

Identification	Description
None	

C2) EUT Operating Mode During Testing.

During testing, the EUT was exercised as described in the following tables:

Test	Description of Operating Mode
All tests detailed in this report	Receiving a signal to ensure EUT is operating a maximum gain and maximum output power.

C3) EUT Configuration Information.

The EUT was submitted for testing in one single possible configuration.

C4) List of EUT Ports

The tables below describe the termination of EUT ports:

Sample : S01
Tests : Conducted

Port	Description of Cable Attached	Cable length	Equipment Connected
Uplink DAS	Coaxial	>1m	Measurement System or 50Ω Load
Downlink DAS	Coaxial	>1m	Measurement System or 50Ω Load
Fibre	Fibre	>1m	OMU

Sample : S01
Tests : Radiated Emissions

Port	Description of Cable Attached	Cable length	Equipment Connected
Uplink DAS	Coaxial	>1m	Measurement System or 50Ω Load
Downlink DAS	Coaxial	>1m	Measurement System or 50Ω Load
Fibre	Fibre	>1m	OMU

* Only connected during setup.

C5 Details of Equipment Used

TRaC No	Equipment Type	Equipment Description	Manufacturer	Last Cal Calibration	Calibration Period	Due For Calibration
L138	3115	1-18GHz Horn	EMCO	17/10/2013	24	17/10/2015
L139	3115	1-18GHz Horn	EMCO	20/09/2013	24	20/09/2015
UH191	CBL611/A	Bilog	Chase	26/02/2015	24	26/02/2017
UH281	FSU46	Spectrum Analyser	R&S	24/04/2015	12	24/04/2016
UH387	ATS	Chamber 1	Rainford EMC	06/09/2014	12	06/09/2015
UH388	ATS	Chamber 2	Rainford EMC	05/09/2014	24	05/09/2016
UH405	FSU26	Spectrum Analyser	R&S	11/05/2015	12	11/05/2016
L176	2042	Signal Generator	Marconi	17/12/2014	12	17/12/2015
L254	2042	Signal Generator	Marconi	08/01/2014	12	08/01/2015
REF916	SMBV100A	Signal Generator	R&S	17/02/2015	12	17/02/2016
L290	CBL611/A	Bilog	Chase	02/12/2014	24	02/12/2016
L352	ESVS10	Receiver	R&S	26/03/2015	12	26/03/2016
L572	8449B	Pre Amp	Agilent	10/02/2015	12	10/02/2016
REF909	FSU26	Spectrum Analyser	R&S	13/02/2015	12	13/02/2016
REF940	ATS	Radio Chamber - PP	Rainford EMC	08/09/2014	24	08/09/2016
UH253	1m N type	Cable	TRaC	Cal in use		
UH254	1m N type	Cable	TRaC	Cal in use		
UH269	1m N type	Cable	TRaC	Cal in use		
UH271	1.5m N type	Cable	TRaC	Cal in use		
UH272	1.5m N type	Cable	TRaC	Cal in use		
UH273	2m N type	Cable	TRaC	Cal in use		
UH274	2m N type	Cable	TRaC	Cal in use		
TRLUH225	100W 20dB	Attenuator	Spinner	Cal in use		
-	100W 20dB	Attenuator	N/A	Cal in use		

Appendix D:

Additional Information

1.1.1 Antenna Installation

Installation of an antenna must comply with the FCC RF exposure requirements. The antenna used for this transmitter must be mounted on permanent structures.

The FCC regulations mandate that the ERP of type B signal boosters should not exceed 5W, this is equivalent to 8.2W EIRP.

Therefore the max antenna gain allowed for this type of signal booster should be limited to the values given by equation 1 (below) for the service antenna.

Equation (1) - Max SERVICE antenna gain

Max SERVICE antenna gain (dBi) = $39.1 - (37\text{dBm} - \# \text{ of antennas in dB} - \text{cable losses in dB})$.

For example:

No. of Antennas	Cable Losses	Max Allowed Antenna Gain
4	3	$39.1 - (37-6-3) = 11.1\text{dBi}$
1	3	$39.1 - (37-0-3) = 5.1\text{dBi}$
10	3	$39.1 - (37-10-3) = 15.1\text{dBi}$

Compliance with FCC deployment rule regarding the radiation of noise

Good engineering practice must be used in regard to the signal booster's noise radiation. Thus, the gain of the signal booster should be set so that the ERP of the output noise from the signal booster should not exceed the level of -43 dBm in 10 kHz measurement bandwidth.

In the event that the noise level measured exceeds the aforementioned value, the signal booster gain should be decreased accordingly.

In general, the ERP of noise on a spectrum more than 1 MHz outside of the pass band should not exceed -70 dBm in a 10 kHz measurement bandwidth.

The 3302 61-200001 Series Repeater has a noise level of -60 dBm in 10 kHz measurement at 1 MHz spectrum outside the passband of the signal booster and an in-band noise level at around -36 dBm in a 10 kHz bandwidth. Therefore, the noise at the antenna input port should be calculated based on equation (3).

Equation (2) - Input Noise to service antenna

Input Noise to service antenna:

$-36\text{ dBm} - \text{Antenna splitter losses in dB} - \text{cable loss in dB}$

Example: In band Noise

Signal booster connected to 10 service antennas with a 100m long ½ inch cable.
Losses of such a cable with the connectors = ~ 12dB

Assuming 10 service antennas: antenna splitter losses = 11 dB

Based on equation (2) Input antenna noise (to the antenna) = $-36-12-11=-59$ dBm ERP

The in-band input noise to the antenna should be $-36-12-11=-59$ dbm ERP

Example: Out of band noise

Signal booster connected to 10 service antennas with a 100m long ½ inch cable.
Losses of such a cable with the connectors = ~ 12dB

Assuming 10 service antennas: antenna splitter losses = 11 dB

Based on equation (2) Input antenna noise (to the antenna) = $-60-11-15=-83$ dBm ERP

The Out of-band input noise to the antenna should be $-60-12-11=-83$ dbm ERP

NOTE: In this example there is no need to add an external band pass filter to attenuate the out of band noise. If fewer antennas are deployed then additional filtering may be required

Conclusion:

Good engineering practice requires that in general when the out of band noise measured at the service antenna input is more than -70 dBm per 10 kHz measurement bandwidth, an external band pass filter should be added to attenuate the out of band noise level.

All Axell Wireless repeaters include high selectivity duplexers and filters to attenuate the out of band noise. Should additional filtering be required, we have a comprehensive range of interference filters which can be supplied upon request.

Compliance with FCC Part 90.219 (d)(6)(i)

The deployment rules require that the ERP of intermodulation products should in general not exceed -30dbm. This is not a formidable task since in the vast majority of the passive DAS installations, the signal loss in the DAS due to splitting to multiple antenna and cable losses is significant.

As well as the above the BSF3302 is more likely to be used in a multicarrier environment (more than 2 carriers), which in turn will reduce the intermodulation products produced by the device. The following statement is already in the user manual to highlight the requirement to the installer for the the instances where the above does not reduce the ERP of the intermodulation products to -30dBm.

'The installation procedure must result in the signal booster complying with FCC requirements 90.219(d). In order to meet FCC requirements 90.219(d), it may be necessary for the installer to reduce the UL and/or DL output power for certain installations.'

Appendix E: Photographs and Figures

The following photographs were taken of the test samples:

1. Radiated electric field emissions arrangement: front view.
2. Radiated electric field emissions arrangement: close up.

Photograph 1



Photograph 2



