

Report on the Radio Testing

For

Axell Wireless Limited

on

UHF Fibre Fed Band Selective Booster

Report no. TRA-029498-47-01B

20th July 2017

RF926

Report Number: TRA-029498-47-01B
Issue: A

REPORT ON THE RADIO TESTING OF A
Axell Wireless Limited
UHF Fibre Fed Band Selective Booster
WITH RESPECT TO SPECIFICATION
FCC 47CFR 90

TEST DATE: 19th October-10th November 2016

Written by: S Hodgkinson

S Hodgkinson
Radio Test Engineer

Approved by:

J Charters
Department Manager - Radio

Date: 20th July 2017

Disclaimers:

- [1] THIS DOCUMENT MAY BE REPRODUCED ONLY IN ITS ENTIRETY AND WITHOUT CHANGE
[2] THE RESULTS CONTAINED IN THIS DOCUMENT RELATE ONLY TO THE ITEM(S) TESTED

1 Revision Record

<i>Issue Number</i>	<i>Issue Date</i>	<i>Revision History</i>
A	17 th November 2016	Original
B	13 th April 2017	TBC requested modification

2 Summary

TEST REPORT NUMBER: TRA-029498-47-01B

WORKS ORDER NUMBER: TRA-029498-00

PURPOSE OF TEST: USA: Testing of radio frequency equipment per the relevant authorization procedure of chapter 47 of CFR (code of federal regulations) Part 2, subpart J.
Canada: Testing of radio apparatus for TAC (technical acceptance certificate) per subsections 4(2) of the Radio communication Act and 21(1) of the Radio communication Regulations

TEST SPECIFICATION: 47CFR90

EQUIPMENT UNDER TEST (EUT): UHF Fibre Fed Band Selective Booster

FCC IDENTIFIER: NEO61-103SERIES

EUT SERIAL NUMBER: 28197G

MANUFACTURER/AGENT: Axell Wireless Limited

ADDRESS: Aerial House
Asheridge Road
Chesham
Bucks
HP5 2QD
United Kingdom

CLIENT CONTACT: Brian Barton
☎ 01494 777 014
✉ Brian.Barton@axellwireless.com

ORDER NUMBER: 111408

TEST DATE: 19th October-10th November 2016

TESTED BY: S Hodgkinson
Element

2.1 Test Summary

Test Method and Description	Requirement Clause	Applicable to this equipment	Result / Note
	47CFR90		
RF power output	90.219(e)(1)	☒	Pass
Modulation characteristics			
Noise figure	90.219(e)(2)	☒	Pass
Retransmitted masks	90.219(e)(4)(ii); 90.219(e)(4)(iii)	☒	Pass
Occupied bandwidth			
Passband gain and bandwidth	-	☒	Pass
Spurious emissions at antenna terminals	90.219(e)(3)	☒	Pass
Intermodulation products	-	☒	Pass
Field strength of spurious radiation	90.219(e)(3)	☒	Pass
Frequency stability	90.213	☒	Not applicable

Notes:

The results contained in this report relate only to the items tested, in the condition at time of test, and were obtained in the period between the date of initial receipt of samples and the date of issue of the report.

The apparatus was set-up and exercised using the configurations, modes of operation and arrangements defined in this report only. Any modifications made are identified in Section 8 of this report.

Particular operating modes, apparatus monitoring methods and performance criteria required by the standards tested to have been performed except where identified in Section 5.2 of this test report (Deviations from Test Standards).

3 Contents

1	Revision Record	3
2	Summary	4
2.1	Test Summary	5
3	Contents	6
4	Introduction	8
5	Test Specifications	9
5.1	Normative References	9
5.2	Deviations from Test Standards	9
6	Glossary of Terms	10
7	Equipment Under Test	11
7.1	EUT Identification	11
7.2	System Equipment	11
7.3	EUT Mode of Operation	11
7.3.1	Transmissions downlink	11
7.4	EUT Radio Frequency Parameters	11
7.4.1	General	11
7.5	EUT Description	11
8	Modifications	12
9	EUT Test Setup	13
9.1	Block Diagram	13
9.2	General Set-up Photograph	13
10	General Technical Parameters	14
10.1	Normal Conditions	14
10.2	Varying Test Conditions	14
10.3	AGC threshold	14
11	RF power output (mean output power)	15
11.1	Definition	15
11.2	Test Parameters	15
11.3	Test Limits	15
11.3.1	47CFR90	15
11.4	Test Method	15
11.5	Test Equipment	16
11.6	Test Results	17
12	Noise figure	18
12.1	Definition	18
12.2	Test Parameters	18
12.3	Test Limits	18
12.4	Test Equipment	19
12.5	Test Results	19
12.6	Client Supplied Details of Antenna Installation	22
13	Retransmitted masks	23
13.1	Definition	23
13.2	Test Parameters	23
13.3	Test Limits	23
13.3.1	FCC 47CFR90	23
13.4	Test Method	26
13.5	Test Equipment	26
13.6	Test Results	26
14	Passband gain and bandwidth	42
14.1	Definition	42
14.2	Test Parameters	42
14.3	Test Limits	42
14.3.1	FCC 47CFR90	42
14.4	Test Method	42
14.5	Test Equipment	43
14.6	Test Results	44
15	Spurious emissions at antenna terminals	47
15.1	Definition	47
15.2	Test Parameters	47
15.3	Test Limits	47
15.3.1	47CFR90	47
15.4	Test Method	47
15.5	Test Equipment	48
15.6	Test Results	48
15.6.1	Out-of-band	48
16	Intermodulation products	55
16.1	Definition	55

16.2	Test Parameters	55
16.3	Test Limits	55
16.4	Test Method.....	55
16.5	Test Equipment	56
16.6	Test Results.....	56
16.1	Client Supplied Details of Antenna Installation	67
17	Field strength of spurious radiation.....	69
17.1	Definitions	69
17.2	Test Parameters	69
17.3	Test Limits	69
17.4	Test Method.....	69
17.5	Test Equipment	71
17.6	Test Results.....	71
18	Frequency stability.....	75
18.1	Definition.....	75
18.2	Test Parameters	75
18.3	Test Limits	75
18.3.1	47CFR90	75
18.4	Test Method.....	75
19	Client Declaration	76
20	Measurement Uncertainty.....	77

4 Introduction

This report TRA-029498-47-01B presents the results of the Radio testing on a Axell Wireless Limited, UHF Fibre Fed Band Selective Booster to specification 47CFR90.219 Use of signal boosters.

The testing was carried out for Axell Wireless Limited by Element, at the address(es) detailed below.

<input type="checkbox"/>	Element Hull Unit E South Orbital Trading Park Hedon Road Hull HU9 1NJ UK	<input checked="" type="checkbox"/>	Element Skelmersdale Unit 1 Pendle Place Skelmersdale West Lancashire WN8 9PN UK
--------------------------	---	-------------------------------------	--

This report details the configuration of the equipment, the test methods used and any relevant modifications where appropriate.

FCC Site Listing:

The test laboratory is accredited for the above sites under the US-EU MRA, Designation number UK0009.

ISED Registration Number(s):

Element Skelmersdale	3930B-4
Element Hull	3483A

The test site requirements of ANSI C63.4-2014 are met up to 1GHz.

The test site SVSWR requirements of CISPR 16-1-4:2010 are met over the frequency range 1 GHz to 18 GHz.

5 Test Specifications

5.1 Normative References

- FCC 47 CFR Ch. I – Part 90 – Private Land Mobile Radio Services
- FCC KDB Publication 935210 D05 v01r01 Feb 12 , 2015 – Measurements guidance for industrial and non-consumer signal booster, repeater and amplifier devices.
- TIA-603-D-2010 – Land Mobile FM or PM - Communications Equipment - Measurement and Performance Standards
- ANSI C63.4-2014 – American National Standard for Methods of Measurement of Radio-Noise Emissions from Low-Voltage Electrical and Electronic Equipment in the Range of 9 kHz to 40 GHz.
- Industry Canada RSS-131, Issue 2, July 2003 – Zone Enhancers for the Land Mobile Service

5.2 Deviations from Test Standards

There were no deviations from the test standard.

6 Glossary of Terms

§	Denotes a section reference from the standard, not this document
AC	Alternating Current
AM	Amplitude Modulated
AWGN	Additive White Gaussian Noise
BW	Bandwidth
C	Celsius
CW	Continuous Wave
Class A	Class A signal booster is designed to retransmit signals on one or more specific channels where none of its passbands exceed 75kHz.
Class B	Class B signal booster is designed to retransmit any signals within a wide frequency band greater than 75kHz.
dB	Decibels
dBm	dB relative to 1 milliwatt
CDMA	Code Division Multiple Access – a modulation technique used in cellular networks
DC	Direct Current
EIRP	Equivalent Isotropically Radiated Power
emf	electromotive force
erp	Effective Radiated Power
EUT	Equipment Under Test
f	Frequency
FCC	Federal Communications Commission
GSM	Group Special Mobile – a cellular network standard
Hz	Hertz
IC	Industry Canada (now ISED)
IF	Intermediate Frequency
ISED	Innovation, Science and Economic Development Canada
ITU	International Telecommunication Union
KDB	Knowledge Data Base (of the FCC Office of Engineering and Technology).
LO	Local Oscillator
m	metre
max	Maximum
min	Minimum
N/A	Not Applicable
No.	Number
PCB	Printed Circuit Board
PDF	Portable Document Format
PLMR	Private Land Mobile Radio
RE	Radio Equipment
RF	Radio Frequency
RH	Relative Humidity
RMS	Root Mean Square
Rx	Receiver
s	Second
Tx	Transmitter
UKAS	United Kingdom Accreditation Service
V	Volt
W	Watt
Ω	Ohm

7 Equipment Under Test

7.1 EUT Identification

- Name: UHF Fibre Fed Band Selective Booster
- Serial Number: 28197G
- Model Number: 61-103001
- Software Revision: SW00360 REV 1
- Build Level / Revision Number: REV 1

7.2 System Equipment

Equipment listed below forms part of the overall test setup and is required for equipment functionality and/or monitoring during testing. The compliance levels achieved in this report relate only to the EUT and not items given in the following list.

Optical Master Unit (omu)

7.3 EUT Mode of Operation

7.3.1 Transmissions downlink

The mode of operation for Tx tests was as follows
The equipment was operating at maximum gain and output power

7.4 EUT Radio Frequency Parameters

7.4.1 General

Frequency of operation:	490-510MHz
Passband gain:	34.13dB
Supported channel bandwidth(s) & class:	Class B > 75 kHz
Nominal Supply Voltage:	125Vac – 110Vac

7.5 EUT Description

UHF Fibre Fed Band Selective Booster, the passband of the booster is 490MHz- 510MHz, only one 5MHz portion of the passband can be selected and operating at any one time.

8 Modifications

No modifications were performed during this assessment.

9 EUT Test Setup

9.1 Block Diagram

The following diagram shows basic EUT interconnections with cable type and cable lengths identified:

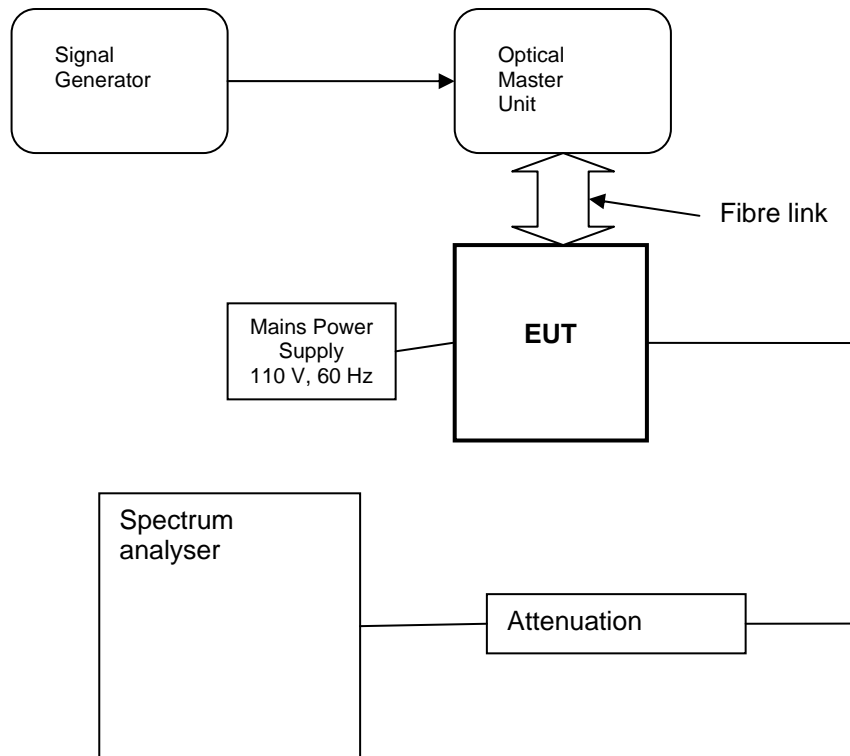

9.2 General Set-up Photograph



10 General Technical Parameters

10.1 Normal Conditions

The E U T was tested under the normal environmental conditions of the test laboratory, except where otherwise stated. The normal power source applied was approx. 110 V ac from the mains.

10.2 Varying Test Conditions

Variation of temperature is required to ensure stability of the declared fundamental frequency. During frequency error testing the following variations were made:

	Category	Variation
<input type="checkbox"/>	Standard	-20 to +50 C in 10 degree steps
<input type="checkbox"/>	Extended	

Variation of supply voltage is required to ensure stability of the declared output power and frequency. During carrier power and frequency error testing the following variations were made:

	Category	Nominal	Variation
<input checked="" type="checkbox"/>	Mains		85% and 115%
<input type="checkbox"/>	Battery	New battery	N/A

10.3 AGC threshold

Testing at and above the AGC threshold was required. The AGC threshold was therefore determined per KDB 935210 D05 v01r01 , clause 3.2.

Maximum level for AGC threshold

	Input Signal	AGC threshold
Downlink	CW	35.17dBm

	Input Signal level	AGC threshold
Downlink	1.34dBm	34.13dBm

11 RF power output (mean output power)

11.1 Definition

The average power supplied to the antenna transmission line by a transmitter during an interval of time sufficiently long compared with the lowest frequency encountered in the modulation taken under normal operating conditions.

11.2 Test Parameters

Test Location:	Element Skelmersdale
Test Chamber:	Radio lab
Test Standard and Clause:	KDB 935210 D05 v01r01, clause 4.5
EUT Operating Frequencies Tested:	490.00625MHz,500MHz, 509.99375MHz
Source Modulations:	CW,
Source Level:	1.67 dBm (maximum input rating)
Deviations From Standard:	None
Bandwidth:	RBW 100 kHz; VBW 3xRBW
Span:	1 MHz
Measurement Detector	Peak; Max-Hold.

Environmental Conditions (Normal Environment)

Temperature: 23°C	+15 °C to +35 °C (as declared)
Humidity: 34%RH	20%RH to 75%RH (as declared)
Supply: 110 V ac	

11.3 Test Limits

11.3.1 47CFR90

The output power capability of a signal booster must be designed for deployments providing a radiated power not exceeding 5 Watts ERP for each retransmitted channel.

11.4 Test Method

Single Channel:

With the EUT setup as per section 9 of this report and connected as per Figure i, the power of the EUT was calculated by taking into account any cable and attenuator calibration factors. It was confirmed that at the maximum input level there was no compression.

Gain was calculated by removing the EUT from the setup and measuring the signal generator to EUT level.

Figure i Test Setup

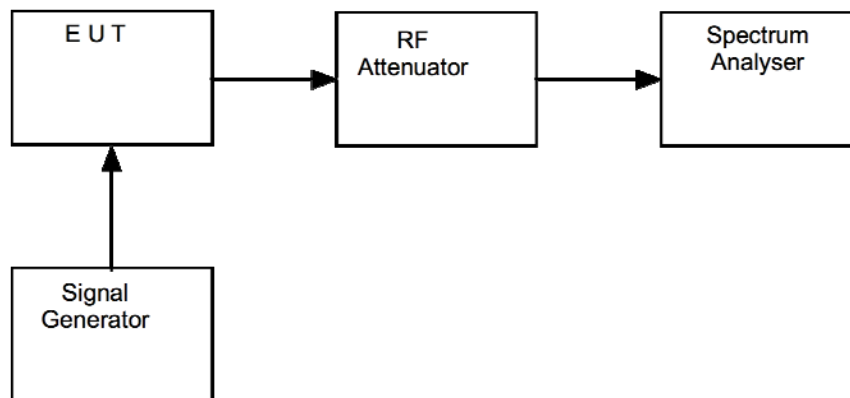

11.5 Test Equipment

<i>Equipment Description</i>	<i>Manufacturer</i>	<i>Equipment Type</i>	<i>Element No</i>	<i>Last Cal Calibration</i>	<i>Calibration Period</i>	<i>Due For Calibration</i>
Spectrum Analyser	R&S	FSU46	U281	07/06/2016	12	07/06/2017
Signal Generator	R&S	SMBV100A	REF916	21/03/2016	12	21/03/2017
Signal Generator	Marconi	2042	L176	04/01/2016	12	04/01/2017

11.6 Test Results

Single Channel @ AGC Threshold								
Channel Centre Frequency (MHz)	Modulation	Signal Generator Input Level (dBm)	Input Cable Loss (dB)	Level at Spectrum Analyser (dBm)	Output Cable & Attenuator Loss (dB)	Gain (dB)	Conducted Output Power (dBm)	Result
490.00625	CW	1.34	0.3	-6.03	41.0	33.93	34.97	PASS
500.0000	CW	1.34	0.3	-5.83	41.0	34.13	35.17	PASS
499.99375	CW	1.67	0.3	-8.50	41.0	31.13	32.50	PASS

Single Channel @ AGC Threshold+3dB								
Channel Centre Frequency (MHz)	Modulation	Signal Generator Input Level (dBm)	Input Cable Loss (dB)	Level at Spectrum Analyser (dBm)	Output Cable & Attenuator Loss (dB)	Gain (dB)	Conducted Output Power (dBm)	Result
490.00625	CW	4.34	0.3	-6.00	41.0	30.96	35.00	PASS
500.0000	CW	4.34	0.3	-5.83	41.0	31.13	35.17	PASS
499.99375	CW	4.67	0.3	-8.55	41.0	28.08	32.45	PASS

12 Noise figure

12.1 Definition

A measure of the noise generated within (or degradation in signal/noise ratio as a signal passes through) the device expressed as the ratio of signal/noise power ratio at the input to signal/noise ratio at the output.

12.2 Test Parameters

Test Location:	Element Skelmersdale
Test Chamber:	Radio Lab
Test Standard and Clause:	Part 90.219 (6)(ii)(iii)
EUT Operating Frequencies Tested:	492.5MHz, 500.0MHz, 507.50MHz
Deviations From Standard:	Client declaration
Bandwidth:	10kHz

Environmental Conditions (Normal Environment)

Temperature: 23°C	+15 °C to +35 °C (as declared)
Humidity: 32%RH	20%RH to 75%RH (as declared)
Supply: 110 V ac	

12.3 Test Limits

Part 90.219 (6) Good engineering practice must be used in regard to the radiation of intermodulation products and noise, such that interference to licensed communications systems is avoided. In the event of harmful interference caused by any given deployment, the FCC may require additional attenuation or filtering of the emissions and/or noise from signal boosters or signal booster systems, as necessary to eliminate the interference.

- (i) In general, the ERP of intermodulation products should not exceed -30 dBm in 10 kHz measurement bandwidth.
- (ii) In general, the ERP of noise within the passband should not exceed -43 dBm in 10 kHz measurement bandwidth.
- (iii) In general, the ERP of noise on spectrum more than 1 MHz outside of the passband should not exceed -70dBm in a 10 kHz measurement bandwidth.

Figure iii Test Setup

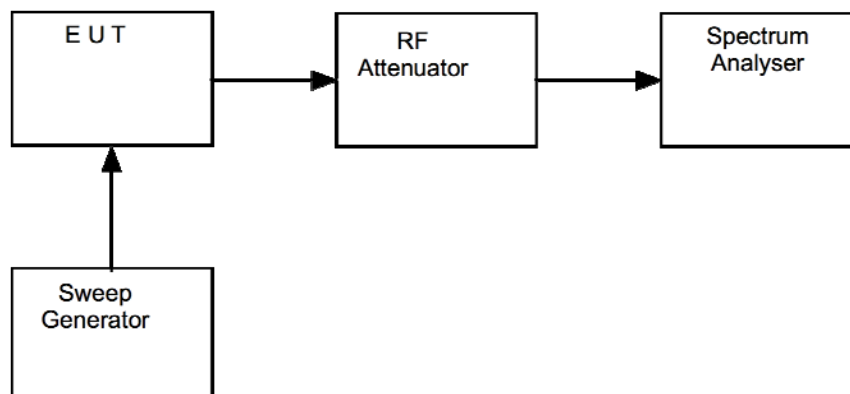

12.4 Test Equipment

Equipment Description	Manufacturer	Equipment Type	Element No	Last Cal Calibration	Calibration Period	Due For Calibration
Spectrum Analyser	R&S	FSU46	U281	07/06/2016	12	07/06/2017
Signal Generator	R&S	SMBV100A	REF916	21/03/2016	12	21/03/2017

12.5 Test Results

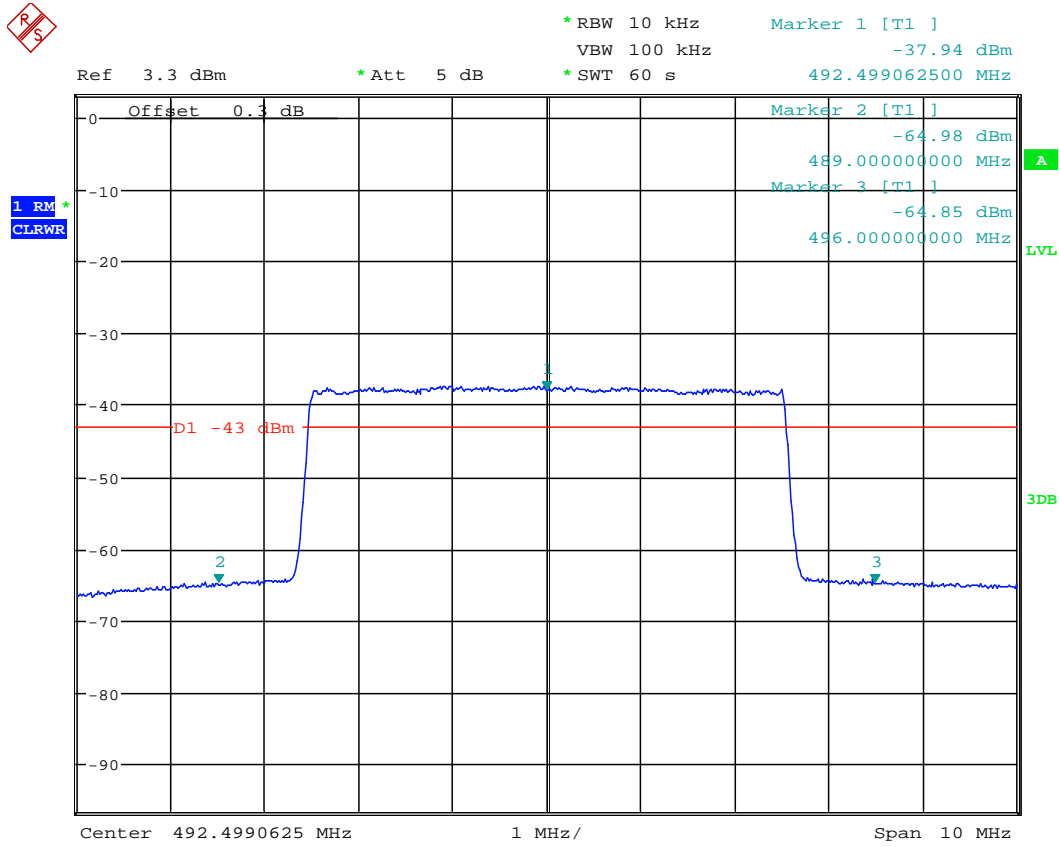

Date: 17.OCT.2016 15:49:08



Ref 3.3 dBm *Att 5 dB *RBW 10 kHz Marker 3 [T1]
*SWT 60 s VBW 100 kHz -64.92 dBm
503.50000000 MHz

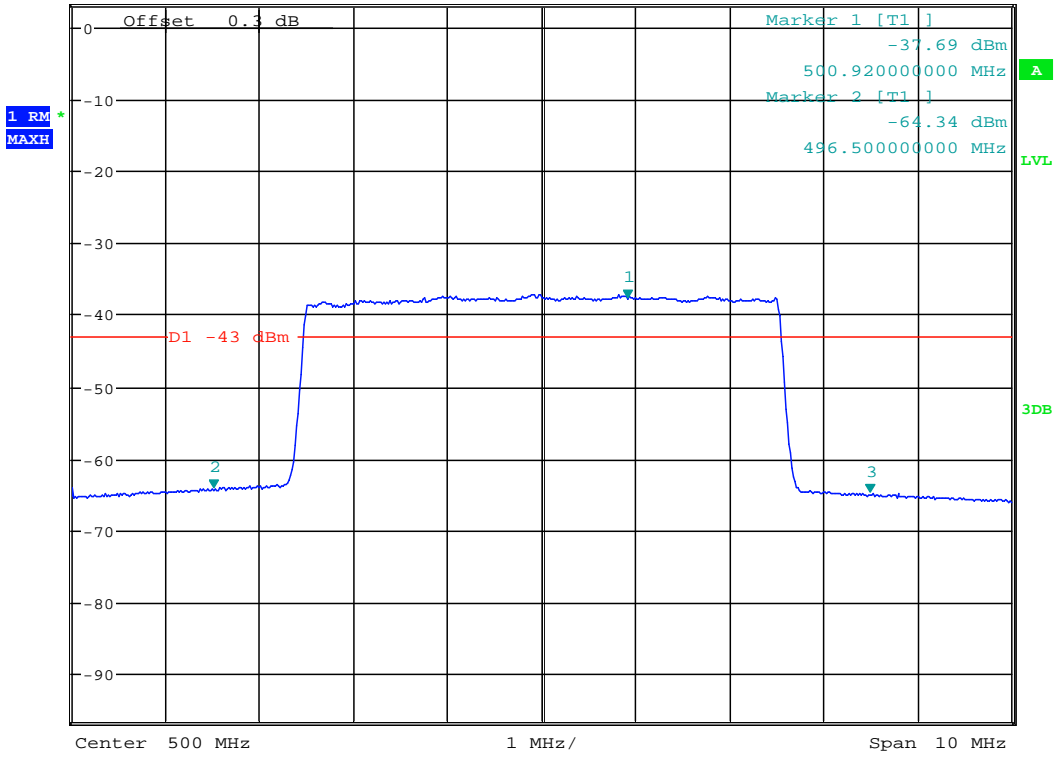

Date: 19.OCT.2016 10:38:05

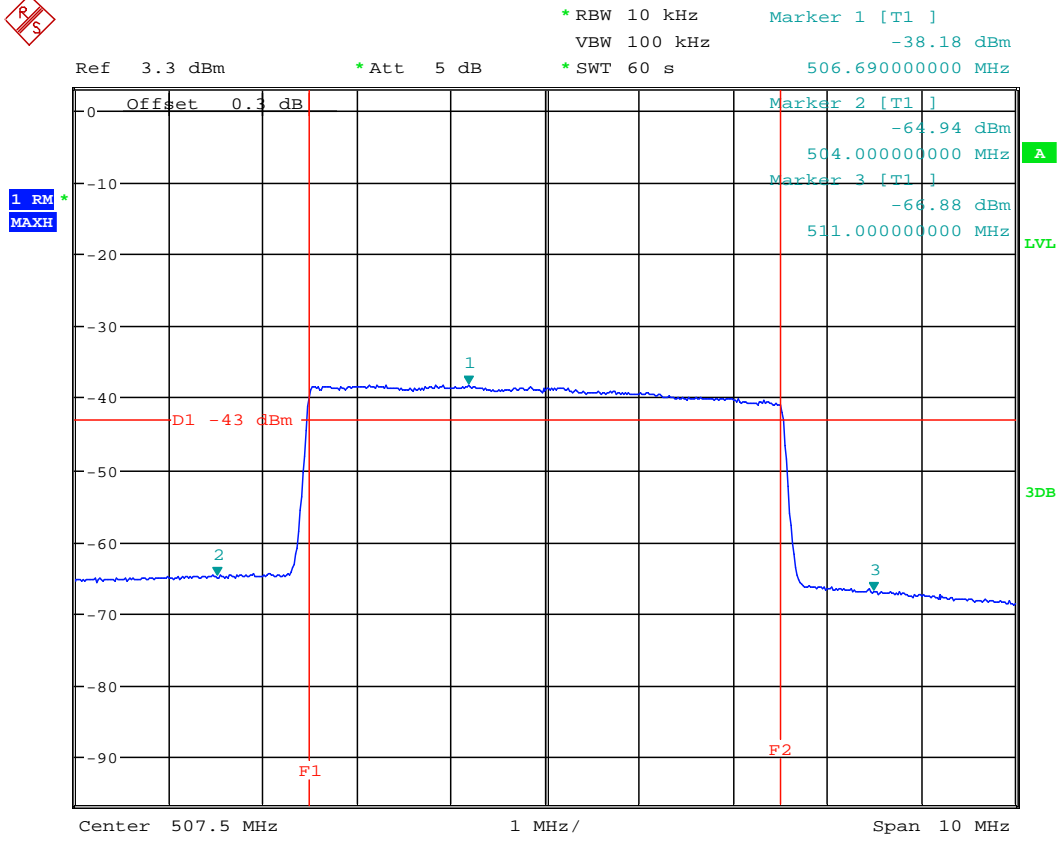

Date: 1.NOV.2016 11:20:59

12.6 Client Supplied Details of Antenna Installation

1.1.1 Antenna Installation

Installation of an antenna must comply with the FCC RF exposure requirements. The antenna used for this transmitter must be mounted on permanent structures.

The FCC regulations mandate that the ERP of type B signal boosters should not exceed 5W, this is equivalent to 8.2W EIRP.

Therefore the max antenna gain allowed for this type of signal booster should be limited to the values given by equation 1 (below) for the service antenna.

Equation (1) - Max SERVICE antenna gain

Max SERVICE antenna gain (dBi) = 39.1 – (37dBm - # of antennas in dB – cable losses in dB).

For example:

No. of Antennas	Cable Losses	Max Allowed Antenna Gain
4	3	39.1 - (37-6-3) =11.1dBi
1	3	39.1- (37-0-3) = 5.1dbi
10	3	39.1- (37-10-3) = 15.1dbi

1.1.2 Compliance with FCC deployment rule regarding the radiation of noise and intermodulation product

Good engineering practice must be used in regard to the signal booster's radiation of intermodulation products and noise. Thus, the gain of the signal booster should be set so that the ERP of the output of intermodulation products from the signal booster should not exceed the level of -30 dBm in 10 kHz measurement bandwidth and noise from the signal booster should not exceed the level of -43 dBm in 10 kHz measurement bandwidth.

In the event that the intermodulation or noise level measured exceeds the aforementioned values, the signal booster gain should be decreased accordingly.

In general, the ERP of noise on a spectrum more than 1 MHz outside of the pass band should not exceed -70 dBm in a 10 kHz measurement bandwidth.

The BSF-3604 61-103001 Repeater has a noise level of -64 dBm in 10 kHz measurement at 1 MHz spectrum outside the passband of the signal booster, worst case intermodulation products at around -15 dBm in a 10 kHz bandwidth and an in-band noise level at around -37 dBm in a 10 kHz bandwidth. Therefore, the noise or intermodulation product at the antenna input port should be calculated based on equation (2).

Equation (2) - Input Noise or intermodulation product to service antenna

Input Noise to service antenna:

-XX dBm + Service Antenna gain – Antenna splitter losses in dB – cable loss in dB

Example: Intermodulation product

Signal booster connected to 10 service antennas with a 100m long ½ inch cable. Losses of such a cable with the connectors = ~ 12dB

Assuming 10 service antennas: antenna splitter losses = 11 dB

Based on equation (2) Input antenna noise (to the antenna) = -15-12 -11= -38 dBm ERP

13 Retransmitted masks

13.1 Definition

The emission mask is the required attenuation relative to the channel power up to 250% of the channel bandwidth. For frequencies greater than 250% of the authorized bandwidth, refer to spurious emission measurement.

13.2 Test Parameters

Test Location:	Element Skelmersdale
Test Chamber:	Radio lab
Test Standard and Clause:	KDB 935210 D05 v01r01, clause 4.4
EUT Operating Frequencies Tested:	492.5MHz, 500MHz, 507.5MHz
Source Modulations:	16K0F3E, 11K3F3E, 4K00F1E,8k10F1E,5k7G1E
Source Levels:	1.35dBm, 4.35 dBm (AGC threshold and 3dB above)
Deviations From Standard:	None
Bandwidth, RBW:	Various, see plots. VBW =3xRBW
Span:	(2-5 times OBW)
Measurement Detector	Peak; Max-Hold.

Environmental Conditions (Normal Environment)

Temperature: 23°C	+15 °C to +35 °C (as declared)
Humidity: 28%RH	20%RH to 75%RH (as declared)
Supply: 110 Vac	

13.3 Test Limits

13.3.1 FCC 47CFR90

- (i) There is no change in the occupied bandwidth of the retransmitted signals.
- (ii) The retransmitted signals continue to meet the unwanted emissions limits of §90.210 applicable to the corresponding received signals (assuming that these received signals meet the applicable unwanted emissions limits by a reasonable margin).

APPLICABLE EMISSION MASKS

Frequency band (MHz)	Mask for equipment with audio low pass filter	Mask for equipment without audio low pass filter
Below 25 1	A or B	A or C
25–50	B	C
72–76	B	C
150–174 2	B, D, or E	C, D or E
150 paging only	B	C
220–222	F	F
421–5122 5	B, D, or E	C, D, or E
450 paging only	B	G
806–809/851–854	B	H
809–824/854–8693 5	B	G
896–901/935–940	I	J
902–928	K	K
929–930	B	G
4940–4990 MHz	L or M	L or M
5850–5925 4	B	C
All other bands		

- 1 Equipment using single sideband J3E emission must meet the requirements of Emission Mask A. Equipment using other emissions must meet the requirements of Emission Mask B or C, as applicable.
- 2 Equipment designed to operate with a 25 kHz channel bandwidth must meet the requirements of Emission Mask B or C, as applicable. Equipment designed to operate with a 12.5kHz channel bandwidth must meet the requirements of Emission Mask D, and equipment designed to operate with a 6.25kHz channel bandwidth must meet the requirements of Emission Mask E.
- 3 Equipment used in this licensed to EA or non-EA systems shall comply with the emission mask provisions of § 90.691 of this chapter.
- 4 DSRCS Roadside Units equipment in the 5850–5925 MHz band is governed under subpart M of this part.
- 5 Equipment may alternatively meet the Adjacent Channel Power limits of § 90.221.

(c) **Emission Mask C.** For transmitters that are not equipped with an audio low-pass filter, the power of any emission must be attenuated below the unmodulated carrier output power (P) as follows: (1) On any frequency removed from the center of the authorized bandwidth by a displacement frequency (f_d in kHz) of more than 5 kHz, but not more than 10 kHz: At least $83 \log(f_d/5)$ dB; (2) On any frequency removed from the center of the authorized bandwidth by a displacement frequency (f_d in kHz) of more than 10 kHz, but not more than 250 percent of the authorized bandwidth: At least $29 \log(f_d/11)$ dB or 50dB, whichever is the lesser attenuation; (3) On any frequency removed from the center of the authorized bandwidth by more than 250 percent of the authorized bandwidth: At least $43 + 10 \log(P)$ dB.

(d) **Emission Mask D—12.5 kHz channel bandwidth equipment.** For transmitters designed to operate with a 12.5 kHz channel bandwidth, any emission must be attenuated below the power (P) of the highest emission contained within the authorized bandwidth as follows: (1) On any frequency from the center of the authorized bandwidth f_0 to 5.625 kHz removed from f_0 : Zero dB. (2) On any frequency removed from the center of the authorized bandwidth by a displacement frequency (f_d in kHz) of more than 5.625 kHz but no more than 12.5 kHz: At least $7.27(f_d - 2.88 \text{ kHz})$ dB. (3) On any frequency removed from the center of the authorized bandwidth by a displacement frequency (f_d in kHz) of more than 12.5 kHz: At least $50 + 10 \log(P)$ dB or 70 dB, whichever is the lesser attenuation. (4) The reference level for showing compliance with the emission mask shall be established using a resolution bandwidth sufficiently wide (usually two or three times the channel bandwidth) to capture the true peak emission of the equipment under test. In order to show compliance with the emission mask up to and including 50 kHz removed from the edge of the authorized bandwidth, adjust the resolution bandwidth to 100 Hz with the measuring instrument in a peak hold mode. A sufficient number of sweeps must be measured to insure that the emission profile is developed. If video filtering is used, its bandwidth must not be less than the instrument resolution bandwidth. For emissions beyond 50 kHz from the edge of the authorized bandwidth, see paragraph (o) of this section. If it can be shown that use of the above instrumentation settings do not accurately represent the true interference potential of the equipment under test, an alternate procedure may be used provided prior Commission approval is obtained.

(e) **Emission Mask E—6.25 kHz or less channel bandwidth equipment.** For transmitters designed to operate with a 6.25 kHz or less bandwidth, any emission must be attenuated below the power (P) of the highest emission contained within the authorized bandwidth as follows:

(1) On any frequency from the center of the authorized bandwidth f_0 to 3.0 kHz removed from f_0 : Zero dB

(2) On any frequency removed from the center of the authorized bandwidth by a displacement frequency (f_d in kHz) of more than 3.0 kHz but no more than 4.6 kHz: At least $30 + 16.67(f_d - 3 \text{ kHz})$ or $55 + 10 \log(P)$ or 65 dB, whichever is the lesser attenuation.

(3) On any frequency removed from the center of the authorized bandwidth by more than 4.6 kHz: At least $55 + 10 \log(P)$ or 65 dB, whichever is the lesser attenuation.

(4) The reference level for showing compliance with the emission mask shall be established using a resolution bandwidth sufficiently wide (usually two or three times the channel bandwidth) to capture the true peak emission of the equipment under test. In order to show compliance with the emission mask up to and including 50 kHz removed from the edge of the authorized bandwidth, adjust the resolution bandwidth to 100 Hz with the measuring instrument in a peak hold mode. A sufficient number of sweeps must be measured to insure that the emission profile is developed. If video filtering is used, its bandwidth must not be less than the instrument resolution bandwidth. For emissions beyond 50 kHz from the edge of the authorized bandwidth, see paragraph (o) of this section. If it can be shown that use of the above instrumentation settings do not accurately represent the true interference potential of the equipment under test, an alternate procedure may be used provided prior Commission approval is obtained.

13.4 Test Method

With the EUT setup as per section 9 of this report and connected as per Figure iv, the RF spectrum mask was measured on a spectrum analyser and compared to the signal generator output as shown on the plots.

The measurements were performed with EUT set at its nominal / maximum gain.

Figure iv Test Setup

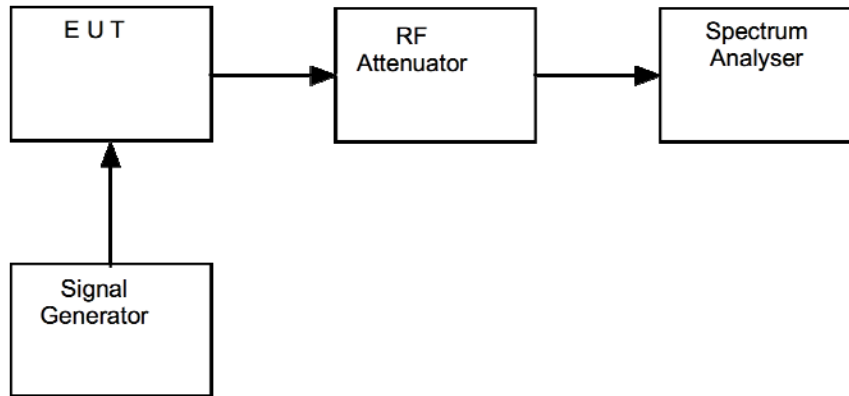

13.5 Test Equipment

<i>Equipment Description</i>	<i>Manufacturer</i>	<i>Equipment Type</i>	<i>Element No</i>	<i>Last Cal Calibration</i>	<i>Calibration Period</i>	<i>Due For Calibration</i>
Spectrum Analyser	R&S	FSU46	U281	07/06/2016	12	07/06/2017
Signal Generator	R&S	SMBV100A	REF916	21/03/2016	12	21/03/2017
Signal Generator	Marconi	2042	L176	04/01/2016	12	04/01/2017

13.6 Test Results

The above plots depicting the output spectra show no obvious distortion visible when compared to the input signal.

Bottom 5MHz Band

FM 25kHz Analogue Voice

16k0F3E AGC

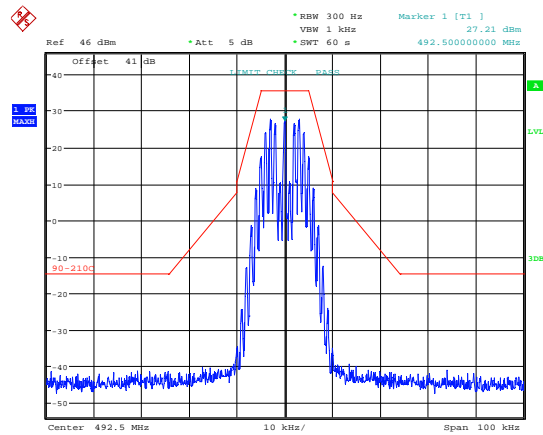

Date: 13.OCT.2016 12:42:05

16k0F3E AGC+3dB

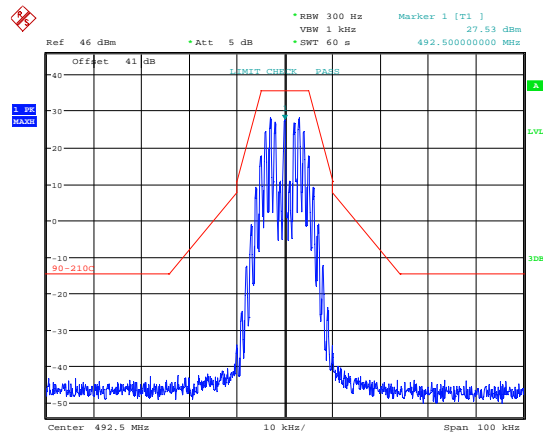

Date: 13.OCT.2016 12:43:31

16k0F3E Signal Generator only

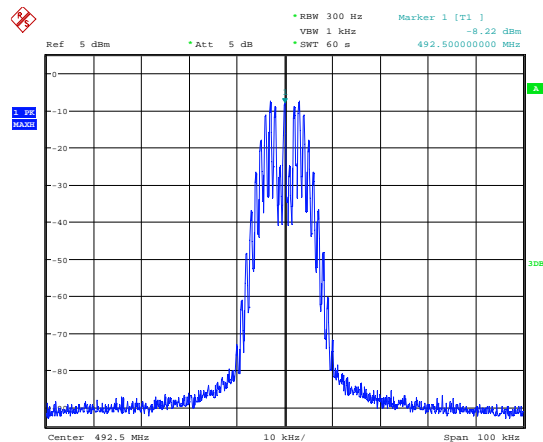

Date: 13.OCT.2016 12:48:51

The above plots depicting the output spectra show no obvious distortion visible when compared to the input signal.

Bottom 5MHz Band

FM 12.5kHz Analogue Voice

11k3F3E AGC

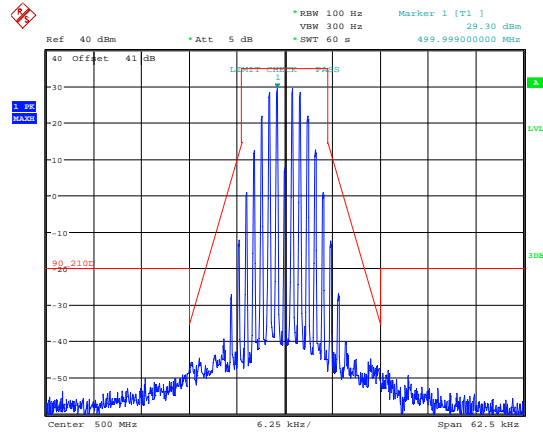

Date: 19.OCT.2016 11:55:58

11k3F3E AGC+3dB

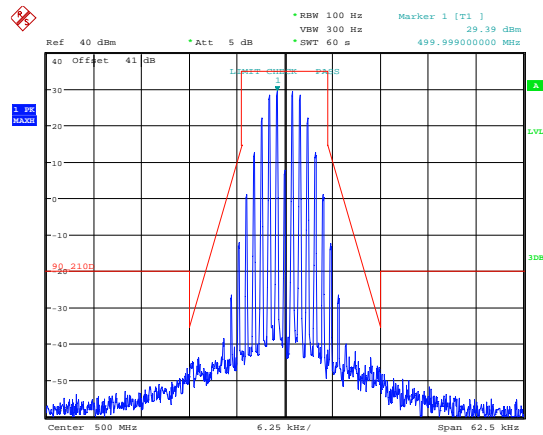

Date: 19.OCT.2016 11:57:40

11k3F3E Signal Generator only

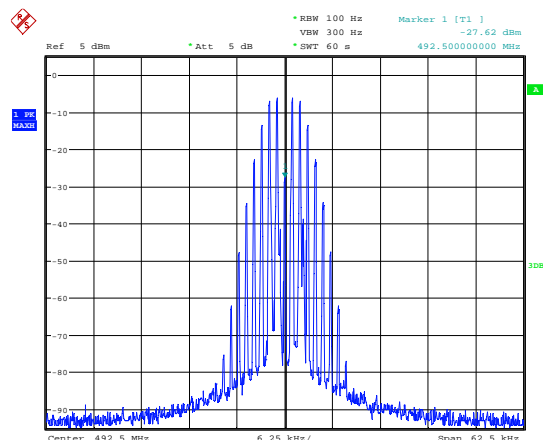

Date: 13.OCT.2016 12:53:26

The above plots depicting the output spectra show no obvious distortion visible when compared to the input signal.

Bottom 5MHz Band

FM 6.25kHz Analogue Voice

4k00F1E AGC

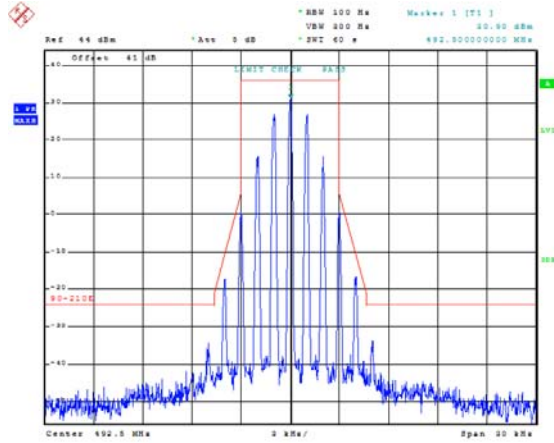

Date: 17.OCT.2016 12:14:40

4k00F1E AGC+3dB

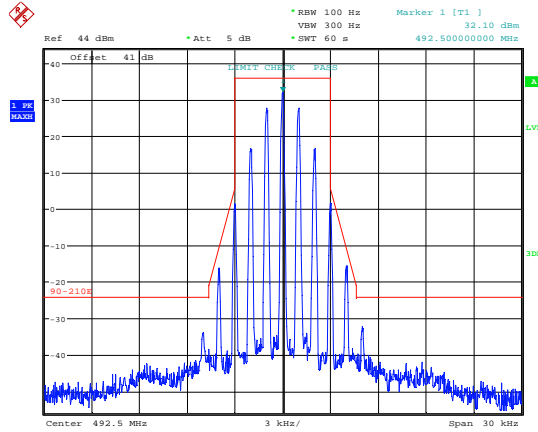

Date: 17.OCT.2016 12:16:44

4k00F1E Signal Generator only

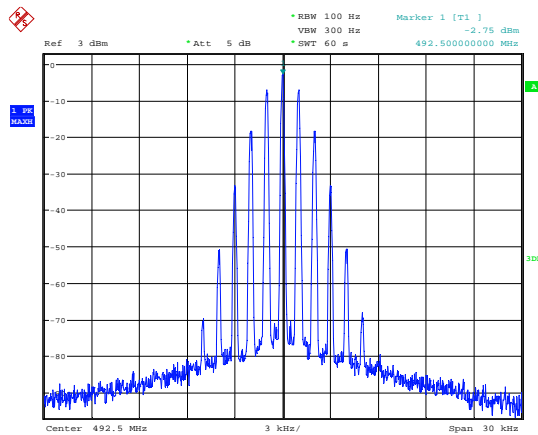

Date: 17.OCT.2016 12:20:10

The above plots depicting the output spectra show no obvious distortion visible when compared to the input signal.

Bottom 5MHz Band

P25 C4FM

8k10F1E AGC

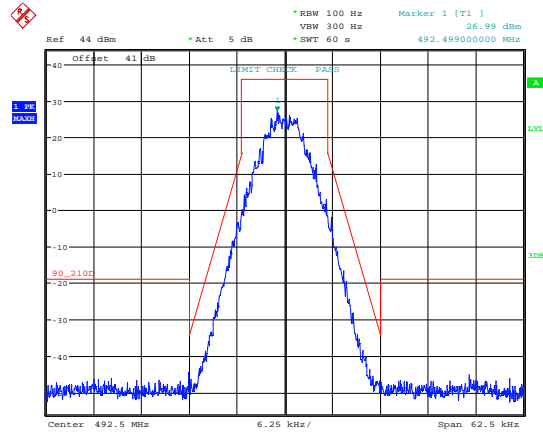

Date: 17.OCT.2016 14:49:48

8k10F1E AGC+3dB

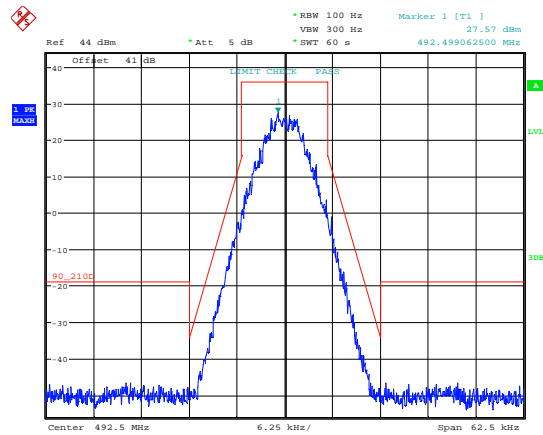

Date: 17.OCT.2016 15:44:01

8k10F1E Signal Generator only

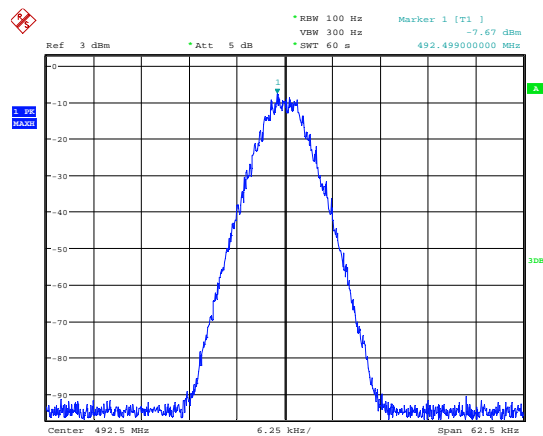

Date: 17.OCT.2016 14:43:54

The above plots depicting the output spectra show no obvious distortion visible when compared to the input signal.

Bottom 5MHz Band

P25 CQPSK

5k7G1E AGC

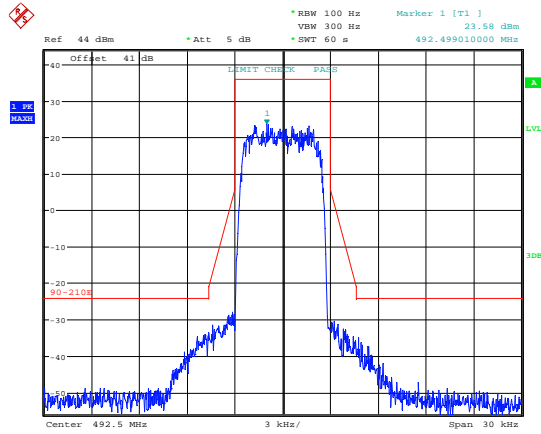

Date: 17.OCT.2016 14:31:45

5k7G1E AGC+3dB

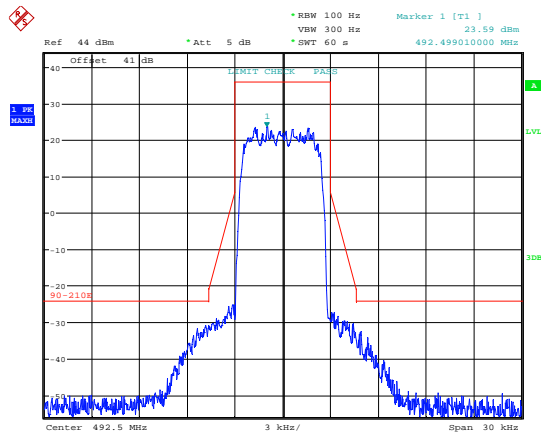

Date: 17.OCT.2016 14:33:31

Signal Generator 5k7G1E

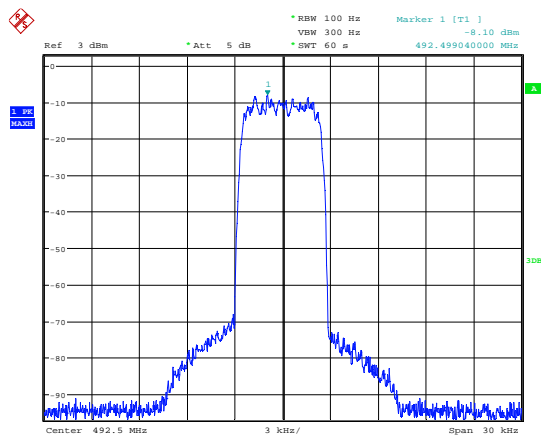

Date: 17.OCT.2016 14:37:47

The above plots depicting the output spectra show no obvious distortion visible when compared to the input signal.

Mid 5MHz Band

FM 25kHz Analogue Voice

16k0F3E AGC

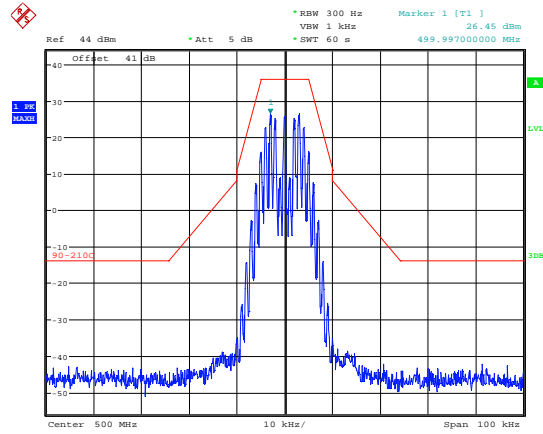

Date: 19.OCT.2016 11:03:43

16k0F3E AGC+3dB

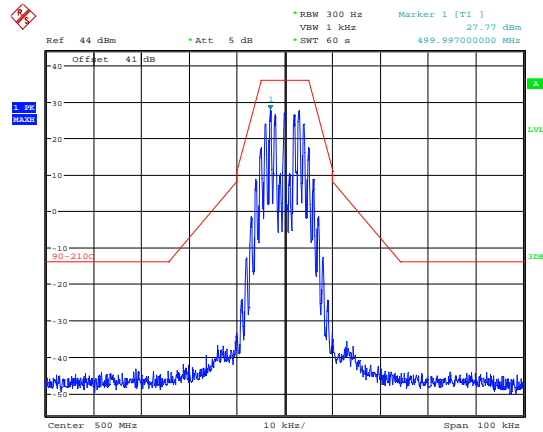

Date: 19.OCT.2016 11:02:19

16k0F3E Signal Generator

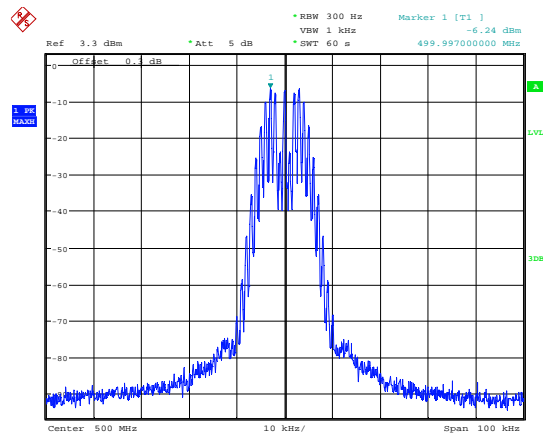

Date: 19.OCT.2016 11:07:16

The above plots depicting the output spectra show no obvious distortion visible when compared to the input signal.

Mid 5MHz Band

FM 12.5kHz Analogue Voice

11k3F3E AGC

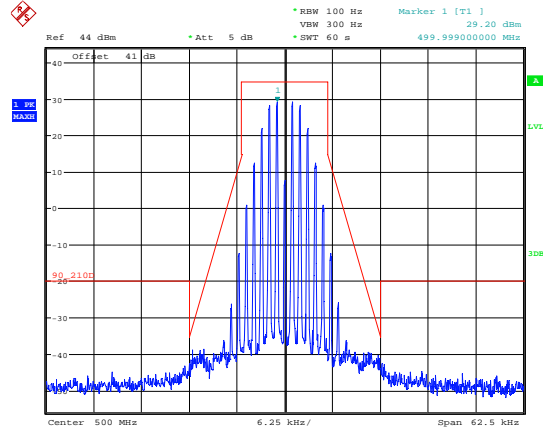

Date: 19.OCT.2016 11:20:34

11k3F3E AGC+3dB

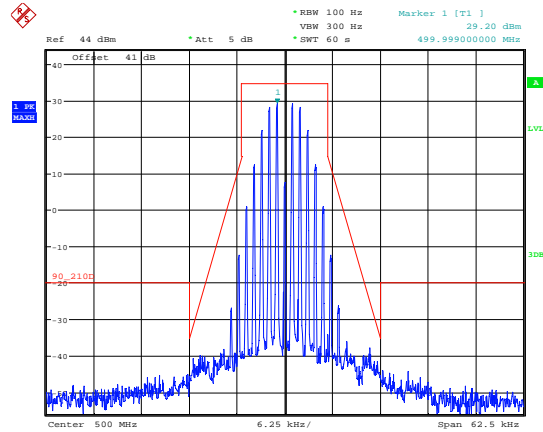

Date: 19.OCT.2016 11:22:35

11k3F3E Signal Generator

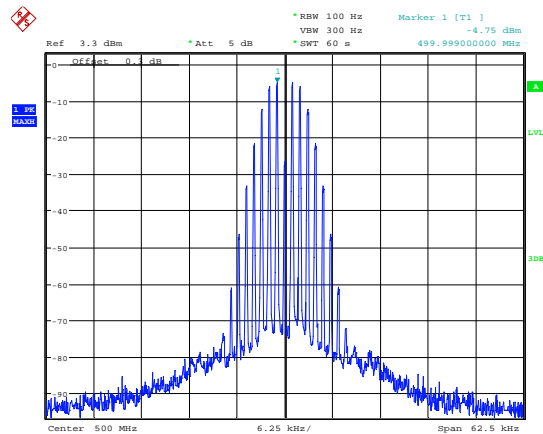

Date: 19.OCT.2016 11:27:25

The above plots depicting the output spectra show no obvious distortion visible when compared to the input signal.

Mid 5MHz Band

FM 6.25kHz Analogue Voice

4k00F1E AGC

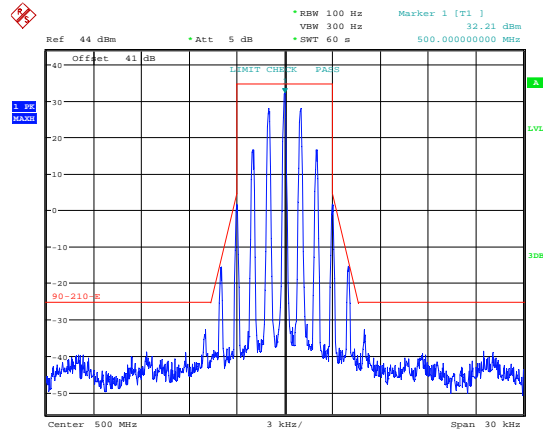

Date: 1.NOV.2016 14:50:42

4k00F1E AGC+3dB

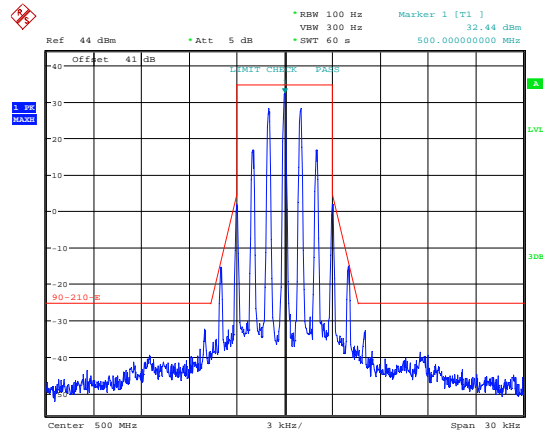

Date: 1.NOV.2016 14:43:12

4k00F1E Signal Generator

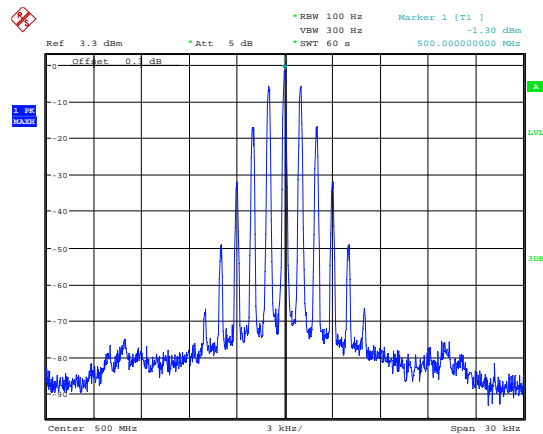

Date: 19.OCT.2016 11:30:05

The above plots depicting the output spectra show no obvious distortion visible when compared to the input signal.

Mid 5MHz Band

P25 C4FM

8k10F1E AGC

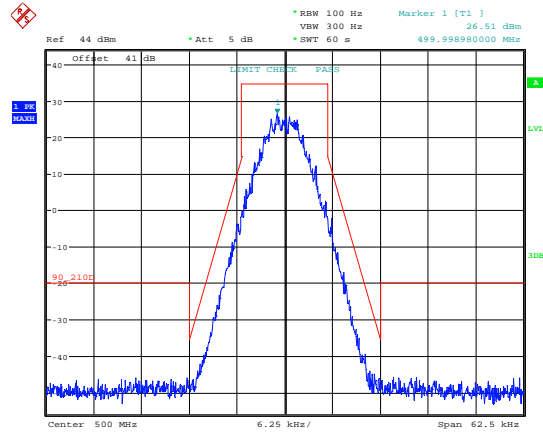

Date: 18.OCT.2016 17:17:39

8k10F1E AGC+3dB

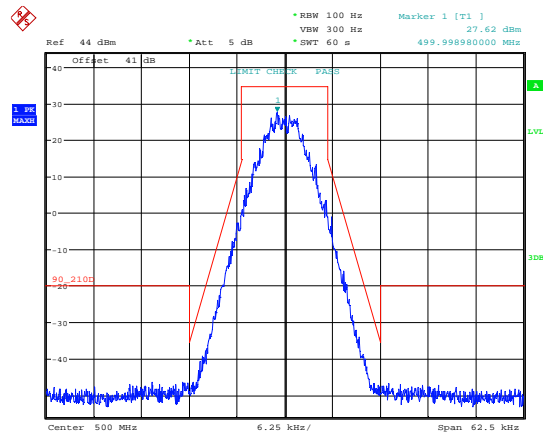

Date: 18.OCT.2016 17:14:08

8k10F1E Signal Generator

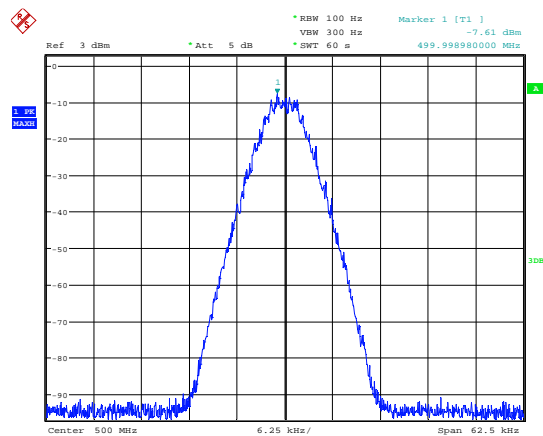

Date: 18.OCT.2016 17:21:22

The above plots depicting the output spectra show no obvious distortion visible when compared to the input signal.

Mid 5MHz Band

P25 CQPSK

5k7G1E AGC

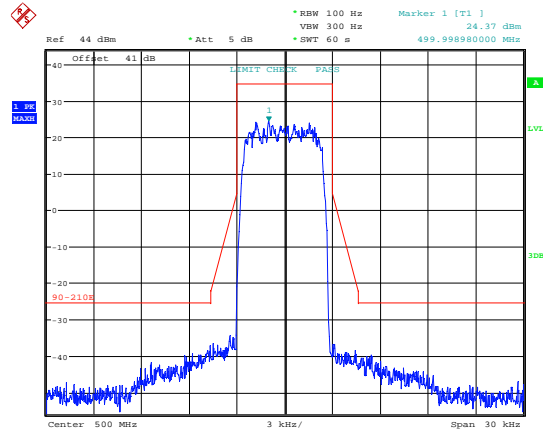

Date: 18.OCT.2016 17:01:45

5k7G1E AGC+3dB

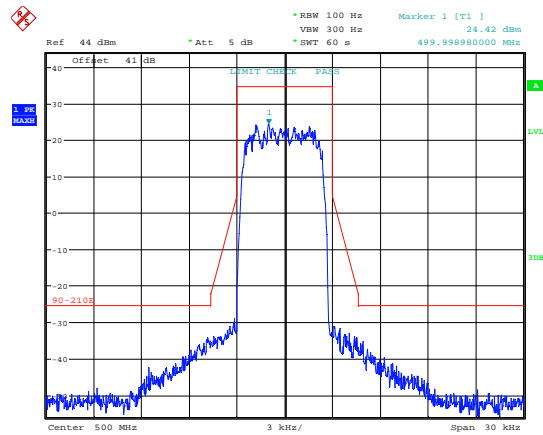

Date: 18.OCT.2016 17:04:03

5k7G1E Signal Generator

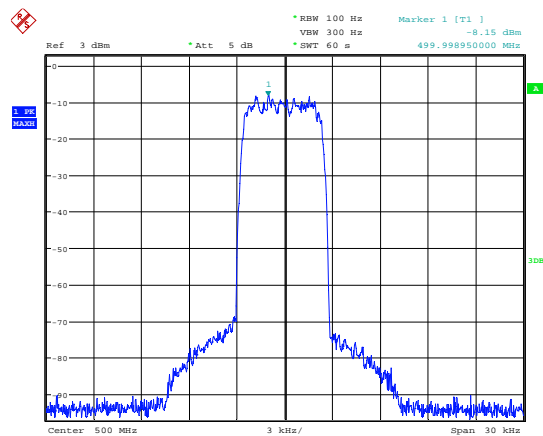

Date: 18.OCT.2016 16:32:03

The above plots depicting the output spectra show no obvious distortion visible when compared to the input signal.

Top 5MHz Band

FM 25kHz Analogue Voice

16k0F3E AGC

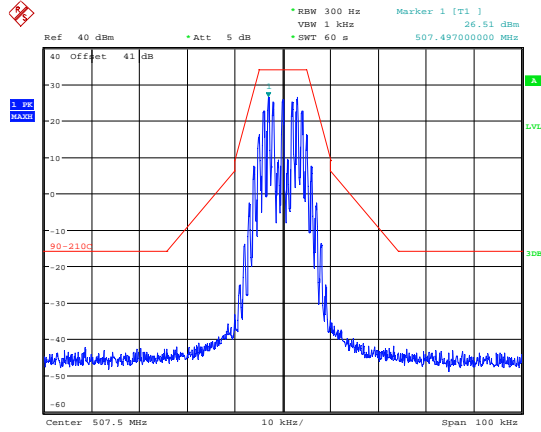

Date: 31.OCT.2016 17:40:28

16k0F3E AGC+3dB

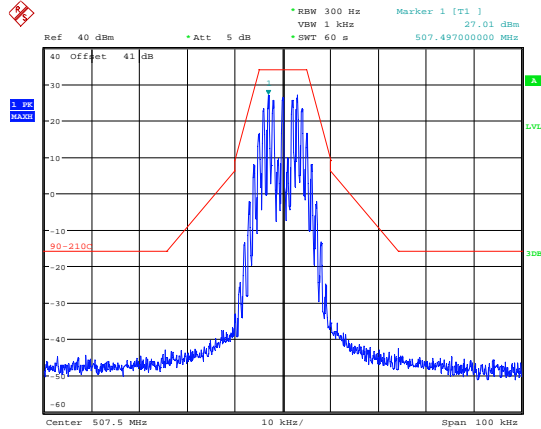

Date: 31.OCT.2016 17:42:28

16k0F3E Signal Generator

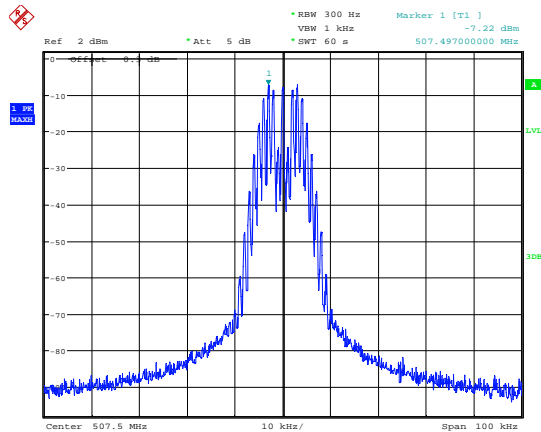

Date: 31.OCT.2016 17:08:24

The above plots depicting the output spectra show no obvious distortion visible when compared to the input signal.

Top 5MHz Band

FM 12.5kHz Analogue Voice

11k3F3E AGC

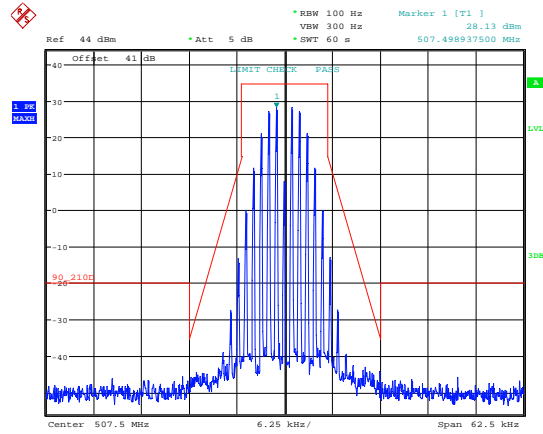

Date: 31.OCT.2016 16:45:11

11k3F3E AGC+3dB

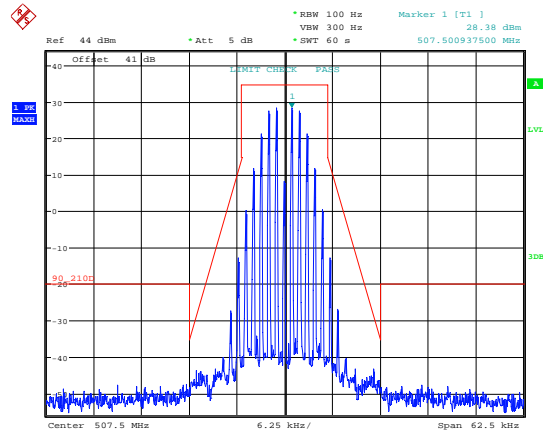

Date: 31.OCT.2016 16:48:15

11k3F3E Signal Generator

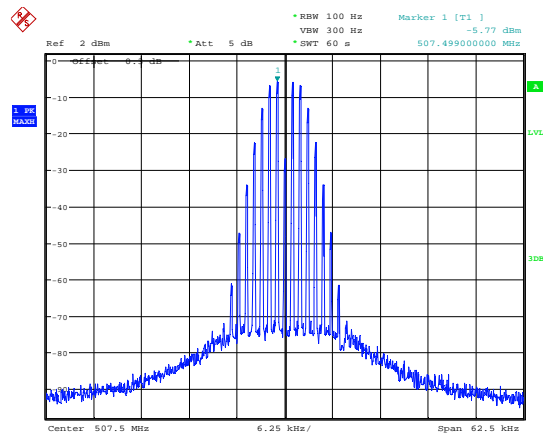

Date: 31.OCT.2016 17:03:09

The above plots depicting the output spectra show no obvious distortion visible when compared to the input signal.

Top 5MHz Band

FM 6.25kHz Analogue Voice

4k00F1E AGC

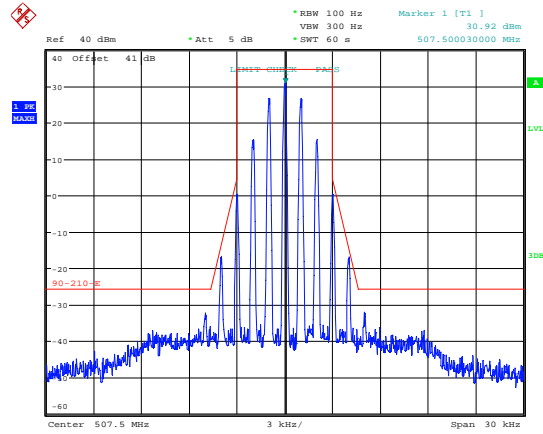

Date: 31.OCT.2016 18:04:36

4k00F1E AGC+3dB

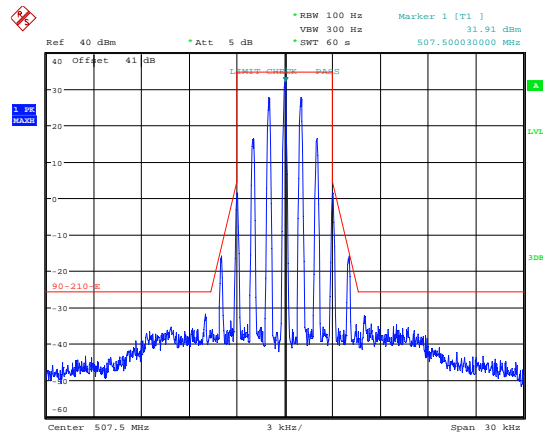

Date: 31.OCT.2016 18:08:47

4k00F1E Signal Generator

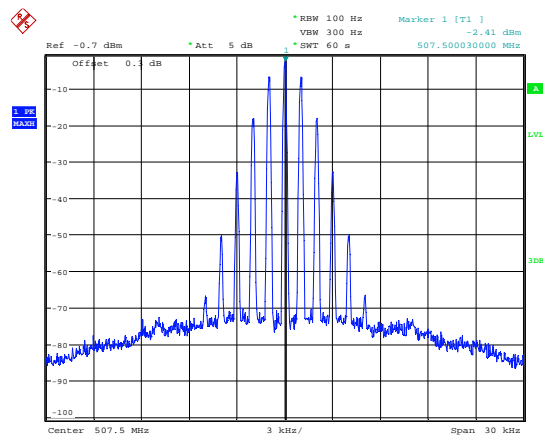

Date: 1.NOV.2016 10:16:37

The above plots depicting the output spectra show no obvious distortion visible when compared to the input signal.

Top 5MHz Band

P25 C4FM

8k10F1E AGC

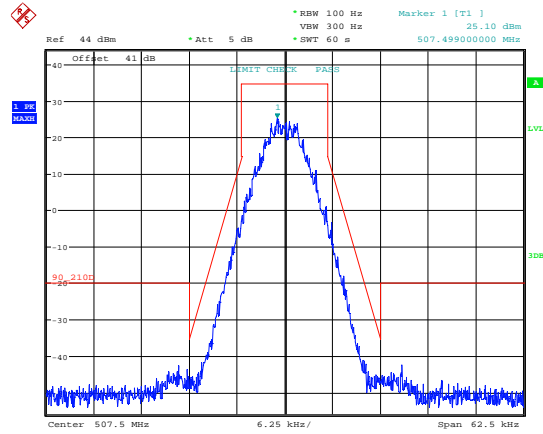

Date: 1.NOV.2016 10:44:32

8k10F1E AGC+3dB

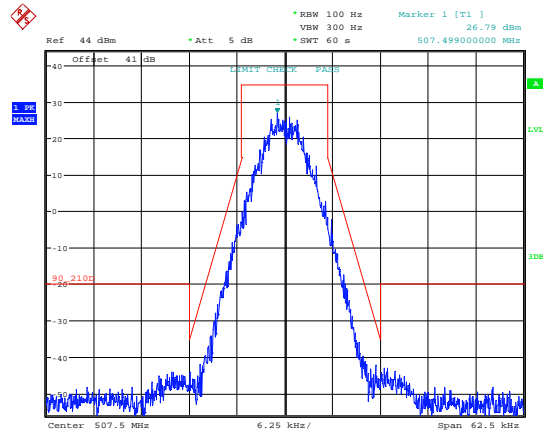

Date: 1.NOV.2016 10:45:48

8k10F1E Signal Generator

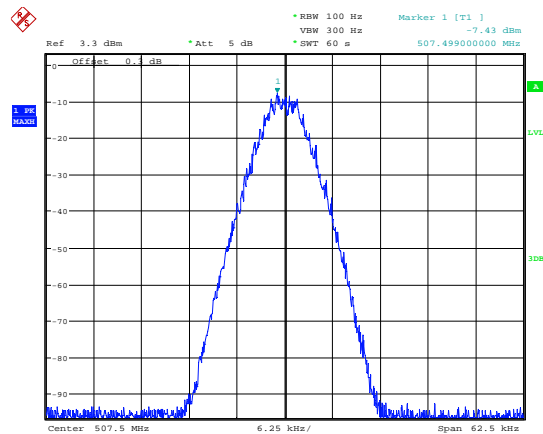

Date: 1.NOV.2016 10:48:21

The above plots depicting the output spectra show no obvious distortion visible when compared to the input signal.

Top 5MHz Band

P25 CQPSK

5k7G1E AGC

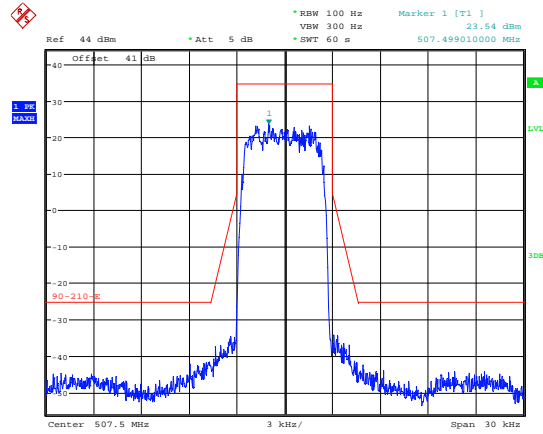

Date: 1.NOV.2016 11:08:53

5k7G1E AGC+3dB

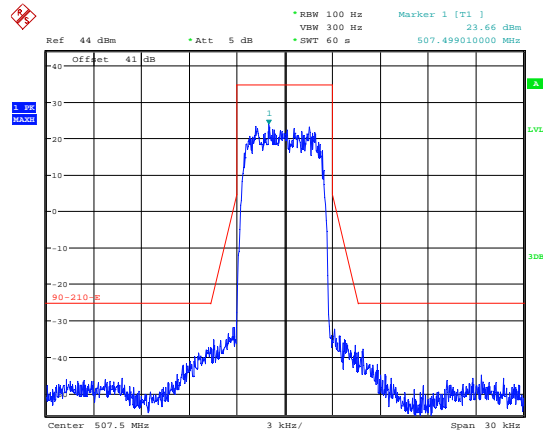

Date: 1.NOV.2016 11:10:21

5k7G1E Signal Generator

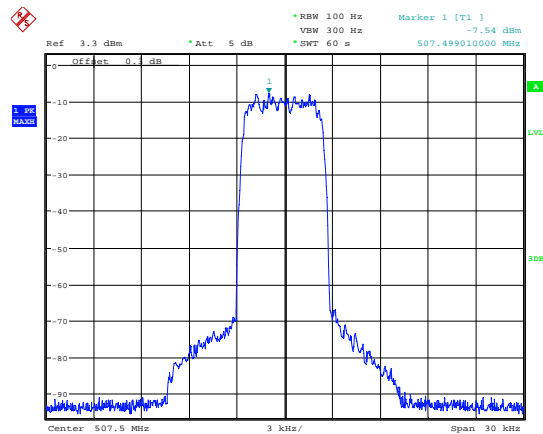

Date: 1.NOV.2016 11:04:09

The above plots depicting the output spectra show no obvious distortion visible when compared to the input signal.

14 Passband gain and bandwidth

14.1 Definition

The passband is the range of frequencies over which the booster is intended to apply gain. Each booster may include one or more passbands. The bandwidth of each passband is defined by two points either side of the band where the gain has fallen by 20dB from maximum.

14.2 Test Parameters

Test Location:	Element Skelmersdale
Test Chamber:	Radio Lab
Test Standard and Clause:	KDB 935210 D05 v01r01 , Clause 4.3
Channels:	Bottom/Mid/Top 5MHz bands (+/-250% declared pass band)
Source Modulation:	CW
Source Level:	-1.66 dBm (3dB below the AGC threshold)
Sweep Set-Up:	50kHz steps; 20ms dwell.
Deviations From Standard:	None
Bandwidth:	RBW 50 kHz (1-5% pass band); VBW 200kHz (3xRBW).
Measurement Detector	Peak; Max-Hold.

Environmental Conditions (Normal Environment)

Temperature: 23°C	+15 °C to +35 °C (as declared)
Humidity: 34%RH	20%RH to 75%RH (as declared)
Supply: 110 V ac	

14.3 Test Limits

14.3.1 FCC 47CFR90.

Not specified.

14.4 Test Method

With the EUT setup as per section 9 of this report and connected as per Figure v, the 20dB bandwidth of the EUT was measured on a spectrum analyser.

The measurements were performed with EUT set at its nominal / maximum gain.

Figure v Test Setup

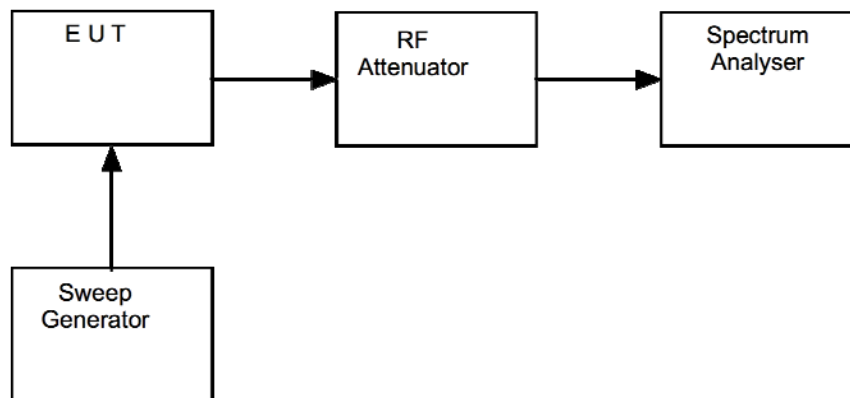

14.5 Test Equipment

<i>Equipment Description</i>	<i>Manufacturer</i>	<i>Equipment Type</i>	<i>Element No</i>	<i>Last Cal Calibration</i>	<i>Calibration Period</i>	<i>Due For Calibration</i>
Spectrum Analyser	R&S	FSU46	U281	07/06/2016	12	07/06/2017
Signal Generator	R&S	SMBV100A	REF916	21/03/2016	12	21/03/2017

14.6 Test Results

Bottom 5MHz operating band

Pass Band Nominal Centre (MHz)	Lower Mkr Frequency (MHz)	Upper Mkr Frequency (MHz)	20dB Bandwidth (MHz)	Result
492.50	489.875000	495.150000	5.275	PASS

Middle 5MHz operating band

Pass Band Nominal Centre (MHz)	Lower Mkr Frequency (MHz)	Upper Mkr Frequency (MHz)	20dB Bandwidth (MHz)	Result
500.00	497.385000	502.640000	5.255	PASS

Top 5MHz operating band

Pass Band Nominal Centre (MHz)	Lower Mkr Frequency (MHz)	Upper Mkr Frequency (MHz)	20dB Bandwidth (MHz)	Result
507.50	504.875000	510.150000	5.275	PASS

Top 5MHz operating band

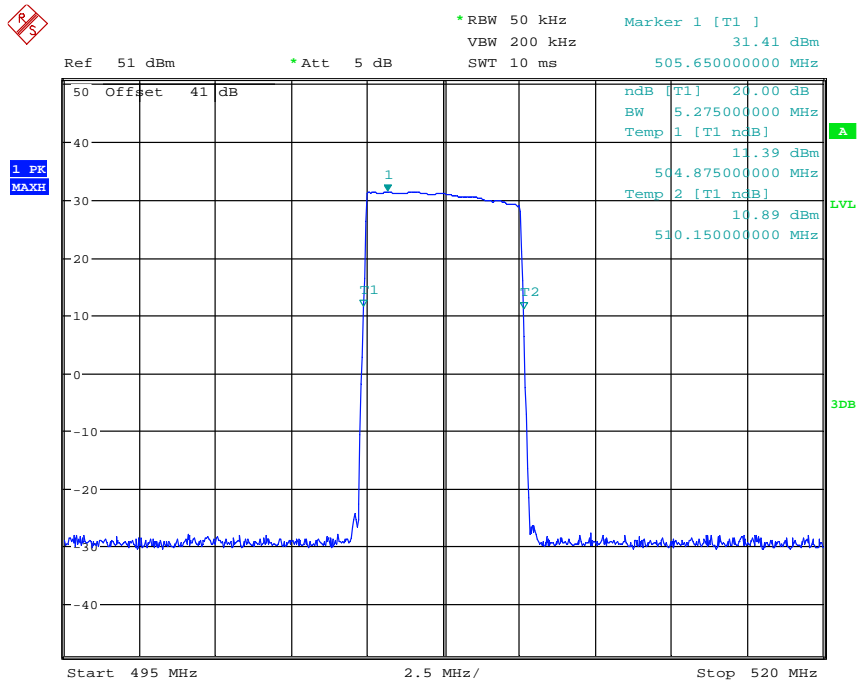

Date: 31.OCT.2016 16:03:00

15 Spurious emissions at antenna terminals

15.1 Definition

Emission on a frequency or frequencies which are outside the necessary bandwidth and the level of which may be reduced without affecting the corresponding transmission of information. Spurious emissions include harmonic emissions, parasitic emissions, intermodulation products and frequency conversion products, but exclude out-of-band emissions.

15.2 Test Parameters

Test Location:	Element Skelmersdale
Test Chamber:	Radio Lab
Test Standard and Clause:	KDB 935210 D05 v01r01, clause 4.7.3
Source Modulations:	CW,
Source Level:	1.67 dBm (maximum input rating / AGC threshold)
Deviations From Standard:	None
Bandwidth:	RBW 100 kHz; VBW 3xRBW
Frequency Range Examined:	9 kHz – 6 GHz (10 x highest passband)
Measurement Detector	Peak

Environmental Conditions (Normal Environment)

Temperature: 24°C	+15 °C to +35 °C (as declared)
Humidity: 32%RH	20%RH to 75%RH (as declared)
Supply: 110 V ac	

15.3 Test Limits

15.3.1 47CFR90

Spurious emissions from a signal booster must not exceed -13 dBm within any 100 kHz measurement bandwidth.

15.4 Test Method

Single Channel:

With the EUT setup as per section 9 of this report and connected as per Figure vi, the emissions of the EUT were calculated by taking into account any cable and attenuator calibration factors. It was confirmed that at the maximum input level there was no compression.

Figure vi Test Setup

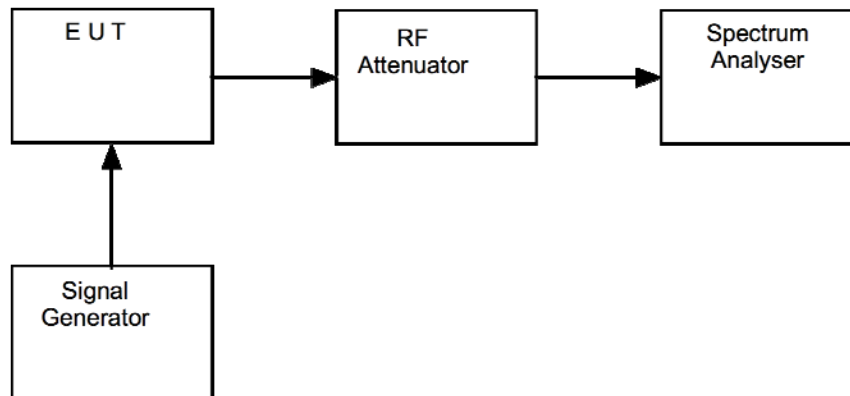

15.5 Test Equipment

<i>Equipment Description</i>	<i>Manufacturer</i>	<i>Equipment Type</i>	<i>Element No</i>	<i>Last Cal Calibration</i>	<i>Calibration Period</i>	<i>Due For Calibration</i>
Spectrum Analyser	R&S	FSU46	U281	07/06/2016	12	07/06/2017
Signal Generator	R&S	SMBV100A	REF916	21/03/2016	12	21/03/2017

15.6 Test Results

15.6.1 Out-of-band

<i>Downlink</i>							
<i>Operating Frequency (MHz)</i>	<i>Frequency Range (MHz)</i>	<i>Freq. of Emission (MHz)</i>	<i>Measured Level (dBm)</i>	<i>Attenuator & Cable Losses (dB)</i>	<i>Spurious Emission Level (dBm)</i>	<i>Limit (dBm)</i>	<i>Result</i>
496.250	0.009 – 6,000	No significant Emissions within 20dB of the limit				-13.0	PASS
500.000	0.009 – 6,000	No significant Emissions within 20dB of the limit				-13.0	PASS
509.99375	0.009 – 6,000	No significant Emissions within 20dB of the limit				-13.0	PASS

Low channel bottom 5MHz band 9-150kHz

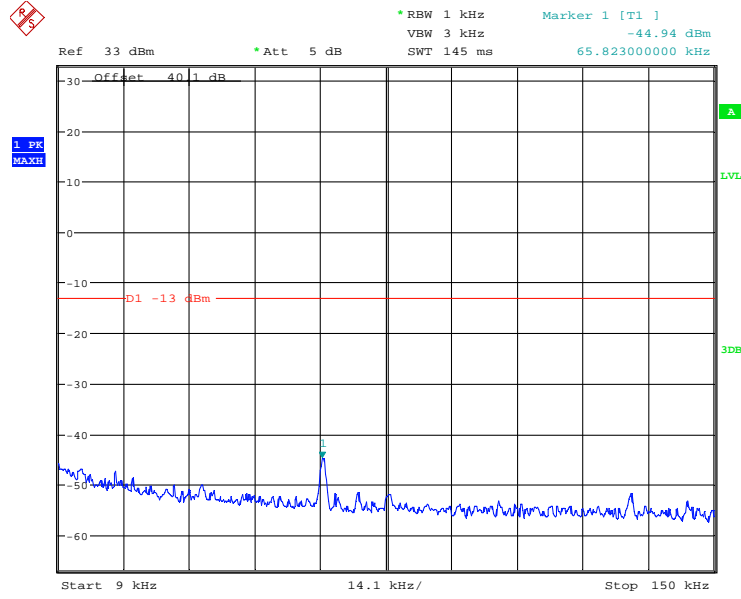

Date: 12.OCT.2016 13:17:44

Low channel bottom 5MHz band 150kHz -30MHz

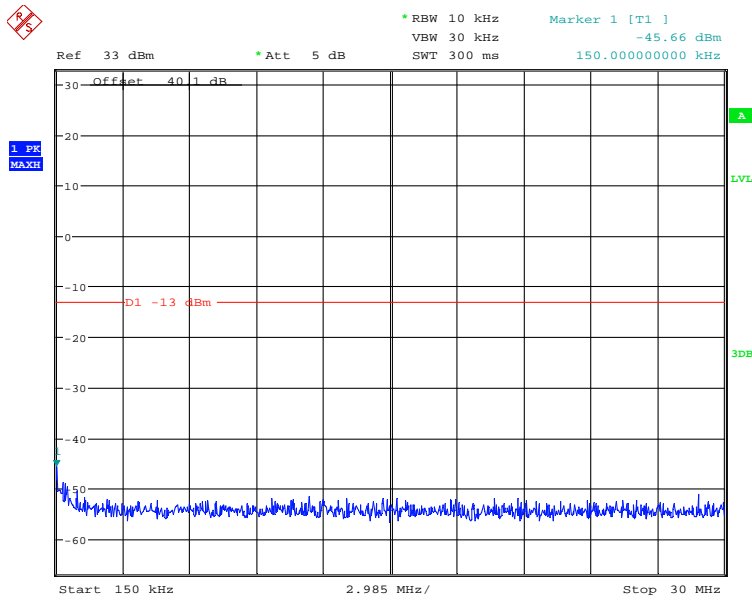

Date: 12.OCT.2016 13:22:06

Mid channel Mid 5MHz band 9-150kHz

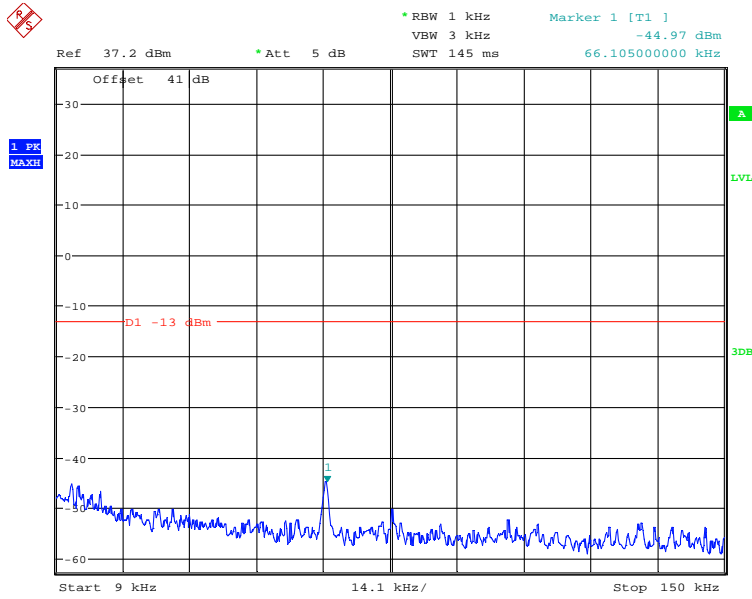

Date: 18.OCT.2016 14:31:38

Mid channel Mid 5MHz band 150kHz-30MHz

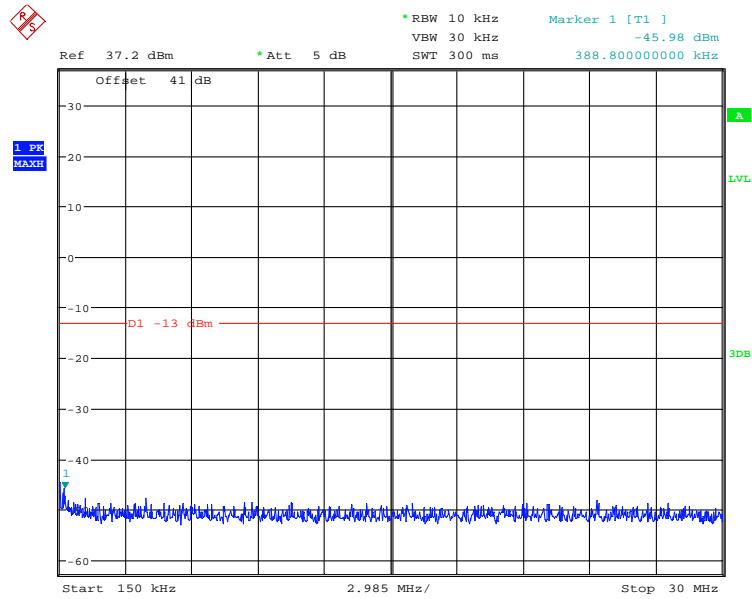

Date: 18.OCT.2016 14:32:55

Hi channel Top 5MHz band 9-150kHz

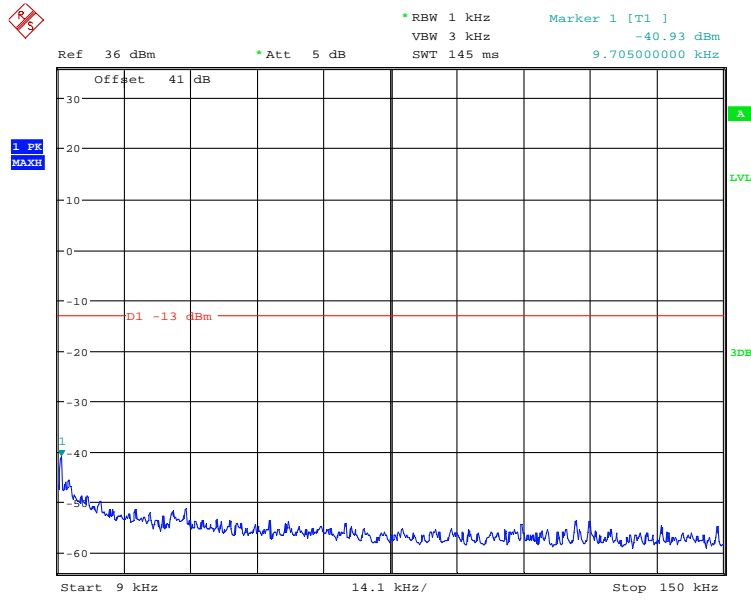

Date: 31.OCT.2016 16:07:21

Hi channel Top 5MHz band 150kHz-30MHz

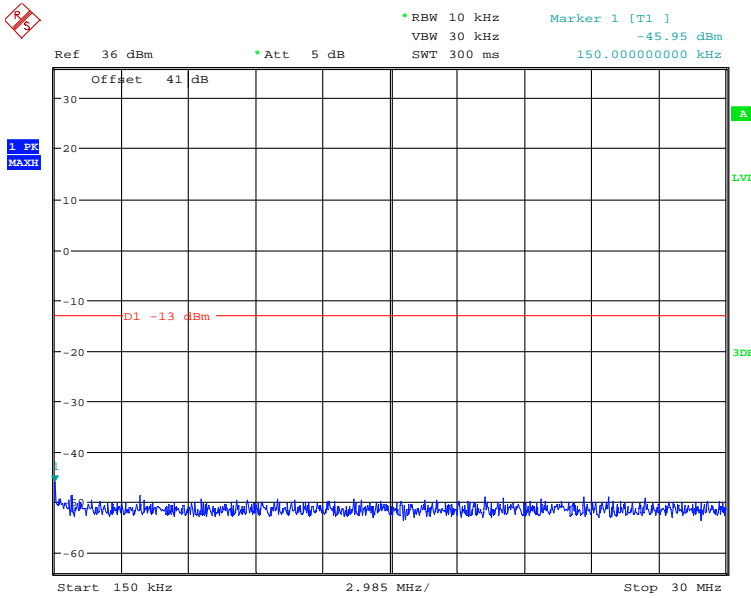

Date: 31.OCT.2016 16:07:55

Hi channel Top 5MHz band 30MHz-1GHz

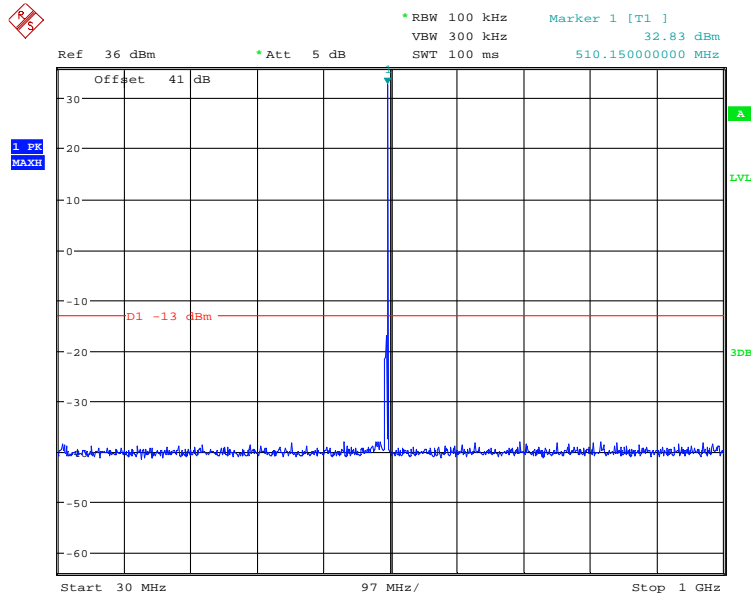

Date: 31.OCT.2016 16:06:38

Hi channel Top 5MHz band 1GHz-6GHz

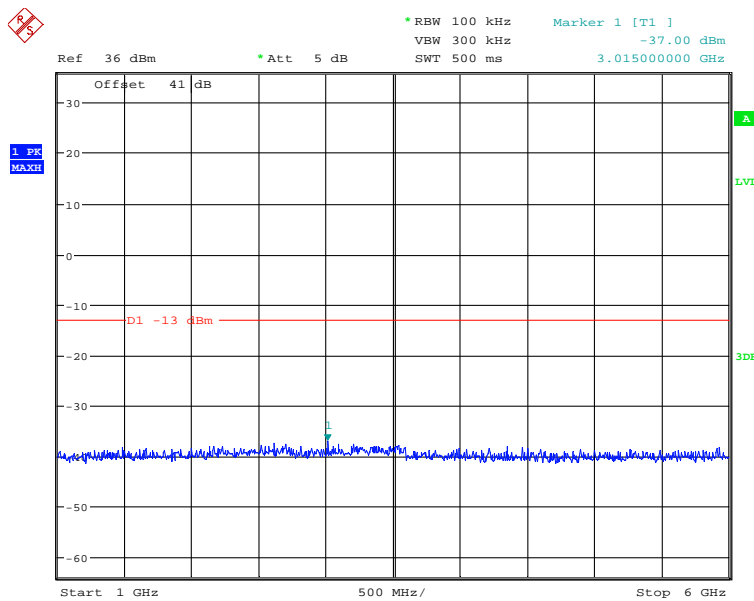

Date: 31.OCT.2016 16:08:56

16 Intermodulation products

16.1 Definition

Spurious intermodulation products result from intermodulation between: – the oscillations at the carrier, characteristic, or harmonic frequencies of an emission, or the oscillations resulting from the generation of the carrier or characteristic frequency; and – oscillations of the same nature, of one or several other emissions, originating from the same transmitting system or from other transmitters or transmitting systems.

16.2 Test Parameters

Test Location:	Element Skelmersdale
Test Chamber:	Radio chamber
Test Standard and Clause:	KDB 935210 D05 v01r01, clause 4.5
Source Tones:	$f_0 \pm 12.5$ kHz, $f_0 \pm 6.25$ kHz, $f_0 \pm 3.125$ kHz
Source Level:	1.35 dBm (AGC threshold); 4.35 dBm (3dB above)
Deviations From Standard:	None
Bandwidth:	RBW 300 Hz; VBW 3xRBW
Span:	100 kHz
Measurement Detector	rms.

Environmental Conditions (Normal Environment)

Temperature: 24°C	+15 °C to +35 °C (as declared)
Humidity: 27%RH	20%RH to 75%RH (as declared)
Supply: 110 V ac	

16.3 Test Limits

The retransmitted signals continue to meet the unwanted emissions limits of §90.210 applicable to the corresponding received signals (assuming that these received signals meet the applicable unwanted emissions limits by a reasonable margin).

16.4 Test Method

With the EUT setup as per section 9 of this report and connected as per Figure viii, two tones were input to the EUT. The combined level at the EUT input was set by the attenuator to just below the EUT AGC threshold level and the intermodulation products were measured on the spectrum analyser. The measurement was repeated with the input attenuator decreased by 3dB.

Figure viii Test Setup

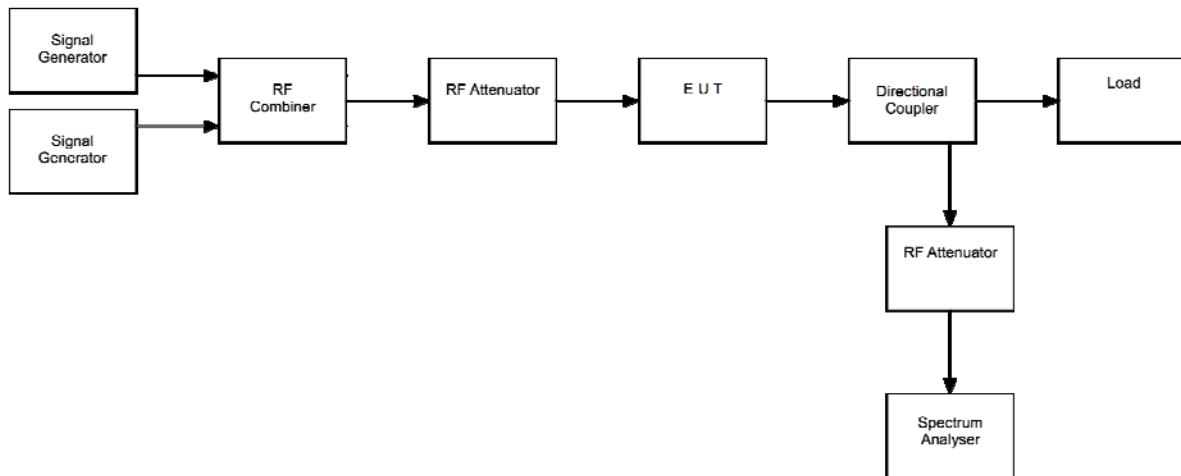

16.5 Test Equipment

Equipment Description	Manufacturer	Equipment Type	Element No	Last Cal Calibration	Calibration Period	Due For Calibration
Spectrum Analyser	R&S	FSU26	U405	02/06/2016	12	02/06/2017
Spectrum Analyser	R&S	FSU46	U281	07/06/2016	12	07/06/2017
Signal Generator	R&S	SMBV100A	REF916	21/03/2016	12	21/03/2017
Signal Generator	Agilent	E4438C	REF844	13/01/2016	24	13/01/2018

16.6 Test Results

Intermodulation @ AGC threshold 25kHz						
Centre Frequency (MHz)	Tone 1 (MHz)	Tone 2 (MHz)	Frequency of Intermodulation Product (MHz)	Highest Intermodulation Product Level (dBm)	Limit (dBm)	Result
491.75482	491.74232	491.76732	491.53747	-17.90	-13	PASS
500.00000	499.98750	500.01250	499.96220	-19.57	-13	PASS
505.65000	505.63750	505.66250	505.68750	-27.65	-13	PASS

Intermodulation @ 3dB above AGC threshold 25kHz						
Centre Frequency (MHz)	Tone 1 (MHz)	Tone 2 (MHz)	Frequency of Intermodulation Product (MHz)	Highest Intermodulation Product Level (dBm)	Limit (dBm)	Result
491.75482	491.74232	491.76732	491.53747	-15.54	-13	PASS
500.00000	499.9875	500.0125	499.96220	-18.37	-13	PASS
505.65000	505.63750	505.66250	505.61250	-19.41	-13	PASS

Intermodulation @ AGC threshold 12.5kHz						
Centre Frequency (MHz)	Tone 1 (MHz)	Tone 2 (MHz)	Frequency of Intermodulation Product (MHz)	Highest Intermodulation Product Level (dBm)	Limit (dBm)	Result
491.75482	491.74857	491.76107	491.55607	-22.40	-13	PASS
500.00000	499.99375	500.00625	499.98100	-19.53	-13	PASS
505.65000	505.64375	505.65625	505.66880	-27.01	-13	PASS

Intermodulation @ 3dB above AGC threshold 12.5kHz						
Centre Frequency (MHz)	Tone 1 (MHz)	Tone 2 (MHz)	Frequency of Intermodulation Product (MHz)	Highest Intermodulation Product Level (dBm)	Limit (dBm)	Result
491.75482	491.74857	491.76107	491.55607	-18.34	-13	PASS
500.00000	499.99375	500.00625	499.98100	-18.14	-13	PASS
505.65000	505.64375	505.65625	505.63120	-19.29	-13	PASS

Intermodulation @ AGC threshold 6.25kHz						
Centre Frequency (MHz)	Tone 1 (MHz)	Tone 2 (MHz)	Frequency of Intermodulation Product (MHz)	Highest Intermodulation Product Level (dBm)	Limit (dBm)	Result
491.75482	491.751695	491.757945	491.56560	-16.37	-13	PASS
500.00000	499.996875	500.003125	499.99040	-19.38	-13	PASS
505.65000	505.646875	505.653125	505.65940	-23.60	-13	PASS

Intermodulation @ 3dB above AGC threshold 6.25kHz						
Centre Frequency (MHz)	Tone 1 (MHz)	Tone 2 (MHz)	Frequency of Intermodulation Product (MHz)	Highest Intermodulation Product Level (dBm)	Limit (dBm)	Result
491.75482	491.751695	491.757945	491.56560	-15.57	-13	PASS
500.00000	499.996875	500.003125	499.99040	-18.75	-13	PASS
505.65000	505.646875	505.653125	505.64060	-19.55	-13	PASS

Bottom 5MHz band/ 25kHz AGC

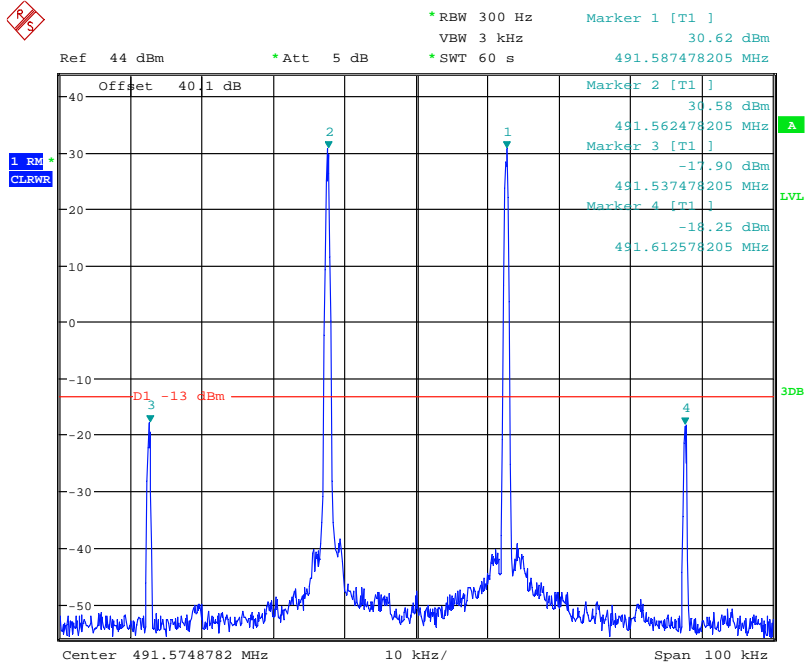

Date: 11.OCT.2016 17:24:57

Bottom 5MHz band/ 25kHz AGC+3dB

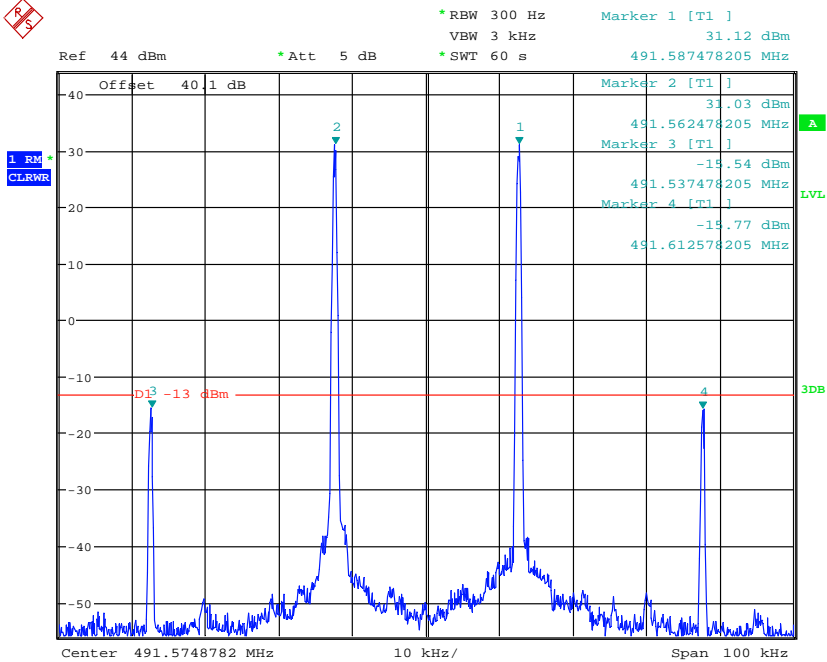

Date: 11.OCT.2016 17:27:57

Bottom 5MHz band/ 12.5kHz AGC

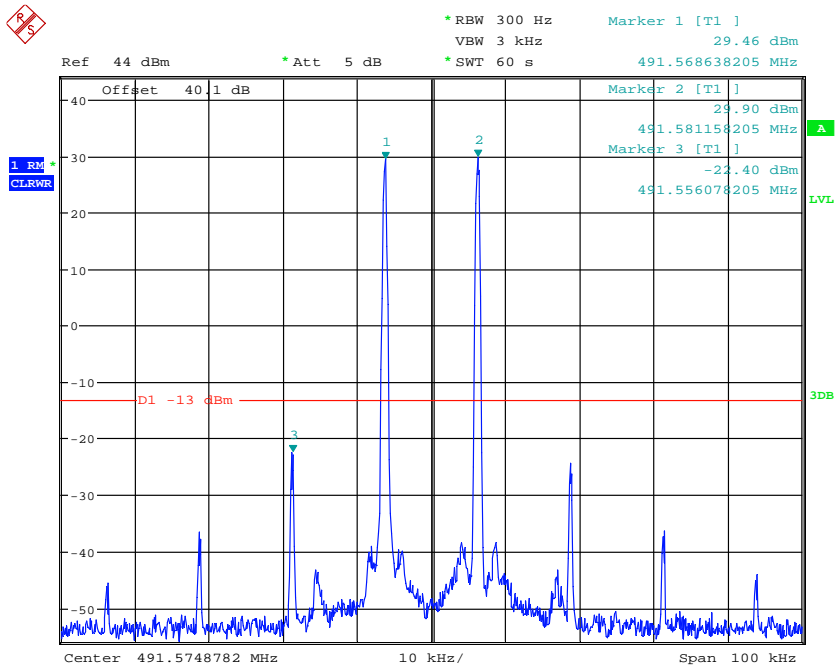

Date: 12.OCT.2016 12:23:50

Bottom 5MHz band/ 12.5kHz AGC+3dB

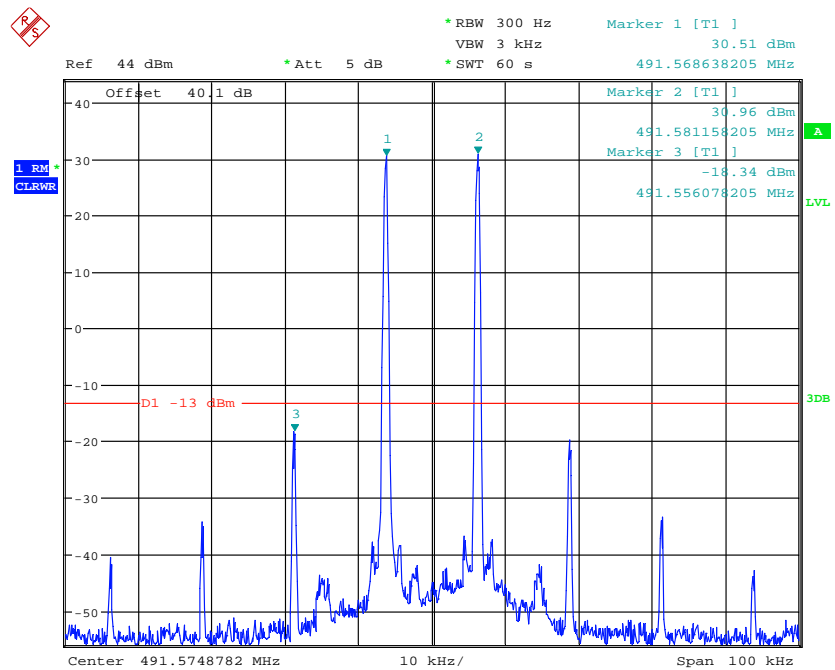

Date: 12.OCT.2016 12:25:33

Bottom 5MHz band/ 6.25kHz AGC

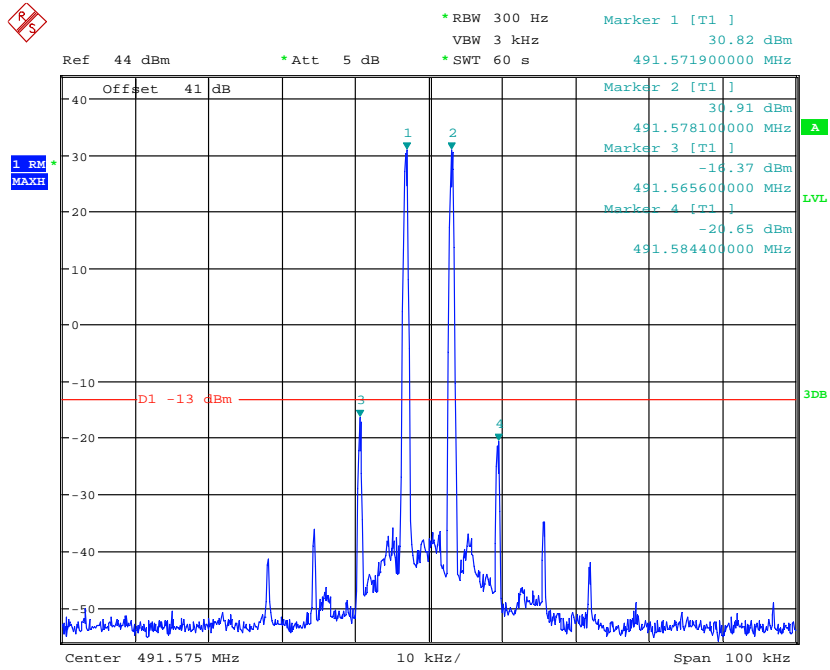

Date: 17.OCT.2016 10:10:05

Bottom 5MHz band/ 6.25kHz AGC+3dB

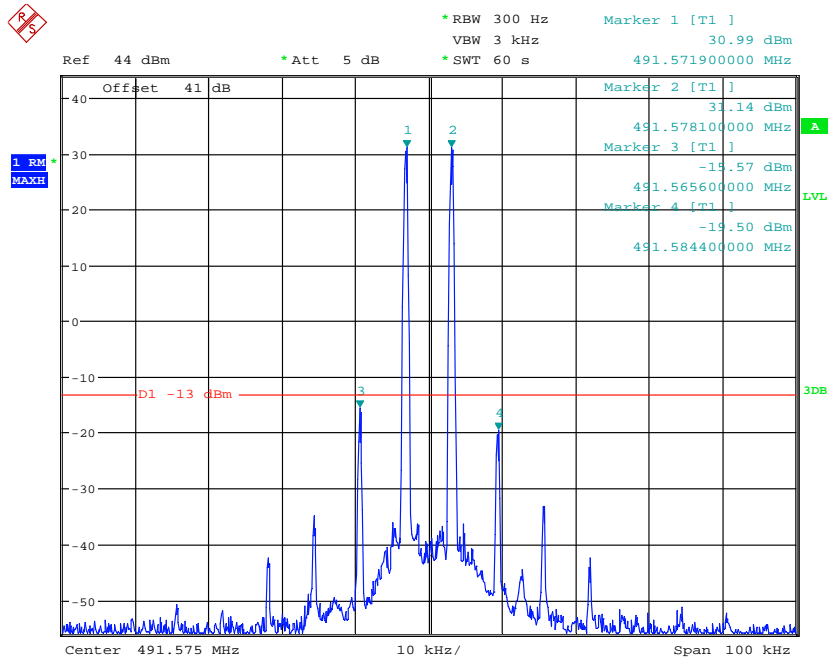

Date: 17.OCT.2016 10:11:40

Mid 5MHz band/ 25kHz AGC

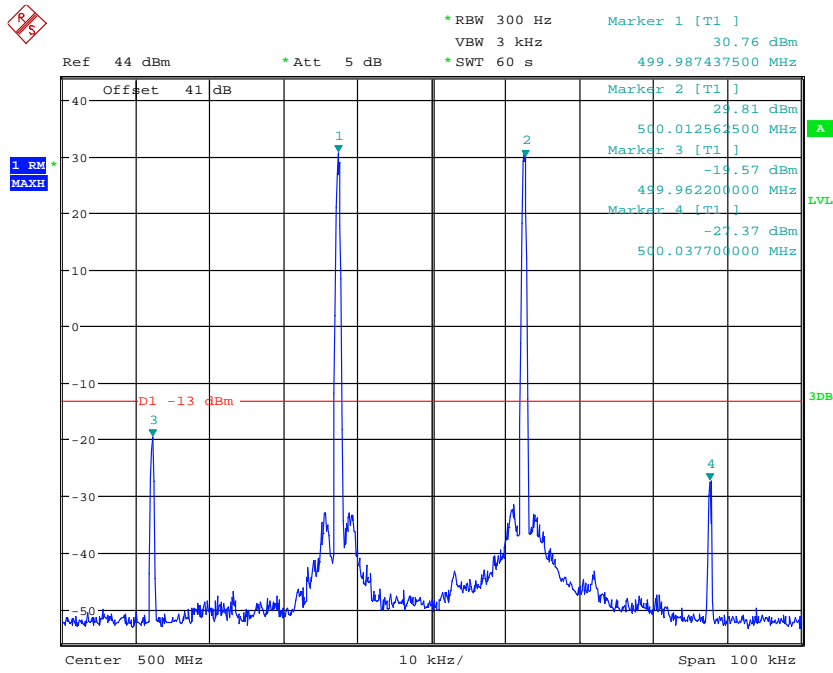

Date: 19.OCT.2016 09:58:56

Mid 5MHz band/ 25kHz AGC+3dB

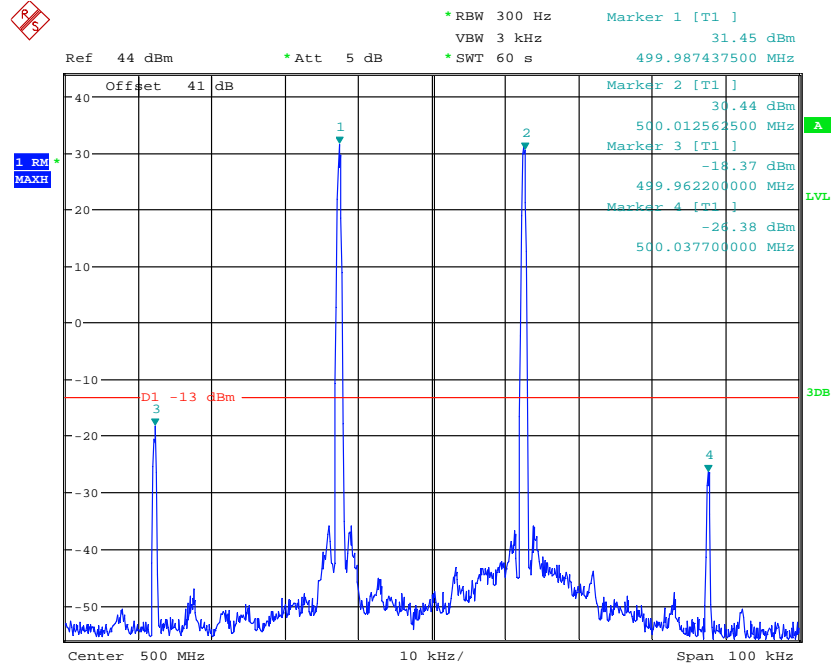

Date: 19.OCT.2016 10:00:42

Mid 5MHz band/ 12.5kHz AGC

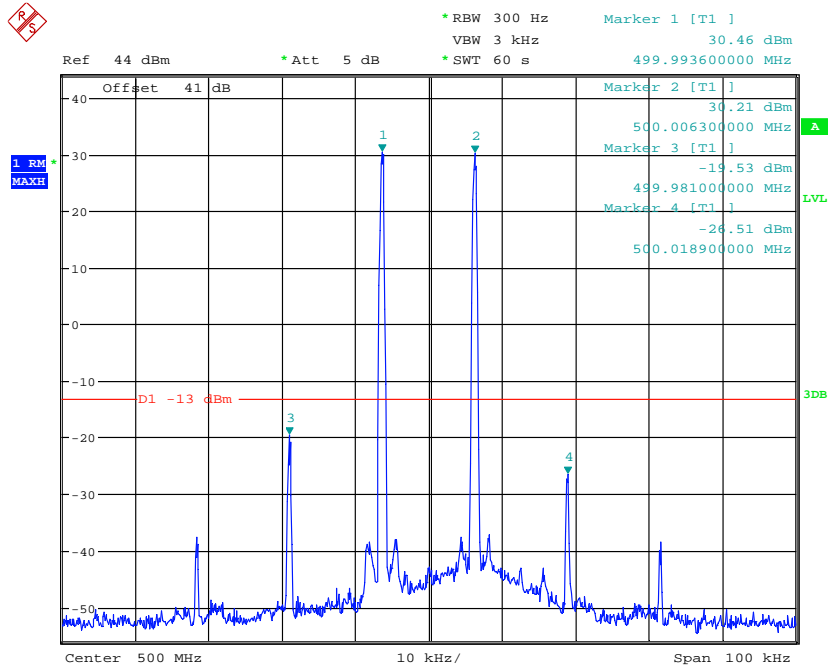

Date: 19.OCT.2016 10:05:12

Mid 5MHz band/ 12.5kHz AGC+3dB

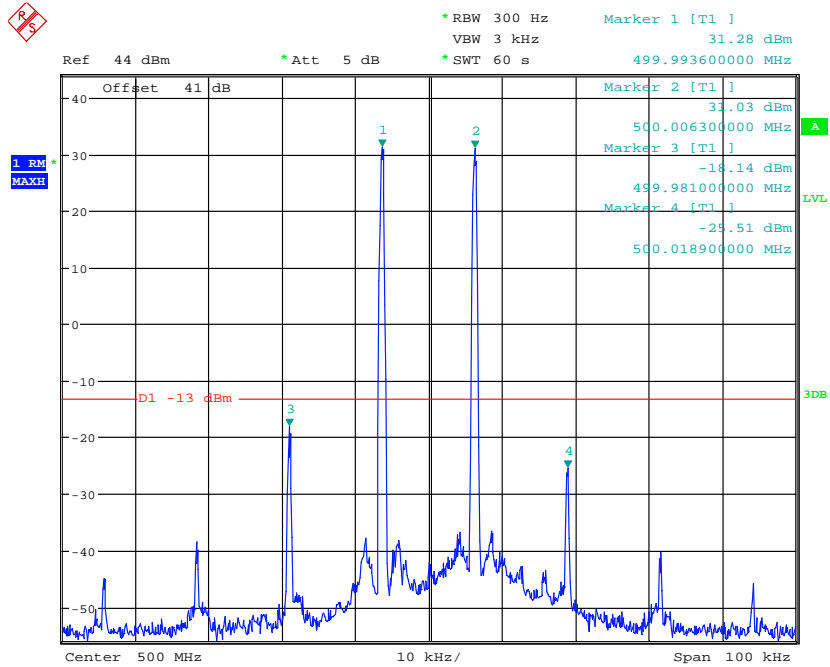

Date: 19.OCT.2016 10:07:45

Mid 5MHz band/ 6.25kHz AGC

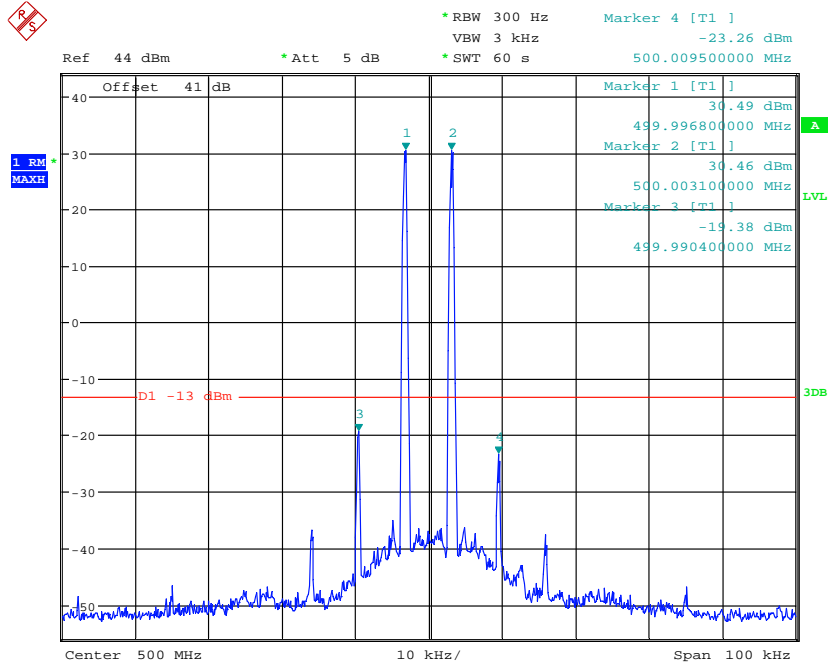

Date: 19.OCT.2016 10:24:23

Mid 5MHz band/ 6.25kHz AGC+3dB

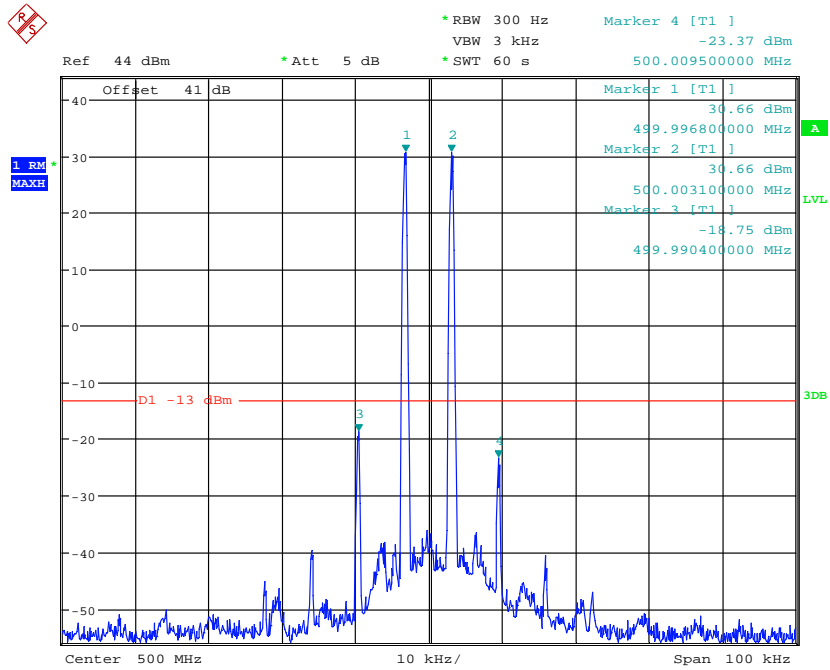

Date: 19.OCT.2016 10:26:08

Top 5MHz band/ 25kHz AGC

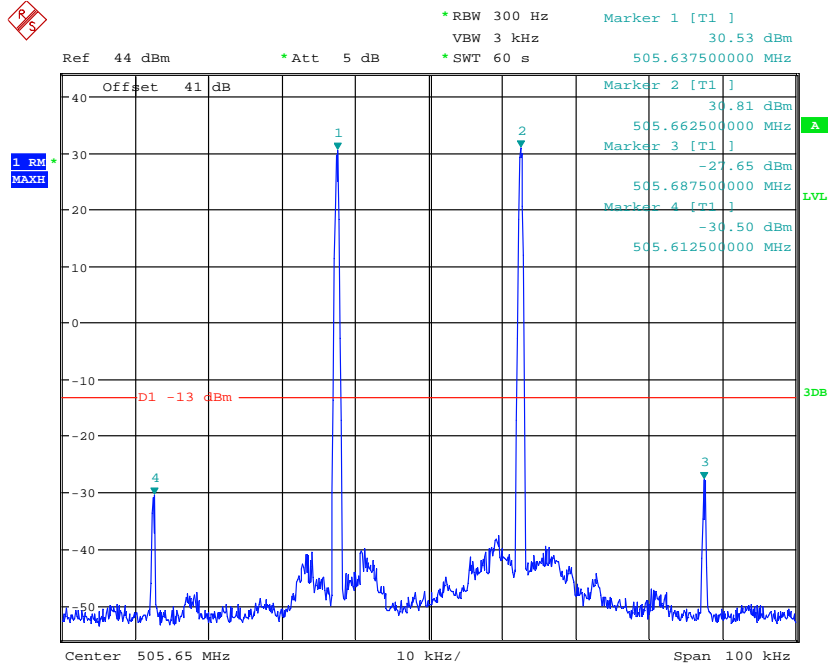

Date: 2.NOV.2016 09:41:03

Top 5MHz band/ 25kHz AGC+3dB

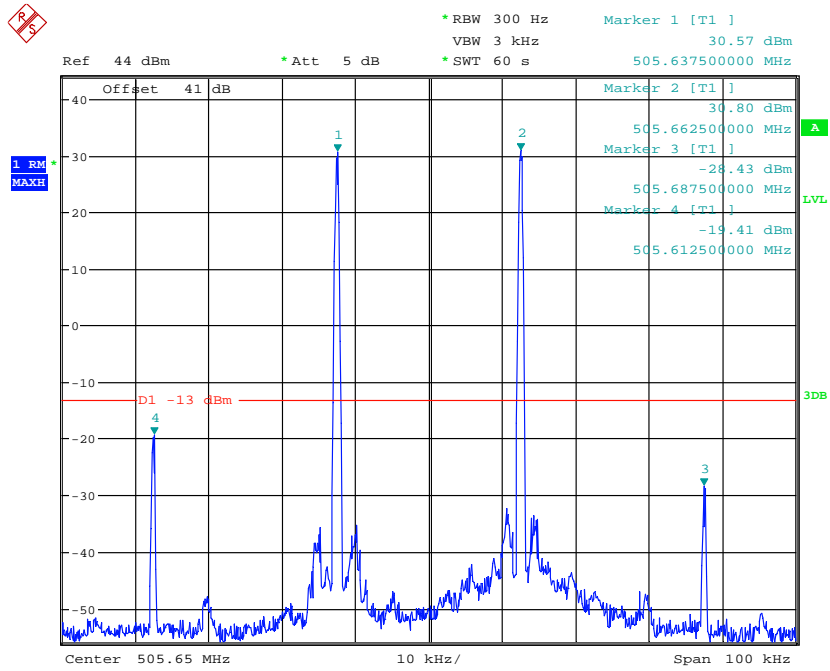

Date: 2.NOV.2016 09:42:31

Top 5MHz band/ 12.5kHz AGC

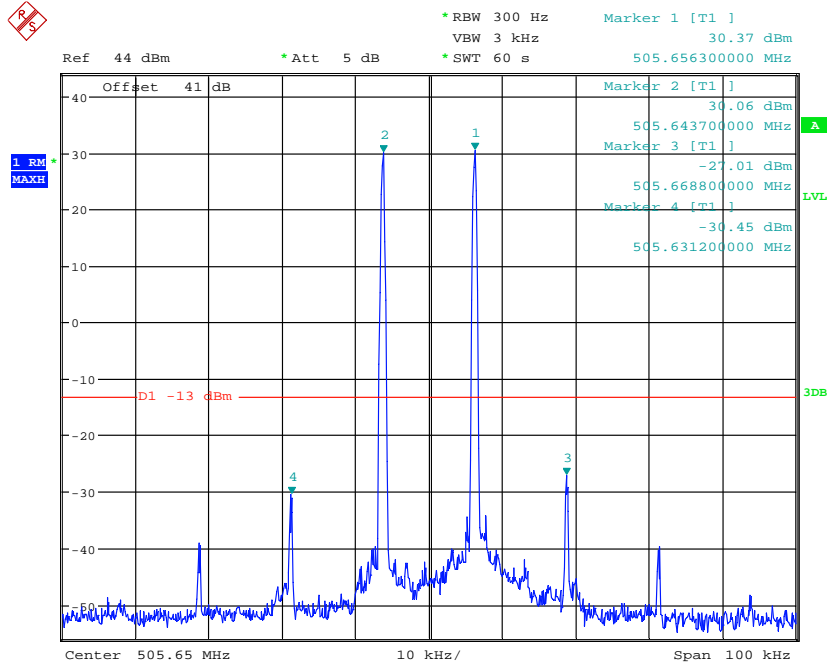

Date: 2.NOV.2016 09:45:38

Top 5MHz band/ 12.5kHz AGC+3dB

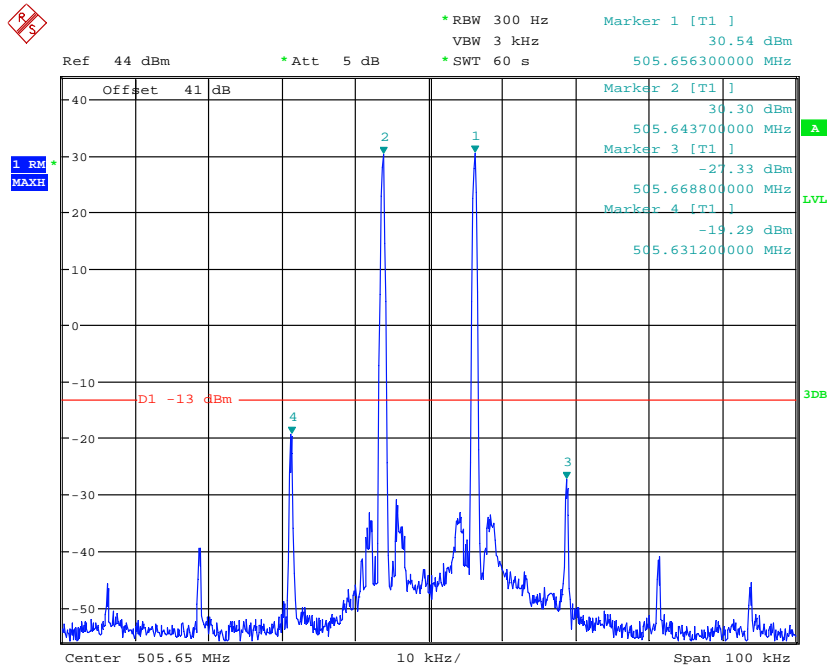

Date: 2.NOV.2016 09:46:59

Top 5MHz band/ 6.25kHz AGC

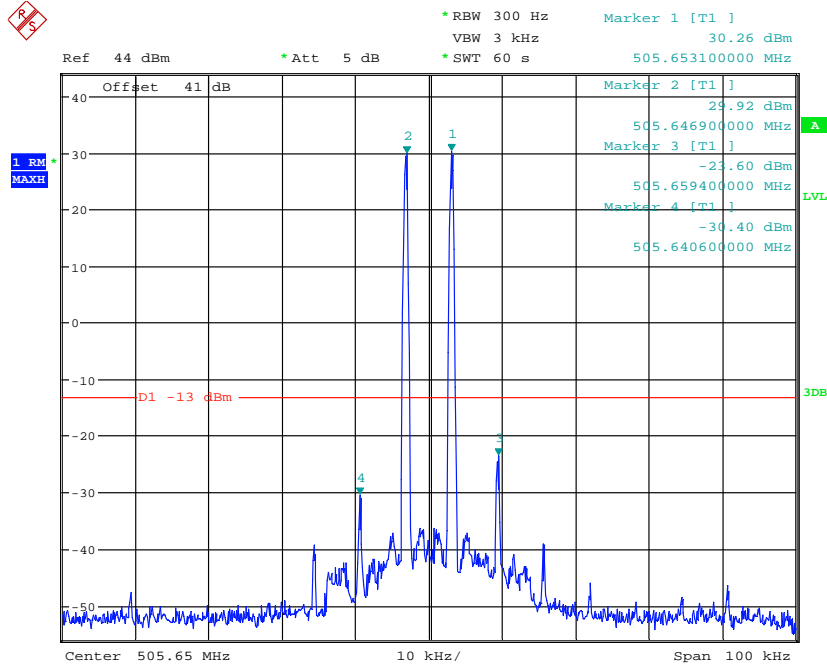

Date: 2.NOV.2016 09:50:28

Top 5MHz band/ 6.25kHz AGC+3dB

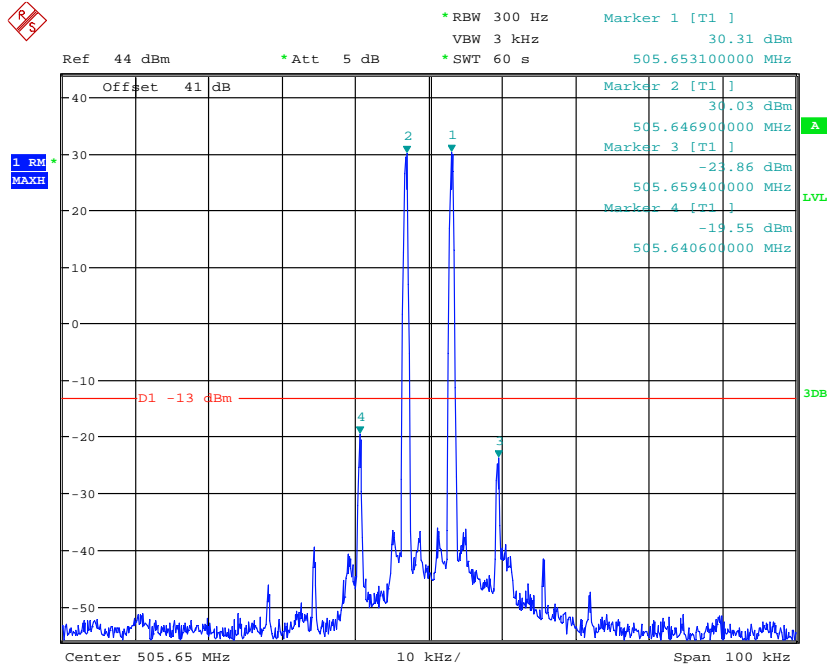

Date: 2.NOV.2016 09:51:54

16.1 Client Supplied Details of Antenna Installation

1.1.1 Antenna Installation

Installation of an antenna must comply with the FCC RF exposure requirements. The antenna used for this transmitter must be mounted on permanent structures.

The FCC regulations mandate that the ERP of type B signal boosters should not exceed 5W, this is equivalent to 8.2W EIRP.

Therefore the max antenna gain allowed for this type of signal booster should be limited to the values given by equation 1 (below) for the service antenna.

Equation (1) - Max SERVICE antenna gain

Max SERVICE antenna gain (dBi) = $39.1 - (37\text{dBm} - \# \text{ of antennas in dB} - \text{cable losses in dB})$.

For example:

No. of Antennas	Cable Losses	Max Allowed Antenna Gain
4	3	$39.1 - (37-6-3) = 11.1\text{dBi}$
1	3	$39.1 - (37-0-3) = 5.1\text{dBi}$
10	3	$39.1 - (37-10-3) = 15.1\text{dBi}$

1.1.2 Compliance with FCC deployment rule regarding the radiation of noise and intermodulation product

Good engineering practice must be used in regard to the signal booster's radiation of intermodulation products and noise. Thus, the gain of the signal booster should be set so that the ERP of the output of intermodulation products from the signal booster should not exceed the level of -30 dBm in 10 kHz measurement bandwidth and noise from the signal booster should not exceed the level of -43 dBm in 10 kHz measurement bandwidth.

In the event that the intermodulation or noise level measured exceeds the aforementioned values, the signal booster gain should be decreased accordingly.

In general, the ERP of noise on a spectrum more than 1 MHz outside of the pass band should not exceed -70 dBm in a 10 kHz measurement bandwidth.

The BSF-3604 61-103001 Repeater has a noise level of -64 dBm in 10 kHz measurement at 1 MHz spectrum outside the passband of the signal booster, worst case intermodulation products at around -15 dBm in a 10 kHz bandwidth and an in-band noise level at around -37 dBm in a 10 kHz bandwidth. Therefore, the noise or intermodulation product at the antenna input port should be calculated based on equation (2).

Equation (2) - Input Noise or intermodulation product to service antenna

Input Noise to service antenna:

$-XX \text{ dBm} + \text{Service Antenna gain} - \text{Antenna splitter losses in dB} - \text{cable loss in dB}$

Example: Intermodulation product

Signal booster connected to 10 service antennas with a 100m long ½ inch cable. Losses of such a cable with the connectors = ~ 12dB

Assuming 10 service antennas: antenna splitter losses = 11 dB

17 Field strength of spurious radiation

17.1 Definitions

Spurious emissions that may be radiated directly from the cabinet, control circuits, power leads, or intermediate circuit elements under normal conditions of installation and operation.

17.2 Test Parameters

Test Location:	Element Skelmersdale
Test Chamber:	Chamber 3
Test Standard and Clause:	TIA 603-D, clause 2.2.12
EUT Operating Frequencies Tested:	Low / Mid / High MHz
Source Modulations:	CW,
Source Level:	1.35 dBm (maximum input rating / AGC threshold)
Deviations From Standard:	None
Frequency Range Examined:	30 MHz – 6 GHz (10 x highest passband)
Measurement BW:	30 MHz to 1 GHz: 120 kHz Above 1 GHz: 1 MHz
Measurement Detector:	Up to 1 GHz: quasi-peak Above 1 GHz: Peak

Environmental Conditions (Normal Environment)

Temperature: 23 °C	+15 °C to +35 °C (as declared)
Humidity: 32 %RH	20%RH to 75%RH (as declared)
Supply: 110Vac	

17.3 Test Limits

Spurious emissions from a signal booster must not exceed -13 dBm within any 100 kHz measurement bandwidth.

17.4 Test Method

With the EUT setup as per section 9 of this report and connected as per Figure ix and with the EUT's antenna replaced by a non-radiating load, the emissions from the EUT were measured on a spectrum analyzer / EMI receiver, and the measurement antenna height scanned (below 1GHz, from 1 to 4 m; above 1GHz as necessary) in order to maximise emissions.

The measurements were performed with EUT set at its maximum gain. All modulation schemes, data rates and power settings were used to observe the worst-case configuration at each frequency.

The EUT was substituted with a known generator and antenna and for the same level achieved at the analyser, the effective radiated power was recorded.

Figure ix Test Setup

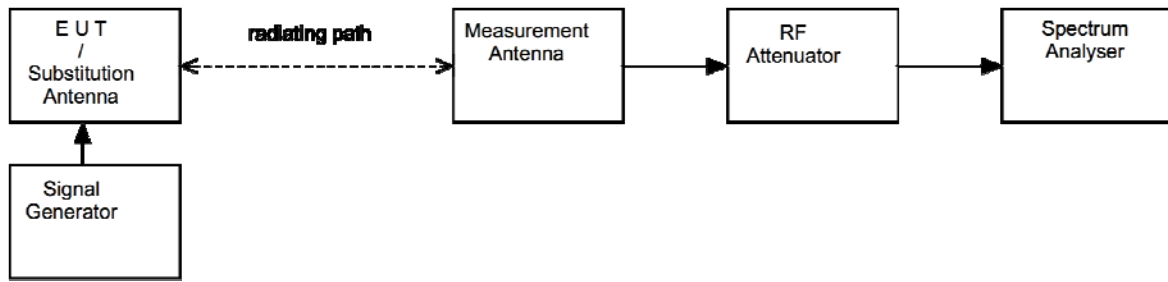

Test Setup Photograph(s)

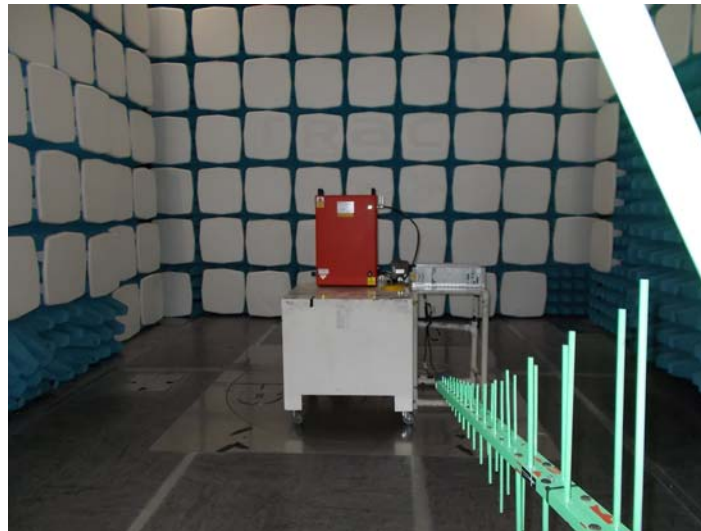

17.5 Test Equipment

Equipment Description	Manufacturer	Equipment Type	Element No	Last Cal Calibration	Calibration Period	Due For Calibration
Bilog	Chase	CBL6112B	U093	17/06/2015	24	17/06/2017
Receiver	R&S	ESVS10	L352	14/07/2016	12	14/07/2017
1-18GHz Horn	EMCO	3115	L139	25/09/2015	24	25/09/2017
Spectrum Analyser	R&S	FSU46	U281	07/06/2016	12	07/06/2017
Pre Amp	Agilent	8449B	L572	16/02/2016	12	16/02/2017
Signal Generator	R&S	SMBV100A	REF916	21/03/2016	12	21/03/2017

17.6 Test Results

Low channel Bottom 5MHz band 30MHz – 1GHz

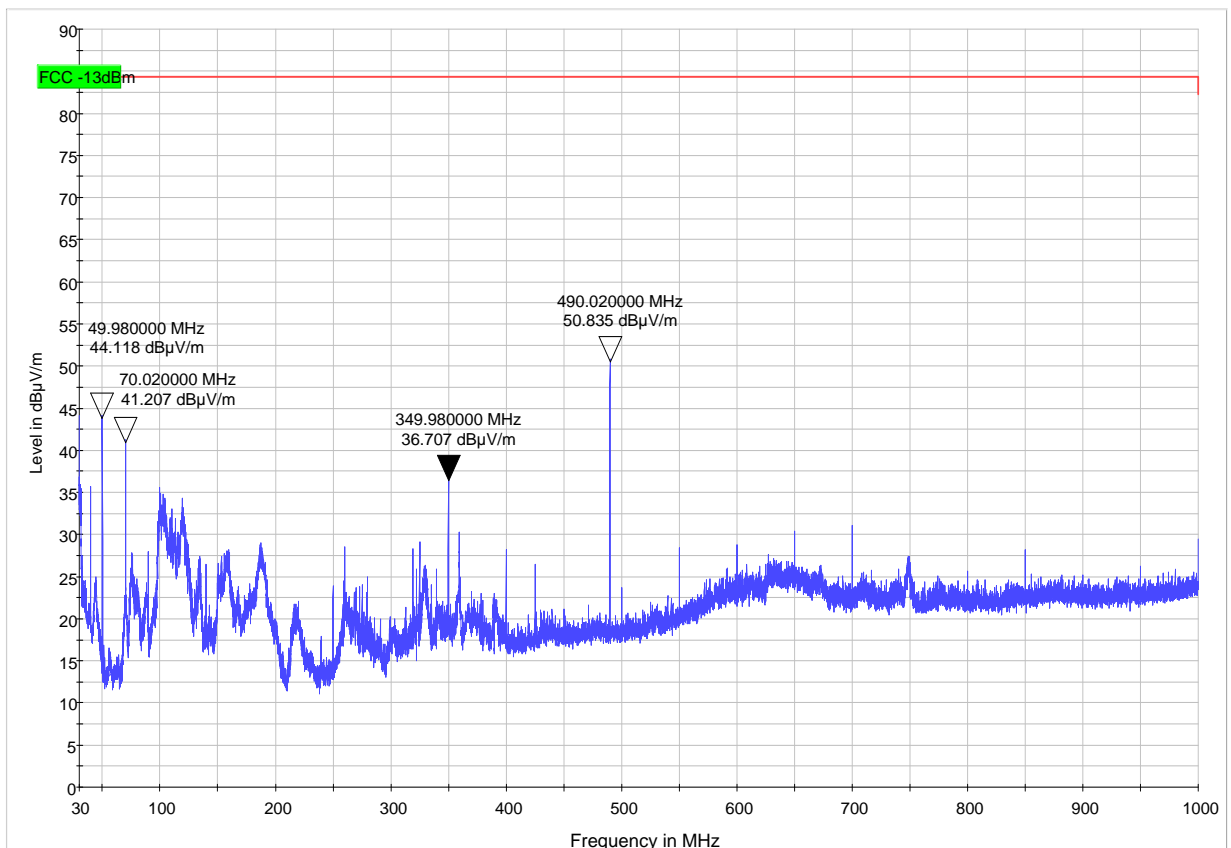

Low channel Bottom 5MHz band 1GHz-6GHz

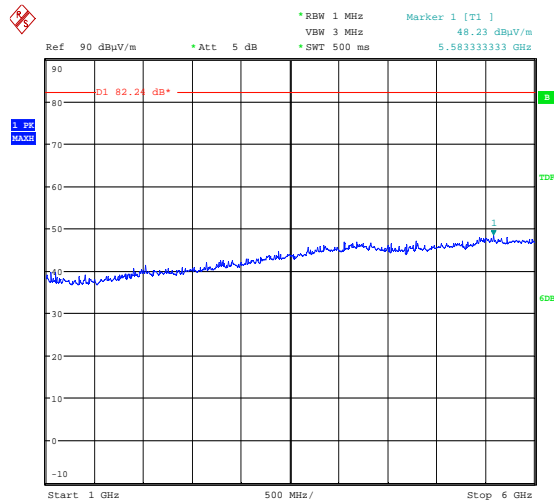

Date: 14.OCT.2016 15:55:32

Mid channel Mid 5MHz band 30MHz – 1GHz

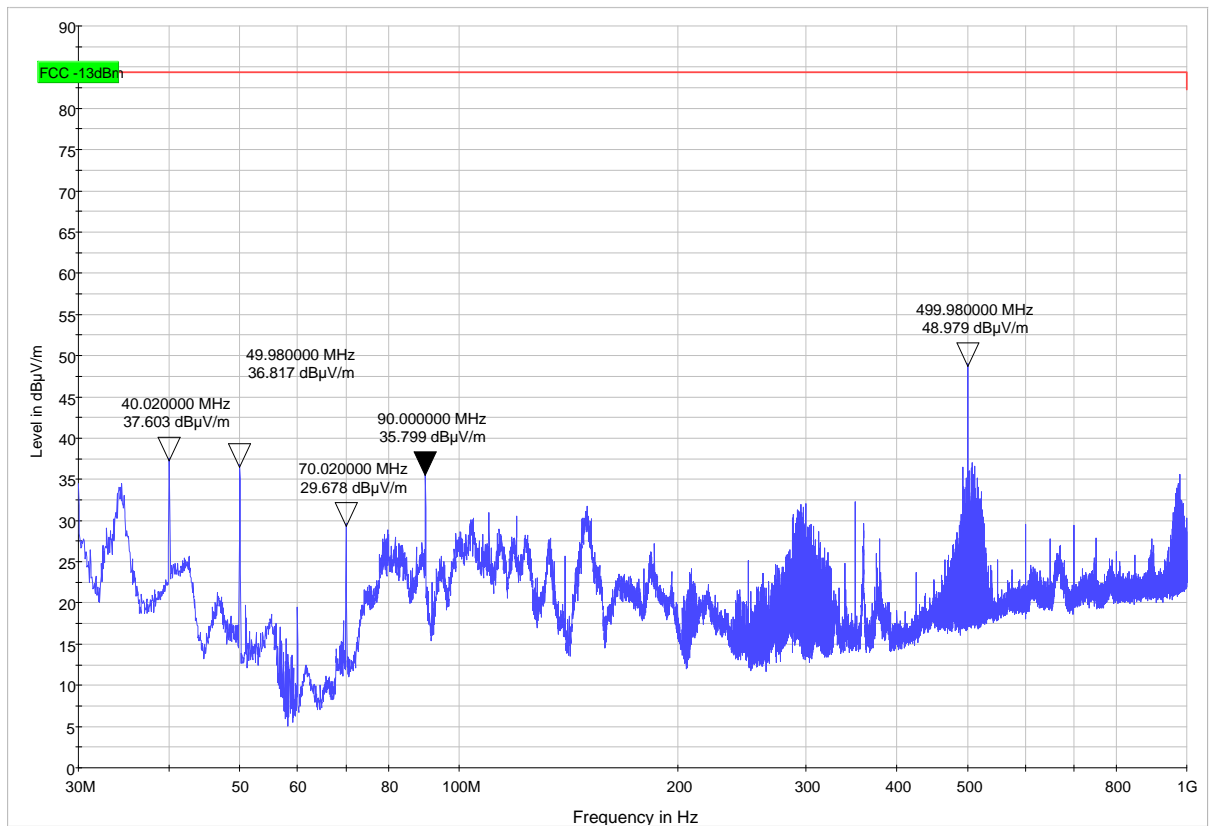

Mid channel Mid 5MHz band 1GHz-6GHz

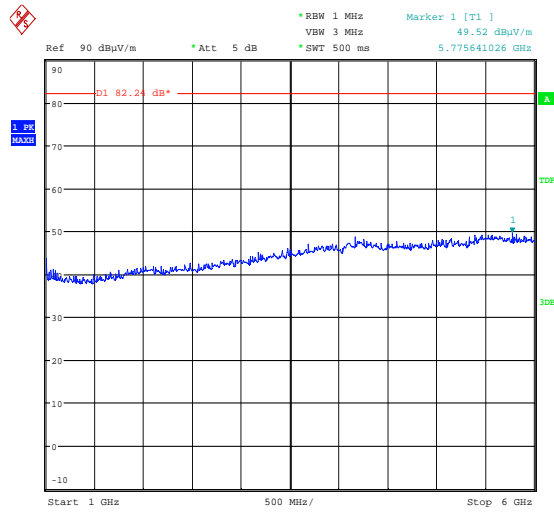

Date: 25.OCT.2016 15:13:50

Top channel top 5MHz band 30MHz – 1GHz

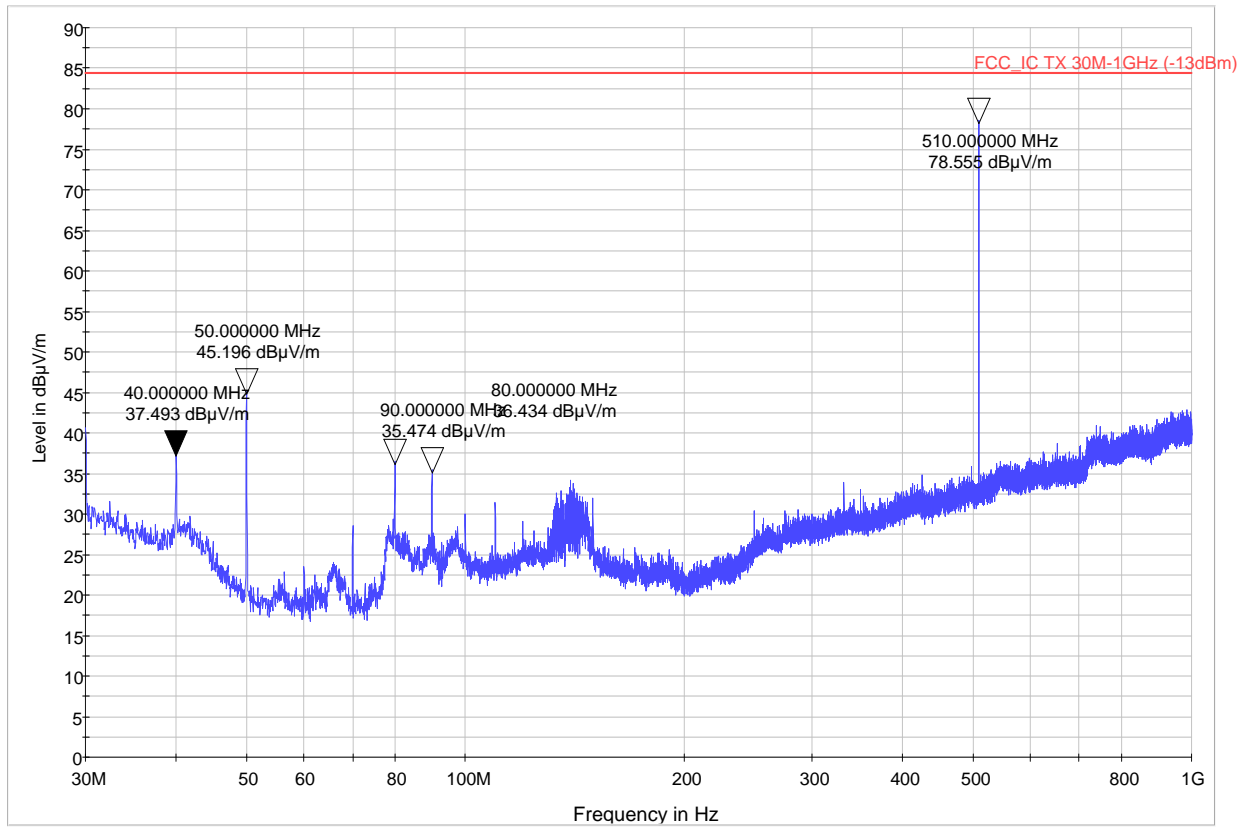

Top channel top 5MHz band 1GHz-6GHz

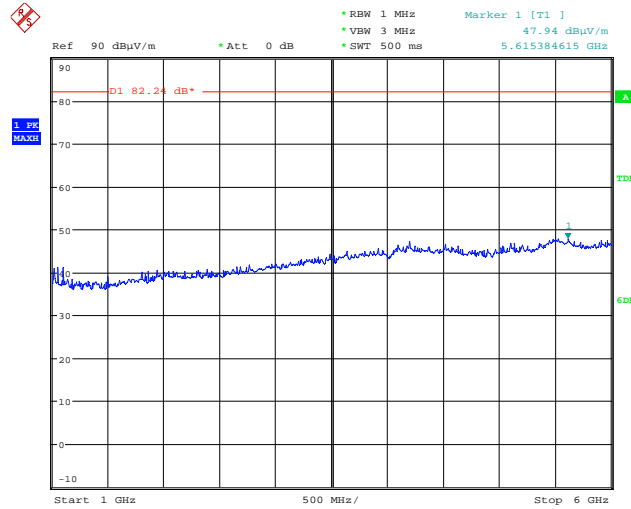

Date: 10.NOV.2016 11:57:45

Low channel Bottom 5MHz band

Low Frequency					
Emission	Frequency (MHz)	Emission level (dBm)	Limit (dBm)	Margin (dB)	Result
1	No Significant emissions within 20dB of the limit				PASS

Mid channel Mid 5MHz band

Mid Frequency					
Emission	Frequency (MHz)	Emission level (dBm)	Limit (dBm)	Margin (dB)	Result
1	No Significant emissions within 20dB of the limit				PASS

Top channel Top 5MHz band

high Frequency					
Emission	Frequency (MHz)	Emission level (dBm)	Limit (dBm)	Margin (dB)	Result
1	No Significant emissions within 20dB of the limit				PASS

18 Frequency stability

18.1 Definition

Frequency stability is a measure of the frequency drift due to temperature and supply voltage variations, with reference to the frequency measured at +20C and rated supply voltage.

18.2 Test Parameters

Test Location:	Element Skelmersdale
Test Chamber:	
Test Standard and Clause:	TIA-603-D-2010, clause 2.2.2
Deviations From Standard:	See client Declaration
Temperature Extreme Environment Test Range:	-30 to +50 C
Voltage Extreme Environment Test Range:	Mains Power = $\pm 15\%$ of Nominal; Battery: nominal and end point;

18.3 Test Limits

18.3.1 47CFR90

The signals are retransmitted on the same channels as received. Minor departures from the exact provider or reference frequencies of the input signals are allowed, *provided that* the retransmitted signals meet the requirements of § 90.213

18.4 Test Method

With the EUT setup as per section 9 of this report and connected as per Figure x, the EUT local oscillator frequency was measured under varying conditions of temperature and supply voltage. Measurements were made once temperature stability was achieved at each temperature.

Figure x Test Setup

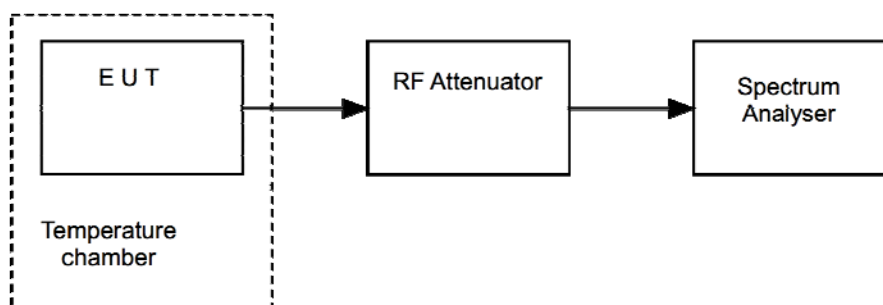

19 Client Declaration



Page 1 of 1

Frequency Stability of Digital Repeaters

Axell Wireless legacy channel selective repeaters take the wanted signal, mixed with a local oscillator down to an IF frequency where the filtering is carried out and then is mixed back to the original frequency with the same local oscillator. If you do the calculations on this process any drift of the local oscillator cancels out and the output always equals the input frequency. Local oscillator drift has the effect of moving the filter centre frequency with respect to the signal so in an extreme case it could result in sideband cutting or even tuning to the next channel but still the output = input.

In a digital repeater exactly the same thing happens with the up/down converter because the conversion process to IF is the same. In the case of a digital repeater the filtering is not based on fixed crystal resonator elements but sampling and calculation based on the same reference oscillator that drives the synthesisers. The effect is the same, the exact filter frequency moves but again the drift cancels and we always have output = input.

There is one more thing to consider, a digital repeater is capable of being programmed for frequency translation but usually it isn't. This would only be done in very rare cases where the licensing administration allows it. Usually it involves a fixed offset (but it need not be), e.g. Output = Input +4MHz. A frequency translating repeater is easy to recognise as in the GUI there will be separate frequency selection boxes for input and output frequency of each channel. In this case the cancellation of reference oscillator error is slightly imperfect and a small residual offset is introduced. The offset is in error by the PPM error of the reference, e.g. the 10MHz reference has an error of +1ppm. A non-frequency shifting repeater with a channel centre frequency of 400MHz moves by 1ppm now becoming centred at 400Hz high, in a frequency shifting repeater (say for argument up by 4MHz) the input channel centred at 400MHz still moves high by 400Hz but now the intended 4MHz shift increases by 4Hz.

AXELL WIRELESS UK
 Asheridge Road
 Chesham, Bucks
 HP5 2QD, UK
 Tel: + 44 (0) 1494 777000
 Fax: + 44 (0) 1494 777002

info@axellwireless.com
 www.axellwireless.com

AXELL WIRELESS SWEDEN
 Box 7139
 174 07 Sundbyberg
 Sweden
 Tel: + 46 (0) 8 475 4700
 Fax: + 46 (0) 8 475 4799

20 Measurement Uncertainty

For the test data recorded the following measurement uncertainty was calculated:

Radio Testing – General Uncertainty Schedule

All statements of uncertainty are expanded standard uncertainty using a coverage factor of 1.96 to give a 95% confidence where no required test level exists.

[1] Adjacent Channel Power

Uncertainty in test result = **1.86dB**

[2] Carrier Power

Uncertainty in test result (Power Meter) = **1.08dB**
 Uncertainty in test result (Spectrum Analyser) = **2.48dB**

[3] Effective Radiated Power

Uncertainty in test result = **4.71dB**

[4] Spurious Emissions

Uncertainty in test result = **4.75dB**

[5] Maximum frequency error

Uncertainty in test result (Frequency Counter) = **0.113ppm**
 Uncertainty in test result (Spectrum Analyser) = **0.265ppm**

[6] Radiated Emissions, field strength OATS 14kHz-18GHz Electric Field

Uncertainty in test result (14kHz – 30MHz) = **4.8dB**,
 Uncertainty in test result (30MHz – 1GHz) = **4.6dB**,
 Uncertainty in test result (1GHz – 18GHz) = **4.7dB**

[7] Frequency deviation

Uncertainty in test result = **3.2%**

[8] Magnetic Field Emissions

Uncertainty in test result = **2.3dB**

[9] Conducted Spurious

Uncertainty in test result – Up to 8.1GHz = **3.31dB**
 Uncertainty in test result – 8.1GHz – 15.3GHz = **4.43dB**
 Uncertainty in test result – 15.3GHz – 21GHz = **5.34dB**
 Uncertainty in test result – Up to 26GHz = **3.14dB**

[10] Channel Bandwidth

Uncertainty in test result = **15.5%**

[11] Amplitude and Time Measurement – Oscilloscope

Uncertainty in overall test level = **2.1dB**,
Uncertainty in time measurement = **0.59%**,
Uncertainty in Amplitude measurement = **0.82%**

[12] Power Line Conduction

Uncertainty in test result = **3.4dB**

[13] Spectrum Mask Measurements

Uncertainty in test result = **2.59% (frequency)**
Uncertainty in test result = **1.32dB (amplitude)**

[14] Adjacent Sub Band Selectivity

Uncertainty in test result = **1.24dB**

[15] Receiver Blocking – Listen Mode, Radiated

Uncertainty in test result = **3.42dB**

[16] Receiver Blocking – Talk Mode, Radiated

Uncertainty in test result = **3.36dB**

[17] Receiver Blocking – Talk Mode, Conducted

Uncertainty in test result = **1.24dB**

[18] Receiver Threshold

Uncertainty in test result = **3.23dB**

[19] Transmission Time Measurement

Uncertainty in test result = **7.98%**