



TEST REPORT
FOR
AXELL WIRELESS
ON
800MHz U/L FO BOOSTER AMPLIFIER
DOCUMENT NO. TTR-005045-W-US-05

TEST REPORT NO: TTR-005045-W-US-5

COPY NO: 1

ISSUE NO: 1

FCC ID: NEO-275001

**REPORT ON THE CERTIFICATION TESTING OF A
AXELL WIRELESS
EXPOSITION METRO LINE
800MHZ U/L FO BOOSTER AMPLIFIER
WITH RESPECT TO
THE FCC RULES CFR 47,
PART 90**

PRIVATE LAND MOBILE REPEATER.

TEST DATE: 20th - 23rd May 2011

APPROVED BY: _____



J CHARTERS
PRODUCT MANAGER

DATE: 6th June 2011

Distribution:

- Copy Nos:
1. Axell Wireless
 2. TRaC Global

THIS DOCUMENT MAY BE REPRODUCED ONLY IN ITS ENTIRETY AND WITHOUT CHANGE

CONTENTS

	PAGE		
CERTIFICATE OF CONFORMITY & COMPLIANCE	4		
APPLICANT'S SUMMARY	5		
EQUIPMENT TEST CONDITIONS	6		
TESTS REQUIRED	6		
TEST RESULTS	7 – 28		
		ANNEX	
PHOTOGRAPHS		A	
PHOTOGRAPH No. 1&2: Test setup			
PHOTOGRAPH No. 3: Equipment overview			
APPLICANT'S SUBMISSION OF DOCUMENTATION LIST		B	
EQUIPMENT CALIBRATION		C	
MEASUREMENT UNCERTAINTY		D	
Notes:			
1. Component failure during test		YES	<input type="checkbox"/>
		NO	<input checked="" type="checkbox"/>
2. If Yes, details of failure:			
3. The facilities used for the testing of the product contain in this report are FCC Listed.			

CERTIFICATE OF CONFORMITY & COMPLIANCE

FCC IDENTITY:	NEO-275001
PURPOSE OF TEST:	Certification
TEST SPECIFICATION:	FCC RULES CFR 47, Part 90
TEST RESULT:	Compliant to Specification
EQUIPMENT UNDER TEST:	800MHz U/L FO BOOSTER AMPLIFIER
EQUIPMENT TYPE:	Private Land Mobile Repeater
MAXIMUM GAIN:	Uplink (800MHz) = 59.34 dB
MAXIMUM INPUT:	Uplink (800MHz) = - 24.90dBm
MAXIMUM OUTPUT CONDUCTED:	Uplink (800MHz) = +34.44dBm
CHANNEL BANDWIDTH:	N/A Wideband amplifier
FREQUENCY GENERATION:	N/A
MODULATION TYPE:	F3E
POWER SOURCE(s):	+110Vac
TEST DATE(s):	20 th – 23 rd May 2011
ORDER No(s):	72741
APPLICANT:	Axell Wireless
ADDRESS:	Aerial House Asheridge Road Chesham Buckinghamshire HP5 1TU
TESTED BY:	D. WINSTANLEY

APPROVED BY:



J CHARTERS
PRODUCT
MANAGER

APPLICANT'S SUMMARY

EQUIPMENT UNDER TEST (EUT): 800MHz U/L FO BOOSTER AMPLIFIER

EQUIPMENT TYPE: Private Land Mobile Repeater

PURPOSE OF TEST: Certification

TEST SPECIFICATION(s): FCC RULES CFR 47, Part 90

TEST RESULT: COMPLIANT Yes
No

APPLICANT'S CATEGORY: MANUFACTURER
IMPORTER
DISTRIBUTOR
TEST HOUSE
AGENT

APPLICANT'S ORDER No(s): 72741

APPLICANT'S CONTACT PERSON(s): Mr Peter Bradfield

E-mail address: peter.bradfield@axellwireless.com

APPLICANT: Axell Wireless

ADDRESS: Aerial House
Asheridge Road
Chesham
Buckinghamshire
HP5 1TU
United Kingdom

TEL: +44 (0)1494 777000

FAX: +44 (0)1494 778456

MANUFACTURER: Axell Wireless

EUT(s) COUNTRY OF ORIGIN: United Kingdom

TEST LABORATORY: TRaC Global

TEST DATE(s): 16th - 18th May 2011

TEST REPORT No: TTR-005045WUS5

EQUIPMENT TEST / EXAMINATIONS REQUIRED

1.	TEST/EXAMINATION	RULE PART	APPLICABILITY	RESULT
	RF Power Output	90.205	Yes	Complies
	Audio Frequency Response	TIA EIA-603.3.2.6	N/A	N/A
	Audio Low-Pass Filter Response	TIA EIA-603.3.2.6	N/A	N/A
	Modulation Limiting	TIA EIA-603.3.2.6	N/A	N/A
	Occupied Bandwidth	90.210	Yes	Complies
	Spurious Emissions at Antenna Terminals	90.210	Yes	Complies
	Field Strength of Spurious Emissions	90.210	Yes	Complies
	Frequency Stability	90.213	N/A(note 1)	N/A
	Transient behaviour	90.214	N/A(note 2)	N/A

Notes:

- 1 The EUT does not contain modulation circuitry, therefore the test was not performed.
 2 The EUT is not a keyed carrier system, therefore the test was not performed.

2. Product class: Uplink Class A Class B
3. Product Use: Private Land Mobile Repeater
4. Emission Designator: F3E
5. Temperatures: Ambient (Tnom) 24°C
6. Supply Voltages: Vnom +110Vac
- Note: Vnom voltages are as stated above unless otherwise shown on the test report page
7. Equipment Category: Single channel
 Two channel
 Multi-channel
8. Channel spacing: Wideband Uplink
9. Test Location TRaC Global Skelmersdale
10. Modifications made during test program No modifications were performed.

System description:

The 800MHz U/L FO BOOSTER AMPLIFIER system consists of an 800MHz uplink wideband amplifier. The uplink is a wideband amplifier and operates over the frequency band 812MHz - 816MHz

COMPLIANCE TESTS

AMPLIFIER GAIN – CONDUCTED – PART 2.1046 –800MHz UPLINK

Ambient temperature = 24°C
 Relative humidity = 50%
 Supply voltage = +110Vac
 Channel number = See test results

Radio Laboratory

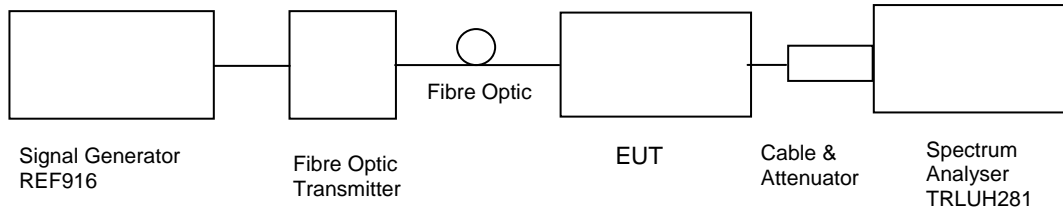

Frequency MHz	Signal Generator input level dBm	Input Cable Loss dB	Output Cable & Attenuator loss dB	Level at Spectrum Analyser dBm	Gain dB	Conducted Output Power dBm	Gain after 10dB input level increase dB
812.000	-25.00	0.10	40.5	-6.49	59.11	34.01	49.10
814.000	-24.80	0.10	40.5	-6.06	59.34	34.44	49.36
816.000	-25.70	0.10	40.5	-7.01	59.29	33.49	49.27

Notes: 1.The signal generator input was increased by 10dBs and the level of the output signal remeasured.

TYPE OF EQUIPMENT	MAKER/ SUPPLIER	MODEL No	SERIAL No	TRL No	ACTUAL EQUIPMENT USED
SPECTRUM ANALYSER	RHODE & SCHWARZ	FSU46	200034	UH281	X
ATTENUATOR	HP	11708A	37341	UH287	X
ATTENUATOR	BIRD	8304-100-N	N/A	222	X
CABLE	TRL	N/A	N/A	UH358	X
CABLE	TRL	N/A	N/A	UH273	X
SIGNAL GENERATOR	RHODE & SCHWARZ	SMBV100	255812	REF916	X

AMPLIFIER INTERMODULATION SPURIOUS EMISSIONS – CONDUCTED – PART 2.1053 –800MHZ UPLINK

Ambient temperature = 22°C
 Relative humidity = 42%
 Supply voltage = +110Vac

Radio Laboratory

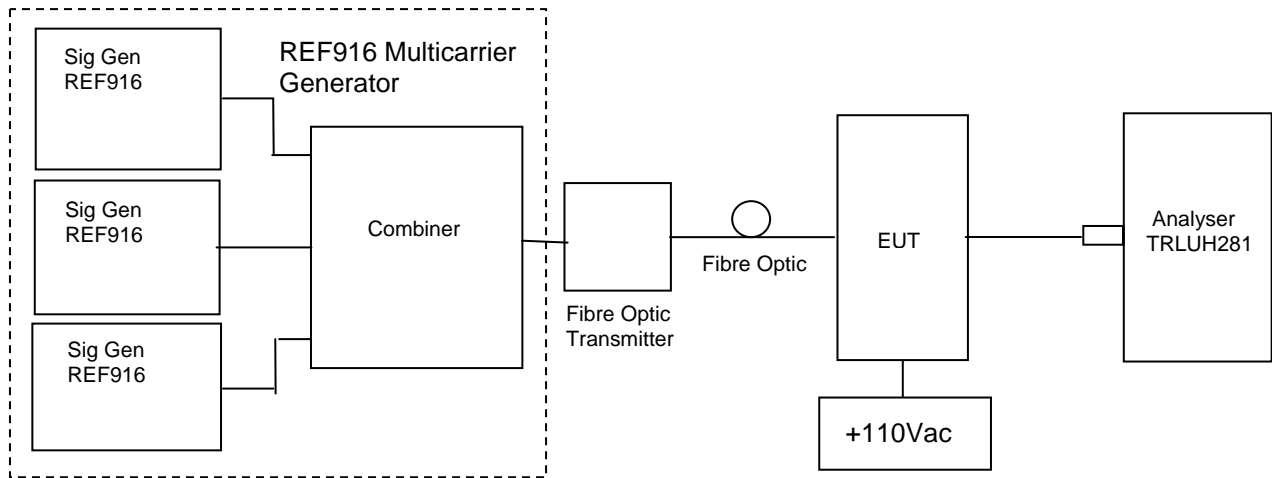

The intermodulation and spurious products were measured with the amplifier operating at maximum gain. A three tone test was conducted using the equipment as above. The input power level was adjusted so the level at point D was 10dB above the maximum input. The cable and attenuator loss between the EUT and the spectrum analyser was 40.5dB.

RF Input Frequency (MHz)			Highest Intermodulation Product Level (dBm)	Limit (dBm)
812.0	813.0	815.0	-14.56dBm @ 814.0 MHz	-13

Sweep data is shown on the next page:

Test equipment used for intermodulation test

TYPE OF EQUIPMENT	MAKER/SUPPLIER	MODEL No	SERIAL No	TRL No	ACTUAL EQUIPMENT USED
SPECTRUM ANALYSER	R&S	FSU46	200034	UH281	X
SIGNAL GENERATOR	RHODE & SCHWARZ	SMBV100	255812	REF916	X
CABLE	TRL	N/A	N/A	UH358	X
CABLE	TRL	N/A	N/A	UH273	X
ATTENUATOR	BIRD	8304-100-N	N/A	222	X
ATTENUATOR	HP	11708A	37341	UH287	X

Intermodulation Close View

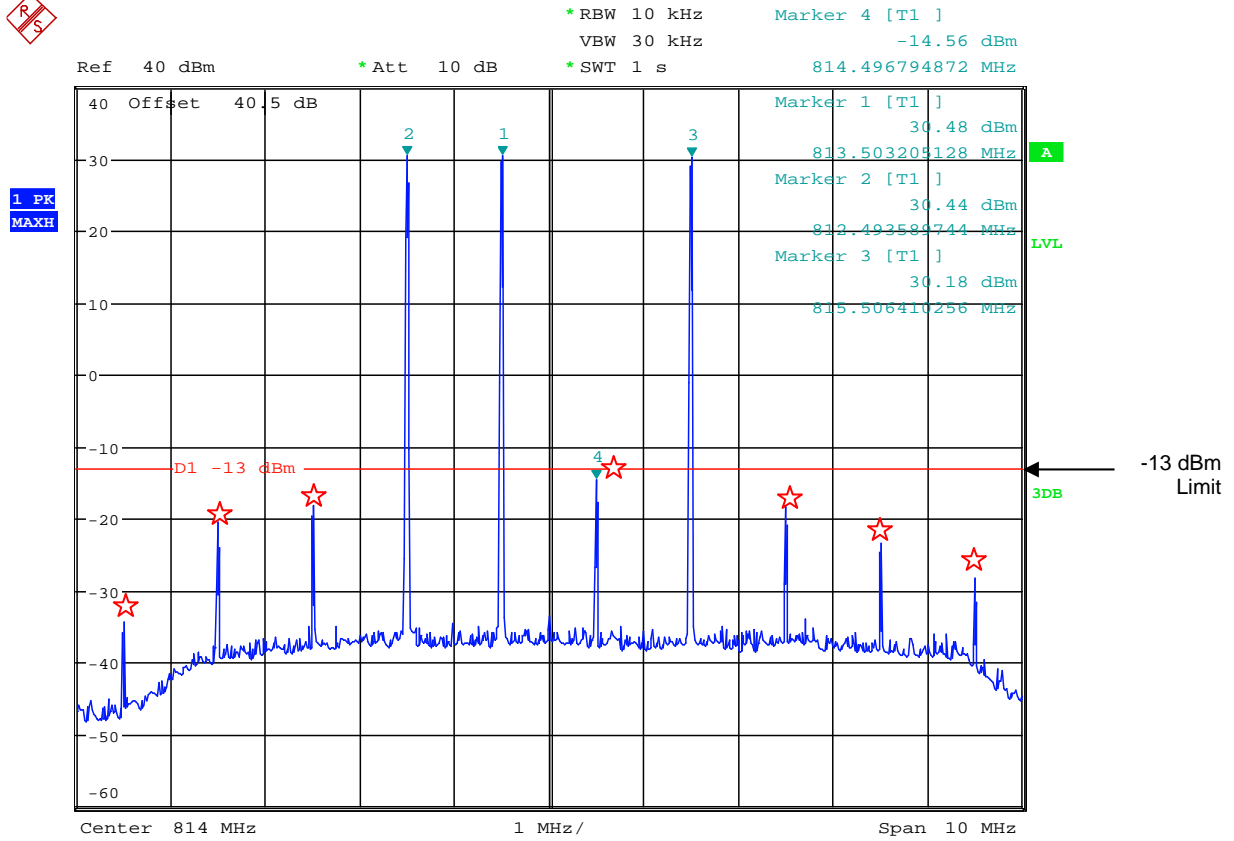

Date: 23.MAY.2011 11:42:30

The above plots show that all products (designated by ☆) are below the spurious limit.

Intermodulation Wide View

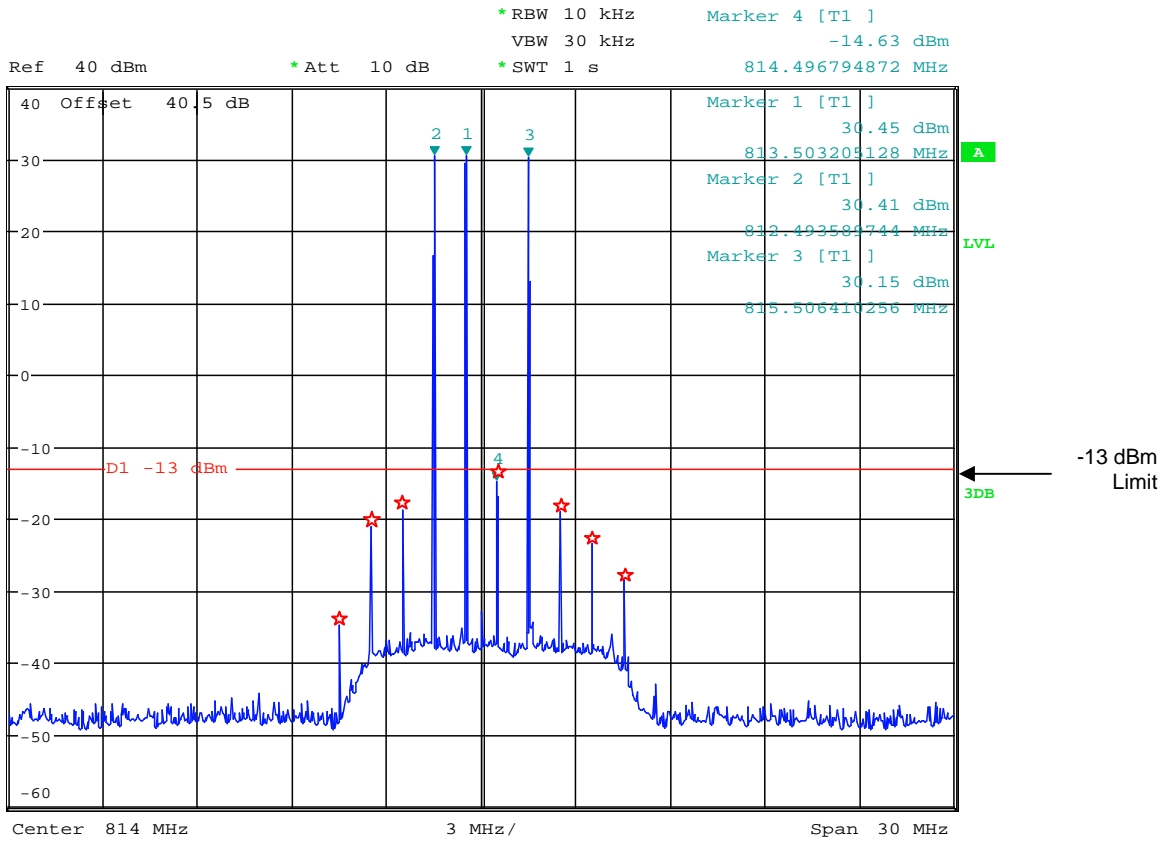

Date: 23.MAY.2011 11:42:41

The above plots show that all products (designated by ☆) are below the spurious limit.

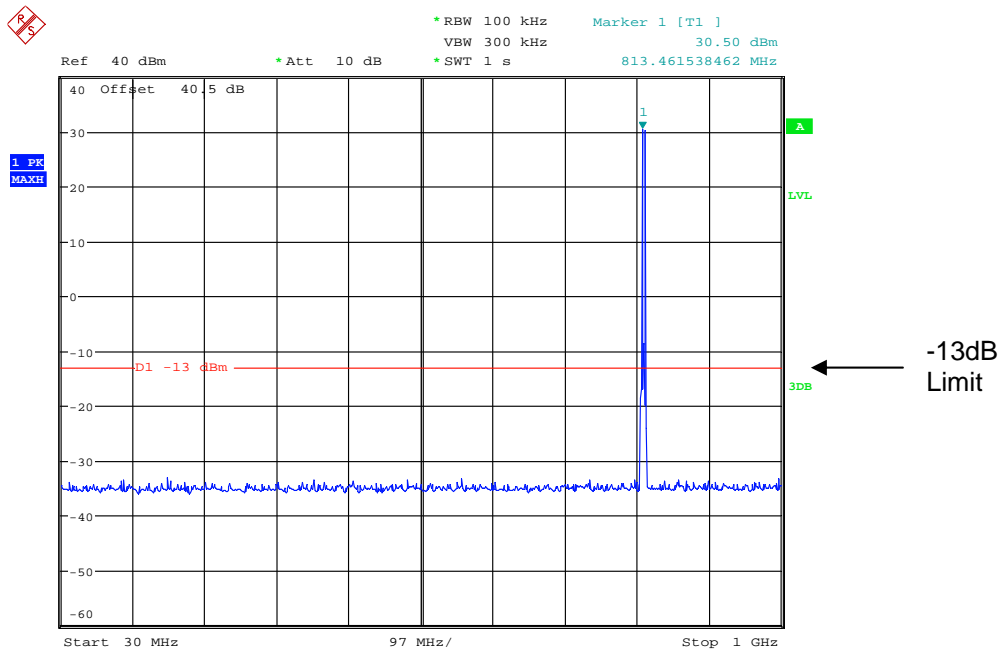

Date: 23.MAY.2011 11:45:09

30MHz – 1GHz

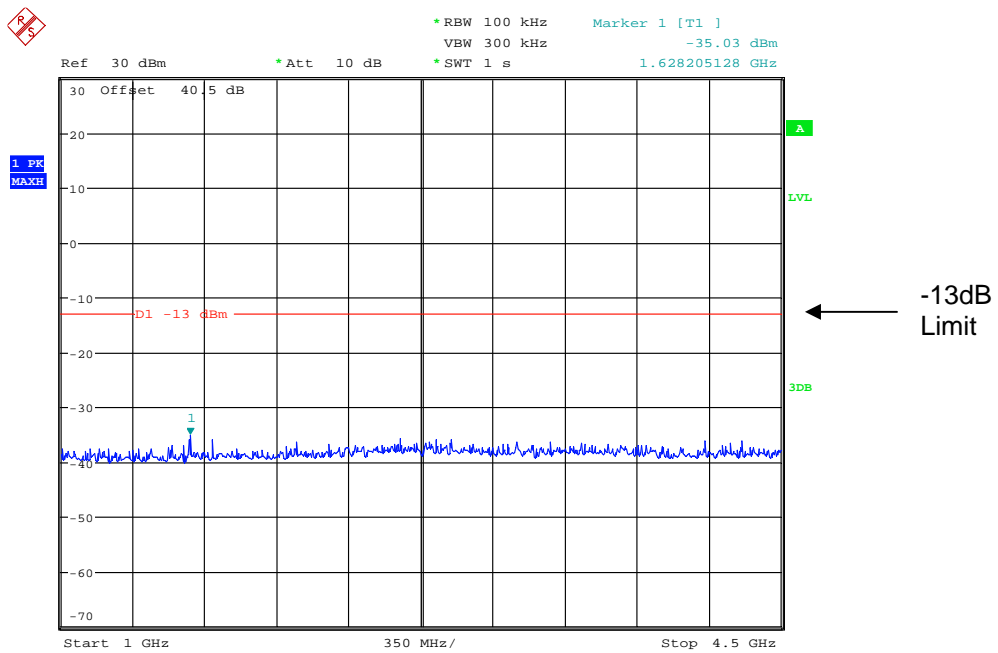

Date: 23.MAY.2011 11:45:32

1GHz – 4.5GHz

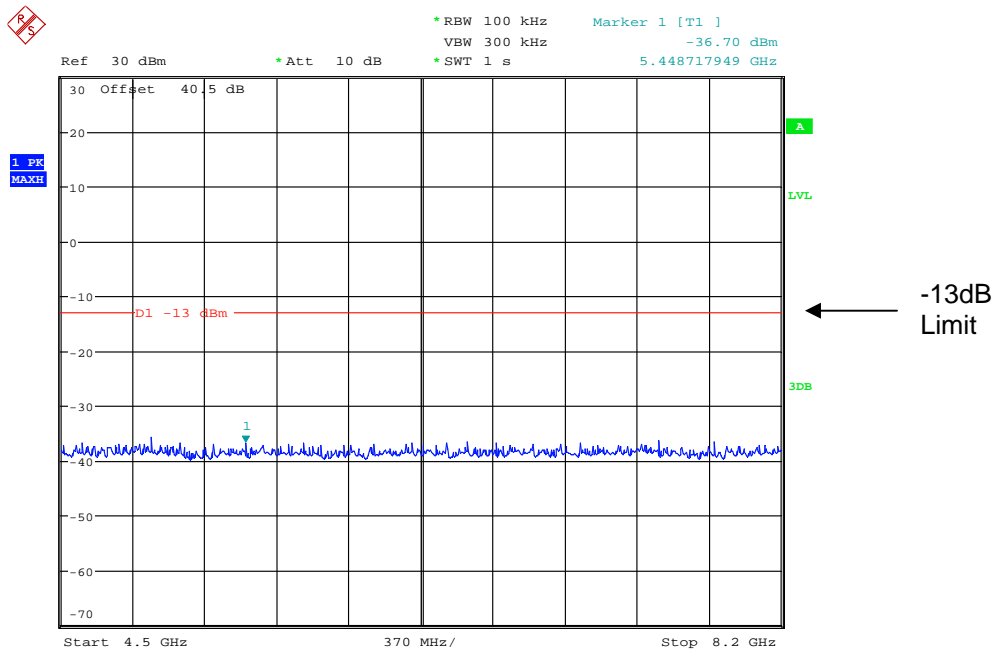

Date: 23.MAY.2011 11:45:59

4.5GHz – 8.2GHz

TRANSMITTER TESTS

AMPLIFIER MODULATED CHANNEL TEST – CONDUCTED – Part 2.1049 – 800MHz UPLINK

Ambient temperature = 24°C
 Relative humidity = 50%
 Supply voltage = +110Vac
 Channel number = See test results

Radio Laboratory

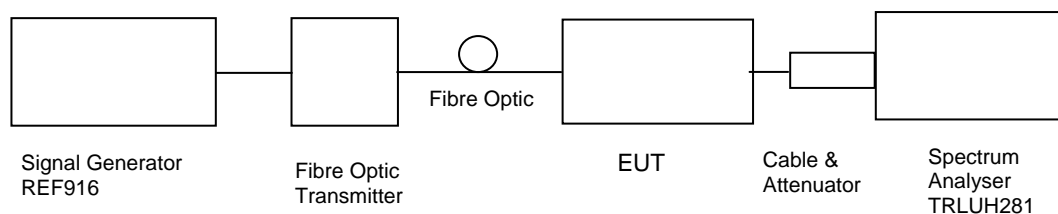

This test was performed to show that the amplifier does not alter the input signal in any way. The input signal was set to the maximum input and modulated with a 2500Hz tone. The plots show the signal measured at the signal generator and the signal measured at the output of the EUT.

Note: The cables and attenuators had the following losses.

1. Cable and attenuator between EUT and spectrum analyser 35.8
2. Cable between signal generator and EUT 0.07dB
3. See Table below for 99% Power Occupied Bandwidth

Frequency Of Operation Channel	Modulation Type
	2.5kHz Deviation FM
812.0MHz	99% Bandwidth =10.128kHz
814.0MHz	99% Bandwidth =10.128kHz
816.0MHz	99% Bandwidth =10.128kHz

TYPE OF EQUIPMENT	MAKER/ SUPPLIER	MODEL No	SERIAL No	TRL No	ACTUAL EQUIPMENT USED
SPECTRUM ANALYSER	RHODE & SCHWARZ	FSU46	200034	UH281	X
ATTENUATOR	HP	11708A	37341	UH287	X
ATTENUATOR	BIRD	8304-100-N	N/A	222	X
CABLE	TRL	N/A	N/A	UH358	X
CABLE	TRL	N/A	N/A	UH273	X
SIGNAL GENERATOR	RHODE & SCHWARZ	SMBV100	255812	REF916	X

812.0 MHz Signal Generator and EUT deviation set to 2.5 kHz FM

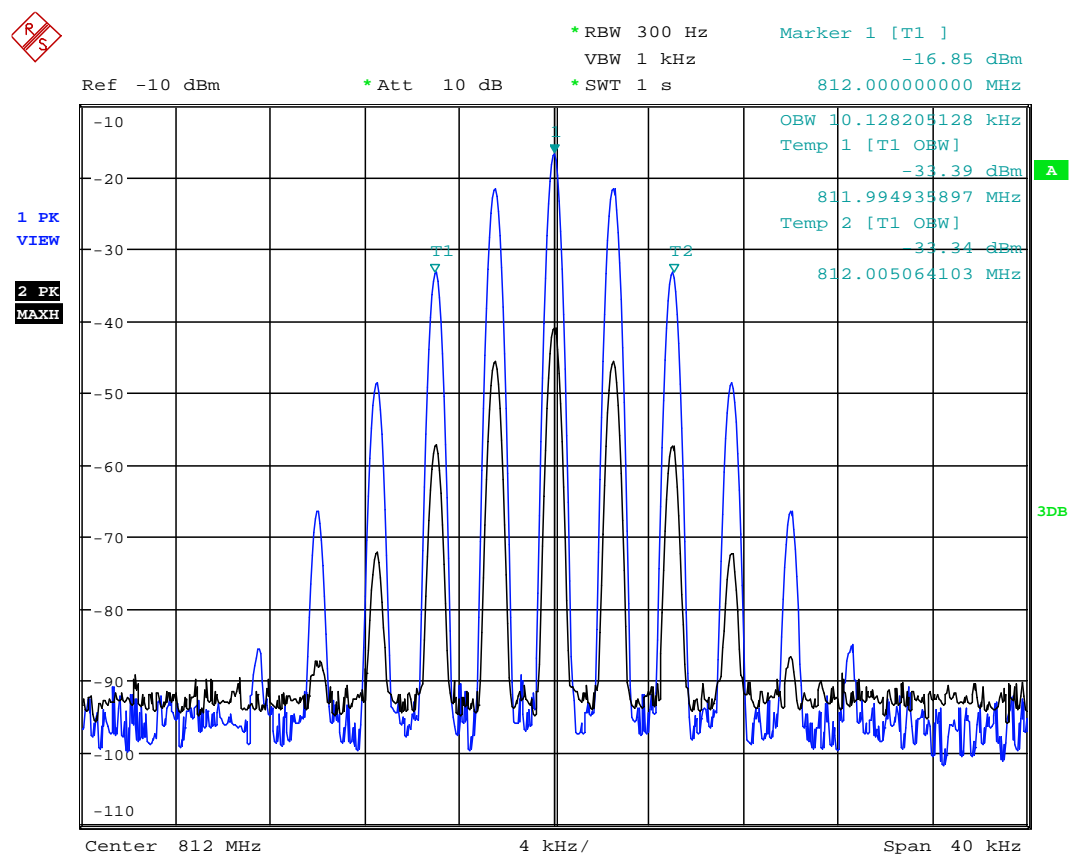

Date: 23.MAY.2011 12:57:51

814.0 MHz Signal Generator and EUT deviation set to 2.5 kHz FM

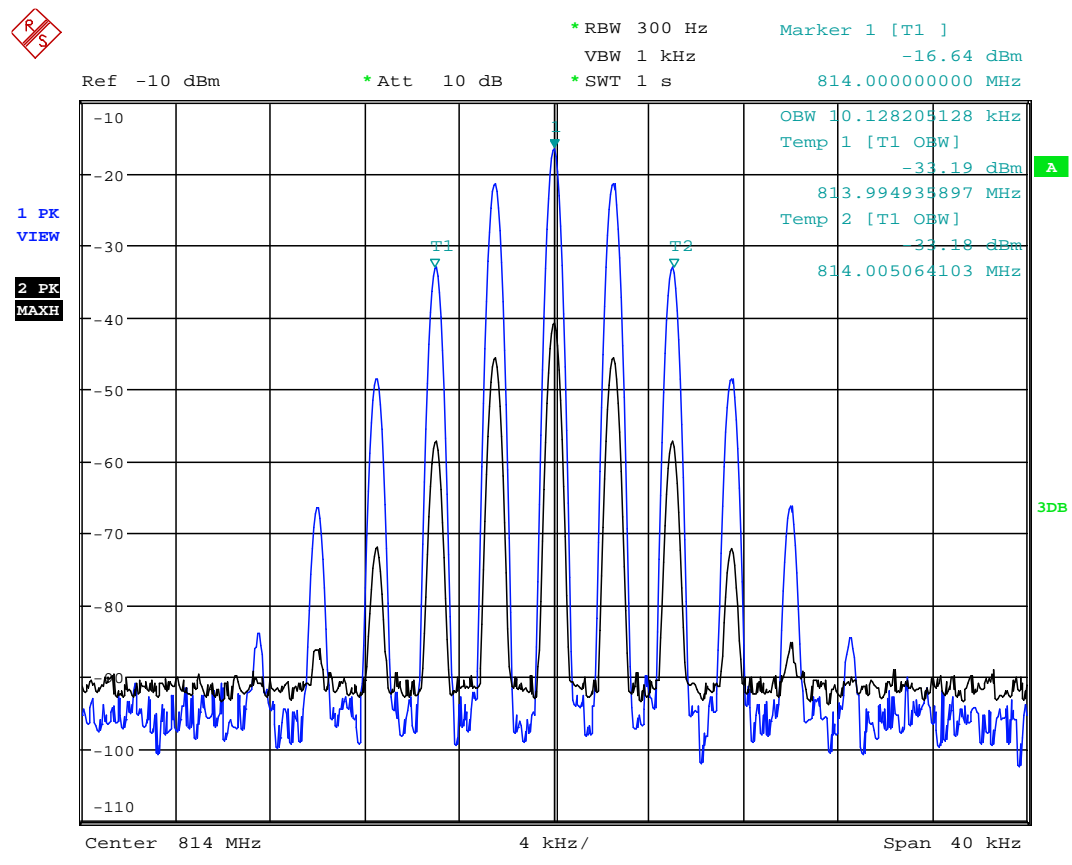

Date: 23.MAY.2011 12:55:43

816.0 MHz Signal Generator and EUT deviation set to 2.5 kHz FM

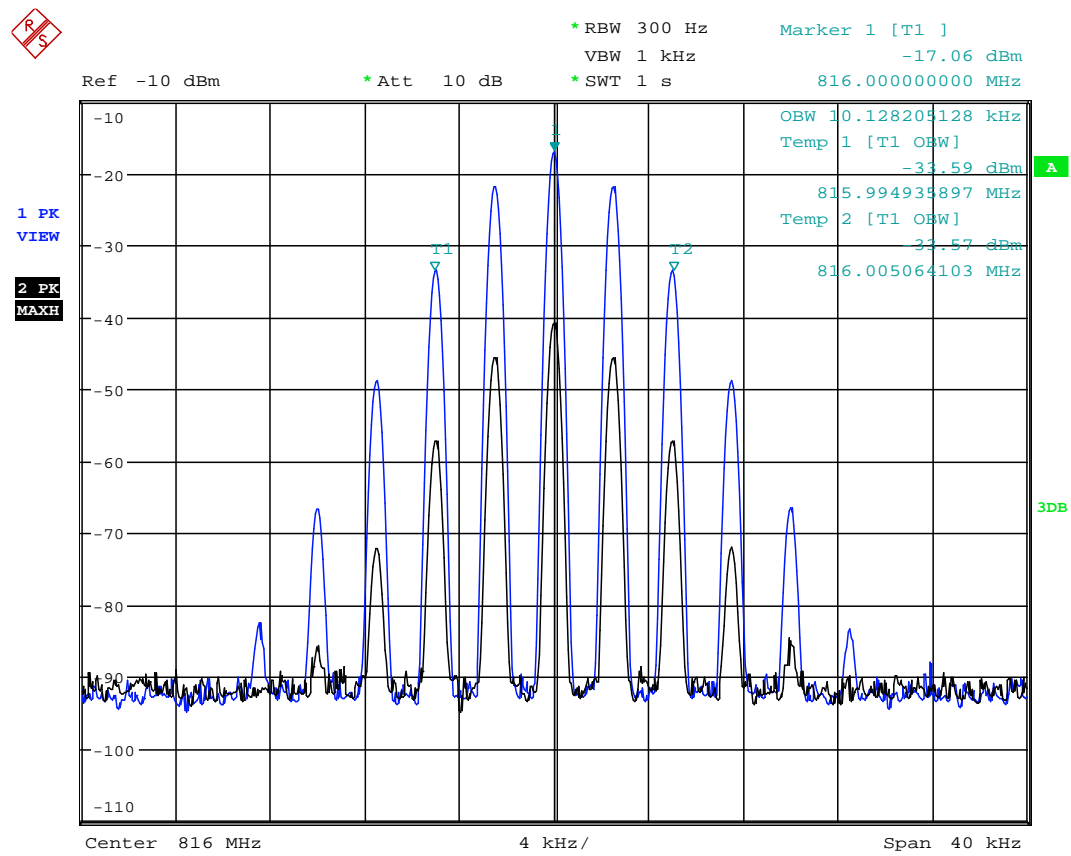

Date: 23.MAY.2011 13:00:05

The above plots depicting the output waveshape show no measurable distortion visible when compared to the input signal.

TRANSMITTER TESTS

AMPLIFIER SPURIOUS EMISSIONS – CONDUCTED – Part 2.1053 – 800MHz UPLINK

Ambient temperature = 24°C
 Relative humidity = 50%
 Supply voltage = +110Vac

Radio Laboratory
 Test Signal = F3E

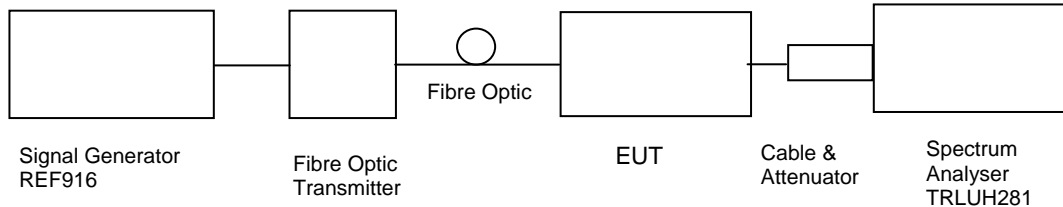

The test was set up as per the diagram. The level at the input was adjusted to compensate for the loss of the interconnecting cable. The unit was tested operating at maximum power and on three test frequencies.

The Spurious limit was calculated as follows:

On any frequency removed from the assigned frequency by more that 250% of the authorised bandwidth

At least $43 + 10 \log P_{dB}$

$$(10 \log P_{\text{watts}}) - (43 + 10 \log (P_{\text{watts}} * 1000)) = \text{LIMIT} = -13 \text{ dBm}$$

RESULTS

FREQUENCY RANGE	CHANNEL	EMISSION FREQ. (MHz)	EMISSION LEVEL (dBm)	LIMIT (dBm)
30MHz – 8.2 GHz	Bottom	1624.019	-32.2	-13
30MHz – 8.2 GHz	Middle	1628.002	-31.9	-13
30MHz – 8.2 GHz	Top	1631.992	-33.1	-13

The test equipment used for the Transmitter Conducted Emissions:

TYPE OF EQUIPMENT	MAKER/SUPPLIER	MODEL No	SERIAL No	TRL No	ACTUAL EQUIPMENT USED
SPECTRUM ANALYSER	RHODE & SCHWARZ	FSU46	200034	UH281	X
ATTENUATOR	HP	11708A	37341	UH287	X
ATTENUATOR	BIRD	8304-100-N	N/A	222	X
CABLE	TRL	N/A	N/A	UH358	X
CABLE	TRL	N/A	N/A	UH273	X
SIGNAL GENERATOR	RHODE & SCHWARZ	SMBV100	255812	REF916	X

Conducted emissions Bottom Channel

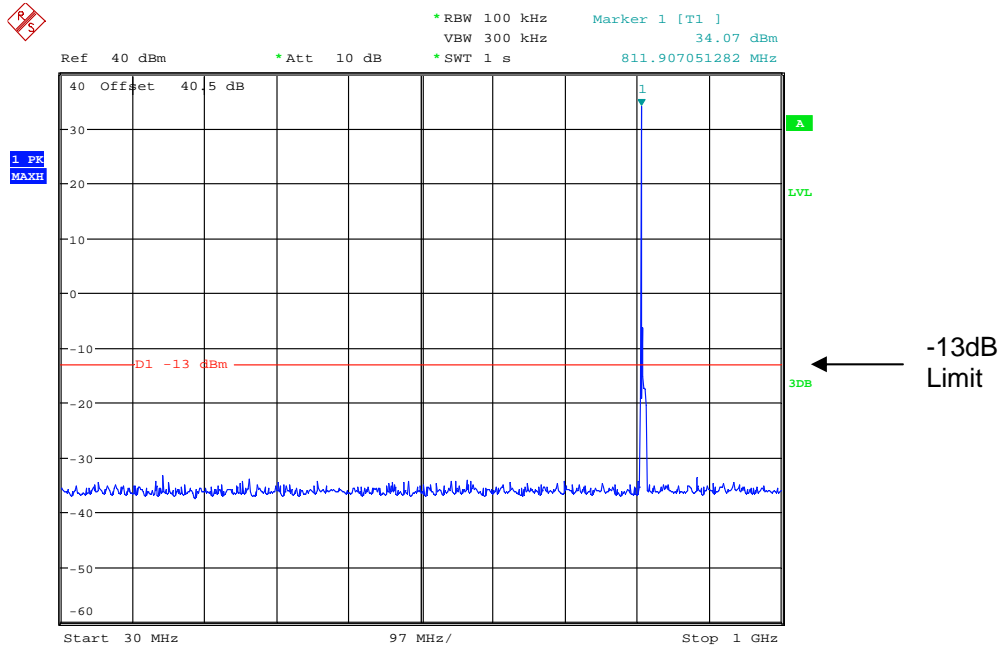

Date: 23.MAY.2011 11:47:43

30MHz – 1GHz

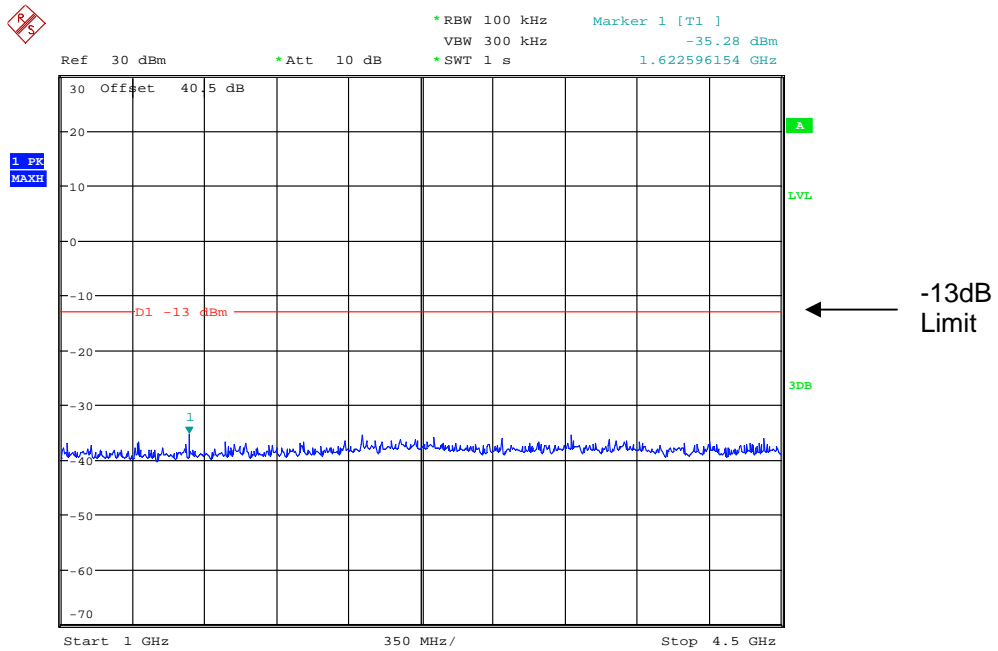

Date: 23.MAY.2011 11:48:49

1GHz – 4.5GHz

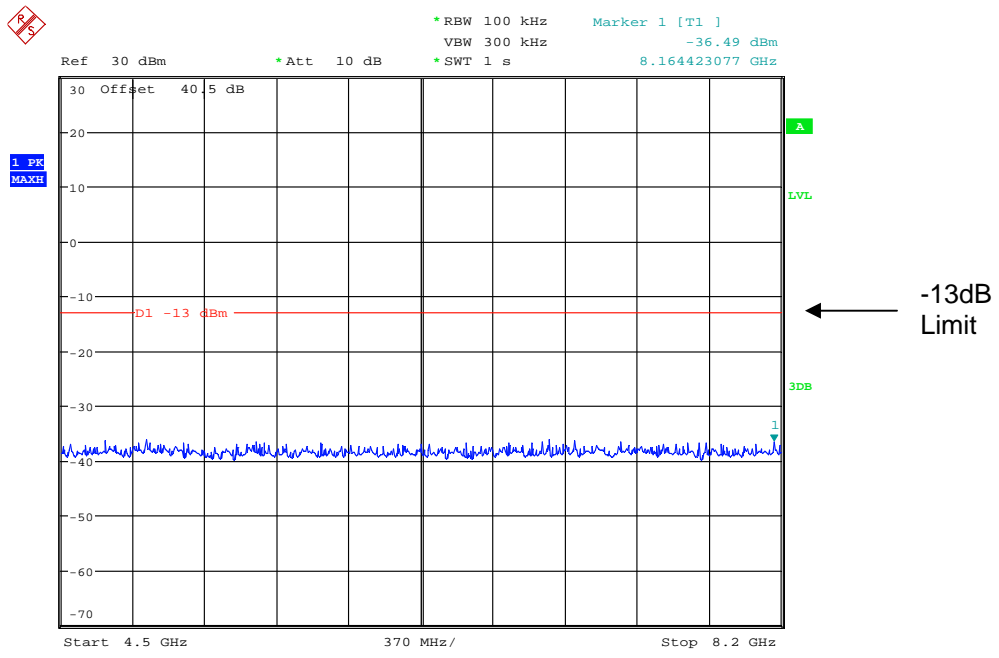

Date: 23.MAY.2011 11:48:33

4.5GHz – 8.2GHz

Conducted emissions Middle Channel

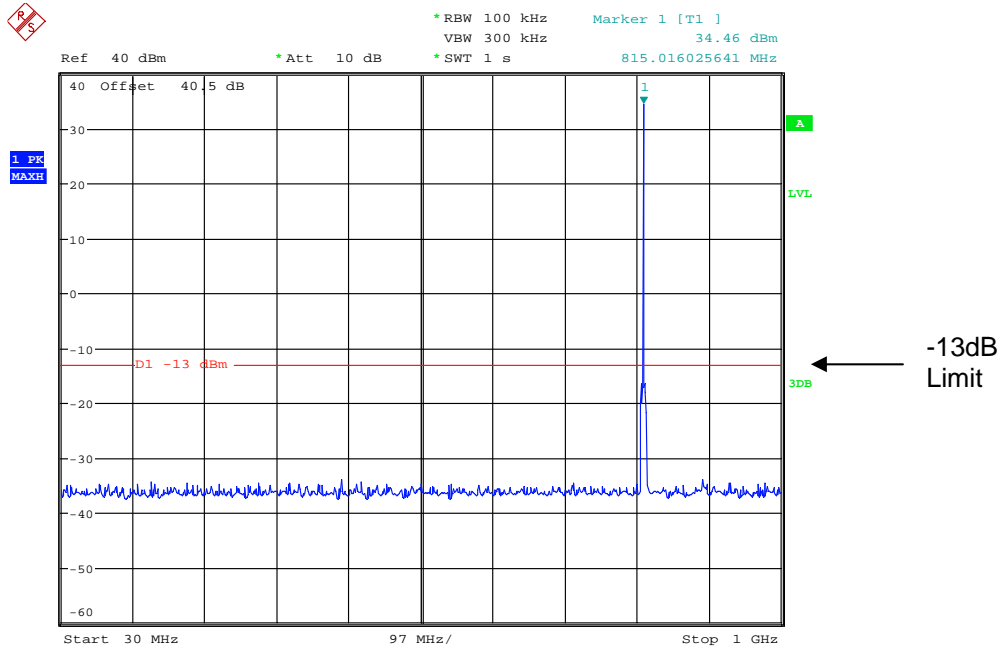

Date: 23.MAY.2011 11:47:24

30MHz – 1GHz

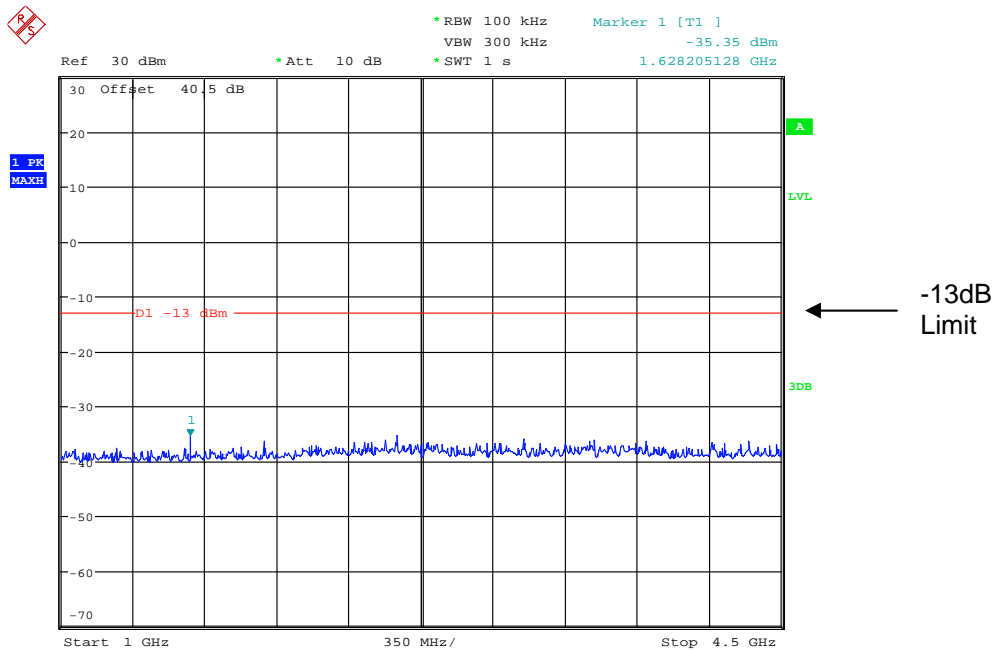

Date: 23.MAY.2011 11:47:04

1GHz – 4.5GHz

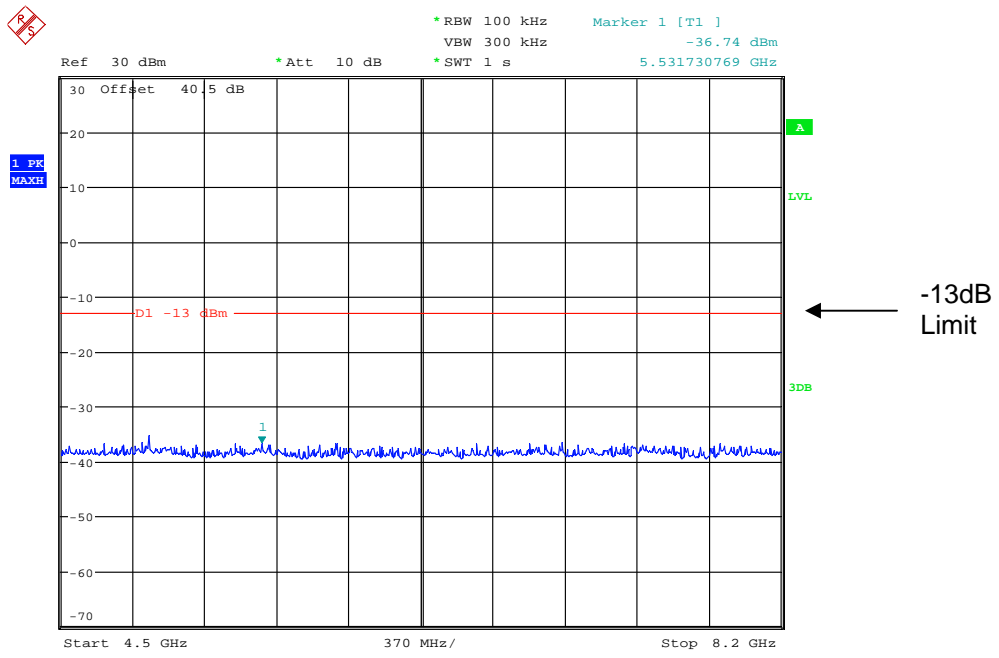

Date: 23.MAY.2011 11:46:47

4.5GHz – 8.2GHz

Conducted emissions Top Channel

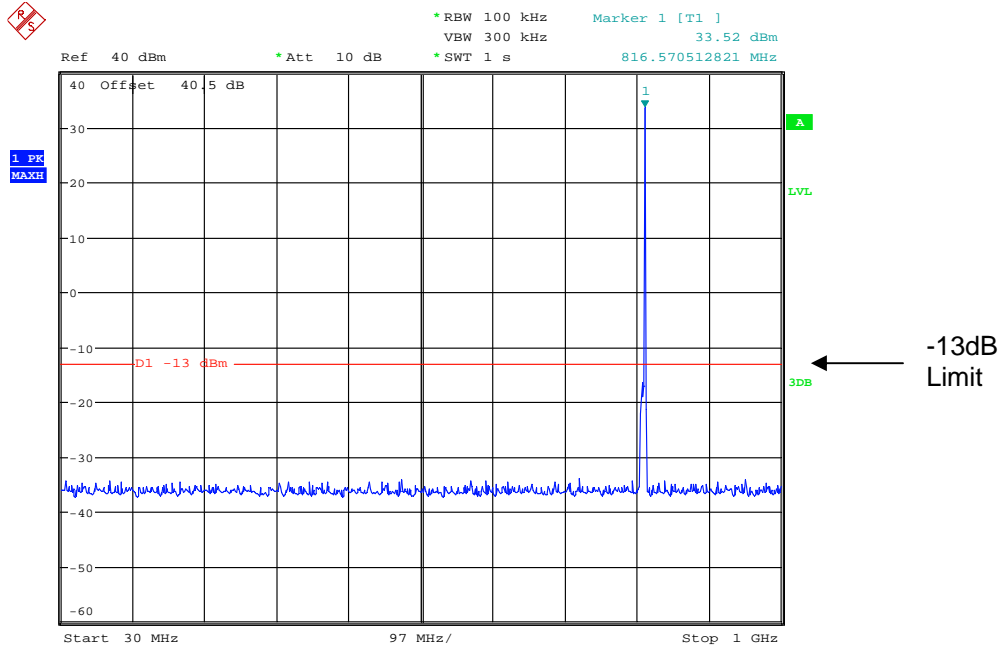

Date: 23.MAY.2011 11:47:58

30MHz – 1GHz

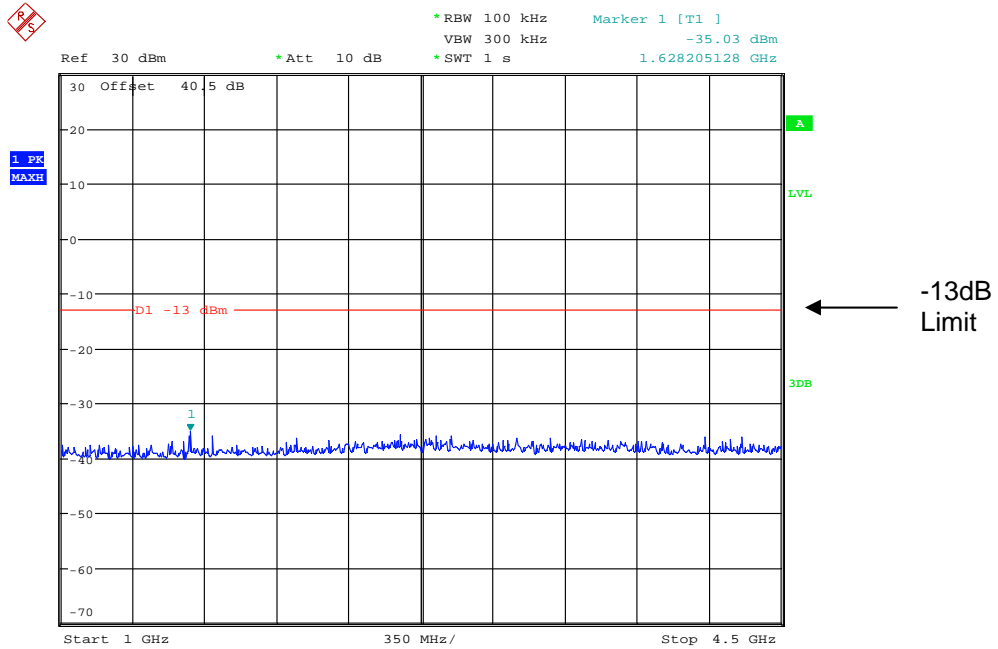

Date: 23.MAY.2011 11:45:32

1GHz – 4.5GHz

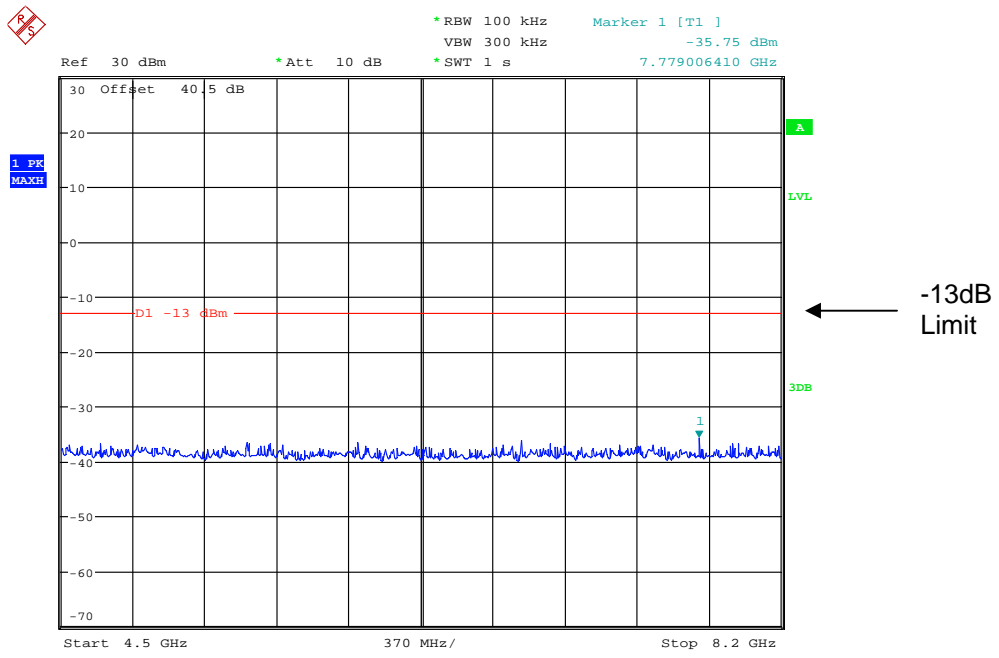

Date: 23.MAY.2011 11:48:18

4.5GHz – 8.2GHz

AMPLIFIER SPURIOUS EMISSIONS – RADIATED – Part 2.1053– 800MHz UPLINK

Ambient temperature = 22°C Test Signal = F3E
 Relative humidity = 462%
 Conditions = OATS
 Supply voltage = +230Vac
 Supply Frequency = N/A

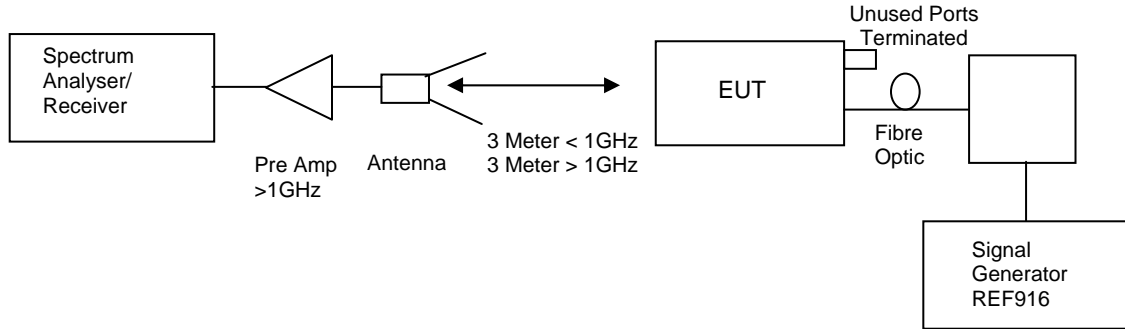

The test was set up as per the diagram. The level at the input was adjusted to compensate for the loss of the interconnecting cable. The unit was tested operating maximum power on three test frequencies with a 50 ohm load on the output. The unit was also tested with the signal generator replaced by another 50ohm load.

The Spurious limit was calculated as follows:

On any frequency removed from the assigned frequency by more that 250% of the authorised bandwidth

At least $43 + 10 \log P_{dB}$

$$(10 \log P_{watts}) - (43 + 10 \log (P_{watts} * 1000)) = \text{LIMIT} = -13 \text{ dBm}$$

RESULTS

FREQUENCY RANGE	FREQ. (MHz)	MEAS. Rx. (dBµV)	CABLE LOSS (dB)	ANT FACTOR	FIELD STRENGTH (dBµV/m)	CALCULATED EIRP (dBm)	LIMIT (dBm)
30MHz – 8.2GHz	No Significant Emissions Within 20dB of Limit.						-13

The test equipment used for the Transmitter Spurious Emissions:

TYPE OF EQUIPMENT	MAKER/SUPPLIER	MODEL No	SERIAL No	TRL No	ACTUAL EQUIPMENT USED
HORN	EMCO	3115	9010-3580	138	X
SPECTRUM ANALYSER	R&S	FSU46	200034	UH281	X
PRE AMPLIFIER	HP	8449B	3008A016	572	X
SIGNAL GENERATOR	RHODE & SCHWARZ	SMBV100	255812	REF916	X
ANTENNA	YORK	CBL611/A	1618	UH191	X

Radiated emissions Bottom Channel

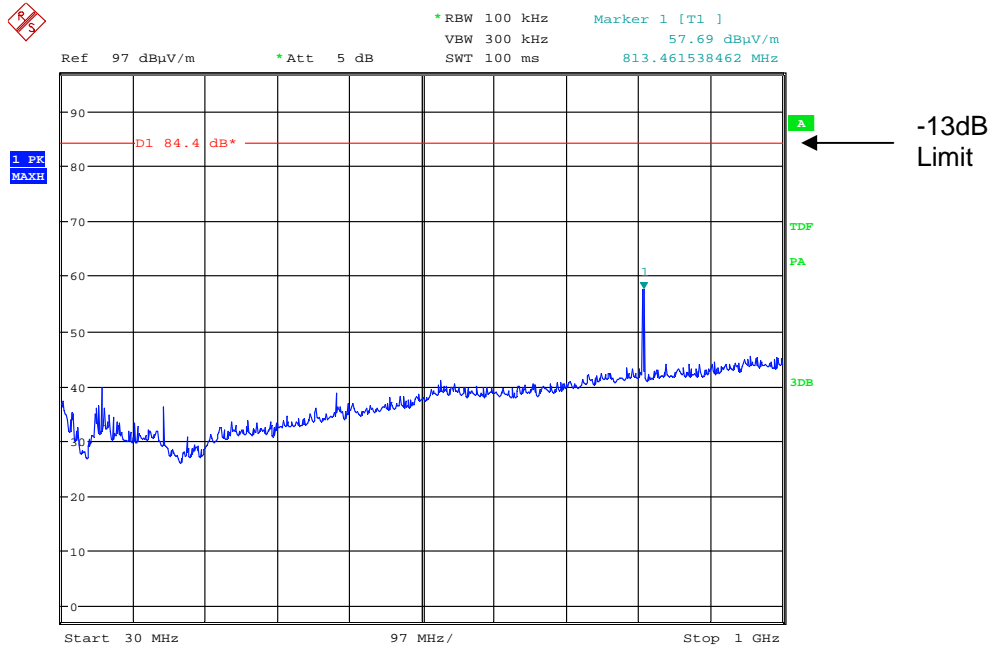

Date: 20.MAY.2011 10:14:46

30MHz – 1GHz

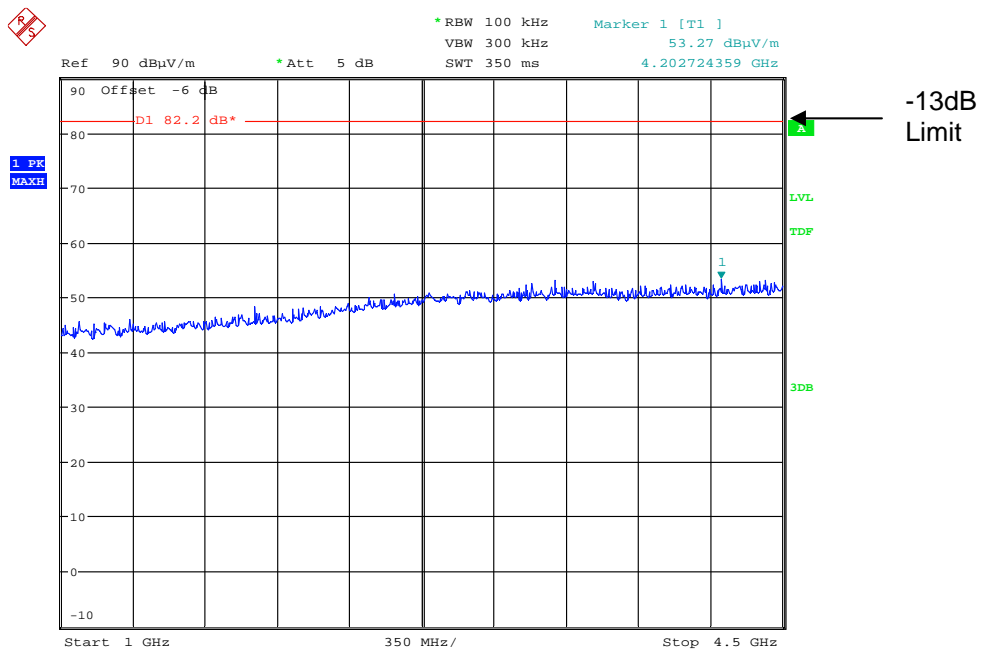

Date: 20.MAY.2011 10:09:11

1GHz – 4.5GHz

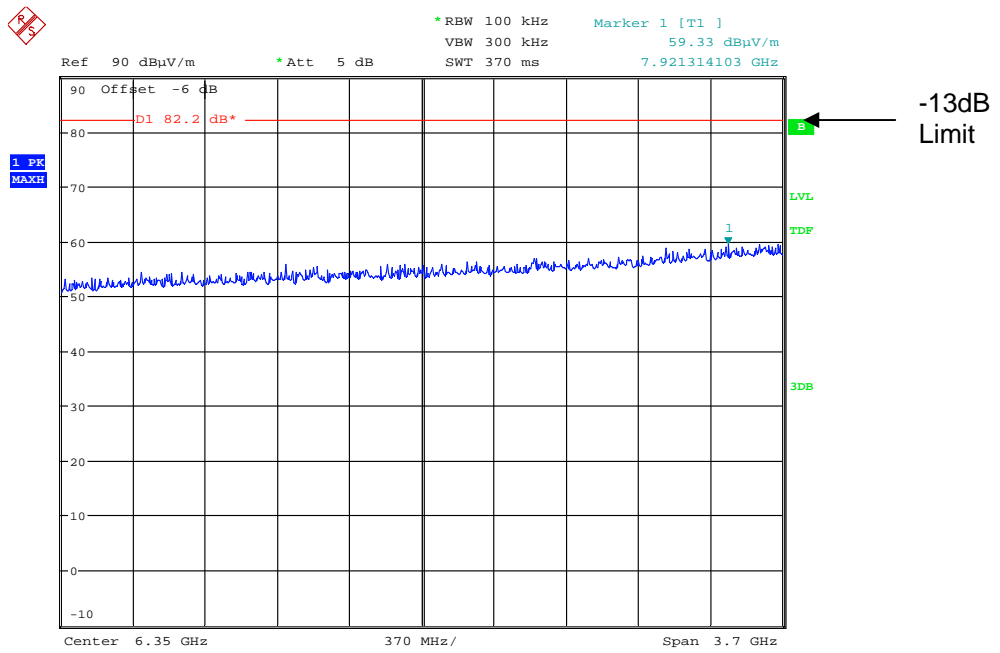

4.5GHz – 8.2GHz

The above test results show that there were no emissions within 20dBs of the -13dBm limit.

Radiated emissions Middle Low Channel

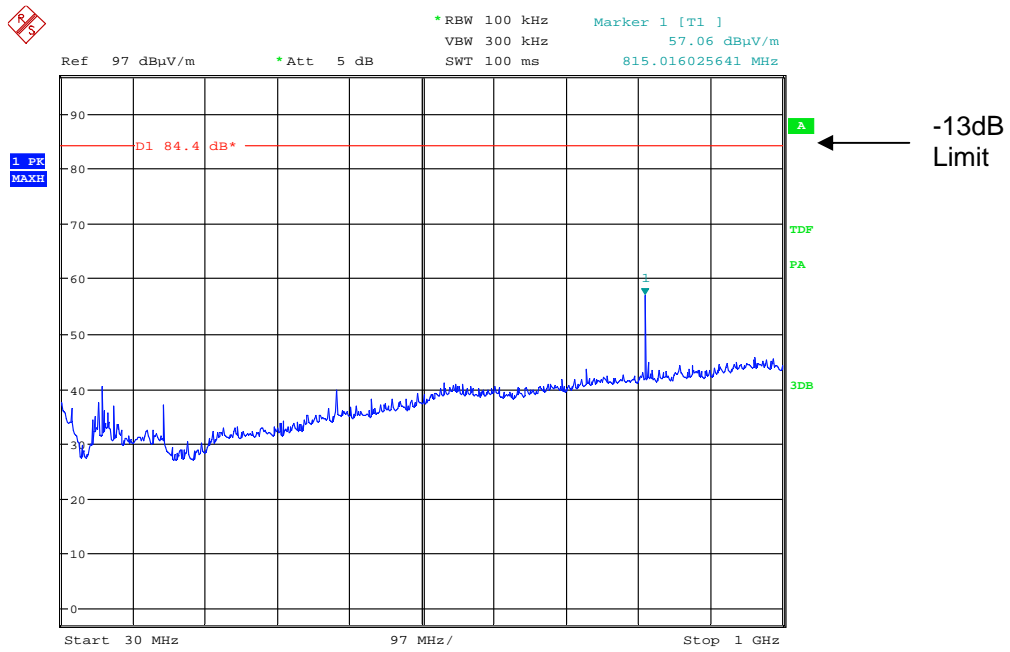

Date: 20.MAY.2011 10:30:01

30MHz – 1GHz

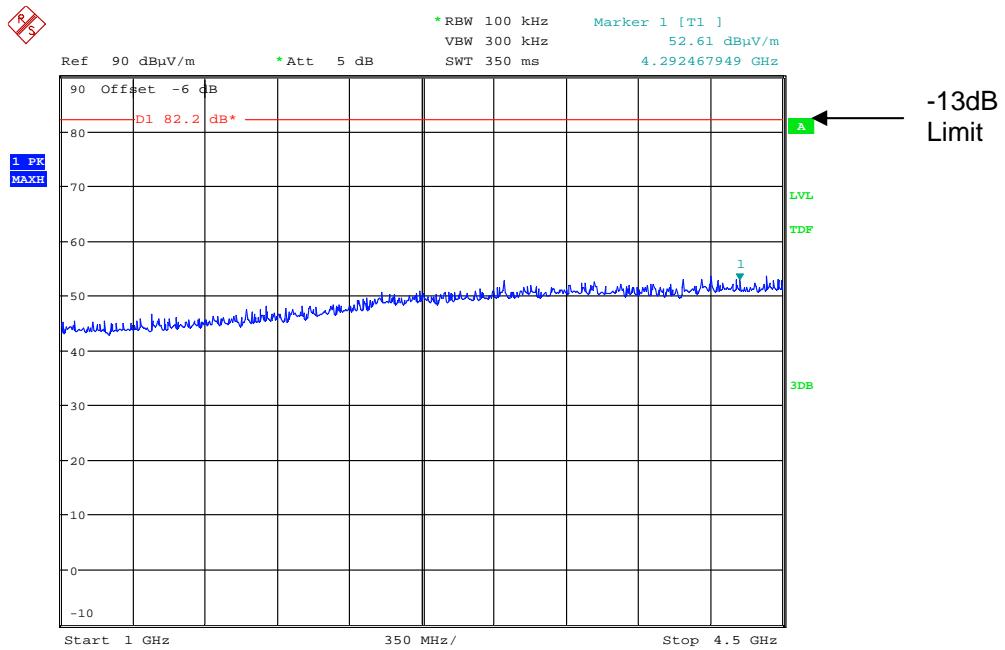

Date: 20.MAY.2011 10:08:06

1GHz – 4.5GHz

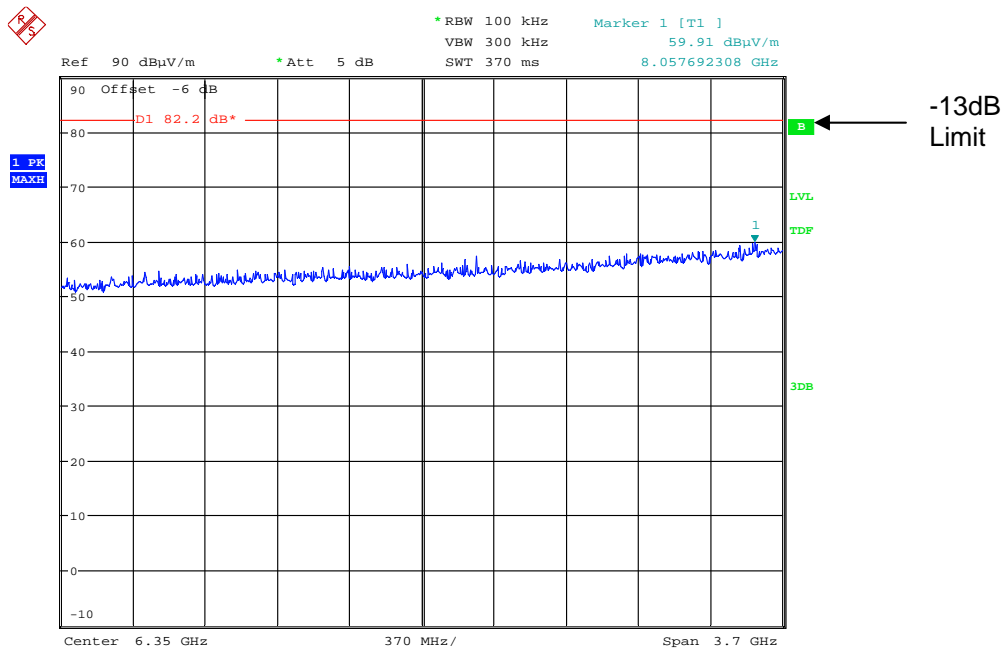

Date: 20.MAY.2011 10:08:27

4.5GHz – 8.2GHz

The above test results show that there were no emissions within 20dBs of the -13dBm limit.

Radiated emissions Top Channel

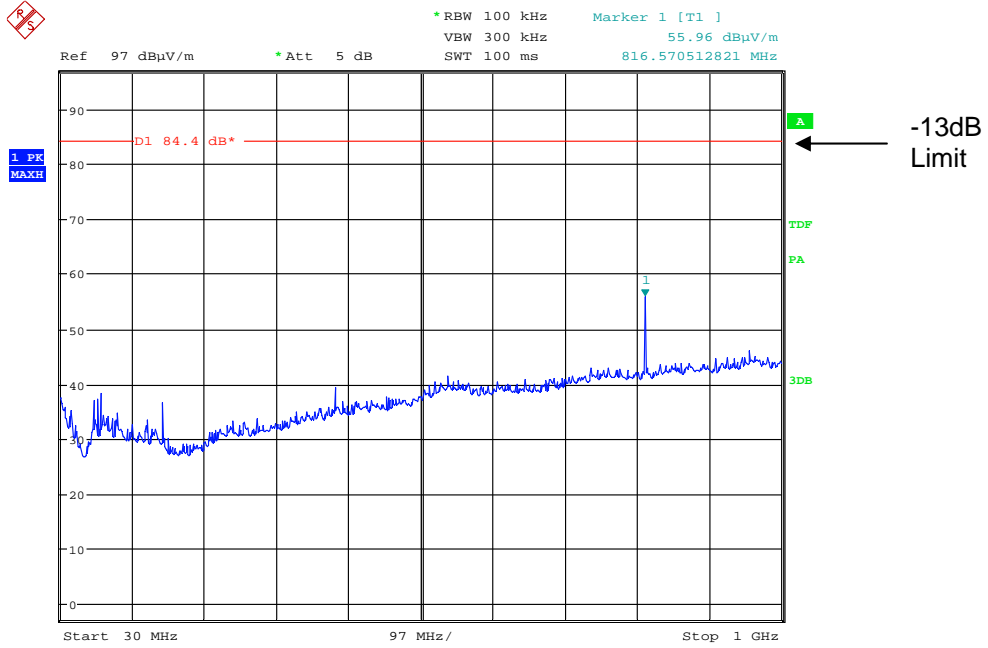

Date: 20.MAY.2011 10:30:23

30MHz – 1GHz

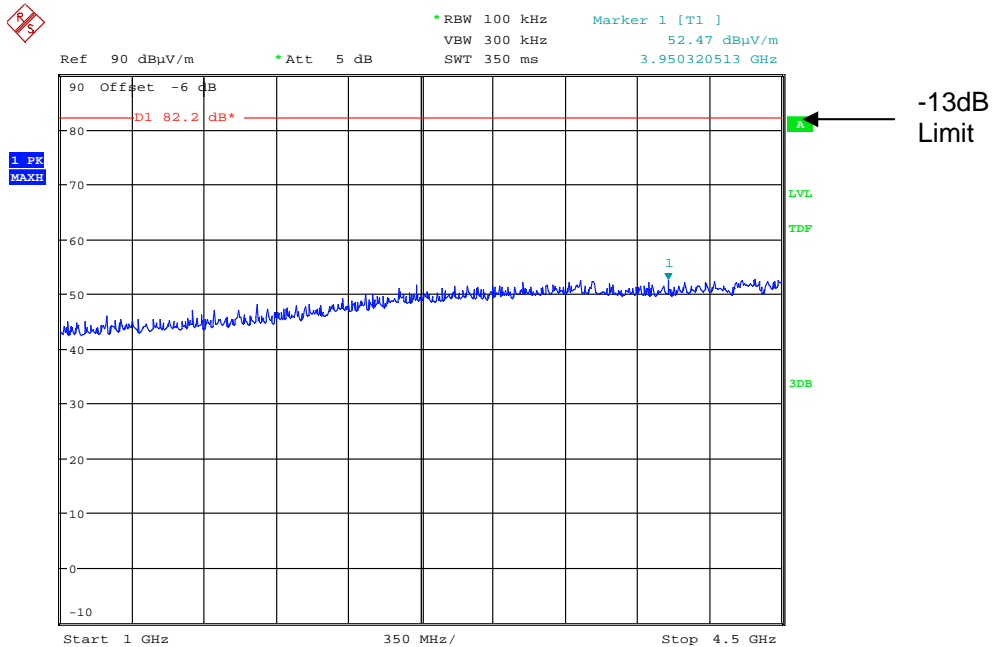

Date: 20.MAY.2011 10:07:29

1GHz – 4.5GHz

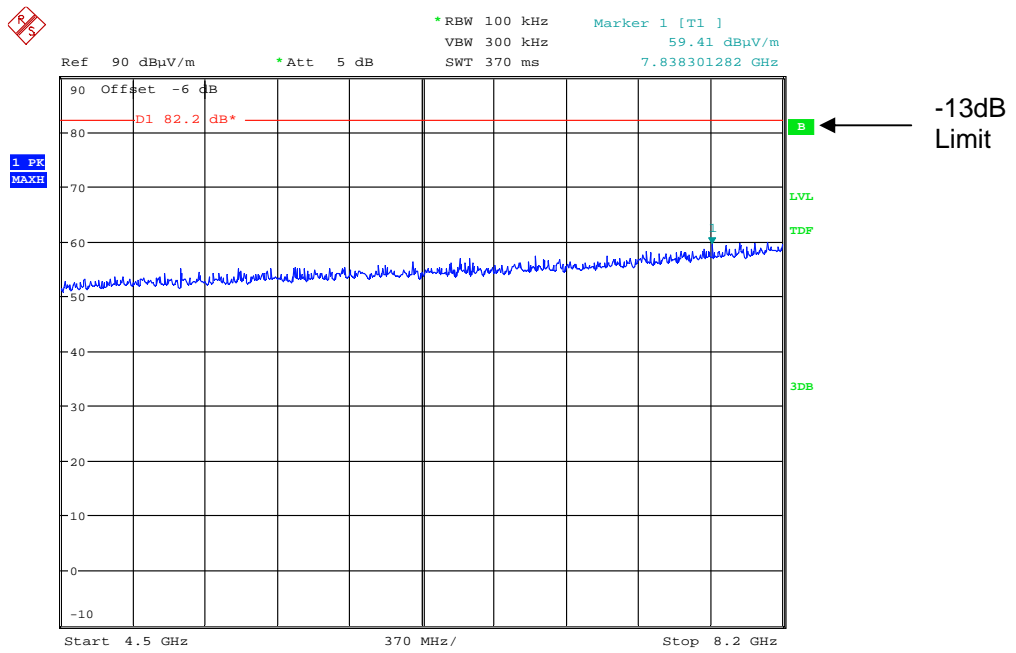

Date: 20.MAY.2011 10:06:58

4.5GHz – 8.2GHz

The above test results show that there were no emissions within 20dBs of the -13dBm limit.

ANNEX A
PHOTOGRAPHS





ANNEX B
APPLICANT'S SUBMISSION OF DOCUMENTATION LIST

APPLICANT'S SUBMISSION OF DOCUMENTATION LIST

a.	TCB	-	APPLICATION	[X]
		-	FEE	[X]
b.	AGENT'S LETTER OF AUTHORISATION	-		[X]
c.	MODEL(s) vs IDENTITY	-		[]
d.	ALTERNATIVE TRADE NAME DECLARATION(s)	-		[]
e.	LABELLING	-	PHOTOGRAPHS	[]
		-	DECLARATION	[]
		-	DRAWINGS	[]
f.	TECHNICAL DESCRIPTION	-		[X]
g.	BLOCK DIAGRAMS	-	Tx	[X]
		-	Rx	[]
		-	PSU	[]
		-	AUX	[]
h.	CIRCUIT DIAGRAMS	-	Tx	[X]
		-	Rx	[]
		-	PSU	[]
		-	AUX	[]
i.	COMPONENT LOCATION	-	Tx	[]
		-	Rx	[]
		-	PSU	[]
		-	AUX	[]
j.	PCB TRACK LAYOUT	-	Tx	[]
		-	Rx	[]
		-	PSU	[]
		-	AUX	[]
k.	BILL OF MATERIALS	-	Tx	[X]
		-	Rx	[]
		-	PSU	[]
		-	AUX	[]
l.	USER INSTALLATION / OPERATING INSTRUCTIONS	-		[X]

ANNEX C
EQUIPMENT CALIBRATION

REF Number	Equipment Type	Manufacturer	Last Cal Calibration	Calibration Period	Due For Calibration
UH003	Receiver	R&S	13/01/2011	12	13/01/2012
UH004	Receiver	R&S	14/12/2010	12	14/12/2011
UH06/07	IC OATS Submission	TRL	02/07/2009	24	02/07/2011
UH06/07	NSA Calibration	TRL	24/06/2010	12	24/06/2011
UH093	Bilog	Chase	03/06/2009	24	03/06/2011
UH191	Bilog	Chase	08/11/2010	24	08/11/2012
UH253	1m Cable N type	TRL	01/03/2011	12	01/03/2012
UH254	1m Cable N type	TRL	01/03/2011	12	01/03/2012
UH269	1m Cable N type	TRL	01/03/2011	12	01/03/2012
UH270	1m Cable N type	TRL	01/03/2011	12	01/03/2012
UH271	1.5m Cable N type	TRL	01/03/2011	12	01/03/2012
UH272	1.5m Cable N type	TRL	01/03/2011	12	01/03/2012
UH273	2m Cable N type	TRL	01/03/2011	12	01/03/2012
UH274	2m Cable N type	TRL	01/03/2011	12	01/03/2012
UH281	Spectrum Analyser	R&S	10/02/2011	12	10/02/2012
UH288	1m Cable N type	N/A	01/03/2011	12	01/03/2012
UH293	K-Type Cable	Megaphase	24/11/2010	12	24/11/2011
UH372	PreAmp	Wat-John	14/04/2010	12	14/04/2011
UH377	ESU 26	R&S	11/06/2010	13	11/07/2011
UH378	3M Cable	TRaC	01/03/2011	12	01/03/2012
UH387	Chamber 1	Rainford EMC	26/06/2010	12	26/06/2011
UH388	Chamber 2	Rainford EMC	23/06/2010	12	23/06/2011
L138	1-18GHz Horn	EMCO	10/09/2009	24	10/09/2011
L139	1-18GHz Horn	EMCO	17/08/2009	24	17/08/2011
L176	Signal Generator	Marconi	08/07/2010	12	08/07/2011
L254	Signal Generator	Marconi	15/09/2010	12	15/09/2011
L572	Pre Amp	Agilent	24/11/2010	12	24/11/2011
L664	3M Cable	TRaC	01/03/2011	12	01/03/2012
REF910	Spectrum Analyser	R&S	27/10/2010	12	27/10/2011
REF916	Signal Generator	R&S	13/12/2010	12	13/12/2011
TRL170	Combiner	Elcom		Calibrate in use	

ANNEX D
MEASUREMENT UNCERTAINTY

Radio Testing – General Uncertainty Schedule

All statements of uncertainty are expanded standard uncertainty using a coverage factor of 1.96 to give a 95% confidence where no required test level exists.

[1] Adjacent Channel Power

Uncertainty in test result = **1.86dB**

[2] Carrier Power

Uncertainty in test result (Equipment - TRLUH120) = **2.18dB**

Uncertainty in test result (Equipment – TRL05) = **1.08dB**

Uncertainty in test result (Equipment – TRL479) = **2.48dB**

[3] Effective Radiated Power

Uncertainty in test result = **4.71dB**

[4] Spurious Emissions

Uncertainty in test result = **4.75dB**

[5] Maximum frequency error

Uncertainty in test result (Equipment - TRLUH120) = **119ppm**

Uncertainty in test result (Equipment – TRL05) = **0.113ppm**

Uncertainty in test result (Equipment – TRL479) = **0.265ppm**

[6] Radiated Emissions, field strength OATS 14kHz-18GHz Electric Field

Uncertainty in test result (14kHz – 30MHz) = **4.8dB**, Uncertainty in test result (30MHz – 1GHz) = **4.6dB**,

Uncertainty in test result (1GHz-18GHz) = **4.7dB**

[7] Frequency deviation

Uncertainty in test result = **3.2%**

[8] Magnetic Field Emissions

Uncertainty in test result = **2.3dB**

[9] Conducted Spurious

Uncertainty in test result (Equipment TRL479) Up to 8.1GHz = **3.31dB**

Uncertainty in test result (Equipment TRL479) 8.1GHz – 15.3GHz = **4.43dB**

Uncertainty in test result (Equipment TRL479) 15.3GHz – 21GHz = **5.34dB**

Uncertainty in test result (Equipment TRLUH120) Up to 26GHz = **3.14dB**

[10] Channel Bandwidth

Uncertainty in test result = **15.5%**

[11] Amplitude and Time Measurement – Oscilloscope

Uncertainty in overall test level = **2.1dB**, Uncertainty in time measurement = **0.59%**, Uncertainty in Amplitude measurement = **0.82%**

[11] Power Line Conduction

Uncertainty in test result = **3.4dB**

[12] Spectrum Mask Measurements

Uncertainty in test result = **2.59% (frequency)**
Uncertainty in test result = **1.32dB (amplitude)**

[13] Adjacent Sub Band Selectivity

Uncertainty in test result = **1.24dB**

[14] Receiver Blocking – Listen Mode, Radiated

Uncertainty in test result = **3.42dB**

[15] Receiver Blocking – Talk Mode, Radiated

Uncertainty in test result = **3.36dB**

[16] Receiver Blocking – Talk Mode, Conducted

Uncertainty in test result = **1.24dB**

[17] Receiver Threshold

Uncertainty in test result = **3.23dB**

[18] Transmission Time Measurement

Uncertainty in test result = **7.98%**



HULL

Unit E, South Orbital Trading Park, Hedon Road, Hull, HU9 1NJ, UK.
T +44 (0)1482 801801 F +44 (0)1482 801806 E test@tracglobal.com
www.tracglobal.com