



TEST REPORT
FOR
AXELL WIRELESS
ON
510 MHz U/L FO BOOSTER AMPLIFIER
DOCUMENT NO. TTR-005045WUS4

TEST REPORT NO: TTR-005045WUS4
COPY NO: 1
ISSUE NO: 1
FCC ID: NEO-274801

**REPORT ON THE CERTIFICATION TESTING OF A
AXELL WIRELESS
UHF U/L FO BOOSTER AMPLIFIER
WITH RESPECT TO
THE FCC RULES CFR 47,
PART 90**

PRIVATE LAND MOBILE REPEATER.



TEST DATE: 16th – 20th May 2011

APPROVED BY:  J CHARTERS
PRODUCT MANAGER

DATE: 6th June 2011

Distribution:
Copy Nos: 1. Axell Wireless
2. TRaC Telecoms and Radio

CONTENTS

	PAGE		
CERTIFICATE OF CONFORMITY & COMPLIANCE	4		
APPLICANT'S SUMMARY	5		
EQUIPMENT TEST CONDITIONS	6		
TESTS REQUIRED	6		
TEST RESULTS	7 – 27		
		ANNEX	
PHOTOGRAPHS		A	
PHOTOGRAPH No. 1&2: Test setup			
PHOTOGRAPH No. 3&4: Equipment overview			
APPLICANT'S SUBMISSION OF DOCUMENTATION LIST		B	
EQUIPMENT CALIBRATION		C	
MEASUREMENT UNCERTAINTY		D	
Notes:			
1. Component failure during test		YES	<input type="checkbox"/>
		NO	<input checked="" type="checkbox"/>
2. If Yes, details of failure:			
3. The facilities used for the testing of the product contain in this report are FCC Listed.			

CERTIFICATE OF CONFORMITY & COMPLIANCE

FCC IDENTITY: NEO-274801

PURPOSE OF TEST: Certification

TEST SPECIFICATION: FCC RULES CFR 47, Part 90

TEST RESULT: Compliant to Specification

EQUIPMENT UNDER TEST: UHF U/L FO Booster Amplifier

EQUIPMENT TYPE: Private Land Mobile Repeater

MAXIMUM GAIN: Uplink(UHF) = 59.05 dB

MAXIMUM INPUT: Uplink (UHF) = - 23.1 dBm

MAXIMUM OUTPUT CONDUCTED: Uplink (UHF) = +35.72 dBm

CHANNEL BANDWIDTH: N/A Wideband amplifier

FREQUENCY GENERATION: N/A

MODULATION TYPE: F3E

POWER SOURCE(s): +110V AC supply

TEST DATE(s): 16th – 20th May 2011

ORDER No(s): 72741

APPLICANT: Axell Wireless

ADDRESS: Aerial House
Asheridge Road
Chesham
Buckinghamshire
HP5 1TU

APPROVED BY:



J CHARTERS
PRODUCT
MANAGER

APPLICANT'S SUMMARY

EQUIPMENT UNDER TEST (EUT): UHF U/L FO Booster Amplifier

EQUIPMENT TYPE: Private Land Mobile Repeater

PURPOSE OF TEST: Certification

TEST SPECIFICATION(s): FCC RULES CFR 47, Part 90

TEST RESULT: COMPLIANT Yes
No

APPLICANT'S CATEGORY: MANUFACTURER
IMPORTER
DISTRIBUTOR
TEST HOUSE
AGENT

APPLICANT'S ORDER No(s): 72741

APPLICANT'S CONTACT PERSON(s): Mr Peter Bradfield

E-mail address: peter.bradfield@axellwireless.com

APPLICANT: Axell Wireless

ADDRESS: Aerial House
Asheridge Road
Chesham
Buckinghamshire
HP5 1TU
United Kingdom

TEL: +44 (0)1494 777000

FAX: +44 (0)1494 778456

MANUFACTURER: Axell Wireless

EUT(s) COUNTRY OF ORIGIN: United Kingdom

TEST LABORATORY: TRaC

TEST DATE(s): 16th – 20th May 2011

TEST REPORT No: TTR-005045WUS4

EQUIPMENT TEST / EXAMINATIONS REQUIRED

1.	Test/Examination	Rule Part	Applicability	Result
	RF Power Output	90.205	Yes	Complies
	Audio Frequency Response	TIA EIA-603.3.2.6	N/A	N/A
	Audio Low-Pass Filter Response	TIA EIA-603.3.2.6	N/A	N/A
	Modulation Limiting	TIA EIA-603.3.2.6	N/A	N/A
	Occupied Bandwidth	90.210	Yes	Complies
	Spurious Emissions at Antenna Terminals	90.210	Yes	Complies
	Field Strength of Spurious Emissions	90.210	Yes	Complies
	Frequency Stability	90.213	N/A(note 1)	N/A
	Transient behaviour	90.214	N/A(note 2)	N/A

Notes:

1 The EUT does not contain modulation circuitry; therefore the test was not performed.

2 The EUT is not a keyed carrier system; therefore the test was not performed.

2. Product class: Uplink Class A Class B
3. Product Use: Private Land Mobile Repeater
4. Emission Designator: F3E
5. Temperatures: Ambient (Tnom) 24°C
6. Supply Voltages: Vnom +110Vac
- Note: Vnom voltages are as stated above unless otherwise shown on the test report page
7. Equipment Category: Single channel
Two channel
Multi-channel
8. Channel spacing: Narrowband Uplink
9. Test Location: TRaC Skelmersdale
10. Modifications made during test program: No modifications were performed.

System description:

The UHF U/L FO Booster Amplifier system consists of a UHF uplink wideband amplifier. The wideband amplifier operates over the frequency band 509.5 MHz – 510.5 MHz

COMPLIANCE TESTS

AMPLIFIER GAIN – CONDUCTED – PART 2.1046 –UHF UPLINK

Ambient temperature = 24°C
 Relative humidity = 50%
 Supply voltage = +110Vac
 Channel number = See test results

Radio Laboratory

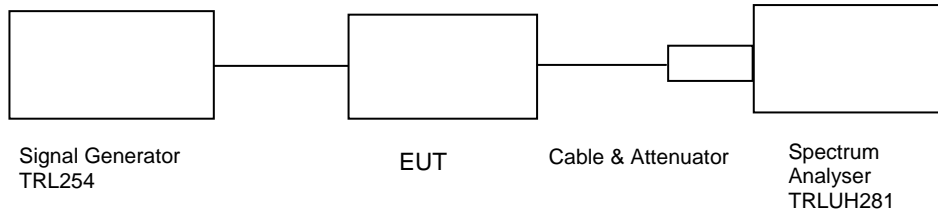

Frequency (MHz)	Signal Generator input level (dBm)	Input Cable Loss (dB)	Output Cable & Attenuator loss (dB)	Level at Spectrum Analyser (dBm)	Gain (dB)	Conducted Output Power (dBm)	Gain after 10dB input level increase (dB)
509.5	-23.00	0.10	40.2	-4.50	58.80	35.70	48.82
510.0	-23.80	0.10	40.2	-5.05	59.05	35.15	49.09
510.5	-23.70	0.10	40.2	-4.97	59.03	35.23	49.03
Notes:	1. The signal generator input was increased by 10dB and the level of the output signal remeasured.						

Equipment used for testing the amplifier gain:

Type Of Equipment	Maker/ Supplier	Model No.	Serial No.	TRL No.	Actual Equipment Used
Spectrum Analyser	Rohde & Schwarz	FSU46	200034	UH281	X
Attenuator	Bird	8308-200-N	N/A	103	X
Attenuator	Bird	8304-100-N	N/A	222	X
Cable	TRL	N/A	N/A	UH271	X
Cable	TRL	N/A	N/A	UH272	X
Cable	TRL	N/A	N/A	UH273	X
Signal Generator	Marconi	2042	119562/021	254	X

AMPLIFIER INTERMODULATION SPURIOUS EMISSIONS – CONDUCTED – PART 2.1053–UHF UPLINK

Ambient temperature = 22°C
 Relative humidity = 42%
 Supply voltage = +110Vac

Radio Laboratory

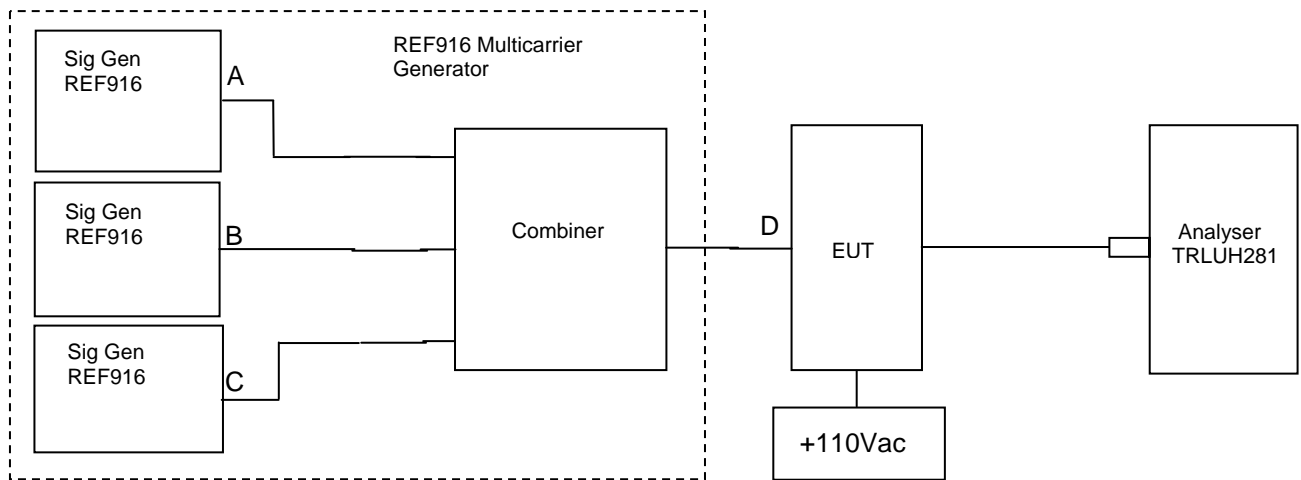

The intermodulation and spurious products were measured with the amplifier operating at maximum gain. A three tone test was conducted using the equipment as above. The input power level was adjusted so the level at point D was 10dB above the maximum input of -26dBm. The cable and attenuator loss between the EUT and the spectrum analyser was 35.8dB.

RF Input Frequency (MHz)			Highest Intermodulation Product Level (dBm)	Limit (dBm)
509.5	510	510.5	-13.27 dBm @ 510.125 MHz	-13

Sweep data is shown on the next page:

Test equipment used for intermodulation test:

Type Of Equipment	Maker/ Supplier	Model No.	Serial No.	TRL No.	Actual Equipment Used
Spectrum Analyser	Rohde & Schwarz	FSU46	200034	UH281	X
Signal Generator	Rohde & Schwarz	SMBV100	255812	REF916	X
Combiner	Elcom	RC-4-50	N/A	170	X
Cable	TRL	N/A	N/A	UH271	X
Cable	TRL	N/A	N/A	UH272	X
Cable	TRL	N/A	N/A	UH273	X
Cable	TRL	N/A	N/A	UH269	X

Intermodulation Close View

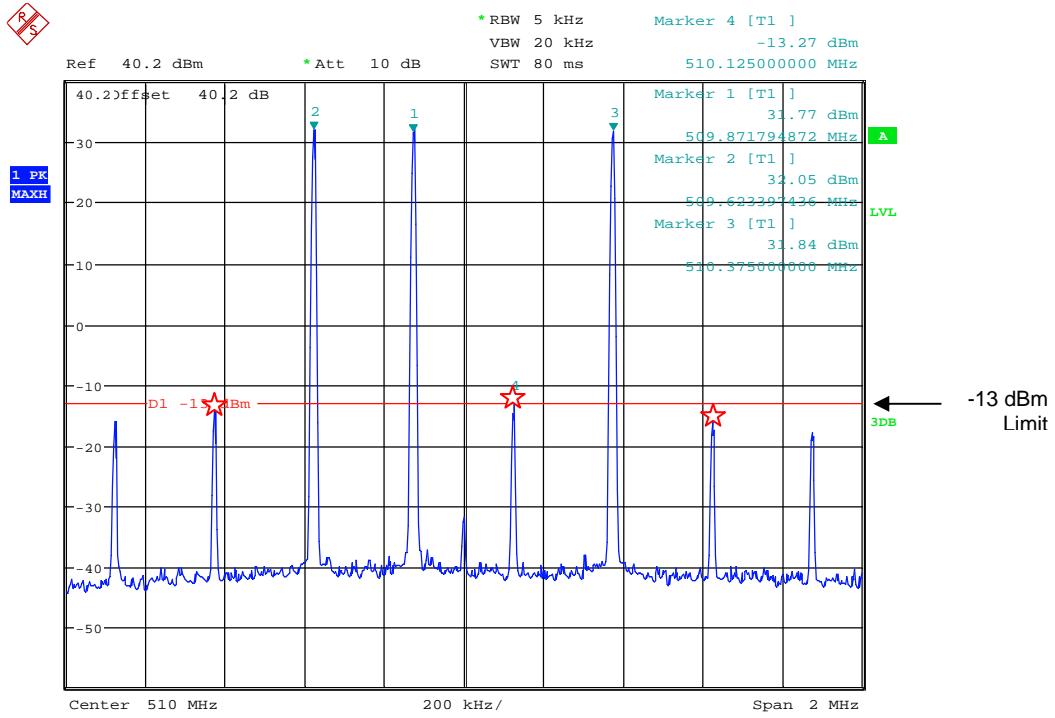

Date: 23.MAY.2011 10:49:18

Intermodulation Wide View

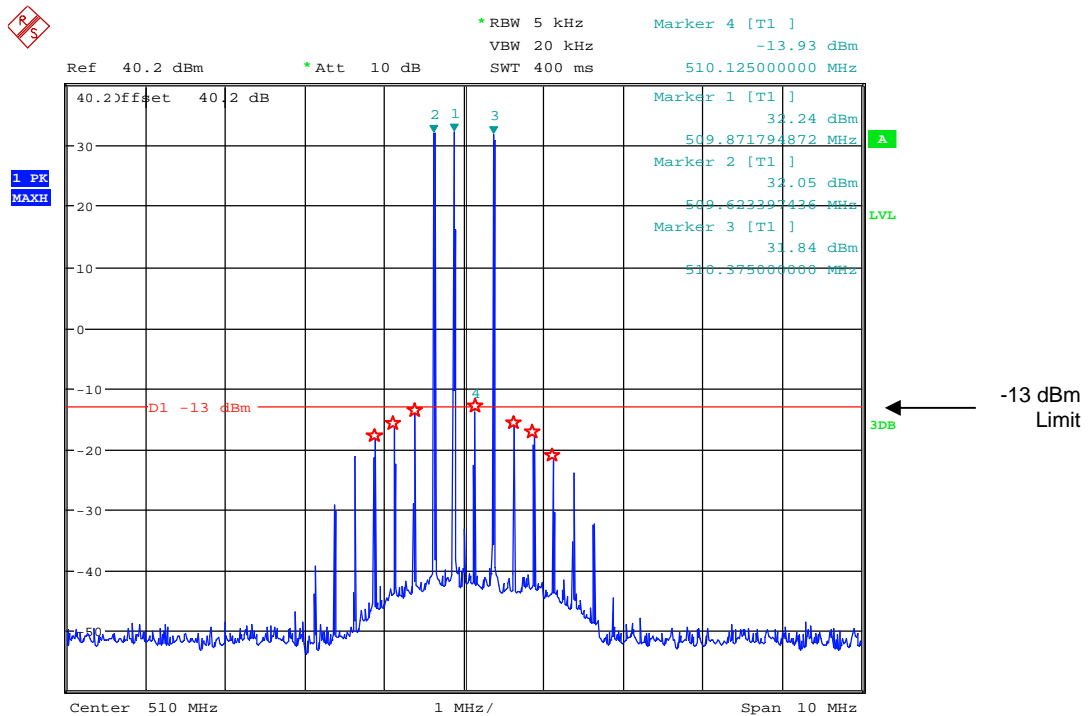

Date: 23.MAY.2011 10:49:30

The above plots show that all products (designated by a ☆) are below the spurious limit.

30 MHz – 1 GHz

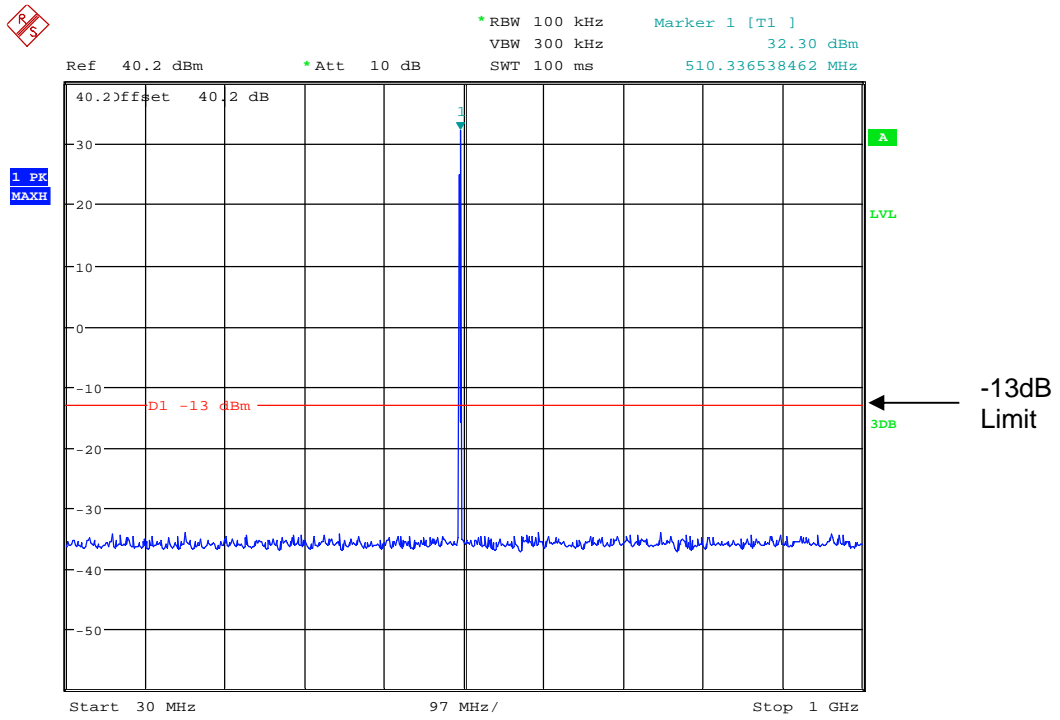

Date: 23.MAY.2011 10:49:57

1 GHz – 3 GHz

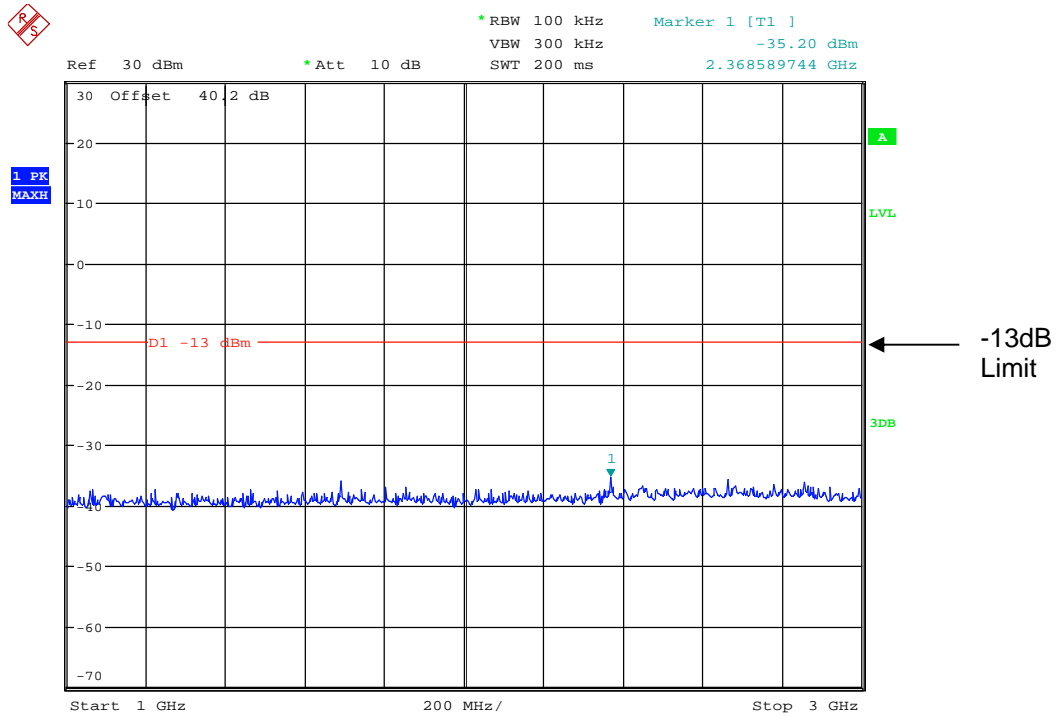

Date: 23.MAY.2011 10:51:32

3 GHz – 5 GHz

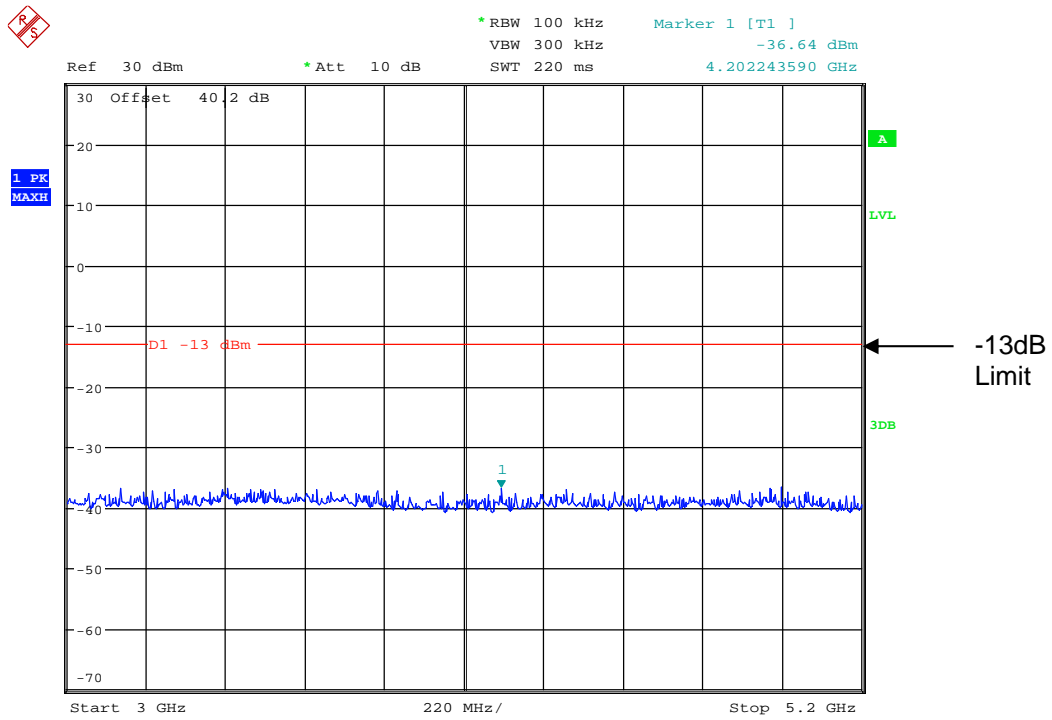

Date: 23.MAY.2011 10:51:03

TRANSMITTER TESTS

AMPLIFIER MODULATED CHANNEL TEST – CONDUCTED – Part 2.1049– UHF UPLINK

Ambient temperature = 22°C Radio Laboratory
 Relative humidity = 42%
 Supply voltage = +110Vac
 Channel number = See test results

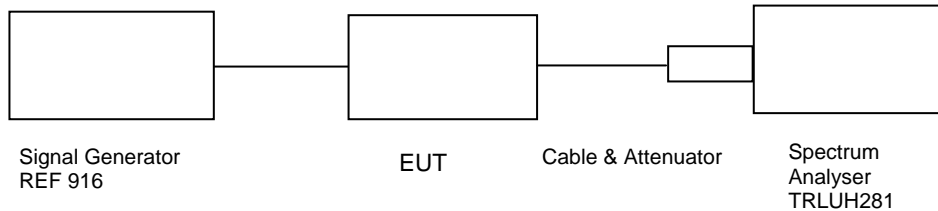

This test was performed to show that the amplifier does not alter the input signal in any way. The input signal was set to the maximum input and modulated with a 2500Hz tone. The plots show the signal measured at the signal generator and the signal measured at the output of the EUT.

Note: The cables and attenuators had the following losses.

1. Cable and attenuator between EUT and spectrum analyser 40.25dB
2. Cable between signal generator and EUT 0.17dB
3. See Table below for 99% Power Occupied Bandwidth

Frequency of Operating Channel	Modulation Type = 2.5kHz Deviation FM
509.5 MHz	99% Bandwidth = 10.128 kHz
510 MHz	99% Bandwidth = 10.128 kHz
510.5 MHz	99% Bandwidth = 10.128 kHz

Type Of Equipment	Maker/ Supplier	Model No.	Serial No.	TRL No.	Actual Equipment Used
Spectrum Analyser	Rohde & Schwarz	FSU46	200034	UH281	X
Attenuator	Bird	8308-200-N	N/A	103	X
Attenuator	Bird	8304-100-N	N/A	222	X
Cable	TRL	N/A	N/A	UH271	X
Cable	TRL	N/A	N/A	UH272	X
Cable	TRL	N/A	N/A	UH273	X
Signal Generator	Rohde & Schwarz	Vector Signal Generator	255812	916	X

509.5 MHz Signal Generator with deviation set to 2.5 kHz FM

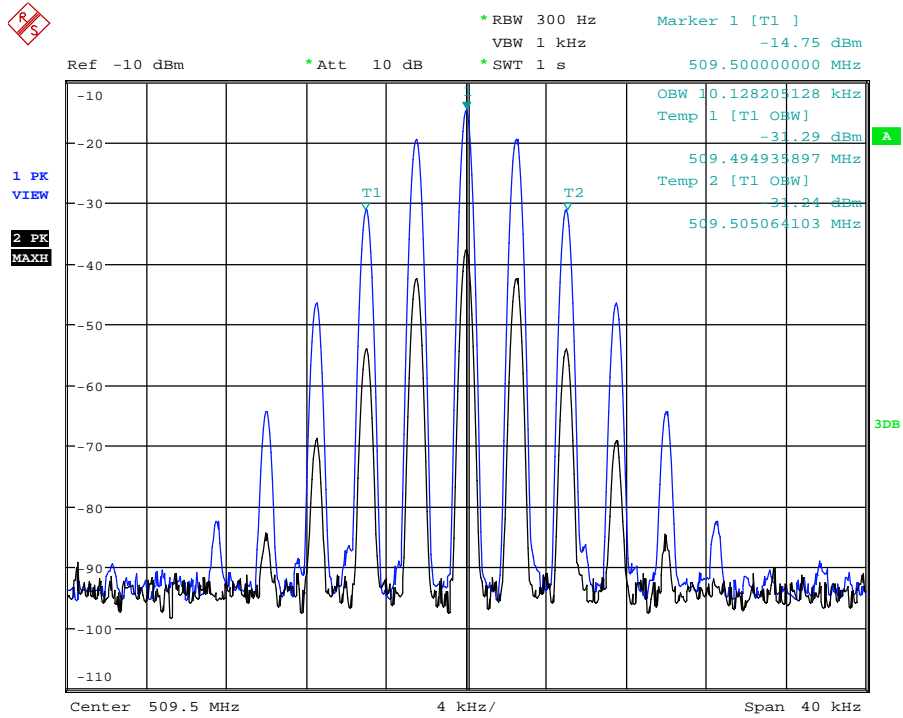

Date: 23.MAY.2011 13:20:03

510 MHz Signal Generator with deviation set to 2.5 kHz FM

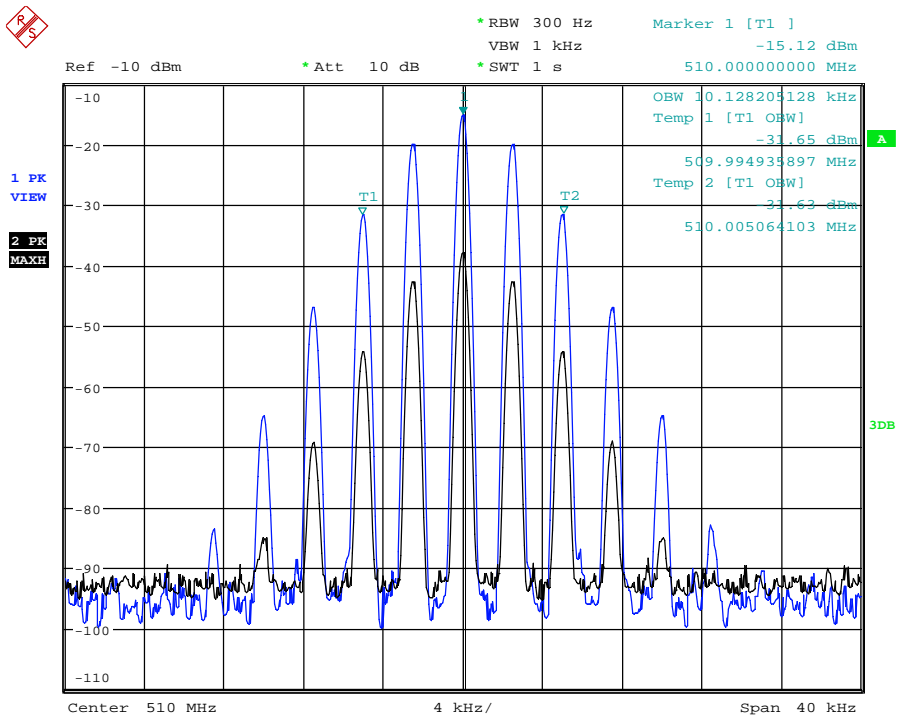

Date: 23.MAY.2011 13:21:58

TRANSMITTER TESTS

AMPLIFIER SPURIOUS EMISSIONS – CONDUCTED – Part 2.1053 – UHF UPLINK

Ambient temperature = 22°C
 Relative humidity = 42%
 Supply voltage = +110Vac

Radio Laboratory
 Test Signal = F3E

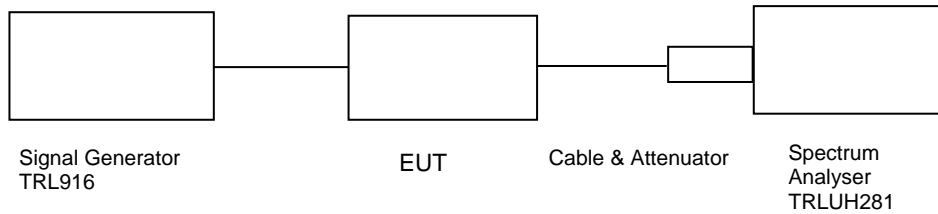

The test was set up as per the diagram. The level at the input was adjusted to compensate for the loss of the interconnecting cable. The unit was tested operating at maximum power and on three test frequencies.

The Spurious limit was calculated as follows:

On any frequency removed from the assigned frequency by more that 250% of the authorised bandwidth

At least $43 + 10 \log P$ dB

$(10 \log P_{\text{watts}}) - (43 + 10 \log (P_{\text{watts}} * 1000)) = \text{Limit} = -13 \text{ dBm}$

RESULTS

Frequency Range	Frequency (MHz)	Measured Level (dBm)	Attenuator & Cable Losses (dB)	Emission Level (dBm)	Limit (dBm)
100 kHz – 5.2 GHz	No Significant Emissions Within 20dB of Limit				-13

The test equipment used for the Transmitter Conducted Emissions:

Type of Equipment	Maker/ Supplier	Model No.	Serial No.	TRL No.	Actual Equipment Used
Spectrum Analyser	Rohde & Schwarz	FSU46	200034	UH281	X
Attenuator	Bird	8308-200-N	N/A	103	X
Attenuator	Bird	8304-100-N	N/A	222	X
Cable	TRL	N/A	N/A	UH271	X
Cable	TRL	N/A	N/A	UH272	X
Cable	TRL	N/A	N/A	UH273	X
Signal Generator	Rohde & Schwarz	Vector Signal Generator	255812	916	X

509.5 MHz Channel Conducted Spurious Emissions from 30 MHz to 1 GHz

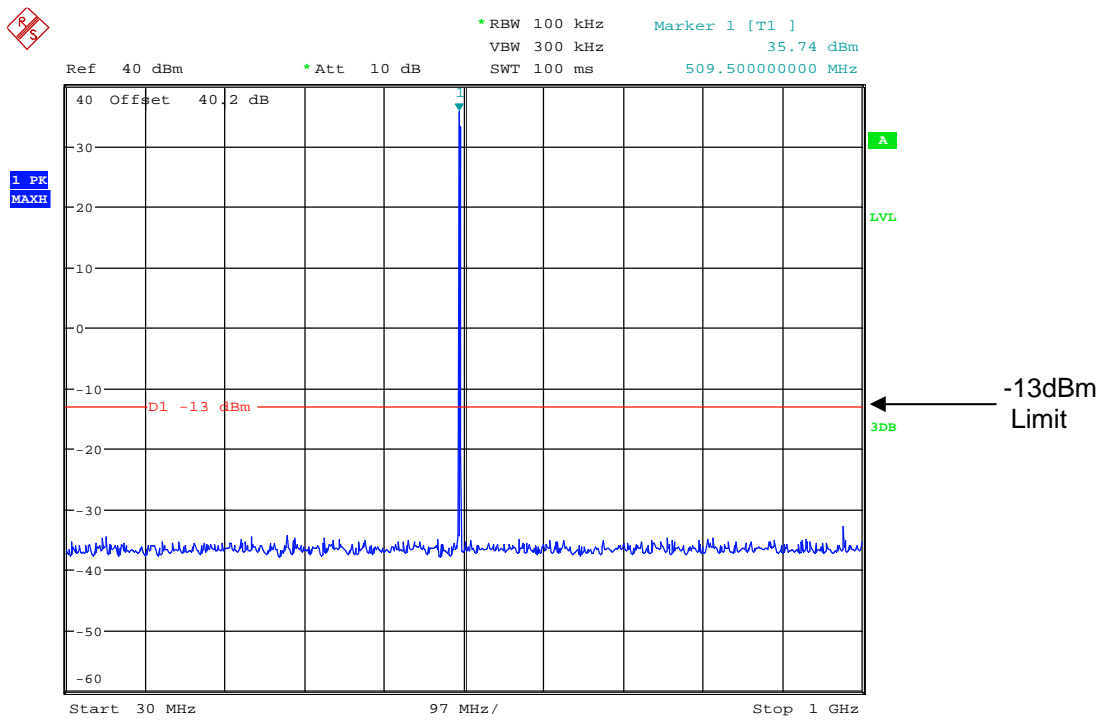

Date: 23.MAY.2011 10:54:11

509.5 MHz Channel Conducted Spurious Emissions from 1 GHz to 3 GHz

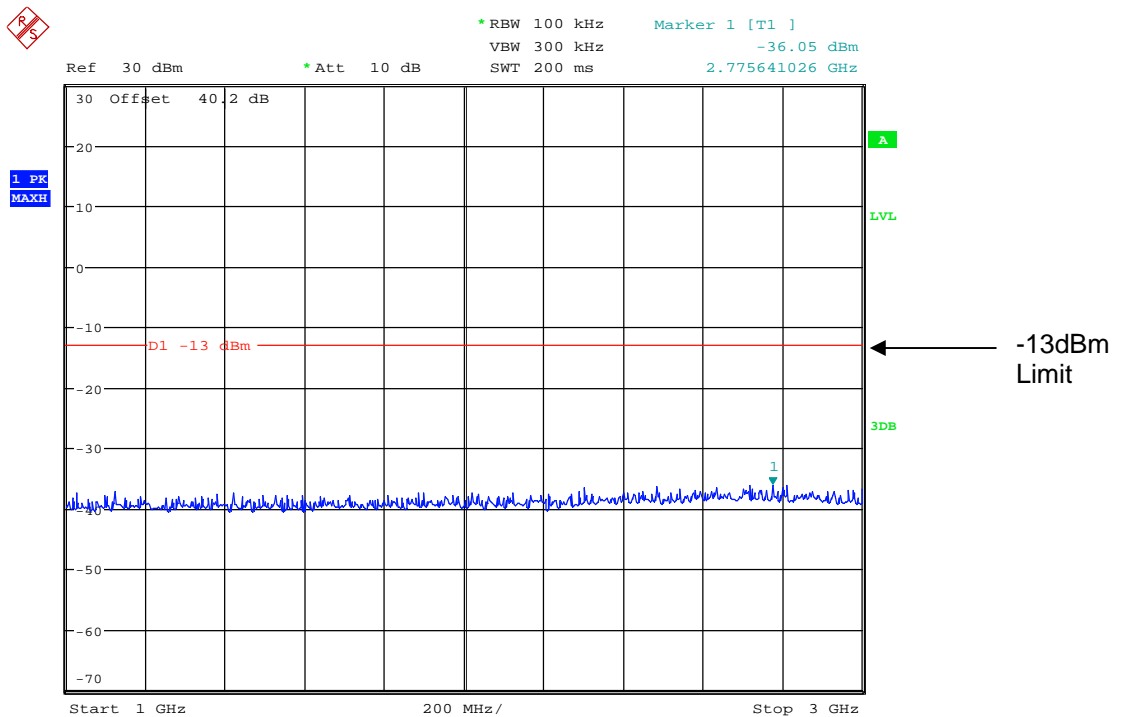

Date: 23.MAY.2011 10:54:37

509.5 MHz Channel Conducted Spurious Emissions from 3 GHz to 5.2 GHz

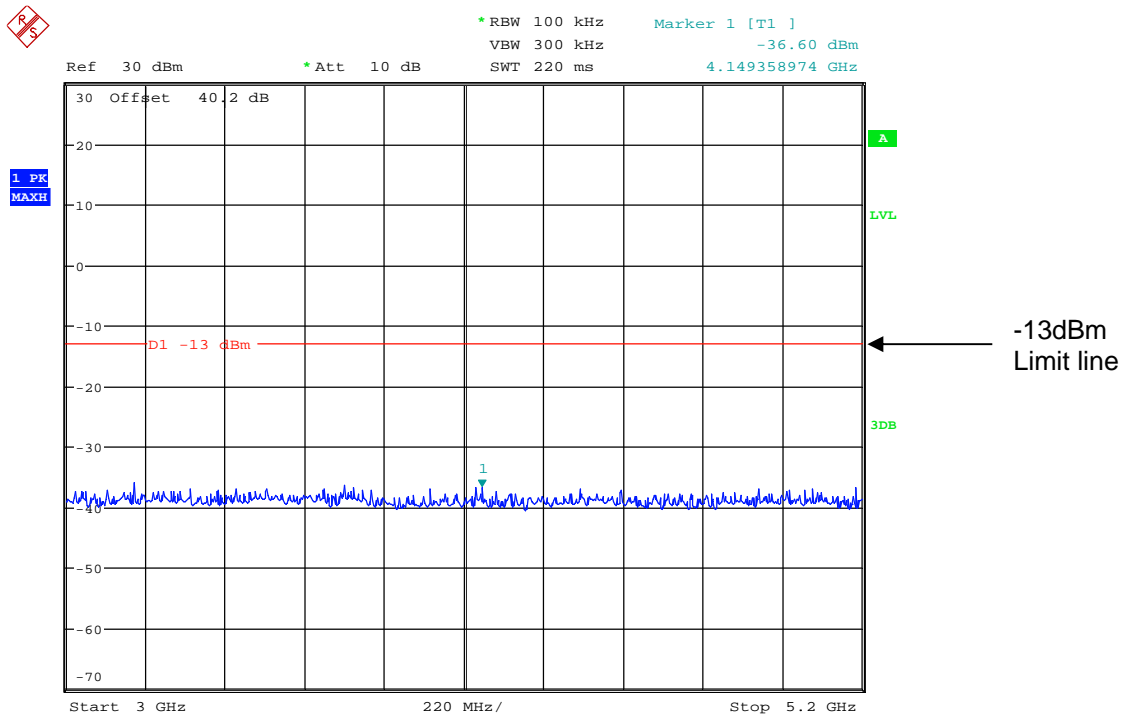

Date: 23.MAY.2011 10:54:56

510 MHz Channel Conducted Spurious Emissions from 30 MHz to 1 GHz

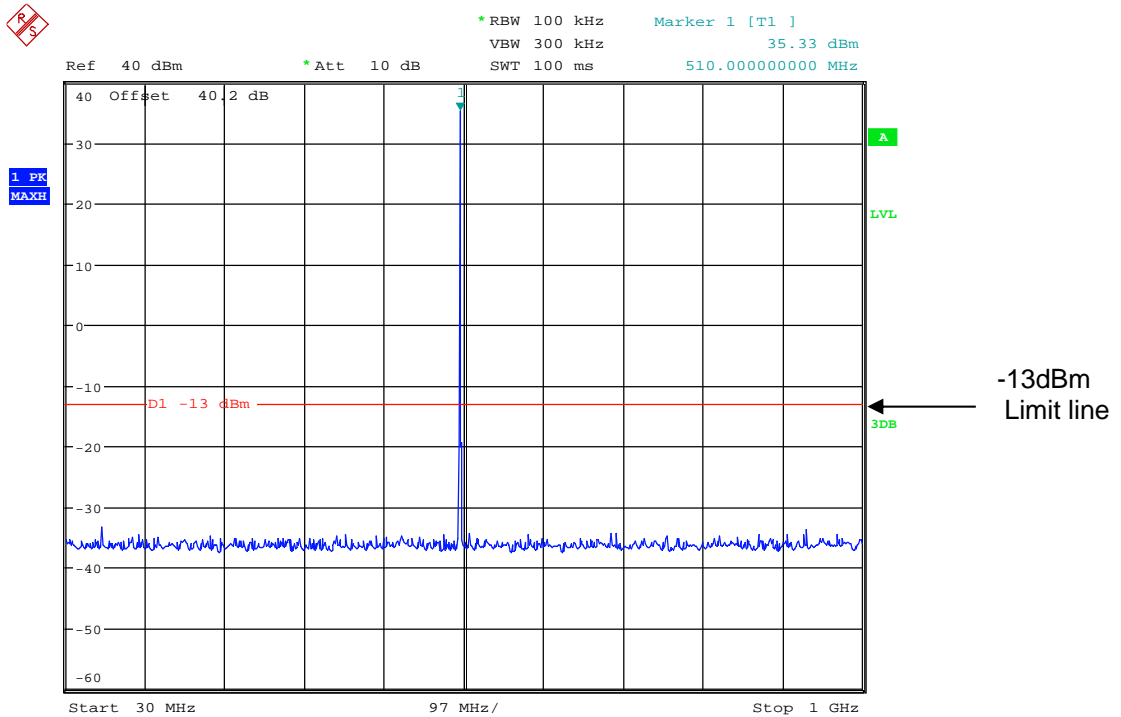

Date: 23.MAY.2011 10:53:50

510 MHz Channel Conducted Spurious Emissions from 1 GHz to 3 GHz

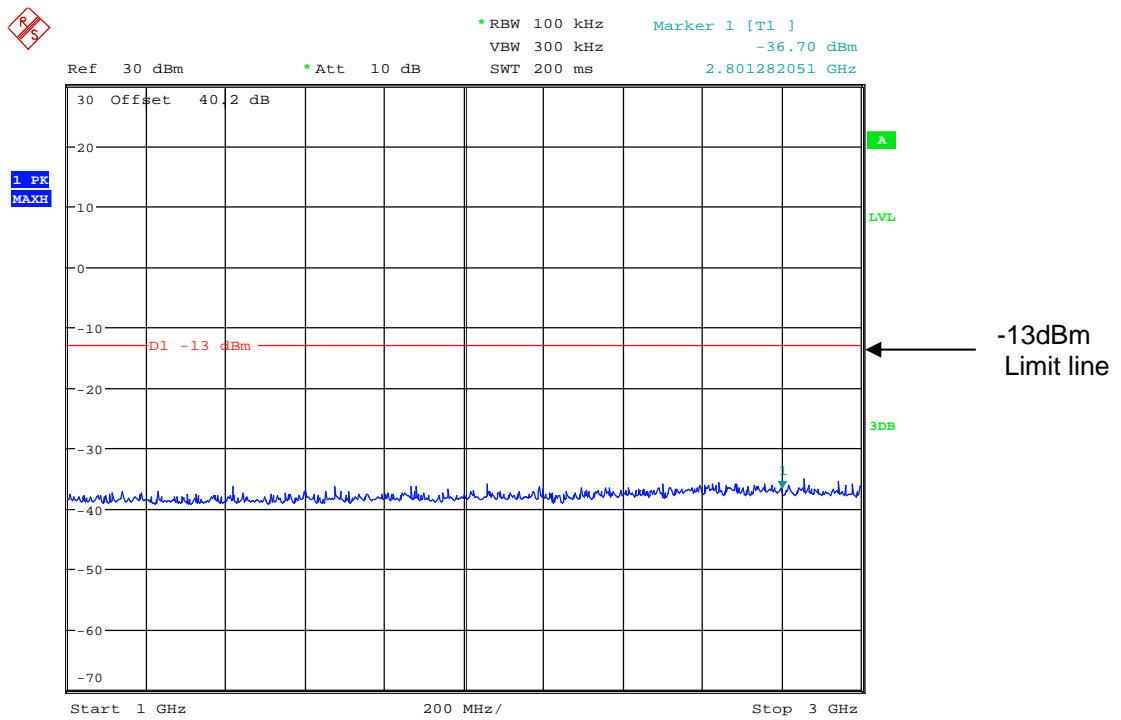

Date: 23.MAY.2011 10:52:55

510 MHz Channel Conducted Spurious Emissions from 3 GHz to 5.2 GHz

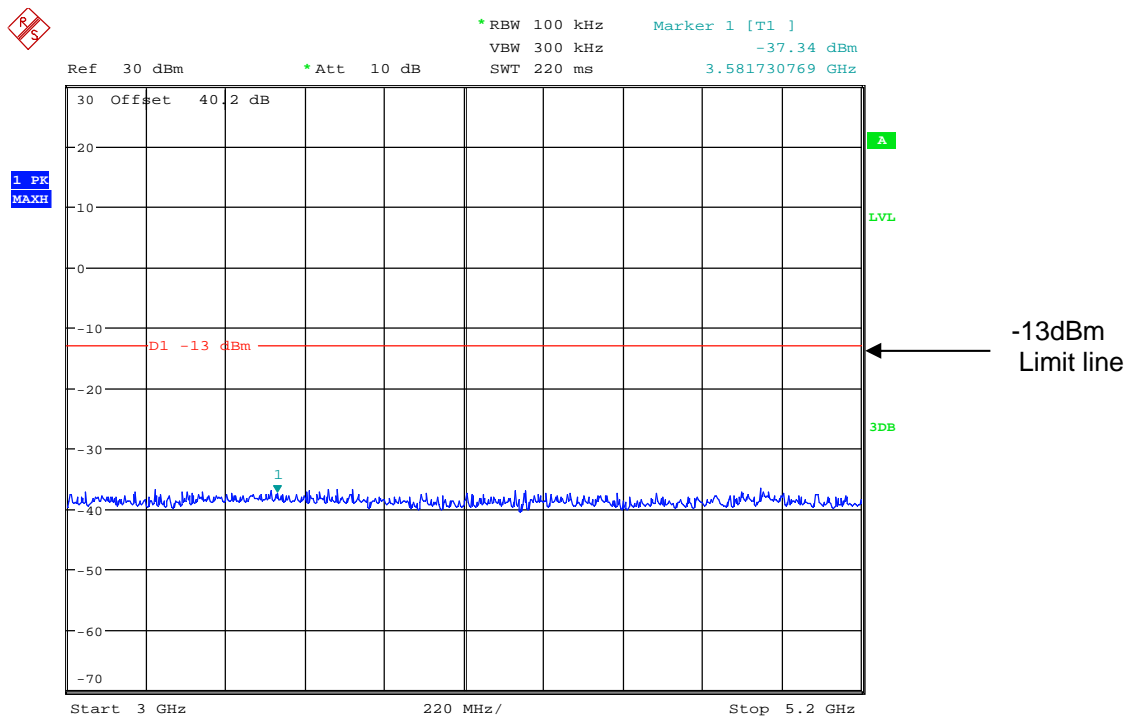

Date: 23.MAY.2011 10:53:29

510.5 MHz Channel Conducted Spurious Emissions from 3 GHz to 5.2 GHz

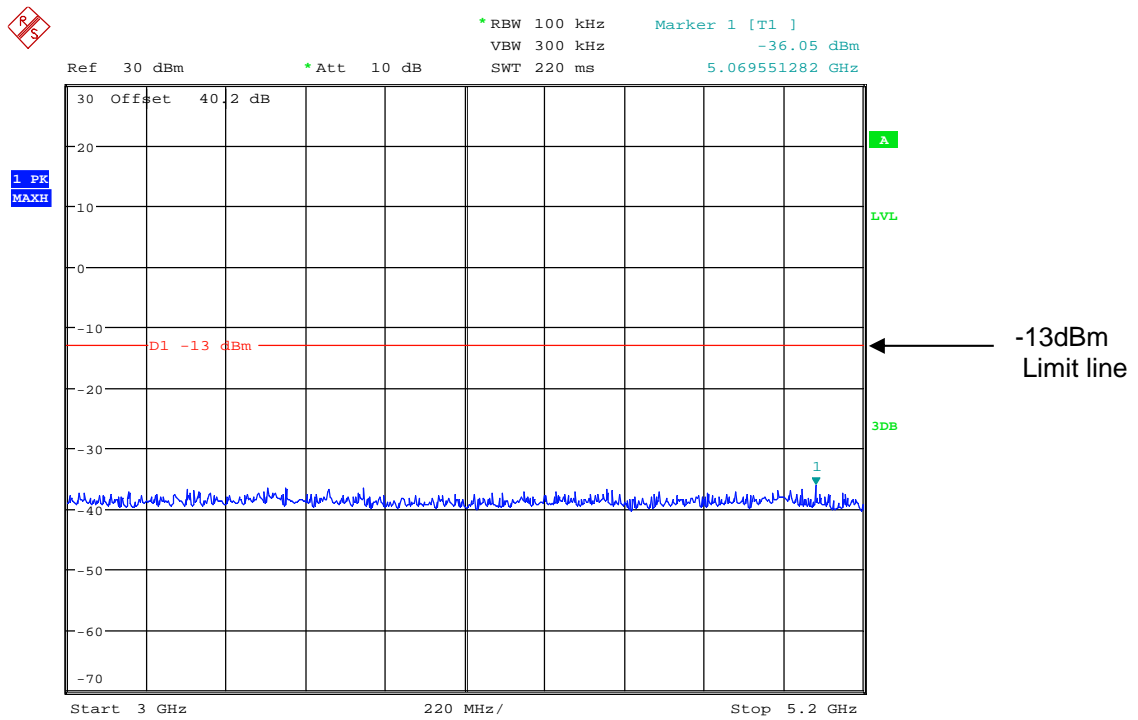

Date: 23.MAY.2011 10:55:19

AMPLIFIER SPURIOUS EMISSIONS – RADIATED – Part 2.1053– UHF UPLINK

Ambient temperature = 22°C
 Relative humidity = 46.2%
 Conditions = OATS
 Supply voltage = +110Vac
 Supply Frequency = N/A

Test Signal = F3E

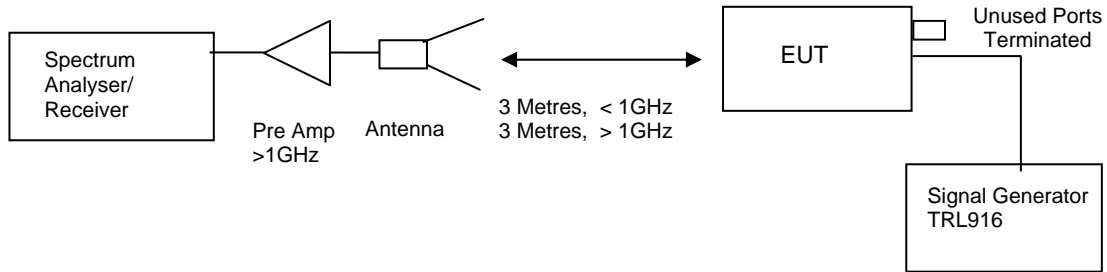

The test was set up as per the diagram. The level at the input was adjusted to compensate for the loss of the interconnecting cable. The unit was tested operating maximum power on three test frequencies with a 50 ohm load on the output. The unit was also tested with the signal generator replaced by another 50ohm load.

The Spurious limit was calculated as follows:

On any frequency removed from the assigned frequency by more that 250% of the authorised bandwidth

At least 43 + 10 log PdB

$$(10\log P_{\text{watts}}) - (43+10\log (P_{\text{watts}} * 1000)) = \text{LIMIT} = -13 \text{ dBm}$$

RESULTS

Frequency Range	Frequency (MHz)	Meas. Rx. (dBµV)	Cable Loss (dB)	Antenna Factor	Field Strength (dBµV/m)	Calculated EIRP (dBm)	Limit (dBm)
30 MHz – 5.2 GHz	No Significant Emissions Within 20dB of Limit.						-13

The test equipment used for the Transmitter Spurious Emissions:

Type Of Equipment	Maker/ Supplier	Model No.	Serial No.	TRL No.	Actual Equipment Used
Horn	Emco	3115	9010-3580	138	X
Spectrum Analyser	Rohde &Schwarz	FSU46	200034	UH281	X
Pre Amplifier	Hp	8449B	3008A016	572	X
Signal Generator	Marconi	2042	119388/080	176	X
Antenna	York	CBL611/A	1618	UH191	X
Receiver	Rohde &Schwarz	ESVS10	825892/006	UH04	X

509.5 MHz Channel Radiated Spurious Emissions from 30 MHz to 1 GHz

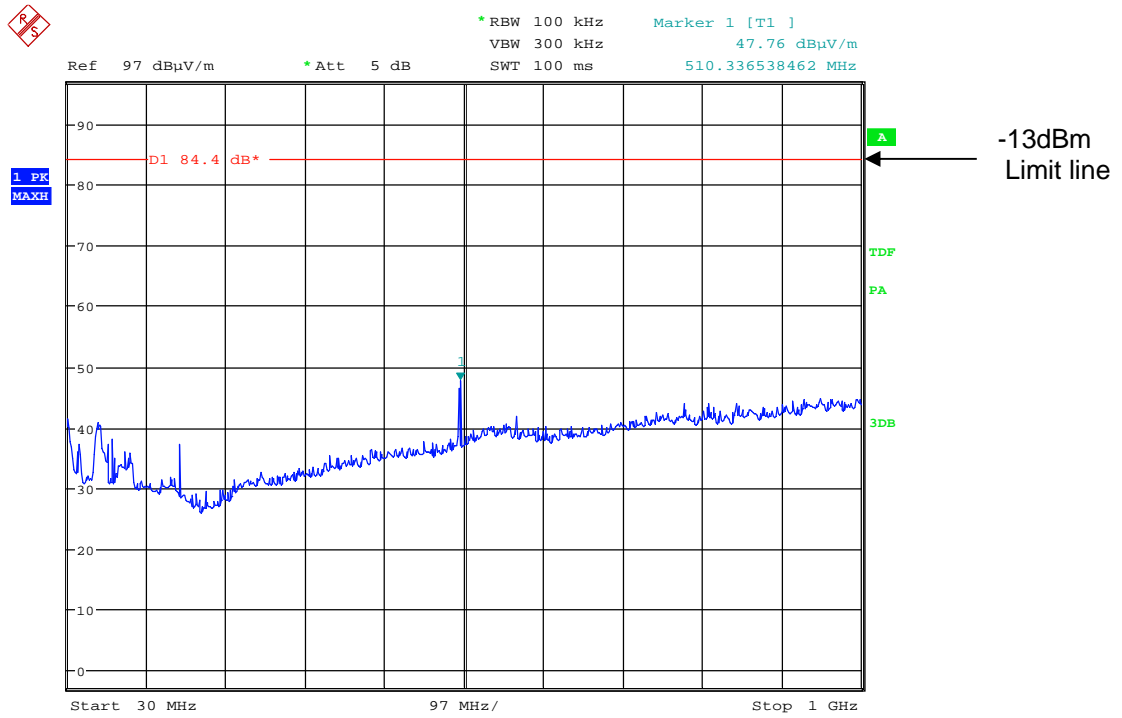

Date: 20.MAY.2011 10:36:07

509.5 MHz Channel Radiated Spurious Emissions from 1 GHz to 3 GHz

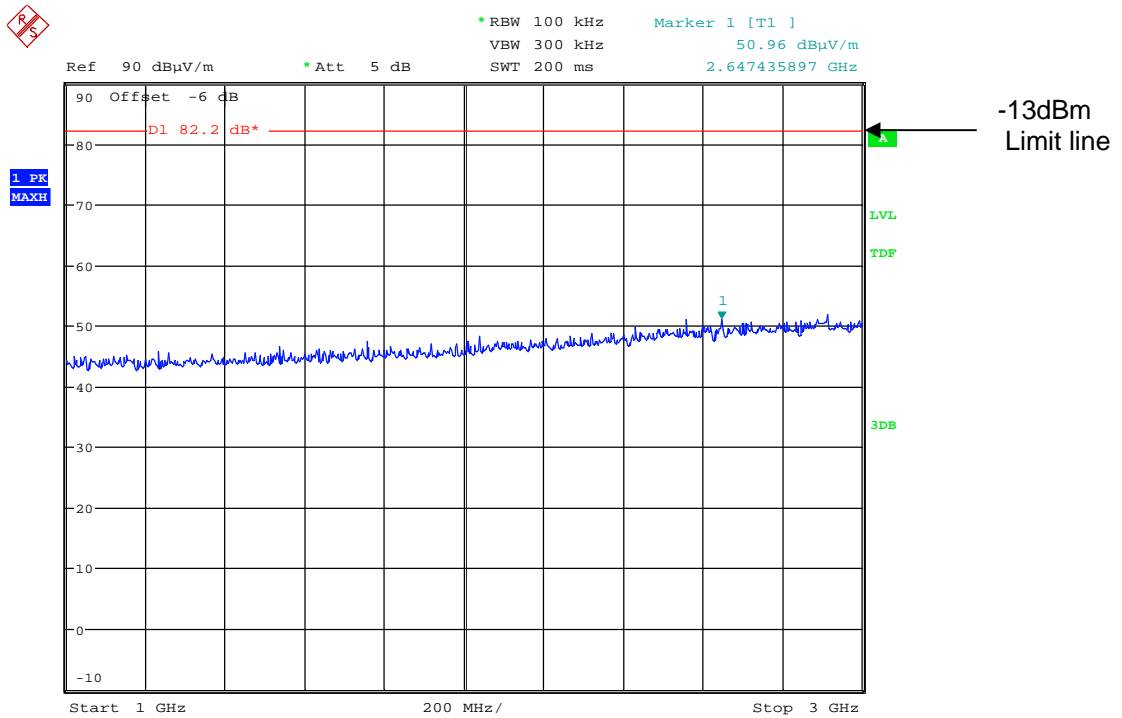

Date: 20.MAY.2011 09:49:01

509.5 MHz Channel Radiated Spurious Emissions from 3 GHz to 5.2 GHz

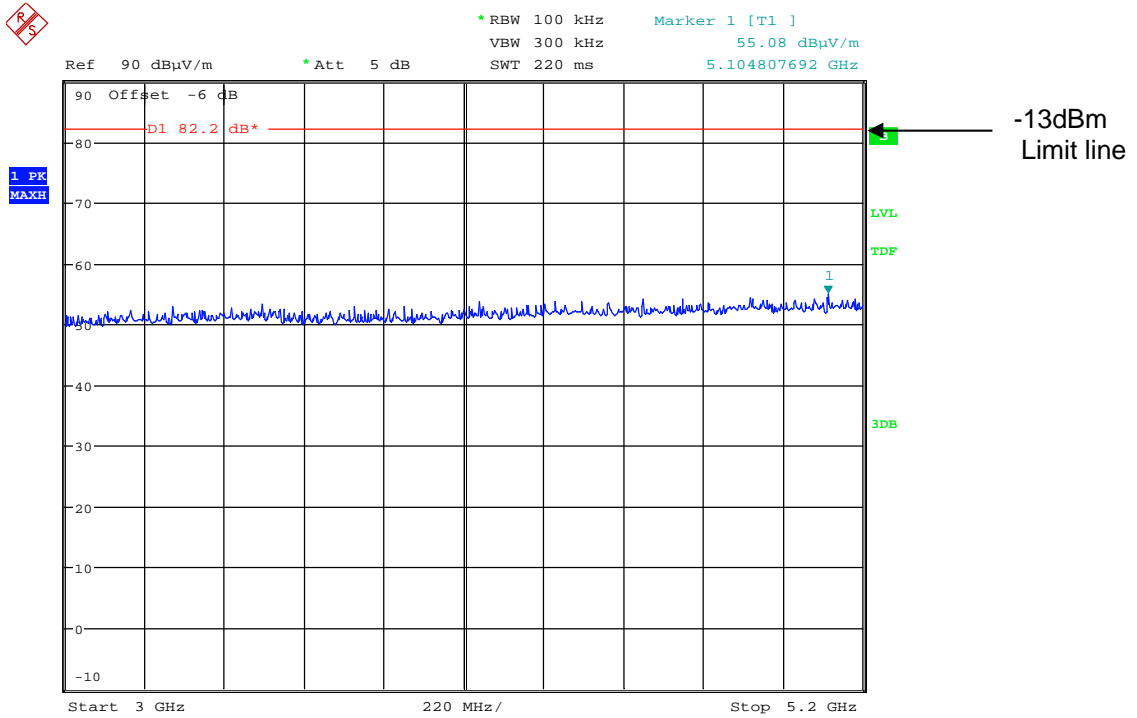

Date: 20.MAY.2011 09:48:47

510 MHz Channel Radiated Spurious Emissions from 30 MHz to 1 GHz

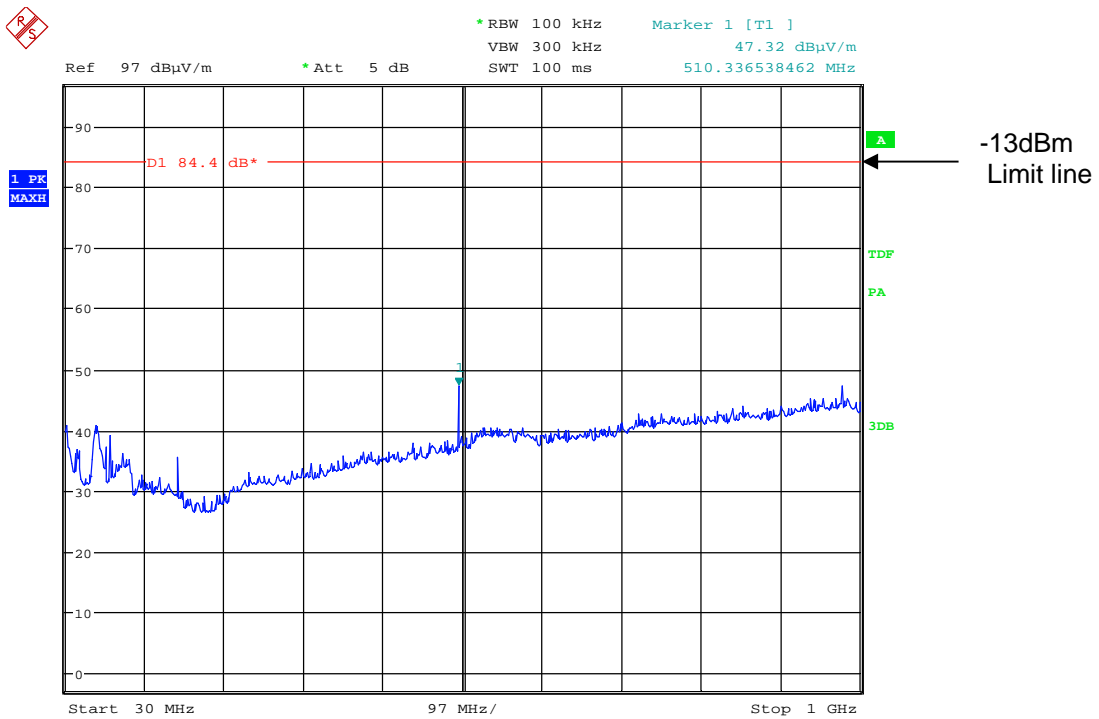

Date: 20.MAY.2011 10:35:50

510 MHz Channel Radiated Spurious Emissions from 1 GHz to 3 GHz

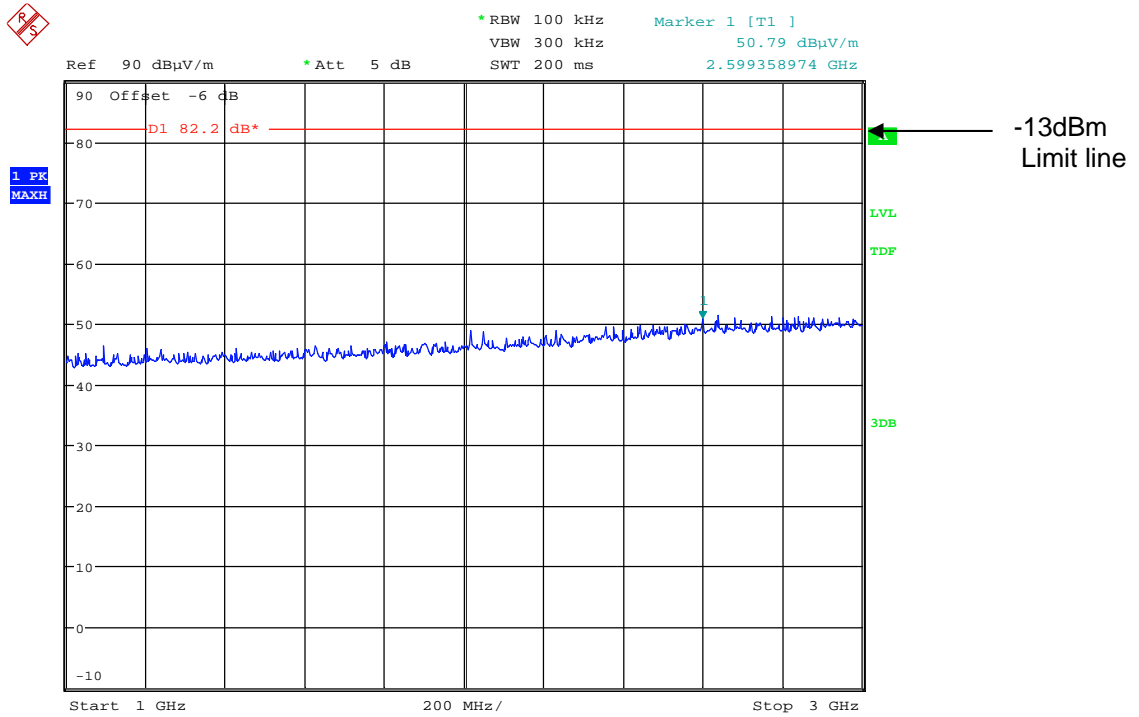

Date: 20.MAY.2011 09:48:02

510 MHz Channel Radiated Spurious Emissions from 3 GHz to 5.2 GHz

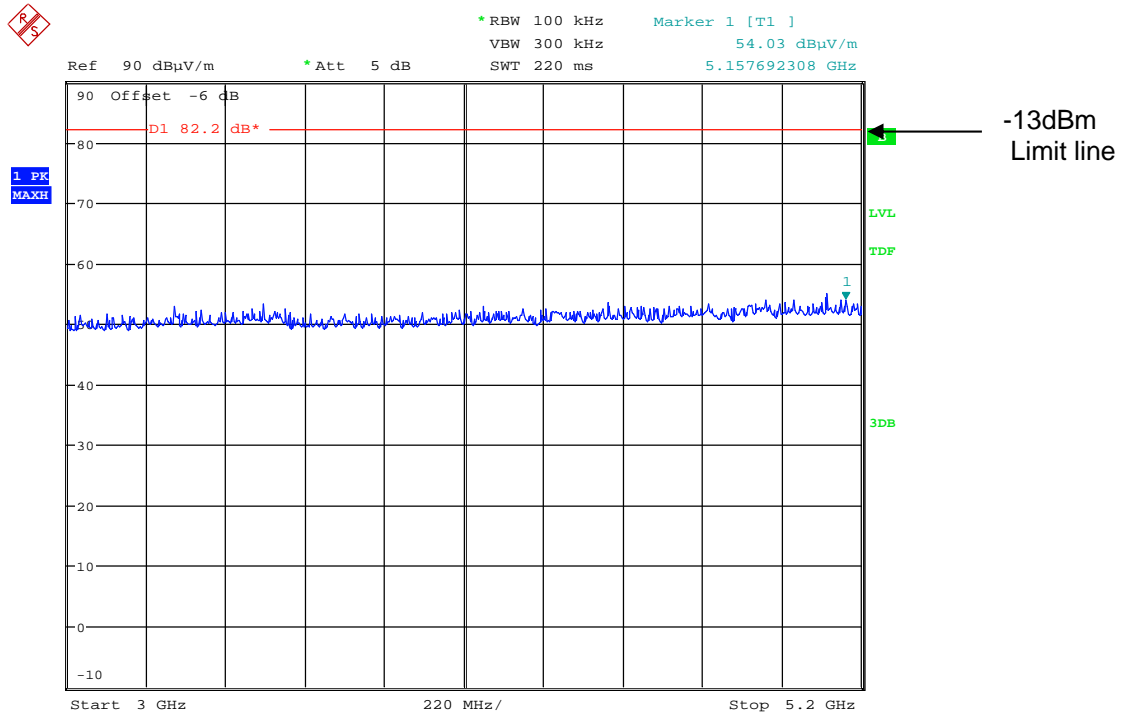

Date: 20.MAY.2011 09:48:18

510.5 MHz Channel Radiated Spurious Emissions from 30 MHz to 1 GHz

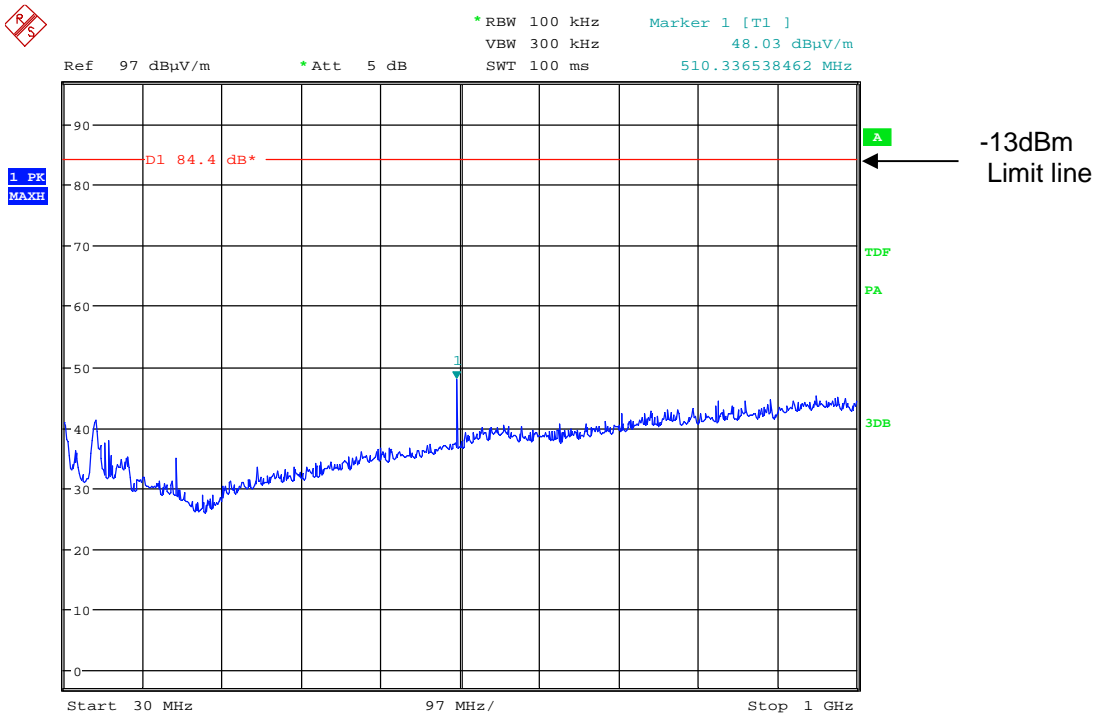

Date: 20.MAY.2011 10:35:26

510.5 MHz Channel Radiated Spurious Emissions from 1 GHz to 3 GHz

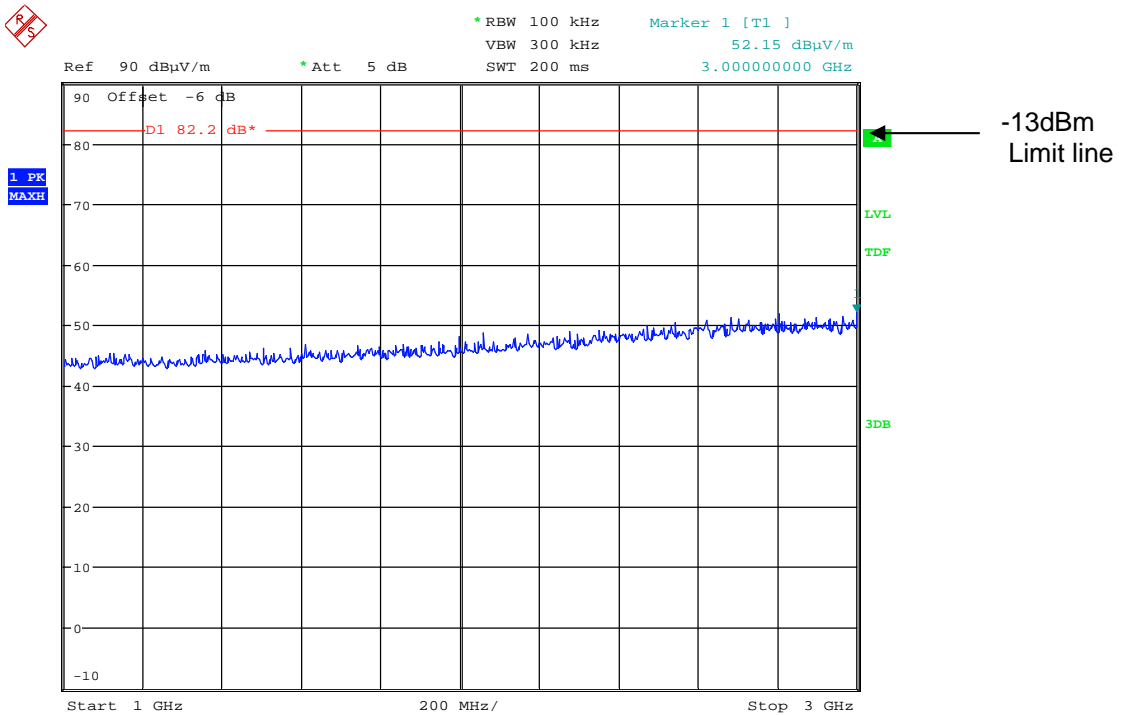

Date: 20.MAY.2011 09:47:41

510.5 MHz Channel Radiated Spurious Emissions from 3 GHz to 5.2 GHz

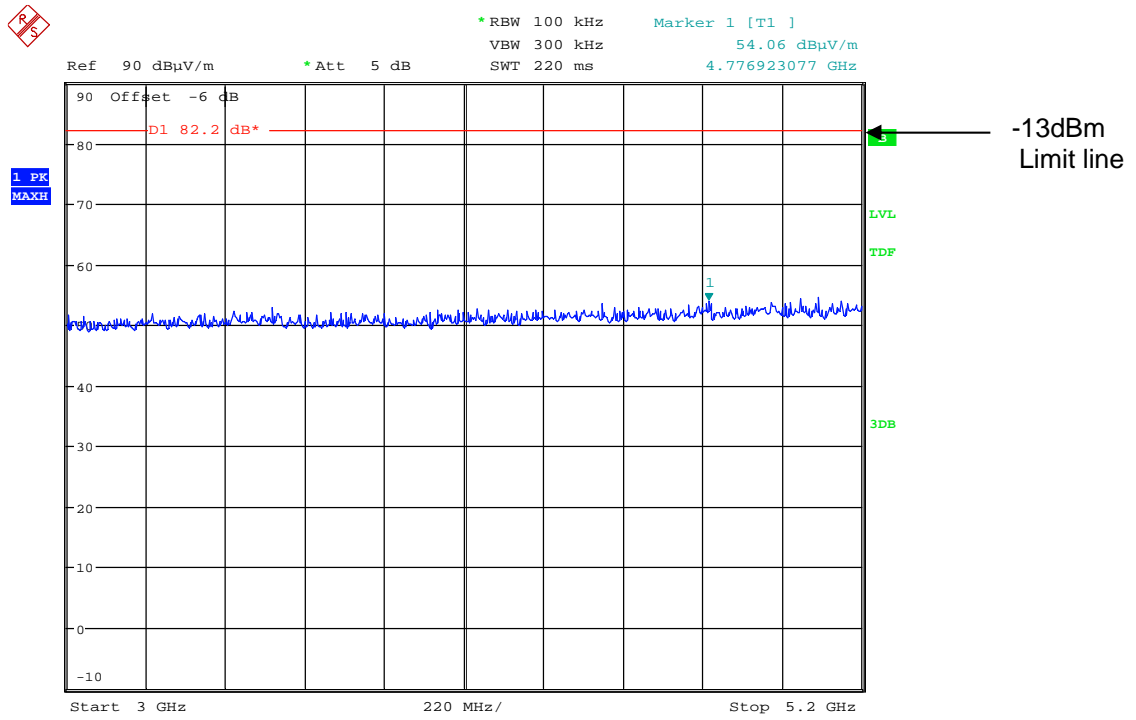

Date: 20.MAY.2011 09:47:21

ANNEX A
PHOTOGRAPHS

Photograph 1: 30 MHz to 1 GHz Test Setup



Photograph 2: Above 1 GHz Test Setup



Photograph 3: EUT Close Up



ANNEX B
APPLICANT'S SUBMISSION OF DOCUMENTATION LIST

APPLICANT'S SUBMISSION OF DOCUMENTATION LIST

a.	TCB	-	APPLICATION	[X]
		-	FEE	[X]
b.	AGENT'S LETTER OF AUTHORISATION	-		[X]
c.	MODEL(s) vs IDENTITY	-		[]
d.	ALTERNATIVE TRADE NAME DECLARATION(s)	-		[]
e.	LABELLING	-	PHOTOGRAPHS	[]
		-	DECLARATION	[]
		-	DRAWINGS	[]
f.	TECHNICAL DESCRIPTION	-		[X]
g.	BLOCK DIAGRAMS	-	Tx	[X]
		-	Rx	[]
		-	PSU	[]
		-	AUX	[]
h.	CIRCUIT DIAGRAMS	-	Tx	[X]
		-	Rx	[]
		-	PSU	[]
		-	AUX	[]
i.	COMPONENT LOCATION	-	Tx	[]
		-	Rx	[]
		-	PSU	[]
		-	AUX	[]
j.	PCB TRACK LAYOUT	-	Tx	[]
		-	Rx	[]
		-	PSU	[]
		-	AUX	[]
k.	BILL OF MATERIALS	-	Tx	[X]
		-	Rx	[]
		-	PSU	[]
		-	AUX	[]
l.	USER INSTALLATION / OPERATING INSTRUCTIONS	-		[X]

ANNEX C
EQUIPMENT CALIBRATION

Reference Number	Equipment Type	Manufacturer	Last Calibration	Calibration Period	Due For Calibration
UH003	Receiver	R&S	13/01/2011	12	13/01/2012
UH004	Receiver	R&S	14/12/2010	12	14/12/2011
UH06/07	IC OATS Submission	TRL	02/07/2009	24	02/07/2011
UH06/07	NSA Calibration	TRL	24/06/2010	12	24/06/2011
UH093	Bilog	Chase	03/06/2009	24	03/06/2011
UH191	Bilog	Chase	08/11/2010	24	08/11/2012
UH253	1m Cable N type	TRL	01/03/2011	12	01/03/2012
UH254	1m Cable N type	TRL	01/03/2011	12	01/03/2012
UH269	1m Cable N type	TRL	01/03/2011	12	01/03/2012
UH270	1m Cable N type	TRL	01/03/2011	12	01/03/2012
UH271	1.5m Cable N type	TRL	01/03/2011	12	01/03/2012
UH272	1.5m Cable N type	TRL	01/03/2011	12	01/03/2012
UH273	2m Cable N type	TRL	01/03/2011	12	01/03/2012
UH274	2m Cable N type	TRL	01/03/2011	12	01/03/2012
UH281	Spectrum Analyser	R&S	10/02/2011	12	10/02/2012
UH288	1m Cable N type	N/A	01/03/2011	12	01/03/2012
UH293	K-Type Cable	Megaphase	24/11/2010	12	24/11/2011
UH372	PreAmp	Wat-John	14/04/2010	12	14/04/2011
UH377	ESU 26	R&S	11/06/2010	13	11/07/2011
UH378	3M Cable	TRaC	01/03/2011	12	01/03/2012
UH387	Chamber 1	Rainford EMC	26/06/2010	12	26/06/2011
UH388	Chamber 2	Rainford EMC	23/06/2010	12	23/06/2011
L138	1-18GHz Horn	EMCO	10/09/2009	24	10/09/2011
L139	1-18GHz Horn	EMCO	17/08/2009	24	17/08/2011
L176	Signal Generator	Marconi	08/07/2010	12	08/07/2011
L254	Signal Generator	Marconi	15/09/2010	12	15/09/2011
L572	Pre Amp	Agilent	24/11/2010	12	24/11/2011
L664	3M Cable	TRaC	01/03/2011	12	01/03/2012
REF910	Spectrum Analyser	R&S	27/10/2010	12	27/10/2011
TRL170	Combiner	Elcom		Calibrate in use	

ANNEX D
MEASUREMENT UNCERTAINTY

Radio Testing – General Uncertainty Schedule

All statements of uncertainty are expanded standard uncertainty using a coverage factor of 1.96 to give a 95% confidence where no required test level exists.

[1] Adjacent Channel Power

Uncertainty in test result = **1.86dB**

[2] Carrier Power

Uncertainty in test result (Equipment - TRLUH120) = **2.18dB**

Uncertainty in test result (Equipment – TRL05) = **1.08dB**

Uncertainty in test result (Equipment – TRL479) = **2.48dB**

[3] Effective Radiated Power

Uncertainty in test result = **4.71dB**

[4] Spurious Emissions

Uncertainty in test result = **4.75dB**

[5] Maximum frequency error

Uncertainty in test result (Equipment - TRLUH120) = **119ppm**

Uncertainty in test result (Equipment – TRL05) = **0.113ppm**

Uncertainty in test result (Equipment – TRL479) = **0.265ppm**

[6] Radiated Emissions, field strength OATS 14kHz-18GHz Electric Field

Uncertainty in test result (14kHz – 30MHz) = **4.8dB**, Uncertainty in test result (30MHz – 1GHz) = **4.6dB**,

Uncertainty in test result (1GHz-18GHz) = **4.7dB**

[7] Frequency deviation

Uncertainty in test result = **3.2%**

[8] Magnetic Field Emissions

Uncertainty in test result = **2.3dB**

[9] Conducted Spurious

Uncertainty in test result (Equipment TRL479) Up to 8.1GHz = **3.31dB**

Uncertainty in test result (Equipment TRL479) 8.1GHz – 15.3GHz = **4.43dB**

Uncertainty in test result (Equipment TRL479) 15.3GHz – 21GHz = **5.34dB**

Uncertainty in test result (Equipment TRLUH120) Up to 26GHz = **3.14dB**

[10] Channel Bandwidth

Uncertainty in test result = **15.5%**

[11] Amplitude and Time Measurement – Oscilloscope

Uncertainty in overall test level = **2.1dB**, Uncertainty in time measurement = **0.59%**, Uncertainty in Amplitude measurement = **0.82%**

[11] Power Line Conduction

Uncertainty in test result = **3.4dB**

[12] Spectrum Mask Measurements

Uncertainty in test result = **2.59% (frequency)**
Uncertainty in test result = **1.32dB (amplitude)**

[13] Adjacent Sub Band Selectivity

Uncertainty in test result = **1.24dB**

[14] Receiver Blocking – Listen Mode, Radiated

Uncertainty in test result = **3.42dB**

[15] Receiver Blocking – Talk Mode, Radiated

Uncertainty in test result = **3.36dB**

[16] Receiver Blocking – Talk Mode, Conducted

Uncertainty in test result = **1.24dB**

[17] Receiver Threshold

Uncertainty in test result = **3.23dB**

[18] Transmission Time Measurement

Uncertainty in test result = **7.98%**

