



**TEST REPORT**

**FOR**

**AXELL WIRELESS**

**ON**

**EXPOSITION METRO LINE**  
**UHF LOW U/L FO BOOSTER AMPLIFIER**

**DOCUMENT NO. TTR-005045-WUS-03**

TEST REPORT NO: TTR-005045WUS-03  
COPY NO: 1  
ISSUE NO: 1  
FCC ID: NEO60-274601

**REPORT ON THE CERTIFICATION TESTING OF A  
AXELL WIRELESS  
EXPOSITION METRO LINE  
UHF LOW U/L FO BOOSTER AMPLIFIER  
WITH RESPECT TO  
THE FCC RULES CFR 47,  
PART 90**

**PRIVATE LAND MOBILE REPEATER.**

TEST DATE: 20<sup>th</sup> - 23<sup>rd</sup> May 2011

APPROVED BY: \_\_\_\_\_



J CHARTERS  
PRODUCT MANAGER

DATE: 6<sup>th</sup> June 2011

Distribution:

- Copy Nos:
1. Axell Wireless
  2. TRaC Global

THIS DOCUMENT MAY BE REPRODUCED ONLY IN ITS ENTIRETY AND WITHOUT CHANGE

## CONTENTS

	<b>PAGE</b>	
CERTIFICATE OF CONFORMITY & COMPLIANCE	4	
APPLICANT'S SUMMARY	5	
EQUIPMENT TEST CONDITIONS	6	
TESTS REQUIRED	6	
TEST RESULTS	7 – 31	
		<b>ANNEX</b>
PHOTOGRAPHS	A	
PHOTOGRAPH No. 1&2: Test setup		
PHOTOGRAPH No. 3: Equipment overview		
APPLICANT'S SUBMISSION OF DOCUMENTATION LIST	B	
EQUIPMENT CALIBRATION	C	
MEASUREMENT UNCERTAINTY	D	
 <b>Notes:</b>		
1. Component failure during test	YES	<input type="checkbox"/>
	NO	<input checked="" type="checkbox"/>
2. If Yes, details of failure:		
3. The facilities used for the testing of the product contain in this report are FCC Listed.		

**CERTIFICATE OF CONFORMITY & COMPLIANCE**

FCC IDENTITY: NEO60-274601

PURPOSE OF TEST: Certification

TEST SPECIFICATION: FCC RULES CFR 47, Part 90

TEST RESULT: Compliant to Specification

EQUIPMENT UNDER TEST: UHF Low U/L FO Booster Amplifier

EQUIPMENT TYPE: Private Land Mobile Repeater

MAXIMUM GAIN: Uplink(UHF) = 60.90 dB

MAXIMUM INPUT: Uplink (UHF) = - 27.0dBm

MAXIMUM OUTPUT CONDUCTED: Uplink (UHF) = +33.95dBm

CHANNEL BANDWIDTH: N/A Wideband amplifier

FREQUENCY GENERATION: N/A

MODULATION TYPE: F3E

POWER SOURCE(s): +110Vac

TEST DATE(s): 20<sup>th</sup> – 23<sup>rd</sup> May 2011

ORDER No(s): 72741

APPLICANT: Axell Wireless

ADDRESS: Aerial House  
Asheridge Road  
Chesham  
Buckinghamshire  
HP5 1TU

APPROVED BY:



J CHARTERS  
PRODUCT  
MANAGER

## APPLICANT'S SUMMARY

EQUIPMENT UNDER TEST (EUT): UHF Low U/L FO Booster Amplifier

EQUIPMENT TYPE: Private Land Mobile Repeater

PURPOSE OF TEST: Certification

TEST SPECIFICATION(s): FCC RULES CFR 47, Part 90

TEST RESULT: COMPLIANT Yes   
No

APPLICANT'S CATEGORY: MANUFACTURER   
IMPORTER   
DISTRIBUTOR   
TEST HOUSE   
AGENT

APPLICANT'S ORDER No(s): 72741

APPLICANT'S CONTACT PERSON(s): Mr Peter Bradfield

E-mail address: [peter.bradfield@axellwireless.com](mailto:peter.bradfield@axellwireless.com)

APPLICANT: Axell Wireless

ADDRESS: Aerial House  
Asheridge Road  
Chesham  
Buckinghamshire  
HP5 1TU  
United Kingdom

TEL: +44 (0)1494 777000

FAX: +44 (0)1494 778456

MANUFACTURER: Axell Wireless

EUT(s) COUNTRY OF ORIGIN: United Kingdom

TEST LABORATORY: TRaC Global

TEST DATE(s): 20<sup>th</sup> – 23<sup>rd</sup> May 2011

TEST REPORT No: TTR-005045WUS-03

## EQUIPMENT TEST / EXAMINATIONS REQUIRED

1.	TEST/EXAMINATION	RULE PART	APPLICABILITY	RESULT
	RF Power Output	90.205	Yes	Complies
	Audio Frequency Response	TIA EIA-603.3.2.6	N/A	N/A
	Audio Low-Pass Filter Response	TIA EIA-603.3.2.6	N/A	N/A
	Modulation Limiting	TIA EIA-603.3.2.6	N/A	N/A
	Occupied Bandwidth	90.210	Yes	Complies
	Spurious Emissions at Antenna Terminals	90.210	Yes	Complies
	Field Strength of Spurious Emissions	90.210	Yes	Complies
	Frequency Stability	90.213	N/A(note 1)	N/A
	Transient behaviour	90.214	N/A(note 2)	N/A

**Notes:**

- 1 The EUT does not contain modulation circuitry, therefore the test was not performed.
- 2 The EUT is not a keyed carrier system, therefore the test was not performed.

- 2. Product class: Uplink Class A  Class B   
Class A  Class B
  - 3. Product Use: Private Land Mobile Repeater
  - 4. Emission Designator: F3E
  - 5. Temperatures: Ambient (Tnom) 24°C
  - 6. Supply Voltages: Vnom +110Vac
- Note: Vnom voltages are as stated above unless otherwise shown on the test report page
- 7. Equipment Category: Single channel   
Two channel   
Multi-channel
  - 8. Channel spacing: Narrowband Uplink
  - 9. Test Location TRaC Global  
Skelmersdale
  - 10. Modifications made during test program No modifications were performed.

**System description:**

The UHF U/L FO Booster Amplifier system consists of a UHF uplink wideband amplifier. The uplink is a wideband amplifier and operates over the frequency band. 465.00MHz-466.00MHz

## COMPLIANCE TESTS

### AMPLIFIER GAIN – CONDUCTED – PART 2.1046 –UHF UPLINK

Ambient temperature = 24°C  
 Relative humidity = 50%  
 Supply voltage = +110Vac  
 Channel number = See test results

Radio Laboratory

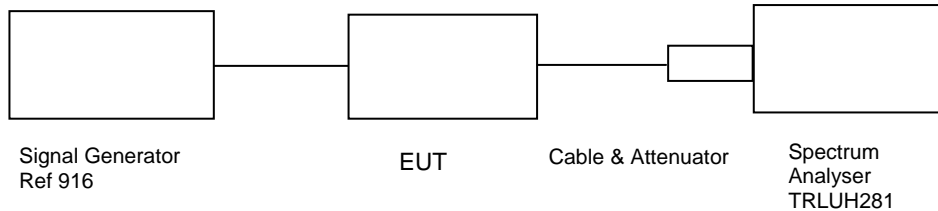

Frequency MHz	Signal Generator input level dBm	Input Cable Loss dB	Output Cable & Attenuator loss dB	Level at Spectrum Analyser dBm	Gain dB	Conducted Output Power dBm	Gain after 10dB input level increase dB
465.000	-27.50	0.10	40.10	-6.80	60.90	33.30	50.89
465.500	-27.00	0.10	40.10	-6.15	61.05	33.95	51.07
466.000	-27.20	0.10	40.10	-6.59	60.81	33.51	50.81

Notes: 1.The signal generator input was increased by 10dBs and the level of the output signal remeasured.

TYPE OF EQUIPMENT	MAKER/ SUPPLIER	MODEL No	SERIAL No	TRL No	ACTUAL EQUIPMENT USED
SPECTRUM ANALYSER	RHODE & SCHWARZ	FSU46	200034	UH281	X
ATTENUATOR	BIRD	8308-200-N	N/A	103	X
ATTENUATOR	BIRD	8304-100-N	N/A	222	X
CABLE	TRL	N/A	N/A	UH271	X
CABLE	TRL	N/A	N/A	UH272	X
CABLE	TRL	N/A	N/A	UH273	X
SIGNAL GENERATOR	RHODE & SCHWARZ	Vector Signal Generator	255812	916	X

## AMPLIFIER INTERMODULATION SPURIOUS EMISSIONS – CONDUCTED – PART 2.1053–UHF UPLINK

Ambient temperature = 24°C  
 Relative humidity = 50%  
 Supply voltage = +110Vac

Radio Laboratory

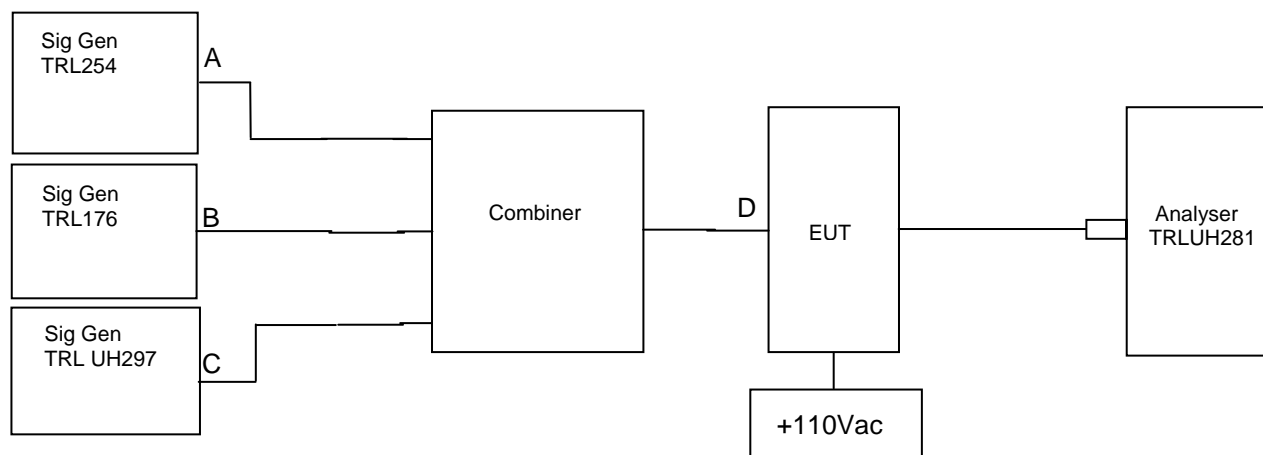

The intermodulation and spurious products were measured with the amplifier operating at maximum gain. A three tone test was conducted using the equipment as above. The input power level was adjusted so the level at point D was 10dB above the maximum input of -27dBm. The cable and attenuator loss between the EUT and the spectrum analyser was 40.10dB.

RF Input Frequency (MHz)			Highest Intermodulation Product Level (dBm)	Limit (dBm)
465.500	465.371	466.000	-16.17dBm@465.625MHz	-13

Sweep data is shown on the next page:

Test equipment used for intermodulation test

TYPE OF EQUIPMENT	MAKER/SUPPLIER	MODEL No	SERIAL No	TRL No	ACTUAL EQUIPMENT USED
SPECTRUM ANALYSER	R&S	FSU46	200034	UH281	X
SIGNAL GENERATOR	MARCONI	2042	119562/021	254	X
SIGNAL GENERATOR	R&S	SML 03	102268	UH297	X
SIGNAL GENERATOR	RHODE & SCHWARZ	Vector Signal Generator	255812	916	X
COMBINER	ELCOM	RC-4-50	N/A	170	X
CABLE	TRL	N/A	N/A	UH271	X
CABLE	TRL	N/A	N/A	UH272	X
CABLE	TRL	N/A	N/A	UH273	X
CABLE	TRL	N/A	N/A	UH269	X



# Intermodulation Close View

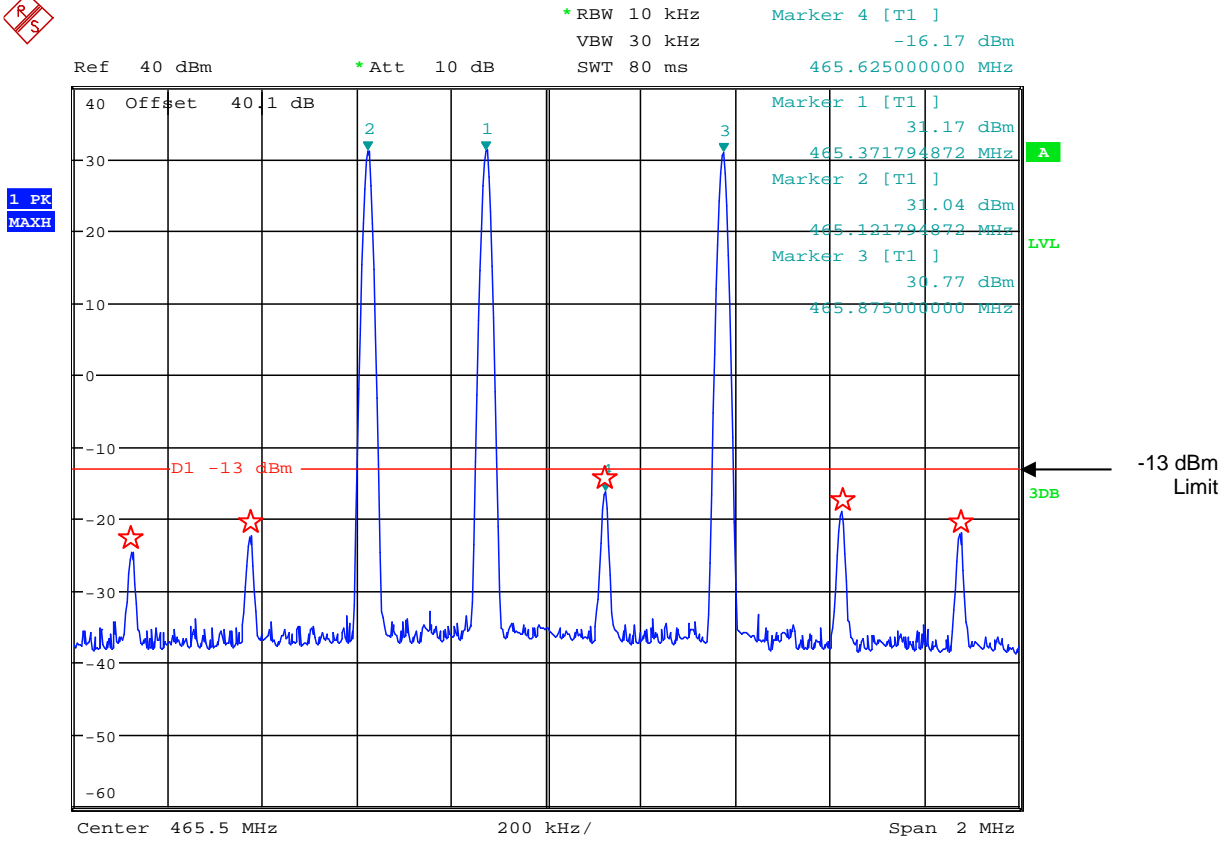

Date: 23.MAY.2011 11:25:27

# Intermodulation Wide View

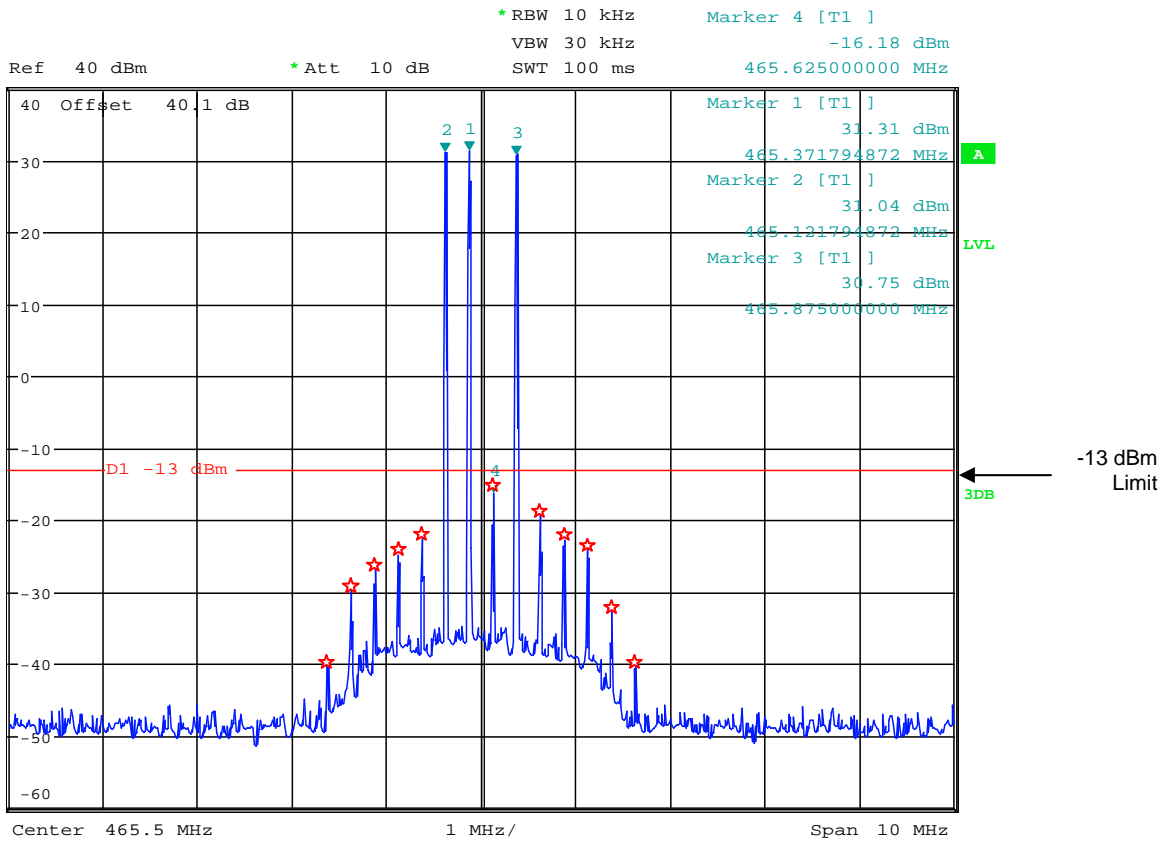

Date: 23.MAY.2011 11:25:34

The above plots show that all products (designated by ☆) are below the spurious limit.

30MHz – 1GHz

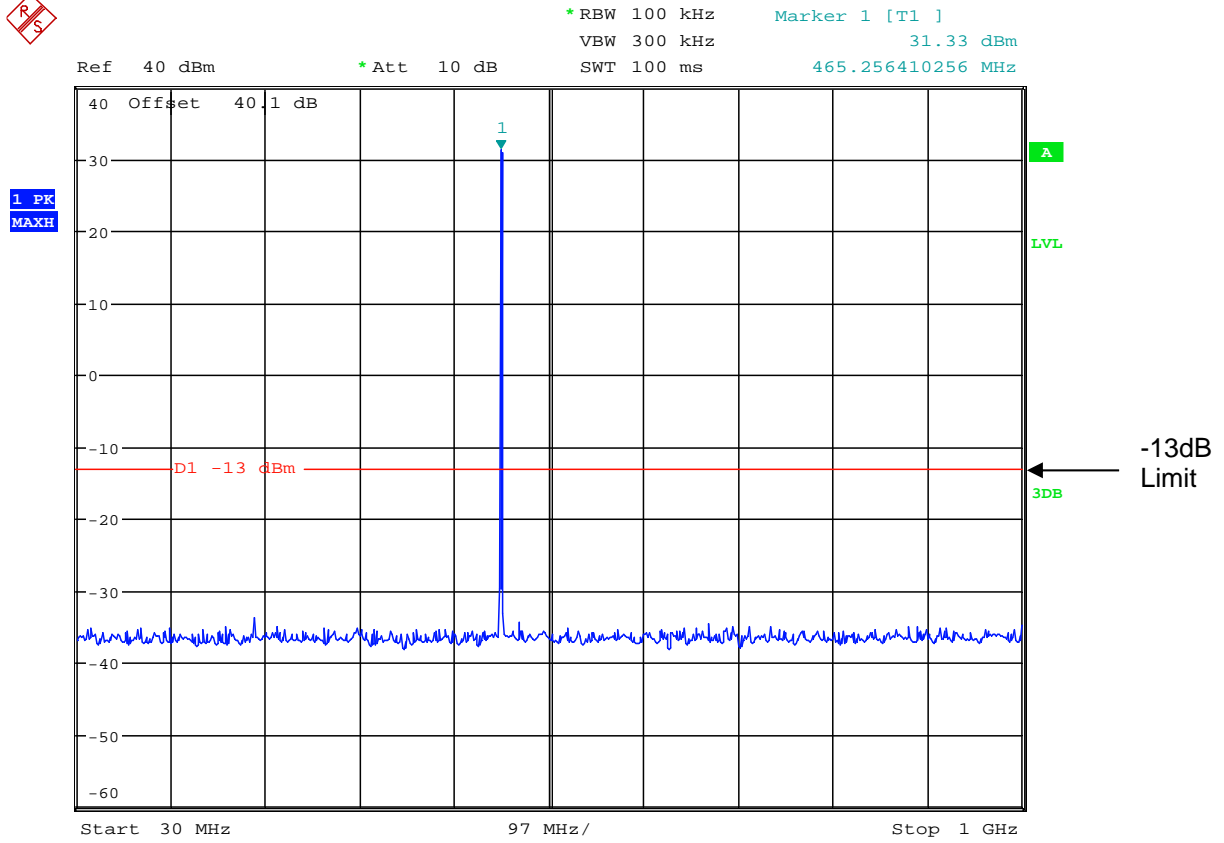

Date: 23.MAY.2011 11:24:45

1GHz -3GHz

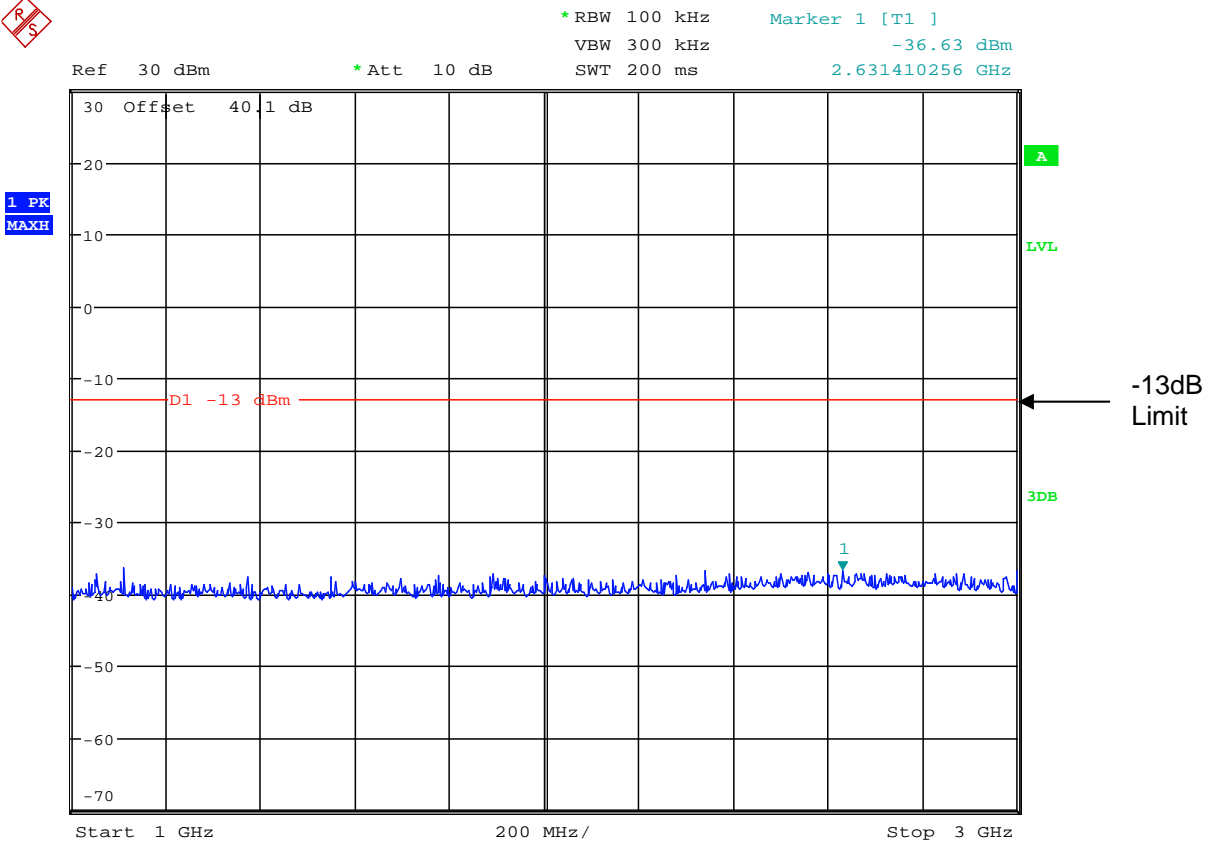

Date: 23.MAY.2011 11:24:28

# 3GHz – 5GHz



Ref 30 dBm      \* Att 10 dB      \* RBW 100 kHz      Marker 1 [T1 ]  
VBW 300 kHz      -37.30 dBm  
SWT 200 ms      3.429487179 GHz

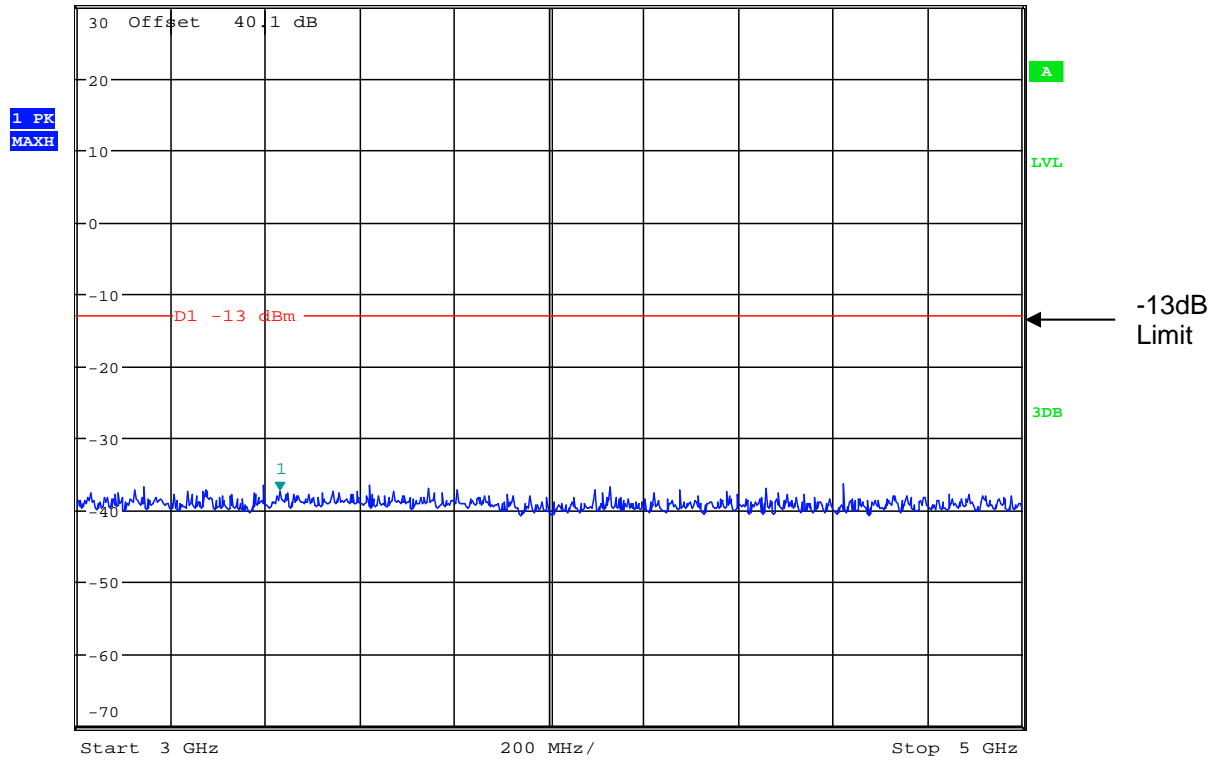

Date: 23.MAY.2011 11:24:15

## TRANSMITTER TESTS

### AMPLIFIER MODULATED CHANNEL TEST – CONDUCTED – Part 2.1049– UHF UPLINK

Ambient temperature = 24°C Radio Laboratory  
 Relative humidity = 50%  
 Supply voltage = +110Vac  
 Channel number = See test results

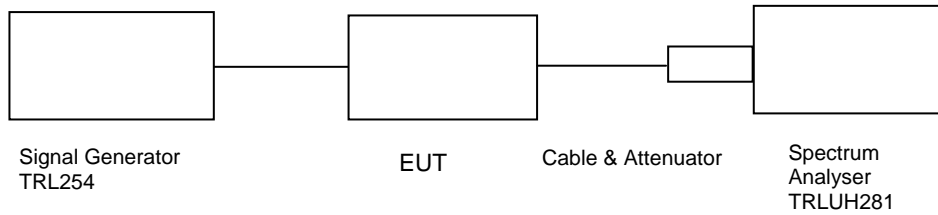

This test was performed to show that the amplifier does not alter the input signal in any way. The input signal was set to the maximum input and modulated with a 2500Hz tone. The plots show the signal measured at the signal generator and the signal measured at the output of the EUT.

Note: The cables and attenuators had the following losses.

1. Cable and attenuator between EUT and spectrum analyser 40.10dB
2. Cable between signal generator and EUT 0.10dB
3. See Table below for 99% Power Occupied Bandwidth

Frequency Of Operation Channel	Modulation Type
	2.5kHz Deviation FM
465.000MHz	99% Bandwidth =10.128kHz
465.500MHz	99% Bandwidth =10.128kHz
466.000MHz	99% Bandwidth =10.128kHz

TYPE OF EQUIPMENT	MAKER/SUPPLIER	MODEL No	SERIAL No	TRL No	ACTUAL EQUIPMENT USED
SPECTRUM ANALYSER	RHODE & SCHWARZ	FSU46	200034	UH281	X
ATTENUATOR	BIRD	8308-200-N	N/A	103	X
ATTENUATOR	BIRD	8304-100-N	N/A	222	X
CABLE	TRL	N/A	N/A	UH271	X
CABLE	TRL	N/A	N/A	UH272	X
CABLE	TRL	N/A	N/A	UH273	X
SIGNAL GENERATOR	RHODE & SCHWARZ	Vector Signal Generator	255812	916	X

465.000MHz Signal Generator, and EUT deviation set to 2.5kHz FM

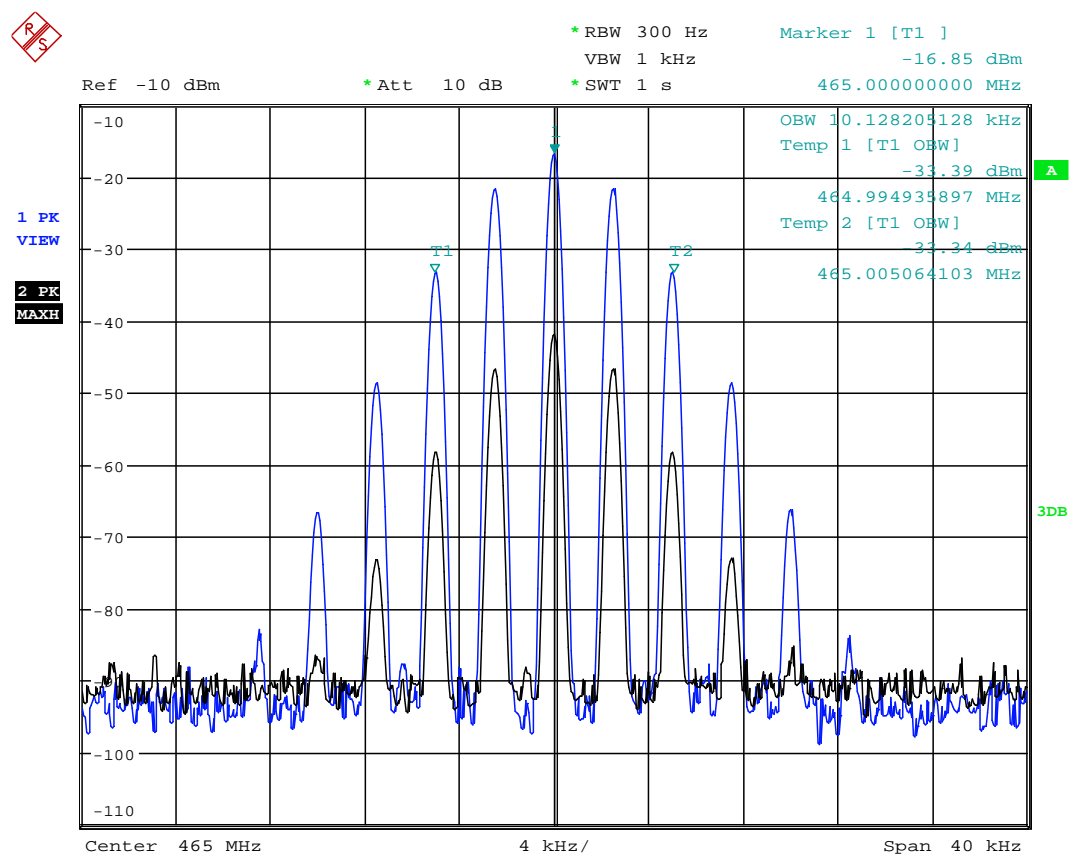

Date: 23.MAY.2011 13:06:28

# 465.500MHz Signal Generator, and EUT deviation set to 2.5kHz FM

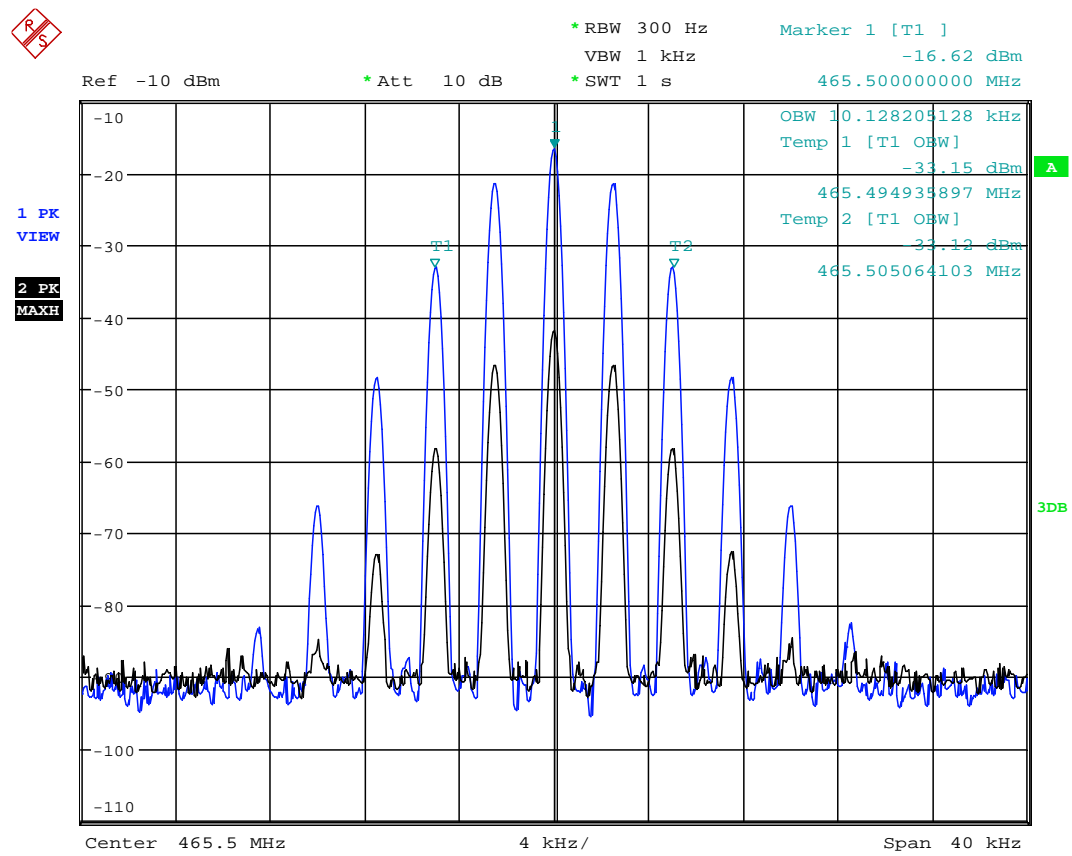

Date: 23.MAY.2011 13:08:10



# 466.000MHz Signal Generator, and EUT deviation set to 2.5kHz FM

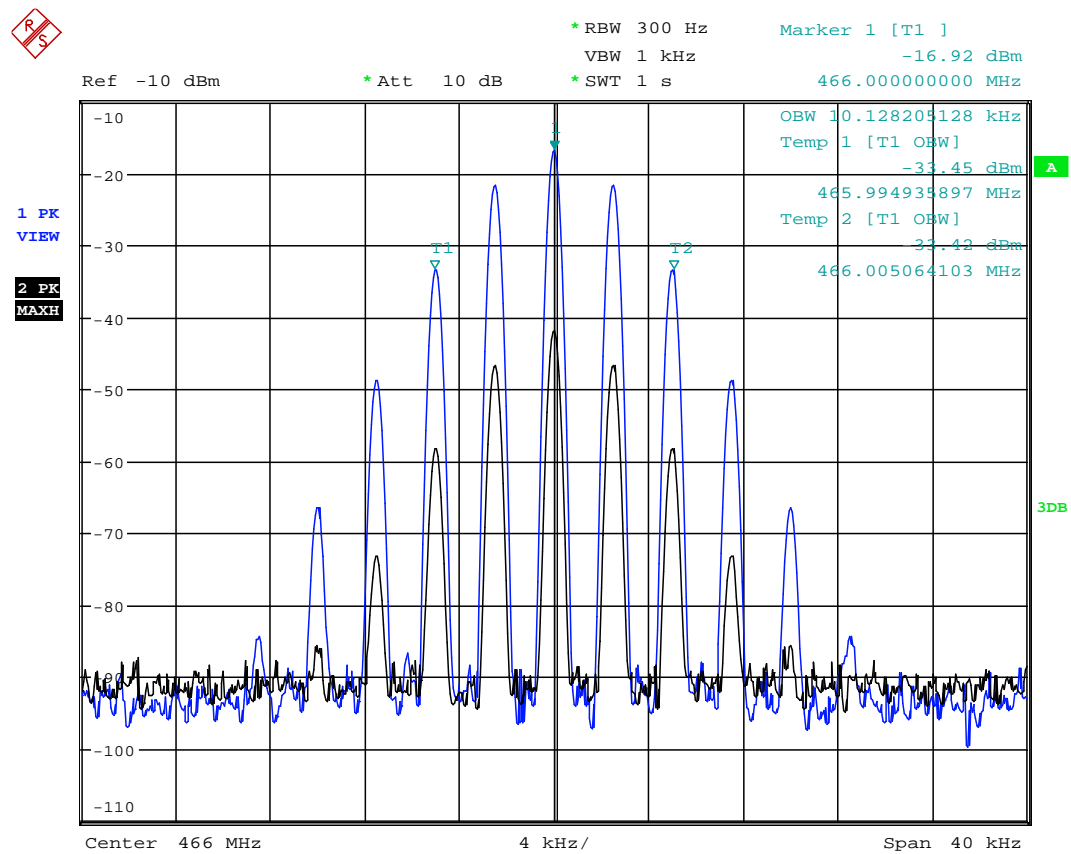

Date: 23.MAY.2011 13:12:16

The above plots depicting the output waveshape show no measurable distortion visible when compared to the input signal.

## TRANSMITTER TESTS

### AMPLIFIER SPURIOUS EMISSIONS – CONDUCTED – Part 2.1053 – UHF UPLINK

Ambient temperature = 24°C  
 Relative humidity = 50%  
 Supply voltage = +110Vac

Radio Laboratory  
 Test Signal = F3E

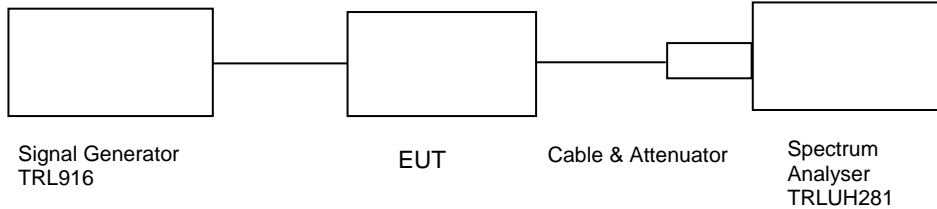

The test was set up as per the diagram. The level at the input was adjusted to compensate for the loss of the interconnecting cable. The unit was tested operating at maximum power and on three test frequencies.

The Spurious limit was calculated as follows:

On any frequency removed from the assigned frequency by more than 250% of the authorised bandwidth

At least  $43 + 10 \log P_{dB}$

$$(10 \log P_{\text{watts}}) - (43 + 10 \log (P_{\text{watts}} * 1000)) = \text{LIMIT} = -13 \text{ dBm}$$

### RESULTS

FREQUENCY RANGE	EMISSION FREQ. (MHz)	EMISSION LEVEL (dBm)	LIMIT (dBm)
30MHz – 5 GHz	No Significant Emissions within 20dB of the Limit		-13

The test equipment used for the Transmitter Conducted Emissions:

TYPE OF EQUIPMENT	MAKER/SUPPLIER	MODEL No	SERIAL No	TRL No	ACTUAL EQUIPMENT USED
SPECTRUM ANALYSER	RHODE & SCHWARZ	FSU46	200034	UH281	<b>X</b>
ATTENUATOR	BIRD	8308-200-N	N/A	103	<b>X</b>
ATTENUATOR	BIRD	8304-100-N	N/A	222	<b>X</b>
CABLE	TRL	N/A	N/A	UH271	<b>X</b>
CABLE	TRL	N/A	N/A	UH272	<b>X</b>
CABLE	TRL	N/A	N/A	UH273	<b>X</b>
SIGNAL GENERATOR	RHODE & SCHWARZ	Vector Signal Generator	255812	916	<b>X</b>

# Conducted emissions Bottom Channel

465.00MHz 30MHz – 1GHz

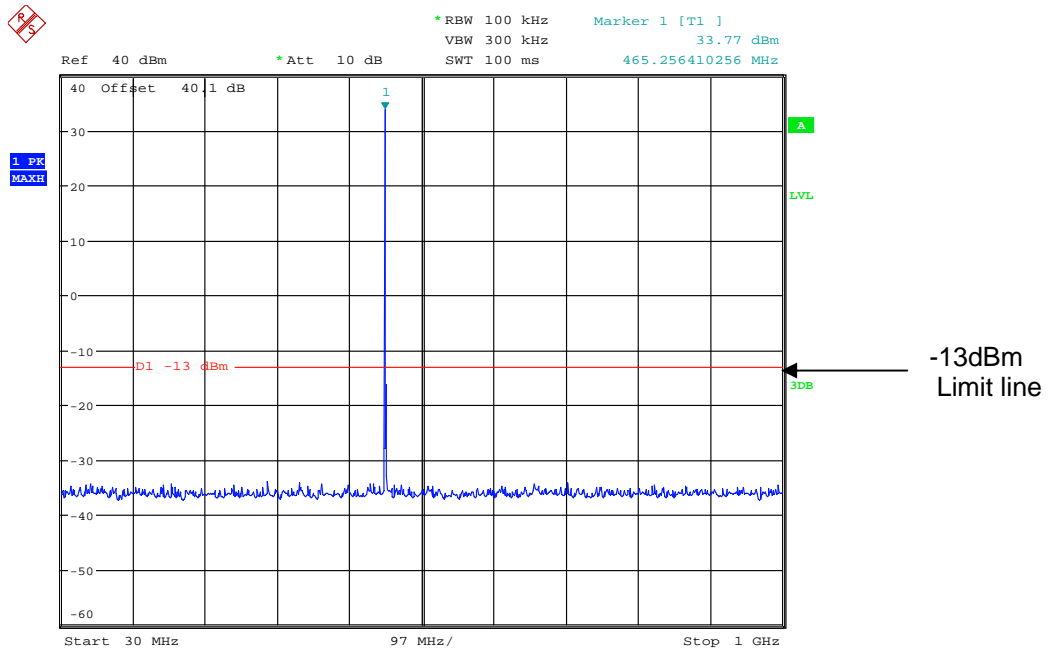

Date: 23.MAY.2011 11:29:37

465.00MHz 1GHz - 3GHz

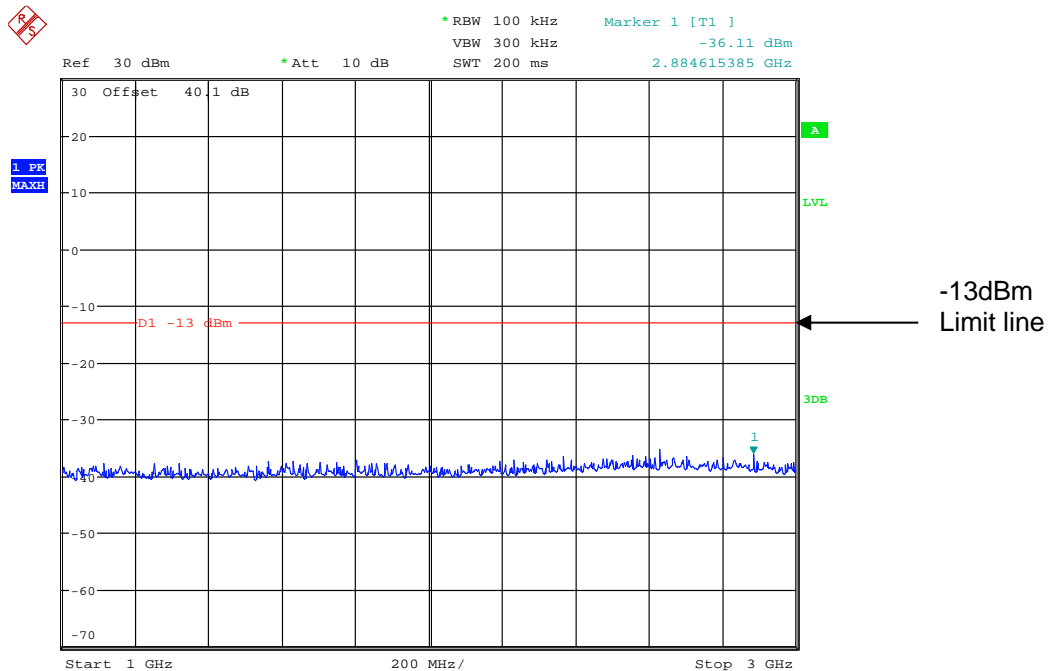

Date: 23.MAY.2011 11:30:01

465.00MHz 3GHz – 5GHz

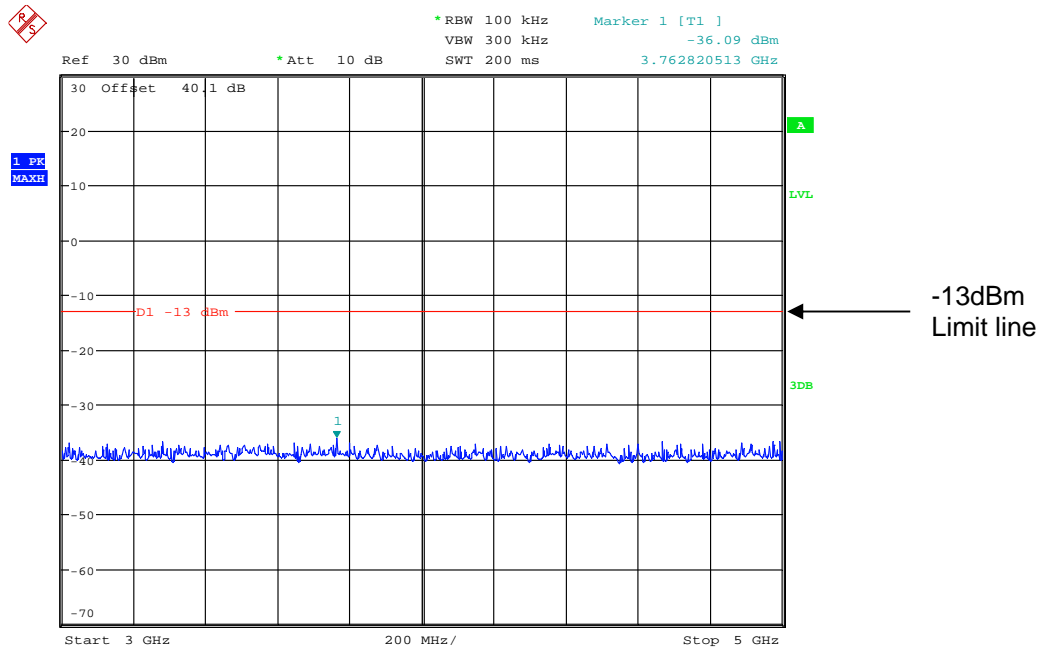

Date: 23.MAY.2011 11:30:18

# Conducted emissions Middle Channel

465.500MHz 30MHz – 1GHz

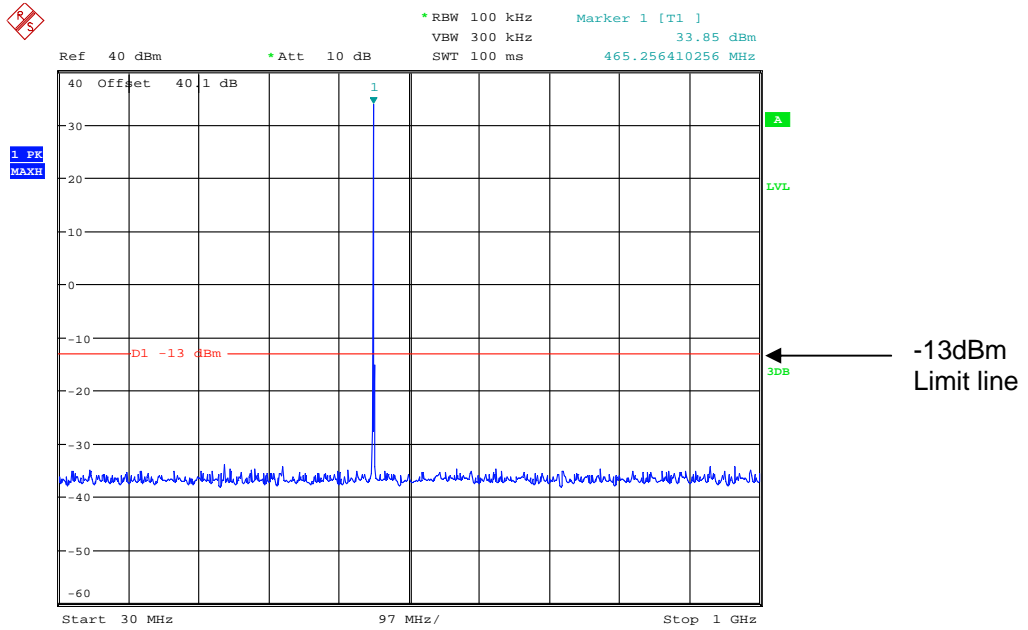

Date: 23.MAY.2011 11:31:43

465.500MHz 1GHz – 3GHz

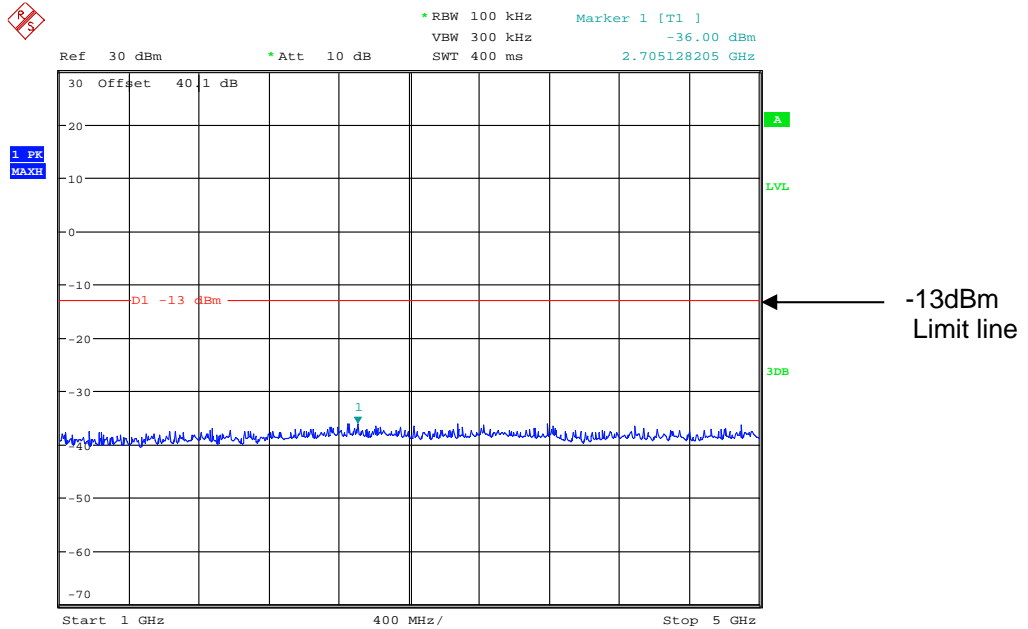

Date: 23.MAY.2011 11:31:25

# 465.500MHz 3GHz – 5GHz

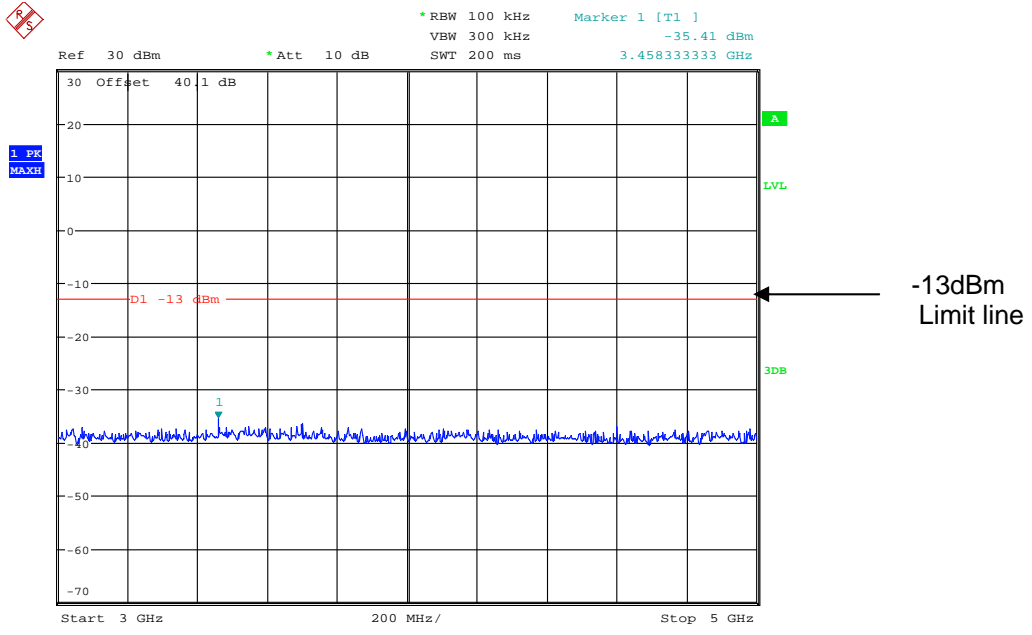

Date: 23.MAY.2011 11:30:54

# Conducted emissions Top Channel

466.00MHz 30MHz – 1GHz

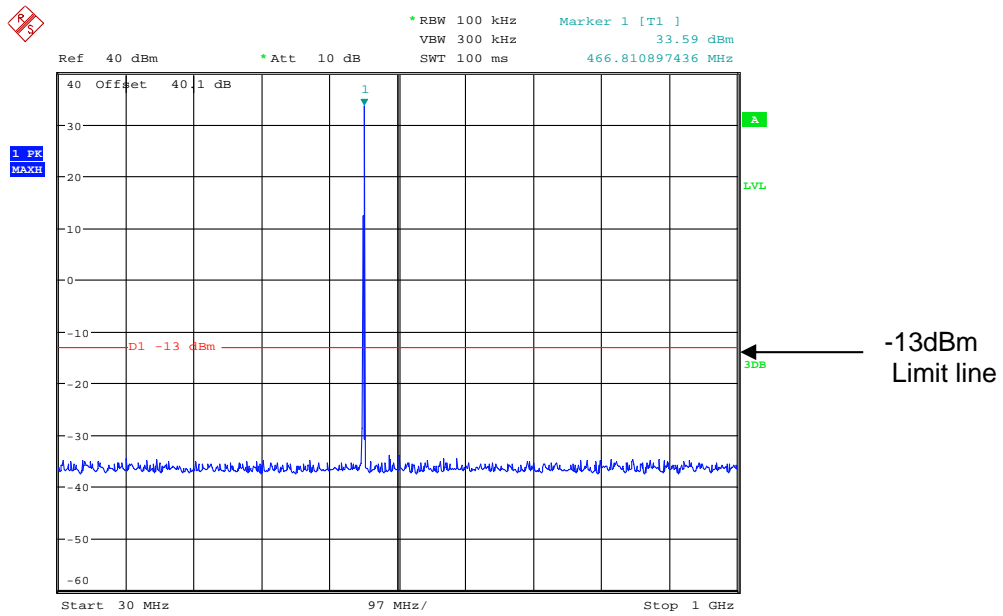

Date: 23.MAY.2011 11:31:59

466.00MHz 1GHz – 3GHz

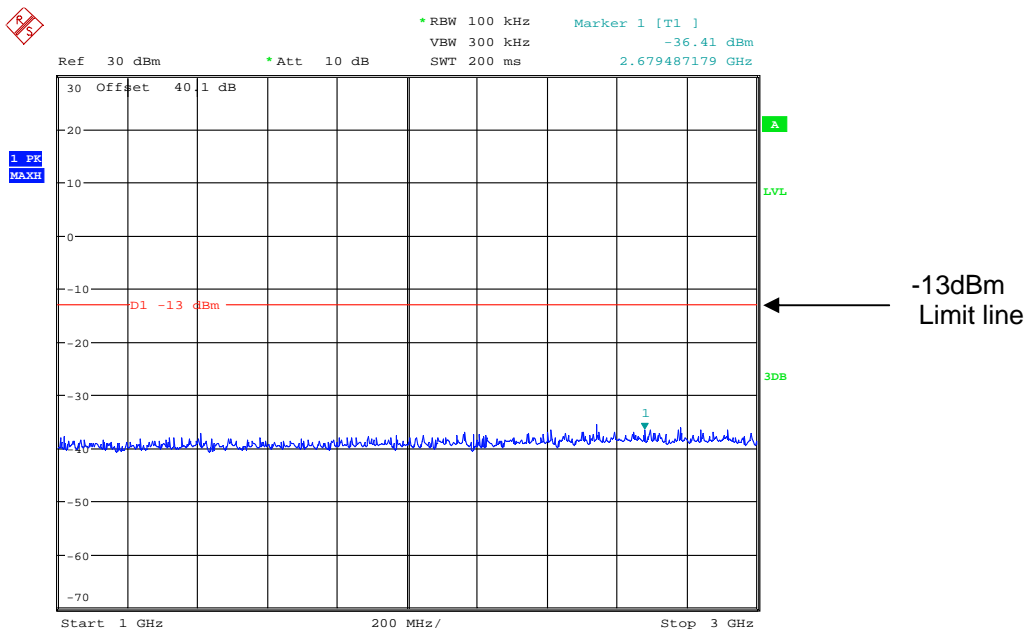

Date: 23.MAY.2011 11:32:18

466.00MHz 3GHz – 5GHz

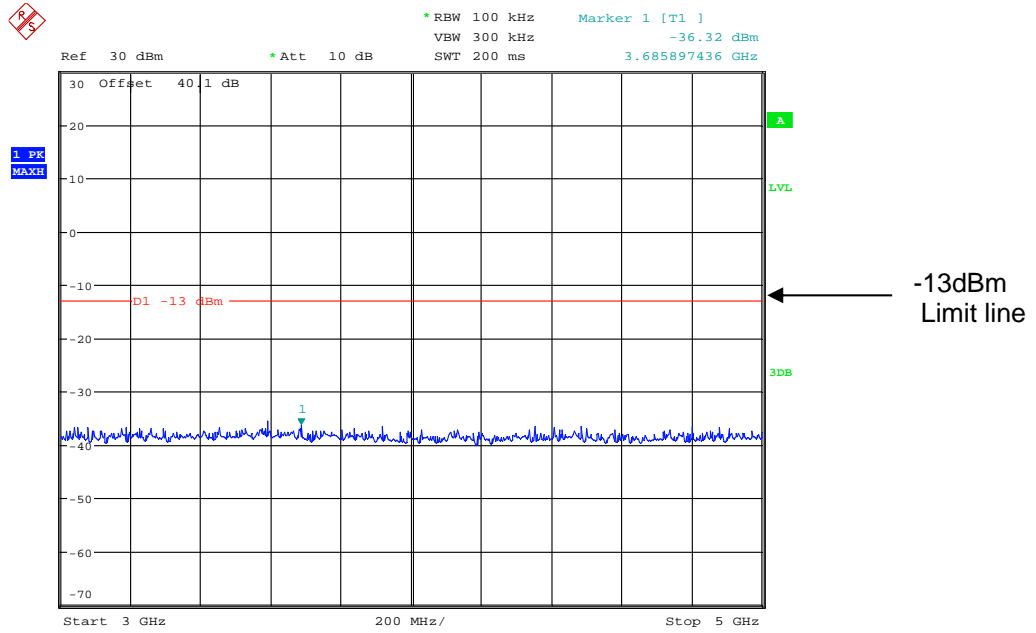

Date: 23.MAY.2011 11:32:50



## AMPLIFIER SPURIOUS EMISSIONS – RADIATED – Part 2.1053– UHF UPLINK

Ambient temperature = 24°C  
 Relative humidity = 50%  
 Conditions = OATS  
 Supply voltage = +110Vac  
 Supply Frequency = N/A  
 Test Signal = F3E

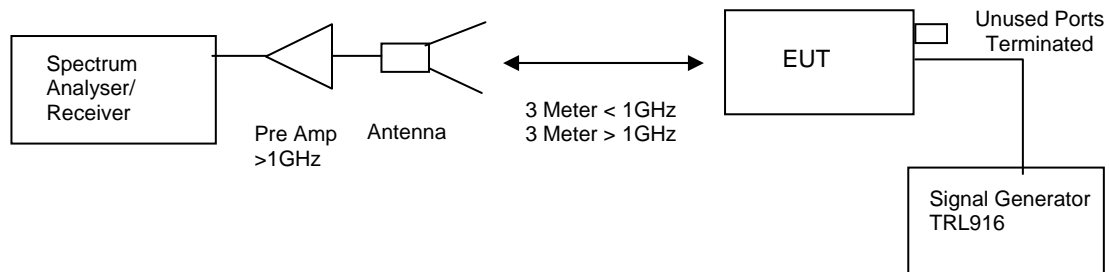

The test was set up as per the diagram. The level at the input was adjusted to compensate for the loss of the interconnecting cable. The unit was tested operating maximum power on three test frequencies with a 50 ohm load on the output. The unit was also tested with the signal generator replaced by another 50ohm load.

The Spurious limit was calculated as follows:

On any frequency removed from the assigned frequency by more that 250% of the authorised bandwidth

At least  $43 + 10 \log P_{dB}$

$(10 \log P_{watts}) - (43 + 10 \log (P_{watts} * 1000)) = \text{LIMIT} = -13 \text{ dBm}$

### RESULTS

FREQUENCY RANGE	FREQ. (MHz)	MEAS. Rx. (dBµV)	CABLE LOSS (dB)	ANT FACTOR	FIELD STRENGTH (dBµV/m)	CALCULATED EIRP (dBm)	LIMIT (dBm)
30MHz – 5GHz	No Significant Emissions Within 20dB of Limit.						-13

The test equipment used for the Transmitter Spurious Emissions:

TYPE OF EQUIPMENT	MAKER/SUPPLIER	MODEL No	SERIAL No	TRL No	ACTUAL EQUIPMENT USED
HORN	EMCO	3115	9010-3580	138	X
SPECTRUM ANALYSER	R&S	FSU46	200034	UH281	X
PRE AMPLIFIER	HP	8449B	3008A016	572	X
SIGNAL GENERATOR	RHODE & SCHWARZ	Vector Signal Generator	255812	916	X
ANTENNA	YORK	CBL611/A	1618	UH191	X

# Radiated emissions Bottom Channel

465.000MHz 30MHz – 1GHz

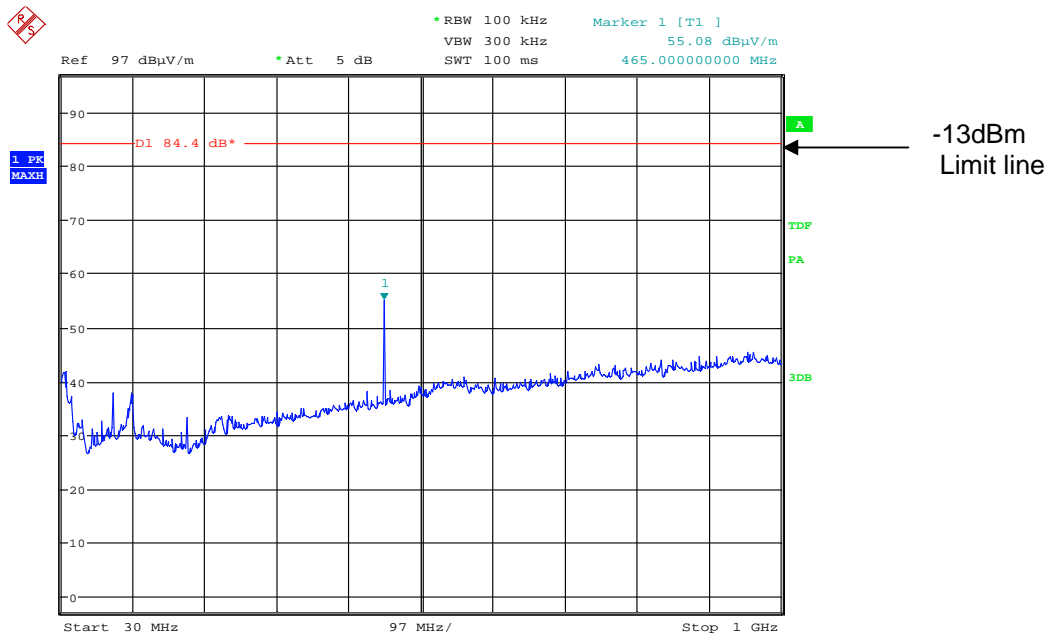

Date: 20.MAY.2011 10:43:49

465.000MHz 1GHz – 3GHz

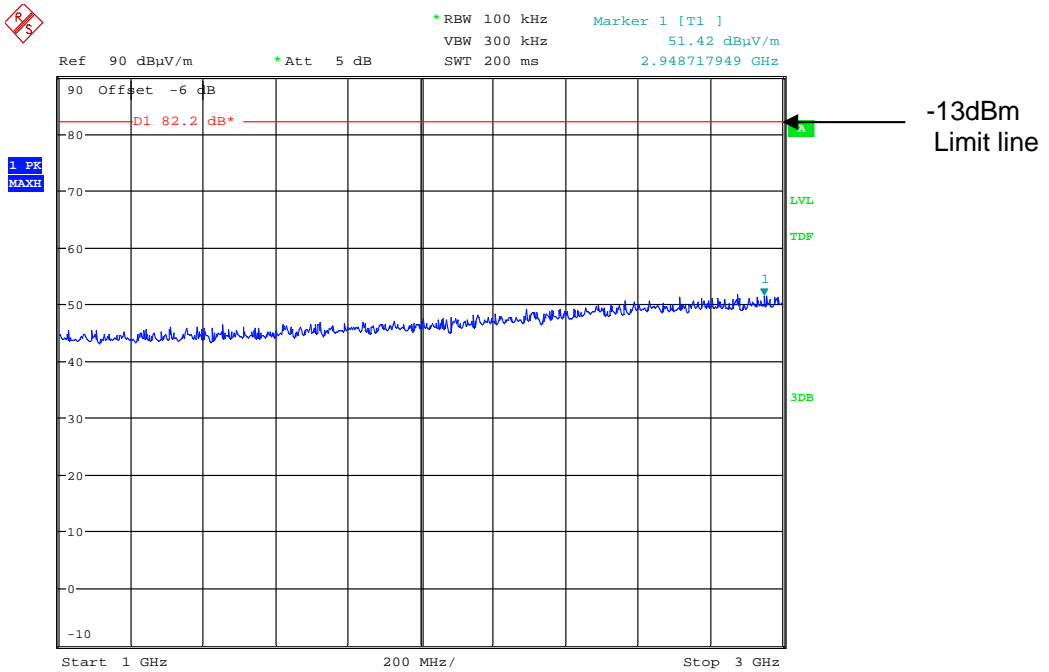

Date: 20.MAY.2011 09:28:13

465.000MHz 3GHz – 5GHz

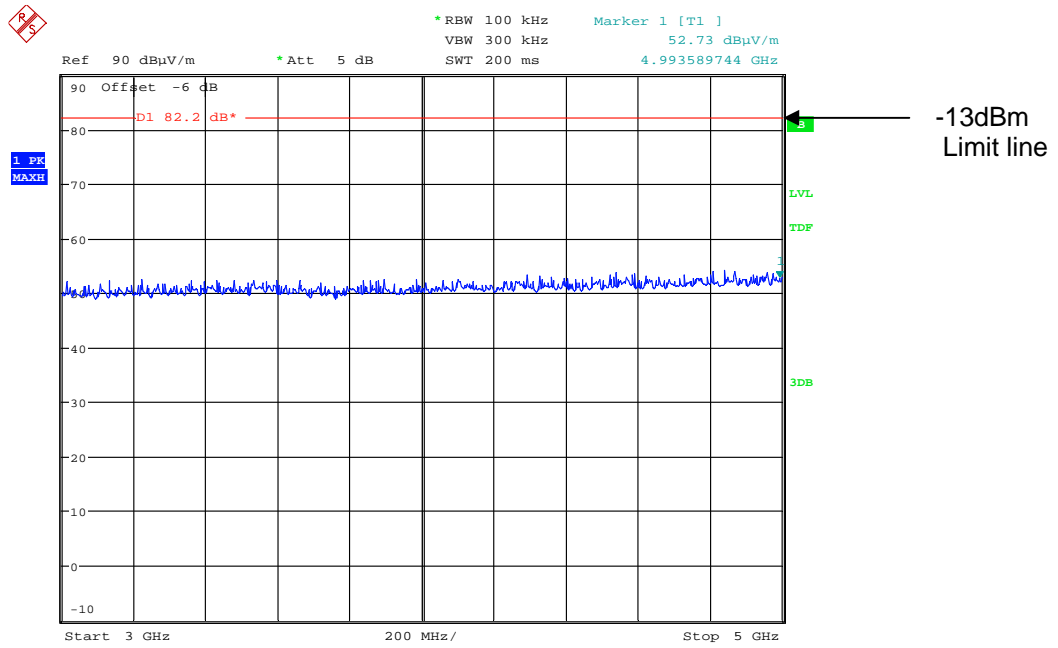

Date: 20.MAY.2011 09:27:54

The above test results show that there were no emissions within 20dBs of the -13dBm limit.

# Radiated emissions Middle Low Channel

465.500MHz - 30MHz – 1GHz

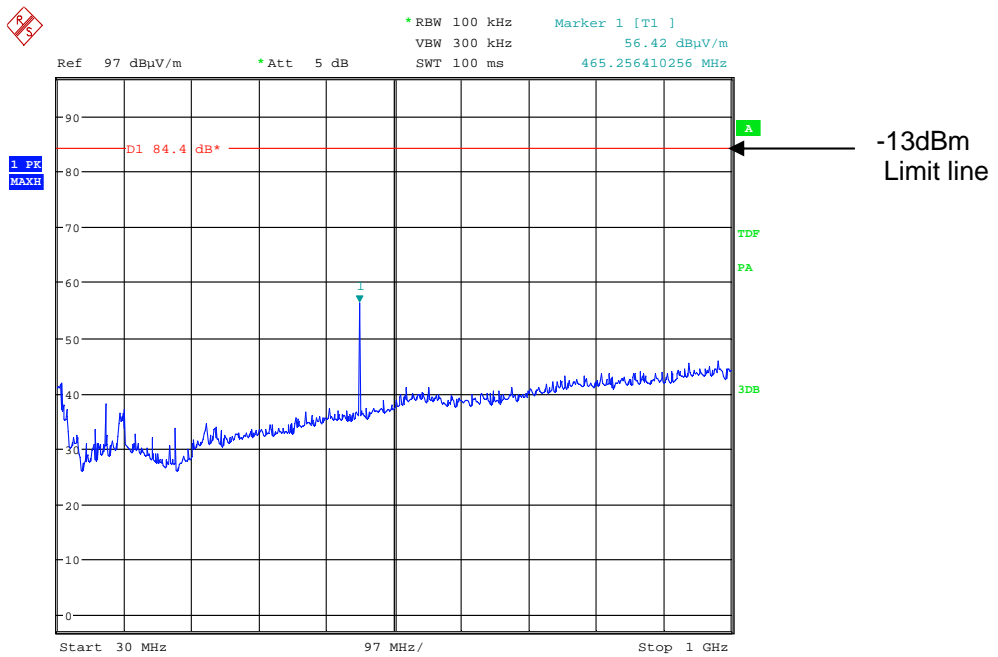

Date: 20.MAY.2011 10:43:20

465.500MHz 1GHz – 3GHz

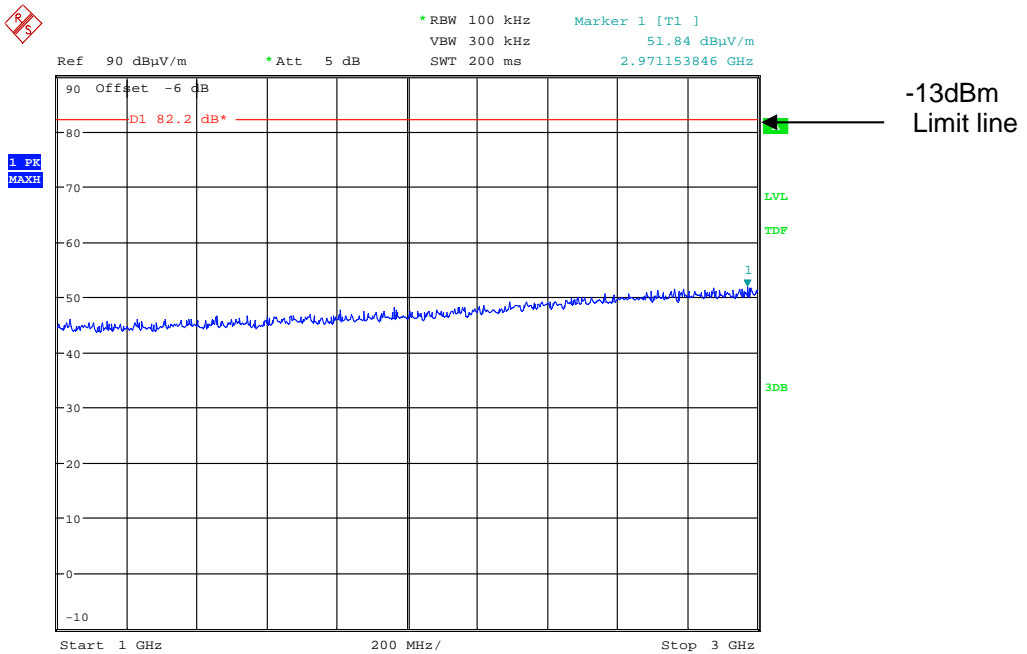

Date: 20.MAY.2011 09:28:37

# 465.500MHz 3GHz – 5GHz

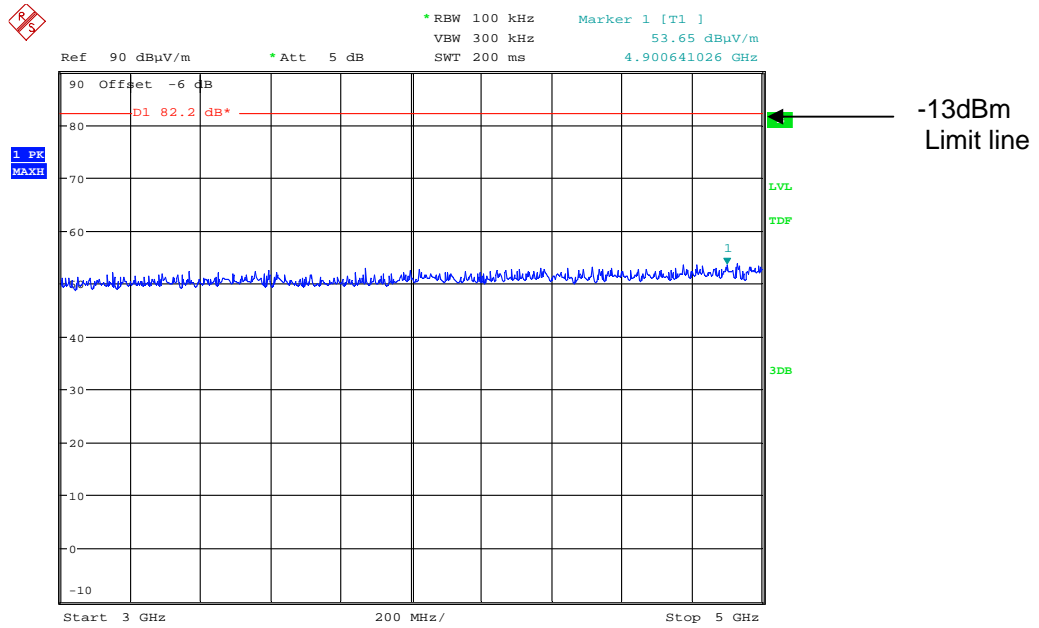

Date: 20.MAY.2011 09:28:54

The above test results show that there were no emissions within 20dBs of the -13dBm limit.

# Radiated emissions Top Channel

466.00MHz 30MHz – 1GHz

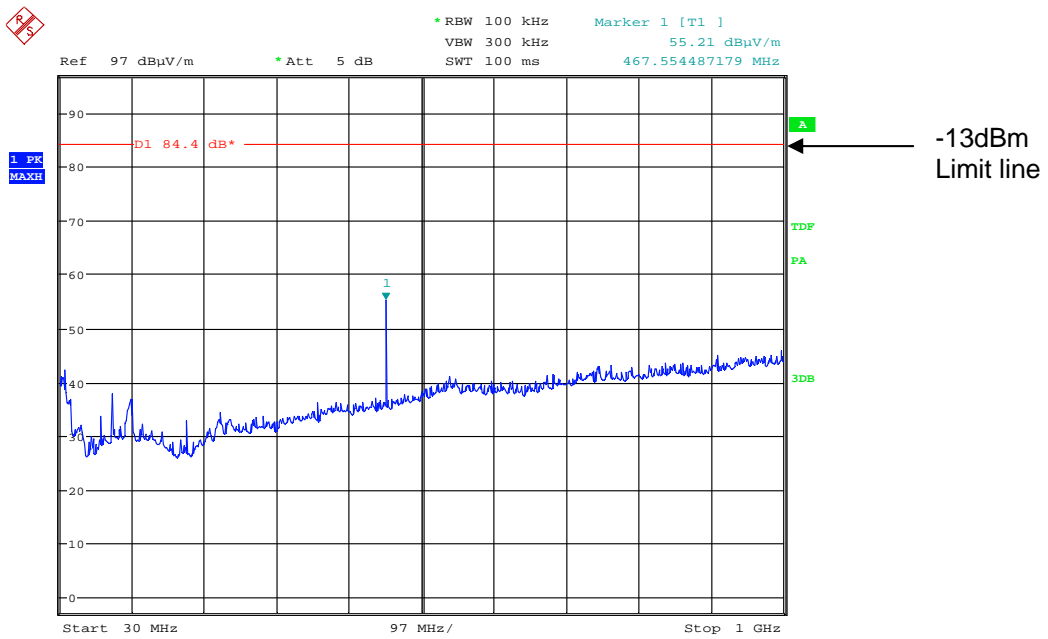

Date: 20.MAY.2011 10:43:01

466.00MHz 1GHz – 3GHz

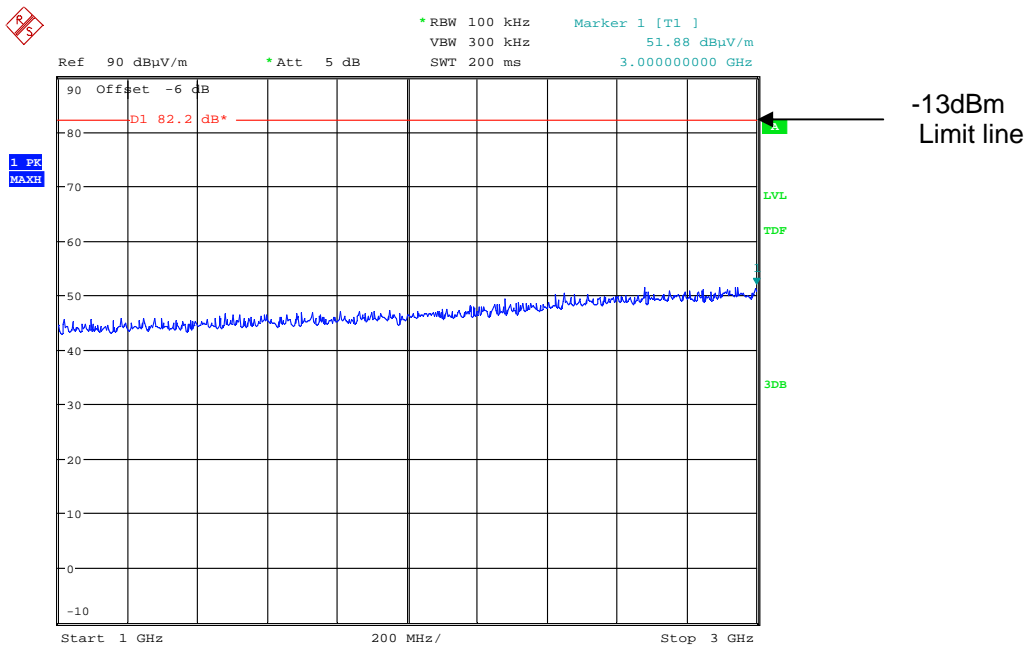

Date: 20.MAY.2011 09:29:35

466.00MHz 3GHz – 5GHz

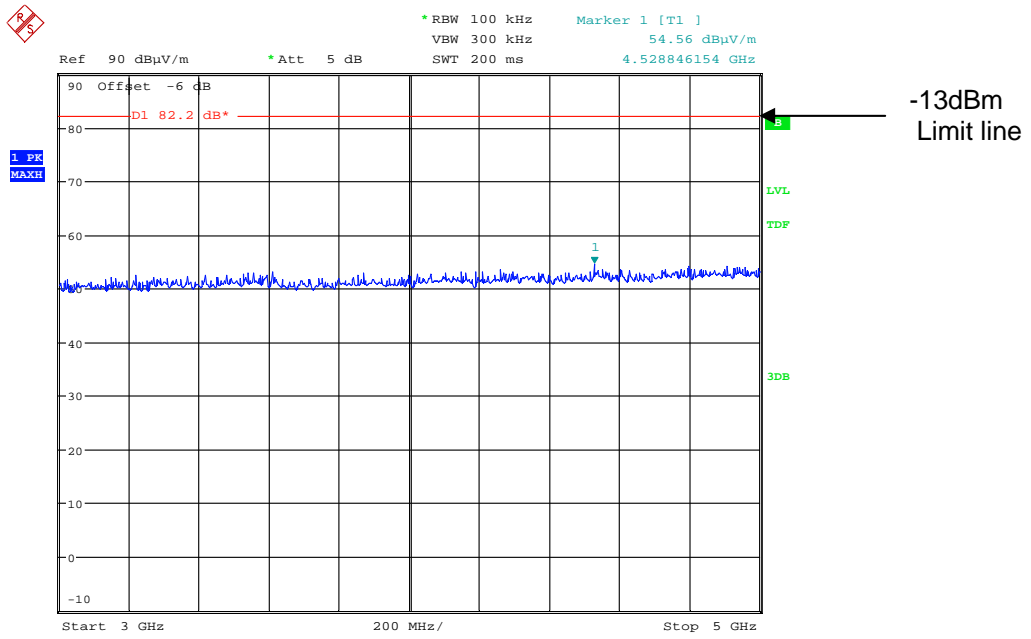

Date: 20.MAY.2011 09:29:17

The above test results show that there were no emissions within 20dBs of the -13dBm limit.

**ANNEX A**  
**PHOTOGRAPHS**







**ANNEX B**  
**APPLICANT'S SUBMISSION OF DOCUMENTATION LIST**

### APPLICANT'S SUBMISSION OF DOCUMENTATION LIST

a.	TCB	-	APPLICATION	[X]
		-	FEE	[X]
b.	AGENT'S LETTER OF AUTHORISATION	-		[X]
c.	MODEL(s) vs IDENTITY	-		[ ]
d.	ALTERNATIVE TRADE NAME DECLARATION(s)	-		[ ]
e.	LABELLING	-	PHOTOGRAPHS	[ ]
		-	DECLARATION	[ ]
		-	DRAWINGS	[ ]
f.	TECHNICAL DESCRIPTION	-		[X]
g.	BLOCK DIAGRAMS	-	Tx	[X]
		-	Rx	[ ]
		-	PSU	[ ]
		-	AUX	[ ]
h.	CIRCUIT DIAGRAMS	-	Tx	[X]
		-	Rx	[ ]
		-	PSU	[ ]
		-	AUX	[ ]
i.	COMPONENT LOCATION	-	Tx	[ ]
		-	Rx	[ ]
		-	PSU	[ ]
		-	AUX	[ ]
j.	PCB TRACK LAYOUT	-	Tx	[ ]
		-	Rx	[ ]
		-	PSU	[ ]
		-	AUX	[ ]
k.	BILL OF MATERIALS	-	Tx	[X]
		-	Rx	[ ]
		-	PSU	[ ]
		-	AUX	[ ]
l.	USER INSTALLATION / OPERATING INSTRUCTIONS	-		[X]

**ANNEX C**  
**EQUIPMENT CALIBRATION**

REF Number	Equipment Type	Manufacturer	Last Cal Calibration	Calibration Period	Due For Calibration
UH003	Receiver	R&S	13/01/2011	12	13/01/2012
UH004	Receiver	R&S	14/12/2010	12	14/12/2011
UH06/07	IC OATS Submission	TRL	02/07/2009	24	02/07/2011
UH06/07	NSA Calibration	TRL	24/06/2010	12	24/06/2011
UH093	Bilog	Chase	03/06/2009	24	03/06/2011
UH191	Bilog	Chase	08/11/2010	24	08/11/2012
UH253	1m Cable N type	TRL	01/03/2011	12	01/03/2012
UH254	1m Cable N type	TRL	01/03/2011	12	01/03/2012
UH269	1m Cable N type	TRL	01/03/2011	12	01/03/2012
UH270	1m Cable N type	TRL	01/03/2011	12	01/03/2012
UH271	1.5m Cable N type	TRL	01/03/2011	12	01/03/2012
UH272	1.5m Cable N type	TRL	01/03/2011	12	01/03/2012
UH273	2m Cable N type	TRL	01/03/2011	12	01/03/2012
UH274	2m Cable N type	TRL	01/03/2011	12	01/03/2012
UH281	Spectrum Analyser	R&S	10/02/2011	12	10/02/2012
UH288	1m Cable N type	N/A	01/03/2011	12	01/03/2012
UH293	K-Type Cable	Megaphase	24/11/2010	12	24/11/2011
UH372	PreAmp	Wat-John	14/04/2010	12	14/04/2011
UH377	ESU 26	R&S	11/06/2010	13	11/07/2011
UH378	3M Cable	TRaC	01/03/2011	12	01/03/2012
UH387	Chamber 1	Rainford EMC	26/06/2010	12	26/06/2011
UH388	Chamber 2	Rainford EMC	23/06/2010	12	23/06/2011
L138	1-18GHz Horn	EMCO	10/09/2009	24	10/09/2011
L139	1-18GHz Horn	EMCO	17/08/2009	24	17/08/2011
L176	Signal Generator	Marconi	08/07/2010	12	08/07/2011
L254	Signal Generator	Marconi	15/09/2010	12	15/09/2011
L572	Pre Amp	Agilent	24/11/2010	12	24/11/2011
L664	3M Cable	TRaC	01/03/2011	12	01/03/2012
REF910	Spectrum Analyser	R&S	27/10/2010	12	27/10/2011
TRL170	Combiner	Elcom		Calibrate in use	

**ANNEX D**  
**MEASUREMENT UNCERTAINTY**

## Radio Testing – General Uncertainty Schedule

All statements of uncertainty are expanded standard uncertainty using a coverage factor of 1.96 to give a 95% confidence where no required test level exists.

### **[1] Adjacent Channel Power**

Uncertainty in test result = **1.86dB**

### **[2] Carrier Power**

Uncertainty in test result (Equipment - TRLUH120) = **2.18dB**

Uncertainty in test result (Equipment – TRL05) = **1.08dB**

Uncertainty in test result (Equipment – TRL479) = **2.48dB**

### **[3] Effective Radiated Power**

Uncertainty in test result = **4.71dB**

### **[4] Spurious Emissions**

Uncertainty in test result = **4.75dB**

### **[5] Maximum frequency error**

Uncertainty in test result (Equipment - TRLUH120) = **119ppm**

Uncertainty in test result (Equipment – TRL05) = **0.113ppm**

Uncertainty in test result (Equipment – TRL479) = **0.265ppm**

### **[6] Radiated Emissions, field strength OATS 14kHz-18GHz Electric Field**

Uncertainty in test result (14kHz – 30MHz) = **4.8dB**, Uncertainty in test result (30MHz – 1GHz) = **4.6dB**,

Uncertainty in test result (1GHz-18GHz) = **4.7dB**

### **[7] Frequency deviation**

Uncertainty in test result = **3.2%**

### **[8] Magnetic Field Emissions**

Uncertainty in test result = **2.3dB**

### **[9] Conducted Spurious**

Uncertainty in test result (Equipment TRL479) Up to 8.1GHz = **3.31dB**

Uncertainty in test result (Equipment TRL479) 8.1GHz – 15.3GHz = **4.43dB**

Uncertainty in test result (Equipment TRL479) 15.3GHz – 21GHz = **5.34dB**

Uncertainty in test result (Equipment TRLUH120) Up to 26GHz = **3.14dB**

### **[10] Channel Bandwidth**

Uncertainty in test result = **15.5%**

### **[11] Amplitude and Time Measurement – Oscilloscope**

Uncertainty in overall test level = **2.1dB**, Uncertainty in time measurement = **0.59%**, Uncertainty in Amplitude measurement = **0.82%**

### **[11] Power Line Conduction**

Uncertainty in test result = **3.4dB**



**[12] Spectrum Mask Measurements**

Uncertainty in test result = **2.59% (frequency)**  
Uncertainty in test result = **1.32dB (amplitude)**

**[13] Adjacent Sub Band Selectivity**

Uncertainty in test result = **1.24dB**

**[14] Receiver Blocking – Listen Mode, Radiated**

Uncertainty in test result = **3.42dB**

**[15] Receiver Blocking – Talk Mode, Radiated**

Uncertainty in test result = **3.36dB**

**[16] Receiver Blocking – Talk Mode, Conducted**

Uncertainty in test result = **1.24dB**

**[17] Receiver Threshold**

Uncertainty in test result = **3.23dB**

**[18] Transmission Time Measurement**

Uncertainty in test result = **7.98%**



**TRaC**

testing regulatory and compliance

