



TRL Compliance
part of TRAC global

**REPORT ON THE CERTIFICATION TESTING OF A
AXELL WIRELESS LIMITED
FIBRE-FEED REMOTE BOOSTER
WITH RESPECT TO
THE FCC RULES CFR 47, PART 27.
PRIVATE LAND MOBILE REPEATER.**



TEST REPORT NO: RU1482/8681
COPY NO: 1
ISSUE NO: 2
FCC ID: NEO60-2147SERIES

**REPORT ON THE CERTIFICATION TESTING OF A
AXELL WIRELESS LIMITED
FIBRE-FEED REMOTE BOOSTER
WITH RESPECT TO
THE FCC RULES CFR 47, PART 27.
PRIVATE LAND MOBILE REPEATER.**

TEST DATE: 16th – 19th June 2008

TESTED BY: _____ S HODGKINSON
APPROVED BY: _____ J CHARTERS
RADIO SECTION
LEADER
DATE: 4th March 2009 _____

Distribution:

- Copy Nos:
1. Axell Wireless Limited
 2. TCB: TRL Compliance Limited
 3. TRL Compliance Ltd

THIS DOCUMENT MAY BE REPRODUCED ONLY IN ITS ENTIRETY AND WITHOUT CHANGE

CONTENTS

	PAGE		
CERTIFICATE OF CONFORMITY & COMPLIANCE	3		
APPLICANT'S SUMMARY	4		
EQUIPMENT TEST CONDITIONS	5		
TESTS REQUIRED	5		
TEST RESULTS	7-50		
		ANNEX	
PHOTOGRAPHS		A	
PHOTOGRAPH No. 1: Test setup			
PHOTOGRAPH No. 2: Test setup			
PHOTOGRAPH No. 3: Test setup			
APPLICANT'S SUBMISSION OF DOCUMENTATION LIST		B	
EQUIPMENT CALIBRATION		C	
MEASUREMENT UNCERTAINTY		D	
 Notes:			
1.	Component failure during test	YES	<input type="checkbox"/>
		NO	<input checked="" type="checkbox"/>
2.	If Yes, details of failure:		
3.	The facilities used for the testing of the product contain in this report are FCC Listed.		



TRL Compliance

part of TRAC global

CERTIFICATE OF CONFORMITY & COMPLIANCE

FCC IDENTITY:	NEO60-2147SERIES
PURPOSE OF TEST:	Certification
TEST SPECIFICATION:	FCC RULES CFR 47, Part 27.
TEST RESULT:	Compliant to Specification
EQUIPMENT UNDER TEST:	Fibre Feed Remote Booster
EQUIPMENT TYPE:	Private Land Mobile Repeater
MAXIMUM GAIN:	Uplink 51.68dB Downlink 54.92dB
MAXIMUM INPUT:	Uplink -51.51dBm Downlink -20.70dBm
MAXIMUM OUTPUT CONDUCTED:	Uplink -0.03dBm Downlink 32.95dBm
CHANNEL SPACING:	Not Applicable, Wideband
FREQUENCY GENERATION:	N/A
MODULATION TYPE:	D7E
POWER SOURCE(s):	+24Vdc
TEST DATE(s):	16 th -19 th June 2008
ORDER No(s):	50762
APPLICANT:	Axell Wireless Limited
ADDRESS:	Aerial House Asheridge Road Chesham Buckinghamshire HP5 2QD
TESTED BY:	----- S HODGKINSON
APPROVED BY:	----- J CHARTERS RADIO SECTION LEADER

RU1482/8681

APPLICANT'S SUMMARY

EQUIPMENT UNDER TEST (EUT): Fibre Feed Remote Booster

EQUIPMENT TYPE: Private Land Mobile Repeater

PURPOSE OF TEST: Certification

TEST SPECIFICATION(s): FCC RULES CFR 47, Part 27.

TEST RESULT: COMPLIANT Yes
No

APPLICANT'S CATEGORY: MANUFACTURER
IMPORTER
DISTRIBUTOR
TEST HOUSE
AGENT

APPLICANT'S ORDER No(s): 50762

APPLICANT'S CONTACT PERSON(s): Mr Peter Bradfield

E-mail address: Peter.bradfield@axellwireless.com

APPLICANT: Axell Wireless Limited

ADDRESS: Aerial House
Asheridge Road
Chesham
Buckinghamshire
HP5 2QD
United Kingdom

TEL: +44 (0)1494 777000

FAX: +44 (0)1494 778456

MANUFACTURER: Axell Wireless Limited

EUT(s) COUNTRY OF ORIGIN: United Kingdom

TEST LABORATORY: TRL Compliance Ltd

UKAS ACCREDITATION No: 0728

TEST DATE(s): 16th – 19th June 2008

TEST REPORT No: RU1482/8681

COMPLIANCE TESTS

AMPLIFIER GAIN – CONDUCTED – PART 27.55– UPLINK

Ambient temperature = 15°C
 Relative humidity = 44%
 Supply voltage = +24Vdc
 Channel number = See test results

Radio Laboratory

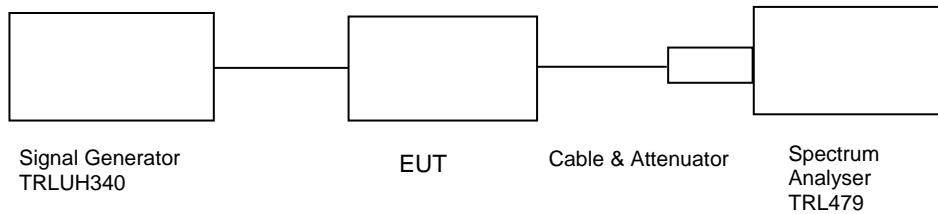

Frequency MHz	Signal Generator input level dBm	Input Cable Loss dB	Output Cable & Attenuator loss dB	Level at Spectrum Analyser dBm	Gain dB	Conducted Output Power dBm	Gain after 10dB input level increase dB
1710.0	-50.36	1.14	11.23	-11.52	51.22	-0.29	41.24
1732.5	-50.57	1.14	11.23	-11.26	51.68	-0.03	41.77
1755.0	-51.07	1.14	11.23	-12.55	50.89	-1.32	40.59

Notes: 1. The signal generator input was increased by 10dBs and the level of the output signal remeasured.

TYPE OF EQUIPMENT	MAKER/SUPPLIER	MODEL No	SERIAL No	TRL No	ACTUAL EQUIPMENT USED
SPECTRUM ANALYSER	ANRITSU	MS2665C	MT26089	479	X
ATTENUATOR	BIRD	8308-200-N	N/A	103	
ATTENUATOR	BIRD	8308-100-N	N/A	112	X
SIGNAL GENERATOR	HP	83630B	3722A00588	UH340	X

AMPLIFIER INTERMODULATION SPURIOUS EMISSIONS – CONDUCTED – PART 27.53 – UPLINK

Ambient temperature = 24°C
 Relative humidity = 44%
 Supply voltage = +24Vdc

Radio Laboratory

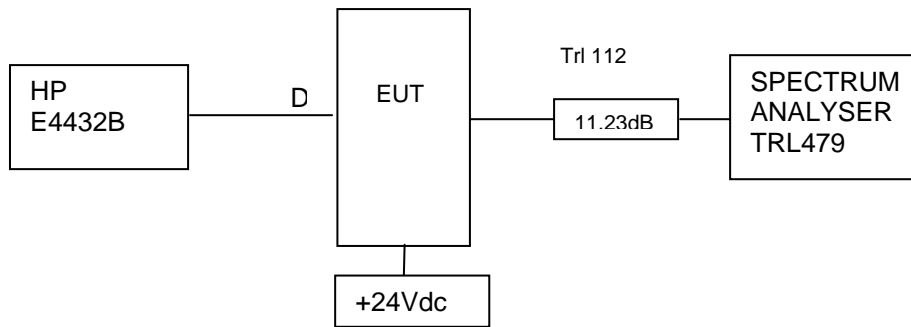

The intermodulation and spurious products were measured with the amplifier operating at maximum gain. A three tone test was conducted using the equipment as above. The input power level was adjusted so the level at point D was 10dB above the maximum input of -50.36dBm. The cable and attenuator loss between the EUT and the spectrum analyser was 11.23dB.

RF Input Frequency (MHz)			Highest Intermodulation Product Level (dBm)	Limit (dBm)
1737.0	1744.5	1752.0	No significant emissions within 20dB of the limit	-13

Sweep data is shown on the next page:

Test equipment used for intermodulation test

TYPE OF EQUIPMENT	MAKER/SUPPLIER	MODEL No	SERIAL No	TRL No	ACTUAL EQUIPMENT USED
SPECTRUM ANALYSER	ANRITSU	MS2665C	MT26089	479	X
SIGNAL GENERATOR	HP	E4432B	GB38100116		X
ATTENUATOR	BIRD	8308-100-N	N/A	112	X

Intermodulation Inband

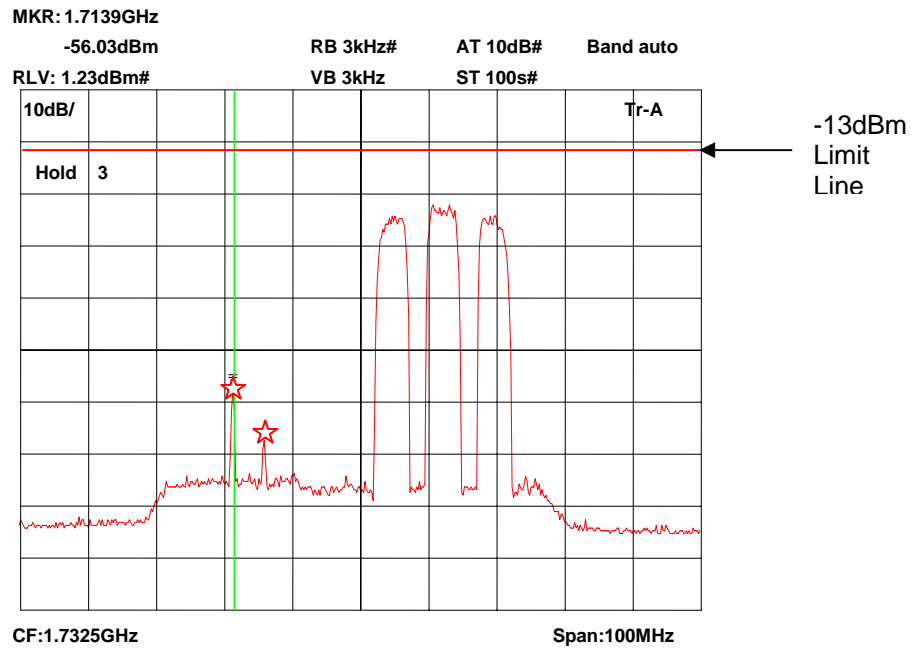

The above plot shows that all products (designated by ☆) are below the spurious limit.

Intermodulation Wideband

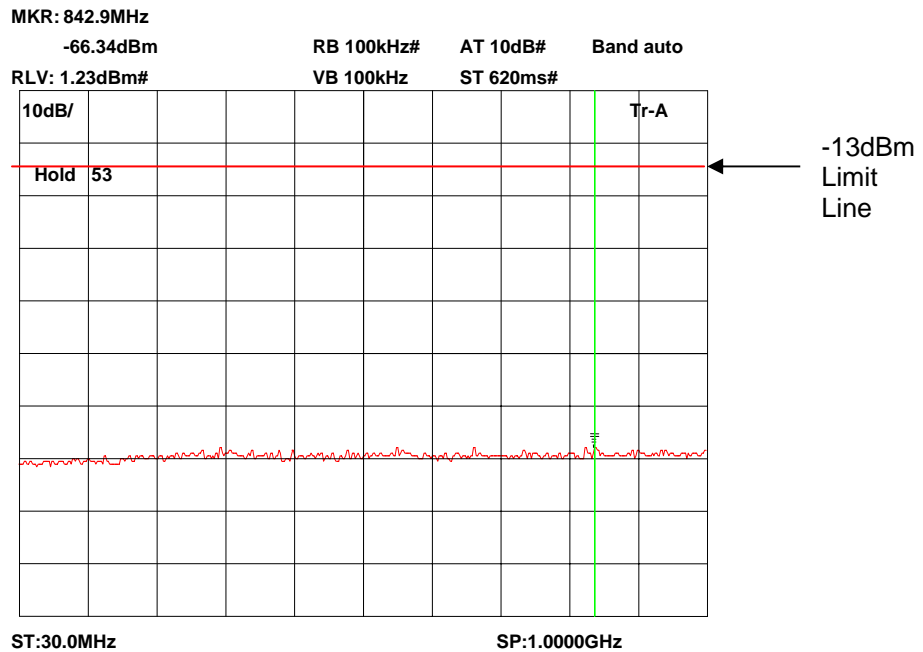
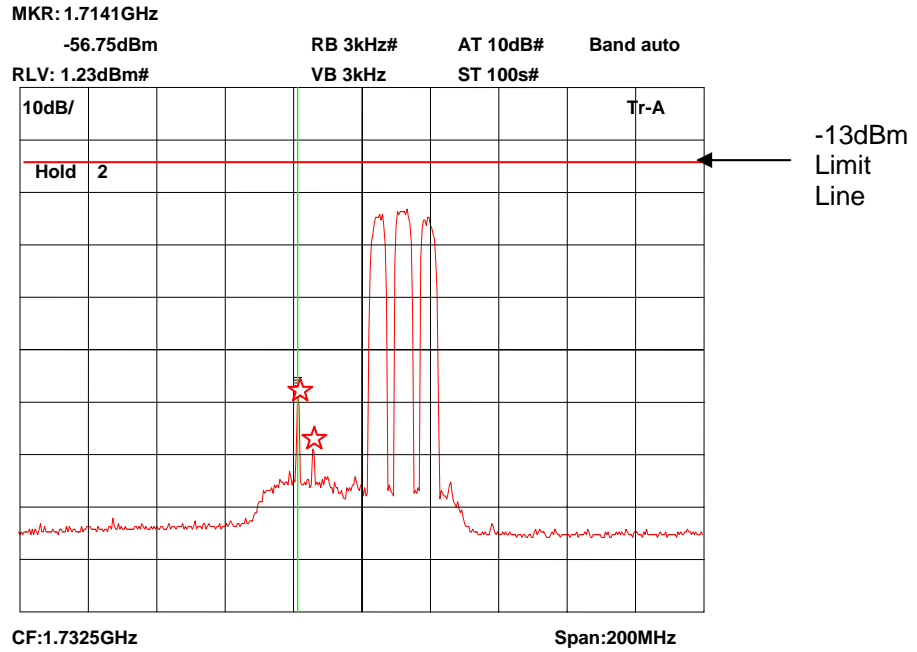

Intermodulation Wideband

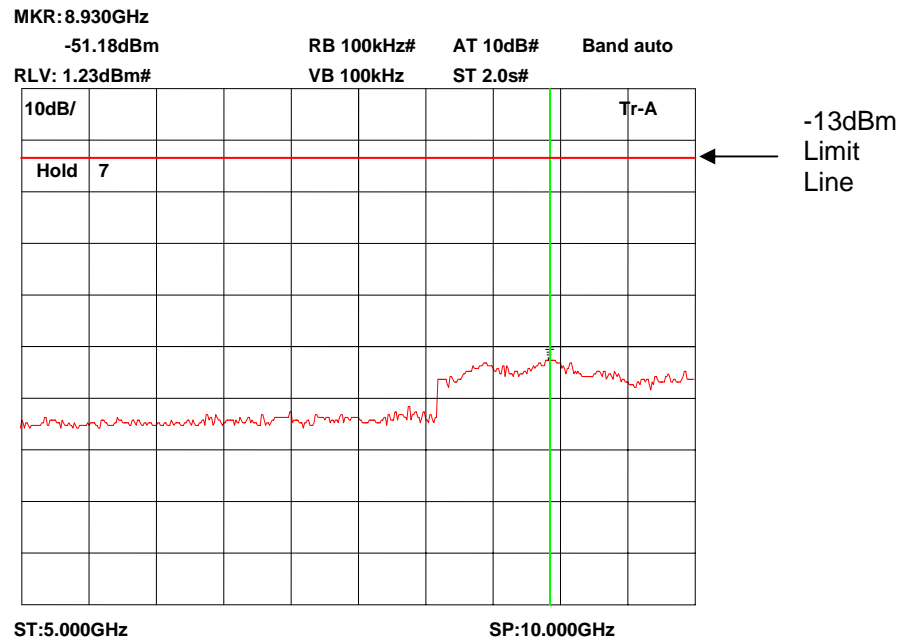
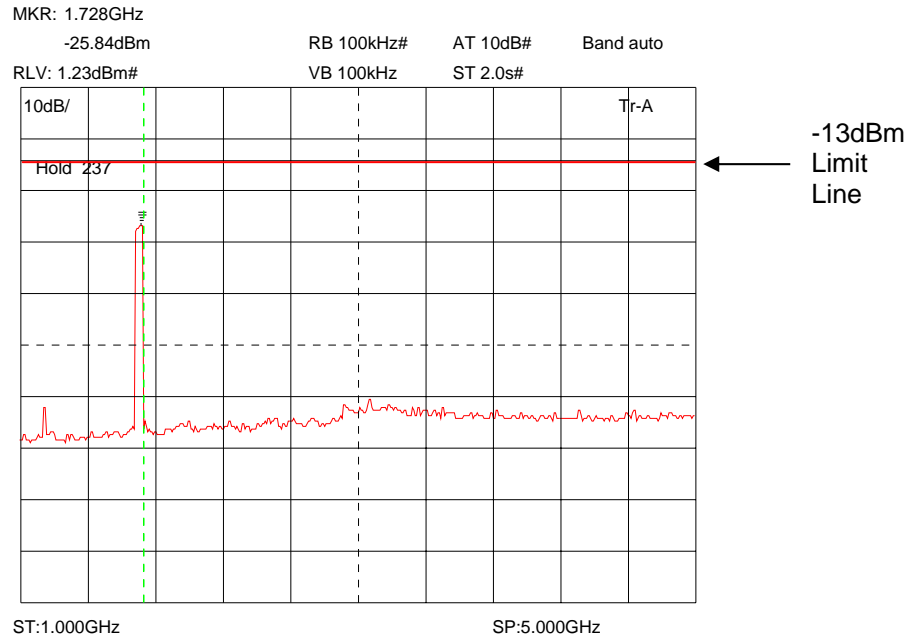

The above plots show that there are no products outside the bands.

Intermodulation Wideband

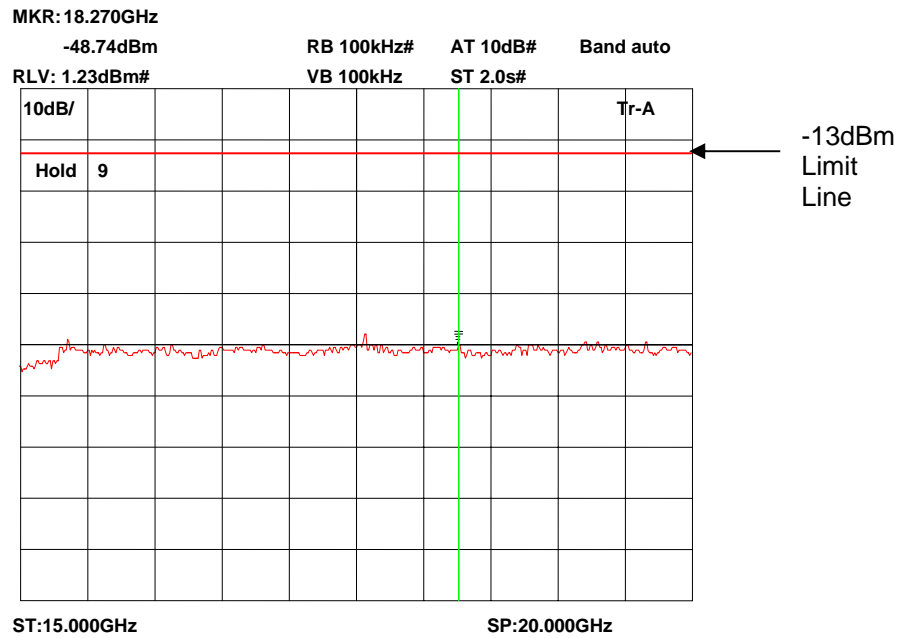
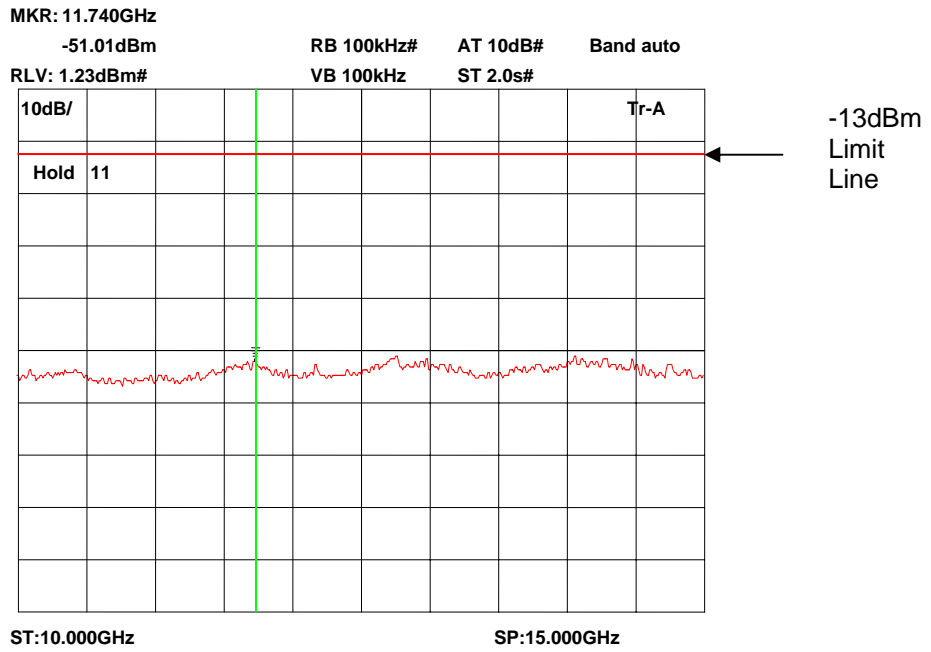

TRANSMITTER TESTS

AMPLIFIER MODULATED CHANNEL TEST – CONDUCTED – Part 27.53 – UPLINK

Ambient temperature = 19°C Radio Laboratory
 Relative humidity = 56%
 Supply voltage = +24Vdc
 Channel number = See test results

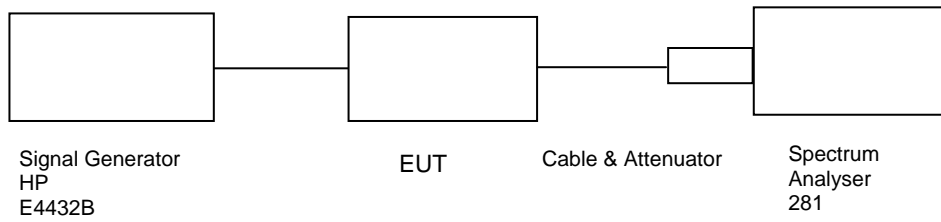

This test was performed to show that the amplifier does not alter the input signal in any way. The input signal was set to the maximum input level (-41.51dBm) and modulated with a WCDMA tone. The plots show the signal measured at the signal generator and the signal measured at the output of the EUT.

Note: The cables and attenuators had the following losses.

1. Cable and attenuator between EUT and spectrum analyser 11.23dB
2. Cable between signal generator and EUT 1.14dB

TYPE OF EQUIPMENT	MAKER/SUPPLIER	MODEL No	SERIAL No	TRL No	ACTUAL EQUIPMENT USED
SPECTRUM ANALYSER	R&S	FSU46	200034	UH281	X
ATTENUATOR	BIRD	8308-100-N	N/A	112	X
SIGNAL GENERATOR	HP	E4432B	GB38100116		X

Amplifier uplink

Bottom channel 1710.0MHz Signal Generator and EUT, WCDMA

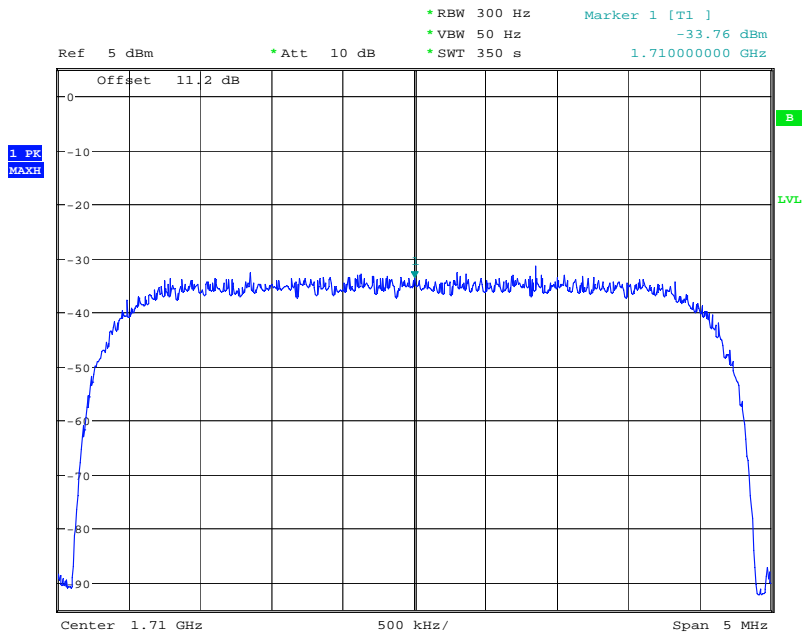

Date: 18.JUN.2008 11:52:46

Bottom channel 1710.0MHz Signal Generator only WCDMA

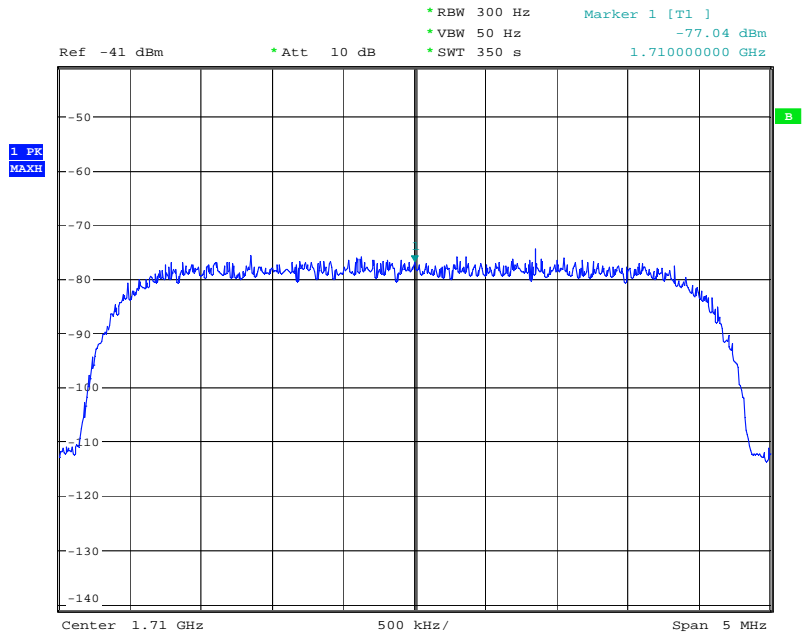

Date: 18.JUN.2008 12:35:34

The above plots depicting the output wavelshape show no measurable distortion visible when compared to the input signal.

Middle channel 1732.5MHz Signal Generator and EUT, WCDMA

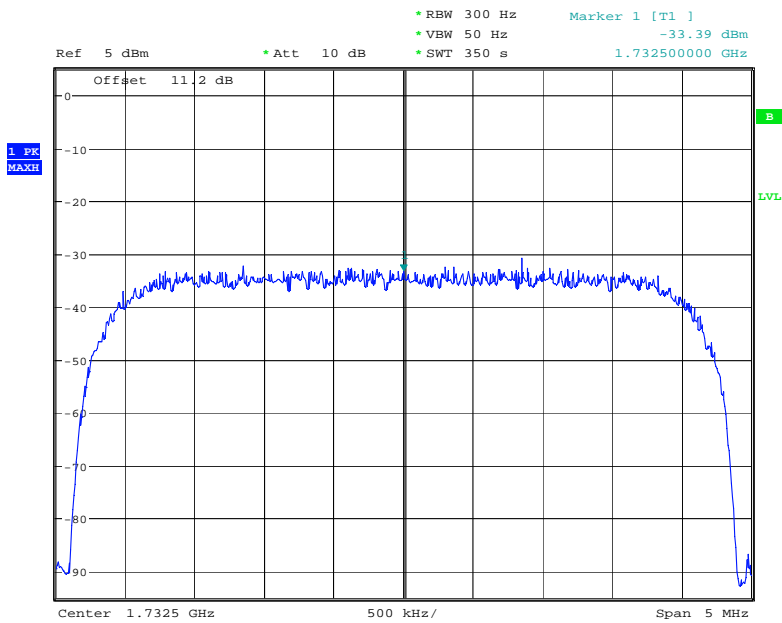

Date: 18.JUN.2008 12:05:43

Middle channel 1732.5MHz Signal Generator only WCDMA

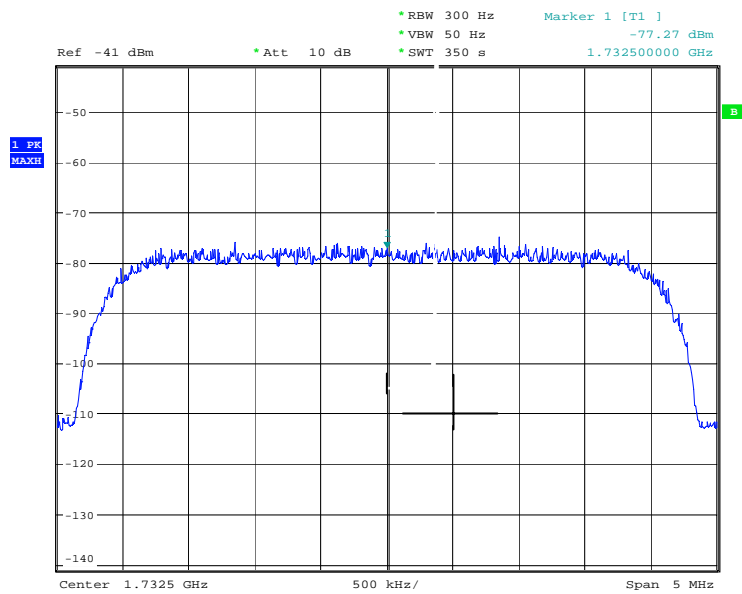

Date: 18.JUN.2008 13:40:23

Top channel 1755.0MHz Signal Generator and EUT, WCDMA

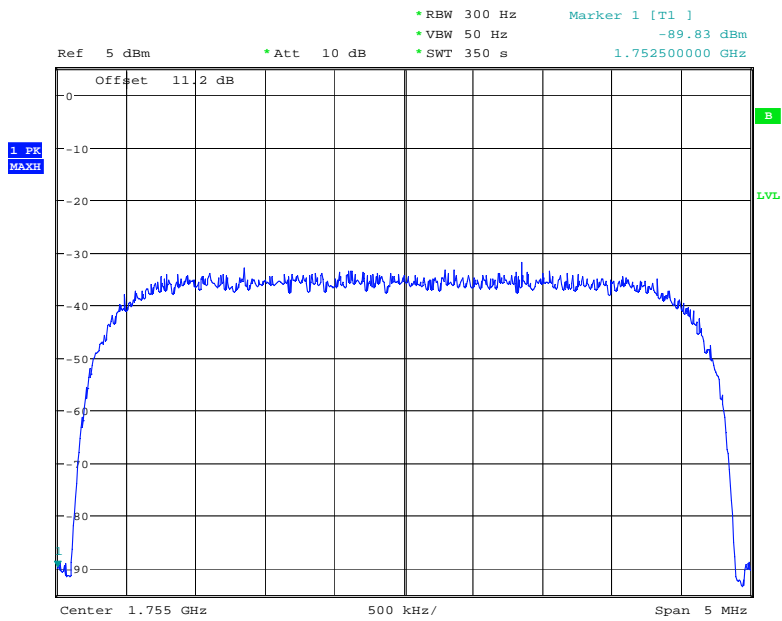

Date: 18.JUN.2008 12:18:22

Top channel 1755.0MHz Signal Generator only WCDMA

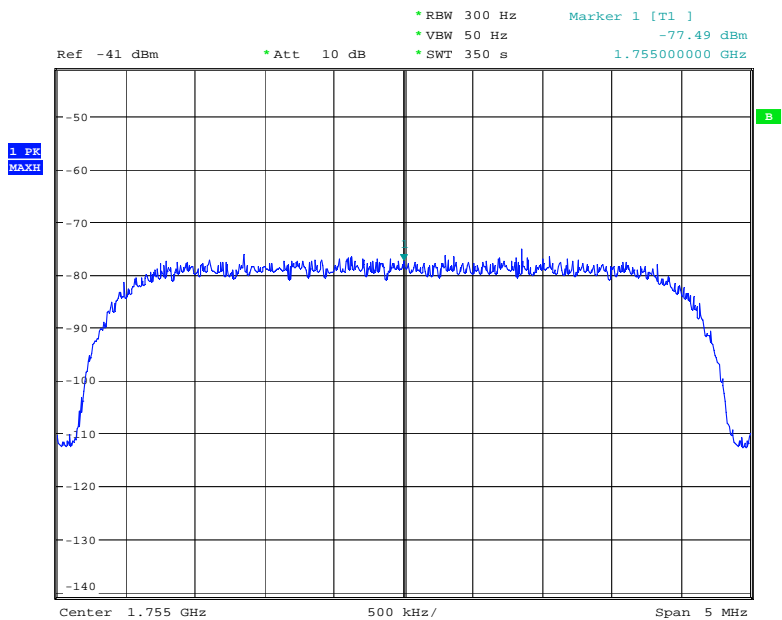

Date: 18.JUN.2008 14:03:34

TRANSMITTER TESTS

AMPLIFIER SPURIOUS EMISSIONS – CONDUCTED – Part 27.53 – UPLINK

Ambient temperature = 15°C
 Relative humidity = 44%
 Supply voltage = +24Vdc

Radio Laboratory Test Signal = F3E

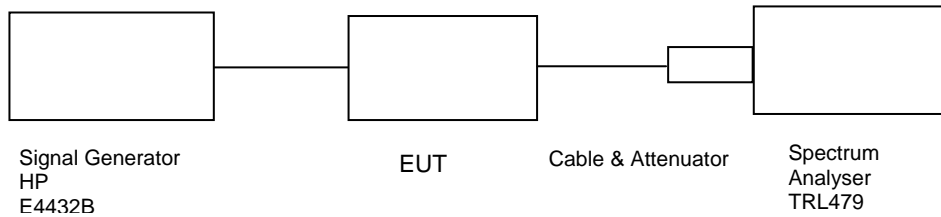

The test was set up as per the diagram. The level at the input was adjusted to compensate for the loss of the interconnecting cable. The unit was tested operating at maximum power and on three test frequencies.

The Spurious limit was calculated as follows:

On any frequency removed from the assigned frequency by more that 250% of the authorised bandwidth

At least 43 + 10 log PdB

$$(10\log P_{\text{watts}}) - (43+10\log (P_{\text{watts}} * 1000)) = \text{LIMIT} = -13 \text{ dBm}$$

RESULTS

FREQUENCY RANGE	FREQ. (MHz)	MEASURED LEVEL (dBm)	ATTENUATOR & CABLE LOSSES (dB)	EMISSION LEVEL (dBm)	LIMIT (dBm)
0Hz – 20GHz	No Significant Emissions Within 20 dB of the Limit				-13

The test equipment used for the Transmitter Conducted Emissions:

TYPE OF EQUIPMENT	MAKER/SUPPLIER	MODEL No	SERIAL No	TRL No	ACTUAL EQUIPMENT USED
SPECTRUM ANALYSER	Anritsu	MS2665C	MT26089	TRL479	X
ATTENUATOR	SPINNER	745357	D57224	225	X
ATTENUATOR	BIRD	8308-200-N	N/A	103	X
SIGNAL GENERATOR	HP	E4432B	GB38100116		X

Amplifier uplink

Conducted emissions bottom channel 1710.0MHz 30MHz – 1GHz

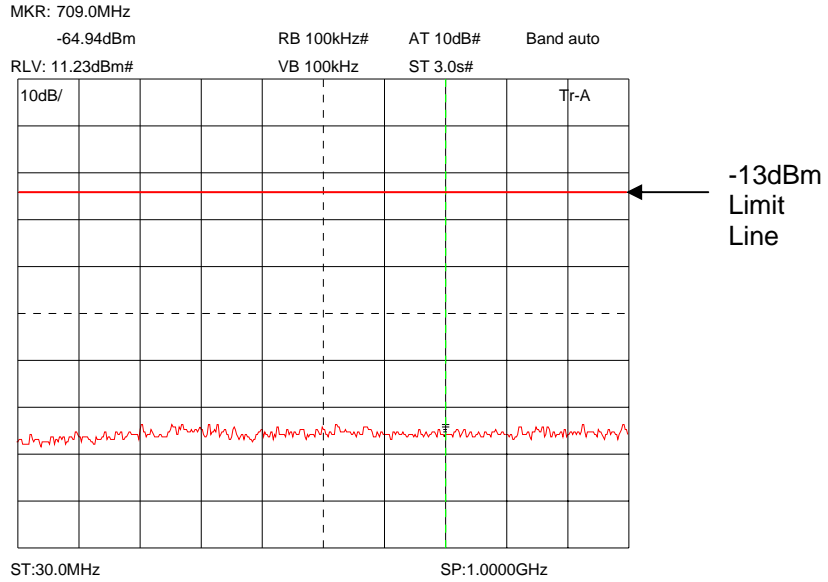

Conducted emissions bottom channel 1710.0MHz 1 – 5GHz

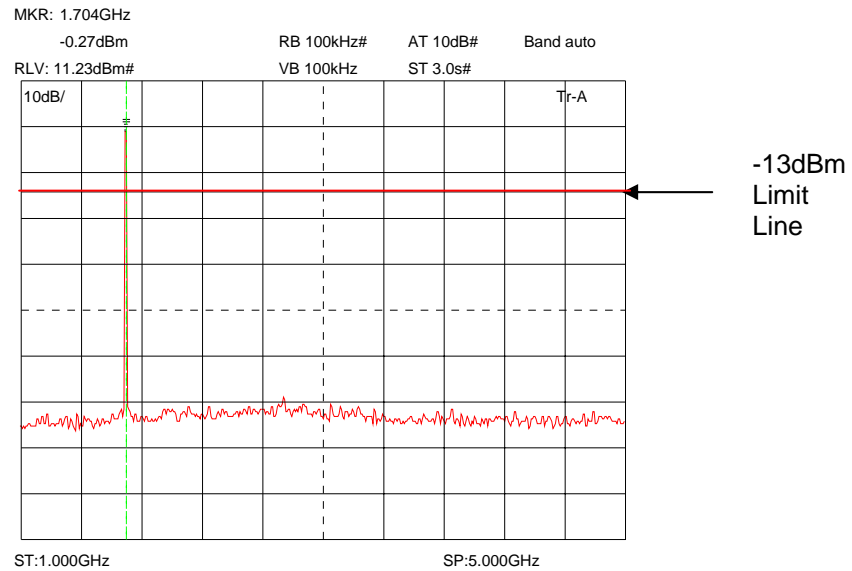

Conducted emissions bottom channel 1710.0MHz 15 – 20GHz

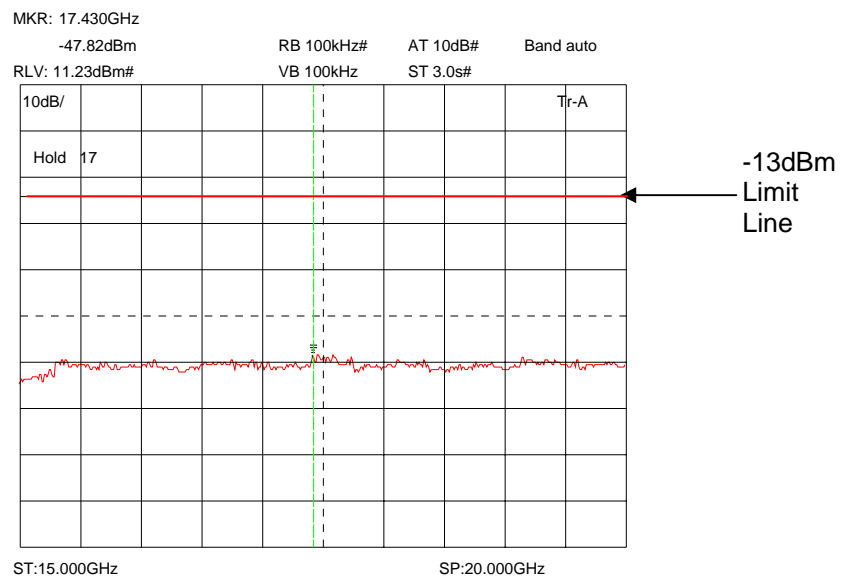

The above test results show that there were no emissions within 20dBs of the -13dBm limit.

Conducted emissions Mid channel 1732.5MHz 30MHz – 1GHz

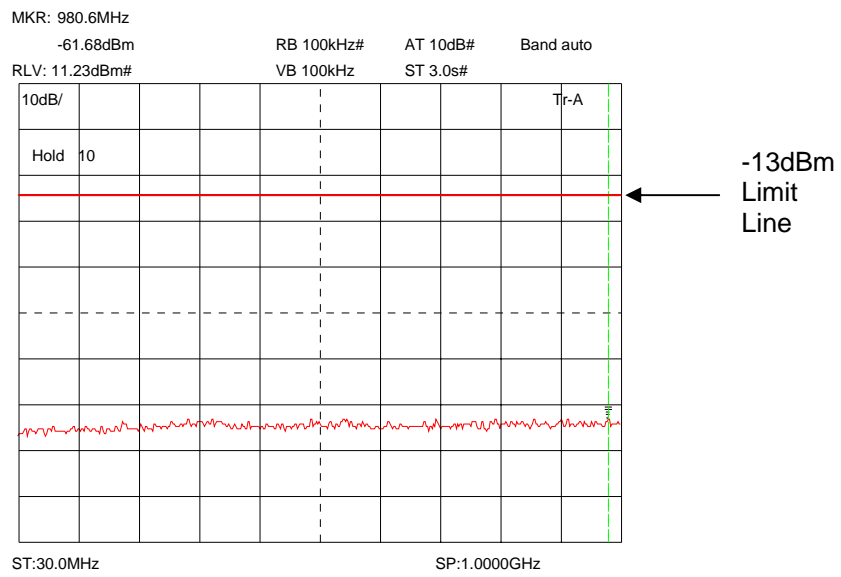

Conducted emissions Mid channel 1732.5MHz 1GHz – 5GHz

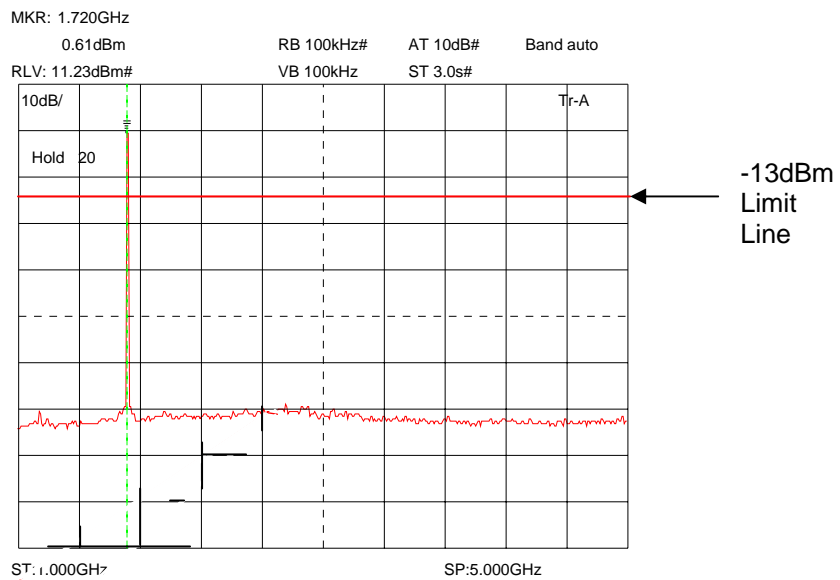

Conducted emissions Mid channel 1732.5MHz 5GHz – 10GHz

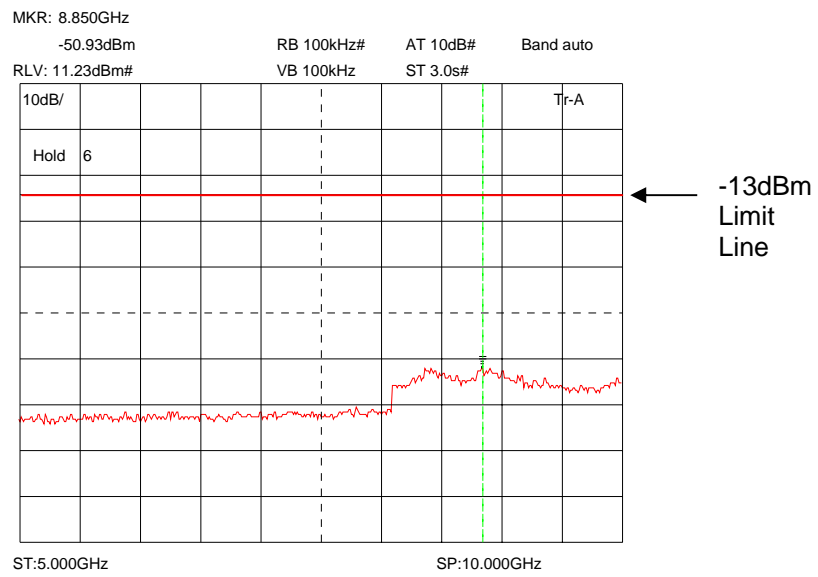

Conducted emissions Mid channel 1732.5MHz 10GHz – 15GHz

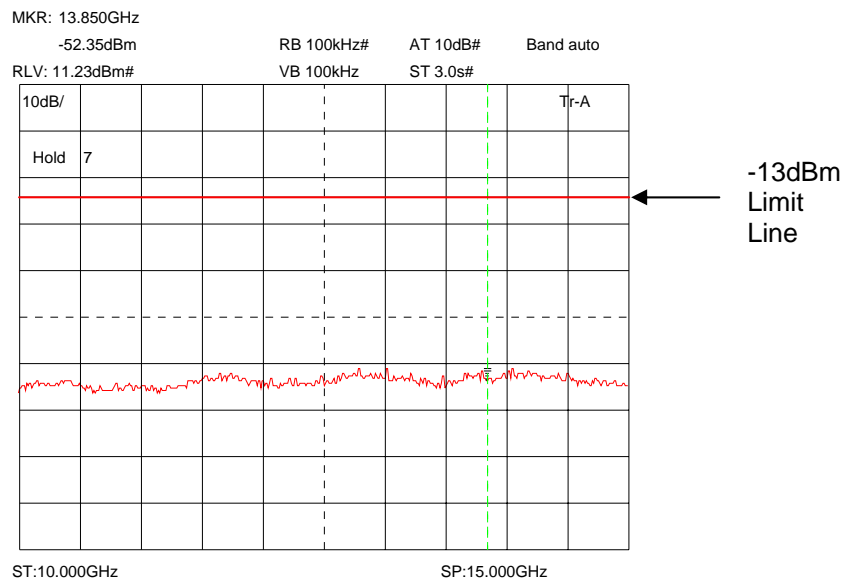

Conducted emissions Mid channel 1732.5MHz 15GHz – 20GHz

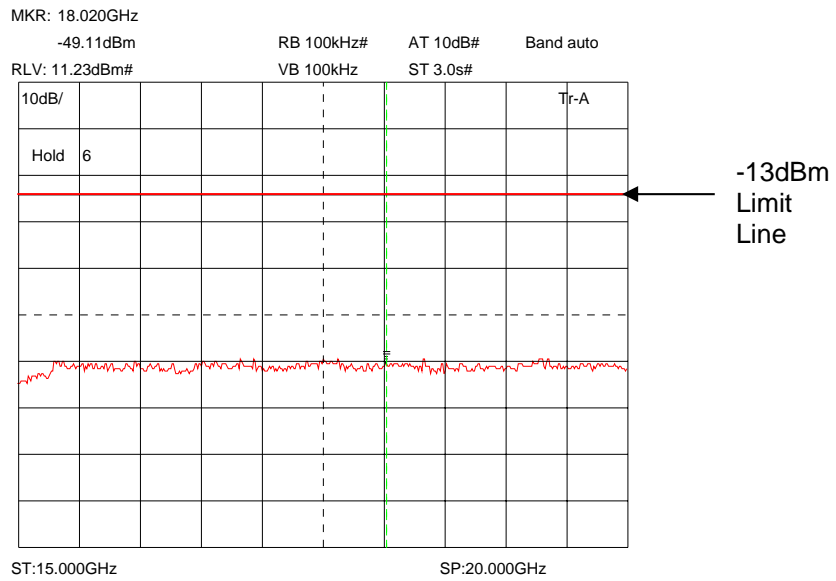

The above test results show that there were no emissions within 20dBs of the -13dBm limit

Conducted emissions Top channel 1755.0MHz 30MHz – 1GHz

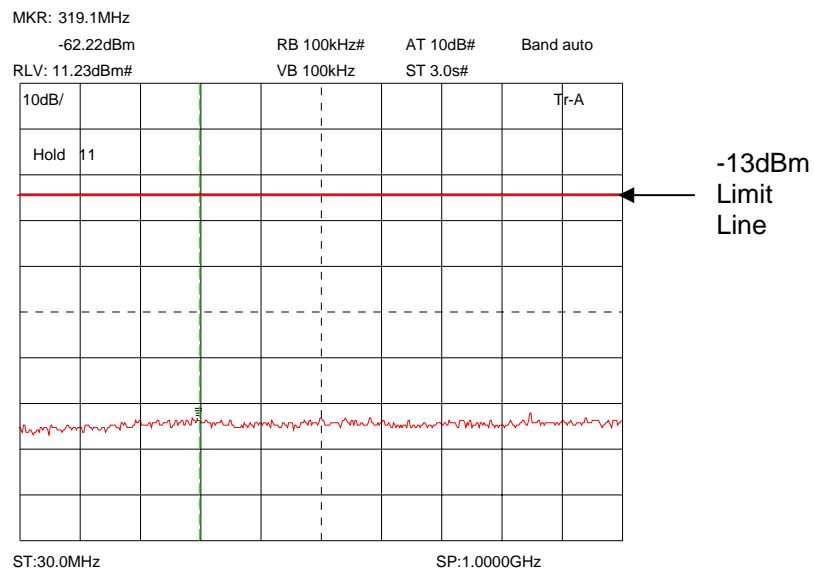

Conducted emissions Top channel 1755.0MHz 1GHz – 5GHz

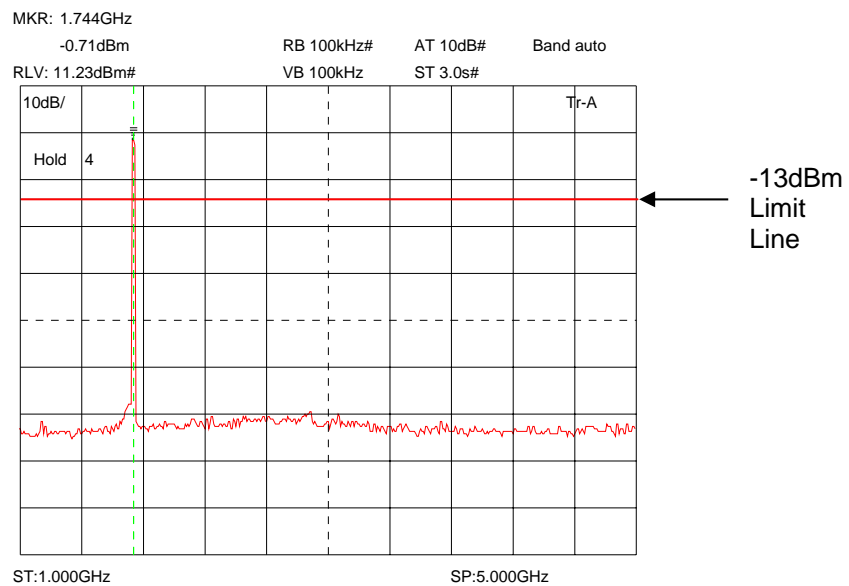

Conducted emissions Top channel 1755.0MHz 5GHz – 10GHz

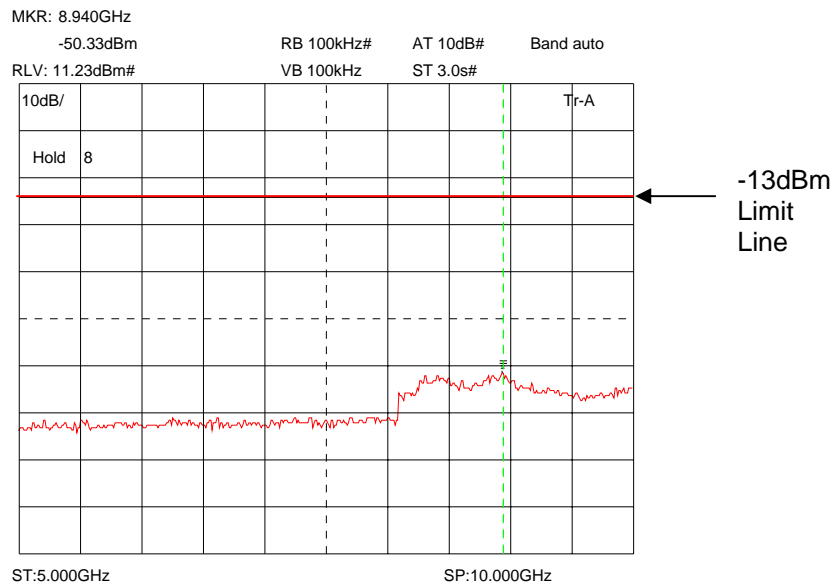

Conducted emissions Top channel 1755.0MHz 10GHz – 15GHz

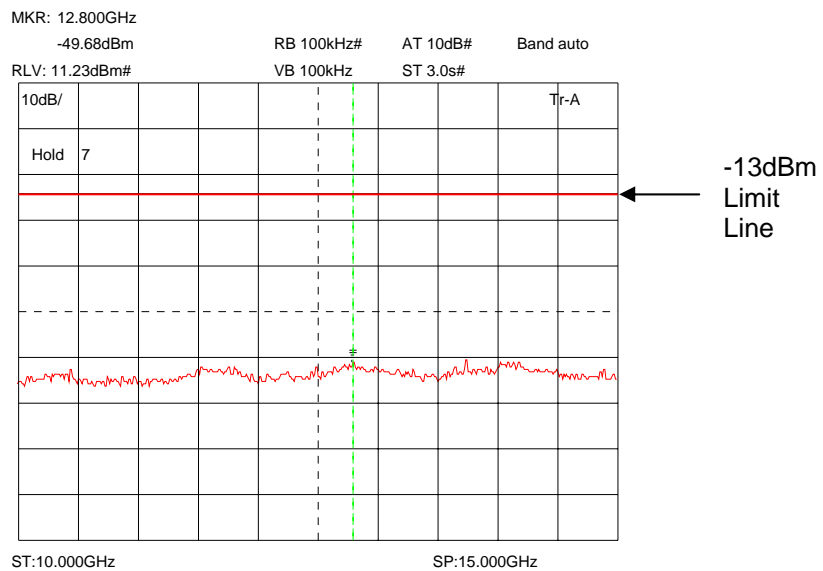

Conducted emissions Top channel 1755.0MHz 15GHz – 20GHz

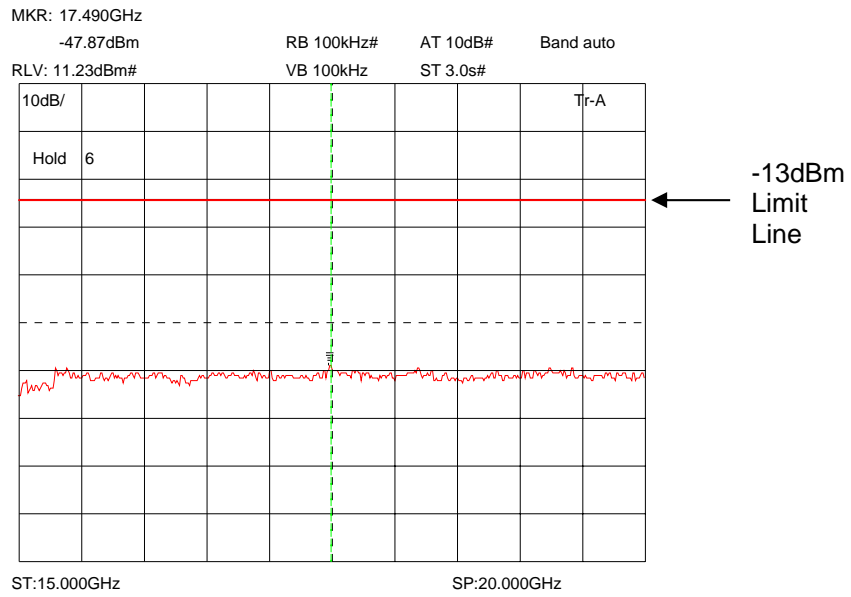

The above test results show that there were no emissions within 20dBs of the -13dBm limit

TRANSMITTER TESTS

AMPLIFIER SPURIOUS EMISSIONS – RADIATED – Part 27.53 – UPLINK

Ambient temperature = 15°C
 Relative humidity = 44%
 Conditions = OATS
 Supply voltage = +24Vdc
 Supply Frequency = N/A

Test Signal = F3E

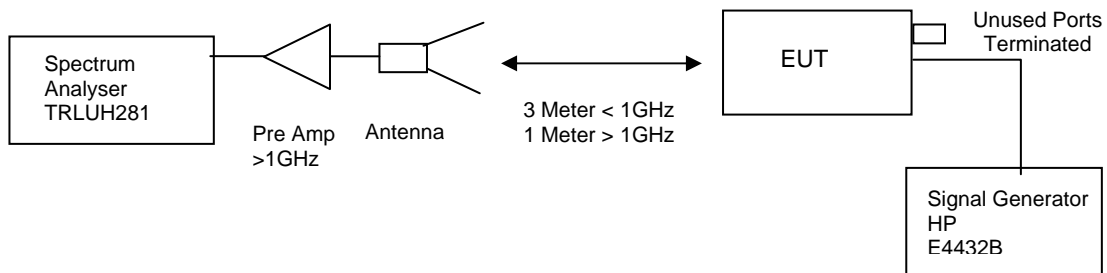

The test was set up as per the diagram. The level at the input was adjusted to compensate for the loss of the interconnecting cable. The unit was tested operating maximum power on three test frequencies with a 50 ohm load on the output. The unit was also tested with the signal generator replaced by another 50ohm load.

The Spurious limit was calculated as follows:

On any frequency removed from the assigned frequency by more that 250% of the authorised bandwidth

At least $43 + 10 \log P_{dB}$

$(10 \log P_{watts}) - (43 + 10 \log (P_{watts} * 1000)) = \text{LIMIT} = -13 \text{ dBm}$

RESULTS

FREQUENCY RANGE	FREQ. (MHz)	MEAS. Rx. (dBµV)	CABLE LOSS (dB)	ANT FACTOR	FIELD STRENGTH (dBµV/m)	CALCULATED EIRP (dBm)	LIMIT (dBm)
30MHz – 20GHz	No Significant Emissions Within 20 dB of the Limit						-13dBm

The test equipment used for the Transmitter Spurious Emissions:

TYPE OF EQUIPMENT	MAKER/SUPPLIER	MODEL No	SERIAL No	TRL No	ACTUAL EQUIPMENT USED
HORN	EMCO	3115	9010-3580	138	X
SPECTRUM ANALYSER	R&S	FSU46	200034	UH281	X
PRE AMPLIFIER	HP	8449B	3008A016	572	X
SIGNAL GENERATOR	HP	E4432B	GB38100116		X
ANTENNA	YORK	CBL611/A	1618	UH191	X
RECEIVER	R&S	ESVS10	825892/006	TRL04	X

E-Field Radiation (30MHz-1GHz)

EUT: Fibre Feed Remote Amplifier
Manuf: Axell Wireless
Op Cond: Prescan 30MHz - 1000MHz
Operator: S Hodgkinson
Test Spec: Part15
Comment: Tx bottom channel, uplink direction, permanent carrier, All ports terminated in 50 ohm loads. Unit lay horizontal terminals facing Rx antenna Vertical.

Scan Settings			(1 Range) Frequencies		Receiver Settings			
Start	Stop	Step	IF BW	Detector	M-Time	Atten	Preamp	OpRge
30MHz	1000MHz	50kHz	120kHz	PK	1msec	Auto	ON	60dB

Transducer	No.	Start	Stop	Name
1	21	30MHz	1000MHz	UH72
	22	30MHz	1000MHz	UH93

Final Measurement:	Detector:	X QP
	Meas Time:	2sec
	Subranges:	50
	Acc Margin:	10 dB

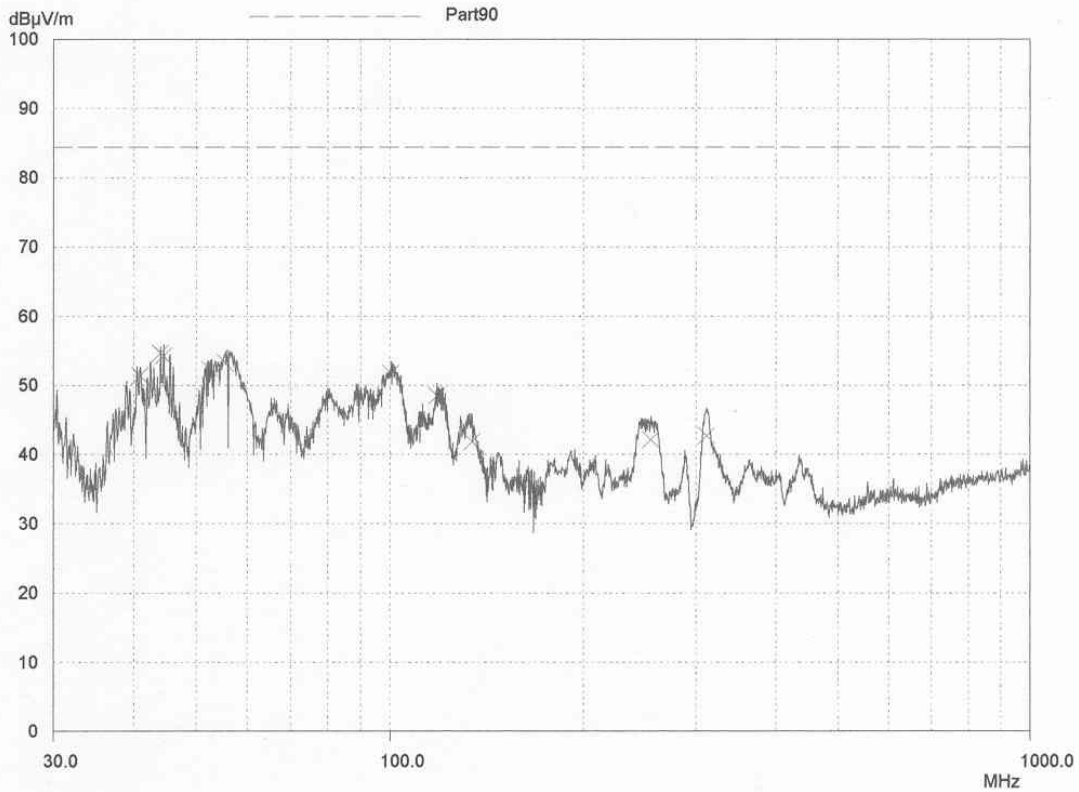

E-Field Radiation (30MHz-1GHz)

EUT: Fibre Feed Remote Amplifier
 Manuf: Axell Wireless
 Op Cond: Prescan 30MHz - 1000MHz
 Operator: S Hodgkinson
 Test Spec: Part15
 Comment: Tx middle channel, uplink direction, permanent carrier, All ports terminated in 50 ohm loads. Unit lay horizontal terminals facing I Rx antenna Vertical.

Scan Settings			(1 Range) Frequencies		Receiver Settings			
Start	Stop	Step	IF BW	Detector	M-Time	Atten	Preamp	OpRge
30MHz	1000MHz	50kHz	120kHz	PK	1msec	Auto	ON	60dB

Transducer	No.	Start	Stop	Name
1	21	30MHz	1000MHz	UH72
	22	30MHz	1000MHz	UH93

Prescan Measurement: Detector: X PK
 Meas Time: see scan settings
 Subranges: 50
 Acc Margin: 10 dB

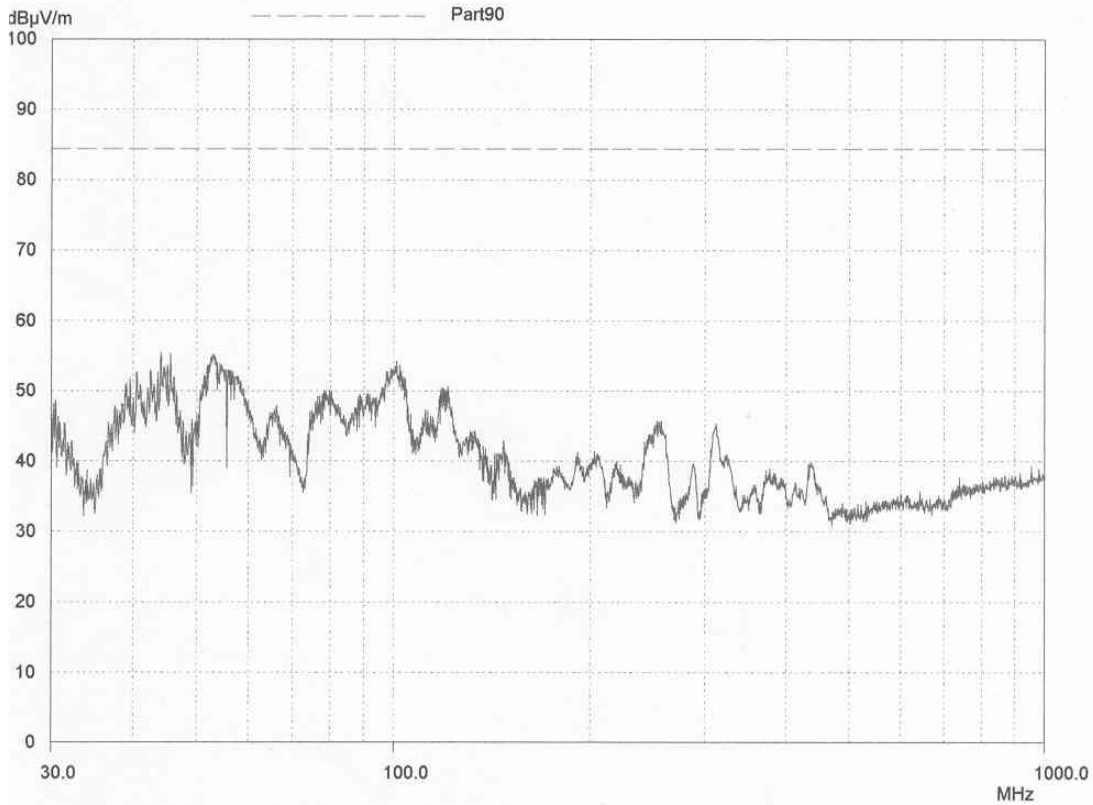

E-Field Radiation (30MHz-1GHz)

EUT: Fibre Feed Remote Amplifier
 Manuf: Axell Wireless
 Op Cond: Prescan 30MHz - 1000MHz
 Operator: S Hodgkinson
 Test Spec: Part15
 Comment: Tx top channel, uplink direction, permanent carrier, All ports terminated in 50 ohm loads. Unit lay horizontal terminals facing Rx antenna. Rx antenna Vertical.

Scan Settings (1 Range)				Receiver Settings				
Frequencies		Step	IF BW	Detector	M-Time	Atten	Preamp	OpRge
Start	Stop							
30MHz	1000MHz	50kHz	120kHz	PK	1msec	Auto	ON	60dB

Transducer	No.	Start	Stop	Name
1	21	30MHz	1000MHz	UH72
	22	30MHz	1000MHz	UH93

Prescan Measurement: Detector: X PK
 Meas Time: see scan settings
 Subranges: 50
 Acc Margin: 10 dB

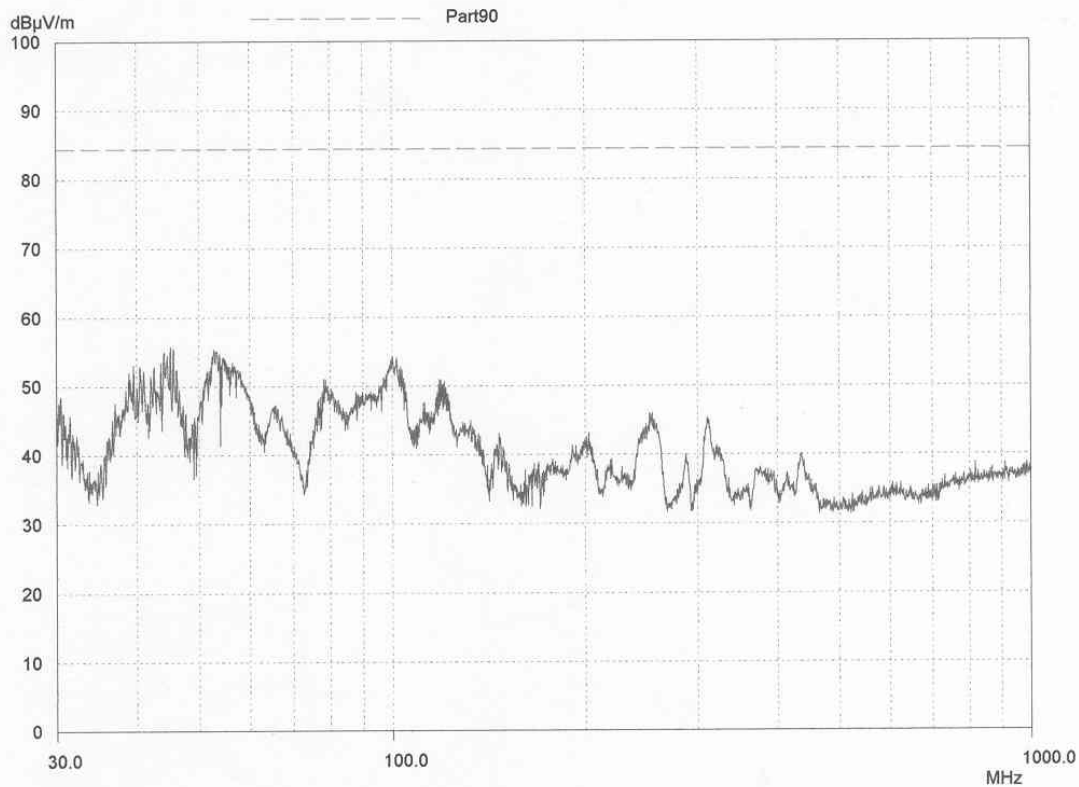

Radiated emissions bottom channel 1710.0MHz 1 - 5GHz

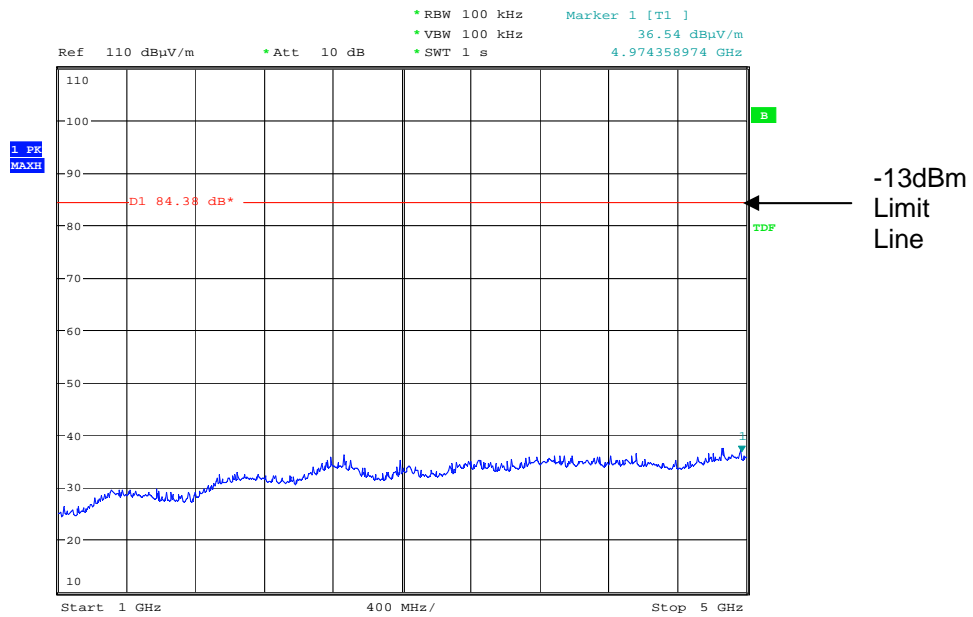

Date: 19.JUN.2008 11:06:24

Radiated emissions bottom channel 1710.0MHz 5 - 10GHz

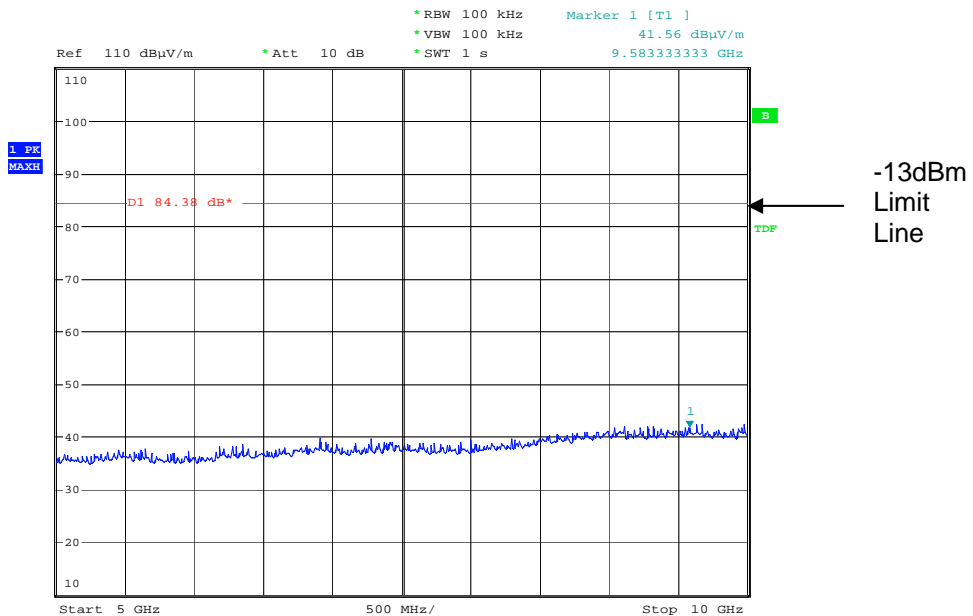

Date: 19.JUN.2008 11:07:03

Radiated emissions bottom channel 1710.0MHz 10 -15GHz

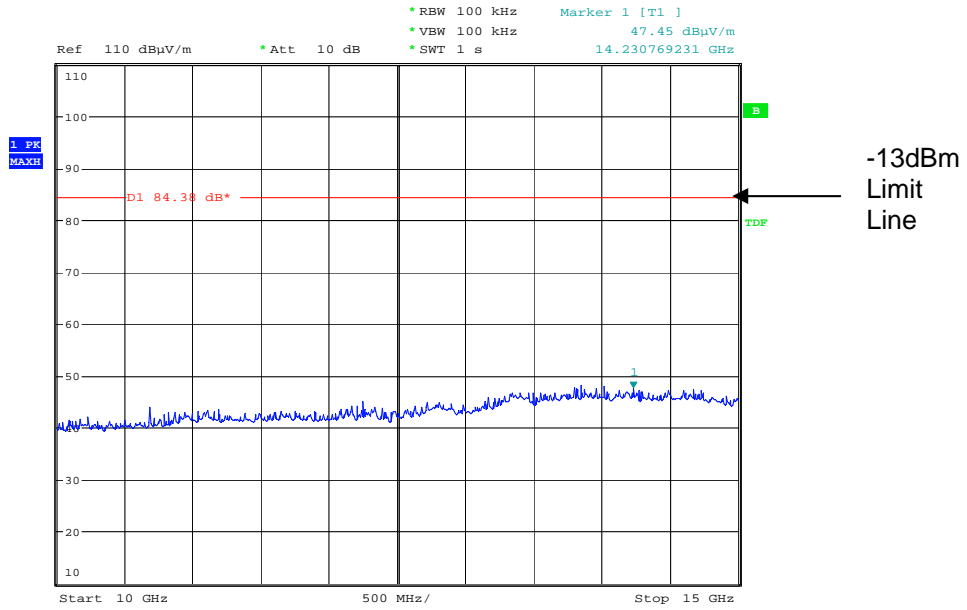

Date: 19.JUN.2008 11:07:32

Radiated emissions bottom channel 1710.0MHz 15 -18GHz

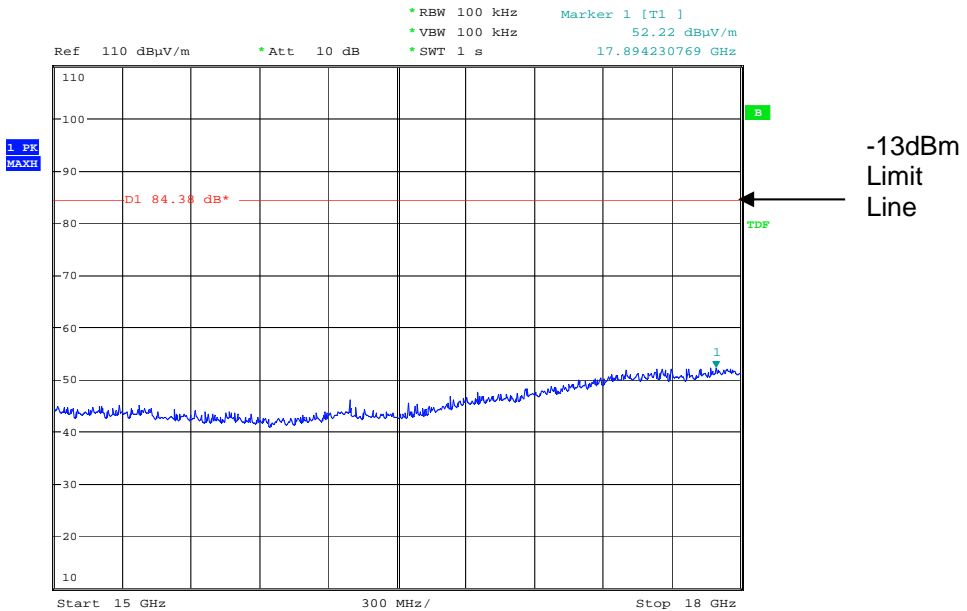

Date: 19.JUN.2008 11:08:21

The above test results show that there were no emissions within 20dBs of the -13dBm limit.

Radiated emissions middle channel 1732.5MHz 1 - 5GHz

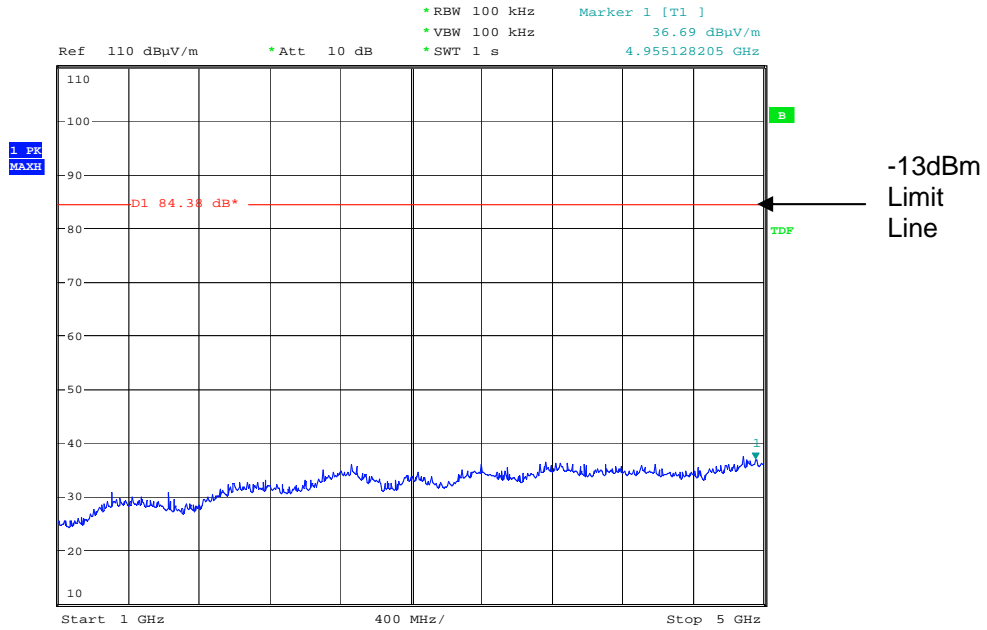

Date: 19.JUN.2008 11:29:12

Radiated emissions middle channel 1732.5MHz 5 - 10GHz

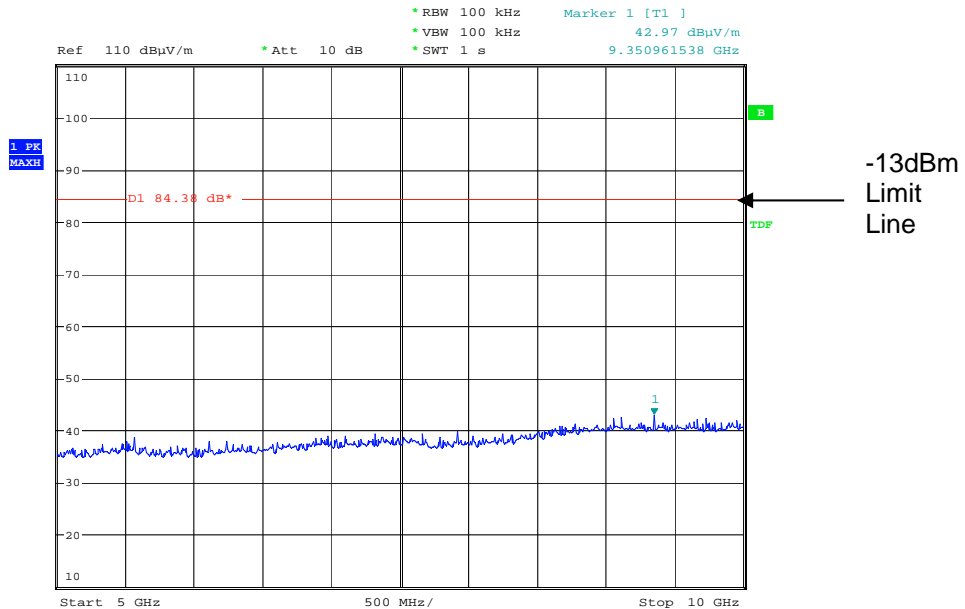

Date: 19.JUN.2008 11:30:01

Radiated emissions middle channel 1732.5MHz 10 - 15GHz

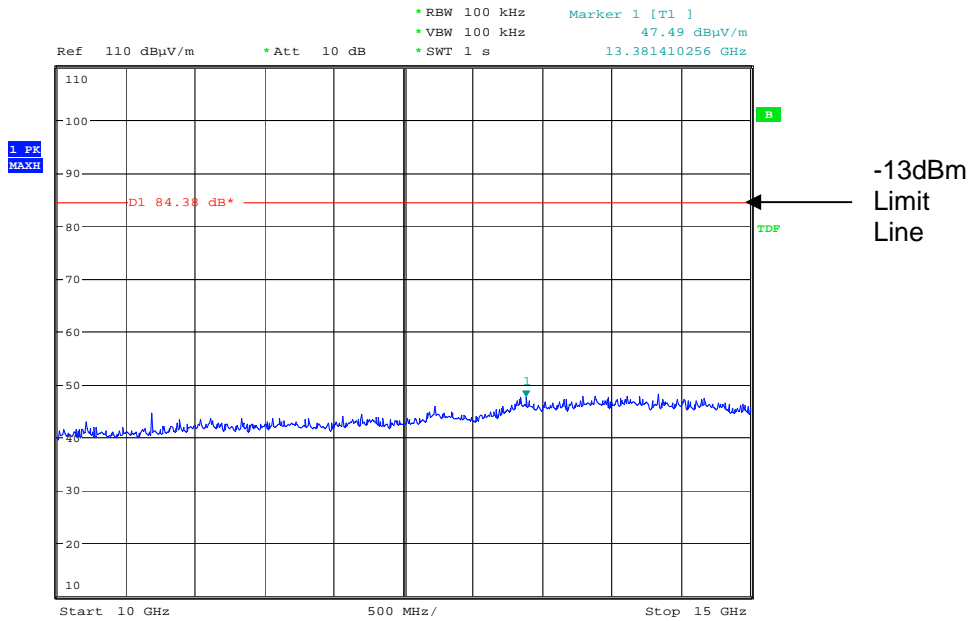

Date: 19.JUN.2008 11:31:02

Radiated emissions middle channel 1732.5MHz 15 - 18GHz

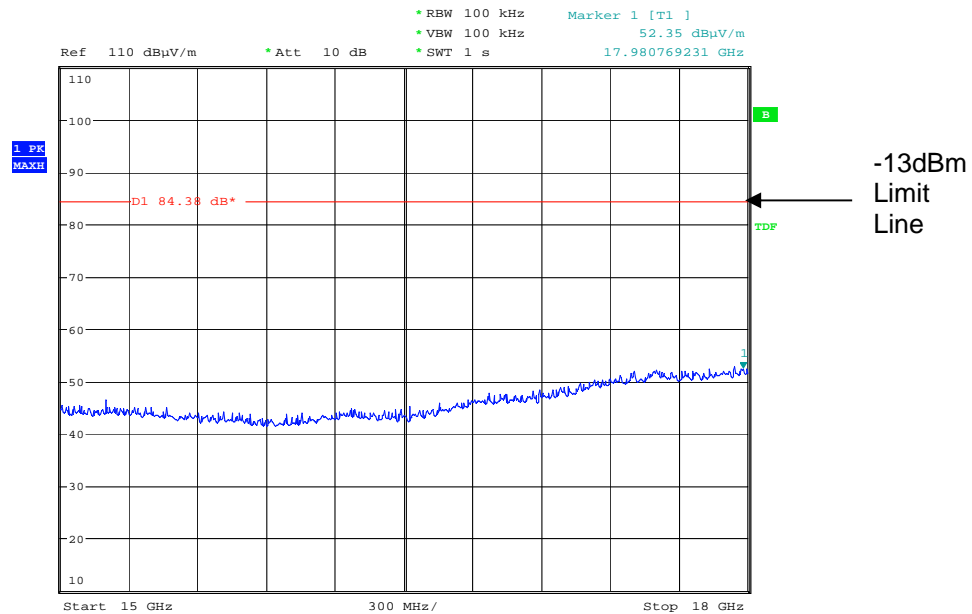

Date: 19.JUN.2008 11:31:52

The above test results show that there were no emissions within 20dBs of the -13dBm limit.

Radiated emissions top channel 1755.0 MHz 1 - 5GHz

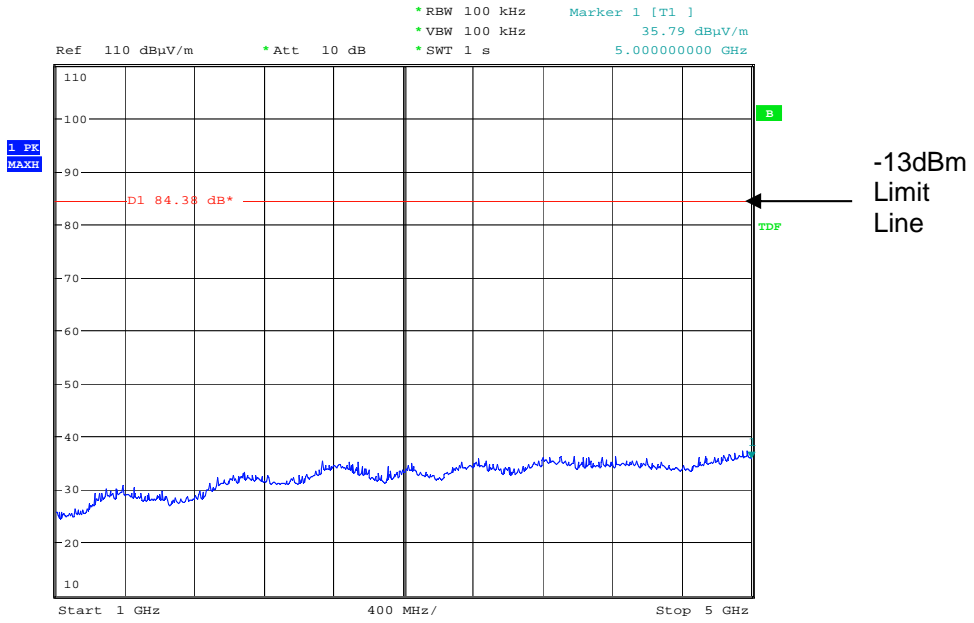

Date: 19.JUN.2008 11:39:15

Radiated emissions top channel 1755.0 MHz 5 - 10GHz

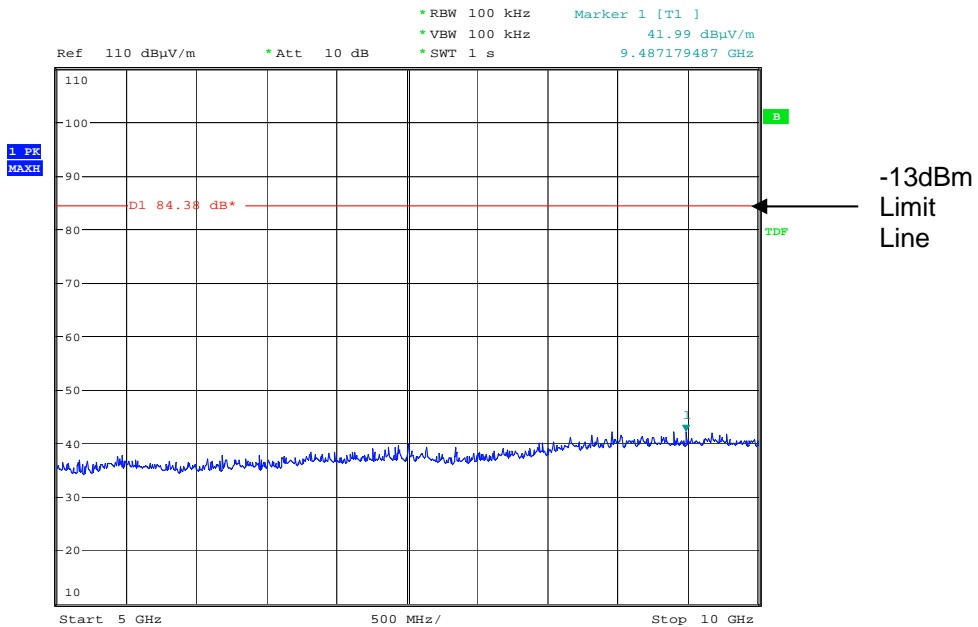

Date: 19.JUN.2008 11:39:40

Radiated emissions top channel 1755.0 MHz 10 - 15GHz

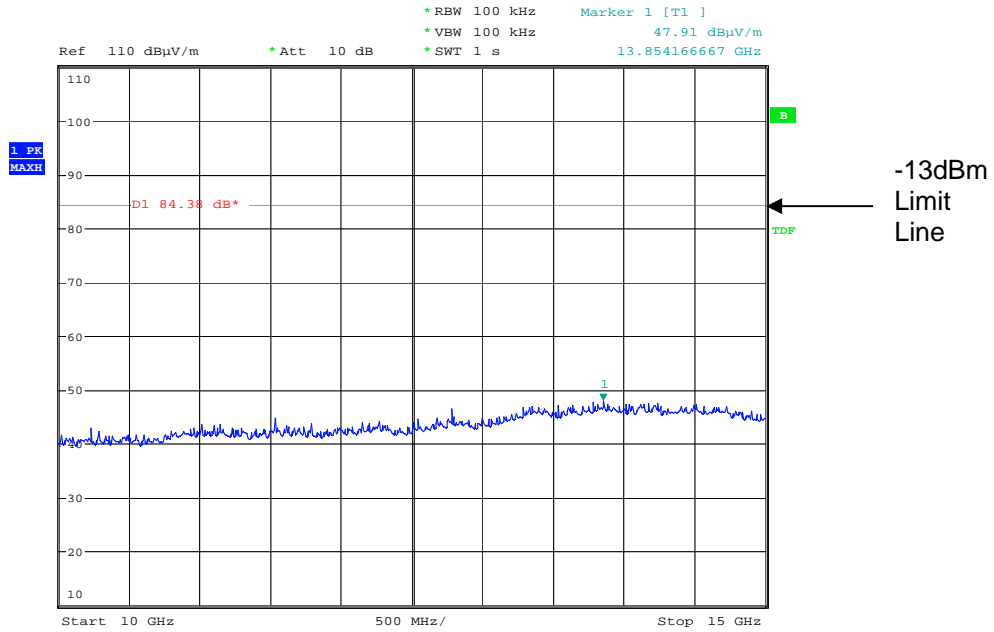

Date: 19.JUN.2008 11:41:12

Radiated emissions top channel 1755.0 MHz 15 - 18GHz

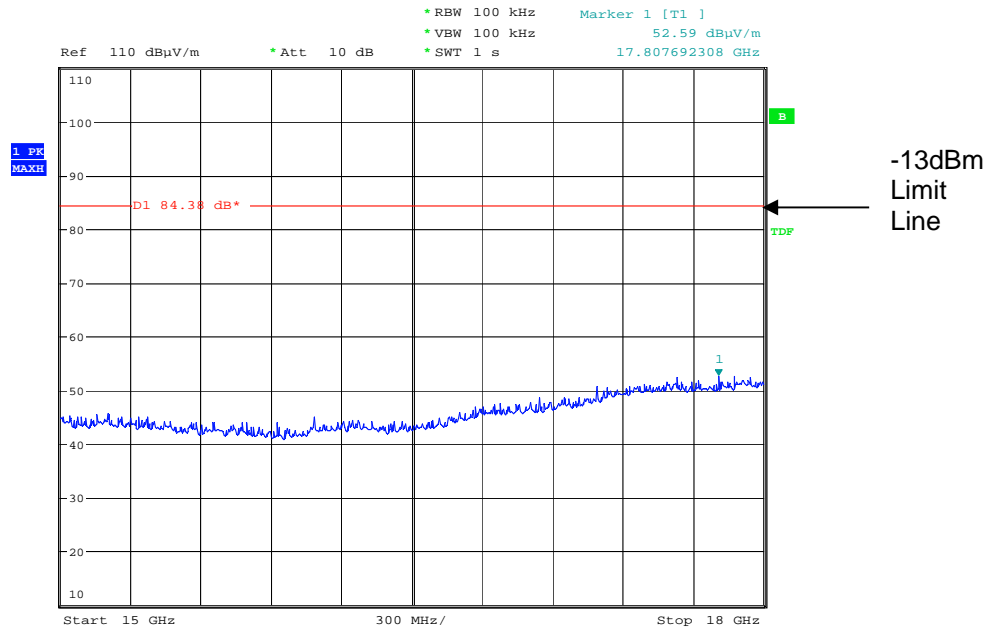

Date: 19.JUN.2008 11:41:47

The above test results show that there were no emissions within 20dBs of the -13dBm limit.

AMPLIFIER GAIN – CONDUCTED – Part 27.55 – DOWNLINK

Ambient temperature = 23°C
 Relative humidity = 48%
 Supply voltage = +24Vdc
 Channel number = See test results

Radio Laboratory

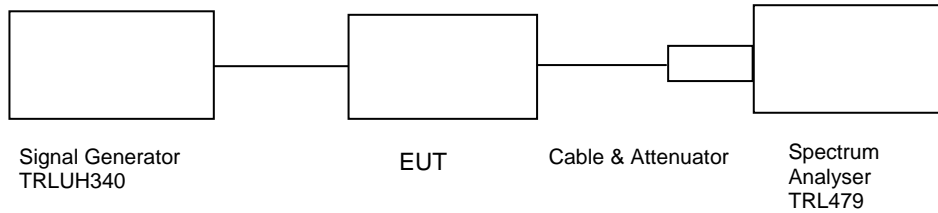

Frequency MHz	Signal Generator input level dBm	Input Cable Loss dB	Output Cable & Attenuator loss dB	Level at Spectrum Analyser dBm	Gain dB	Conducted Output Power dBm	Gain after 10dB input level increase dB
2110.0	-21.10	1.27	40.23	-9.55	53.05	30.68	43.04
2132.5	-20.70	1.27	40.23	-7.28	54.92	32.95	45.19
2155.0	-21.50	1.27	40.23	-8.56	54.44	31.67	44.44

Notes: 1. The signal generator input was increased by 10dBs and the level of the output signal remeasured.

TYPE OF EQUIPMENT	MAKER/SUPPLIER	MODEL No	SERIAL No	TRL No	ACTUAL EQUIPMENT USED
SPECTRUM ANALYSER	Anritsu	MS2665C	MT26089	TRL479	X
ATTENUATOR	BIRD	8308-200-N	N/A	103	X
ATTENUATOR	SPINNER	745357	D57224	225	X
SIGNAL GENERATOR	HP	83630B	3722A00588	UH340	X

AMPLIFIER INTERMODULATION SPURIOUS EMISSIONS – CONDUCTED – Part 27.53– UPLINK

Ambient temperature = 24°C
 Relative humidity = 44%
 Supply voltage = +24Vdc

Radio Laboratory

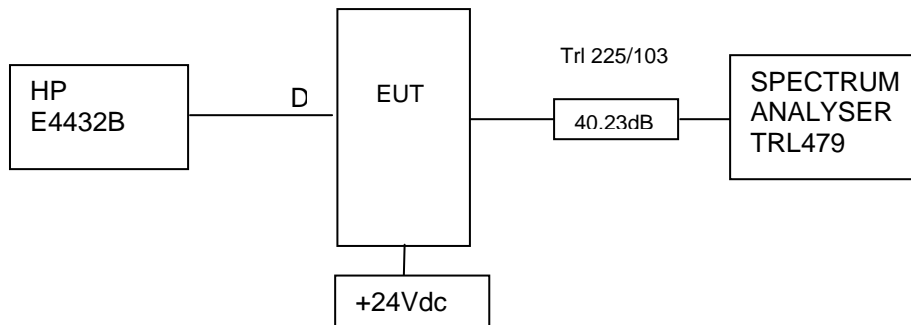

The intermodulation and spurious products were measured with the amplifier operating at maximum gain. A three tone test was conducted using the equipment as above. The input power level was adjusted so the level at point D was 10dB above the maximum input of -20.70dBm. The cable and attenuator loss between the EUT and the spectrum analyser was 40.23dB.

RF Input Frequency (MHz)			Highest Intermodulation Product Level (dBm)	Limit (dBm)
2140.0	2147.5	2155.0	-25.09dBm@ 2111.7MHz	-13

Sweep data is shown on the next page:

Test equipment used for intermodulation test

TYPE OF EQUIPMENT	MAKER/SUPPLIER	MODEL No	SERIAL No	TRL No	ACTUAL EQUIPMENT USED
SPECTRUM ANALYSER	Anritsu	MS2665C	MT26089	TRL479	X
ATTENUATOR	BIRD	8308-200-N	N/A	103	X
ATTENUATOR	SPINNER	745357	D57224	225	X
SIGNAL GENERATOR	HP	E4432B	GB38100116		X

Intermodulation Inband

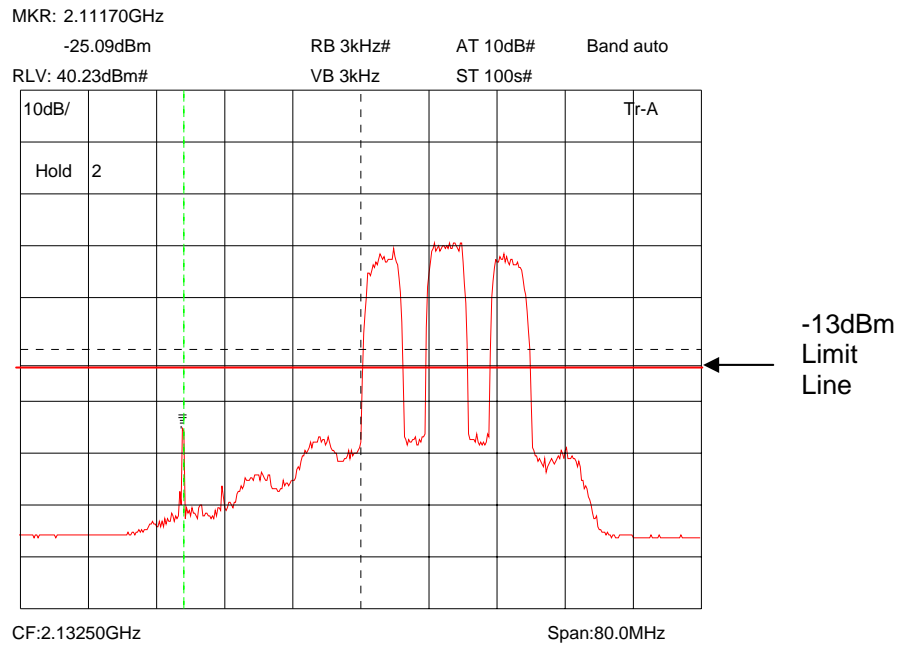

The above plot shows that all products (designated by ☆) are below the spurious limit

Intermodulation Wideband

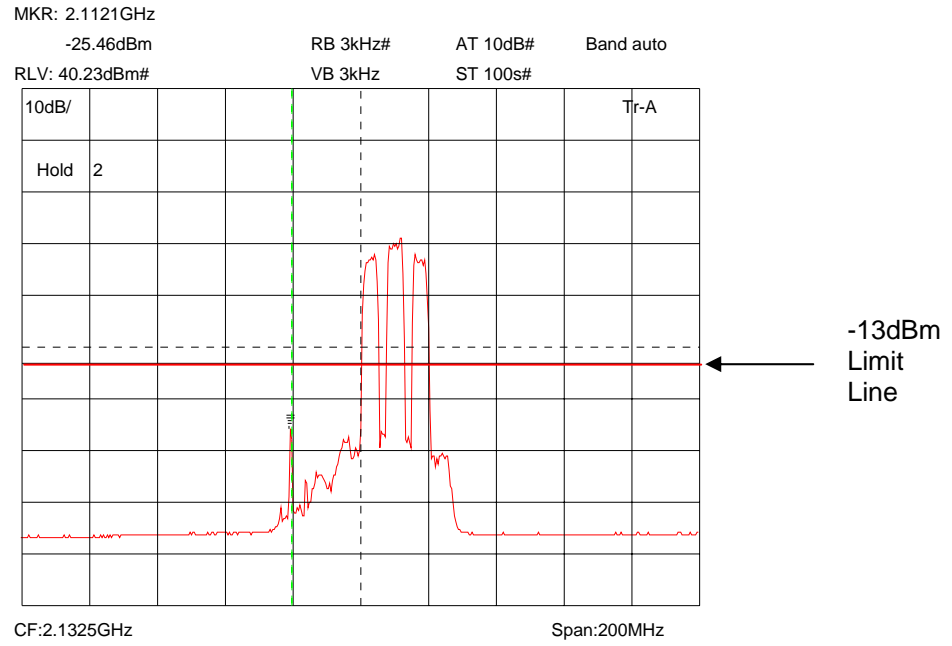

The above plot shows that there are no products outside the bands.

Intermodulation Wideband

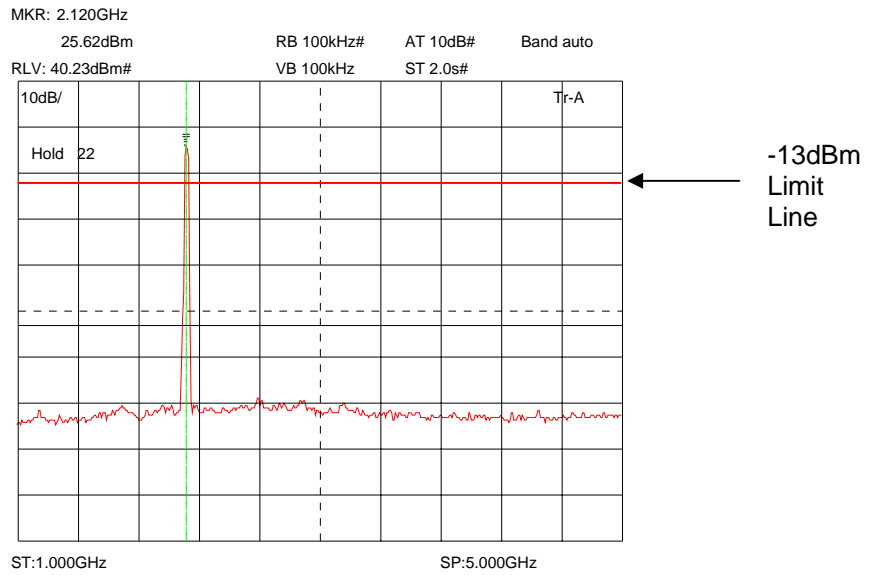
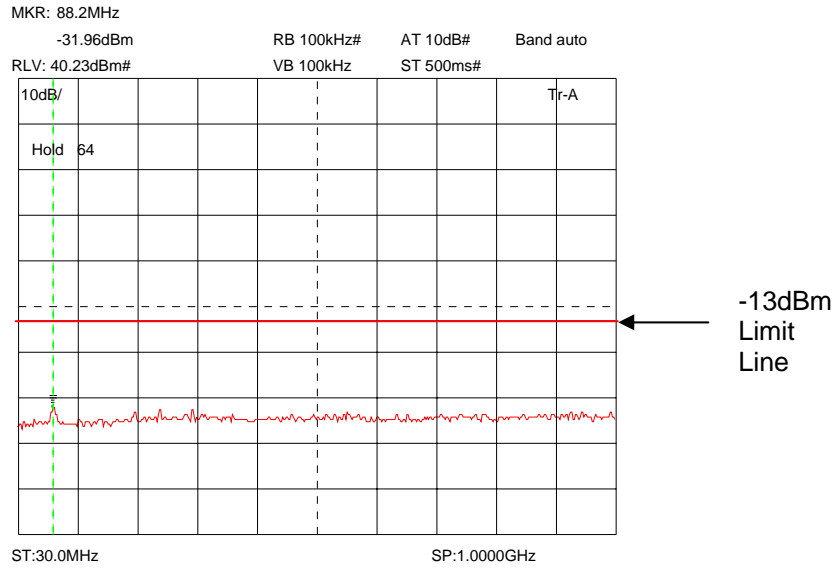

Intermodulation Wideband

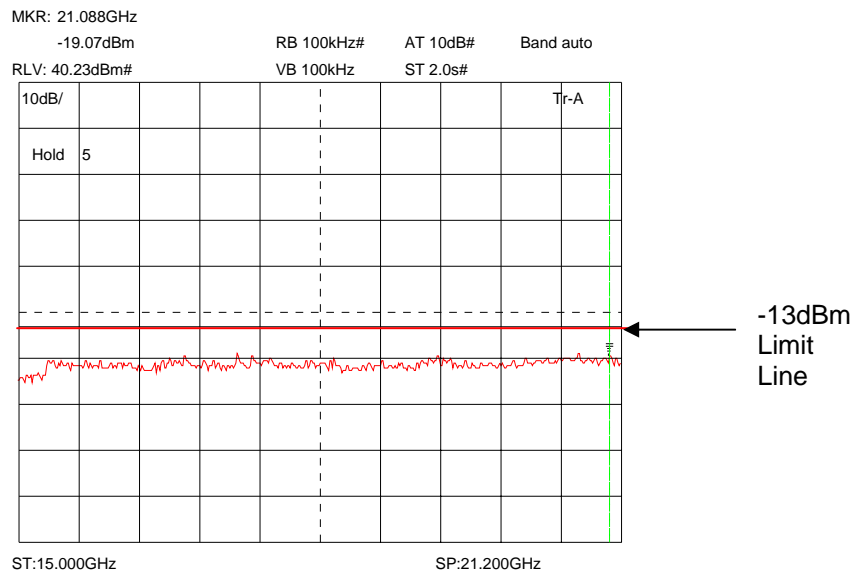

The above plots shows that there are no products outside the bands.

TRANSMITTER TESTS

AMPLIFIER MODULATED CHANNEL TEST – CONDUCTED – Part 27.53 – DOWNLINK

Ambient temperature = 15°C Radio Laboratory
 Relative humidity = 44%
 Supply voltage = +24Vdc
 Channel number = See test results

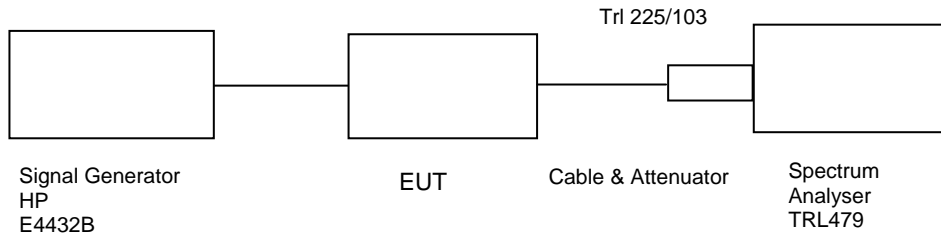

This test was performed to show that the amplifier does not alter the input signal in any way. The input signal was set to the maximum input level (-11.1dBm) and modulated with a WCDMA tone. The plots show the signal measured at the signal generator and the signal measured at the output of the EUT.

Note: The cables and attenuators had the following losses.

1. Cable and attenuator between EUT and spectrum analyser 40.23dB
2. Cable between signal generator and EUT 1.27dB

TYPE OF EQUIPMENT	MAKER/SUPPLIER	MODEL No	SERIAL No	TRL No	ACTUAL EQUIPMENT USED
SPECTRUM ANALYSER	Anritsu	MS2665C	MT26089	TRL479	X
ATTENUATOR	SPINNER	745357	D57224	225	X
ATTENUATOR	BIRD	8308-200-N	N/A	103	X
SIGNAL GENERATOR	MARCONI	2042	119562/021	254	
SIGNAL GENERATOR	HP	E4432B	GB38100116		X

Amplifier downlink

Bottom channel 2110.0MHz Signal Generator and EUT, WCDMA

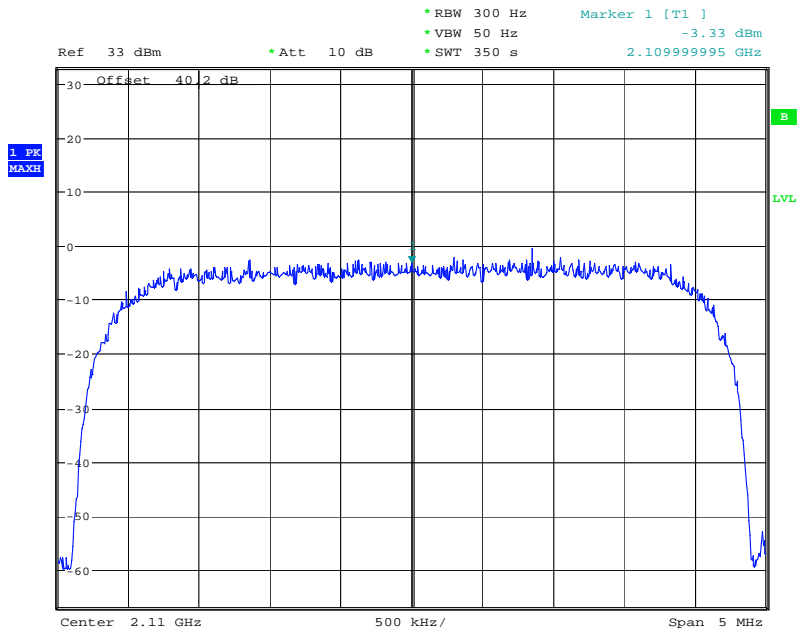

Date: 18.JUN.2008 09:43:58

Bottom channel 2110.0MHz Signal Generator, WCDMA

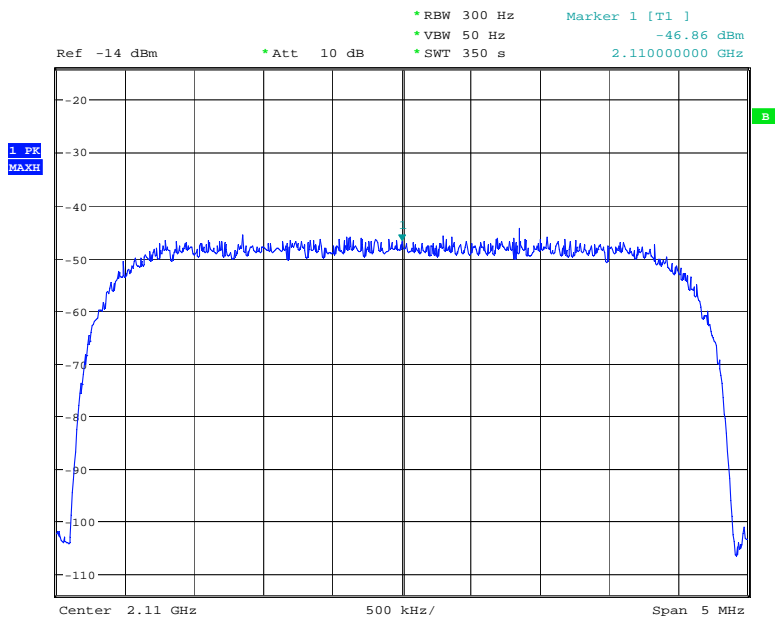

Date: 18.JUN.2008 10:55:56

The above plots depicting the output wavelshape show no measurable distortion visible when compared to the input signal.

Middle channel 2132.5MHz Signal Generator and EUT, WCDMA

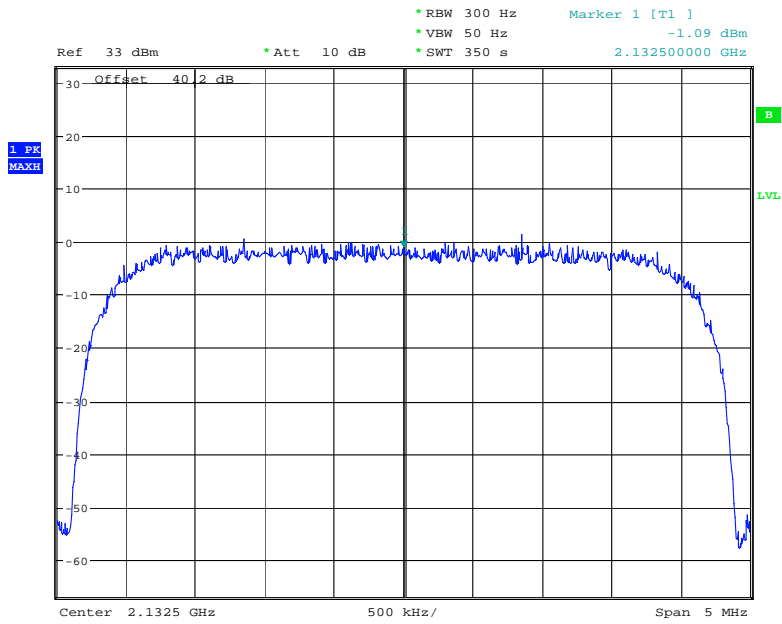

Date: 18.JUN.2008 10:38:23

Middle channel 2132.5MHz Signal Generator, WCDMA

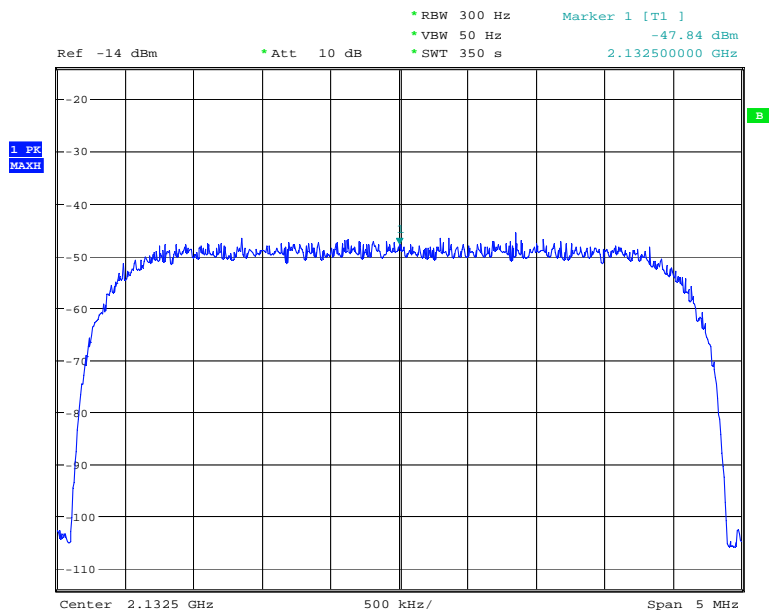

Date: 18.JUN.2008 11:09:37

The above plots depicting the output waveshape show no measurable distortion visible when compared to the input signal.

TRANSMITTER TESTS

AMPLIFIER SPURIOUS EMISSIONS – CONDUCTED – Part 27.53 – DOWNLINK

Ambient temperature = 15°C
 Relative humidity = 44%
 Supply voltage = +24Vdc

Radio Laboratory Test Signal = F3E

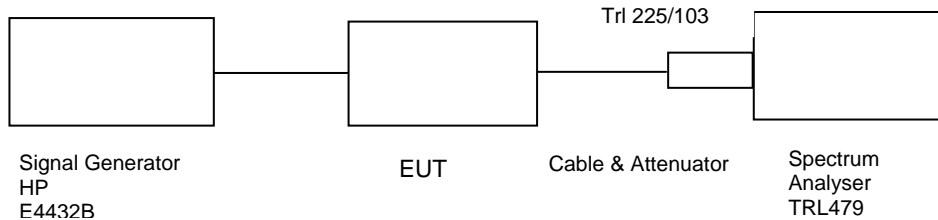

The test was set up as per the diagram. The level at the input was adjusted to compensate for the loss of the interconnecting cable. The unit was tested operating at maximum power and on three test frequencies.

The Spurious limit was calculated as follows:

On any frequency removed from the assigned frequency by more that 250% of the authorised bandwidth

At least 43 + 10 log PdB

$(10\log P_{\text{watts}}) - (43 + 10\log (P_{\text{watts}} * 1000)) = \text{LIMIT} = -13 \text{ dBm}$

Note: The cables and attenuators had the following losses.

1. Cable and attenuator between EUT and spectrum analyser 40.23dB
2. Cable between signal generator and EUT 1.27dB

RESULTS

FREQUENCY RANGE	FREQ. (MHz)	EMISSION LEVEL (dBm)	LIMIT (dBm)
Bottom Channel 2110.0MHz	54.6488MHz	-31.03dBm	-13dBm
Middle Channel 2132.5MHz	77.1500MHz	-27.02dBm	
Top Channel 2155.0MHz	99.6610MHz	-29.03dBm	

The test equipment used for the Transmitter Conducted Emissions:

TYPE OF EQUIPMENT	MAKER/SUPPLIER	MODEL No	SERIAL No	TRL No	ACTUAL EQUIPMENT USED
SPECTRUM ANALYSER	Anritsu	MS2665C	MT26089	TRL479	X
ATTENUATOR	SPINNER	745357	D57224	225	X
ATTENUATOR	BIRD	8308-200-N	N/A	103	X
SIGNAL GENERATOR	HP	E4432B	GB38100116		X

Amplifier Downlink

Conducted emissions bottom channel 2110.0MHz 30MHz – 1GHz

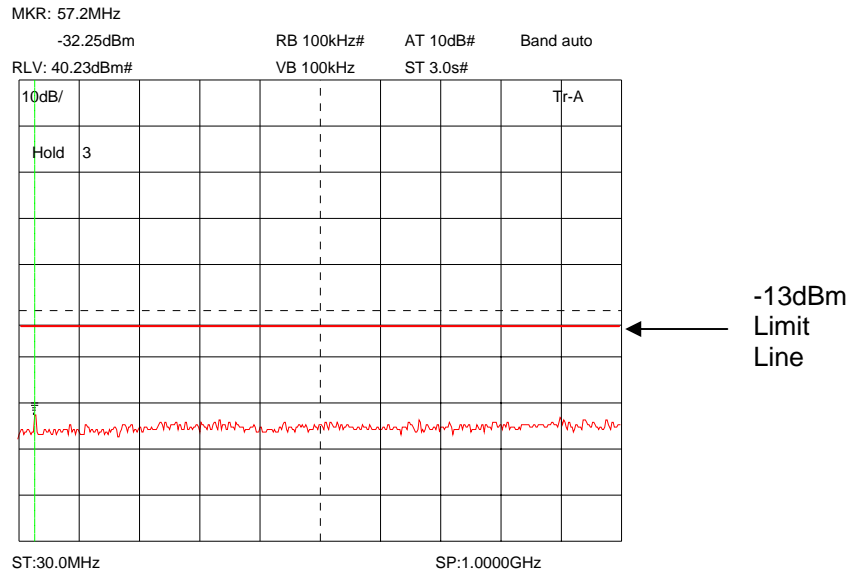

Conducted emissions bottom channel 2110.0MHz 1GHz - 5GHz

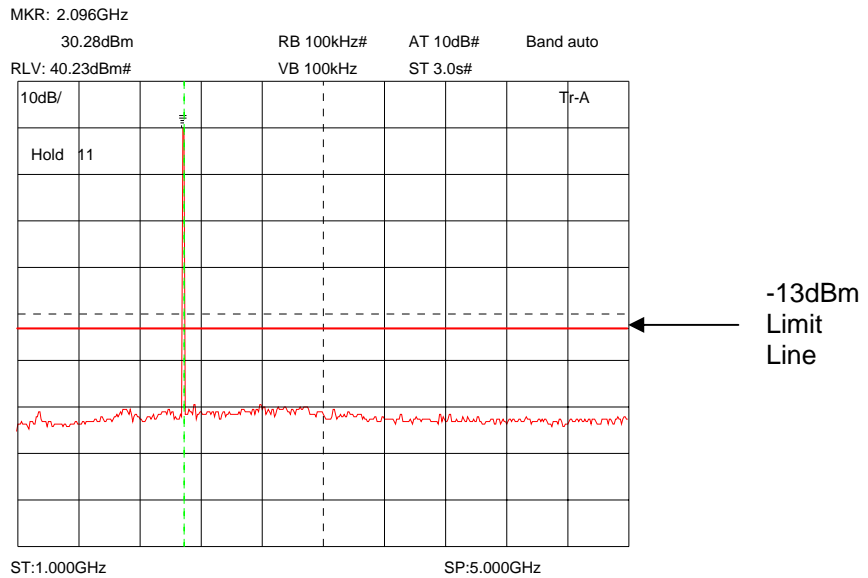

Conducted emissions bottom channel 2110.0MHz 5GHz - 10GHz

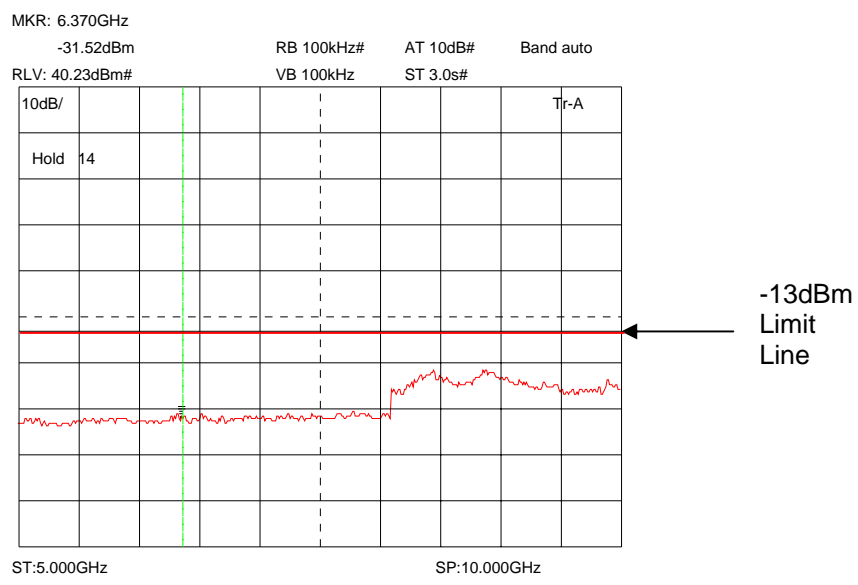

Conducted emissions bottom channel 2110.0MHz 10GHz - 15GHz

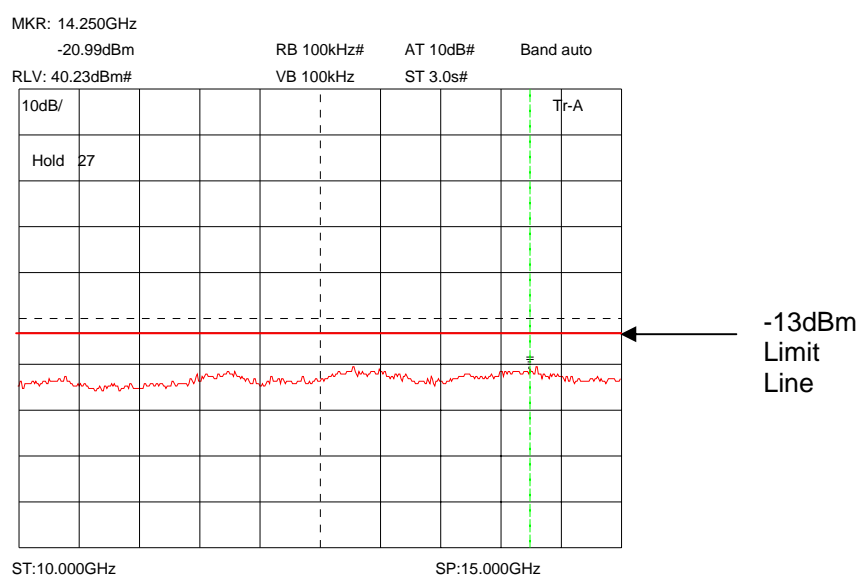

Conducted emissions bottom channel 2110.0MHz 15GHz - 21GHz

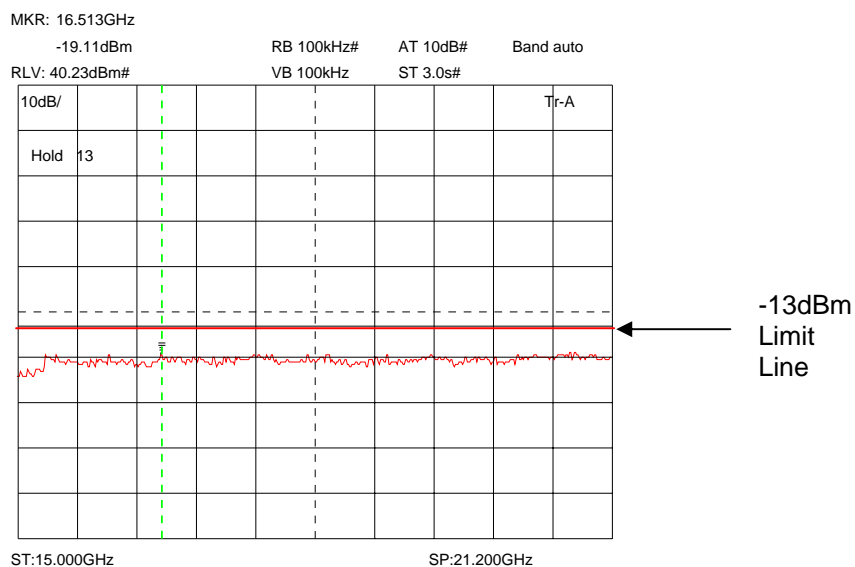

The above test results show that there were no emissions within 20dBs of the -13dBm limit.

Conducted emissions Mid channel 2132.5MHz 30MHz – 1GHz

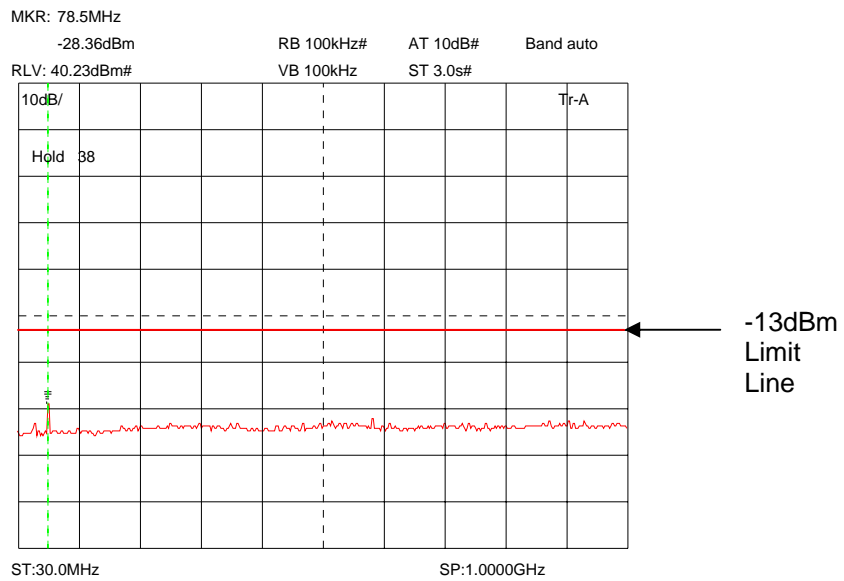

Conducted emissions Mid channel 2132.5MHz 1GHz - 5GHz

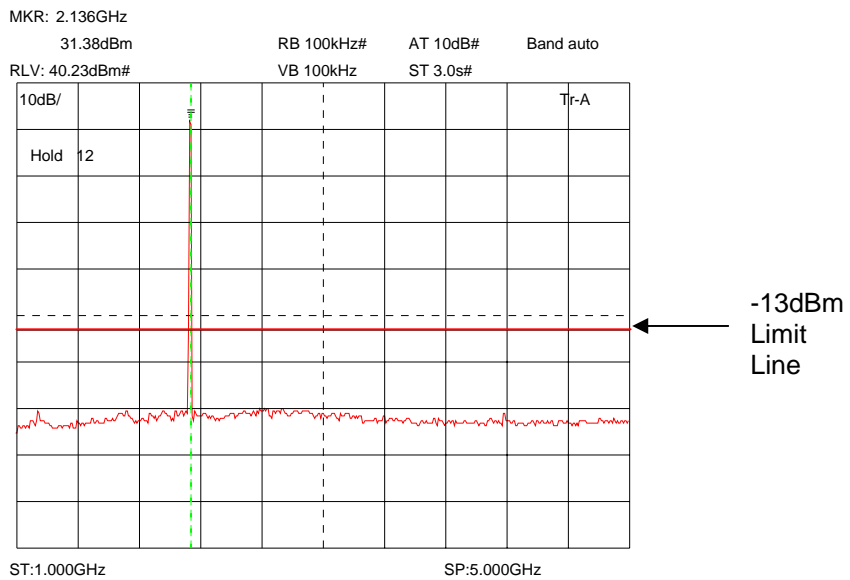

Conducted emissions Mid channel 2132.5MHz 5GHz - 10GHz

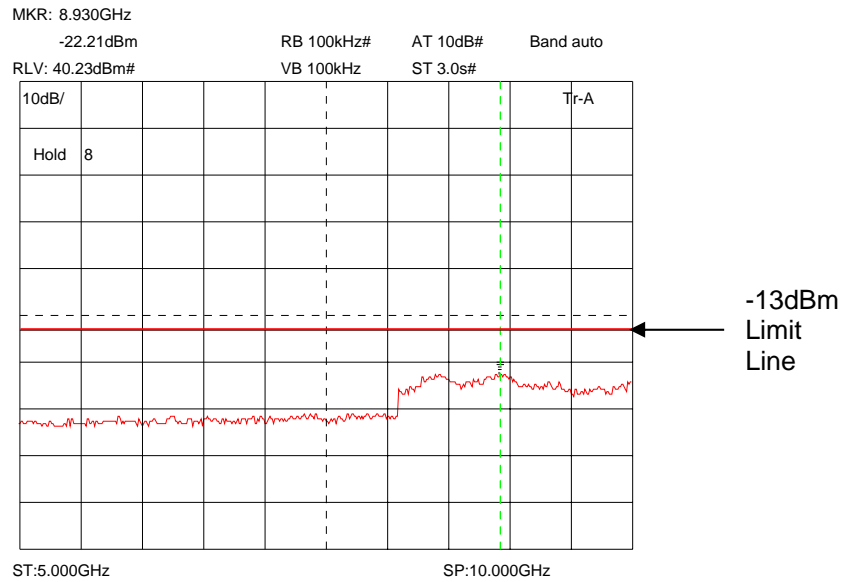

Conducted emissions Mid channel 2132.5MHz 10GHz - 15GHz

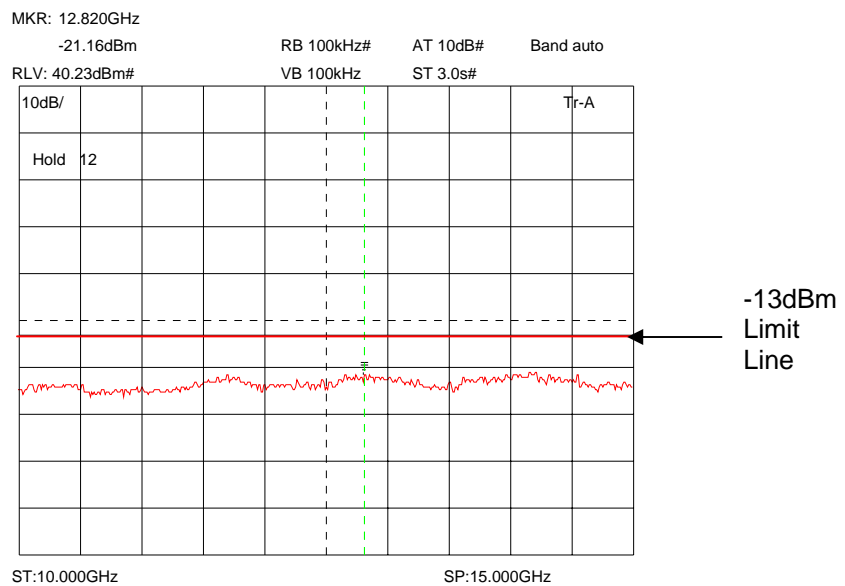

Conducted emissions Mid channel 2132.5MHz 15GHz - 21GHz

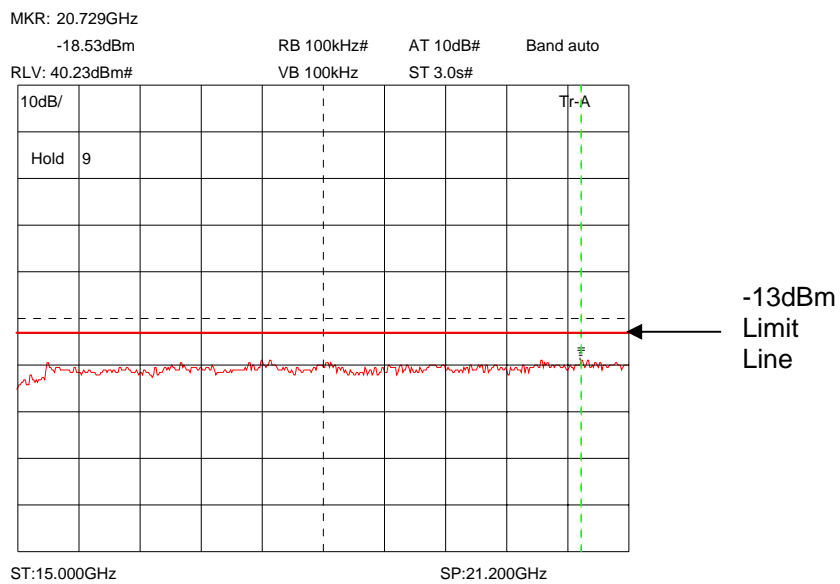

Conducted emissions Top channel 2155.0MHz 30MHz - 1GHz

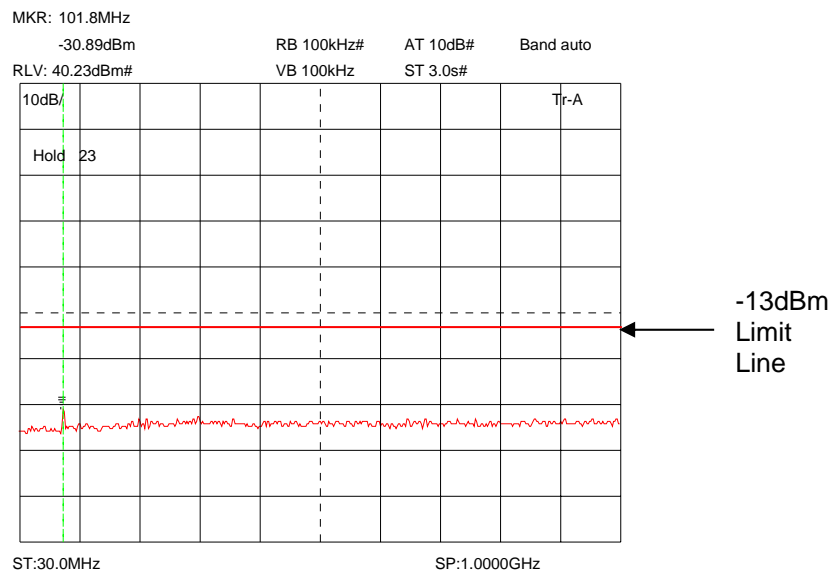

Conducted emissions Top channel 2155.0MHz 1GHz - 5GHz

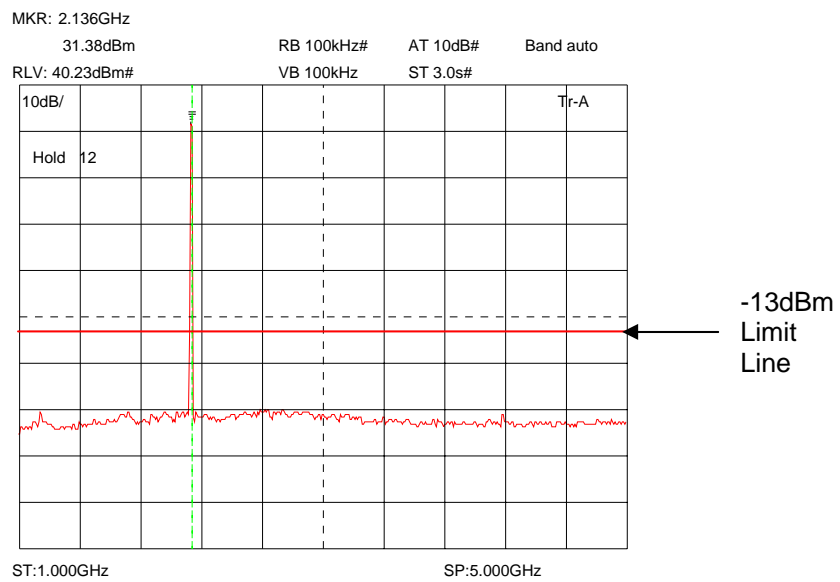

Conducted emissions Top channel 2155.0MHz 5GHz - 10GHz

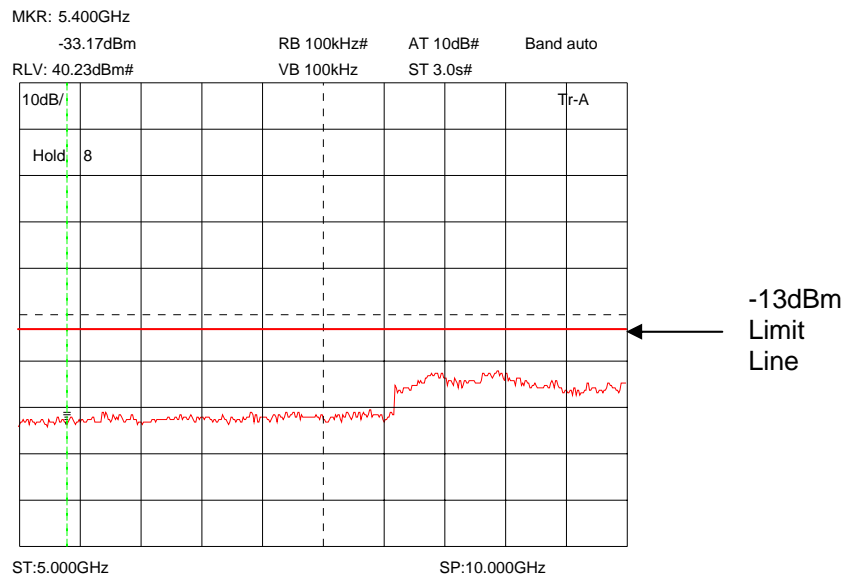

Conducted emissions Top channel 2155.0MHz 10GHz - 15GHz

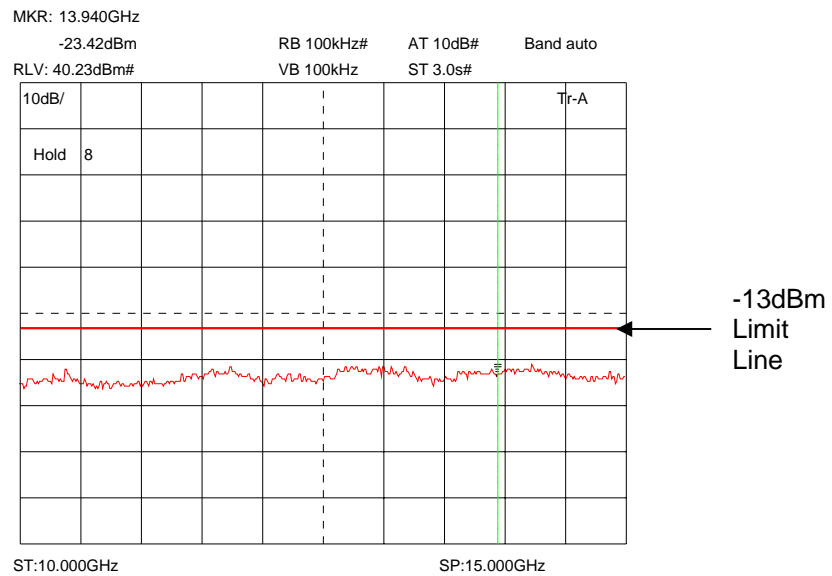

Conducted emissions Top channel 2155.0MHz 15GHz - 21GHz

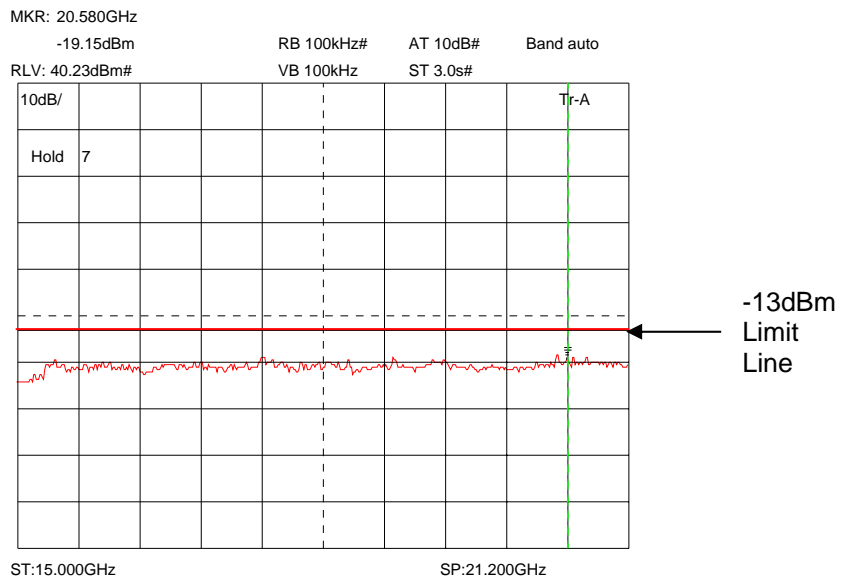

TRANSMITTER TESTS

AMPLIFIER SPURIOUS EMISSIONS – RADIATED – Part 27.53 – DOWNLINK

Ambient temperature = 15°C
 Relative humidity = 44%
 Conditions = OATS
 Supply voltage = +24Vdc
 Supply Frequency = N/A
 Test Signal = F3E

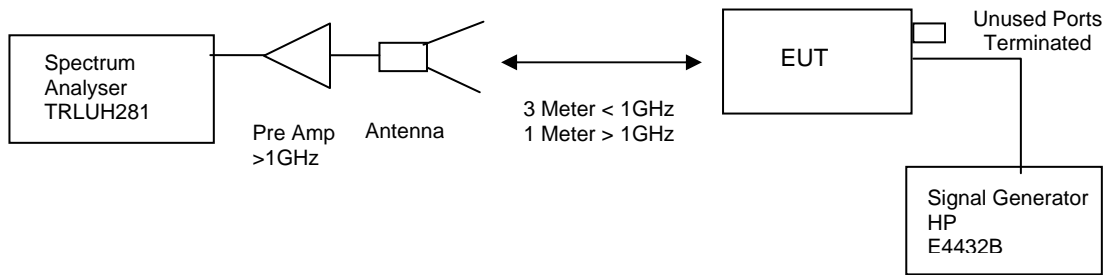

The test was set up as per the diagram. The level at the input was adjusted to compensate for the loss of the interconnecting cable. The unit was tested operating maximum power on three test frequencies with a 50 ohm load on the output. The unit was also tested with the signal generator replaced by another 50ohm load.

The Spurious limit was calculated as follows:

On any frequency removed from the assigned frequency by more that 250% of the authorised bandwidth

At least $43 + 10 \log P_{dB}$

$$(10\log P_{watts}) - (43+10\log (P_{watts} * 1000)) = \text{LIMIT} = -13 \text{ dBm}$$

RESULTS

FREQUENCY RANGE	FREQ. (MHz)	MEAS. Rx. (dBµV)	CABLE LOSS (dB)	ANT FACTOR	FIELD STRENGTH (dBµV/m)	CALCULATED EIRP (dBm)	LIMIT (dBm)
30MHz – 21GHz	No Significant Emissions Within 20dBs of the Limit						-13dBm

The test equipment used for the Transmitter Spurious Emissions:

TYPE OF EQUIPMENT	MAKER/SUPPLIER	MODEL No	SERIAL No	TRL No	ACTUAL EQUIPMENT USED
SPECTRUM ANALYSER	ANRITSU	MS2665C	MT26089	479	
HORN	EMCO	3115	9010-3580	138	X
SPECTRUM ANALYSER	R&S	FSU46	200034	UH281	X
PRE AMPLIFIER	HP	8449B	3008A016	572	X
ANTENNA	YORK	CBL611/A	1618	UH191	X
RECEIVER	R&S	ESVS10	825892/006	TRL04	X
SIGNAL GENERATOR	HP	E4432B	GB38100116		X

E-Field Radiation (30MHz-1GHz)

EUT: Fibre Feed Remote Amplifier
 Manuf: Axell Wireless
 Op Cond: Prescan 30MHz - 1000MHz
 Operator: S Hodgkinson
 Test Spec: Part15
 Comment: Tx bottom channel, downlink direction, permanent carrier, All ports terminated in 50 ohm loads. Unit lay horizontal terminals facing Rx antenna Vertical.

Scan Settings			(1 Range) Frequencies		Receiver Settings			
Start	Stop	Step	IF BW	Detector	M-Time	Atten	Preamp	OpRge
30MHz	1000MHz	50kHz	120kHz	PK	1msec	Auto	ON	60dB

Transducer	No.	Start	Stop	Name
1	21	30MHz	1000MHz	UH72
	22	30MHz	1000MHz	UH93

Final Measurement: Detector: X QP
 Meas Time: 2sec
 Subranges: 50
 Acc Margin: 10 dB

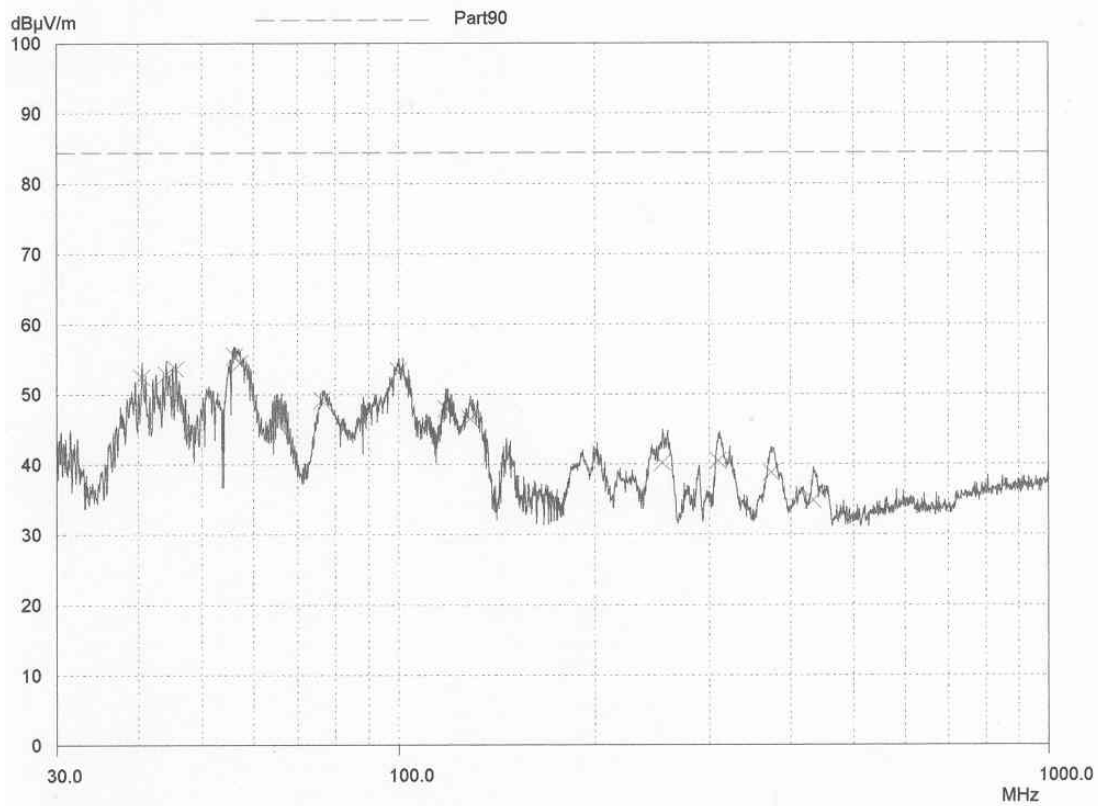

E-Field Radiation (30MHz-1GHz)

EUT: Fibre Feed Remote Amplifier
 Manuf: Axell Wireless
 Op Cond: Prescan 30MHz - 1000MHz
 Operator: S Hodgkinson
 Test Spec: Part15
 Comment: Tx middle channel, downlink direction, permanent carrier, All ports terminated in 50 ohm loads. Unit lay horizontal terminals facir
 Rx antenna ~~Horizontal~~ **VERTICAL**

Scan Settings		(1 Range) Frequencies			Receiver Settings			
Start	Stop	Step	IF BW	Detector	M-Time	Atten	Preamp	OpRge
30MHz	1000MHz	50kHz	120kHz	PK	1msec	Auto	ON	60dB

Transducer	No.	Start	Stop	Name
1	21	30MHz	1000MHz	UH72
	22	30MHz	1000MHz	UH93

Prescan Measurement:

Detector:	X PK
Meas Time:	see scan settings
Subranges:	8
Acc Margin:	20 dB

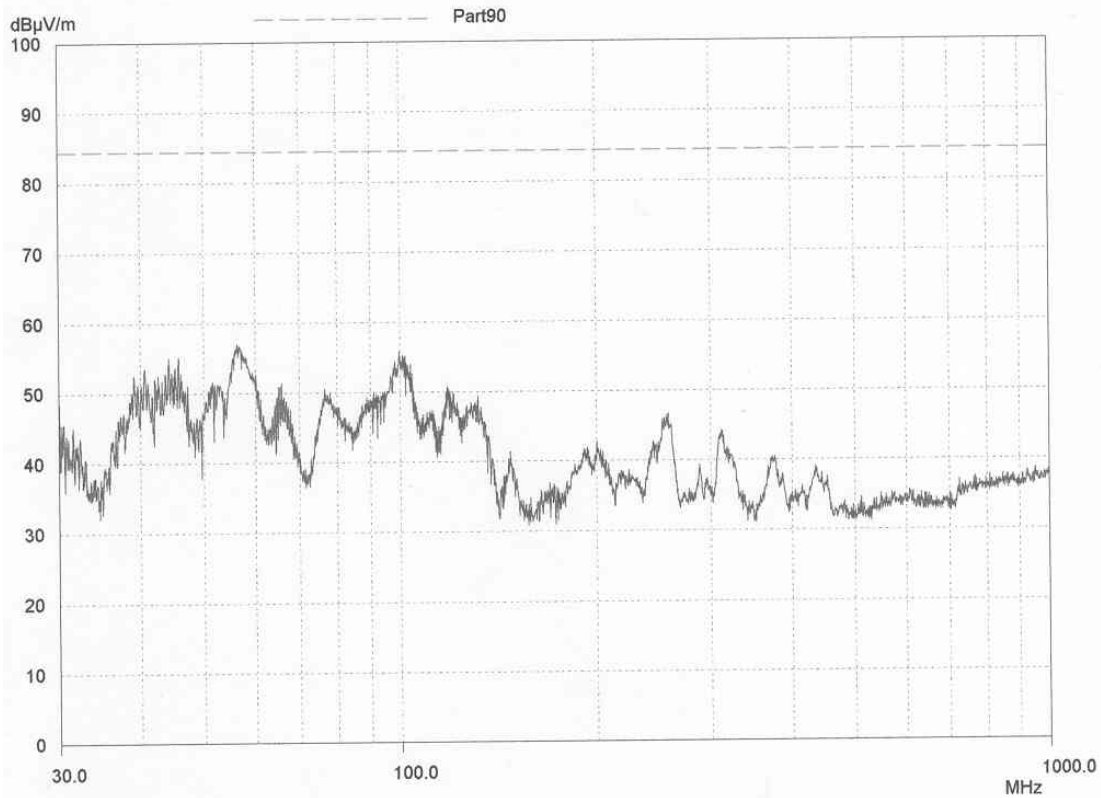

E-Field Radiation (30MHz-1GHz)

EUT: Fibre Feed Remote Amplifier
 Manuf: Axell Wireless
 Op Cond: Prescan 30MHz - 1000MHz
 Operator: S Hodgkinson
 Test Spec: Part15
 Comment: Tx top channel, downlink direction, permanent carrier, All ports terminated in 50 ohm loads. Unit lay horizontal terminals facing F
 Rx antenna Vertical.

Scan Settings			(1 Range) Frequencies		Receiver Settings				
Start	Stop	Step	IF BW	Detector	M-Time	Atten	Preamp	OpRge	
30MHz	1000MHz	50kHz	120kHz	PK	1msec	Auto	ON	60dB	

Transducer	No.	Start	Stop	Name
1	21	30MHz	1000MHz	UH72
	22	30MHz	1000MHz	UH93

Prescan Measurement: Detector: X PK
 Meas Time: see scan settings
 Subranges: 50
 Acc Margin: 10 dB

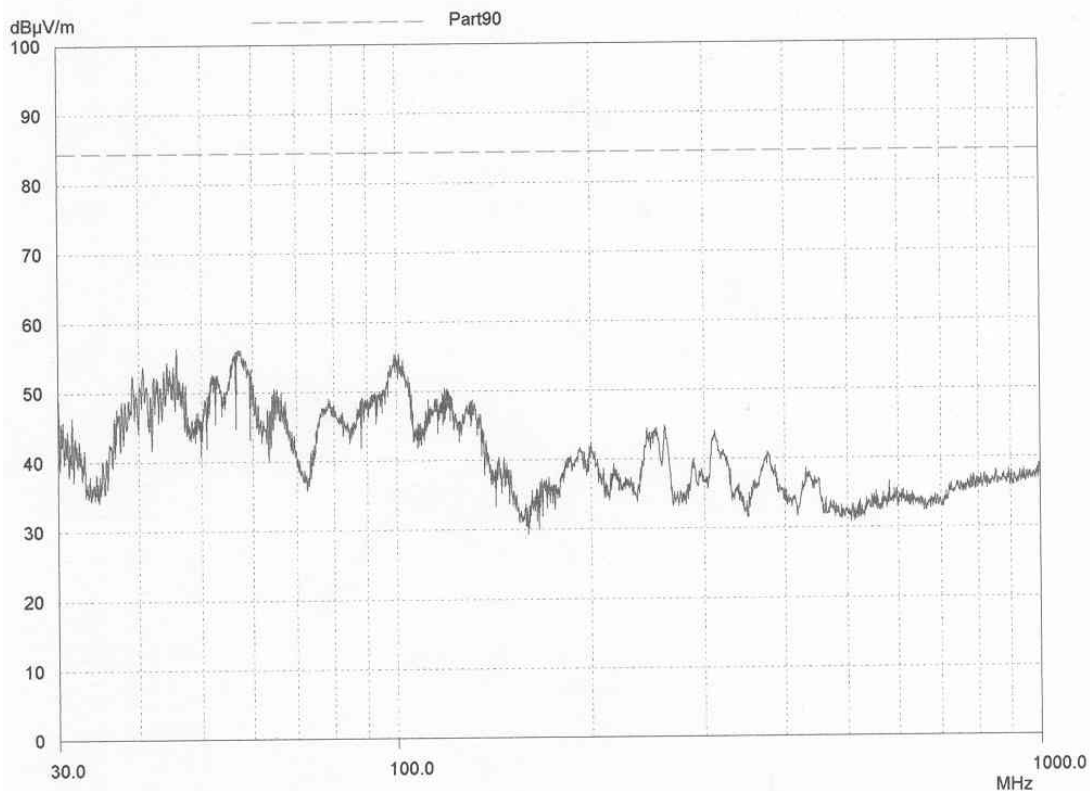

Radiated emissions bottom channel 2110.0MHz 1 – 5GHz

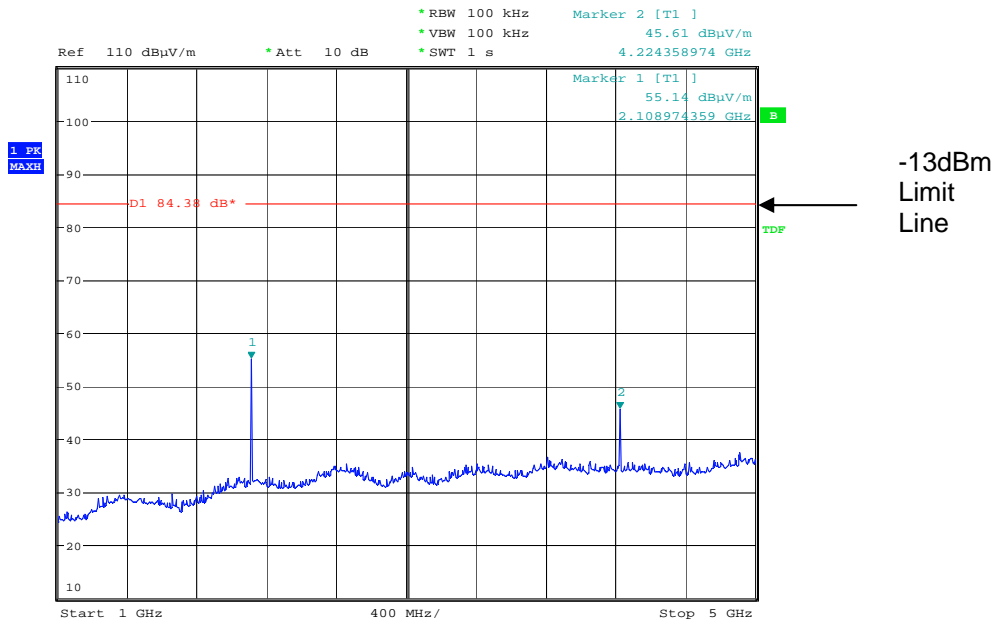

Date: 19.JUN.2008 10:07:16

Radiated emissions bottom channel 2110.0MHz 5 – 10GHz

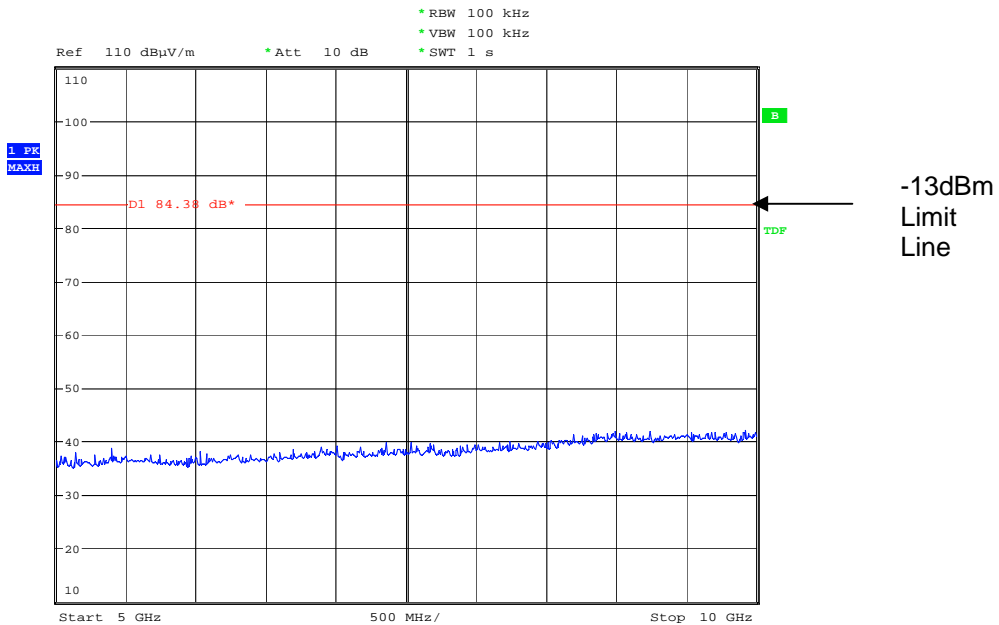

Date: 19.JUN.2008 10:08:17

Radiated emissions bottom channel 2110.0MHz 10 – 15GHz

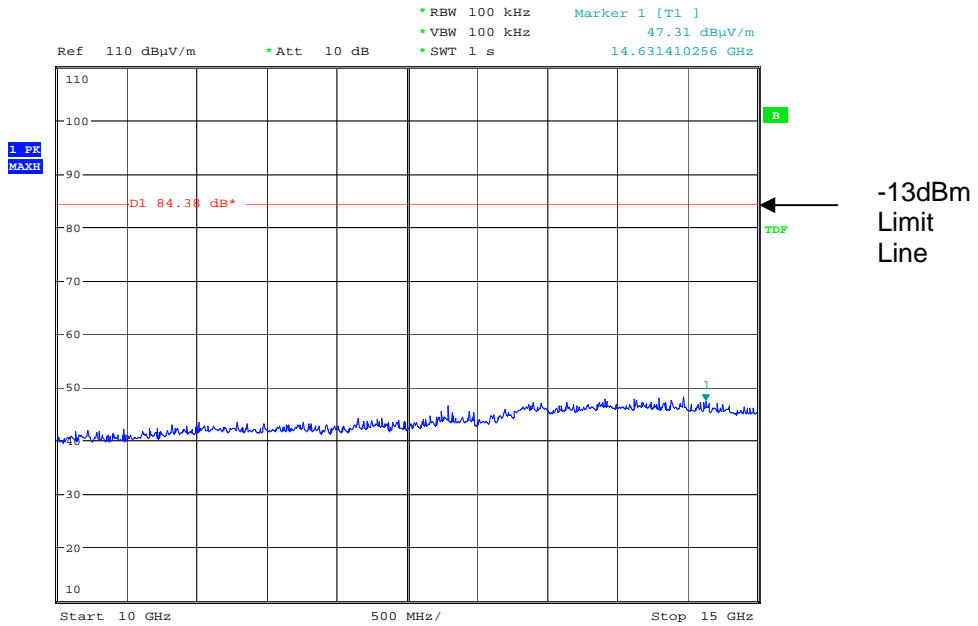

Date: 19.JUN.2008 10:09:19

Radiated emissions bottom channel 2110.0MHz 15 – 18GHz

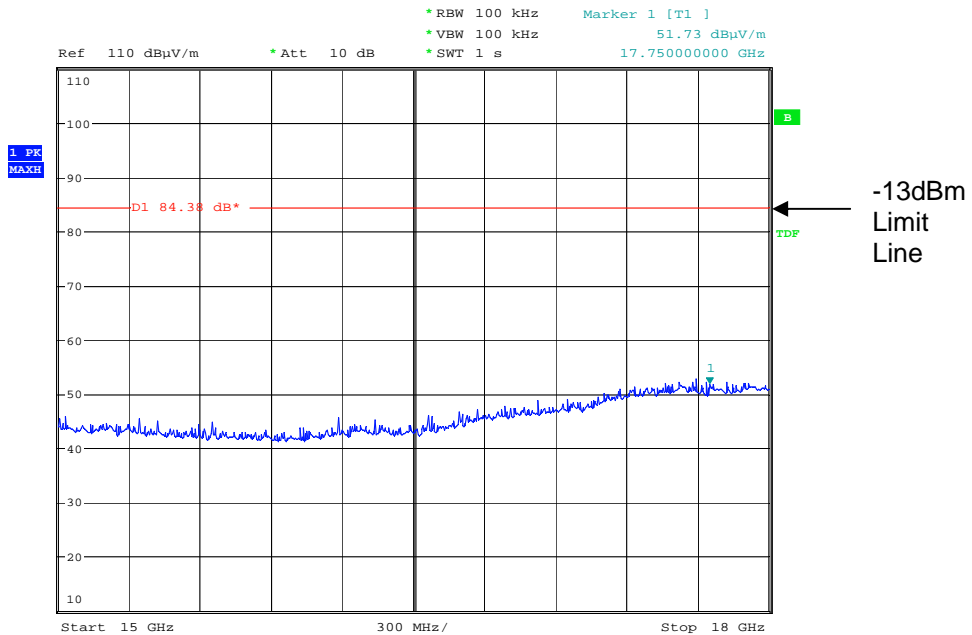

Date: 19.JUN.2008 10:12:38

Radiated emissions bottom channel 2110.0MHz 18 – 22GHz

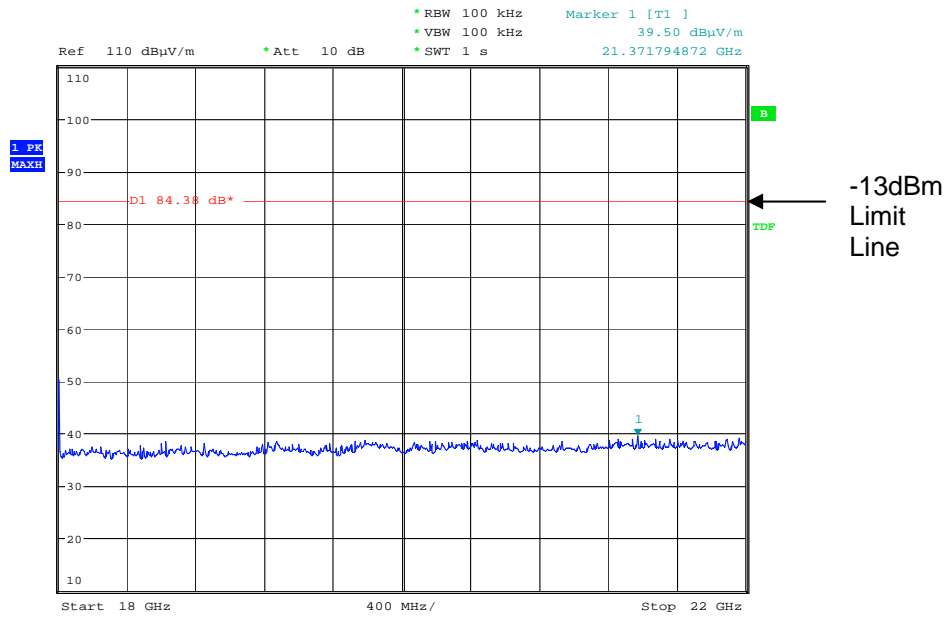

Date: 19.JUN.2008 10:13:43

Radiated emissions Middle channel 2132.5MHz 1 – 5GHz

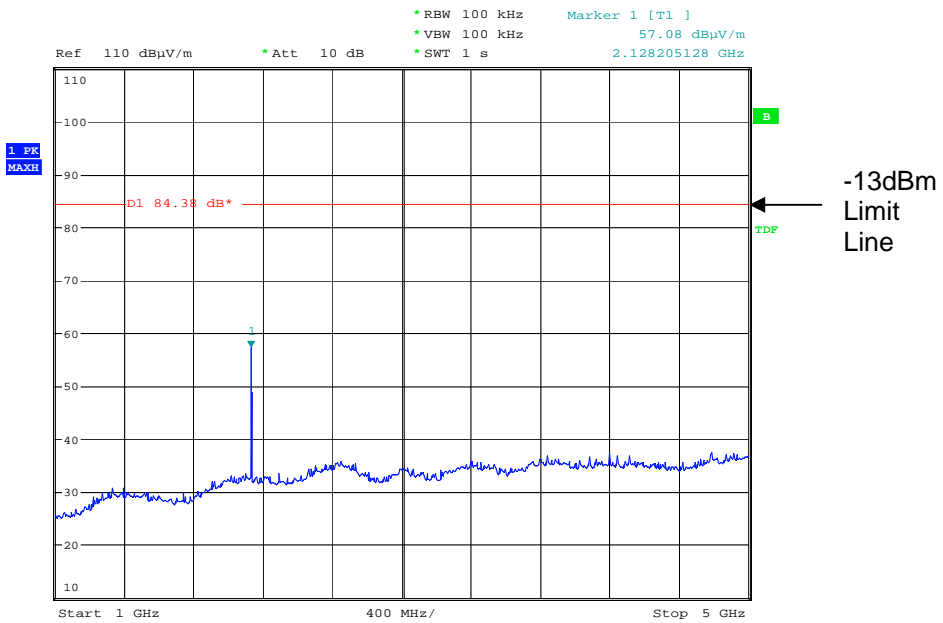

Date: 19.JUN.2008 10:23:00

Radiated emissions Middle channel 2132.5MHz 5 – 10GHz

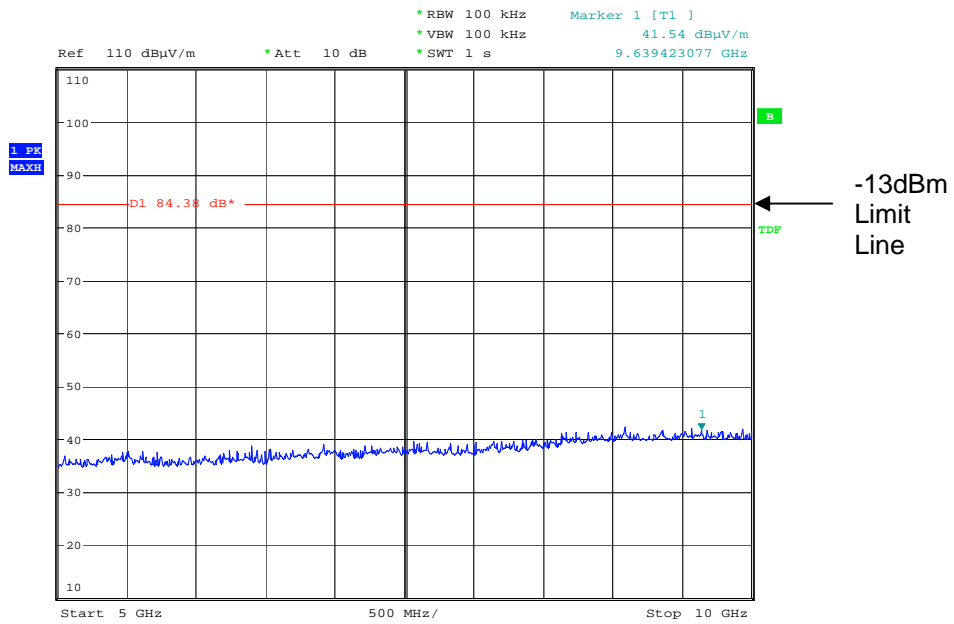

Date: 19.JUN.2008 10:24:05

Radiated emissions Middle channel 2132.5MHz 10 – 15GHz

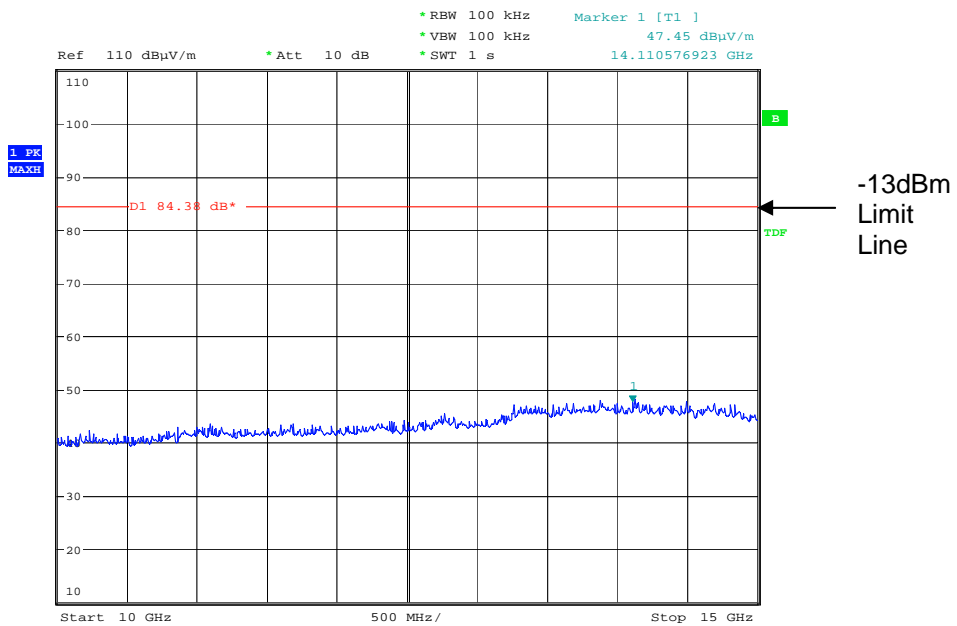

Date: 19.JUN.2008 10:24:41

Radiated emissions Middle channel 2132.5MHz 15 – 18GHz

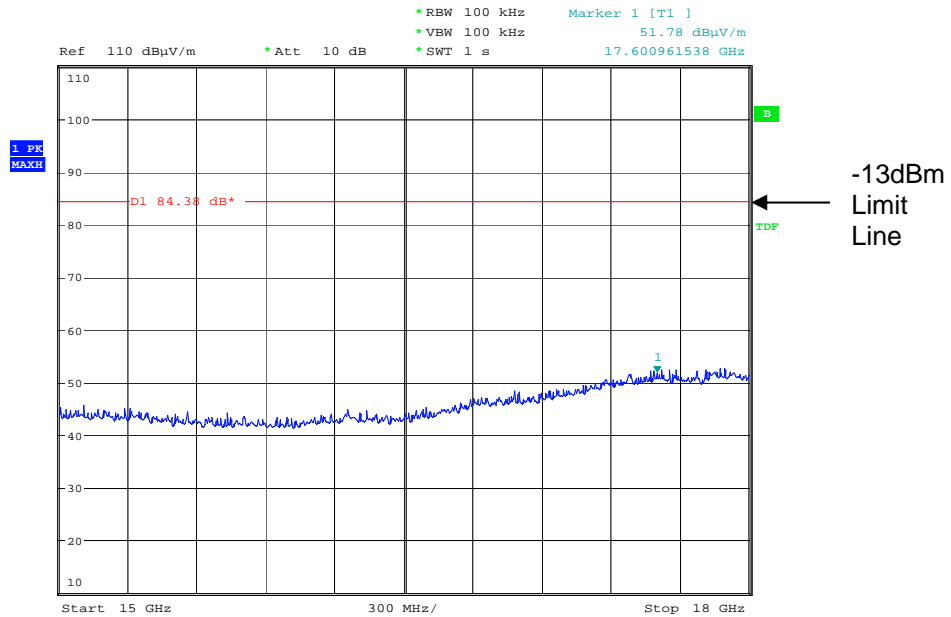

Date: 19.JUN.2008 10:25:20

Radiated emissions Middle channel 2132.5MHz 18 – 22GHz

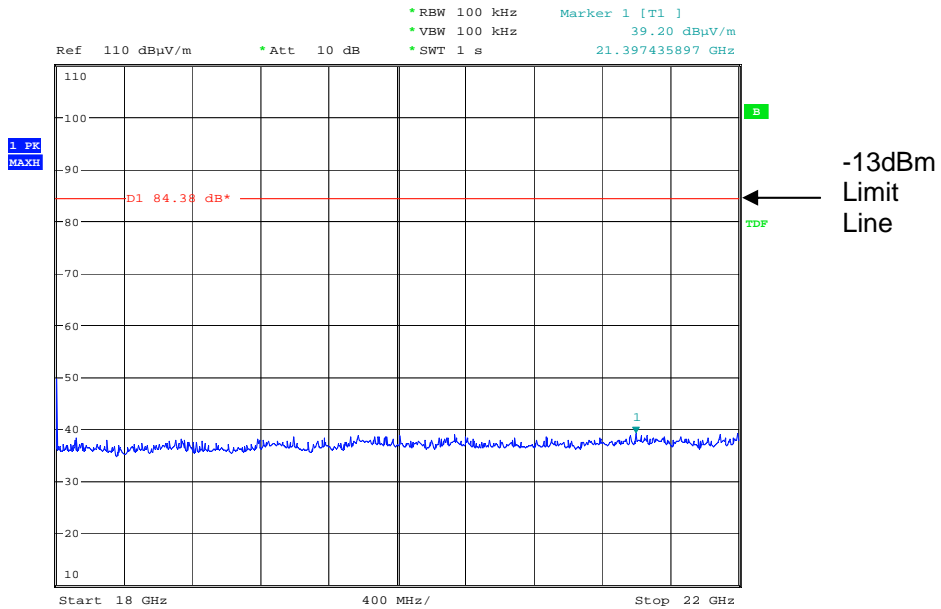

Date: 19.JUN.2008 10:26:23

The above test results show that there were no emissions within 20dBs of the -13dBm limit.

Radiated emissions Top channel 2155.0 MHz 1 – 5GHz

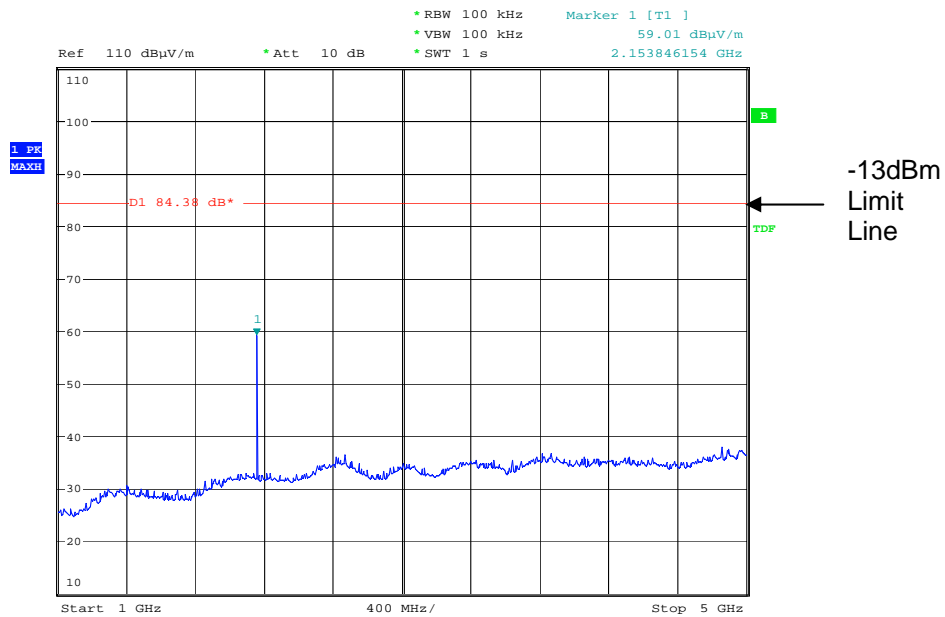

Date: 19.JUN.2008 10:35:45

Radiated emissions Top channel 2155.0 MHz 5 – 10GHz

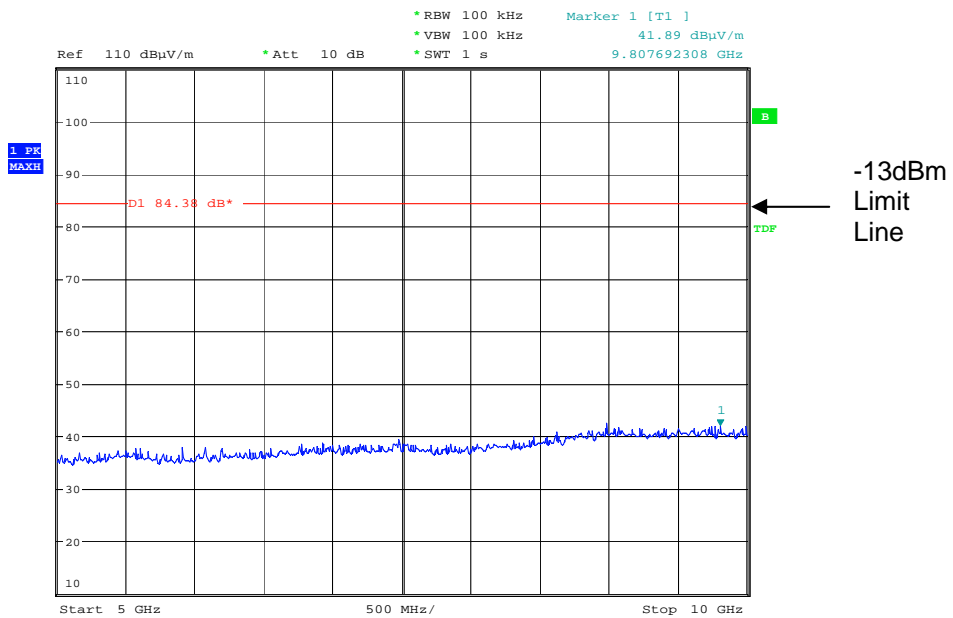

Date: 19.JUN.2008 10:36:51

Radiated emissions Top channel 2155.0 MHz 10 – 15GHz

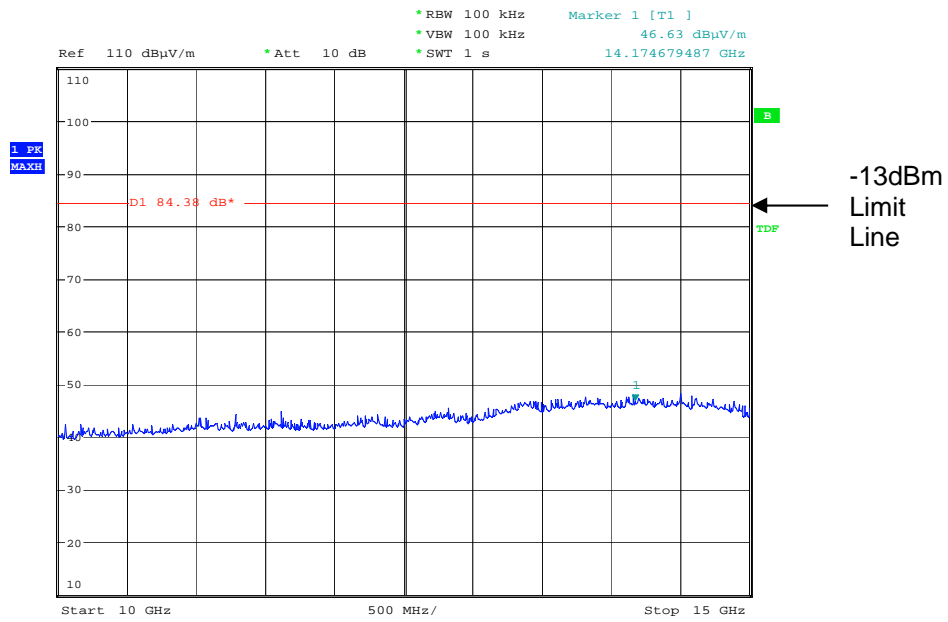

Date: 19.JUN.2008 10:37:37

Radiated emissions Top channel 2155.0 MHz 15 – 18GHz

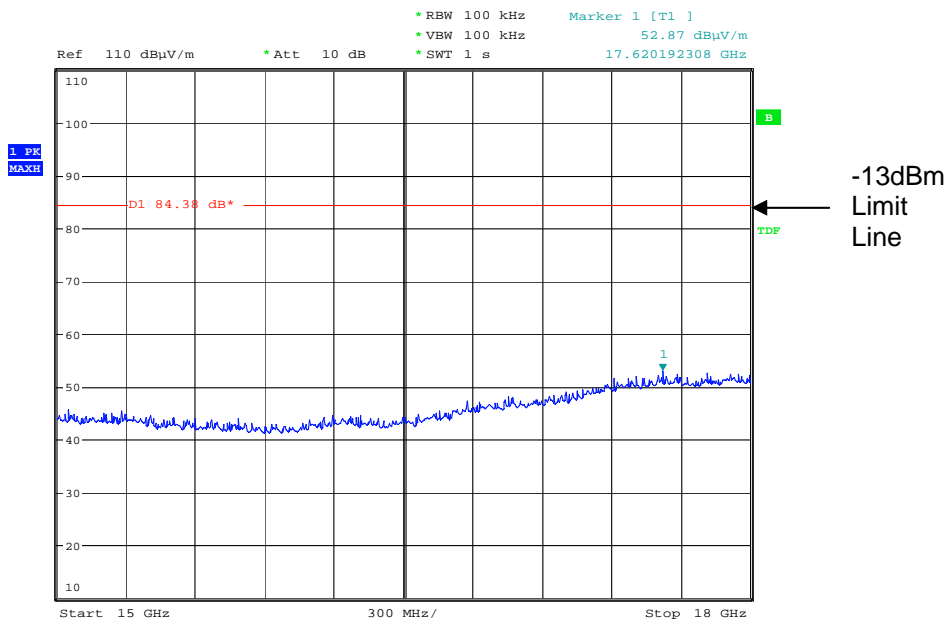

Date: 19.JUN.2008 10:38:15

Radiated emissions Top channel 2155.0 MHz 18 – 22GHz

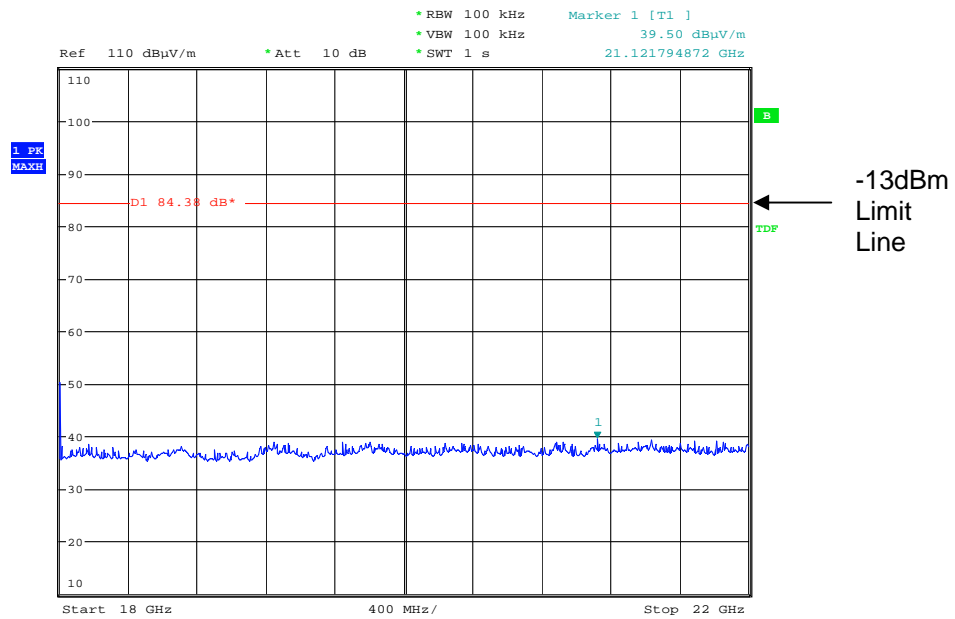

Date: 19.JUN.2008 10:39:04

The above test results show that there were no emissions within 20dBs of the -13dBm limit.

ANNEX A
PHOTOGRAPHS





ANNEX B
APPLICANT'S SUBMISSION OF DOCUMENTATION LIST

APPLICANT'S SUBMISSION OF DOCUMENTATION LIST

a.	TCB	-	APPLICATION	[X]
		-	FEE	[X]
b.	AGENT'S LETTER OF AUTHORISATION	-		[X]
c.	MODEL(s) vs IDENTITY	-		[X]
d.	ALTERNATIVE TRADE NAME DECLARATION(s)	-		[]
e.	LABELLING	-	PHOTOGRAPHS	[X]
		-	DECLARATION	[X]
		-	DRAWINGS	[X]
f.	TECHNICAL DESCRIPTION	-		[X]
g.	BLOCK DIAGRAMS	-	Tx	[X]
		-	Rx	[]
		-	PSU	[]
		-	AUX	[]
h.	CIRCUIT DIAGRAMS	-	Tx	[X]
		-	Rx	[]
		-	PSU	[]
		-	AUX	[]
i.	COMPONENT LOCATION	-	Tx	[X]
		-	Rx	[]
		-	PSU	[]
		-	AUX	[]
j.	PCB TRACK LAYOUT	-	Tx	[X]
		-	Rx	[]
		-	PSU	[]
		-	AUX	[]
k.	BILL OF MATERIALS	-	Tx	[X]
		-	Rx	[]
		-	PSU	[]
		-	AUX	[]
l.	USER INSTALLATION / OPERATING INSTRUCTIONS	-		[X]

ANNEX C
EQUIPMENT CALIBRATION

TRL Number	Equipment Type	Manufacturer	Last Cal Calibration	Calibration Period	Due For Calibration
UH06/07	IC OATS Submission	TRL	01/06/2007	24	01/06/2009
UH006	3m Range ERP CAL	TRL	08/12/2006	12	08/12/2007
UH028	Log Periodic Ant	Schwarbeck	30/05/2007	24	30/05/2009
UH029	Bicone Antenna	Schwarbeck	22/05/2007	24	22/05/2009
UH041	Multimeter	AVOmeter	04/01/2007	12	04/01/2008
UH089	Signal Generator	Marconi	09/01/2007	12	09/01/2008
UH093	Bilog Antenna	Chase	21/05/2007	24	21/05/2009
UH105	Signal Generator	Marconi	31/05/2007	12	31/05/2008
UH132	Power meter	Marconi	10/01/2007	12	10/01/2008
UH162	ERP Cable Cal	TRL	02/01/2007	12	02/01/2008
UH228	Power Sensor	Marconi	15/01/2007	12	15/01/2008
UH253	1m Cable N type	TRL	07/12/2006	12	07/12/2007
UH254	1m Cable N type	TRL	07/12/2006	12	07/12/2007
UH265	Notch filer	Telonic	11/01/2006	24	11/01/2008
UH269	1m Cable N type	TRL	07/12/2006	12	07/12/2007
UH270	1m Cable N type	TRL	07/12/2006	12	07/12/2007
UH271	1.5m Cable N type	TRL	07/12/2006	12	07/12/2007
UH272	1.5m Cable N type	TRL	07/12/2006	12	07/12/2007
UH273	2m Cable N type	TRL	07/12/2006	12	07/12/2007
UH274	2m Cable N type	TRL	07/12/2006	12	07/12/2007
UH281	Spectrum Analyser	R&S	24/07/2006	12	24/07/2007
UH297	Signal Generator	R&S	30/05/2007	12	30/05/2008
UH340	Signal Generator	HP	29/06/2006	12	29/06/2007
L005	CMTA	R&S	10/01/2007	12	10/01/2008
L007	Loop Antenna	R&S	22/05/2007	24	22/05/2009
L103	Attenuator	Bird		Calibrate in Use	
L112	Attenuator	Bird		Calibrate in Use	
L138	1-18GHz Horn	EMCO	23/05/2007	24	23/05/2009
L139	1-18GHz Horn	EMCO	23/05/2007	24	23/05/2009
L170	Combiner	Elcom		Calibrate in Use	
L176	Signal Generator	Marconi	01/03/2007	12	01/03/2008
L220	Attenuator	Bird		Calibrate in Use	
L426	Temperature Indicator	Fluke	09/01/2007	12	09/01/2008
L479	Analyser	Anritsu	09/01/2007	12	09/01/2008
L572	Pre Amplifier	HP		Calibrate in Use	

ANNEX D
MEASUREMENT UNCERTAINTY

Radio Testing – General Uncertainty Schedule

All statements of uncertainty are expanded standard uncertainty using a coverage factor of 1.96 to give a 95% confidence where no required test level exists.

[1] Adjacent Channel Power

Uncertainty in test result = **1.86dB**

[2] Carrier Power

Uncertainty in test result (Equipment - TRLUH120) = **2.18dB**

Uncertainty in test result (Equipment – TRL05) = **1.08dB**

Uncertainty in test result (Equipment – TRL479) = **2.48dB**

[3] Effective Radiated Power

Uncertainty in test result = **4.71dB**

[4] Spurious Emissions

Uncertainty in test result = **4.75dB**

[5] Maximum frequency error

Uncertainty in test result (Equipment - TRLUH120) = **119ppm**

Uncertainty in test result (Equipment – TRL05) = **0.113ppm**

Uncertainty in test result (Equipment – TRL479) = **0.265ppm**

[6] Radiated Emissions, field strength OATS 14kHz-18GHz Electric Field

Uncertainty in test result (14kHz – 30MHz) = **4.8dB**, Uncertainty in test result (30MHz – 1GHz) = **4.6dB**,

Uncertainty in test result (1GHz-18GHz) = **4.7dB**

[7] Frequency deviation

Uncertainty in test result = **3.2%**

[8] Magnetic Field Emissions

Uncertainty in test result = **2.3dB**

[9] Conducted Spurious

Uncertainty in test result (Equipment TRL479) Up to 8.1GHz = **3.31dB**

Uncertainty in test result (Equipment TRL479) 8.1GHz – 15.3GHz = **4.43dB**

Uncertainty in test result (Equipment TRL479) 15.3GHz – 21GHz = **5.34dB**

Uncertainty in test result (Equipment TRLUH120) Up to 26GHz = **3.14dB**

[10] Channel Bandwidth

Uncertainty in test result = **15.5%**

[11] Amplitude and Time Measurement – Oscilloscope

Uncertainty in overall test level = **2.1dB**, Uncertainty in time measurement = **0.59%**, Uncertainty in Amplitude measurement = **0.82%**

[11] Power Line Conduction

Uncertainty in test result = **3.4dB**

[12] Spectrum Mask Measurements

Uncertainty in test result = **2.59% (frequency)**
Uncertainty in test result = **1.32dB (amplitude)**

[13] Adjacent Sub Band Selectivity

Uncertainty in test result = **1.24dB**

[14] Receiver Blocking – Listen Mode, Radiated

Uncertainty in test result = **3.42dB**

[15] Receiver Blocking – Talk Mode, Radiated

Uncertainty in test result = **3.36dB**

[16] Receiver Blocking – Talk Mode, Conducted

Uncertainty in test result = **1.24dB**

[17] Receiver Threshold

Uncertainty in test result = **3.23dB**

[18] Transmission Time Measurement

Uncertainty in test result = **7.98%**