

TEST REPORT NO: RU1220/6818
COPY NO: 2
ISSUE NO: 1
FCC ID: NEO60-1376SERIES

**REPORT ON THE CERTIFICATION TESTING OF A
AERIAL FACILITIES LIMITED
60-137705 & 80-245102
WITH RESPECT TO
THE FCC RULES CFR 47, PART 90 Subpart I
PRIVATE LAND MOBILE REPEATER.**

TEST DATE: 11th – 17th January 2006

TESTED BY: _____ D WINSTANLEY
APPROVED BY: _____ P GREEN
PRODUCT MANAGER
EMC
DATE: 20th March 2006 _____

Distribution:

- Copy Nos:
1. Aerial Facilities Limited
 2. TCB: TRL Compliance Limited
 3. TRL Compliance Ltd

THIS DOCUMENT MAY BE REPRODUCED ONLY IN ITS ENTIRETY AND WITHOUT CHANGE

TRL COMPLIANCE LTD

LONG GREEN FORTHAMPTON GLOUCESTER GL19 4QH UNITED KINGDOM
TELEPHONE +44 (0)1684 833818 FAX +44 (0)1684 833858
E-MAIL test@trlcompliance.com www.trlcompliance.com

CONTENTS

	PAGE		
CERTIFICATE OF CONFORMITY & COMPLIANCE	3		
APPLICANT'S SUMMARY	4		
EQUIPMENT TEST CONDITIONS	5		
TESTS REQUIRED	5		
TEST RESULTS	6-39		
		ANNEX	
PHOTOGRAPHS		A	
PHOTOGRAPH No. 1: Test setup			
PHOTOGRAPH No. 2: Test setup			
APPLICANT'S SUBMISSION OF DOCUMENTATION LIST		B	
EQUIPMENT CALIBRATION		C	
MEASUREMENT UNCERTAINTY		D	
SYSTEM DIAGRAM		E	
Notes:			
1. Component failure during test		YES	<input type="checkbox"/>
		NO	<input checked="" type="checkbox"/>
2. If Yes, details of failure:			
3. The facilities used for the testing of the product contain in this report are FCC Listed.			

CERTIFICATE OF CONFORMITY & COMPLIANCE

FCC IDENTITY:	NEO60-1376SERIES
PURPOSE OF TEST:	Certification
TEST SPECIFICATION:	FCC RULES CFR 47, Part 90 Subpart I
TEST RESULT:	Compliant to Specification
EQUIPMENT UNDER TEST:	60-137705 & 80-245102
EQUIPMENT TYPE:	Private Land Mobile Repeater
MAXIMUM GAIN	Uplink 61.91dB Downlink 60.92dB
MAXIMUM INPUT	Uplink -62.3 dBm Downlink -21.3 dBm
MAXIMUM OUTPUT	Uplink -0.39 dBm (input from fibre optic system) Downlink 39.62 dBm (radiating cable system)
ANTENNA TYPE:	Not applicable
CHANNEL SPACING:	Uplink, Determined by input signal channelisation Downlink, Determined by input signal channelisation
NUMBER OF CHANNELS:	Uplink, Determined by input signal channelisation Downlink, Determined by input signal channelisation
FREQUENCY GENERATION:	N/A
MODULATION TYPE:	F3E
POWER SOURCE(s):	+110 Vac
TEST DATE(s):	11 th – 17 th January 2006
ORDER No(s):	34696
APPLICANT:	Aerial Facilities Limited
ADDRESS:	Aerial House Asheridge Road Chesham Buckinghamshire HP5 1TU United Kingdom
TESTED BY:	----- D WINSTANLEY
APPROVED BY:	----- P GREEN PRODUCT MANAGER EMC

APPLICANT'S SUMMARY

EQUIPMENT UNDER TEST (EUT): 60-137705 & 80-245102

EQUIPMENT TYPE: Private Land Mobile Repeater

PURPOSE OF TEST: Certification

TEST SPECIFICATION(S): FCC RULES CFR 47, Part 90 Subpart I

TEST RESULT: COMPLIANT Yes
 No

APPLICANT'S CATEGORY: MANUFACTURER
 IMPORTER
 DISTRIBUTOR
 TEST HOUSE
 AGENT

APPLICANT'S ORDER No(s): 34696

APPLICANT'S CONTACT PERSON(s): Mr Peter Bradfield

 E-mail address: Peterb@aerial.co.uk

APPLICANT: Aerial Facilities Limited

ADDRESS: Aerial House
 Asheridge Road
 Chesham
 Buckinghamshire
 HP5 1TU
 United Kingdom

 TEL: +44 (0)1494 777000

 FAX: +44 (0)1494 778456

MANUFACTURER: Aerial Facilities Limited

EUT(s) COUNTRY OF ORIGIN: United Kingdom

TEST LABORATORY: TRL Compliance Ltd.

UKAS ACCREDITATION No: 0728

TEST DATE(S) 11th – 19th January 2006

TEST REPORT No: RU1220/6818

EQUIPMENT TEST / EXAMINATIONS REQUIRED

1.	TEST/EXAMINATION	RULE PART	APPLICABILITY	RESULT
	RF Power Output	90.205	Yes	Complies
	Audio Frequency Response	TIA EIA-603.3.2.6	N/A	N/A
	Audio Low-Pass Filter Response	TIA EIA-603.3.2.6	N/A	N/A
	Modulation Limiting	TIA EIA-603.3.2.6	N/A	N/A
	Occupied Bandwidth	90.210	Yes	Complies
	Spurious Emissions at Antenna Terminals	90.210	Yes	Complies
	Field Strength of Spurious Emissions	90.210	Yes	Complies
	Frequency Stability	90.213	N/A(note 1)	N/A
	Transient behaviour	90.214	N/A(note 2)	N/A

Notes:

1 The EUT does not contain modulation circuitry, therefore the test was not performed.

2 The EUT is not a keyed carrier system, therefore the test was not performed.

- | | | | | |
|----|----------------------|------------------------------|-------------|-------------|
| 2. | Product class: | Uplink | Class A [] | Class B [X] |
| | | Downlink | Class A [] | Class B [X] |
| 3. | Product Use: | Private Land Mobile Repeater | | |
| 4. | Emission Designator: | F3E | | |
| 5. | Temperatures: | Ambient (Tnom) | 21°C | |
| 6. | Supply Voltages: | Vnom | +110 Vac | |

Note: Vnom voltages are as stated above unless otherwise shown on the test report page

- | | | | |
|----|---------------------|------------------------|-----|
| 7. | Equipment Category: | Single channel | [] |
| | | Two channel | [] |
| | | Multi-channel | [X] |
| 8. | Channel spacing: | Narrowband | [] |
| | | Wideband | [X] |
| 9. | Test Location | TRL Compliance Limited | |
| | | Up Holland | [X] |
| | | Long Green | [] |

- | | | |
|-----|--|----------------------------------|
| 10. | Modifications made during test program | No modifications were performed. |
|-----|--|----------------------------------|

System description:

The 60-137705 and 80-245102 make up a bidirectional amplifier consisting of an uplink and a downlink. The uplink operates in the frequency band 417 MHz – 420MHz. The uplink input is determined by input signal channelisation and the output of the amplifier is fed into a fibre optic system FCC IDs NE020-0040Series and NE020-0041Series. The downlink operates in the frequency band 408.0 – 411.0 MHz. The downlink output of the amplifier is fed into a radiating cable system. The 60-137705 and 80-245102 are incorporated into a system as shown in Annex E.

COMPLIANCE TESTS

AMPLIFIER GAIN – CONDUCTED – PART 2.1046 – UPLINK

Ambient temperature = 22°C
 Relative humidity = 53%
 Supply voltage = +110 Vac
 Channel number = See test results

Radio Laboratory

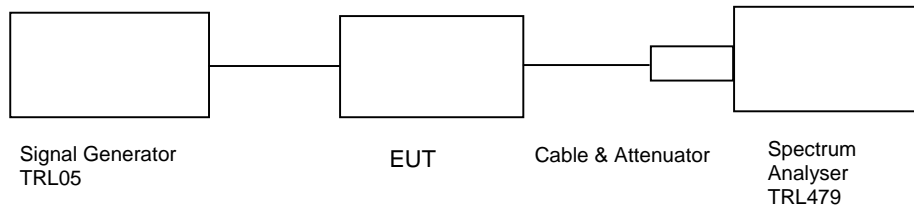

Frequency MHz	Signal Generator input level dBm	Cable & Attenuator loss dB	Level at Spectrum Analyser dBm	Gain dB	Output Power dBm	Gain after 10dB input level increase dBm
417.0	-61.30	10.15	-10.77	60.68	-0.62	50.91
418.5	-62.30	10.15	-10.54	61.91	-0.39	51.92
420.0	-61.30	10.15	-10.54	60.91	-0.39	50.92

Notes:

1. The level of the signal generator takes into consideration the loss from the cable.
2. The signal generator input was increased by 10dBs and the level of the output signal remeasured

TYPE OF EQUIPMENT	MAKER/SUPPLIER	MODEL No	SERIAL No	TRL No	ACTUAL EQUIPMENT USED
SPECTRUM ANALYSER	ANRITSU	MS2665C	MT26089	479	X
ATTENUATOR	BIRD	8308-100	N/A	112	X
CABLE	ROSENBERGER	MICRO COAX	N/A	280	X
SIGNAL GENERATOR	RHODE & SCHWARZ	CMTA 52	894715/003	05	X

AMPLIFIER INTERMODULATION SPURIOUS EMISSIONS – CONDUCTED – PART 2.1053– UPLINK

Ambient temperature = 18°C
 Relative humidity = 56%
 Supply voltage = +110 Vac

Radio Laboratory

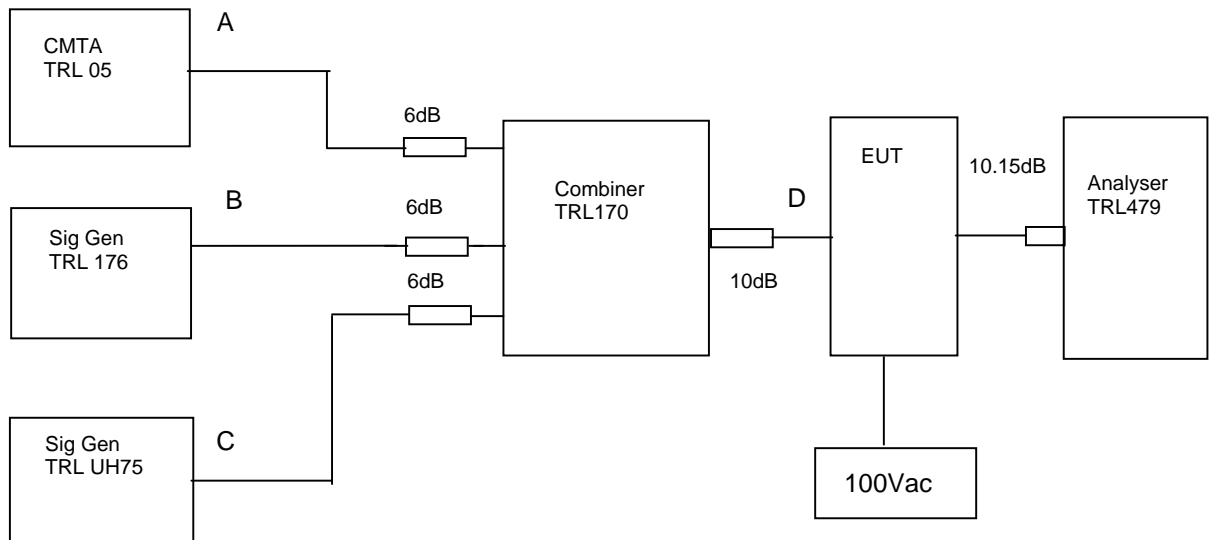

The intermodulation and spurious products were measured with the amplifier operating at maximum gain. A three tone test was conducted using the equipment as above. The input power level was adjusted so the level at point D was 10dB above the maximum input of -61.3dBm. The cable and attenuator loss between the EUT and the spectrum analyser was 10.15dB.

RF Input Frequency (MHz)			Highest Intermodulation Product Level (dBm)	Limit (dBm)
417.0	419.0	420.0	-70.73 dBm @ 418.0 MHz	-13

Sweep data is shown on the next page:

Test equipment used for intermodulation test

TYPE OF EQUIPMENT	MAKER/SUPPLIER	MODEL No	SERIAL No	TRL No	ACTUAL EQUIPMENT USED
SPECTRUM ANALYSER	ANRITSU	MS2665C	MT26089	479	X
SIGNAL GENERATOR	MARCONI	2022D	119215/058	UH75	X
CMTA	ROHDE & SCHWARZ	CMTA52	894715/033	05	X
SIGNAL GENERATOR	MARCONI	2042	119388/080	176	X
COMBINER	ELCOM	RC-4-50	N/A	170	X
ATTENUATOR	BIRD	8308-100	N/A	112	X

Intermodulation Inband

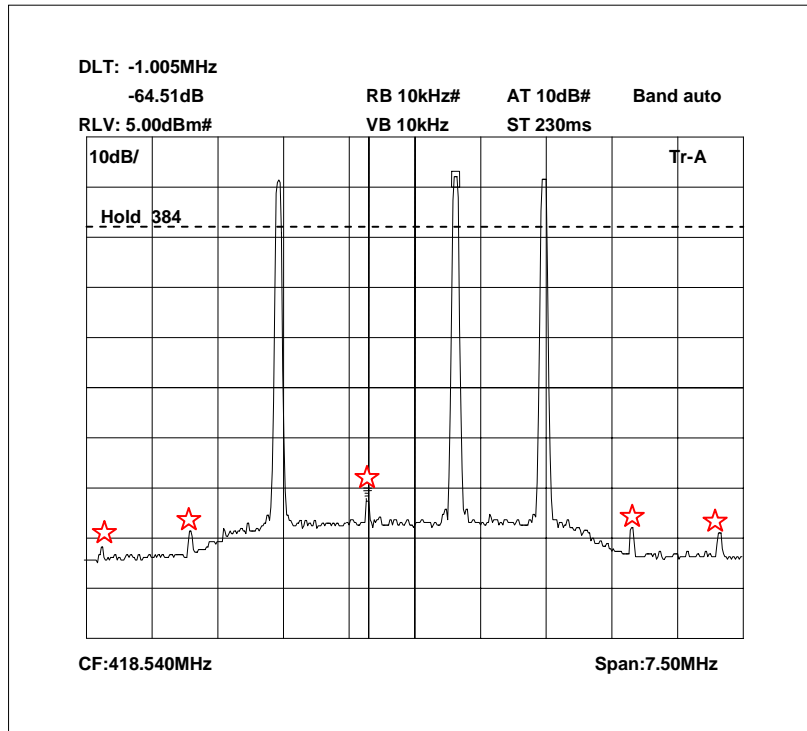

The above plot shows that all products (designated by ☆) are at least 40dB below the fundamentals.

Intermodulation Wideband

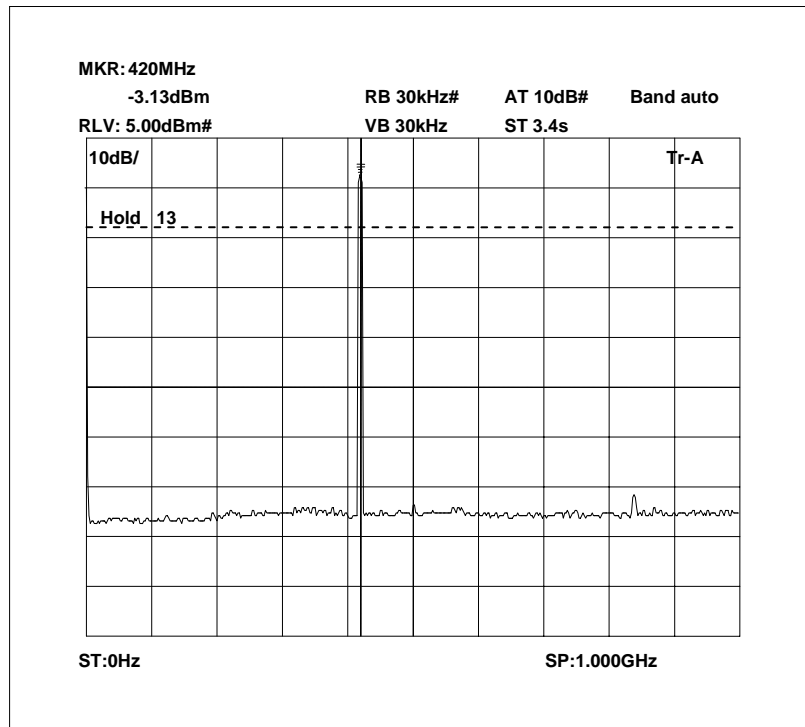

The above plot shows that there are no products outside the bands.

TRANSMITTER TESTS

AMPLIFIER MODULATED CHANNEL TEST – CONDUCTED – Part 2.1049– UPLINK

Ambient temperature = 23°C
 Relative humidity = 50%
 Supply voltage = +110 Vac
 Channel number = See test results

Radio Laboratory

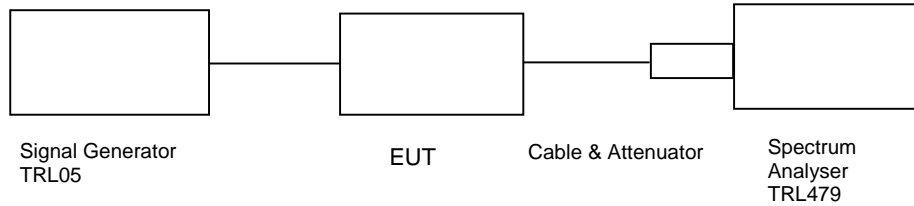

This test was performed to show that the amplifier does not alter the input signal in any way. The input signal was set to the maximum input level (-61.0dBm) and modulated with a 2500Hz tone. The plots show the signal measured at the signal generator and the signal measured at the output of the EUT.

Note: The cables and attenuators had the following losses.

1. Cable and attenuator between the EUT and signal generator 10.15dB
2. Cable between signal generator and EUT 0.3dB

TYPE OF EQUIPMENT	MAKER/SUPPLIER	MODEL No	SERIAL No	TRL No	ACTUAL EQUIPMENT USED
SPECTRUM ANALYSER	ANRITSU	MS2665C	MT26089	479	X
ATTENUATOR	BIRD	8308-100	N/A	112	X
CABLE	ROSENBERGER	MICRO COAX	N/A	280	X
SIGNAL GENERATOR	ROHDE & SCHWARZ	CMTA52	894715/033	05	X

417.0 MHz Signal Generator, deviation set to 5kHz

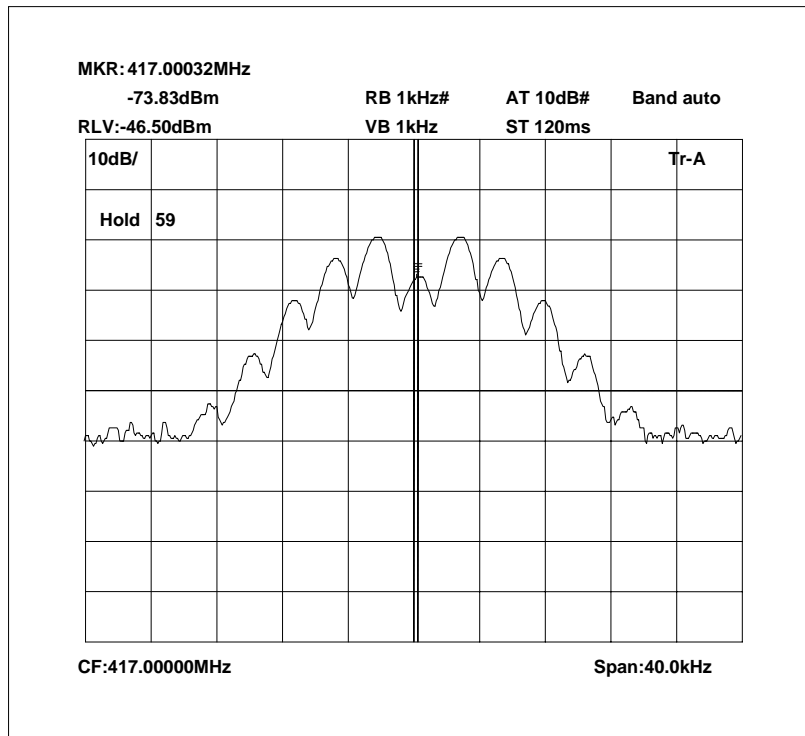

417.0 MHz Signal Generator and EUT, deviation set to 5kHz

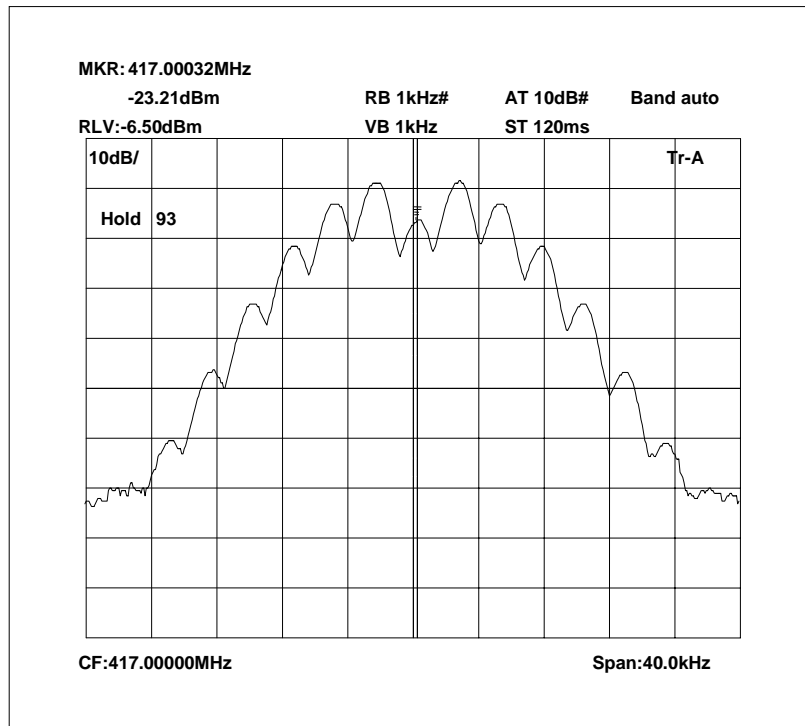

The above plots depicting the output waveshape show no measurable distortion visible when compared to the input signal.

418.5 MHz Signal Generator, deviation set to 5kHz

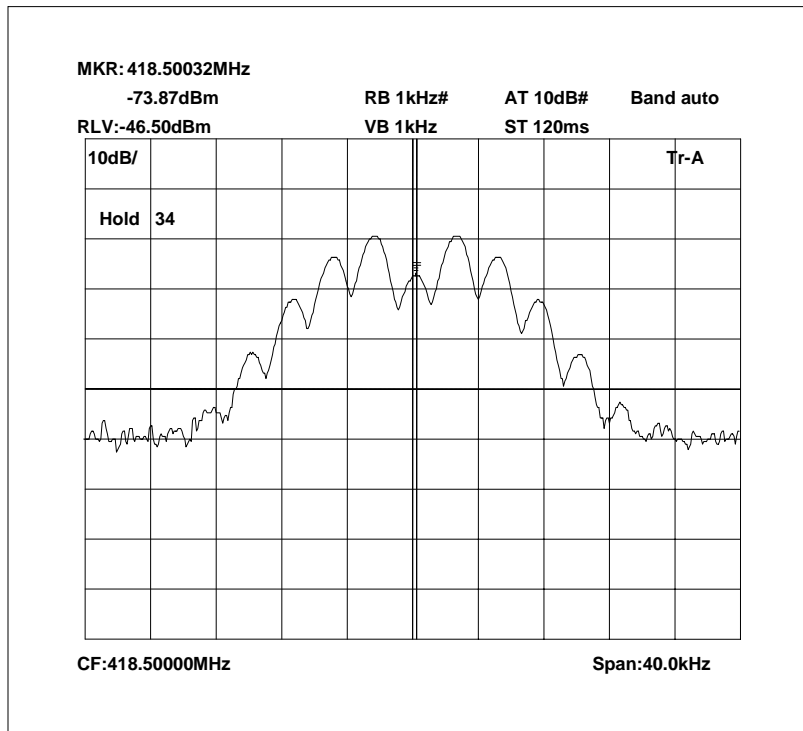

418.5 MHz Signal Generator and EUT, deviation set to 5kHz

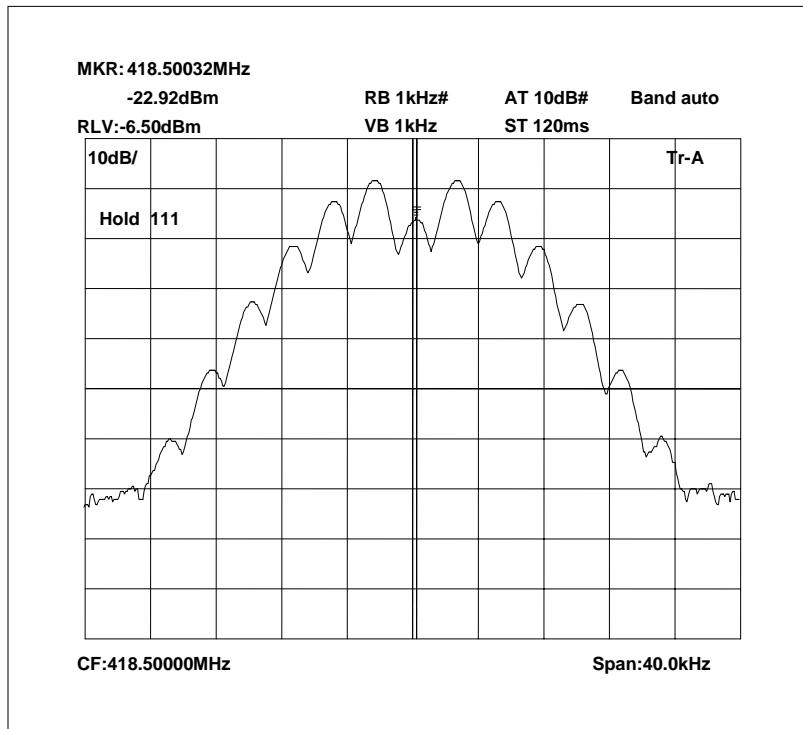

The above plots depicting the output waveshape show no measurable distortion visible when compared to the input signal.

420.0 MHz Signal Generator, deviation set to 5kHz

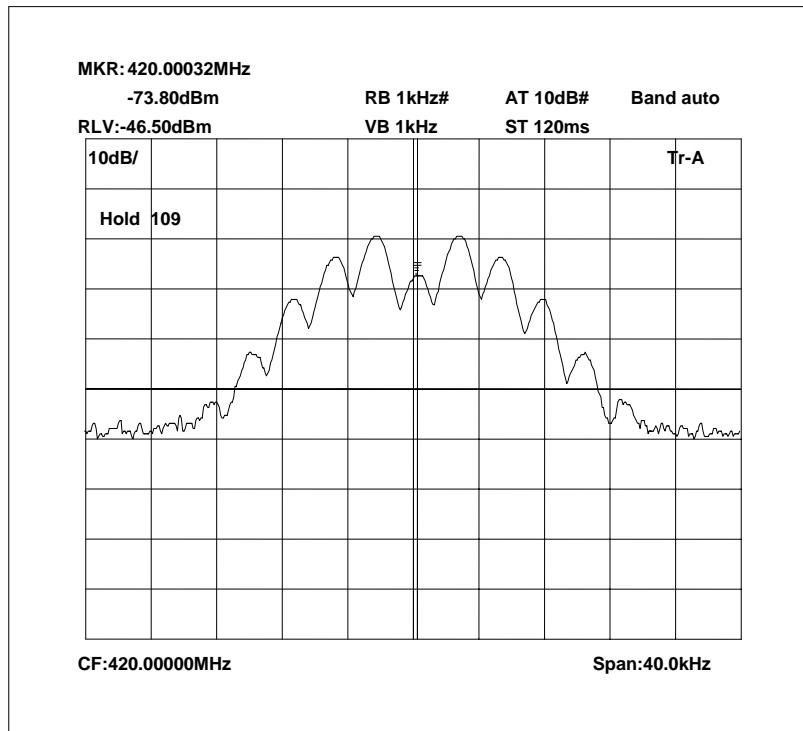

420.0 MHz Signal Generator and EUT, deviation set to 5kHz

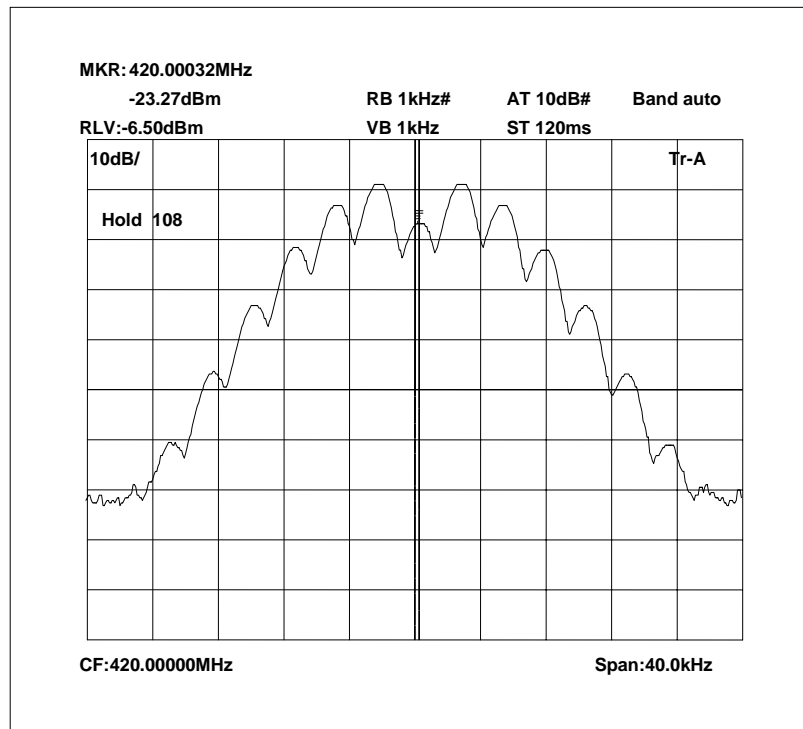

The above plots depicting the output waveshape show no measurable distortion visible when compared to the input signal.

TRANSMITTER TESTS

AMPLIFIER SPURIOUS EMISSIONS – CONDUCTED – Part 2.1053 – UPLINK

Ambient temperature = 22°C
 Relative humidity = 52%
 Supply voltage = +110 Vac

Radio Laboratory
 Test Signal = F3E

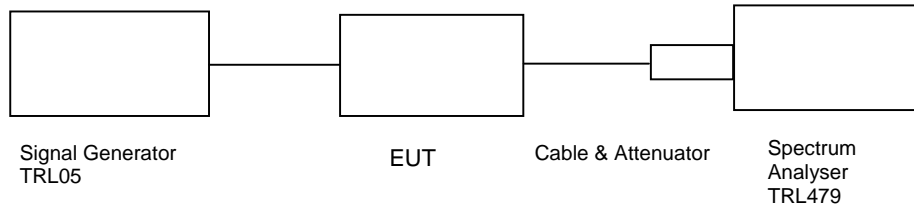

The test was set up as per the diagram. The level at the input was adjusted to compensate for the loss of the interconnecting cable. The unit was tested operating at maximum power and on three test frequencies.

The Spurious limit was calculated as follows:

On any frequency removed from the assigned frequency by more than 250% of the authorised bandwidth

At least $43 + 10 \log \text{PdB}$

$$(10 \log P_{\text{watts}}) - (43 + 10 \log (P_{\text{watts}} * 1000)) = \text{LIMIT} = -13 \text{ dBm}$$

RESULTS

FREQUENCY RANGE	FREQ. (MHz)	MEASURED LEVEL (dBm)	ATTENUATOR & CABLE LOSSES (dB)	EMISSION LEVEL (dBm)	LIMIT (dBm)
0Hz – 4.5GHz	No Significant Emissions within 10dBs of the Limit				-13

The test equipment used for the Transmitter Conducted Emissions:

TYPE OF EQUIPMENT	MAKER/SUPPLIER	MODEL No	SERIAL No	TRL No	ACTUAL EQUIPMENT USED
SPECTRUM ANALYSER	ANRITSU	MS2665C	MT26089	479	X
ATTENUATOR	BIRD	8308-100	N/A	112	X
CABLE	ROSENBERGER	MICRO COAX	N/A	280	X
SIGNAL GENERATOR	ROHDE & SCHWARZ	CMTA52	894715/033	05	X

Conducted emissions 417.0 MHz 0 – 2.25GHz

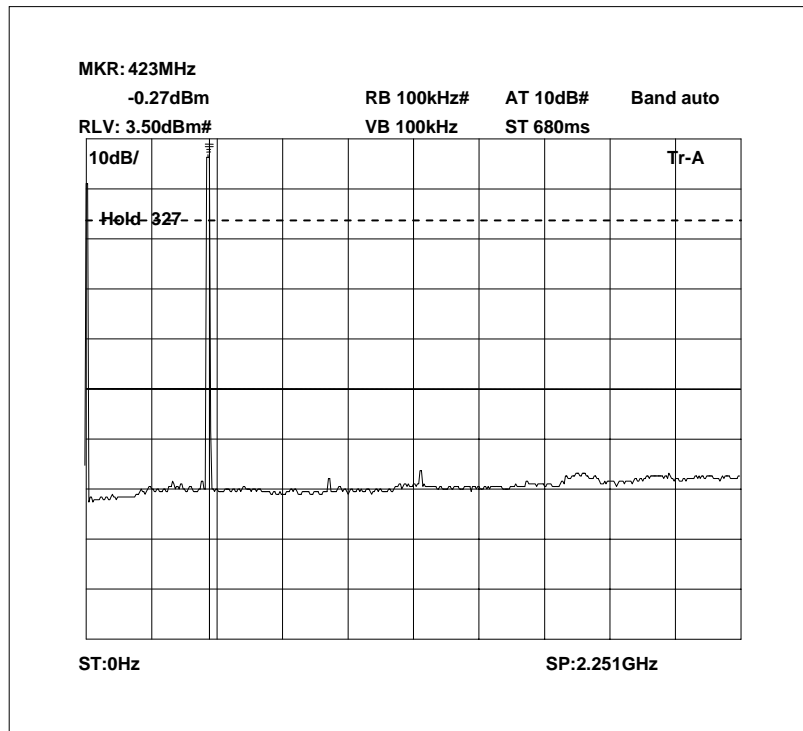

Conducted emissions 417.0 MHz 2.25– 4.5GHz

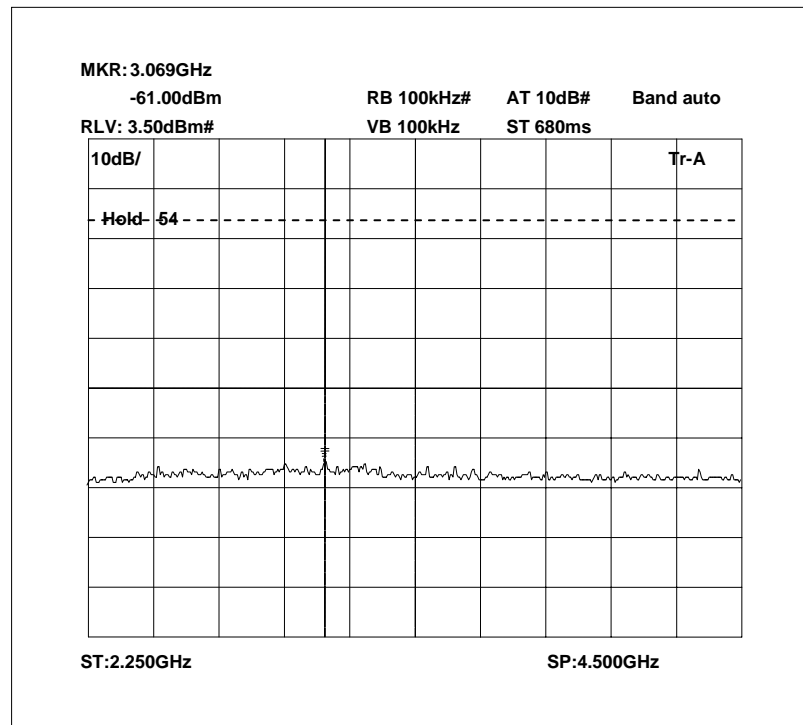

Conducted emissions 418.5 MHz 0 – 2.25GHz

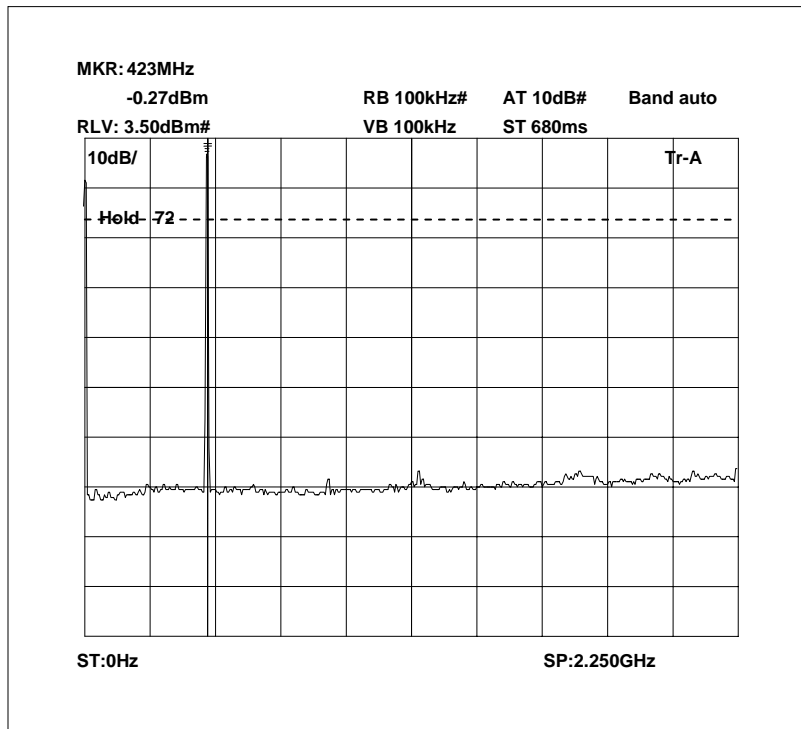

Conducted emissions 418.5 MHz 2.25 – 4.5GHz

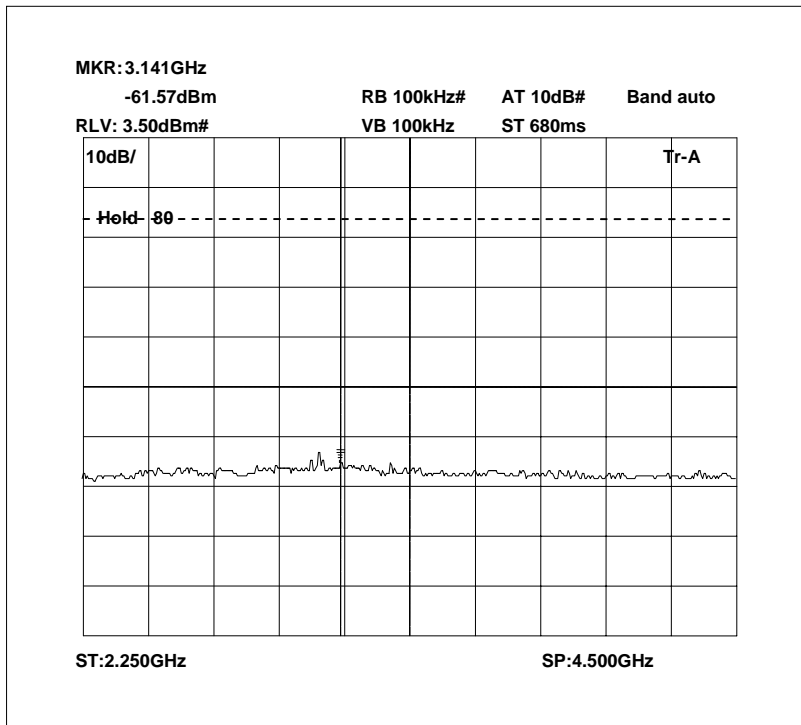

Conducted emissions 420.0 MHz 0 – 2.25GHz

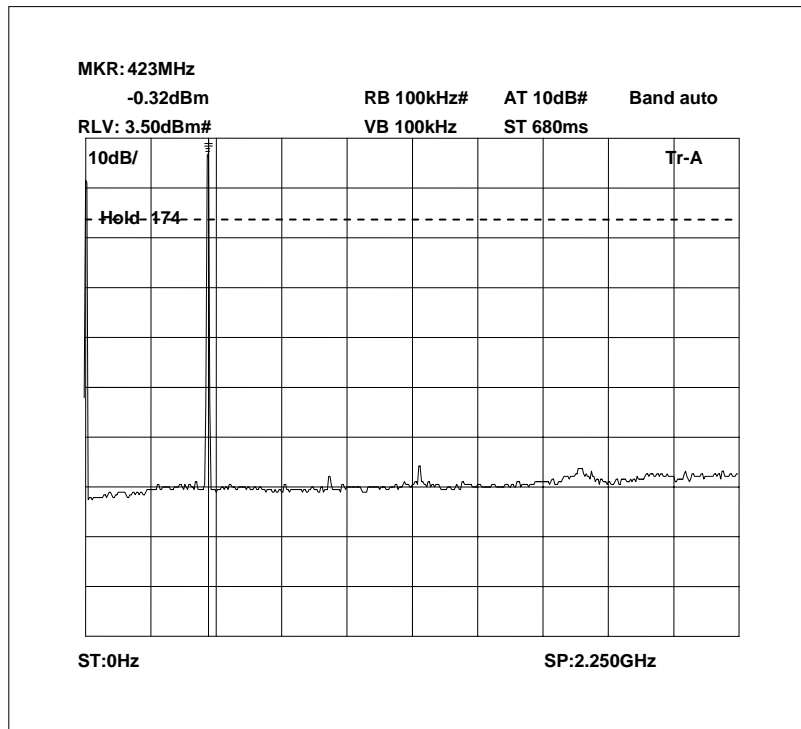

Conducted emissions 420.0 MHz 2.25 – 4.5GHz

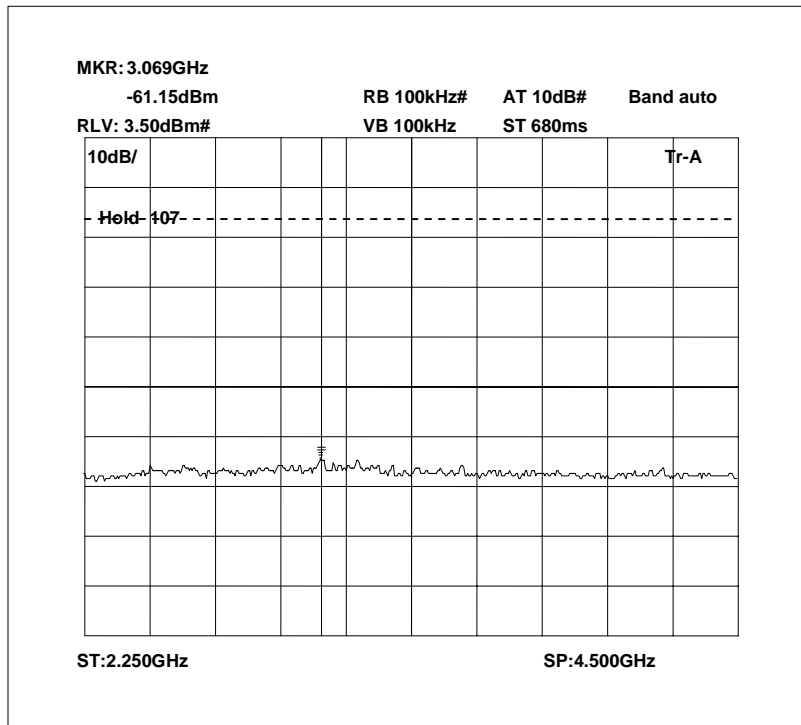

TRANSMITTER TESTS

AMPLIFIER SPURIOUS EMISSIONS – RADIATED – Part 2.1053– UPLINK

Ambient temperature = 18°C
 Relative humidity = 55%
 Conditions = OATS
 Supply voltage = +110 Vac
 Supply Frequency = N/A

Test Signal = F3E

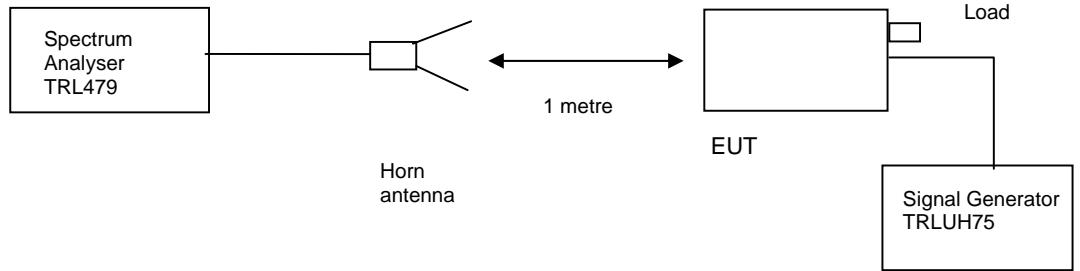

The test was set up as per the diagram. The level at the input was adjusted to compensate for the loss of the interconnecting cable. The unit was tested operating maximum power on three test frequencies with a 50 ohm load on the output. The unit was also tested with the signal generator replaced by another 50ohm load.

The Spurious limit was calculated as follows:

On any frequency removed from the assigned frequency by more that 250% of the authorised bandwidth

At least 43 + 10 log PdB

$$(10\log P_{\text{watts}}) - (43+10\log (P_{\text{watts}} * 1000)) = \text{LIMIT} = -13 \text{ dBm}$$

RESULTS

FREQUENCY RANGE	FREQ. (MHz)	MEAS. Rx. (dBµV)	CABLE LOSS (dB)	ANT FACTOR	FIELD STRENGTH (dBµV/m)	CALCULATED EIRP (dBm)	LIMIT (dBm)
0Hz – 4.5GHz	No Significant Emissions within 10dBs of the Limit						-13dBm

The test equipment used for the Transmitter Spurious Emissions:

TYPE OF EQUIPMENT	MAKER/ SUPPLIER	MODEL No	SERIAL No	TRL No	ACTUAL EQUIPMENT USED
SPECTRUM ANALYSER	ANRITSU	MS2665C	MT26089	479	X
HORN	EMCO	3115	9010-3581	139	X
CABLE	ROSENBERGER	MICRO COAX	N/A	280	X
SIGNAL GENERATOR	MARCONI	2022D	119215/058	UH75	X

Radiated emissions 417.0 MHz 0 – 2.25GHz

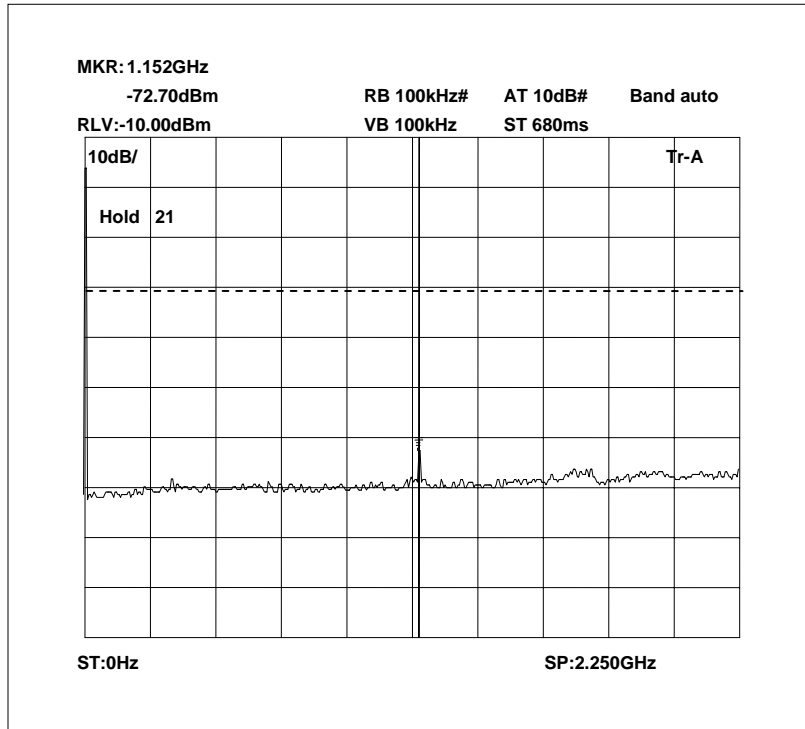

Radiated emissions 417.0 MHz 2.25 – 4.5GHz

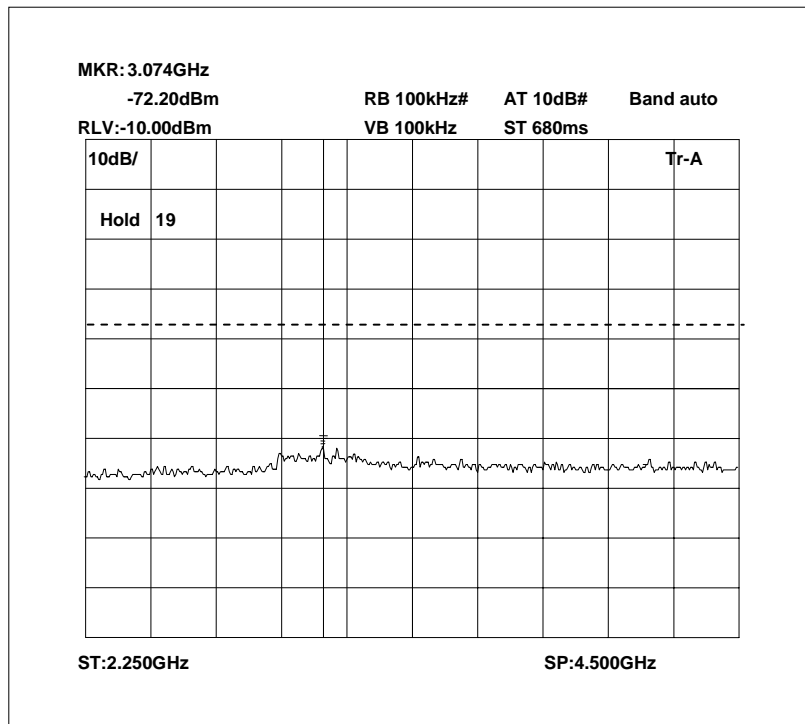

The above test results show that there were no emissions within 20dBs of the -13dBm limit.

Radiated emissions 418.5 MHz 0 – 2.25GHz

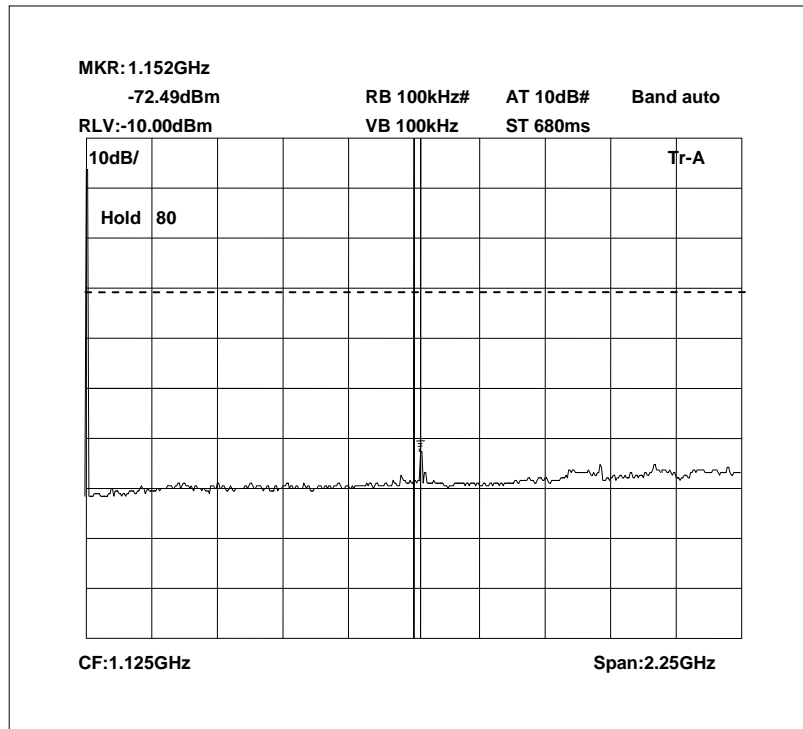

Radiated emissions 418.5 MHz 2.25 – 4.5GHz

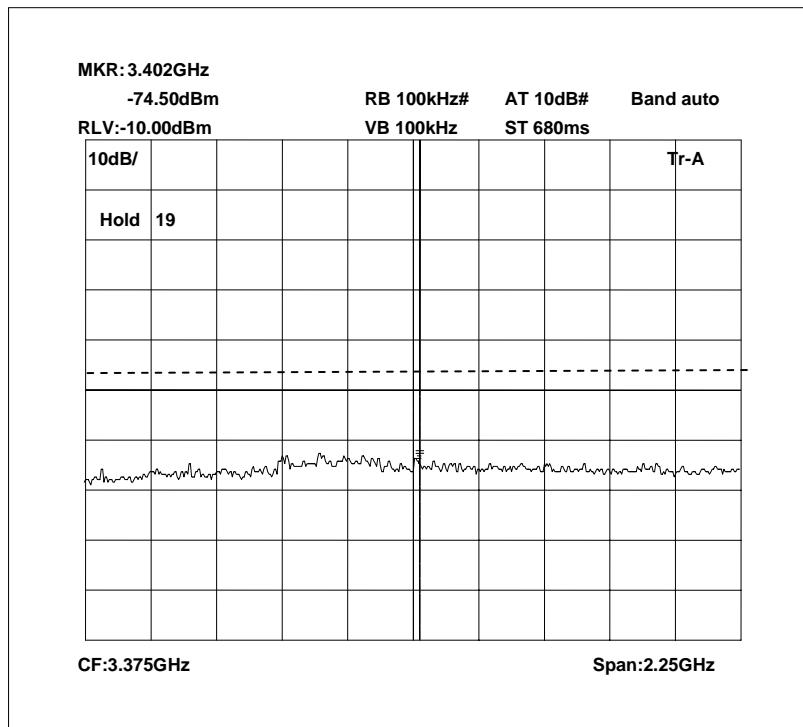

The above test results show that there were no emissions within 20dBs of the -13dBm limit.

Radiated emissions 420.0 MHz 0 – 2.25GHz

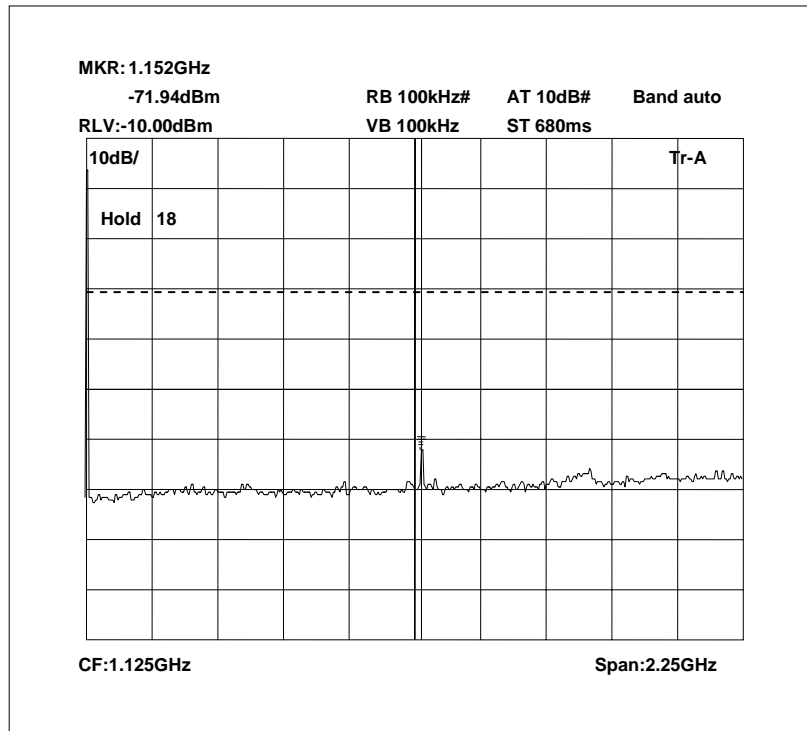

Radiated emissions 420.0 MHz 2.25 – 4.5GHz

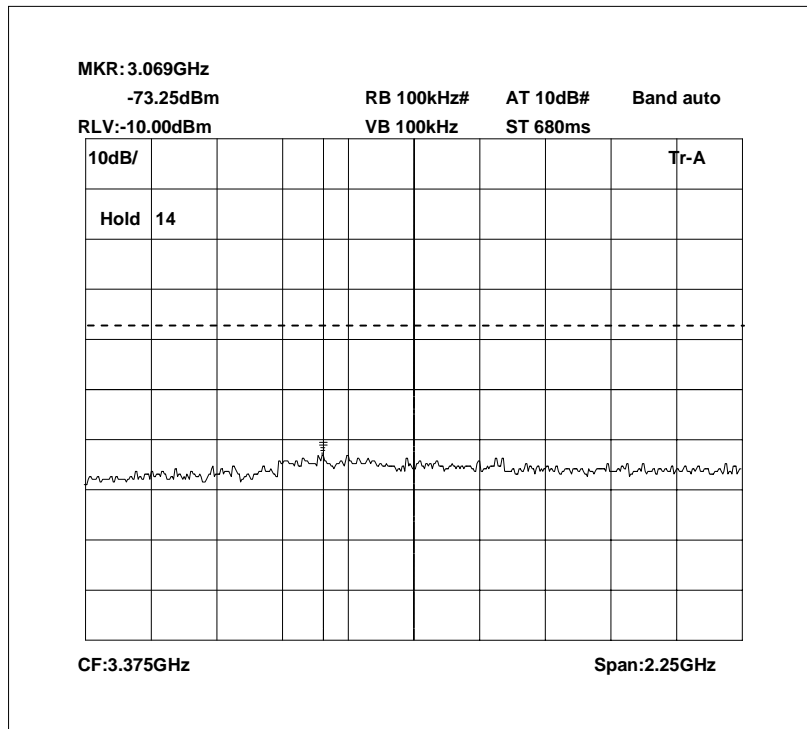

The above test results show that there were no emissions within 20dBs of the -13dBm limit.

Radiated emissions no input signal 0 – 2.25GHz

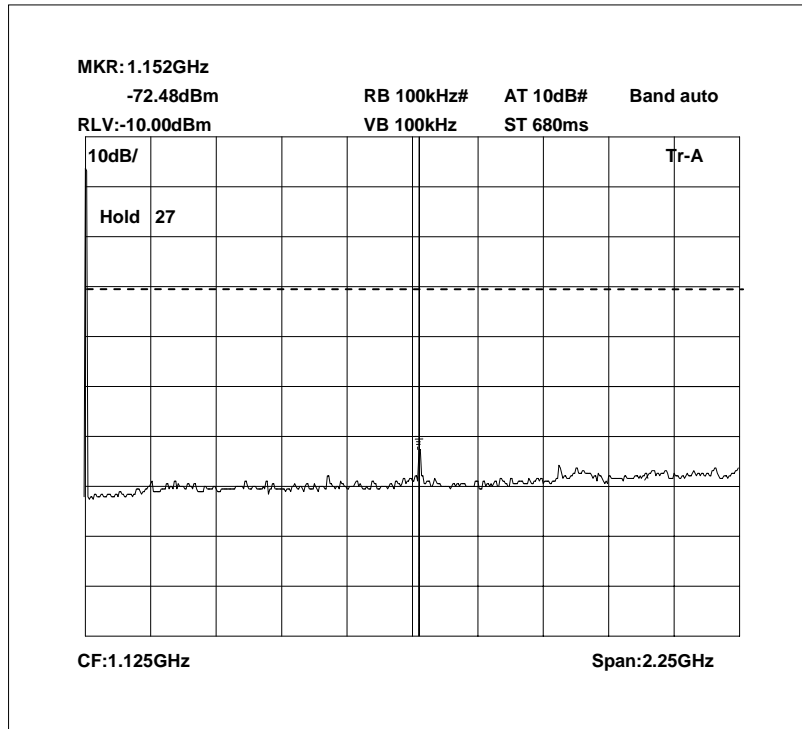

Radiated emissions no input signal 2.25 – 4.5GHz

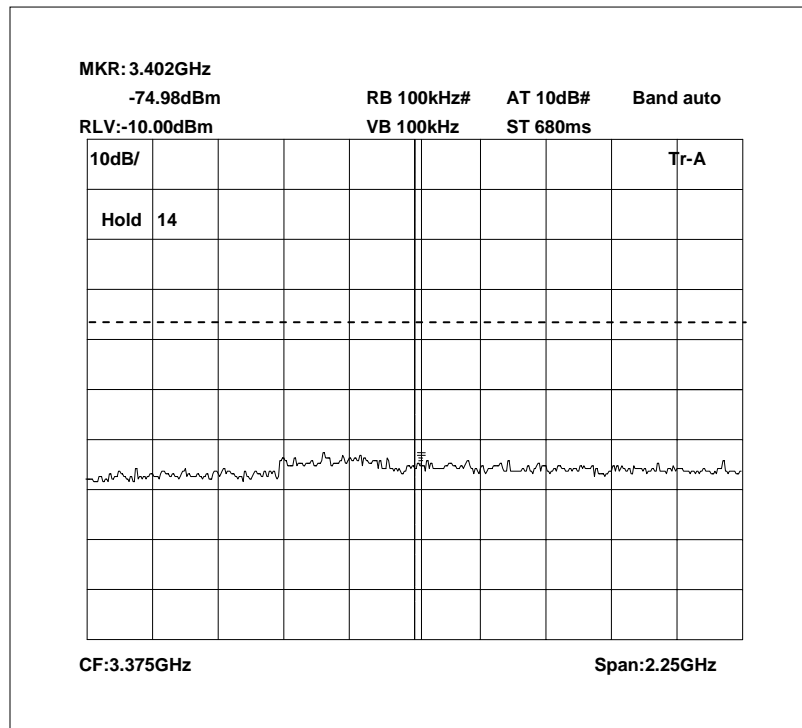

The above test results show that there were no emissions within 20dBs of the -13dBm limit.

AMPLIFIER GAIN – CONDUCTED – PART 2.1046 – DOWNLINK

Ambient temperature = 18°C
 Relative humidity = 56%
 Supply voltage = +110 Vac
 Channel number = See test results

Radio Laboratory

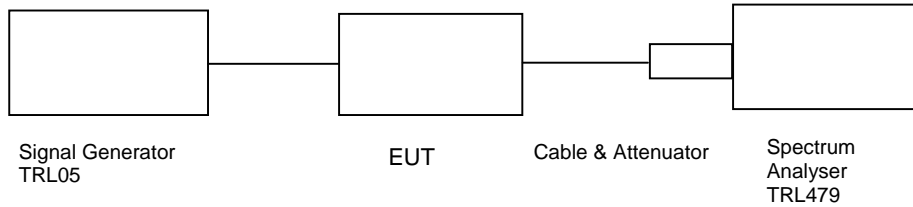

Frequency MHz	Signal Generator input level dBm	Cable & Attenuator loss dB	Level at Spectrum Analyser dBm	Gain dB	Output Power dBm	Gain after 10dB input level increase dBm
408.0	-19.3	40.6	0.00	59.90	40.60	51.84
409.5	-21.3	40.6	-0.98	60.92	39.62	52.91
411.0	-19.3	40.6	-0.31	59.59	40.29	51.58

Notes:

1. The level of the signal generator takes into consideration the loss from the cable.
2. The signal generator input was increased by 10dBs and the level of the output signal remeasured

TYPE OF EQUIPMENT	MAKER/SUPPLIER	MODEL No	SERIAL No	TRL No	ACTUAL EQUIPMENT USED
SPECTRUM ANALYSER	ANRITSU	MS2665C	MT26089	479	X
ATTENUATOR	SPINNER	745357	D 37224	UH225	X
ATTENUATOR	BIRD	8308-200	N/A	103	X
CABLE	ROSENBERGER	MICRO COAX	N/A	280	X
CMTA	ROHDE & SCHWARZ	CMTA52	894715/033	05	X

AMPLIFIER INTERMODULATION SPURIOUS EMISSIONS – CONDUCTED – PART 2.1053– DOWNLINK

Ambient temperature = 18°C
 Relative humidity = 56%
 Supply voltage = +110 Vac

Radio Laboratory

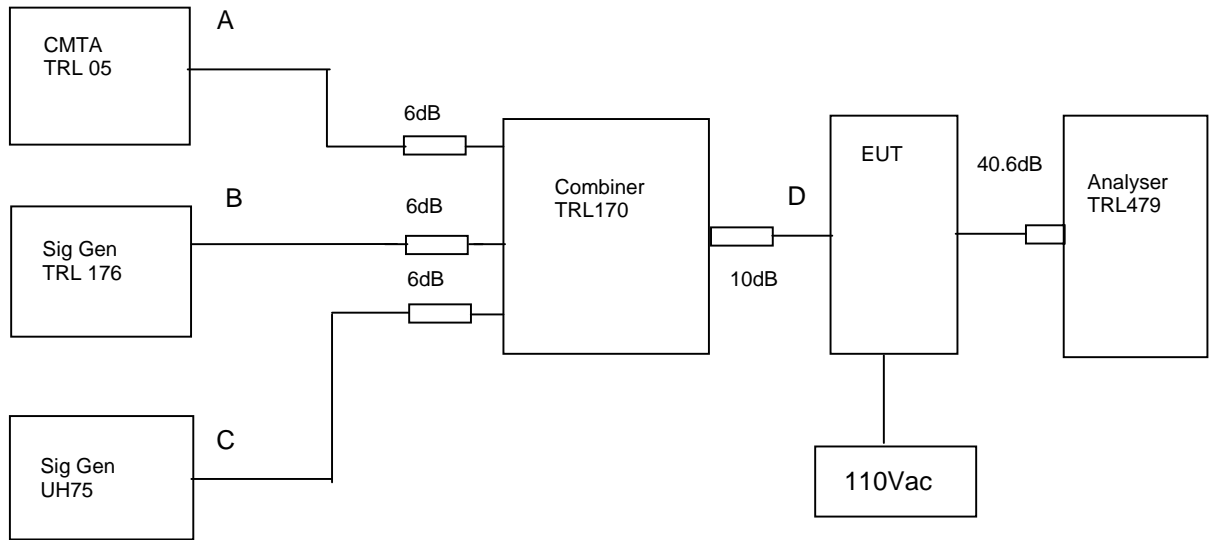

The Intermodulation and spurious products were measured with the amplifier operating at maximum gain. A three tone test was conducted using the equipment as above. The input power level was adjusted so the level at point D was 10 dB above the maximum input of -19.0dBm. The cable and attenuators loss between the EUT and the spectrum analyser was 40.6 dB.

RF Input Frequency (MHz)			Highest Intermodulation Product Level (dBm)	Limit (dBm)
408.0	409.0	411.0	-25.31dBm @ 410.0 MHz	-13

Sweep data is shown on the next page:

Test equipment used for intermodulation test

TYPE OF EQUIPMENT	MAKER/SUPPLIER	MODEL No	SERIAL No	TRL No	ACTUAL EQUIPMENT USED
SPECTRUM ANALYSER	ANRITSU	MS2665C	MT26089	479	X
SIGNAL GENERATOR	MARCONI	2022D	119215/058	UH75	X
CMTA	ROHDE & SCHWARZ	CMTA52	894715/033	05	X
SIGNAL GENERATOR	MARCONI	2042	119388/080	176	X
COMBINER	ELCOM	RC-4-50	N/A	170	x

Intermodulation Inband

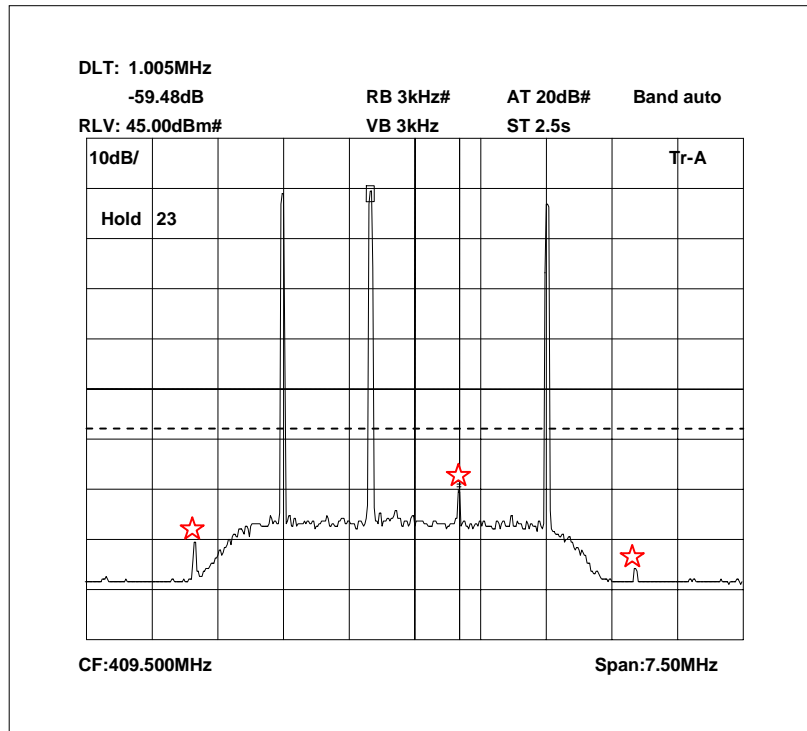

The above plot shows that all products (designated by ☆) are at least 50dB below the fundamentals.

Intermodulation Wideband

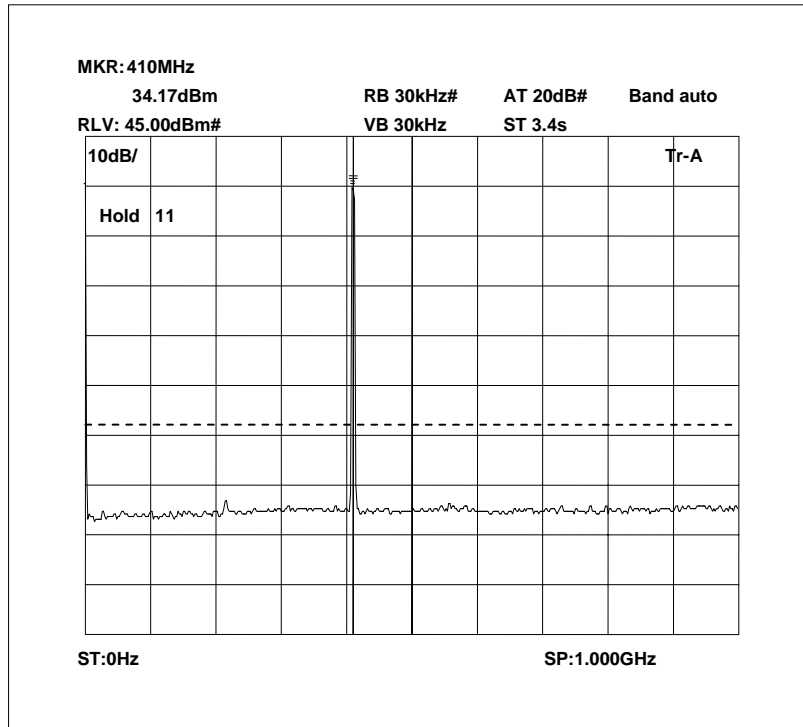

The above plot shows that there are no products outside the bands.

TRANSMITTER TESTS

AMPLIFIER MODULATED CHANNEL TEST – CONDUCTED – Part 2.1049– DOWNLINK

Ambient temperature = 18°C
 Relative humidity = 57%
 Supply voltage = +110 Vac
 Channel number = See test results

Radio Laboratory

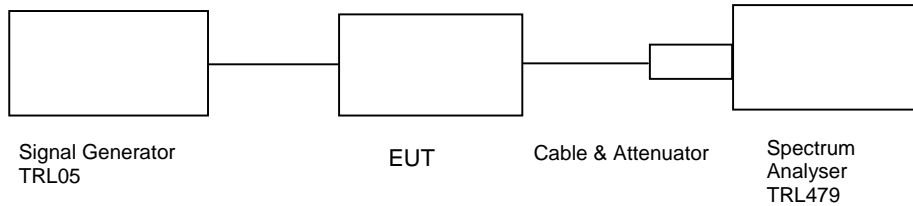

This test was performed to show that the amplifier does not alter the input signal in any way. The input signal was set to the maximum input level (-19dBm) and modulated with a 2500Hz tone. The plots show the signal measured at the signal generator and the signal measured at the output of the EUT.

Note: The cables and attenuators had the following losses.

1. Cable and attenuator between EUT and pectrum analyser = 40.6dB
2. Cable between signal generator and EUT = 0.3dB

TYPE OF EQUIPMENT	MAKER/SUPPLIER	MODEL No	SERIAL No	TRL No	ACTUAL EQUIPMENT USED
SPECTRUM ANALYSER	ANRITSU	MS2665C	MT26089	479	X
ATTENUATOR	SPINNER	745357	D 37224	UH225	X
ATTENUATOR	BIRD	8308-200	N/A	103	X
CABLE	ROSENBERGER	MICRO COAX	N/A	280	X
CMTA	ROHDE & SCHWARZ	CMTA52	894715/033	05	X

408.0 MHz Signal Generator, deviation set to 5kHz

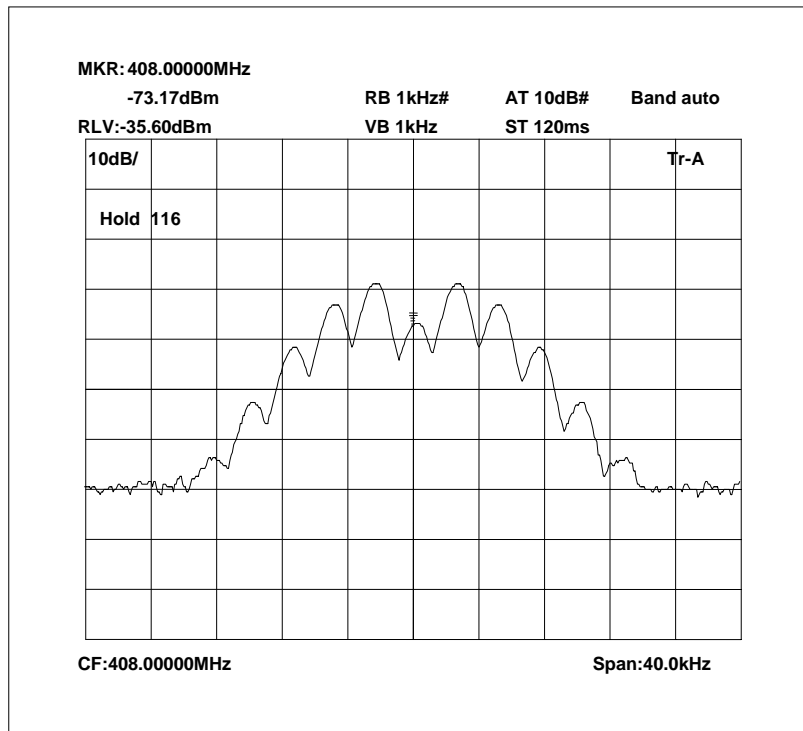

408.0 MHz Signal Generator and EUT, deviation set to 5kHz

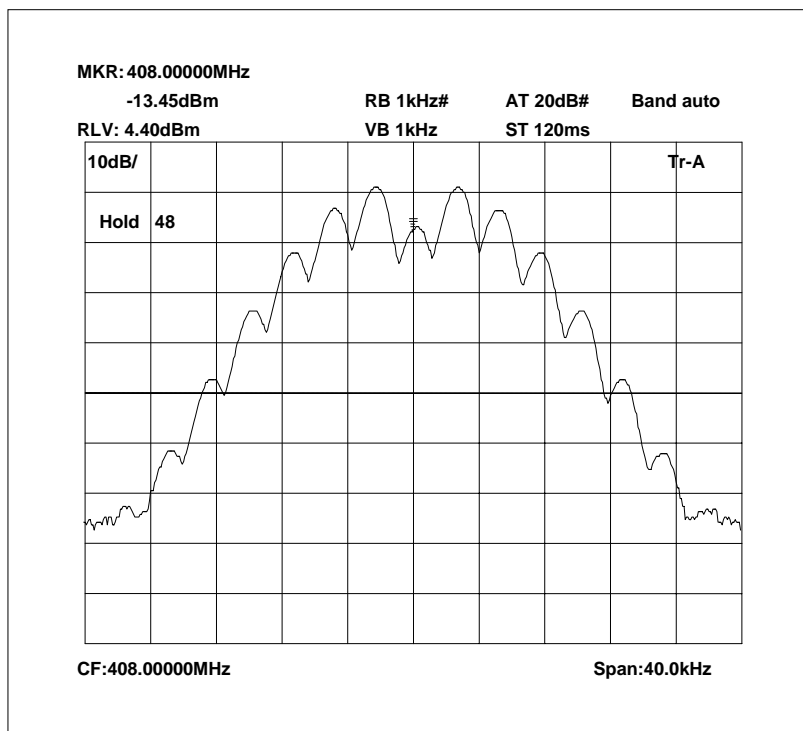

The above plots depicting the output waveshape show no measurable distortion visible when compared to the input signal.

409.5 MHz Signal Generator, deviation set to 5kHz

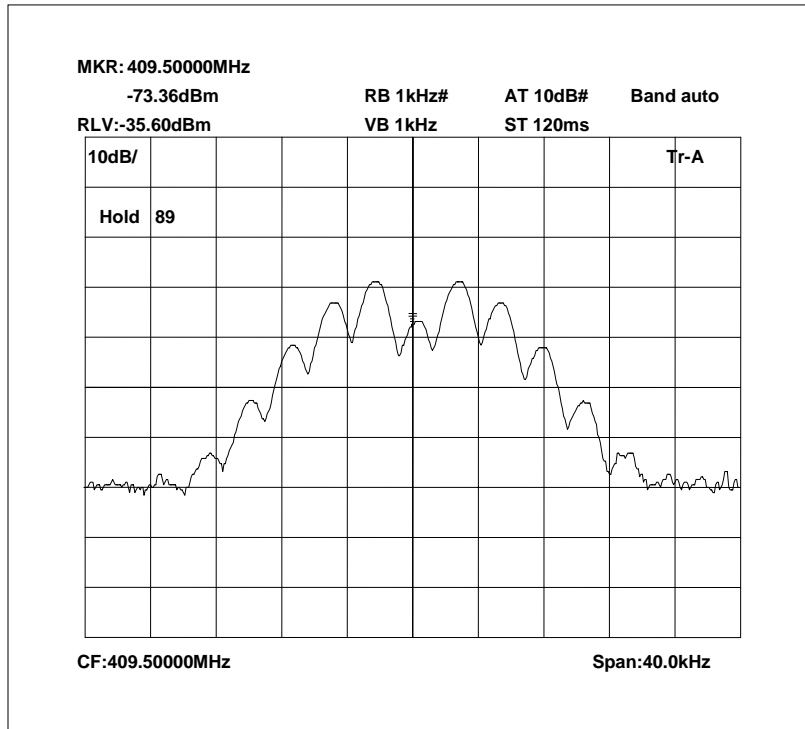

409.5 MHz Signal Generator and EUT, deviation set to 5kHz

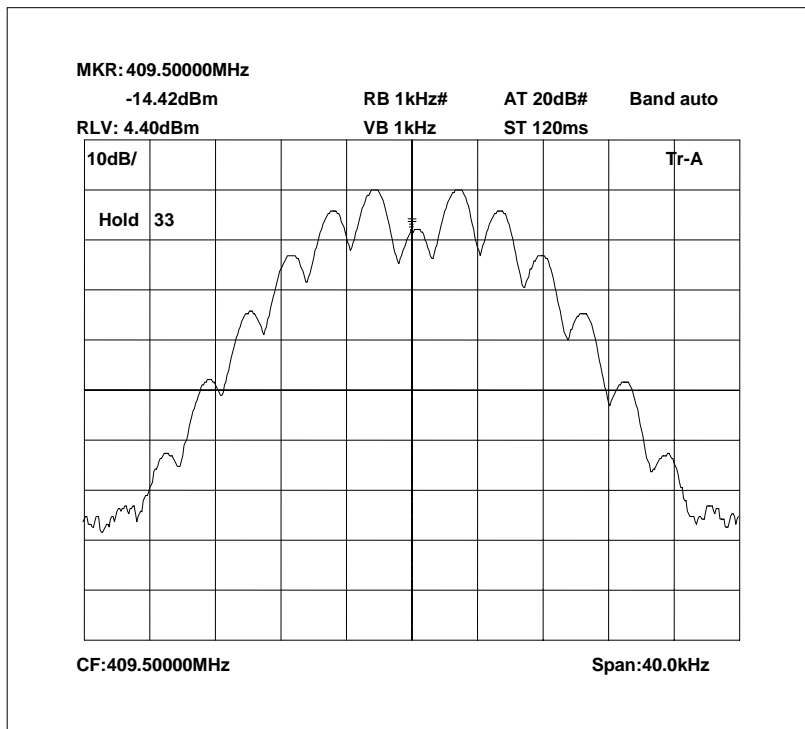

The above plots depicting the output waveshape show no measurable distortion visible when compared to the input signal.

411.0 MHz Signal Generator, deviation set to 5kHz

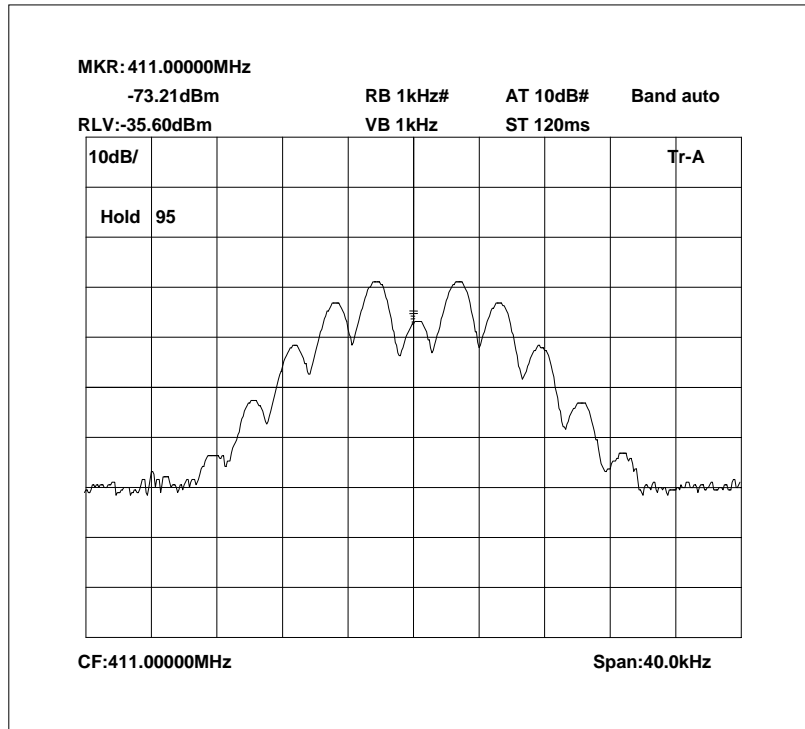

411.0 MHz Signal Generator and EUT, deviation set to 5kHz

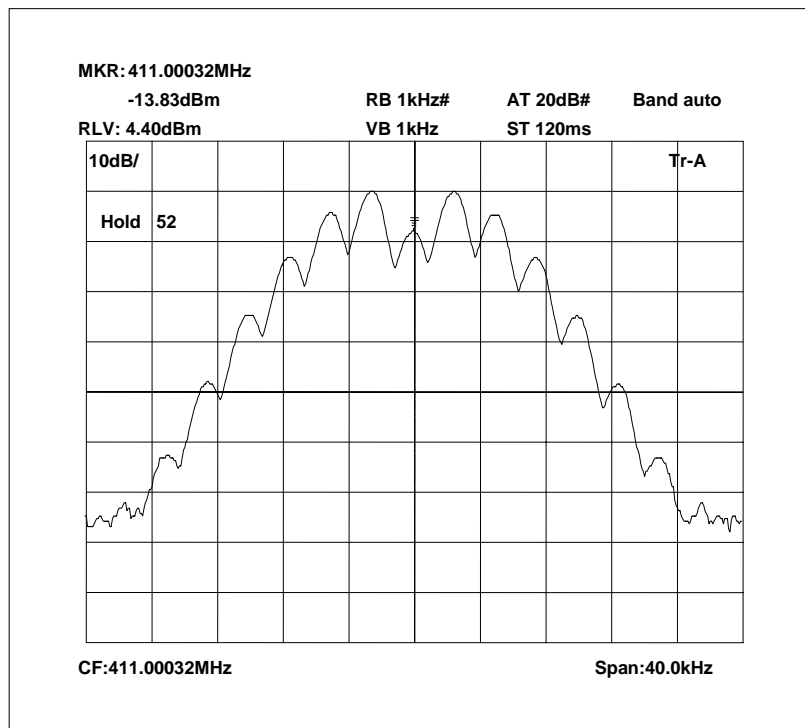

The above plots depicting the output waveshape show no measurable distortion visible when compared to the input signal.

TRANSMITTER TESTS

AMPLIFIER SPURIOUS EMISSIONS – CONDUCTED – Part 2.1053 – DOWNLINK

Ambient temperature = 15°C
 Relative humidity = 60%
 Supply voltage = +110 Vac

Radio Laboratory
 Test Signal = F3E

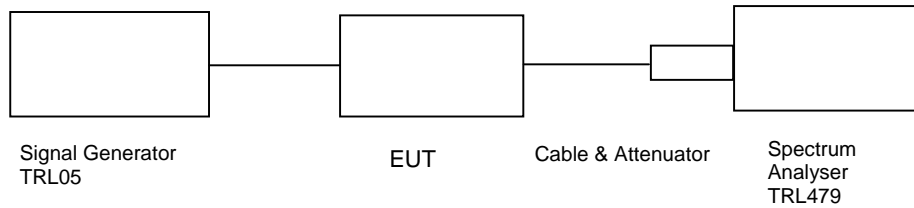

The test was set up as per the diagram. The level at the input was adjusted to compensate for the loss of the interconnecting cable. The unit was tested operating at maximum power and on three test frequencies.

The Spurious limit was calculated as follows:

On any frequency removed from the assigned frequency by more than 250% of the authorised bandwidth

At least $43 + 10 \log P_{dB}$

$$(10 \log P_{\text{watts}}) - (43 + 10 \log (P_{\text{watts}} * 1000)) = \text{LIMIT} = -13 \text{ dBm}$$

RESULTS

FREQUENCY RANGE	FREQ. (MHz)	MEASURED LEVEL (dBm)	ATTENUATOR & CABLE LOSSES (dB)	EMISSION LEVEL (dBm)	LIMIT (dBm)
0Hz – 4 GHz	No Significant Emissions within 10dB of the Limit				-13

The test equipment used for the Transmitter Conducted Emissions:

TYPE OF EQUIPMENT	MAKER/SUPPLIER	MODEL No	SERIAL No	TRL No	ACTUAL EQUIPMENT USED
SPECTRUM ANALYSER	ANRITSU	MS2665C	MT26089	479	X
ATTENUATOR	SPINNER	745357	D 37224	UH225	X
ATTENUATOR	BIRD	8308-200	N/A	103	X
CABLE	ROSENBERGER	MICRO COAX	N/A	280	X
CMTA	ROHDE & SCHWARZ	CMTA52	894715/033	05	X

Conducted emissions 408.0 MHz 0 – 2.25GHz

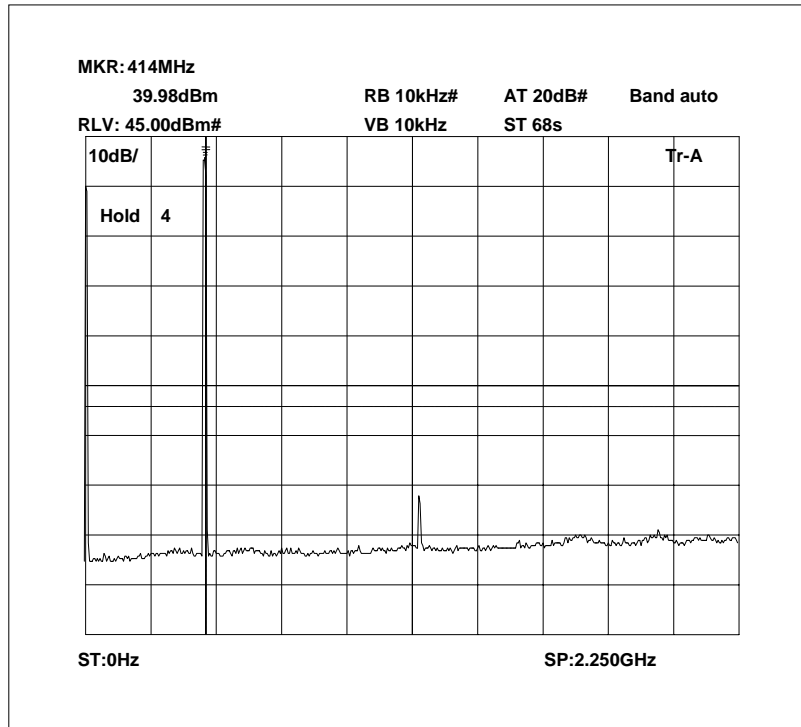

Conducted emissions 408.0 MHz 2.25 – 4.5GHz

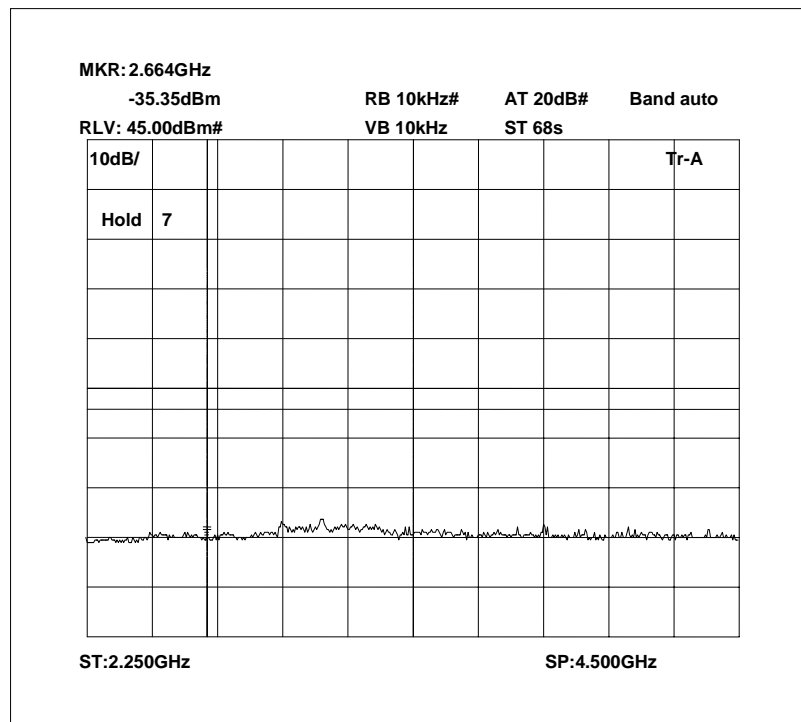

Conducted emissions 409.5 MHz 0 – 2.25GHz

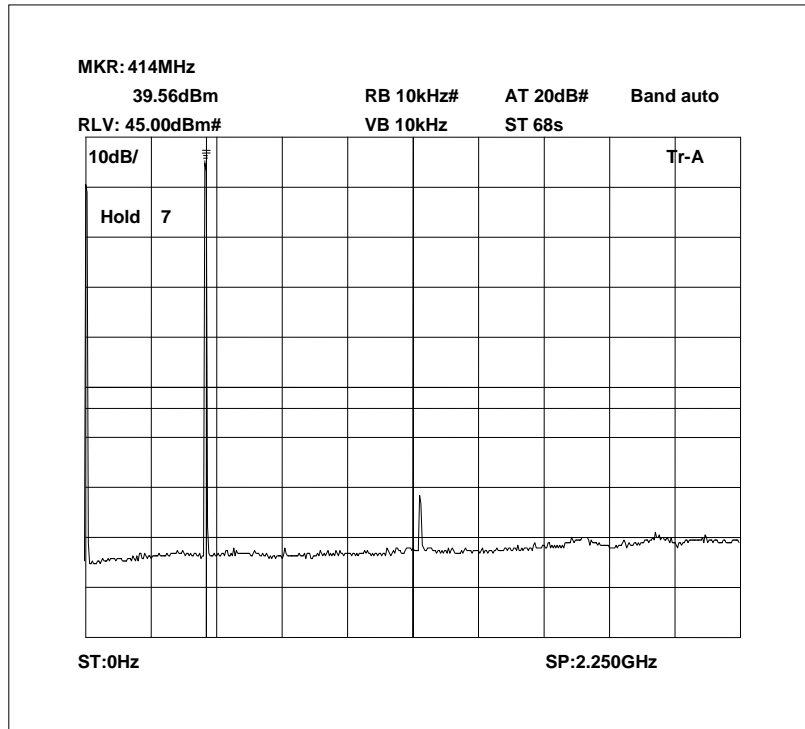

Conducted emissions 409.5 MHz 2.25 – 4.5GHz

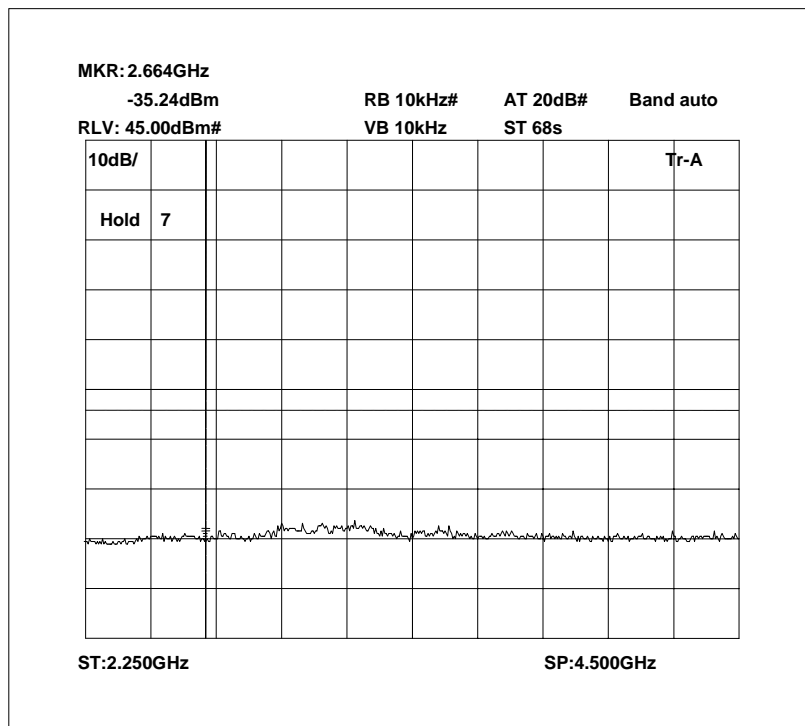

Conducted emissions 411.0 MHz 0 – 2.25GHz

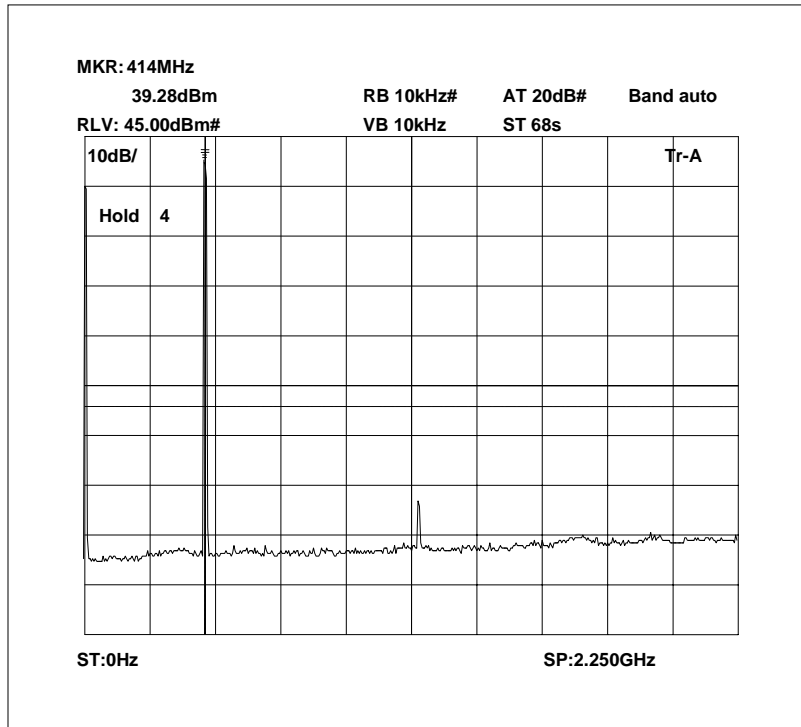

Conducted emissions 411.0 MHz 2.25 – 4.5GHz

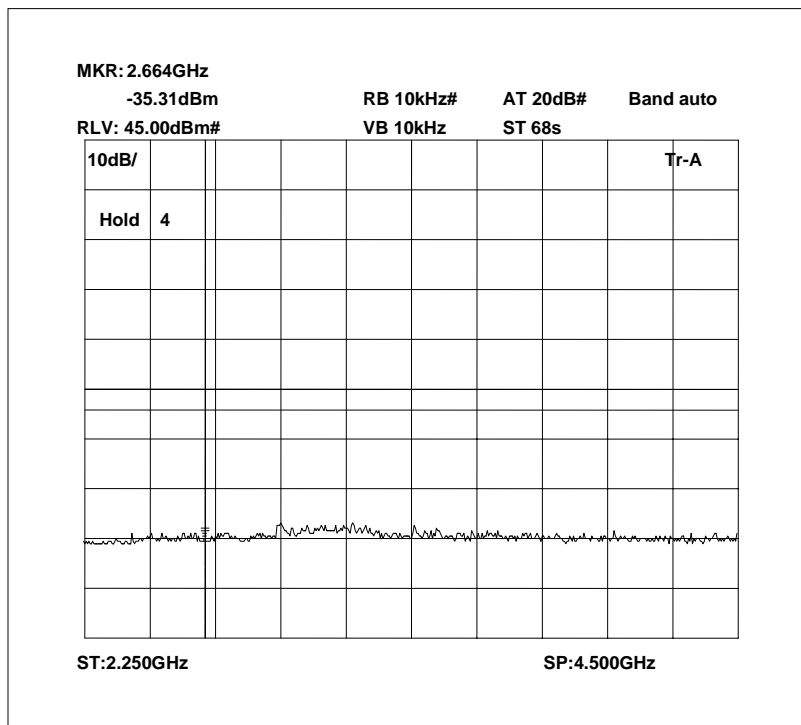

TRANSMITTER TESTS

AMPLIFIER SPURIOUS EMISSIONS – RADIATED – Part 2.1053– DOWNLINK

Ambient temperature = 18°C
 Relative humidity = 55%
 Conditions = OATS
 Supply voltage = +110 Vac
 Supply Frequency = N/A

Test Signal = F3E

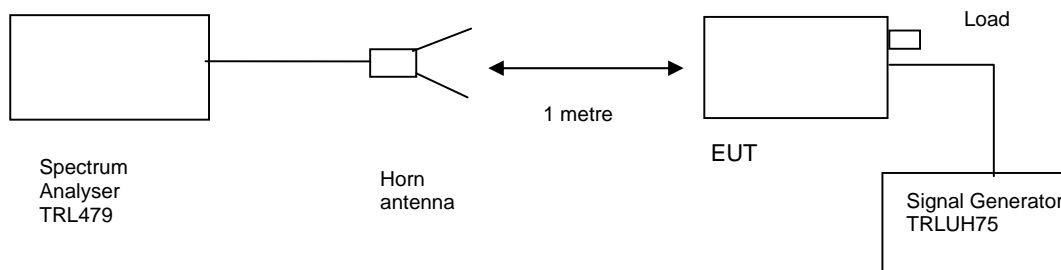

The test was set up as per the diagram. The level at the input was adjusted to compensate for the loss of the interconnecting cable. The unit was tested operating maximum power on three test frequencies with a 50 ohm load on the output. The unit was also tested with the signal generator replaced by another 50ohm load.

The Spurious limit was calculated as follows:

On any frequency removed from the assigned frequency by more that 250% of the authorised bandwidth

At least $43 + 10 \log P_{dB}$

$(10 \log P_{watts}) - (43 + 10 \log (P_{watts} * 1000)) = \text{LIMIT} = -13 \text{ dBm}$

RESULTS

FREQUENCY RANGE	FREQ. (MHz)	MEAS. Rx. (dBµV)	CABLE LOSS (dB)	ANT FACTOR	FIELD STRENGTH (dBµV/m)	CALCULATED EIRP (dBm)	LIMIT (dBm)
0Hz – 4.5GHz	No Significant Emissions Within 10dB of the Limit						-13

The test equipment used for the Transmitter Spurious Emissions:

TYPE OF EQUIPMENT	MAKER/SUPPLIER	MODEL No	SERIAL No	TRL No	ACTUAL EQUIPMENT USED
SPECTRUM ANALYSER	ANRITSU	MS2665C	MT26089	479	X
HORN	EMCO	3115	9010-3581	139	X
CABLE	ROSENBERGER	MICRO COAX	N/A	280	X
SIGNAL GENERATOR	MARCONI	2022D	119215/058	UH75	X

Radiated emissions 408.0 MHz 0 – 2.25GHz

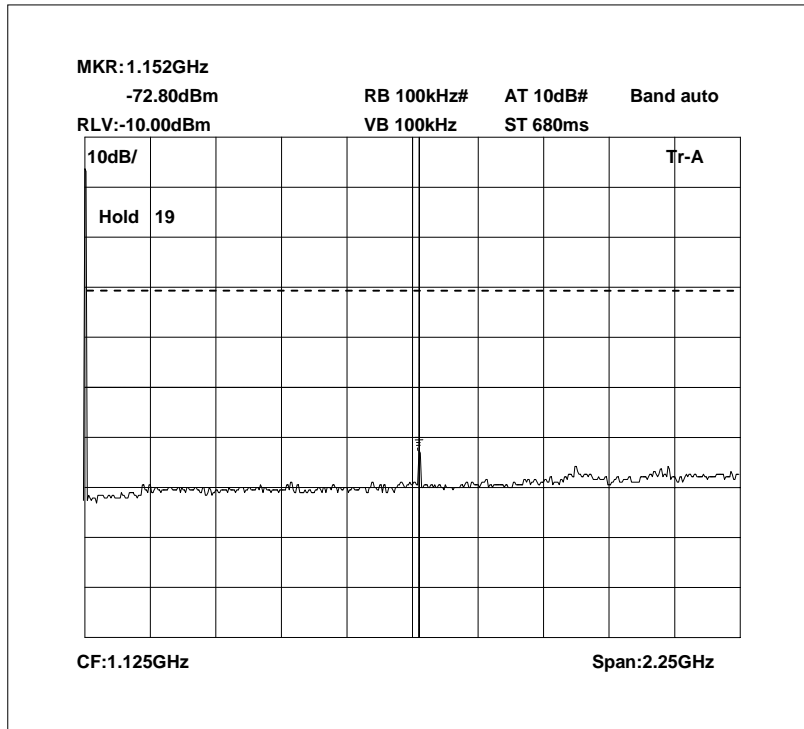

Radiated emissions 408.0 MHz 2.25 – 4.5GHz

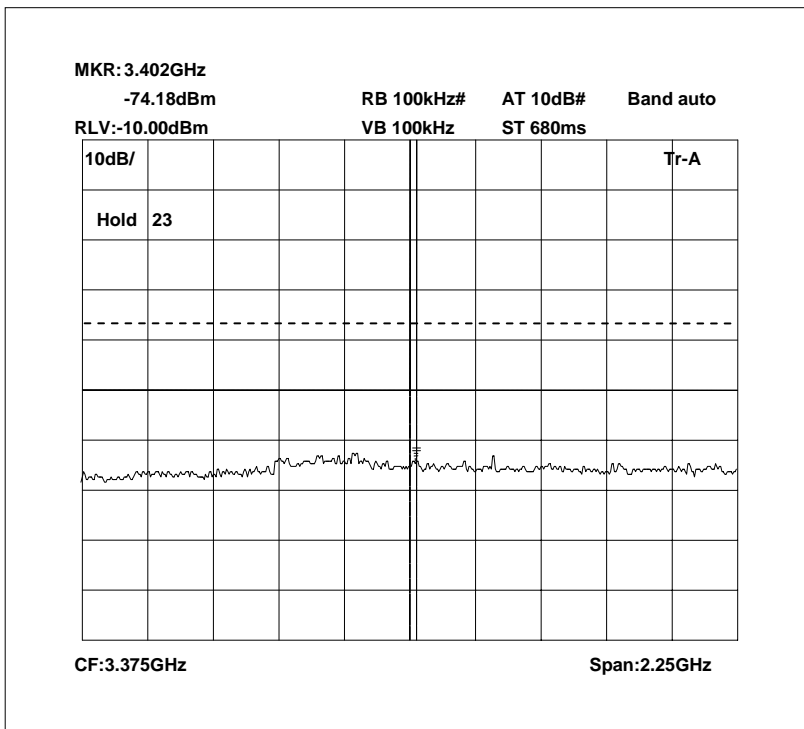

The above test results show that there were no emissions within 20dBs of the -13dBm limit.

Radiated emissions 409.5 MHz 0 – 2.25GHz

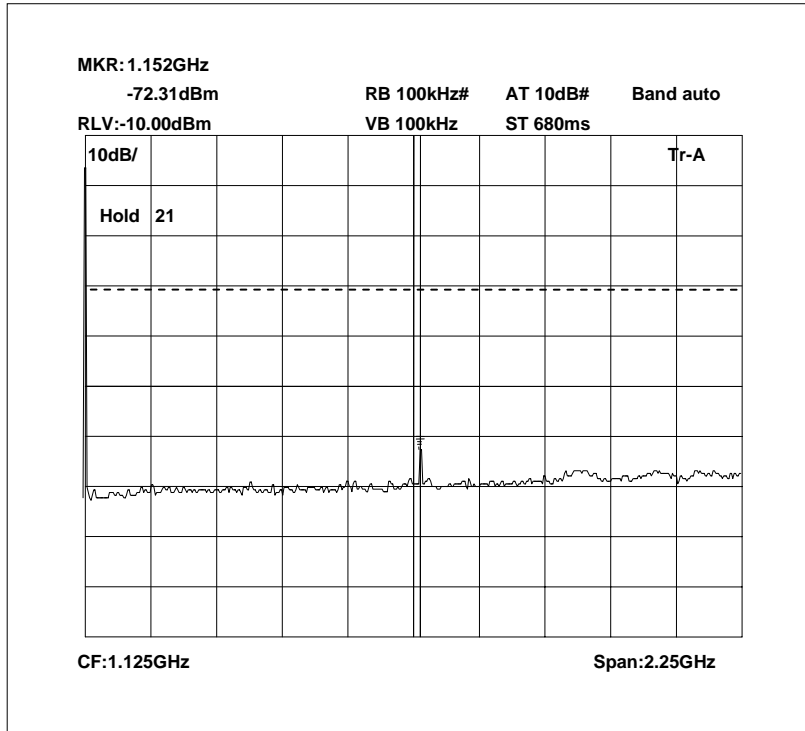

Radiated emissions 409.5 MHz 2.25 – 4.5GHz

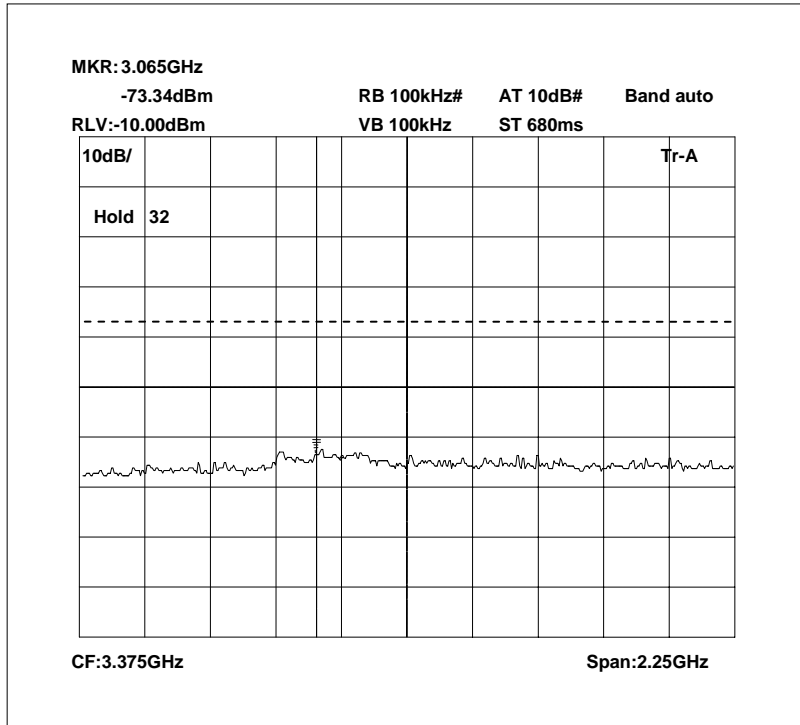

The above test results show that there were no emissions within 20dBs of the -13dBm limit.

Radiated emissions 411.0 MHz 0 – 2.25GHz

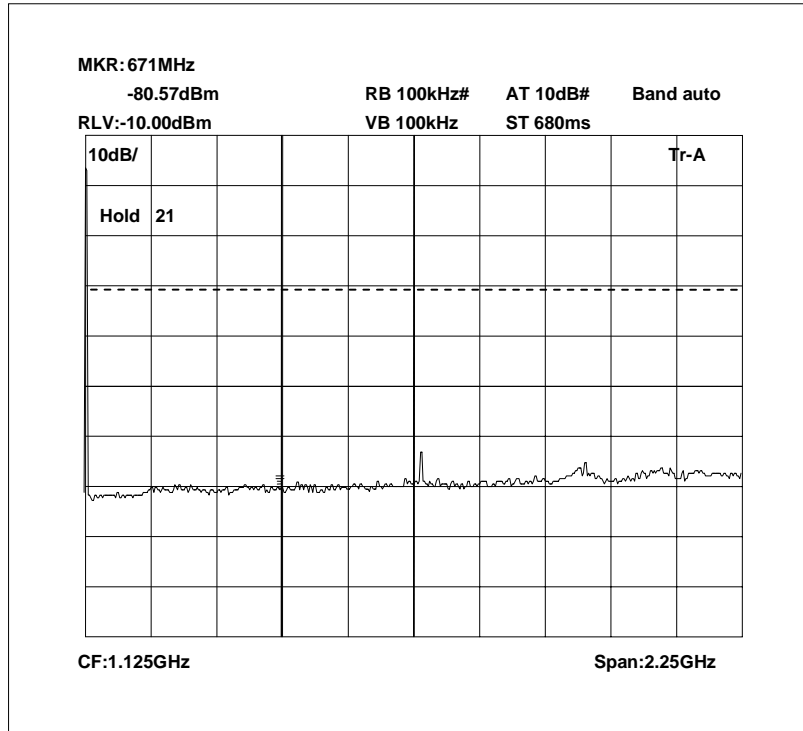

Radiated emissions 411.0 MHz 2.25 – 4.5GHz

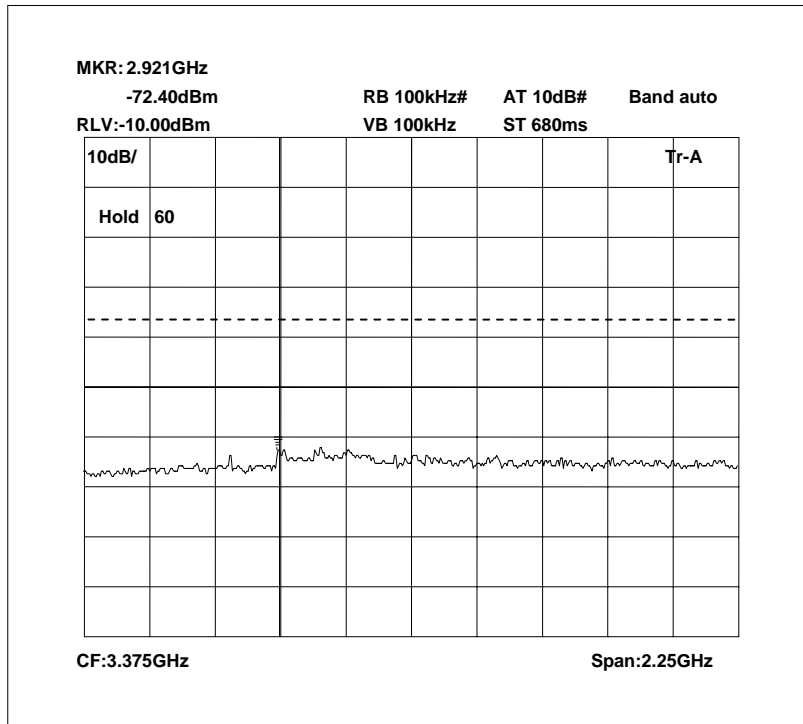

The above test results show that there were no emissions within 20dBs of the -13dBm limit.

Radiated emissions no input signal 0 – 2.25GHz

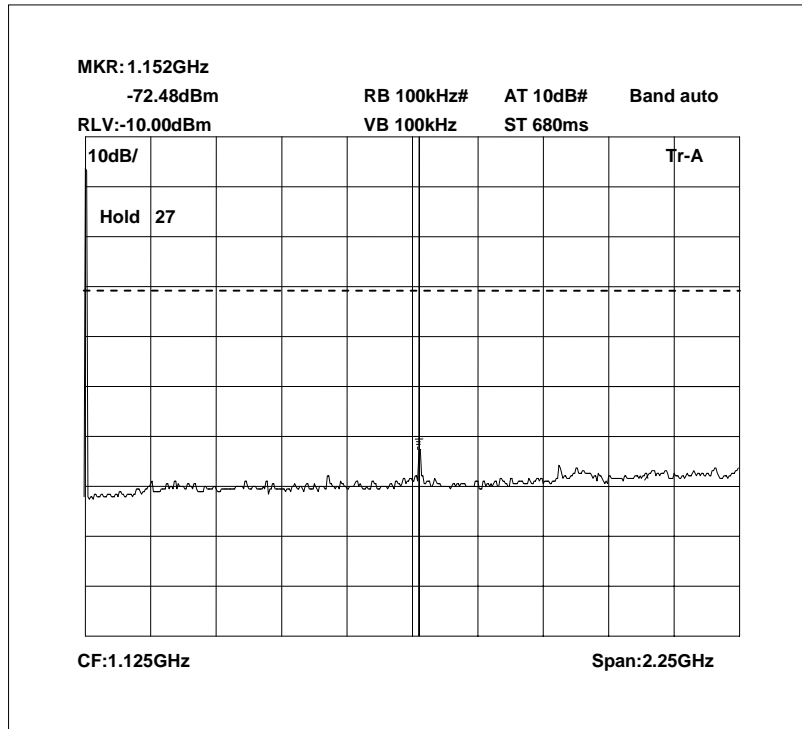

Radiated emissions no input signal 2.25 – 4.5GHz

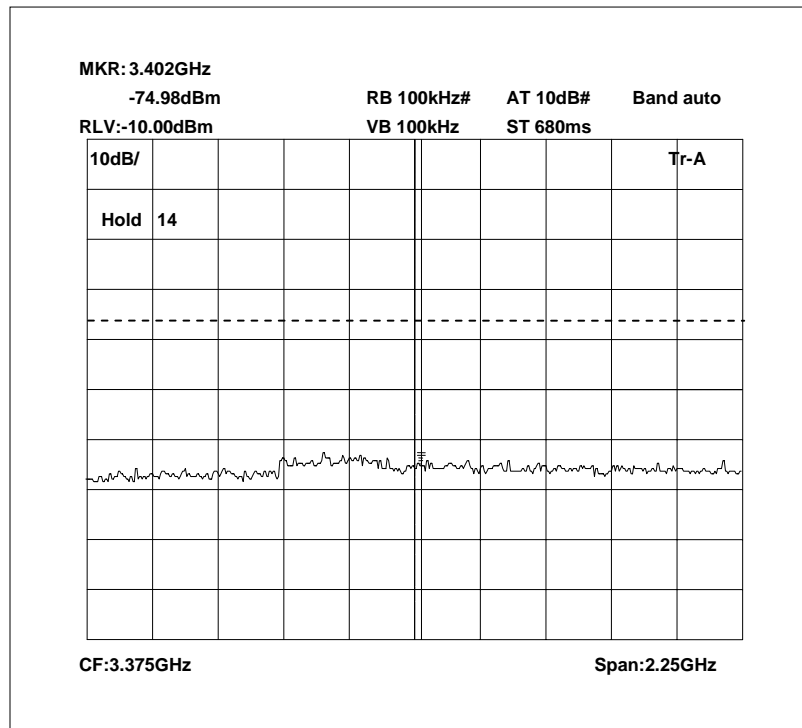

The above test results show that there were no emissions within 20dBs of the -13dBm limit.

ANNEX A
PHOTOGRAPHS

PHOTOGRAPH No. 1

TEST SETUP



PHOTOGRAPH No. 2

TEST SETUP



ANNEX B
APPLICANT'S SUBMISSION OF DOCUMENTATION LIST

APPLICANT'S SUBMISSION OF DOCUMENTATION LIST

a.	TCB	-	APPLICATION	[X]
		-	FEE	[X]
b.	AGENT'S LETTER OF AUTHORISATION	-		[X]
c.	MODEL(s) vs IDENTITY	-		[]
d.	ALTERNATIVE TRADE NAME DECLARATION(s)	-		[]
e.	LABELLING	-	PHOTOGRAPHS	[]
		-	DECLARATION	[]
		-	DRAWINGS	[]
f.	TECHNICAL DESCRIPTION	-		[X]
g.	BLOCK DIAGRAMS	-	Tx	[X]
		-	Rx	[]
		-	PSU	[]
		-	AUX	[]
h.	CIRCUIT DIAGRAMS	-	Tx	[]
		-	Rx	[]
		-	PSU	[]
		-	AUX	[]
i.	COMPONENT LOCATION	-	Tx	[]
		-	Rx	[]
		-	PSU	[]
		-	AUX	[]
j.	PCB TRACK LAYOUT	-	Tx	[]
		-	Rx	[]
		-	PSU	[]
		-	AUX	[]
k.	BILL OF MATERIALS	-	Tx	[]
		-	Rx	[]
		-	PSU	[]
		-	AUX	[]
l.	USER INSTALLATION / OPERATING INSTRUCTIONS	-		[X]

ANNEX C
EQUIPMENT CALIBRATION

TRL Number	Equipment Type	Manufacturer	Last Cal Calibration	Calibration Period	Due For Calibration
UH006	3m Range ERP CAL	TRL	06/01/2006	12	06/01/2007
UH028	Log Periodic Ant	Schwarbeck	28/04/2005	24	28/04/2007
UH029	Bicone Antenna	Schwarbeck	27/04/2005	24	27/04/2007
UH041	Multimeter	AVOmeter	14/12/2004	12	14/12/2005
UH075	Signal Generator	Marconi	22/03/2005	12	22/03/2006
UH120	Spectrum Analyser	Marconi	15/03/2005	12	15/03/2006
UH122	Oscilloscope	Tektronix	07/06/2005	24	07/06/2007
UH132	Power meter	Marconi	15/12/2004	12	15/12/2005
UH162	ERP Cable Cal	TRL	06/01/2006	12	06/01/2007
UH179	Power Sensor	Marconi	14/12/2004	12	14/12/2005
UH225	Attenuator	Spinner		Calibrate in use	
UH228	Power Sensor	Marconi	15/12/2004	12	15/12/2005
UH253	1m Cable N type	TRL	05/01/2006	12	05/01/2007
UH254	1m Cable N type	TRL	05/01/2006	12	05/01/2007
UH265	Notch filer	Telonic	24/06/2005	12	24/06/2006
L005	CMTA	R&S	05/12/2005	12	05/12/2006
L007	Loop Antenna	R&S	29/03/2005	24	29/03/2007
L103	Attenuator	Bird		Calibrate in use	
L138	1-18GHz Horn	EMCO	15/04/2005	24	15/04/2007
L139	1-18GHz Horn	EMCO	03/05/2005	24	03/05/2007
L176	Signal Generator	Marconi	31/01/2005	12	31/01/2006
L193	Bicone Antenna	Chase	12/10/2003	24	12/10/2005
L203	Log Periodic Ant	Chase	21/10/2003	24	21/10/2005
L280	18GHz Cable	Rosenberger	05/01/2006	12	05/01/2007
L343	CCIR Noise Filter	TRL	07/06/2005	12	07/06/2006
L426	Temperature Indicator	Fluke	14/12/2004	12	14/12/2005
L479	Analyser	Anritsu	18/11/2005	12	18/11/2006
L552	Signal Generator	Agilent	25/04/2005	12	25/04/2006

ANNEX D
MEASUREMENT UNCERTAINTY

Radio Testing – General Uncertainty Schedule

All statements of uncertainty are expanded standard uncertainty using a coverage factor of 1.96 to give a 95% confidence where no required test level exists.

[1] Adjacent Channel Power

Uncertainty in test result = **1.86dB**

[2] Carrier Power

Uncertainty in test result (Equipment - TRLUH120) = **2.18dB**

Uncertainty in test result (Equipment – TRL05) = **1.08dB**

Uncertainty in test result (Equipment – TRL479) = **2.48dB**

[3] Effective Radiated Power

Uncertainty in test result = **4.71dB**

[4] Spurious Emissions

Uncertainty in test result = **4.75dB**

[5] Maximum frequency error

Uncertainty in test result (Equipment - TRLUH120) = **119ppm**

Uncertainty in test result (Equipment – TRL05) = **0.113ppm**

Uncertainty in test result (Equipment – TRL479) = **0.265ppm**

[6] Radiated Emissions, field strength OATS 14kHz-18GHz Electric Field

Uncertainty in test result (14kHz – 30MHz) = **4.8dB**, Uncertainty in test result (30MHz – 1GHz) = **4.6dB**, Uncertainty in test result (1GHz-18GHz) = **4.7dB**

[7] Frequency deviation

Uncertainty in test result = **3.2%**

[8] Magnetic Field Emissions

Uncertainty in test result = **2.3dB**

[9] Conducted Spurious

Uncertainty in test result (Equipment TRL479) Up to 8.1GHz = **3.31dB**

Uncertainty in test result (Equipment TRL479) 8.1GHz – 15.3GHz = **4.43dB**

Uncertainty in test result (Equipment TRL479) 15.3GHz – 21GHz = **5.34dB**

Uncertainty in test result (Equipment TRLUH120) Up to 26GHz = **3.14dB**

[10] Channel Bandwidth

Uncertainty in test result = **15.5%**

[11] Amplitude and Time Measurement – Oscilloscope

Uncertainty in overall test level = **2.1dB**, Uncertainty in time measurement = **0.59%**, Uncertainty in Amplitude measurement = **0.82%**

[11] Power Line Conduction

Uncertainty in test result = **3.4dB**

ANNEX E
SYSTEM DIAGRAM

