



**A RADIO TEST REPORT**

**FOR**

**Axell Wireless Limited**

**ON**

**D-CSR 3302 Digital Channel Selective Repeater  
D-CSR-3302-8-140-170-DP-AC**

**DOCUMENT NO. TRA-017758-04-47-00-A**

**HULL**

Unit E, South Orbital Trading Park, Hedon Road, Hull, HU9 1NJ, UK.

**T** +44 (0)1482 801801 **F** +44 (0)1482 801806 **E** test@tracglobal.com

[www.tracglobal.com](http://www.tracglobal.com)

**TRaC Wireless Test Report** : TRA-017758-04-47-00-A

**Applicant** : Axell Wireless Limited

**Apparatus** : D-CSR-3302-8-140-170-DP-AC

**Specification(s)** : CFR47 Part 90, Part 20

**Purpose of Test** : **Certification**

**FCCID** : NEO51-201SERIES

**Certification Number** : 8749A-51201SERIES

**Authorised by** :

: Radio Product Manager

**Issue Date** : **6<sup>th</sup> November 2014**

**Authorised Copy Number** : *PDF*

---

**Contents**

Section 1:	Introduction	4
1.1	General	4
1.2	Tests Requested By	5
1.3	Manufacturer	5
1.4	Apparatus Assessed	5
1.5	Test Result Summary	6
1.6	Equipment Test Conditions	7
1.7	Standard References	8
1.8	Notes Relating To Assessment	9
1.9	Deviations from Test Standards	10
Section 2:	Measurement Uncertainty	11
2.1	Measurement Uncertainty Values	11
Section 3:	Modifications	13
3.1	Modifications Performed During Assessment	13
Appendix A:	Uplink Formal Emission Test Results	14
A1	RF Gain and Output Power	15
A2	Amplifier Intermodulation Spurious Emissions	16
A3	Amplifier Modulated Channel Test	19
A4	Spurious Emissions at Antenna Terminals Less than 1MHz	21
A5	Spurious Emissions at Antenna Terminals Greater than 1MHz	23
A6	Noise at Antenna Terminals	25
A7	Radiated Electric Field Emissions	29
A8	Passband Gain & Bandwidth	32
Appendix B:	Downlink Formal Emission Test Results	34
B1	RF Gain and Output Power	35
B2	Amplifier Intermodulation Spurious Emissions	36
B3	Amplifier Modulated Channel Test	41
B4	Spurious Emissions at Antenna Terminals Less than 1MHz	43
B5	Spurious Emissions at Antenna Terminals Greater than 1MHz	45
B6	Noise at Antenna Terminals	47
B7	Radiated Electric Field Emissions	51
B8	Passband Gain & Bandwidth	54
Appendix C:	Additional Test and Sample Details	56
Appendix D:	Additional Information	62
Appendix E:	Photographs and Figures	68

**Section 1:****Introduction****1.1 General**

This report contains an assessment of an apparatus against Electromagnetic Compatibility Standards based upon tests carried out on samples submitted to the Laboratory.

Test performed by: TRaC Global [ ]  
Unit E  
South Orbital Trading Park  
Hedon Road  
Hull, HU9 1NJ.  
United Kingdom.

Telephone: +44 (0) 1482 801801  
Fax: +44 (0) 1482 801806

TraC Global [X]  
Unit 1  
Pendle Place  
Skelmersdale  
West Lancashire, WN8 9PN  
United Kingdom

Telephone: +44 (0) 1695 556666  
Fax: +44 (0) 1695 577077

Email: [test@tracglobal.com](mailto:test@tracglobal.com)  
Web site: <http://www.tracglobal.com>

Tests performed by: S Hodgkinson

Report author: S Hodgkinson

**This report must not be reproduced except in full without prior written permission from TRaC Global.**

## 1.2 Tests Requested By

This testing in this report was requested by :

Aerial House  
Asheridge Road  
Chesham  
Buckinghamshire  
HP5 1TU

## 1.3 Manufacturer

Aerial House  
Asheridge Road  
Chesham  
Buckinghamshire  
HP5 1TU

## 1.4 Apparatus Assessed

The following apparatus was assessed between 26<sup>th</sup> September – 7<sup>th</sup> October 2014

D-CSR-3302-8-140-170-DP-AC

The D-CSR-3302 is a band settable/channel selective device.  
For the purposes of testing the device was setup to operate the following band.

Upper 5MHz Band only 168.4 MHz – 173.4 MHz

There are up to 8 selectable channels available in each 5MHz band.  
The channels were selected dependent upon each test requirement.

Please note that the unit was only tested in the top 5MHz operating Band. The device was tested in the top 5MHz band only, as the lower frequency bands are already covered under the original TRaC radio test report TRA-017758-00-47-00-D. The device will be restricted to operation within the correct frequency ranges on a location by location basis. Testing performed below 150MHz is not applicable for FCC requirements; the testing covers the new higher extended frequency range.

## 1.5 Test Result Summary

Full details of test results are contained within Appendix A. The following table summarises the results of the assessment.

The statements relating to compliance with the standards below apply ONLY as qualified in the notes and deviations stated in sections 1.6 to 1.7 of this test report.

Full details of test results are contained within Appendix A. The following table summarises the results of the assessment.

Test Type	FCC Part	Appendix in Report	Result
RF Gain and Power Output	90.219(e)(1)	A1 & B1	Pass
Intermodulation Spurious Emissions	90.219(e)(3)	A2 & B2	Pass
Occupied Bandwidth & Modulation	90.219(a) 90.219(4)(e)(ii) 90.210(d)	A3 & B3	Pass
Spurious Emissions at Antenna Terminals Less than 1MHz	90.219(e)(3) 90.210(d)	A4 & B4	Pass
Spurious Emissions at Antenna Terminals Greater than 1MHz	90.219(e)(3)	A5 & B5	Pass
Noise At Antenna Terminals	90.219(e)(2)	A6 & B6	Pass
Field Strength of Spurious Emissions	90.219(e)(3)	A7 & B7	Pass
Passband Gain & 20dB bandwidth	N/A	A8 & B8	Pass
Frequency Stability	90.213	N/A(note 1)	N/A
Transient behaviour	90.214	N/A(note 2)	N/A
Audio Frequency Response (a)	TIA EIA-603.3.2.6	N/A	N/A
Modulation Limiting	TIA EIA-603.3.2.6	N/A	N/A

Notes:

1 The EUT does not contain modulation circuitry, therefore the test was not performed.

2 The EUT is not a keyed carrier system, therefore the test was not performed.

Abbreviations used in the above table:

CFR : Code of Federal Regulations  
REFE : Radiated Electric Field Emissions  
A Uplink Results Appendix

ANSI : American National Standards Institution  
PLCE : Power Line Conducted Emissions  
B Downlink Results Appendix

## 1.6 Equipment Test Conditions

Product class:	Uplink	Class A <input checked="" type="checkbox"/> Class B <input type="checkbox"/>
	Downlink	Class A <input checked="" type="checkbox"/> Class B <input type="checkbox"/>
Product Use:	Private Land Mobile Repeater	
Supply Voltages:	Vnom	110Vac
Note: Vnom voltages are as stated above unless otherwise shown on the test report page		
Equipment Category:	Single channel	<input type="checkbox"/>
	Two channel	<input type="checkbox"/>
	Multi-channel	<input checked="" type="checkbox"/>
Test Location	TRaC Global	
	Skelmersdale	<input checked="" type="checkbox"/>
	Hull	<input type="checkbox"/>
	Other	<input type="checkbox"/> Please Specify

## 1.7 Standard References

47 CFR 2	Code of Federal Regulations, Title 47, Part 2, "Frequency allocations and Radio Telemetry Matters; General Rules and Regulations"
47 CFR 90	Code of Federal Regulations, Title 47, Part 90, "Land Mobile Radio Service"
47 CFR 15	Code of Federal Regulations, Title 47, Part 15, "Radio Frequency Devices" Subpart B, "Unintentional Radiators"
C63.4-2003	American National Standards Institute (ANSI), "Methods of Measurement of Radio Noise Emissions from Low Voltage Electrical and Electronic Equipment in the Range 9 kHz to 40 GHz"
TIA EIA-603-D	Land Mobile FM or PM Communications Equipment Measurement and Performance Standards



## 1.8 Notes Relating To Assessment

With regard to this assessment, the following points should be noted:

The results contained in this report relate only to the items tested and were obtained in the period between the date of initial receipt of samples and the date of issue of the report.

The apparatus was set up and exercised using the configurations, modes of operation and arrangements defined in this report only.

Particular operating modes, apparatus monitoring methods and performance criteria required by the standards tested to have been performed except where modified in Section 1.7 of this test report (Deviations from Test Standards).

For emissions testing, throughout this test report, "Pass" indicates that the results for the sample as tested were below the specified limit (refer also to Section 2, Measurement Uncertainty).

Where relevant, the apparatus was only assessed using the monitoring methods and susceptibility criteria defined in this report.

All testing with the exception of testing at the Open Area Test Site was performed under the following environmental conditions:

Temperature	: 17 to 23 °C
Humidity	: 45 to 75 %
Barometric Pressure	: 86 to 106 kPa

All dates used in this report are in the format dd/mm/yy.

This assessment has been performed in accordance with the requirements of ISO/IEC 17025.

## **1.9 Deviations from Test Standards**

There were no deviations from the standards tested to.

**Section 2:****Measurement Uncertainty****2.1 Measurement Uncertainty Values**

For the test data recorded the following measurement uncertainty was calculated:

**Radio Testing – General Uncertainty Schedule**

*All statements of uncertainty are expanded standard uncertainty using a coverage factor of 1.96 to give a 95% confidence where no required test level exists.*

**[1] Adjacent Channel Power**

Uncertainty in test result = **1.86dB**

**[2] Carrier Power**

Uncertainty in test result (Power Meter) = **1.08dB**

Uncertainty in test result (Spectrum Analyser) = **2.48dB**

**[3] Effective Radiated Power**

Uncertainty in test result = **4.71dB**

**[4] Spurious Emissions**

Uncertainty in test result = **4.75dB**

**[5] Maximum frequency error**

Uncertainty in test result (Frequency Counter) = **0.113ppm**

Uncertainty in test result (Spectrum Analyser) = **0.265ppm**

**[6] Radiated Emissions, field strength OATS 14kHz-18GHz Electric Field**

Uncertainty in test result (14kHz – 30MHz) = **4.8dB**,

Uncertainty in test result (30MHz – 1GHz) = **4.6dB**,

Uncertainty in test result (1GHz – 18GHz) = **4.7dB**

**[7] Frequency deviation**

Uncertainty in test result = **3.2%**

**[8] Magnetic Field Emissions**

Uncertainty in test result = **2.3dB**

**[9] Conducted Spurious**

Uncertainty in test result – Up to 8.1GHz = **3.31dB**

Uncertainty in test result – 8.1GHz – 15.3GHz = **4.43dB**

Uncertainty in test result – 15.3GHz – 21GHz = **5.34dB**

Uncertainty in test result – Up to 26GHz = **3.14dB**

**[10] Channel Bandwidth**

Uncertainty in test result = **15.5%**

**[11] Amplitude and Time Measurement – Oscilloscope**

Uncertainty in overall test level = **2.1dB**,  
Uncertainty in time measurement = **0.59%**,  
Uncertainty in Amplitude measurement = **0.82%**

**[12] Power Line Conduction**

Uncertainty in test result = **3.4dB**

**[13] Spectrum Mask Measurements**

Uncertainty in test result = **2.59% (frequency)**  
Uncertainty in test result = **1.32dB (amplitude)**

**[14] Adjacent Sub Band Selectivity**

Uncertainty in test result = **1.24dB**

**[15] Receiver Blocking – Listen Mode, Radiated**

Uncertainty in test result = **3.42dB**

**[16] Receiver Blocking – Talk Mode, Radiated**

Uncertainty in test result = **3.36dB**

**[17] Receiver Blocking – Talk Mode, Conducted**

Uncertainty in test result = **1.24dB**

**[18] Receiver Threshold**

Uncertainty in test result = **3.23dB**

**[19] Transmission Time Measurement**

Uncertainty in test result = **7.98%**

**Section 3:**

**Modifications**

**3.1 Modifications Performed During Assessment**

No modifications were performed during the assessment

**Appendix A:****Uplink Formal Emission Test Results**

Abbreviations used in the tables in this appendix:

Spec	: Specification	ALSR	: Absorber Lined Screened Room
Mod	: Modification	OATS	: Open Area Test Site
EUT	: Equipment Under Test	ATS	: Alternative Test Site
SE	: Support Equipment	Ref	: Reference
L	: Live Power Line	Freq	: Frequency
N	: Neutral Power Line	MD	: Measurement Distance
E	: Earth Power Line	SD	: Spec Distance
Pk	: Peak Detector	Pol	: Polarisation
QP	: Quasi-Peak Detector	H	: Horizontal Polarisation
Av	: Average Detector	V	: Vertical Polarisation
CDN	: Coupling & decoupling network		

**A1 RF Gain and Output Power**

<b>Test Details:</b>	
Measurement standard	Part 2.1046, Part 90.219(e)(1)
EUT sample number	S01
Modification state	0
SE in test environment	None
SE isolated from EUT	None
EUT set up	Refer to Appendix C

Frequency MHz	Signal Generator input level dBm	Input Cable Loss dB	Level at Spectrum Analyser dBm	Output Cable & Attenuator loss dB	Gain dB	Conducted Output Power dBm	Gain after 10dB input level increase dB
173.3875	-54.68	0.15	-14.02	40.50	81.31	26.48	70.11

Notes: 1. The signal generator input was increased by 10dBs and the level of the output signal remeasured.

As per Annex .3 Policies + Procedures (k) of KDB 935210 D02 Signal Boosters Certification v02 the EUT was tested at compression and 10dB into compression to show AGC operation

Please note that the unit was only tested in the top 5MHz operating Band. The device was tested in the top 5MHz band only, as the lower frequency bands are already covered under TRaC radio test report TRA-017758-00-47-00-D.

**A2 Amplifier Intermodulation Spurious Emissions**

Test Details:	
Measurement standard	Part 2.1053, 90.219(e)(3)
EUT sample number	S01
Modification state	0
SE in test environment	None
SE isolated from EUT	None
EUT set up	Refer to Appendix C

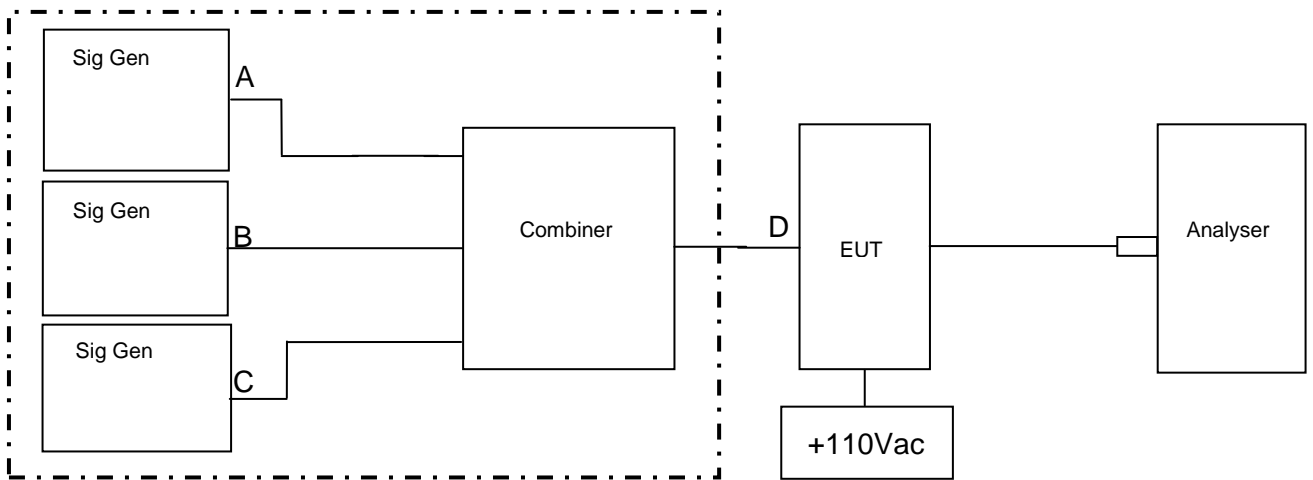

Signal Generator B was varied in frequency to check if intermodulation products were produced.

RF Input Frequency (MHz)			Highest Intermodulation Product Level (dBm)	Limit (dBm)
Upper 5 MHz Band				
168.4125	171.7300	173.3875	-21.32dBm @ 170.058653	-13

Sweep data is shown on the next page:

Please note that the unit was only tested in the top 5MHz operating Band. The device was tested in the top 5MHz band only, as the lower frequency bands are already covered under TRaC radio test report TRA-017758-00-47-00-D.

**Results**

The EUT was found to comply with the limits

See plots below

As per Annex .3 Policies + Procedures (k) of KDB 935210 D02 Signal Boosters Certification v02 the EUT was tested at compression and 10dB into compression to show AGC operation, worst case results taken.



Upper 5 MHz band - Intermodulation close View

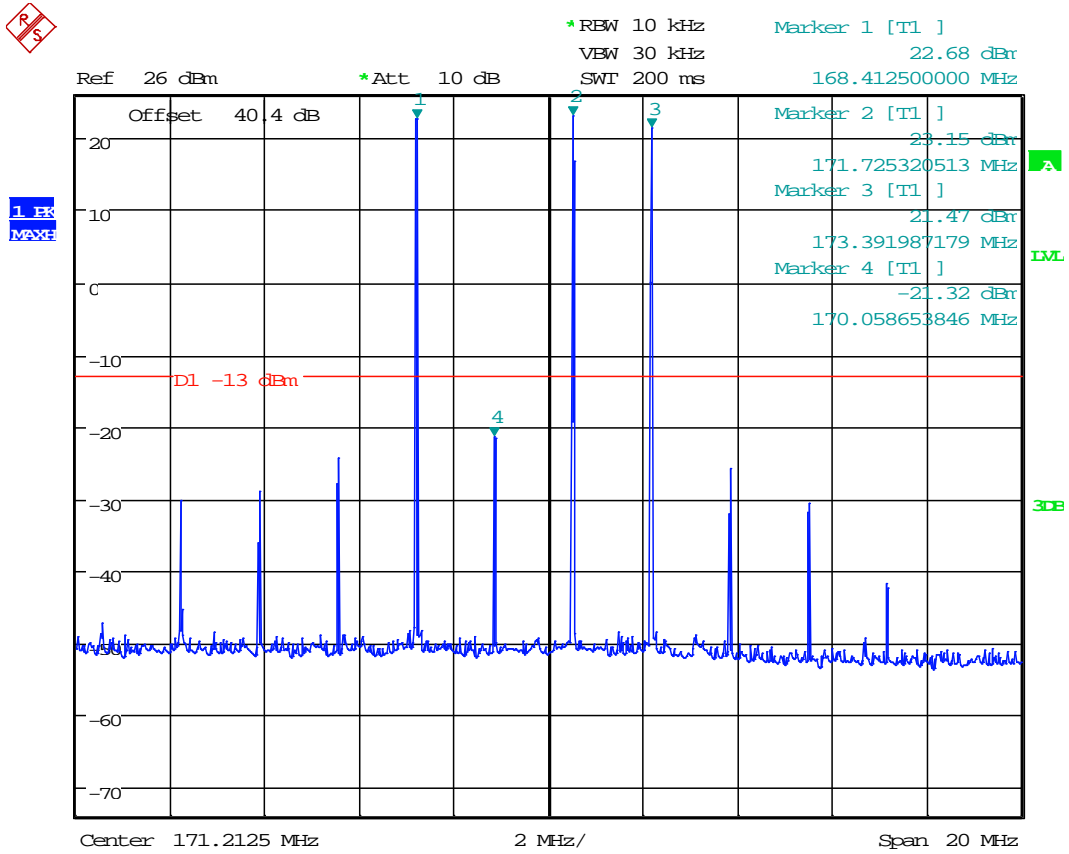

Date: 6.OCT.2014 15:48:56

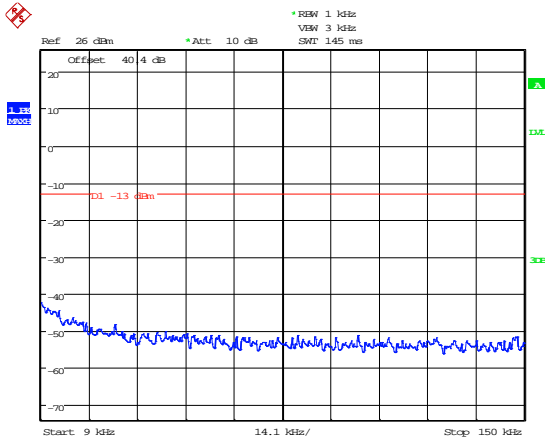

Date: 6.OCT.2014 15:49:57

9-150kHz

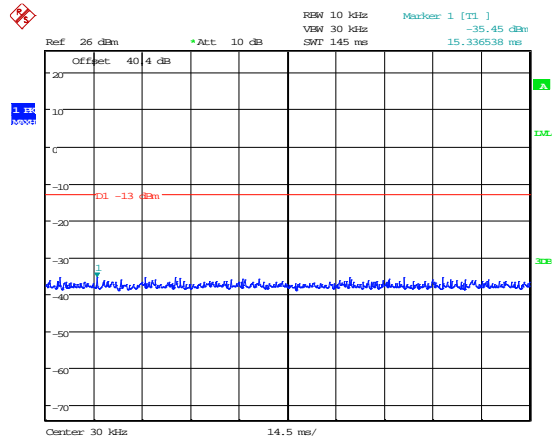

Date: 6.OCT.2014 15:50:32

150kHz – 30MHz

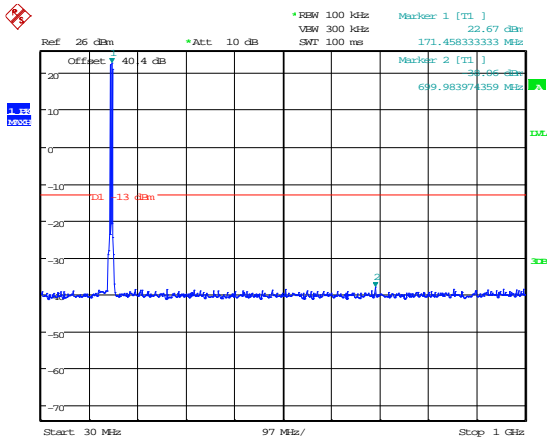

Date: 6.OCT.2014 15:51:38

30MHz – 1GHz

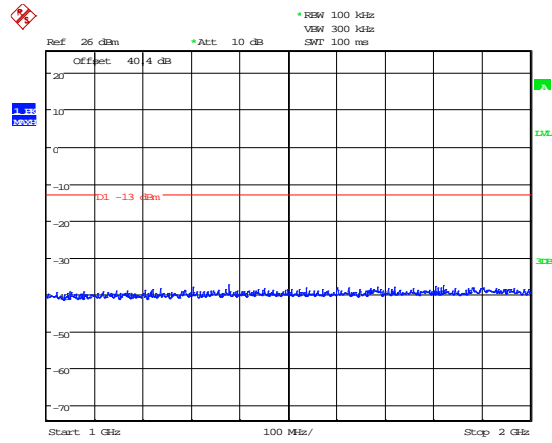

Date: 6.OCT.2014 15:52:05

1GHz – 2GHz

**A3 Amplifier Modulated Channel Test**

<b>Test Details:</b>	
Measurement standard	Part 2.1049, Part 90.219(e)(4)(ii), 90.210(d)
EUT sample number	S01
Modification state	0
SE in test environment	None
SE isolated from EUT	None
EUT set up	Refer to Appendix C

Modulation Type	Frequency Of Operation Channel (MHz)
Analogue	10.096kHz

As per Annex .3 Policies + Procedures (k) of KDB 935210 D02 Signal Boosters Certification v02 the EUT was tested at compression and 10dB into compression to show AGC operation, worst case results taken.

Please note that the unit was only tested in the top 5MHz operating Band. The device was tested in the top 5MHz band only, as the lower frequency bands are already covered under TRaC radio test report TRA-017758-00-47-00-D.

173.3875 Analogue Signal Generator and EUT

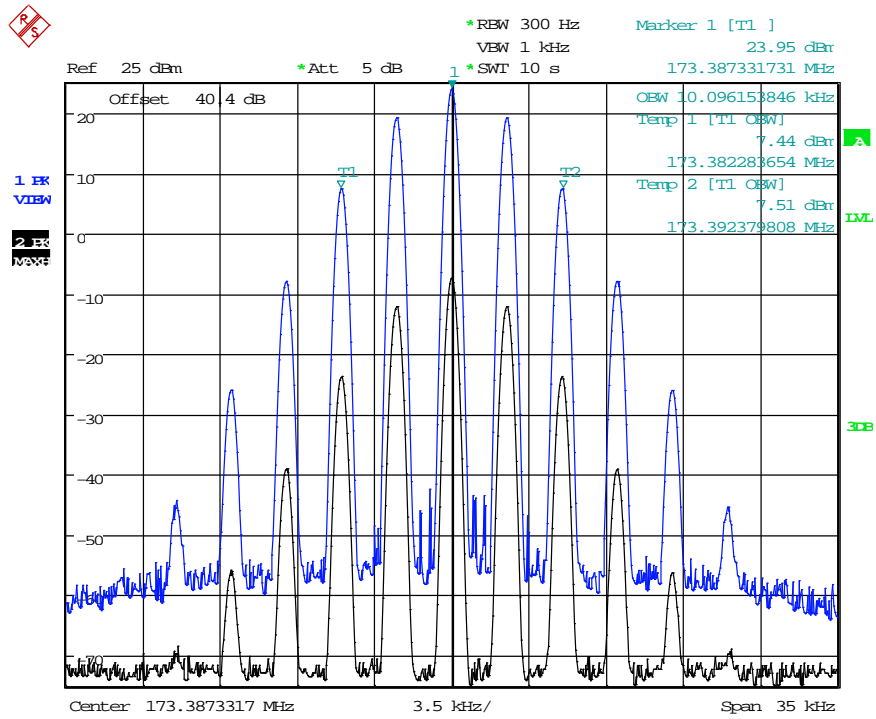

Date: 30.SEP.2014 15:22:21

The above plots depicting the output waveshape show no measurable distortion visible when compared to the input signal.

**A4 Spurious Emissions at Antenna Terminals Less than 1MHz**

<b>Test Details:</b>	
Measurement standard	Part 2.1053, 90.219(e)(3), 90.210(d)
EUT sample number	S01
Modification state	0
SE in test environment	None
SE isolated from EUT	None
EUT set up	Refer to Appendix C

Modulation Type	Bandedge	Carrier Frequency (MHz)	Max Level @ bandedge (dBm)
Analogue	Upper	173.3875	-56.80

Please note that the unit was only tested in the top 5MHz operating Band. The device was tested in the top 5MHz band only, as the lower frequency bands are already covered under TRaC radio test report TRA-017758-00-47-00-D.



**A5 Spurious Emissions at Antenna Terminals Greater than 1MHz**

Test Details:	
Measurement standard	Part 2.1053, 90.219(e)(3)
EUT sample number	S01
Modification state	0
SE in test environment	None
SE isolated from EUT	None
EUT set up	Refer to Appendix C

Please note that the unit was only tested in the top 5MHz operating Band. The device was tested in the top 5MHz band only, as the lower frequency bands are already covered under TRaC radio test report TRA-017758-00-47-00-D.

**Top channel**

Frequency Range (MHz)	Freq. of Emission (MHz)	Measured Level (dBm)	Attenuator & Cable Losses (dB)	Spurious Emission Level (dBm)	Limit dBm
9kHz - 2GHz	No Significant Emissions Within 20 dB of the Limit				-13

Limit is determined by the outermost step of the emissions mask and is calculated as follows:

At least  $43 + 10 \log P$  dB

$$(10\log P_{\text{watts}}) - (43 + 10\log (P_{\text{watts}} * 1000)) = \text{LIMIT} = -13 \text{ dBm}$$

**Result**

The EUT was found to comply with the limits

Spurious Emissions at Antenna Terminals Greater than 1MHz 173.3875MHz

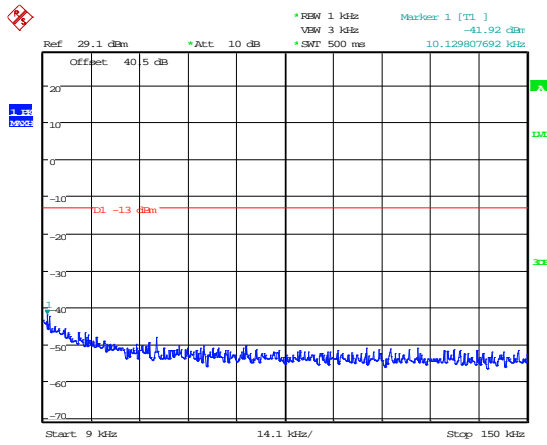

Date: 6.OCT.2014 11:28:29

9-150kHz

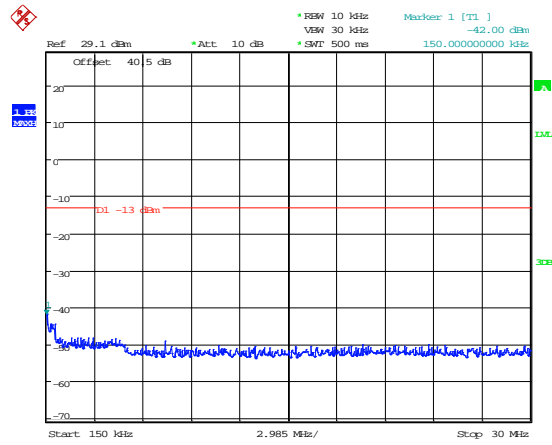

Date: 6.OCT.2014 11:28:58

150kHz – 30MHz

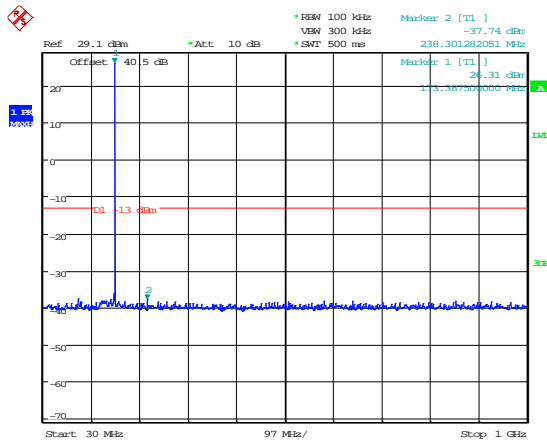

Date: 6.OCT.2014 11:27:36

30MHz – 1GHz

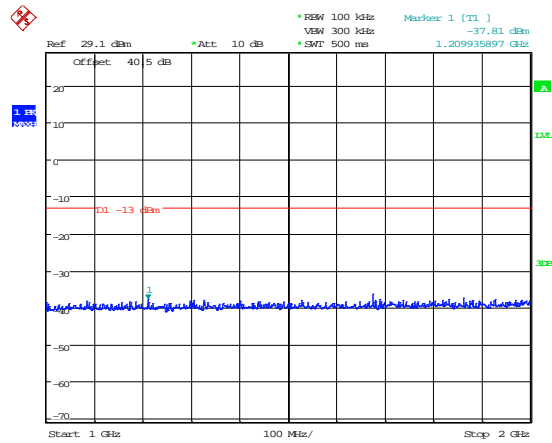

Date: 6.OCT.2014 11:27:59

1GHz – 2GHz



**A6 Noise at Antenna Terminals**

<b>Test Details:</b>	
Measurement standard	90.219(e)(2), 90.219(e)(3)
EUT sample number	S01
Modification state	0
SE in test environment	None
SE isolated from EUT	None
EUT set up	Refer to Appendix C

Compliance with these levels will be deemed satisfaction of the good engineering practice requirement. In a 10 kHz measurement bandwidth:

- (1) the ERP of noise within the signal booster passband should not exceed  $-43\text{dBm}$ ;  
and
- (2) the ERP of noise on spectrum more than 1 MHz outside of the signal booster passband should not exceed  $-70\text{ dBm}$ .
- (3) The noise figure of a signal booster must not exceed 9 dB in either direction

See appendix D for manufactures declaration on good engineering practice.

IN BAND AMPLIFIER NOISE – Upper 5 MHz Band

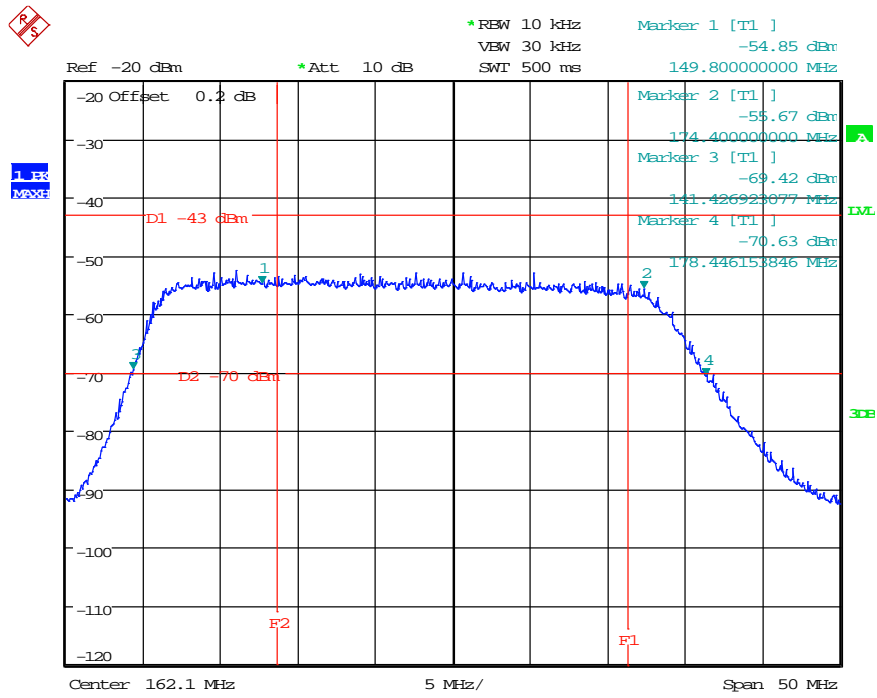

Date: 6.OCT.2014 12:12:21

## Signal booster noise figure

Test equipment set up:-

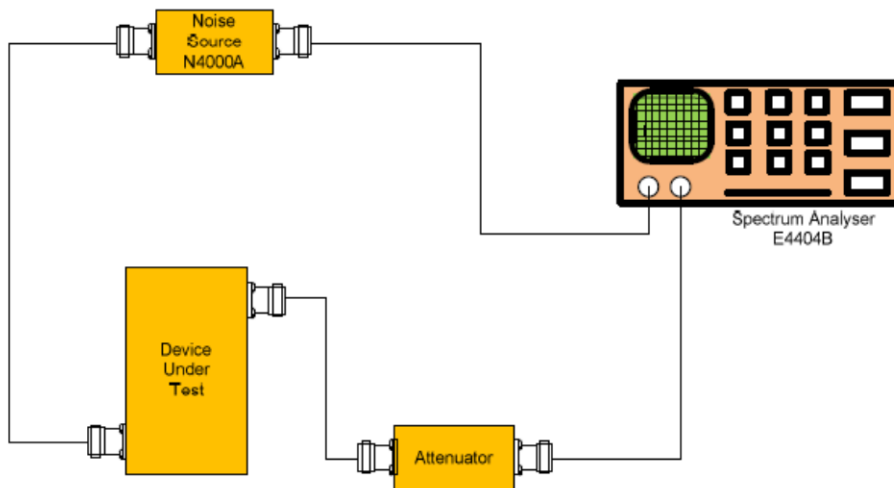

## Result

Plots for noise figure, taken with the 18MHz filter applied at maximum gain with 70dB external attenuators in the test set up

Frequency (MHz)	Noise Figure dB
173.3875	6.97

General notes about measurement setup:

- 1) The spectrum analyser has the noise figure measurement personality enabled.

Please note that the unit was only tested in the top 5MHz operating Band. The device was tested in the top 5MHz band only, as the lower frequency bands are already covered under TRaC radio test report TRA-017758-00-47-00-D.

Noise Figure – 173.9875 MHz

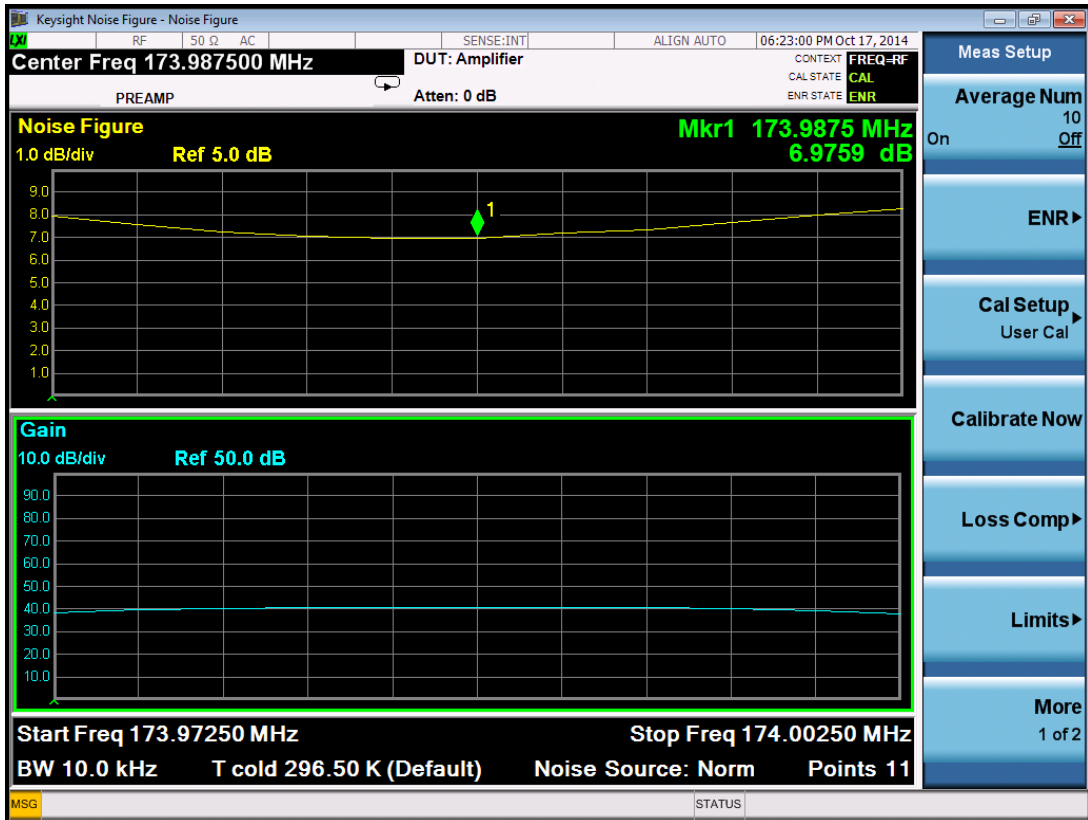

**A7 Radiated Electric Field Emissions**

Preliminary scans were performed using a peak detector with the RBW = 100kHz. The radiated electric field emission test applies to all spurious and harmonic emissions. The EUT was set to transmit as required.

The following test site was used for final measurements as specified by the standard tested to:

3m open area test site :                       3m alternative test site :

The effect of the EUT set-up on the measurements is summarised in note (c) below.

<b>Test Details:</b>	
Measurement standard	Title 47 of the CFR: Part90.219(e)(3) RSS-131 Section 4.4
Frequency range	30 MHz – 2 GHz
EUT sample number	S01
Modification state	0
SE in test environment	None
SE isolated from EUT	None
EUT set up	Refer to Appendix C

Please note that the unit was only tested in the top 5MHz operating Band. The device was tested in the top 5MHz band only, as the lower frequency bands are already covered under TRaC radio test report TRA-017758-00-47-00-D.

**Top Frequency**

FREQUENCY RANGE	FREQ. (MHz)	ERP/EIRP (dBm)	LIMIT (dBm)
30MHz - 2GHz	No Significant Emissions Within 20 dB of the Limit		-13

**Result**

The EUT was found to comply with the limits

**Notes:**

1. Emissions Checked up to 10 times Fc.
2. The unit was mounted on a turntable and rotated through 360° and in 3 orthogonal planes to find the worst case emission.
3. For Frequencies below 1 GHz, RBW = 120 kHz, testing was performed with CISPR16 compliant test receiver with QP detector. Above 1 GHz tests were performed using a spectrum analyser using the following settings:

Peak Detector                  RBW = 1MHz; VBW = ≥RBW

4. Limit is determined as the outermost step of the emissions mask and is calculated as follows.

At least 43 + 10 log P dB

$$(10\log P_{\text{watts}}) - (43 + 10\log (P_{\text{watts}} * 1000)) = \text{LIMIT} = -13 \text{ dBm}$$

The upper and lower frequency of the measurement range was decided according to 47 CFR Part 2.1057.

- (a) Where results have been measured at one distance, and a signal level displayed at another, the results have been extrapolated using the following formula:

$$\text{Extrapolation (dB)} = 20 \log_{10} \left( \frac{\text{measurement distance}}{\text{specification distance}} \right)$$

- (b) The levels may have been rounded for display purposes.
- (c) The following table summarises the effect of the EUT operating mode, internal configuration and arrangement of cables / samples on the measured emission levels :

	See (i)	See (ii)	See (iii)	See (iv)
Effect of EUT operating mode on emission levels	✓			
Effect of EUT internal configuration on emission levels	✓			
Effect of Position of EUT cables & samples on emission levels	✓			
(i)      Parameter defined by standard and / or single possible, refer to Appendix D (ii)     Parameter defined by client and / or single possible, refer to Appendix D (iii)    Parameter had a negligible effect on emission levels, refer to Appendix D (iv)    Worst case determined by initial measurement, refer to Appendix D				

Radiated Electric Field Emissions 173.3875MHz

30MHz – 1GHz

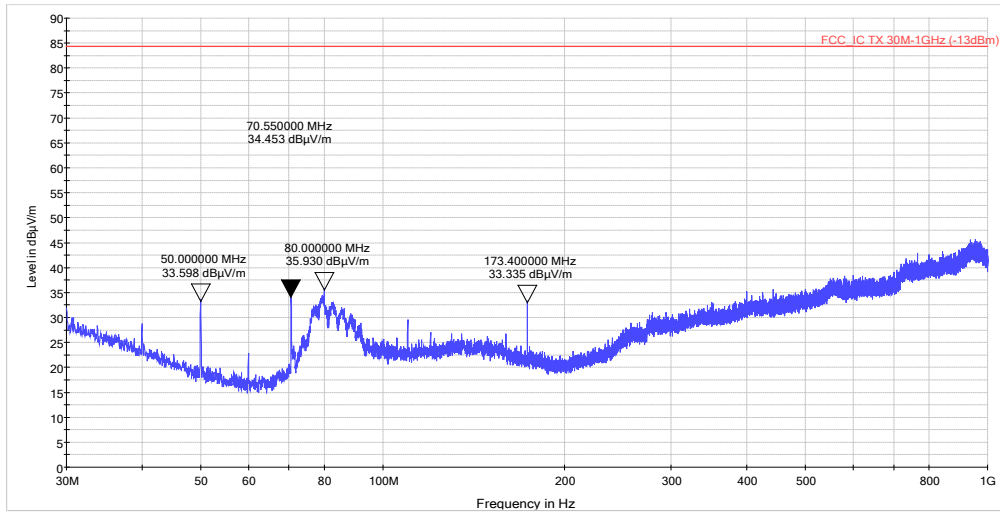

1GHz – 2GHz

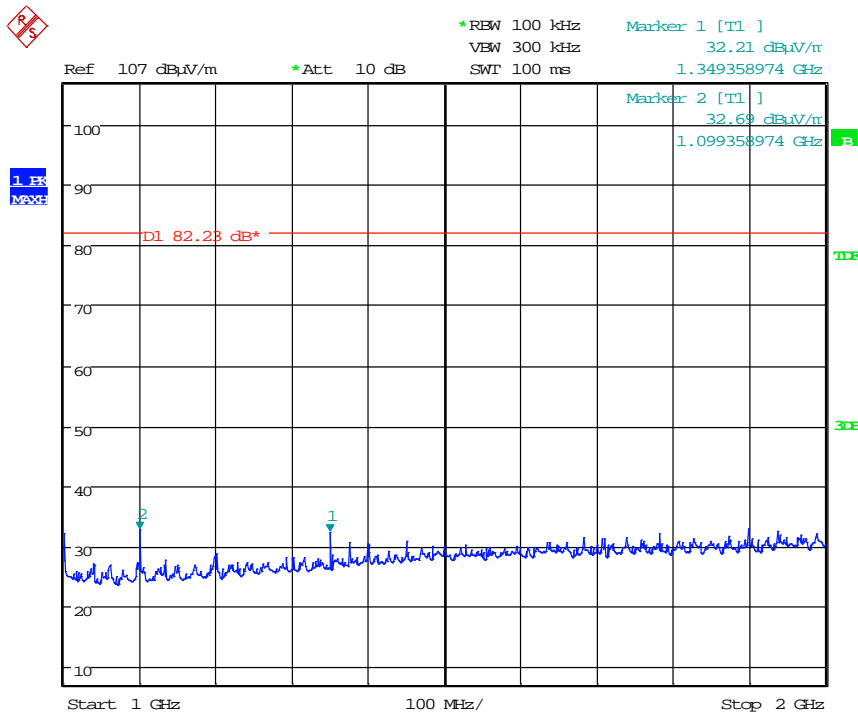

Date: 7.OCT.2014 14:43:24

**A8 Passband Gain & Bandwidth**

<b>Test Details:</b>	
Measurement standard	RSS-131 Section 4.2
	D.3 Policies + Procedures (k) of KDB 935210 D02 Signal Boosters Certification v02
EUT sample number	S01
Modification state	0
SE in test environment	None
SE isolated from EUT	None
EUT set up	Refer to Appendix C

Frequency MHz	F <sub>l</sub> MHz	F <sub>h</sub> MHz	20 dB Bandwidth
173.3875	173.357051	173.417948	60.89kHz

1. See below for plots showing passband gain & bandwidth

With the aid of a CW Swept signal generator and spectrum analyser, the bandwidth and frequency response of the open channel (i.e. at the point where the gain has fallen by 20 dB) is measured. This measurement shows the gain-versus-frequency response of the open channel from the midband frequency  $f_0$  of the channel up to at least  $f_0 + 250\%$  of the 20 dB bandwidth.

Please note that the unit was only tested in the top 5MHz operating Band. The device was tested in the top 5MHz band only, as the lower frequency bands are already covered under TRaC radio test report TRA-017758-00-47-00-D.



Upper 5 MHz band – 173.3875 MHz

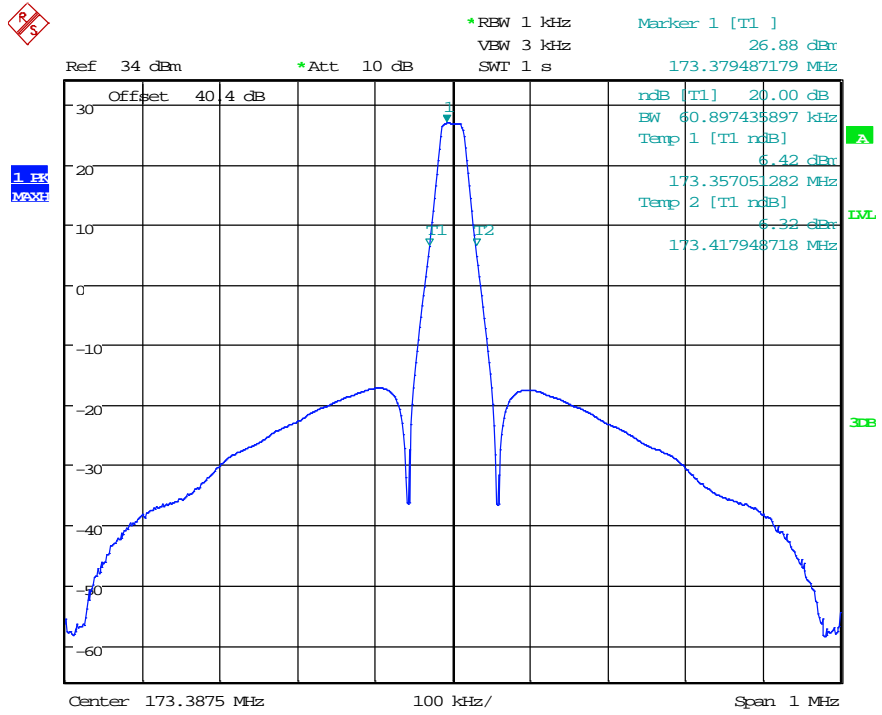

Date: 6.OCT.2014 15:08:41

**Appendix B:****Downlink Formal Emission Test Results**

Abbreviations used in the tables in this appendix:

Spec	: Specification	ALSR	: Absorber Lined Screened Room
Mod	: Modification	OATS	: Open Area Test Site
EUT	: Equipment Under Test	ATS	: Alternative Test Site
SE	: Support Equipment	Ref	: Reference
L	: Live Power Line	Freq	: Frequency
N	: Neutral Power Line	MD	: Measurement Distance
E	: Earth Power Line	SD	: Spec Distance
Pk	: Peak Detector	Pol	: Polarisation
QP	: Quasi-Peak Detector	H	: Horizontal Polarisation
Av	: Average Detector	V	: Vertical Polarisation
CDN	: Coupling & decoupling network		

**B1 RF Gain and Output Power**

Test Details:	
Measurement standard	Part 2.1046, Part 90.219(e)(1)
EUT sample number	S01
Modification state	0
SE in test environment	None
SE isolated from EUT	None
EUT set up	Refer to Appendix C

Frequency MHz	Signal Generator input level dBm	Input Cable Loss dB	Level at Spectrum Analyser dBm	Output Cable & Attenuator loss dB	Gain dB	Conducted Output Power dBm	Gain after 10dB input level increase dB
173.3875	-50.98	0.18	-8.69	40.40	82.87	31.71	71.85

Notes: 1.The signal generator input was increased by 10dBs and the level of the output signal remeasured.

As per Annex .3 Policies + Procedures (k) of KDB 935210 D02 Signal Boosters Certification v02 the EUT was tested at compression and 10dB into compression to show AGC operation

Please note that the unit was only tested in the top 5MHz operating Band. The device was tested in the top 5MHz band only, as the lower frequency bands are already covered under TRaC radio test report TRA-017758-00-47-00-D.

**B2 Amplifier Intermodulation Spurious Emissions**

Test Details:	
Measurement standard	Part 2.1053, 90.219(e)(3)
EUT sample number	S01
Modification state	0
SE in test environment	None
SE isolated from EUT	None
EUT set up	Refer to Appendix C

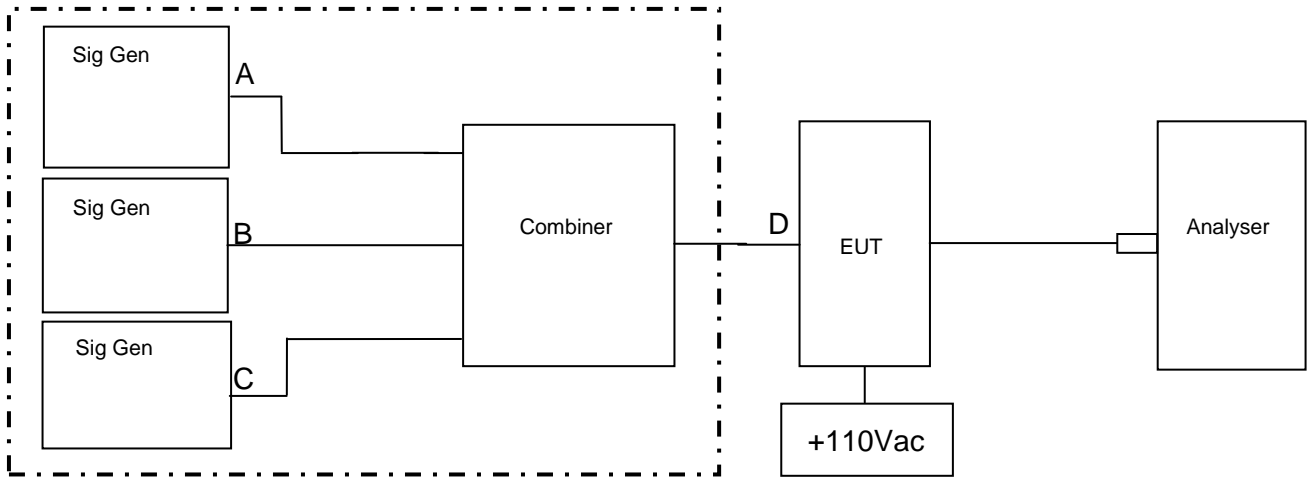

Signal Generator B was varied in frequency to check if intermodulation products were produced.

RF Input Frequency (MHz)			Highest Intermodulation Product Level (dBm)	Limit (dBm)
Upper 5 MHz Band				
168.4125	171.7300	173.3875	170.08MHz @ -17.0dBm	-13

Sweep data is shown on the next page:

**Results**

The EUT was found to comply with the limits

See plots below

As per Annex .3 Policies + Procedures (k) of KDB 935210 D02 Signal Boosters Certification v02 the EUT was tested at compression and 10dB into compression to show AGC operation, worst case results taken.

Please note that the unit was only tested in the top 5MHz operating Band. The device was tested in the top 5MHz band only, as the lower frequency bands are already covered under TRaC radio test report TRA-017758-00-47-00-D.

Lower 5 MHz band - Intermodulation close View

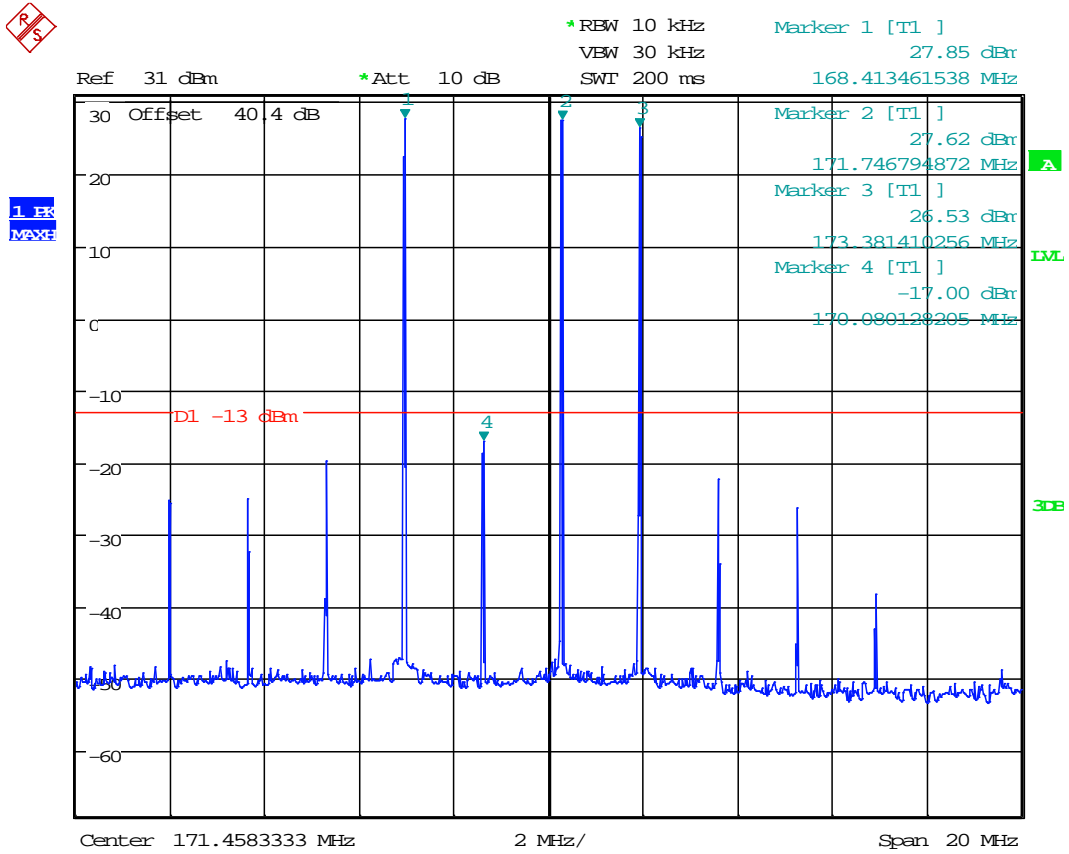

Date: 6.OCT.2014 15:54:38

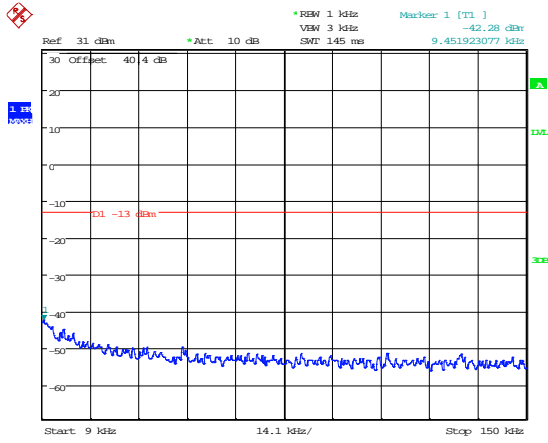

Date: 6.OCT.2014 15:55:31

9-150kHz

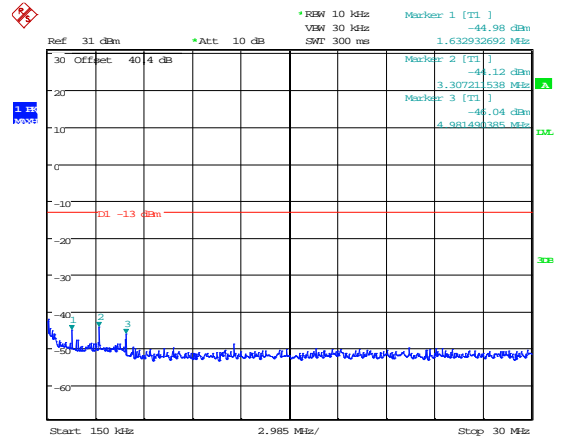

Date: 6.OCT.2014 15:56:26

150kHz – 30MHz

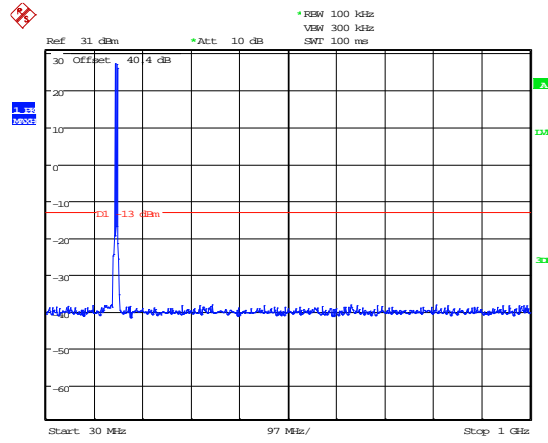

Date: 6.OCT.2014 15:56:52

30MHz – 1GHz

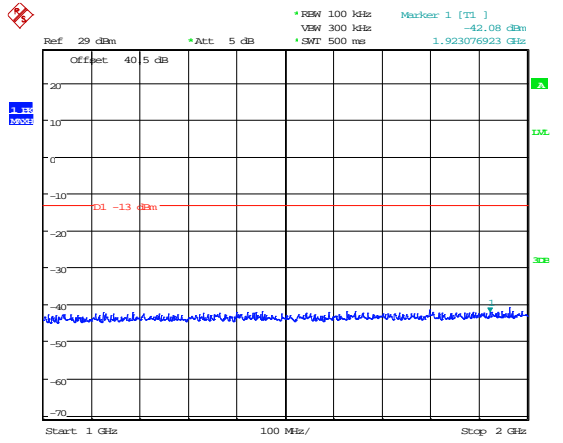

Date: 18.FEB.2014 14:07:34

1GHz – 2GHz

Upper 5 MHz band - Intermodulation close View

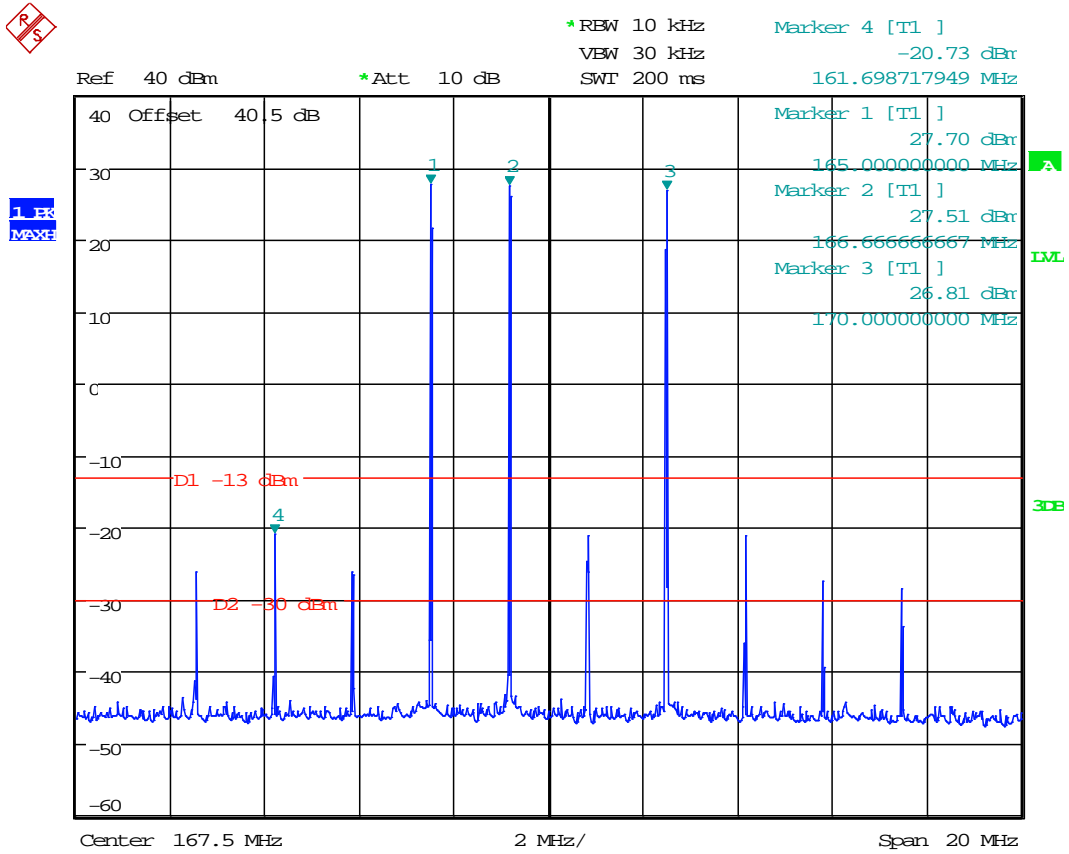

Date: 25.FEB.2014 14:35:15

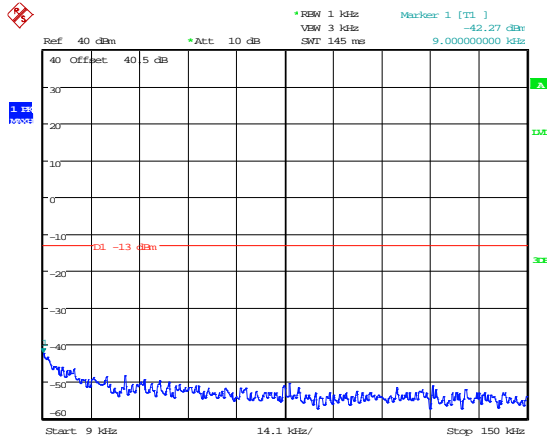

Date: 25.FEB.2014 14:37:36

9-150kHz

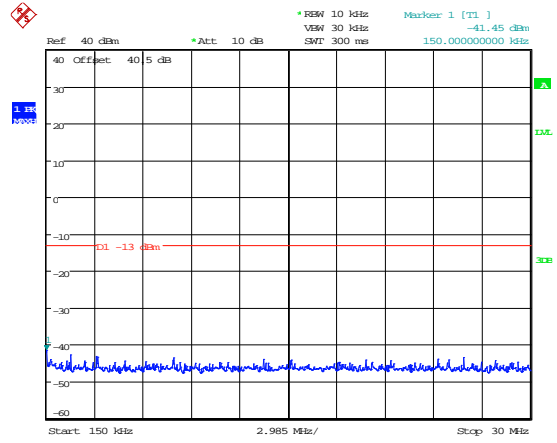

Date: 25.FEB.2014 14:39:01

150kHz – 30MHz

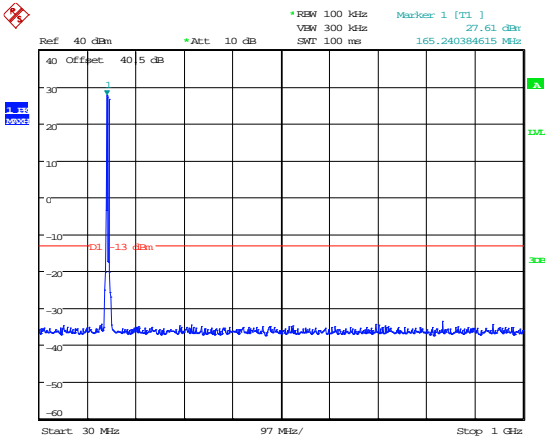

Date: 25.FEB.2014 14:36:24

30MHz – 1GHz

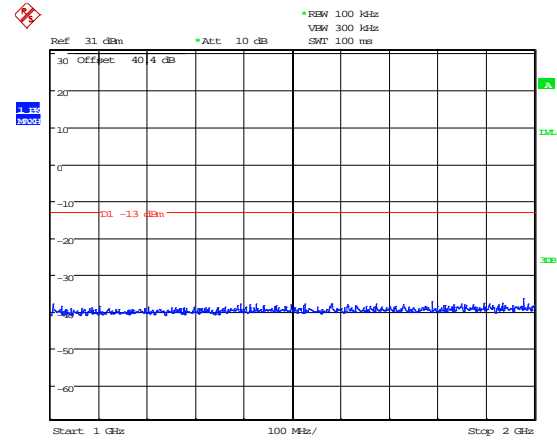

Date: 6.OCT.2014 15:57:14

1GHz – 2GHz



**B3 Amplifier Modulated Channel Test**

<b>Test Details:</b>	
Measurement standard	Part 90.219(a), Part 90.219(e)(4)(ii), 90.210(d)
EUT sample number	S01
Modification state	0
SE in test environment	None
SE isolated from EUT	None
EUT set up	Refer to Appendix C

Modulation Type	Frequency Of Operation Channel (MHz)
Analogue	10.096kHz

As per Annex .3 Policies + Procedures (k) of KDB 935210 D02 Signal Boosters Certification v02 the EUT was tested at compression and 10dB into compression to show AGC operation, worst case results taken.

Please note that the unit was only tested in the top 5MHz operating Band. The device was tested in the top 5MHz band only, as the lower frequency bands are already covered under TRaC radio test report TRA-017758-00-47-00-D.

173.3875 Analogue Signal Generator and EUT

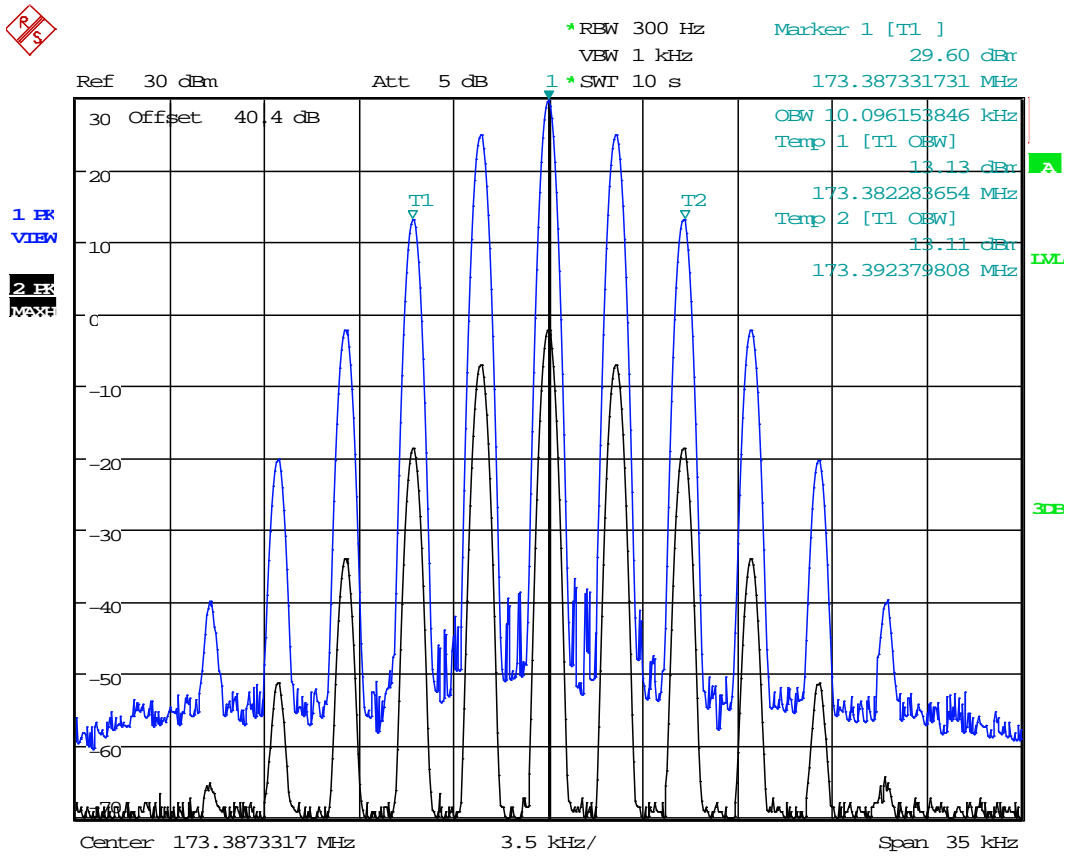

Date: 30.SEP.2014 15:11:27

The above plots depicting the output wavelshape show no measurable distortion visible when compared to the input signal.

Please note that the unit was only tested in the top 5MHz operating Band. The device was tested in the top 5MHz band only, as the lower frequency bands are already covered under TRaC radio test report TRA-017758-00-47-00-D.

**B4 Spurious Emissions at Antenna Terminals Less than 1MHz**

<b>Test Details:</b>	
Measurement standard	Part 2.1053, 90.219(e)(3), 90.210(d)
EUT sample number	S01
Modification state	0
SE in test environment	None
SE isolated from EUT	None
EUT set up	Refer to Appendix C

Modulation Type	Bandedge	Carrier Frequency (MHz)	Max Level @ bandedge (dBm)
Analogue	Upper	173.3875	-53.23

Please note that the unit was only tested in the top 5MHz operating Band. The device was tested in the top 5MHz band only, as the lower frequency bands are already covered under TRaC radio test report TRA-017758-00-47-00-D.



**B5 Spurious Emissions at Antenna Terminals Greater than 1MHz**

Test Details:	
Measurement standard	Part 2.1053, 90.219(e)(3)
EUT sample number	S01
Modification state	0
SE in test environment	None
SE isolated from EUT	None
EUT set up	Refer to Appendix C

Please note that the unit was only tested in the top 5MHz operating Band. The device was tested in the top 5MHz band only, as the lower frequency bands are already covered under TRaC radio test report TRA-017758-00-47-00-D.

**Top channel**

Frequency Range (MHz)	Freq. of Emission (MHz)	Measured Level (dBm)	Attenuator & Cable Losses (dB)	Spurious Emission Level (dBm)	Limit dBm
9kHz - 2GHz	No Significant Emissions Within 20 dB of the Limit				-13

Limit is determined by the outermost step of the emissions mask and is calculated as follows:

At least  $43 + 10 \log P$  dB

$$(10 \log P_{\text{watts}}) - (43 + 10 \log (P_{\text{watts}} * 1000)) = \text{LIMIT} = -13 \text{ dBm}$$

**Result**

The EUT was found to comply with the limits

Spurious Emissions at Antenna Terminals Greater than 1MHz 173.3875MHz

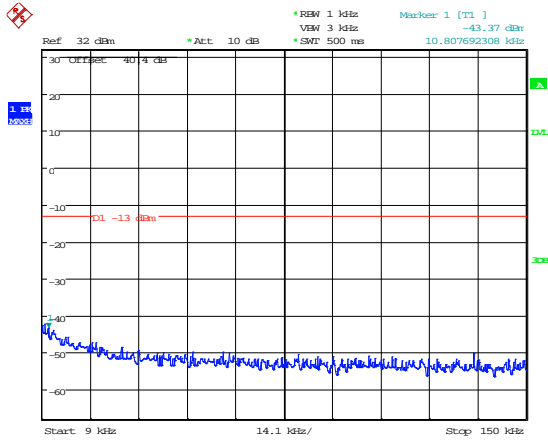

Date: 6.OCT.2014 11:20:35

9-150kHz

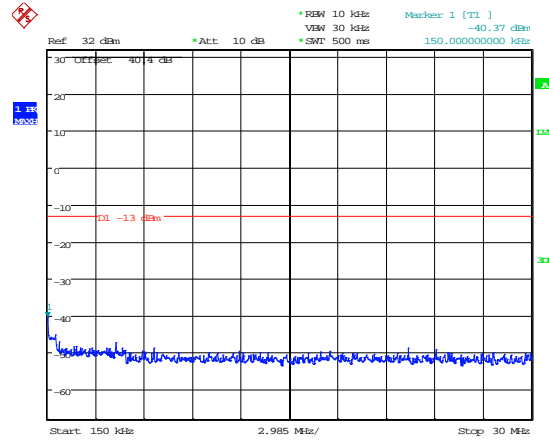

Date: 6.OCT.2014 11:21:04

150kHz – 30MHz

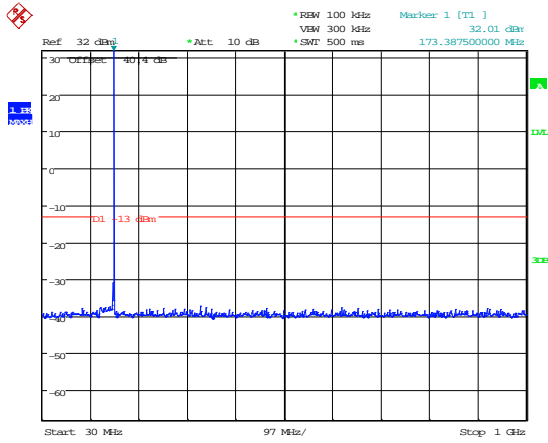

Date: 6.OCT.2014 11:19:00

30MHz – 1GHz

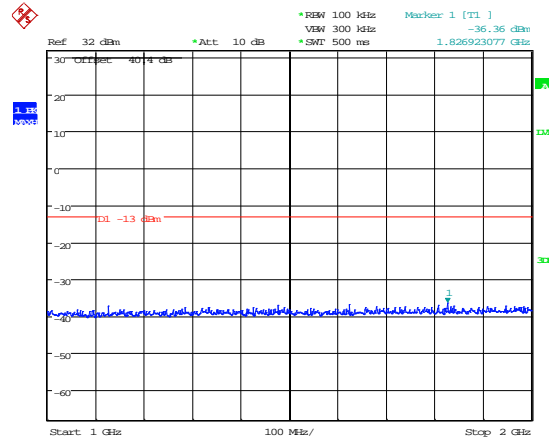

Date: 6.OCT.2014 11:19:46

1GHz – 2GHz

**B6 Noise at Antenna Terminals**

<b>Test Details:</b>	
Measurement standard	90.219(e)(2)
EUT sample number	S01
Modification state	0
SE in test environment	None
SE isolated from EUT	None
EUT set up	Refer to Appendix C

Compliance with these levels will be deemed satisfaction of the good engineering practice requirement. In a 10 kHz measurement bandwidth:

- (1) the ERP of noise within the signal booster passband should not exceed  $-43\text{dBm}$ ;  
and
- (2) the ERP of noise on spectrum more than 1 MHz outside of the signal booster passband should not exceed  $-70\text{ dBm}$ .
- (3) The noise figure of a signal booster must not exceed 9 dB in either direction

See appendix D for manufactures declaration on good engineering practice.

IN BAND AMPLIFIER NOISE – Upper 5 MHz Band

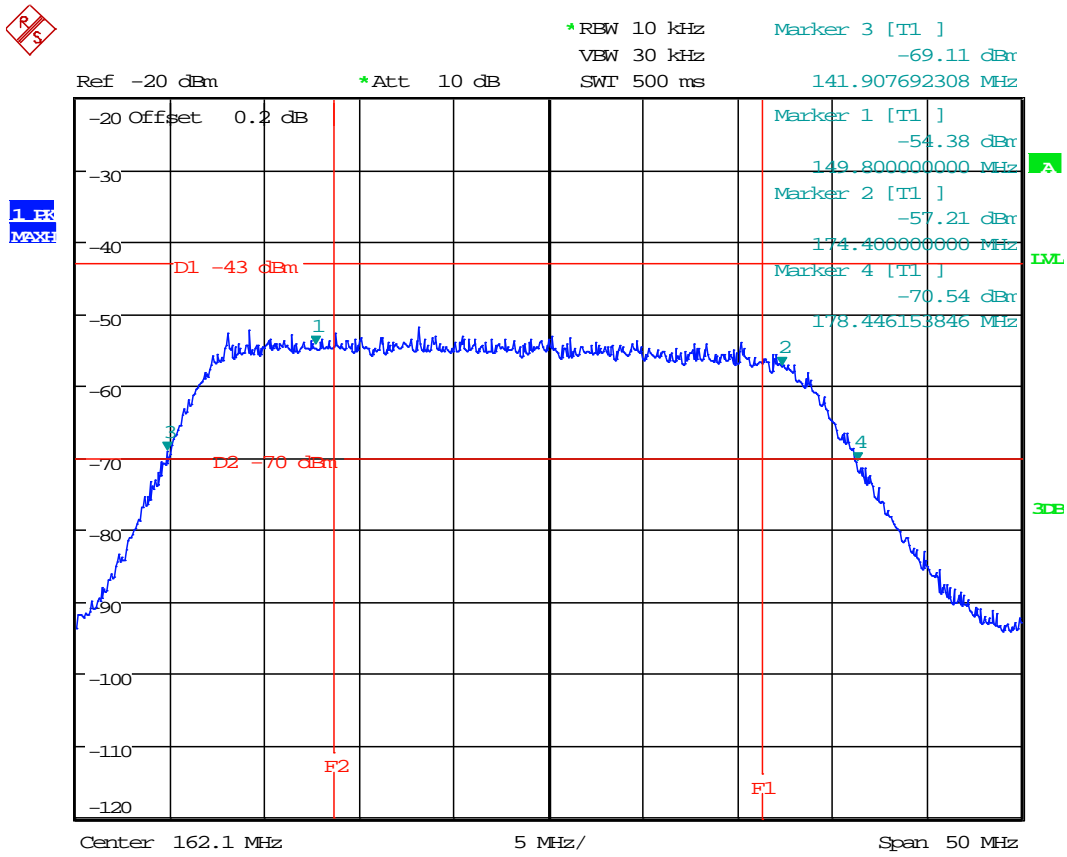

Date: 6.OCT.2014 12:13:48



## Signal booster noise figure

Test equipment set up:-

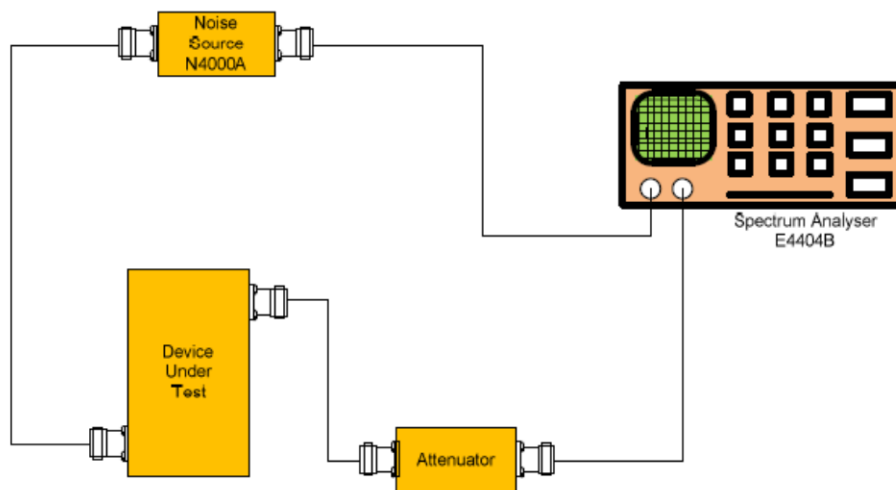

## Result

Plots for noise figure, taken with the 18MHz filter applied at maximum gain with 70dB external attenuators in the test set up

Frequency (MHz)	Noise Figure dB
173.3875	7.67

General notes about measurement setup:

- 1) The spectrum analyser has the noise figure measurement personality enabled.

Please note that the unit was only tested in the top 5MHz operating Band. The device was tested in the top 5MHz band only, as the lower frequency bands are already covered under TRaC radio test report TRA-017758-00-47-00-D.

Noise Figure – 173.9875 MHz

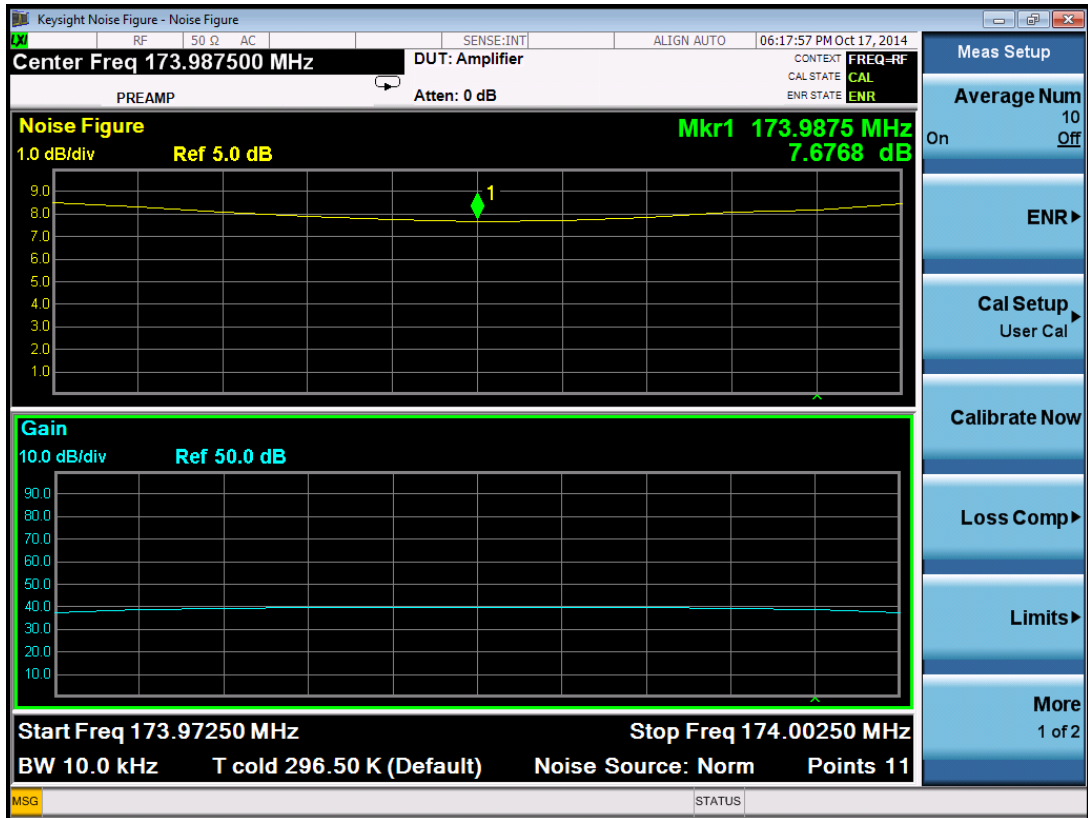

**B7 Radiated Electric Field Emissions**

Preliminary scans were performed using a peak detector with the RBW = 100kHz. The radiated electric field emission test applies to all spurious and harmonic emissions. The EUT was set to transmit as required.

The following test site was used for final measurements as specified by the standard tested to:

3m open area test site :                       3m alternative test site :

The effect of the EUT set-up on the measurements is summarised in note (c) below.

<b>Test Details:</b>	
Measurement standard	Title 47 of the CFR: Part 90.219(e)(3), RSS-131 Section 4.4
Frequency range	30 MHz – 2 GHz
EUT sample number	S01
Modification state	0
SE in test environment	None
SE isolated from EUT	None
EUT set up	Refer to Appendix C

**Bottom Frequency**

FREQUENCY RANGE	FREQ. (MHz)	ERP/EIRP (dBm)	LIMIT (dBm)
30MHz - 2GHz	No Significant Emissions Within 20 dB of the Limit		-13

Please note that the unit was only tested in the top 5MHz operating Band. The device was tested in the top 5MHz band only, as the lower frequency bands are already covered under TRaC radio test report TRA-017758-00-47-00-D.

**Top Frequency**

FREQUENCY RANGE	FREQ. (MHz)	ERP/EIRP (dBm)	LIMIT (dBm)
30MHz - 2GHz	No Significant Emissions Within 20 dB of the Limit		-13

**Result**

The EUT was found to comply with the limits

**Notes:**

1. Emissions Checked up to 10 times Fc.
2. The unit was mounted on a turntable and rotated through 360° and in 3 orthogonal planes to find the worst case emission.
3. For Frequencies below 1 GHz, RBW = 120 kHz, testing was performed with CISPR16 compliant test receiver with QP detector. Above 1 GHz tests were performed using a spectrum analyser using the following settings:

Peak Detector                  RBW = 1MHz; VBW = ≥RBW

4. Limit is determined as the outermost step of the emissions mask and is calculated as follows.

At least 43 + 10 log P dB

$$(10\log P_{\text{watts}}) - (43 + 10\log (P_{\text{watts}} * 1000)) = \text{LIMIT} = -13 \text{ dBm}$$

The upper and lower frequency of the measurement range was decided according to 47 CFR Part 2.1057.

- (a) Where results have been measured at one distance, and a signal level displayed at another, the results have been extrapolated using the following formula:

$$\text{Extrapolation (dB)} = 20 \log_{10} \left( \frac{\text{measurement distance}}{\text{specification distance}} \right)$$

- (b) The levels may have been rounded for display purposes.
- (c) The following table summarises the effect of the EUT operating mode, internal configuration and arrangement of cables / samples on the measured emission levels :

	See (i)	See (ii)	See (iii)	See (iv)
Effect of EUT operating mode on emission levels	✓			
Effect of EUT internal configuration on emission levels	✓			
Effect of Position of EUT cables & samples on emission levels	✓			
(i)      Parameter defined by standard and / or single possible, refer to Appendix D (ii)     Parameter defined by client and / or single possible, refer to Appendix D (iii)    Parameter had a negligible effect on emission levels, refer to Appendix D (iv)    Worst case determined by initial measurement, refer to Appendix D				

Radiated Electric Field Emissions 173.3875MHz

30MHz – 1GHz

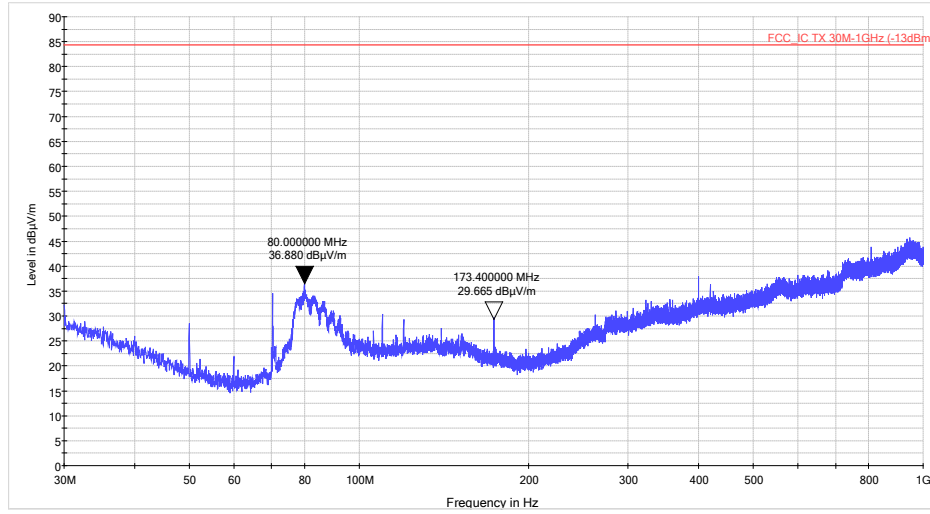

1GHz – 2GHz

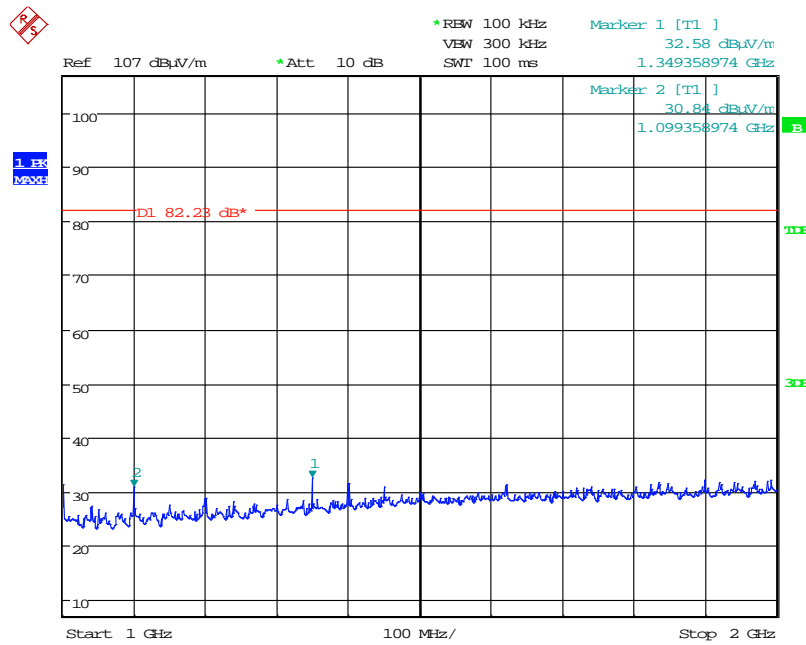

Date: 7.OCT.2014 14:45:05

**B8 Passband Gain & Bandwidth**

Test Details:	
Measurement standard	RSS-131 Section 4.2
	D.3 Policies + Procedures (k) of KDB 935210 D02 Signal Boosters Certification v02
EUT sample number	30 MHz – 2 GHz
Modification state	S01
SE in test environment	0
SE isolated from EUT	None
EUT set up	Refer to Appendix C

Frequency MHz	F <sub>l</sub> MHz	F <sub>h</sub> MHz	20 dB Bandwidth
173.3875 MHz	173.358653	173.416346	57.69kHz

1. See below for plots showing passband gain & bandwidth

With the aid of a CW Swept signal generator and spectrum analyser, the bandwidth and frequency response of the open channel (i.e. at the point where the gain has fallen by 20 dB) is measured. This measurement shows the gain-versus-frequency response of the open channel from the midband frequency  $f_0$  of the channel up to at least  $f_0 + 250\%$  of the 20 dB bandwidth.

Please note that the unit was only tested in the top 5MHz operating Band. The device was tested in the top 5MHz band only, as the lower frequency bands are already covered under TRaC radio test report TRA-017758-00-47-00-D.

Upper 5 MHz band – 173.3875MHz

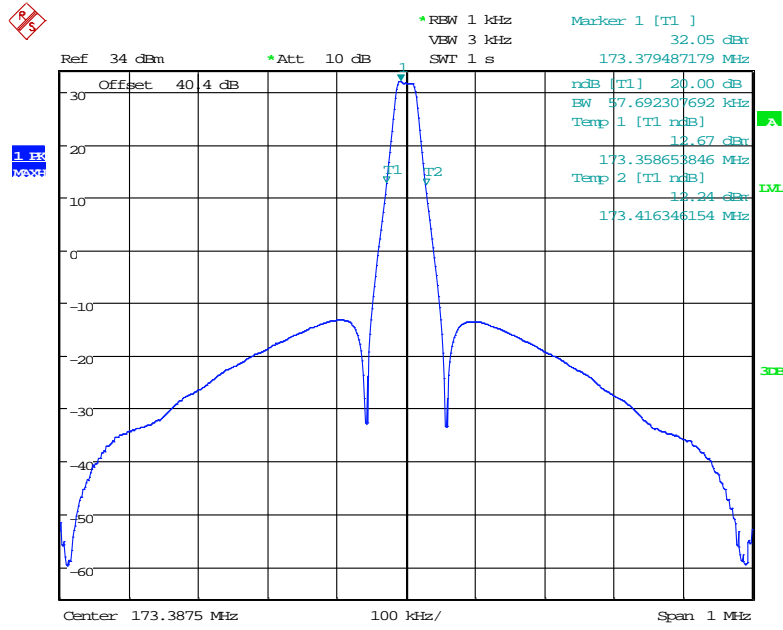

Date: 6.OCT.2014 14:33:39

**Appendix C:****Additional Test and Sample Details**

This appendix contains details of:

1. The samples submitted for testing.
2. Details of EUT operating mode(s)
3. Details of EUT configuration(s) (see below).
4. EUT arrangement (see below).

Throughout testing, the following numbering system is used to identify the sample and its modification state:

**Sample No:** Sxx Mod w

where:

xx = sample number           eg. S01  
w = modification number       eg. Mod 2

The following terminology is used throughout the test report:

**Support Equipment (SE)** is any additional equipment required to exercise the EUT in the applicable operating mode. Where relevant SE is divided into two categories:

SE in test environment: The SE is positioned in the test environment and is not isolated from the EUT (e.g. on the table top during REFE testing).

SE isolated from the EUT: The SE is isolated via filtering from the EUT. (e.g. equipment placed externally to the ALSR during REFE testing).

**EUT configuration** refers to the internal set-up of the EUT. It may include for example:

- Positioning of cards in a chassis.
- Setting of any internal switches.
- Circuit board jumper settings.
- Alternative internal power supplies.

Where no change in EUT configuration is **possible**, the configuration is described as "single possible configuration".

**EUT arrangement** refers to the termination of EUT ports / connection of support equipment, and where relevant, the relative positioning of samples (EUT and SE) in the test environment.

For further details of the test procedures and general test set ups used during testing please refer to the related document "EMC Test Methods - An Overview", which can be supplied by TRaC Global upon request.



**C1) Test samples**

The following samples of the apparatus were submitted by the client for testing :

Sample No.	Description	Identification
S01	D-CSR-3302-8-140-170-DP-AC	26846G

The following samples of apparatus were submitted by the client as host, support or drive equipment (auxiliary equipment):

Sample No.	Description	Identification
None		

The following samples of apparatus were supplied by TRaC Global as support or drive equipment (auxiliary equipment):

Identification	Description
None	

**C2) EUT Operating Mode During Testing.**

During testing, the EUT was exercised as described in the following tables :

Test	Description of Operating Mode
All tests detailed in this report	Receiving a signal to ensure EUT is operating a maximum gain and maximum output power.

**C3) EUT Configuration Information.**

The EUT was submitted for testing in one single possible configuration.

**C4) List of EUT Ports**

The tables below describe the termination of EUT ports:

Sample : S01  
Tests : Conducted

Port	Description of Cable Attached	Cable length	Equipment Connected
U/L DAS	Coaxial	>1m	Measurement System or 50Ω Load
D/L DAS	Coaxial	>1m	Measurement System or 50Ω Load
U/L Donor Antenna	Coaxial	>1m	Measurement System or 50Ω Load
D/L Donor Antenna	Coaxial	>1m	Measurement System or 50Ω Load

Sample : S01  
Tests : Radiated Emissions

Port	Description of Cable Attached	Cable length	Equipment Connected
U/L DAS	Coaxial	>1m	Measurement System or 50Ω Load
D/L DAS	Coaxial	>1m	Measurement System or 50Ω Load
U/L Donor Antenna	Coaxial	>1m	Measurement System or 50Ω Load
D/L Donor Antenna	Coaxial	>1m	Measurement System or 50Ω Load

\* Only connected during setup.

**C5) Details of Equipment Used**

TRaC No	Equipment Type	Equipment Description	Manufacturer	Last Cal Calibration	Calibration Period	Due For Calibration
UH187	ESHS10	Receiver	R&S	19/02/2014	12	19/02/2015
UH191	CBL611/A	Bilog	Chase	13/12/2012	24	13/12/2014
UH281	FSU46	Spectrum Analyser	R&S	26/03/2014	12	26/03/2015
UH387	ATS	Chamber 1	Rainford EMC	04/07/2013	24	04/07/2015
UH388	ATS	Chamber 2	Rainford EMC	04/07/2013	24	04/07/2015
UH396	ENV216	Lisn	R&S	22/05/2014	12	22/05/2015
UH403	ESCI 7	Recevier	R&S	12/08/2013	12	12/08/2014
UH405	FSU26	Spectrum Analyser	R&S	16/04/2014	12	16/04/2015
L138	3115	1-18GHz Horn	EMCO	17/10/2013	24	17/10/2015
L139	3115	1-18GHz Horn	EMCO	20/09/2013	24	20/09/2015
L176	2042	Signal Generator	Marconi	29/11/2013	12	29/11/2014
L254	2042	Signal Generator	Marconi	08/01/2014	12	08/01/2015
L290	CBL611/A	Bilog	Chase	13/12/2012	24	13/12/2014
L352	ESVS10	Receiver	R&S	21/03/2014	12	21/03/2015
L572	8449B	Pre Amp	Agilent	11/02/2014	12	11/02/2015
REF909	FSU26	Spectrum Analyser	R&S	12/02/2014	12	12/02/2015
REF916	SMBV100A	Signal Generator	R&S	19/02/2014	12	19/02/2015
REF940	ATS	Radio Chamber - PP	Rainford EMC	09/07/2013	24	09/07/2015
REF978	HL 050	Log Periodic Antenna	R&S	08/04/2014	24	08/04/2016

**Appendix D:**

**Additional Information**

**User manual warnings - Class of Booster and Guidelines for Good Working Practice.**

A number of statements regarding FCC compliance and recommendations of good working practice to enable co-existence of systems without interference to other users have been incorporated in the user manual as follows:

**Compliance with FCC**

	<p><b>WARNING:</b> This is NOT a CONSUMER device. This device is designed for installation by FCC LICENCEES and QUALIFIED INSTALLERS. You must have an FCC LICENCE or express consent of an FCC Licensee to operate this device.</p> <p>Depending on the software configuration, this device can operate either as a Class A or Class B signal booster. You MUST register Class B signal boosters (as defined in 47 CFR 90.219) online at <a href="http://www.fcc.gov/signal-boosters/registration">www.fcc.gov/signal-boosters/registration</a>.</p> <p>Unauthorized use may result in significant forfeiture penalties, including penalties in excess of \$100,000 for each continuing violation.</p> <p>The installation procedure must result in the signal booster complying with FCC requirements 90.219(d). In order to meet FCC requirements <b>90.219(d)</b>, it may be necessary for the installer to reduce the UL and/or DL output power for certain installations.</p>
---	---

**FCC Part 15**

This device complies with part 15 of the FCC Rules. Operation is subject to the following two conditions:

1. This device may not cause harmful interference, and
2. This device must accept any interference received, including interference that may cause undesired operation.

If not installed and used in accordance with the instructions, this equipment generates, uses and can radiate radio frequency energy. However, there is no guarantee that interference will not occur in a particular installation. If this equipment does cause harmful interference to RF reception, which can be determined by turning the equipment off and on, the user is encouraged to try to correct the interference by one or more of the following measures:

- Reorient or relocate the Donor antenna.
- Increase the separation between the equipment and receiver.
- Connect the equipment into an outlet on a circuit different from that to which the receiver is connected.



## Unauthorized Changes to Equipment

Changes or Modifications not expressly approved by the manufacturer responsible for compliance could void the user's authority to operate the equipment

## FCC RF Exposure Limits

This unit complies with FCC RF exposure limits for an uncontrolled environment. This equipment can only be installed in in-building applications, driving passive or active DAS systems. All antennas must be operated at a minimum distance of 35 cm between the radiator and any person's body.

## Antenna Installation

Installation of an antenna must comply with the FCC RF exposure requirements. The antenna used for this transmitter must be mounted on permanent structures.

The FCC regulation mandate that the EIRP of type A signal boosters should not exceed 5W.

Therefore the max antenna gain allowed for this type of signal booster should be limited to the values given by equation (1) for the service antenna and equation (2) for the donor antenna

### Equation (1) - Max SERVICE antenna gain

Max SERVICE antenna gain (dBi) =  $37 - (33\text{dbi} - \# \text{ of antennas in dbi} - \text{cable losses in dbi})$ .

For example:

No. of Antennas	Cable Losses	Max Allowed Antenna Gain
4	3	$37 - (33-6-3) = 13\text{dBi}$
1	3	$37 - (33-3) = 7\text{dbi}$
10	3	$37 - (33-10-3) = 17\text{dbi}$

### Equation (2) - Max DONOR antenna gain

Max DONOR antenna gain (dBi) =  $37 - (27\text{dbi} - \text{cable losses in dbi})$ .

## Compliance with FCC deployment rule regarding the radiation of noise

Good engineering practice must be used in regard to the signal booster's noise radiation. Thus, the gain of the signal booster should be set so that the EIRP of the output noise from the signal booster should not exceed the level of -43 dBm in 10 kHz measurement bandwidth.

In the event that the noise level measured exceeds the aforementioned value, the signal booster gain should be decreased accordingly.





## FCC Approval Clarification

In general, the ERP of noise on a spectrum more than 1 MHz outside of the pass band should not exceed -70 dBm in a 10 kHz measurement bandwidth.

The VHF D-CSR3302 signal booster has a noise level of -60 to -70 dBm in 10 kHz measurement at 1 MHz spectrum outside the passband of the signal booster and an *in-band* noise level at around -50 dBm in a 10 kHz bandwidth. Therefore, the noise at the antenna input port should be calculated based on equation (3).

**Equation (3) - Input Noise to service antenna**

Input Noise to service antenna:

$-50 \text{ dBm} + \text{Service Antenna gain} - \text{Antenna splitter losses in dBi} - \text{cable loss in dB}$

Example:

Signal booster connected to 10 service antennas with a 100m long ½ inch cable.

Losses of such a cable with the connectors = ~ 7dB

Gain = ~ 2 dBi

Assuming 10 service antennas: antenna splitter losses = 11 dB

Based on equation (3) Input the In-Band antenna noise (to the antenna) =  $-50+2 -7 -11=-66 \text{ dBm}$

*NOTE: In normal practice the antenna duplexing filter would provide -10 to -20dB attenuation at 1MHz from the band edge and the -70dBm out of band value would be easily met. However in lower loss DAS distribution systems it may be necessary to add further filtering to ensure that the -70dBm is met.*

Conclusion:

Good engineering practice requires that in general when the out of band noise measured at the service antenna input is more than -70 dBm per 10 kHz measurement bandwidth, an external band pass filter should be added to attenuate the out of band noise level.



---

## Antenna Specifications and Installation Criteria

---

### WARNING!!!

- The installer is held accountable for implementing the rules required for deployment.
  - Good engineering practice must be used to avoid interference.
  - Output power should be reduced to solve any IMD interference issues.
- 

This chapter provides information on the specifications of the donor and service antennas suitable for operation with this repeater, and on the installation requirements of the antennas.

**NOTE:** The Donor and Mobile antennas can be positioned and installed (without connection to the Repeater) at any time either before or after mounting and grounding the Repeater.

---

### Base (Donor) Antenna

The Base (Donor) antenna is usually installed outdoors and is either a directional antenna such as a Yagi or a Panel antenna.

#### Required Antenna Information

##### You will require the following antenna information:

- Antenna type and characteristics
- Height
- Length and type of coaxial cable required for connecting the Donor antenna to the Repeater and the attenuation.

#### Donor Antenna specifications

- Max DONOR antenna gain (dBi) = 37 – (27dbi - cable losses in dbi).
- Very sharp beam pointed to the BTS.
- Minimum cable and jumper loss = 2dB.

#### Installation Criteria

- Select a location for the Donor antenna and verify that there is enough signal strength at that location.
- Install the Donor Antenna at the designated height.
- The antenna should point to the direction of the base station for maximum input power.
- Verify that the antenna is in the base stations line of sight (raise the antenna if necessary).
- Install the donor antenna at a higher level (i.e. floor) than the mobile antenna.



## Service Antenna Requirements



### WARNING!!!

- a. The installer is held accountable for implementing the rules required for deployment.
- b. Good engineering practice must be used to avoid interference.
- c. Output power should be reduced to solve any IMD interference issues”

The Service antenna type depends on the design of the indoors DAS.

### Required Antenna Information

The following antenna requirements, specifications and site considerations should be met:

- Type of installation – indoor DAS/Radiating Cable
- Service area type and size
- Antenna type and characteristics
- Height
- Length and type of coaxial cable required for connecting the antenna to the Repeater and the attenuation.

### Indoor Installations

#### Recommended Antennas

The following describes the requirements for an omni-directional mobile used for indoor applications.

#### Specifications:

One or a combination of the following antennas can be used: Ceiling Mount Patch antenna, Wall Mount Patch antenna, Corner Reflector.

Choose an antenna with high side lobe attenuation which enables maximum isolation from the service/mobile antenna.

Maximum Antenna Gain = 37 – (33dbi – # of antennas in dbi – cable losses in dbi).

#### Installation Criteria

Determine the antenna installation configuration, according to the transmission requirements and the installation site conditions.

#### Installation requirements:

- An indoor antenna should be installed at a convenient location. It should be free of metallic obstruction.
- Install the Service Antenna at the designated height and tune it roughly toward the Service coverage area.

**Appendix E:**

**Photographs and Figures**

The following photographs were taken of the test samples:

1. Radiated electric field emissions arrangement: front view.
2. Radiated electric field emissions arrangement: close up.

Photograph 1

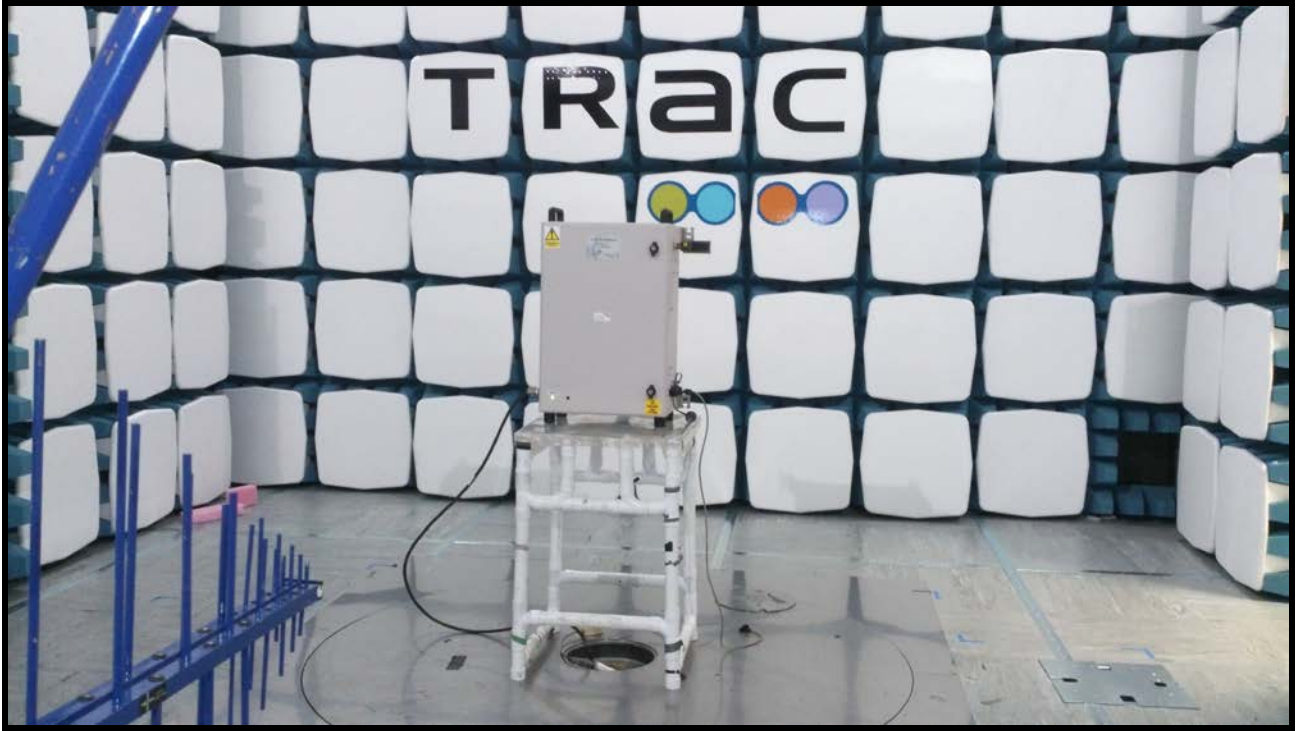



Photograph 2

