

The D-CSR3302 is a channelised Class A repeater product that utilised DSP Software Defined Radio filter techniques to provide 8 RF channel frequencies within a 20MHz window of RF spectrum within the range of 150 – 170MHz.

The Digital Radio board is a 20MHz wide RF module that digitises a 5MHz segment of the 20MHz window, the setting of the 5MHz segment of spectrum is performed at factory initialisation and is not field adjustable. Once an equipment leaves the factory its operating bandwidth is already set by the initialisation and the external duplexing filters used to separate and define the required Part 90 Tx and Rx frequency bands. The unit has a wideband class A VHF amplifier design to operate from 148MHz to 174MHz, the amplifier is pre tested and optimised for the specific 5MHz spectrum window of operation.

In normal operation the repeater would consist of a number of narrow band filters that have been duplexed together to form a common input or output port for single antenna operation. The purpose of the filter / duplexer is to ensure that the equipment operating bandwidth is limited to the band of frequencies required to be amplified/repeater. The filter ensures that noise and any Intermodulation is limited to within the operating transmission band. The filter must prevent any noise reaching the antenna port at the receiver frequencies as any noise at this point will affect the ability to receive. The receiver input filter is used to ensure that only the required input band of frequencies is presented to the DSP module. The filter also ensures that the high level transmit output does not cause overload damage of blocking of the receiver ability to detect the wanted input frequencies.

This document will detail the operation for each of the components and provide explanatory drawings of the system and its application.

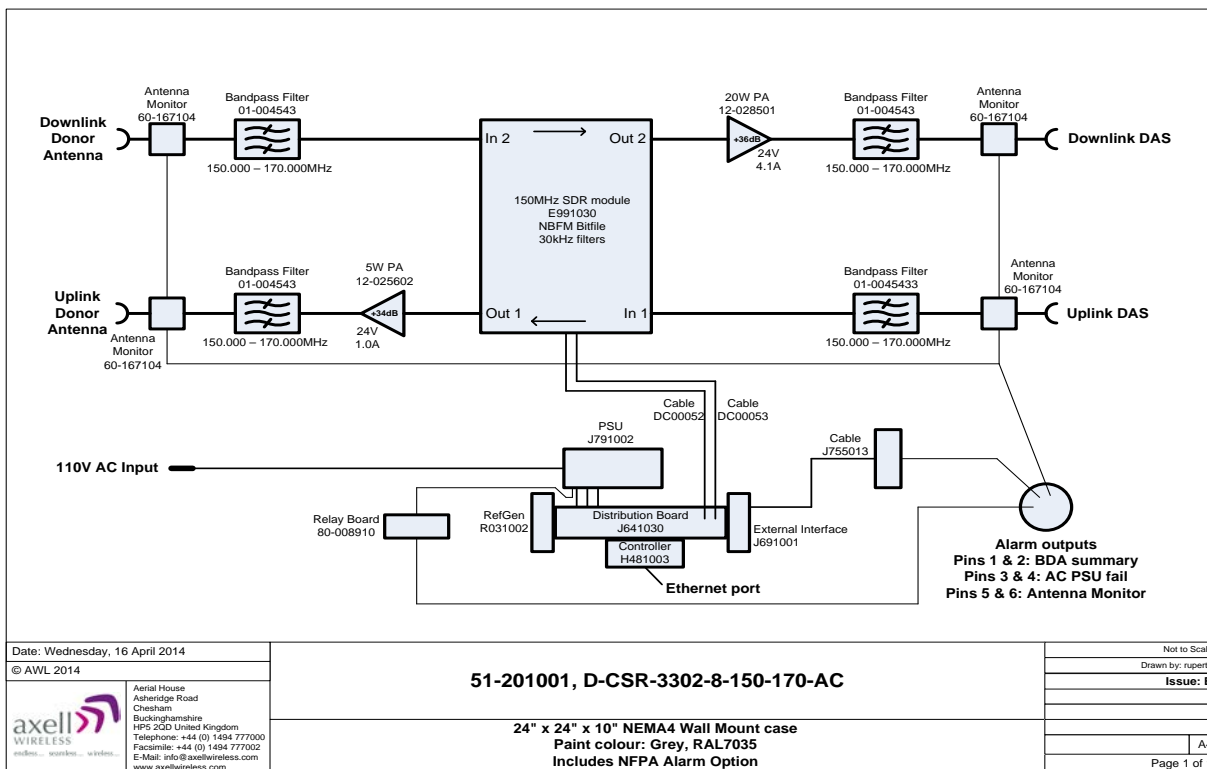

Figure 1. VHF D-CSR3302 for Type approval – Part number 51-201001.

The VHF CSR3302 consists of 4 major components to perform RF amplification of the DL and UL paths.

1. DSP controlled Digital filtering for channel selectivity
2. Downlink amplifier
3. Uplink Amplifier
4. Input and output spectrum defining band pass filters for band selectivity.

There are also a number of supporting Power and Control modules including:

5. PSU
6. Distribution Board
7. Alarm interface
8. Controller
9. Reference Generator
10. Antenna Fault Detector

#### Module Function

1. The DSP controlled digital filter module provides 8 channel selectivity in both the DL and UL directions. The channel filter has 2 bandwidth options of 15 kHz or 30 kHz bandwidth. The module consists on a 30dB gain low noise input amplifier feeding into an analogue to digital convertor which digitises a 5MHz block of the 20MHz input spectrum.

The digitised signal is filtered into the 8 channel windows as set by the frequency and bandwidth information entered. A digital squelch with adjustable threshold is set to enable the signal output above a predetermined input signal level. The digitised filtered output is then fed via a Digital to analogue convertor into a 30dB gain pre driver amplifier to feed the output amplifier.

Whilst the DSP radio module has an operational bandwidth of 20MHz, the exact 5MHz operating window of spectrum is Factory set to the frequency bands defined on the customer order. In situations where the customer frequency range is limited by duplex spacing, the actual operating passband will be factory set to match the duplexer filter bandwidth. Hence it is not possible to set repeater frequencies outside of the duplexer filter operating window.

The repeater is designed to provide a maximum composite power of 33dBm, there is an automatic power levelling algorithm based upon the number of channels enabled for amplification based upon the customer allocation.

The carrier power output follows the rule:

Carriers	1	2	3	4	5	6	7	8
dBm	33	30	28.3	27	26	25.3	24.5	24

The DSP radio board has a wide range ALC for each carrier and can accommodate signal level increase of >30dB without increasing the output power or IMD generation.

Each carrier has an adjustable squelch setting threshold from -108dBm to -40dBm. It is possible for the repeater to be provided with a factory set CTCSS or PL tone squelch to prevent unintentional operation by other users of the same frequency.

2. The Downlink output amplifier provides 31dB of gain and has a P1dB of 44dBm and an IP3 of 54dBm. The amplifier utilises high linearity class A techniques to minimise Intermodulation generation in the presence of multiple carriers.
3. The uplink output amplifier provides 34dB of gain and has a P1dB of 37dBm and an IP3 of 47dBm. The amplifier utilises high linearity class A techniques to minimise Intermodulation generation in the presence of multiple carriers.
4. Band pass filters are fitted at the input and output of the DL and UL RF chains, these filters are used to limits the out of band noise and prevents out-of-band signals from overloading the DSP module.
5. The PSU is a high efficiency 300w switched mode module that converts the 110v AC input to 2 DC output voltages of 24v, 15v and 6.45v.
6. The Distribution board is used to connect the DC power and the RS485 control signals between the associated modules and the PSU / Controller card.
7. The Alarm interface card is used to connect the 2 amplifier alarm contacts and 2 spare external alarms into the controller card.
8. The Controller is based upon a Linux processor and software, which is used to control and monitor the active components within the repeater. A Web browser accessed GUI allows the operator to enter the required channel frequencies and to adjust the Gain and Squelch settings. The controller also provides a summary alarm output upon the failure of any active device.
9. The Reference Generator is used to provide an accurate stable 10MHz Reference signal to the DSP to ensure that the channel selectivity is centred on the wanted channel frequency.

10. The Antenna Fault detector is fitted to meet the NFPA standards for Antenna Integrity Monitoring. This is achieved by feeding a low current DC signal onto the antenna line which when shorted by the antenna connection provides a cable good indication.