

A RADIO TEST REPORT

FOR

Axell Wireless Limited

ON

**D-CSR 4004 Digital Channel Selective Repeater
D-CSR-4004-8-450-470-DP-AC**

DOCUMENT NO. TRA-017758-00-47-01-B

HULL

Unit E, South Orbital Trading Park, Hedon Road, Hull, HU9 1NJ, UK.
T +44 (0)1482 801801 **F** +44 (0)1482 801806 **E** test@tracglobal.com
www.tracglobal.com

TRaC Wireless Test Report : TRA-017758-00-47-01-B

Applicant : Axell Wireless Limited

Apparatus : D-CSR-4004-8-450-470-DP-AC

Specification(s) : CFR47 Part 90, Part 20 & RSS-131

Purpose of Test : Certification

FCCID : NEO51-101SERIES

Certification Number : 8749A-51-101SERIES

Authorised by :



: Radio Product Manager

Issue Date : **30th April 2014**

Authorised Copy Number : *PDF*

Contents

Section 1:	Introduction	4
1.1	General	4
1.2	Tests Requested By	5
1.3	Manufacturer	5
1.4	Apparatus Assessed	5
1.5	Test Result Summary	6
1.6	Equipment Test Conditions	7
1.7	Standard References	8
1.8	Notes Relating To Assessment	9
1.9	Deviations from Test Standards	10
Section 2:	Measurement Uncertainty	11
2.1	Measurement Uncertainty Values	11
Section 3:	Modifications	13
3.1	Modifications Performed During Assessment	13
Appendix A:	Uplink Formal Emission Test Results	14
A1	RF Gain and Output Power	15
A2	Amplifier Intermodulation Spurious Emissions	19
A3	Amplifier Modulated Channel Test	24
A4	Spurious Emissions at Antenna Terminals Less than 1MHz	26
A5	Spurious Emissions at Antenna Terminals Greater than 1MHz	28
A6	Noise at Antenna Terminals	32
A7	Radiated Electric Field Emissions	36
A8	Passband Gain & Bandwidth	41
Appendix B:	Downlink Formal Emission Test Results	43
B1	RF Gain and Output Power	44
B2	Amplifier Intermodulation Spurious Emissions	48
B3	Amplifier Modulated Channel Test	53
B4	Spurious Emissions at Antenna Terminals Less than 1MHz	55
B5	Spurious Emissions at Antenna Terminals Greater than 1MHz	57
B6	Noise at Antenna Terminals	61
B7	Radiated Electric Field Emissions	65
B8	Passband Gain & Bandwidth	70
Appendix C:	Additional Test and Sample Details	72
Appendix D:	Additional Information	78
Appendix E:	Photographs and Figures	93

Section 1:**Introduction****1.1 General**

This report contains an assessment of an apparatus against Electromagnetic Compatibility Standards based upon tests carried out on samples submitted to the Laboratory.

Test performed by: TRaC Global []
Unit E
South Orbital Trading Park
Hedon Road
Hull, HU9 1NJ.
United Kingdom.

Telephone: +44 (0) 1482 801801
Fax: +44 (0) 1482 801806

TraC Global [X]
Unit 1
Pendle Place
Skelmersdale
West Lancashire, WN8 9PN
United Kingdom

Telephone: +44 (0) 1695 556666
Fax: +44 (0) 1695 577077

Email: test@tracglobal.com
Web site: <http://www.tracglobal.com>

Tests performed by: D Winstanley, S Hodgkinson

Report author: D Winstanley

This report must not be reproduced except in full without prior written permission from TRaC Global.

1.2 Tests Requested By

This testing in this report was requested by :

Aerial House
Asheridge Road
Chesham
Buckinghamshire
HP5 1TU

1.3 Manufacturer

Aerial House
Asheridge Road
Chesham
Buckinghamshire
HP5 1TU

1.4 Apparatus Assessed

The following apparatus was assessed 7th March 2014 – 24th April 2014

D-CSR-4004-8-450-470-DP-AC

The D-CSR-4004 is a band settable/channel selective device.

For the purposes of testing the device was setup to operating the following bands.

Lower 5MHz Band 450.0 MHz – 455.0 MHz

Middle 5MHz Band 457.5 MHz – 462.5 MHz

Upper 5MHz Band 465.0 MHz – 470.0 MHz

There are up to 8 selectable channels available in each 5MHz band.

The channels were selected dependent upon each test requirement.

Please see KBD Tracking number 522260 for further information.

1.5 Test Result Summary

Full details of test results are contained within Appendix A. The following table summarises the results of the assessment.

The statements relating to compliance with the standards below apply ONLY as qualified in the notes and deviations stated in sections 1.6 to 1.7 of this test report.

Full details of test results are contained within Appendix A. The following table summarises the results of the assessment.

Test Type	FCC Part	RSS-131 Rule Part	Appendix in Report	Result
RF Gain and Power Output	90.219(d)(3)	4.3	A1 & B1	Pass
Intermodulation Spurious Emissions	90.219(d)(6)	N/A	A2 & B2	Pass
Occupied Bandwidth & Modulation	90.219(4)(e)(iii) 90.210(c)	N/A	A3 & B3	Pass
Spurious Emissions at Antenna Terminals Less than 1MHz	90.219(d)(3) 90.210(c)	N/A	A4 & B4	Pass
Spurious Emissions at Antenna Terminals Greater than 1MHz	90.219(d)(3)	N/A	A5 & B5	Pass
Noise At Antenna Terminals	90.219(d)(6) 90.219(e)(2)	N/A	A6 & B6	Pass
Field Strength of Spurious Emissions	90.219(d)(3)	4.3.2	A7 & B7	Pass
Passband Gain & 20dB bandwidth	N/A	4.2	A8 & B8	Pass
Frequency Stability	90.213	4.4	N/A(note 1)	N/A
Transient behaviour	90.214	4.4	N/A(note 2)	N/A
Audio Frequency Response (a)	TIA EIA-603.3.2.6	4.5	N/A	N/A
Modulation Limiting	TIA EIA-603.3.2.6	N/A	N/A	N/A
Signal Booster Labelling Requirements	20.21(f)(1)(ii)	5.2	N/A	N/A

Notes:

1 The EUT does not contain modulation circuitry, therefore the test was not performed.

2 The EUT is not a keyed carrier system, therefore the test was not performed.

Abbreviations used in the above table:

CFR : Code of Federal Regulations
REFE : Radiated Electric Field Emissions
A Uplink Results Appendix

ANSI : American National Standards Institution
PLCE : Power Line Conducted Emissions
B Downlink Results Appendix

1.6 Equipment Test Conditions

Product class:	Uplink	Class A <input checked="" type="checkbox"/> Class B <input type="checkbox"/>
	Downlink	Class A <input checked="" type="checkbox"/> Class B <input type="checkbox"/>
Product Use:	Private Land Mobile Repeater	
Supply Voltages:	Vnom	110Vac
Note: Vnom voltages are as stated above unless otherwise shown on the test report page		
Equipment Category:	Single channel	<input type="checkbox"/>
	Two channel	<input type="checkbox"/>
	Multi-channel	<input checked="" type="checkbox"/>
Test Location	TRaC Global	
	Skelmersdale	<input type="checkbox"/>
	Hull	<input checked="" type="checkbox"/>
	Other	<input type="checkbox"/> Please Specify

1.7 Standard References

47 CFR 2	Code of Federal Regulations, Title 47, Part 2, "Frequency allocations and Radio Telemetry Matters; General Rules and Regulations"
47 CFR 90	Code of Federal Regulations, Title 47, Part 90, "Land Mobile Radio Service"
47 CFR 15	Code of Federal Regulations, Title 47, Part 15, "Radio Frequency Devices" Subpart B, "Unintentional Radiators"
C63.4-2003	American National Standards Institute (ANSI), "Methods of Measurement of Radio Noise Emissions from Low Voltage Electrical and Electronic Equipment in the Range 9 kHz to 40 GHz"
RSS-131	Zone Enhancers for the Land Mobile Service
RSS-GEN	General Requirements and Information for the Certification of Radio Apparatus
TIA EIA-603-D	Land Mobile FM or PM Communications Equipment Measurement and Performance Standards

1.8 Notes Relating To Assessment

With regard to this assessment, the following points should be noted:

The results contained in this report relate only to the items tested and were obtained in the period between the date of initial receipt of samples and the date of issue of the report.

The apparatus was set up and exercised using the configurations, modes of operation and arrangements defined in this report only.

Particular operating modes, apparatus monitoring methods and performance criteria required by the standards tested to have been performed except where modified in Section 1.7 of this test report (Deviations from Test Standards).

For emissions testing, throughout this test report, "Pass" indicates that the results for the sample as tested were below the specified limit (refer also to Section 2, Measurement Uncertainty).

Where relevant, the apparatus was only assessed using the monitoring methods and susceptibility criteria defined in this report.

All testing with the exception of testing at the Open Area Test Site was performed under the following environmental conditions:

Temperature	: 17 to 23 °C
Humidity	: 45 to 75 %
Barometric Pressure	: 86 to 106 kPa

All dates used in this report are in the format dd/mm/yy.

This assessment has been performed in accordance with the requirements of ISO/IEC 17025.

1.9 Deviations from Test Standards

There were no deviations from the standards tested to.

Section 2:**Measurement Uncertainty****2.1 Measurement Uncertainty Values**

For the test data recorded the following measurement uncertainty was calculated:

Radio Testing – General Uncertainty Schedule

All statements of uncertainty are expanded standard uncertainty using a coverage factor of 1.96 to give a 95% confidence where no required test level exists.

[1] Adjacent Channel Power

Uncertainty in test result = **1.86dB**

[2] Carrier Power

Uncertainty in test result (Power Meter) = **1.08dB**

Uncertainty in test result (Spectrum Analyser) = **2.48dB**

[3] Effective Radiated Power

Uncertainty in test result = **4.71dB**

[4] Spurious Emissions

Uncertainty in test result = **4.75dB**

[5] Maximum frequency error

Uncertainty in test result (Frequency Counter) = **0.113ppm**

Uncertainty in test result (Spectrum Analyser) = **0.265ppm**

[6] Radiated Emissions, field strength OATS 14kHz-18GHz Electric Field

Uncertainty in test result (14kHz – 30MHz) = **4.8dB**,

Uncertainty in test result (30MHz – 1GHz) = **4.6dB**,

Uncertainty in test result (1GHz – 18GHz) = **4.7dB**

[7] Frequency deviation

Uncertainty in test result = **3.2%**

[8] Magnetic Field Emissions

Uncertainty in test result = **2.3dB**

[9] Conducted Spurious

Uncertainty in test result – Up to 8.1GHz = **3.31dB**

Uncertainty in test result – 8.1GHz – 15.3GHz = **4.43dB**

Uncertainty in test result – 15.3GHz – 21GHz = **5.34dB**

Uncertainty in test result – Up to 26GHz = **3.14dB**

[10] Channel Bandwidth

Uncertainty in test result = **15.5%**

[11] Amplitude and Time Measurement – Oscilloscope

Uncertainty in overall test level = **2.1dB**,
Uncertainty in time measurement = **0.59%**,
Uncertainty in Amplitude measurement = **0.82%**

[12] Power Line Conduction

Uncertainty in test result = **3.4dB**

[13] Spectrum Mask Measurements

Uncertainty in test result = **2.59% (frequency)**
Uncertainty in test result = **1.32dB (amplitude)**

[14] Adjacent Sub Band Selectivity

Uncertainty in test result = **1.24dB**

[15] Receiver Blocking – Listen Mode, Radiated

Uncertainty in test result = **3.42dB**

[16] Receiver Blocking – Talk Mode, Radiated

Uncertainty in test result = **3.36dB**

[17] Receiver Blocking – Talk Mode, Conducted

Uncertainty in test result = **1.24dB**

[18] Receiver Threshold

Uncertainty in test result = **3.23dB**

[19] Transmission Time Measurement

Uncertainty in test result = **7.98%**

Section 3:

Modifications

3.1 Modifications Performed During Assessment

No modifications were performed during the assessment

Appendix A:**Uplink Formal Emission Test Results**

Abbreviations used in the tables in this appendix:

Spec	: Specification	ALSR	: Absorber Lined Screened Room
Mod	: Modification	OATS	: Open Area Test Site
EUT	: Equipment Under Test	ATS	: Alternative Test Site
SE	: Support Equipment	Ref	: Reference
L	: Live Power Line	Freq	: Frequency
N	: Neutral Power Line	MD	: Measurement Distance
E	: Earth Power Line	SD	: Spec Distance
Pk	: Peak Detector	Pol	: Polarisation
QP	: Quasi-Peak Detector	H	: Horizontal Polarisation
Av	: Average Detector	V	: Vertical Polarisation
CDN	: Coupling & decoupling network		

A1 RF Gain and Output Power

Test Details:	
Measurement standard	Part 2.1046, Part 90.219(d)(3),RSS-131 Section 4.3
EUT sample number	S02
Modification state	0
SE in test environment	None
SE isolated from EUT	None
EUT set up	Refer to Appendix C

Frequency MHz	Signal Generator input level dBm	Input Cable Loss dB	Level at Spectrum Analyser dBm	Output Cable & Attenuator loss dB	Gain dB	Conducted Output Power dBm	Gain after 10dB input level increase dB
450.0125	-53.30	0.20	-4.51	40.7	89.69	36.19	79.43
460.0000	-53.40	0.20	-4.38	40.7	89.92	36.32	79.17
469.9875	-53.30	0.20	-5.31	40.7	88.89	35.39	78.40

Notes: 1.The signal generator input was increased by 10dBs and the level of the output signal remeasured.

As per D.3 Policies + Procedures (k) of KDB 935210 D02 Signal Boosters Certification v02 the EUT was tested at compression and 10dB into compression to show AGC operation

Lower 5 MHz Band					
Frequency	Frequency (MHz)	P _o	Level at Spectrum Analyser (dBm)	Output Cable & Attenuator loss (dB)	Power At Output Point (dBm)
f ₁	451.750	P _{o1}	-7.98	40.7	32.72
f ₂	453.250	P _{o2}	-6.76	40.7	33.94
f ₃	451.000	P _{o3}	-68.06	40.7	-27.36
f ₄	454.000	P _{o4}	-68.84	40.7	-28.14

$$P_{\text{mean}} = P_{o1} + 3\text{dB}$$

P _{o1} (dBm)	P _{mean}	P _{mean} (dBm)
33.94	P _{o1} + 3dB	36.94

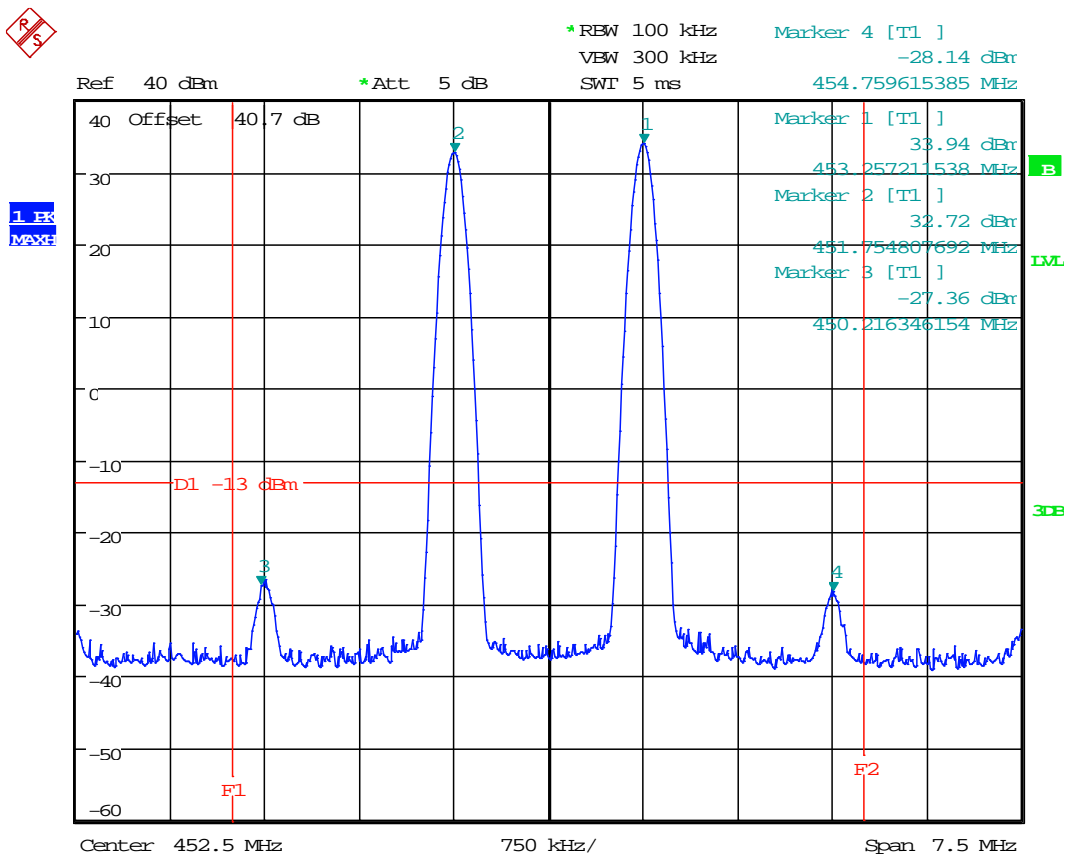

Date: 7.MAR.2014 14:00:47

Middle 5 MHz Band					
Frequency	Frequency (MHz)	P _o	Level at Spectrum Analyser (dBm)	Output Cable & Attenuator loss (dB)	Power At Output Point (dBm)
f ₁	459.250	P _{o1}	-8.12	40.7	32.58
f ₂	460.750	P _{o2}	-8.16	40.7	32.54
f ₃	458.500	P _{o3}	-71.35	40.7	-30.65
f ₄	461.500	P _{o4}	-70.50	40.7	-29.80

$$P_{\text{mean}} = P_{o1} + 3\text{dB}$$

P _{o1} (dBm)	P _{mean}	P _{mean} (dBm)
32.58	P _{o1} + 3dB	35.58

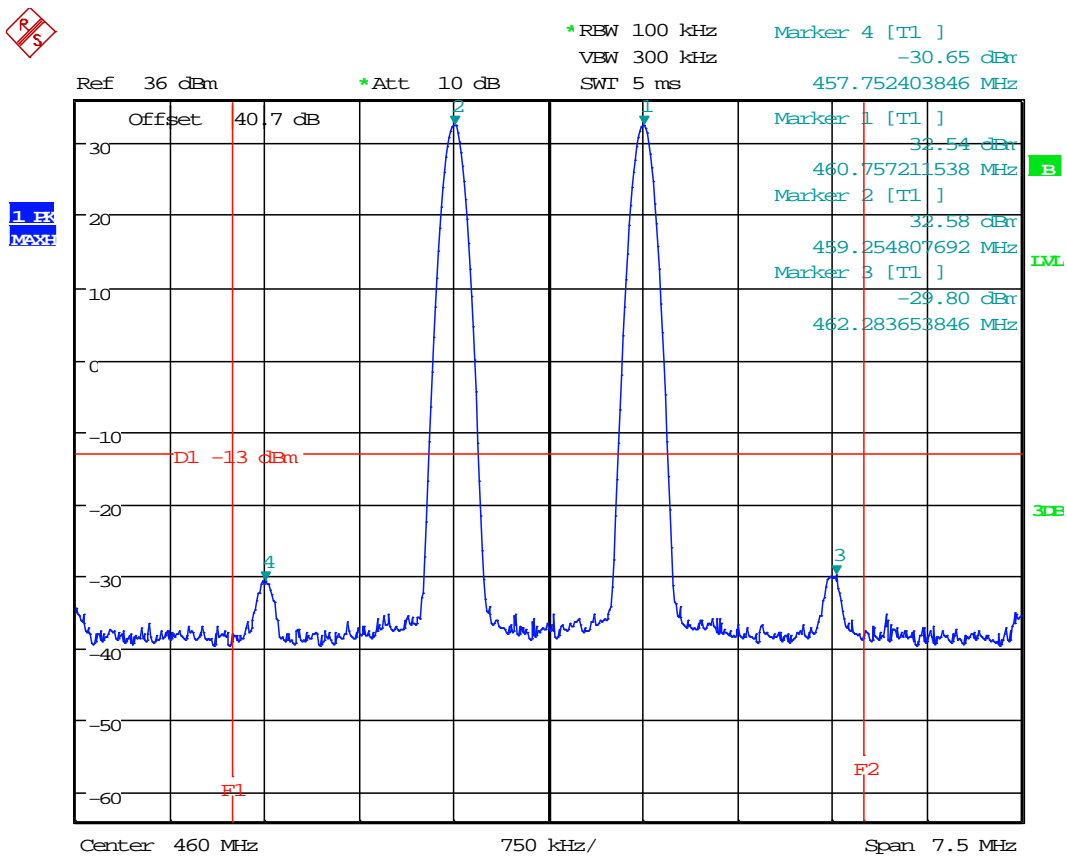

Date: 11.MAR.2014 16:03:53

Upper 5 MHz Band					
Frequency	Frequency (MHz)	P _o	Level at Spectrum Analyser (dBm)	Output Cable & Attenuator loss (dB)	Power At Output Point (dBm)
f ₁	466.750	P _{o1}	-8.11	40.7	32.59
f ₂	468.250	P _{o2}	-8.61	40.7	32.09
f ₃	466.000	P _{o3}	-60.60	40.7	-19.90
f ₄	469.000	P _{o4}	-61.89	40.7	-21.19

$$P_{\text{mean}} = P_{o1} + 3\text{dB}$$

P_{o1} (dBm) P_{mean} P_{mean} (dBm)
 $P_{o1} + 3\text{dB}$

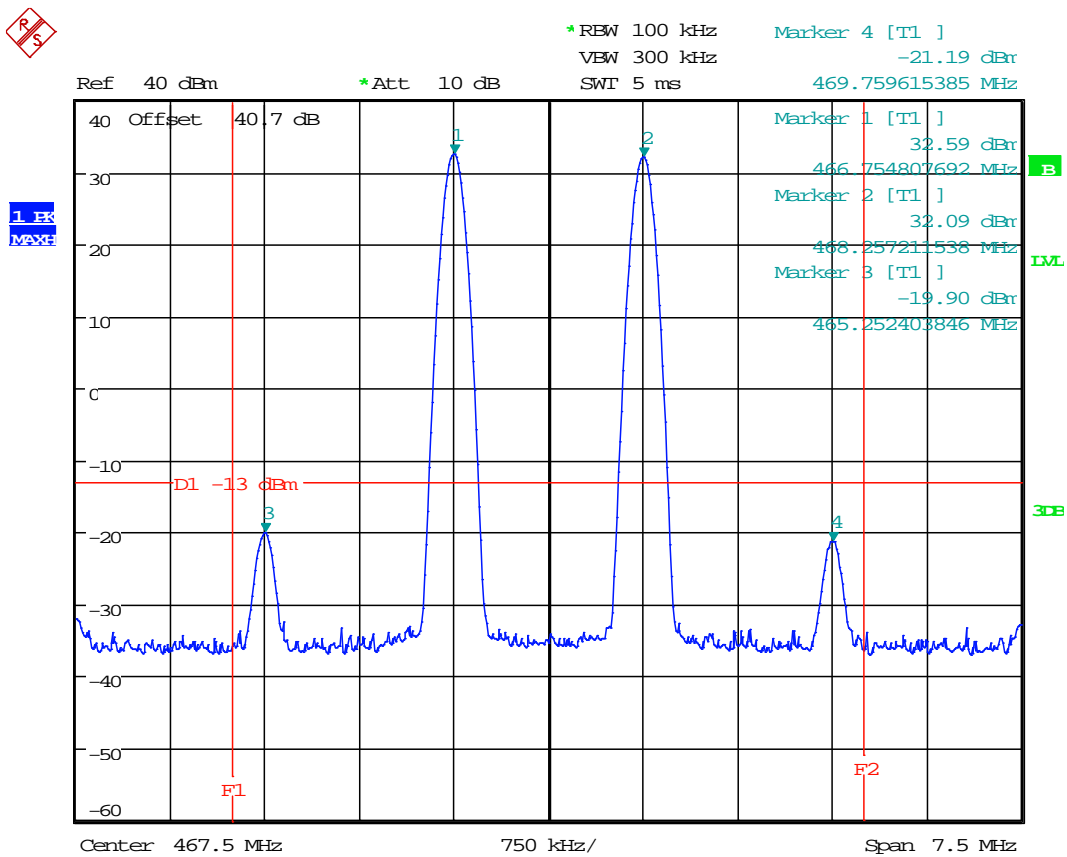

Date: 11.MAR.2014 11:27:37

A2 Amplifier Intermodulation Spurious Emissions

Test Details:	
Measurement standard	Part 2.1053, 90.219(d)(6)
EUT sample number	S02
Modification state	0
SE in test environment	None
SE isolated from EUT	None
EUT set up	Refer to Appendix C

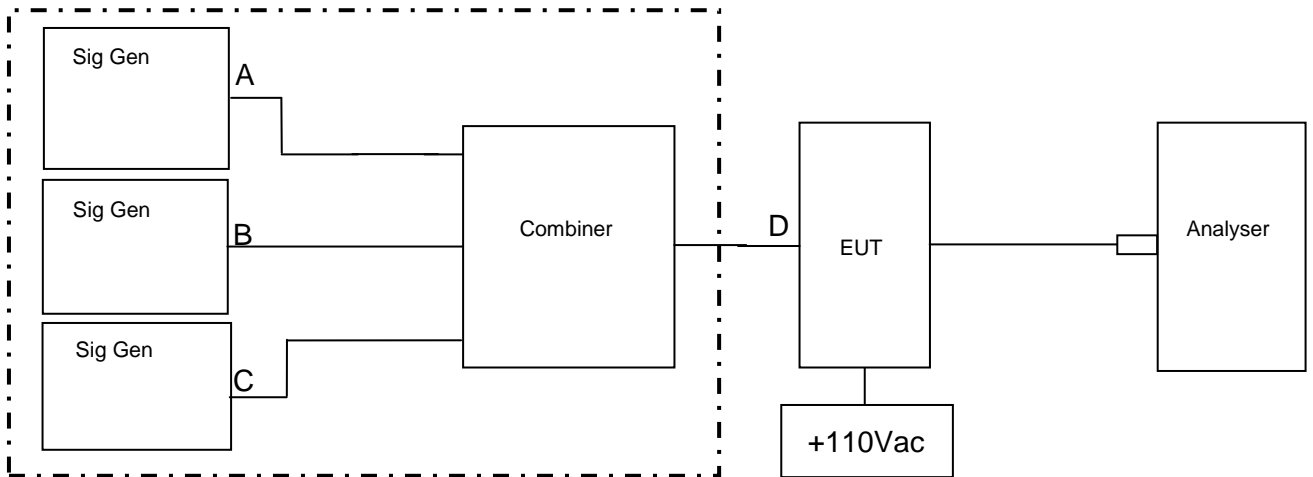

Signal Generator B was varied in frequency to check if intermodulation products were produced.

RF Input Frequency (MHz)			Highest Intermodulation Product Level (dBm)	Limit (dBm)
Lower 5 MHz Band				
450.0125	451.666	454.9875	-34.48 dBm @ 448.333 MHz	-13
Upper 5 MHz Band				
465.0125	466.666	469.9875	-16.00 dBm @ 468.333 MHz	-13

Sweep data is shown on the next page:

Results

The EUT was found to comply with the limits

See plots below

As per D.3 Policies + Procedures (k) of KDB 935210 D02 Signal Boosters Certification v02 the EUT was tested at compression and 10dB into compression to show AGC operation, worst case results taken.

Lower 5 MHz band - Intermodulation close View

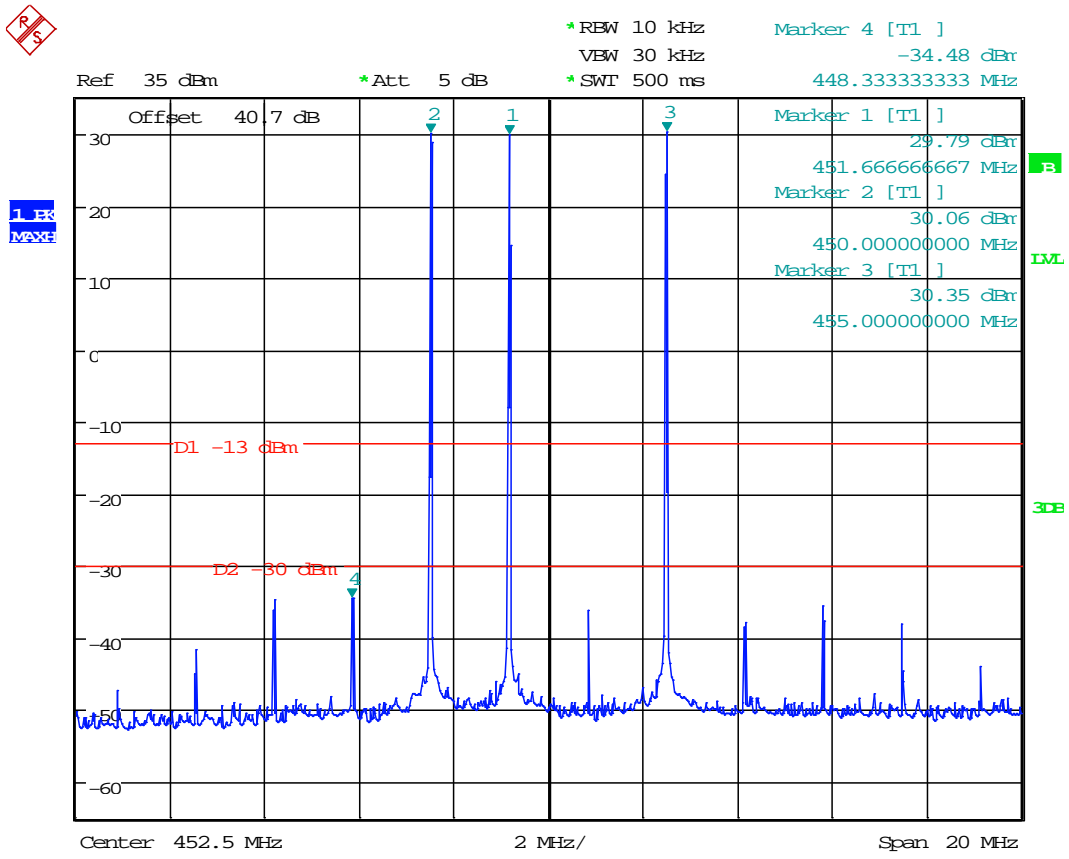

Date: 7.MAR.2014 14:12:33

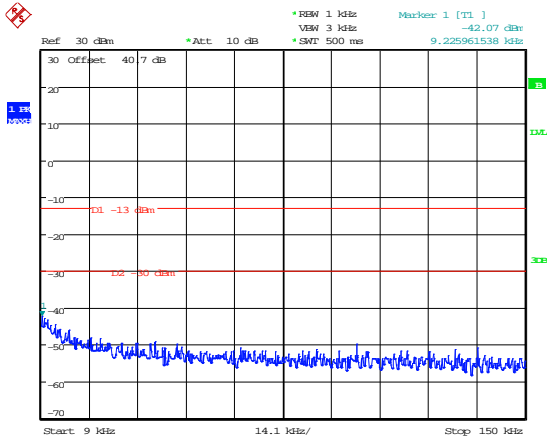

Date: 7.MAR.2014 14:25:17

9-150kHz

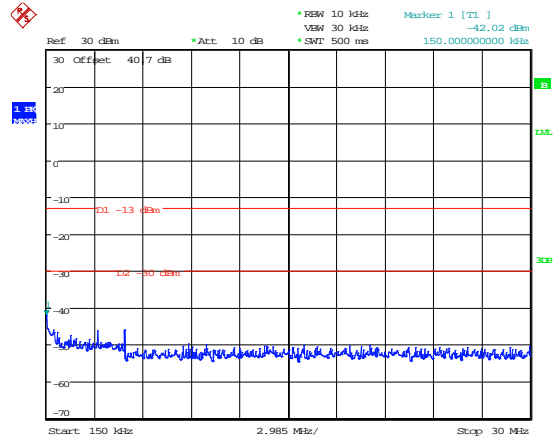

Date: 7.MAR.2014 14:25:53

150kHz – 30MHz

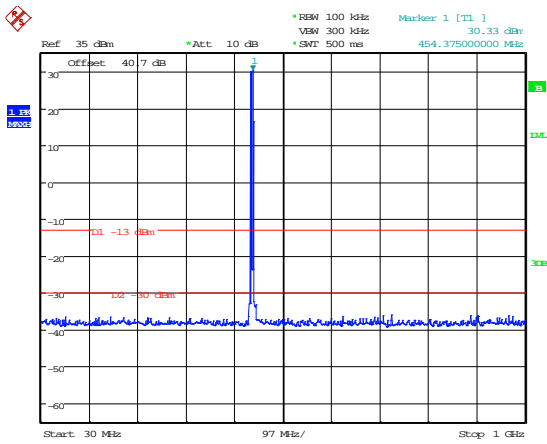

Date: 7.MAR.2014 14:24:35

30MHz – 1GHz

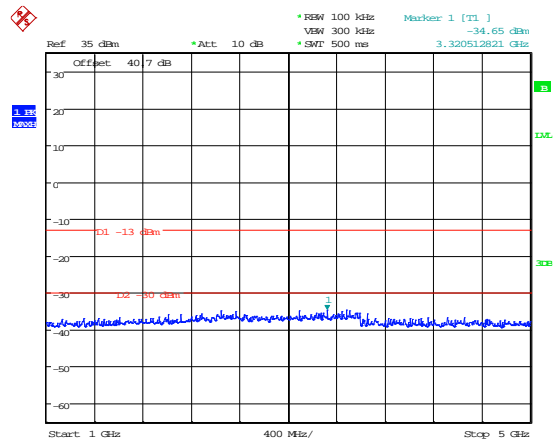

Date: 7.MAR.2014 14:24:57

1GHz – 5GHz

Upper 5 MHz band - Intermodulation close View

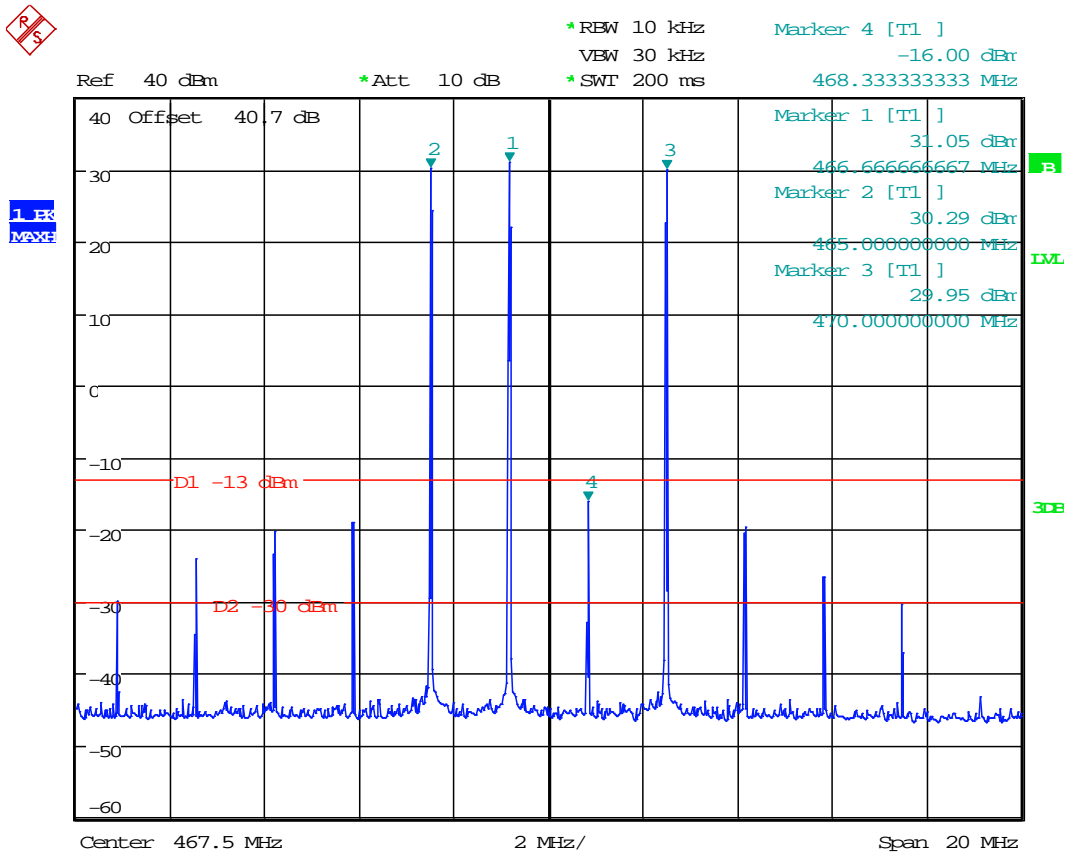

Date: 11.MAR.2014 11:19:31

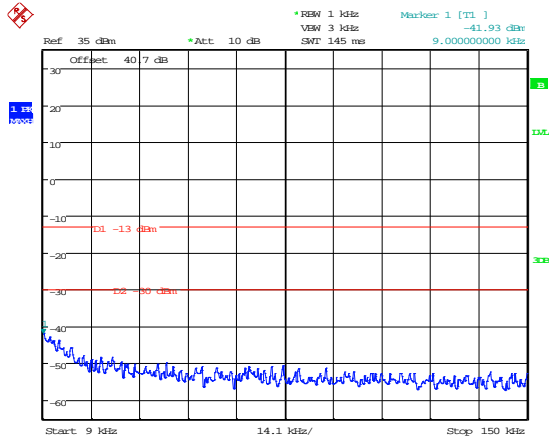

Date: 11.MAR.2014 11:20:41

9-150kHz

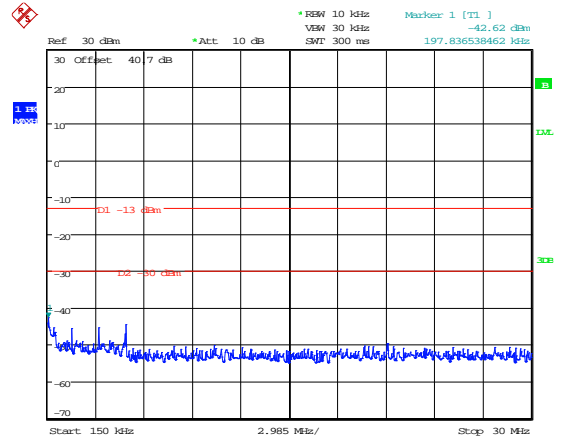

Date: 11.MAR.2014 11:20:56

150kHz – 30MHz

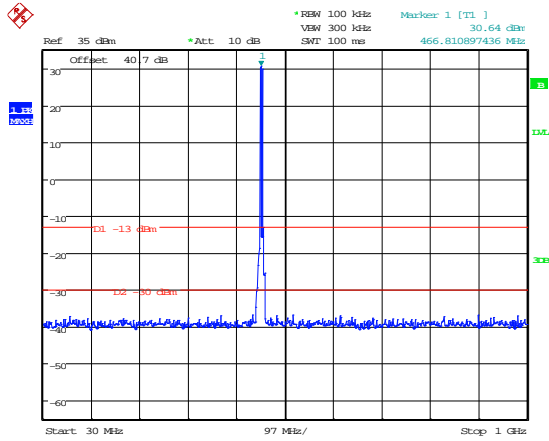

Date: 11.MAR.2014 11:20:19

30MHz – 1GHz

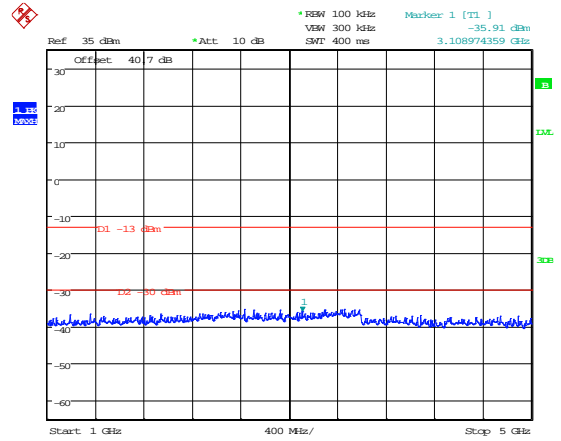

Date: 11.MAR.2014 11:20:31

1GHz – 5GHz

A3 Amplifier Modulated Channel Test

Test Details:	
Measurement standard	Part 2.1049, Part 90.219(4)(e)(iii), 90.210(c)
EUT sample number	S02
Modification state	0
SE in test environment	None
SE isolated from EUT	None
EUT set up	Refer to Appendix C

Modulation Type	Frequency Of Operation Channel (MHz)		
	450.0125	460.0000	469.9875
Analogue	10.096 kHz	10.096 kHz	10.096 kHz

As per D.3 Policies + Procedures (k) of KDB 935210 D02 Signal Boosters Certification v02 the EUT was tested at compression and 10dB into compression to show AGC operation, worst case results taken.

450.0125 Analogue Signal Generator and EUT

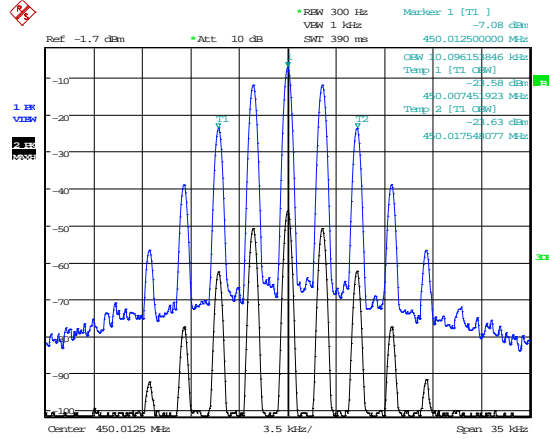

Date: 7.MAR.2014 11:56:05

460.0000 Analogue Signal Generator and EUT

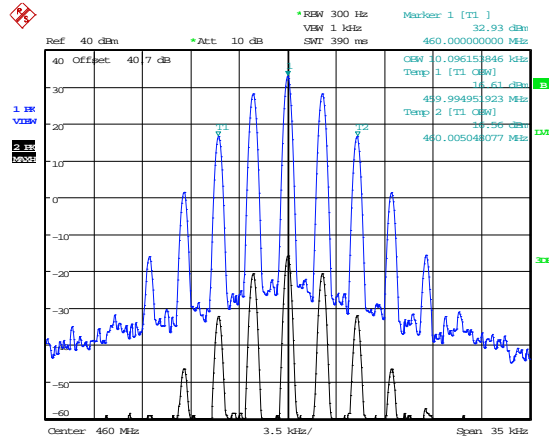

Date: 11.MAR.2014 16:07:00

469.9875 Analogue Signal Generator and EUT

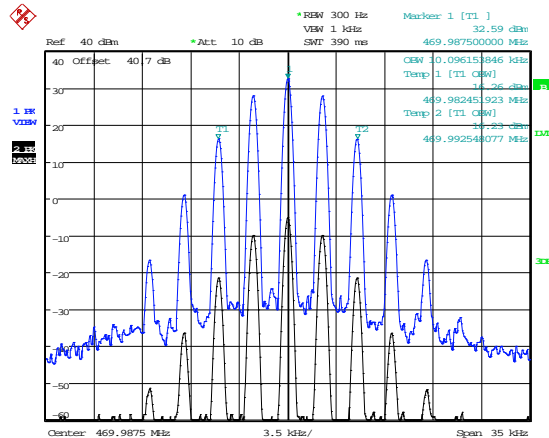

Date: 10.MAR.2014 15:27:49

The above plots depicting the output waveshape show no measurable distortion visible when compared to the input signal.

A4 Spurious Emissions at Antenna Terminals Less than 1MHz

Test Details:	
Measurement standard	Part 2.1053, 90.219(e)(3), 90.210(c)
EUT sample number	S02
Modification state	0
SE in test environment	None
SE isolated from EUT	None
EUT set up	Refer to Appendix C

Modulation Type	Bandedge	Carrier Frequency (MHz)	Max Level @ bandedge (dBm)
Analogue	Lower	450.0125	-34.11
	Upper	469.9875	-35.68

Analogue Signal – Lower Bandedge

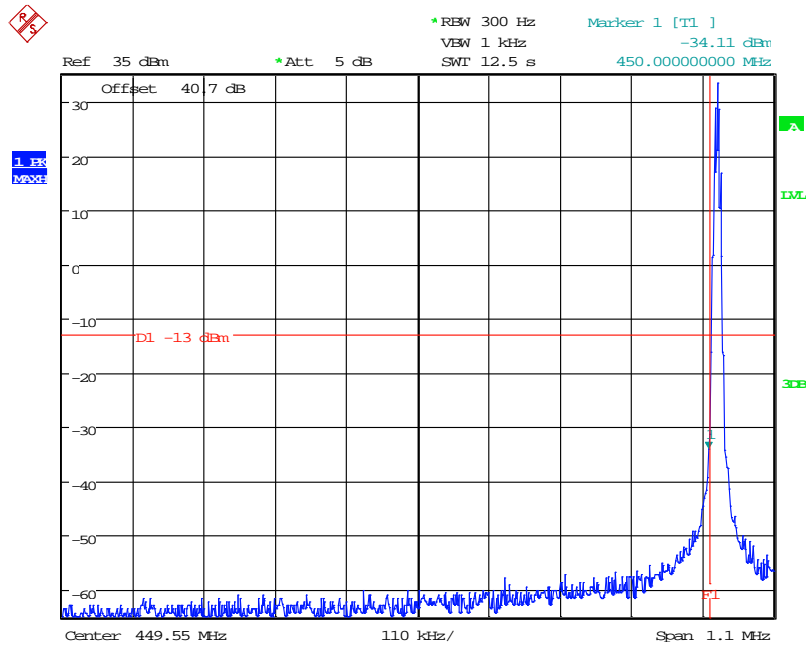

Date: 7.MAR.2014 11:51:44

Analogue Signal – Upper Bandedge

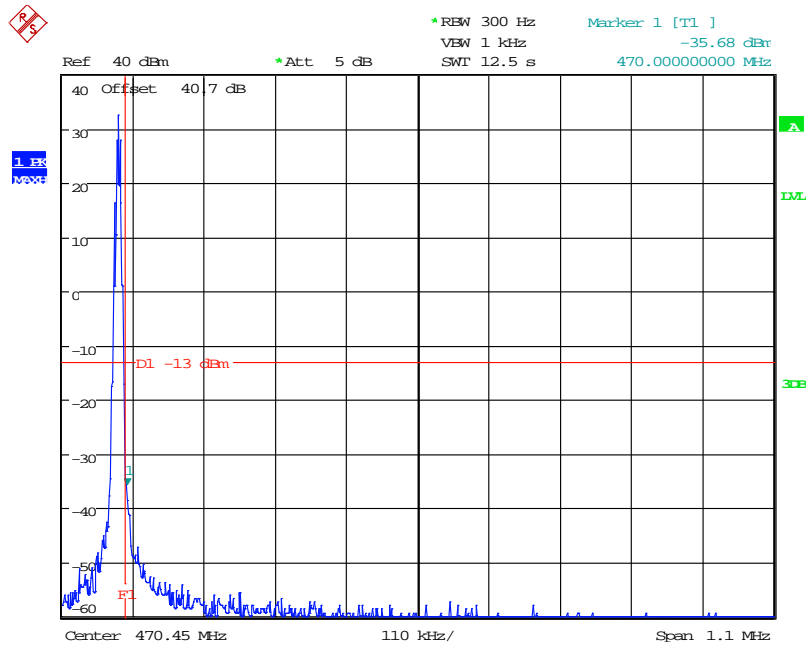

Date: 10.MAR.2014 15:26:00

A5 Spurious Emissions at Antenna Terminals Greater than 1MHz

Test Details:	
Measurement standard	Part 2.1053, 90.219(e)(3)
EUT sample number	S02
Modification state	0
SE in test environment	None
SE isolated from EUT	None
EUT set up	Refer to Appendix C

Bottom Channel

Frequency Range (MHz)	Freq. of Emission (MHz)	Measured Level (dBm)	Attenuator & Cable Losses (dB)	Spurious Emission Level (dBm)	Limit dBm
9kHz - 2GHz	No Significant Emissions Within 10 dB of the Limit				-13

Middle Channel

Frequency Range (MHz)	Freq. of Emission (MHz)	Measured Level (dBm)	Attenuator & Cable Losses (dB)	Spurious Emission Level (dBm)	Limit dBm
9kHz - 2GHz	No Significant Emissions Within 10 dB of the Limit				-13

Top channel

Frequency Range (MHz)	Freq. of Emission (MHz)	Measured Level (dBm)	Attenuator & Cable Losses (dB)	Spurious Emission Level (dBm)	Limit dBm
9kHz - 2GHz	No Significant Emissions Within 10 dB of the Limit				-13

Limit is determined by the outermost step of the emissions mask and is calculated as follows:

At least $43 + 10 \log P$ dB

$$(10 \log P_{\text{watts}}) - (43 + 10 \log (P_{\text{watts}} * 1000)) = \text{LIMIT} = -13 \text{ dBm}$$

Result

The EUT was found to comply with the limits

Spurious Emissions at Antenna Terminals Greater than 1MHz

450.0125

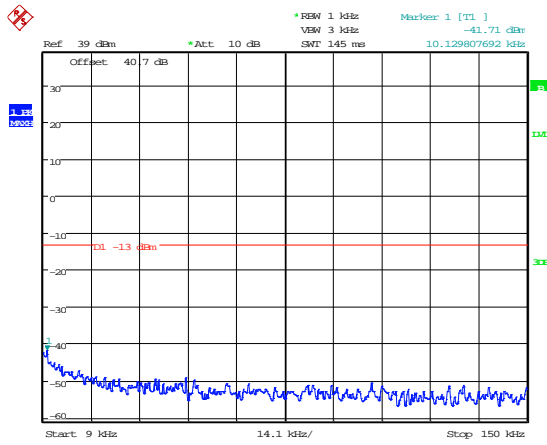

Date: 7.MAR.2014 11:53:01

9-150kHz

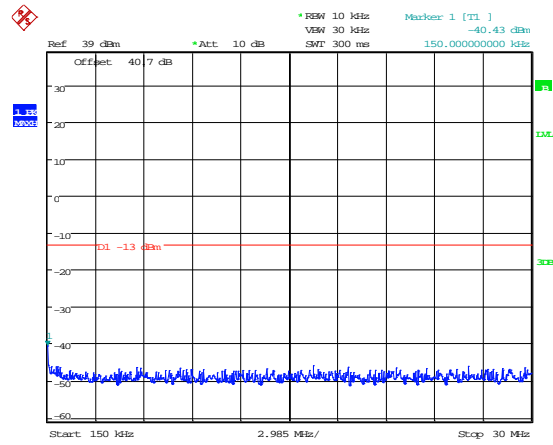

Date: 7.MAR.2014 11:53:12

150kHz – 30MHz

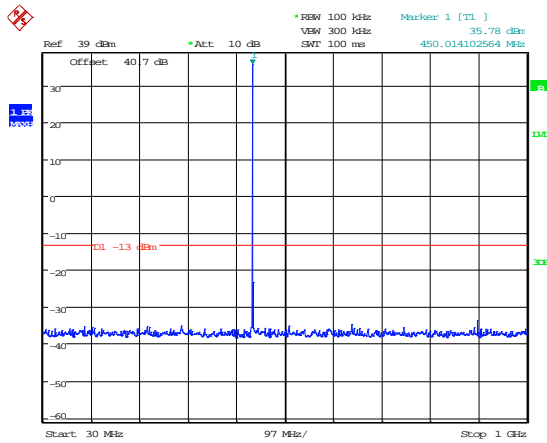

Date: 7.MAR.2014 11:52:15

30MHz – 1GHz

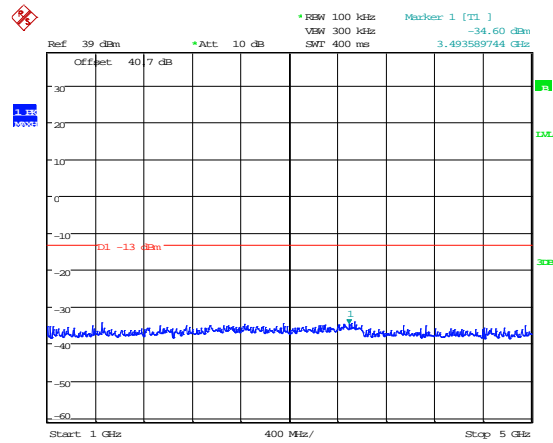

Date: 7.MAR.2014 11:52:26

1GHz – 5GHz

Spurious Emissions at Antenna Terminals Greater than 1MHz

460.0000

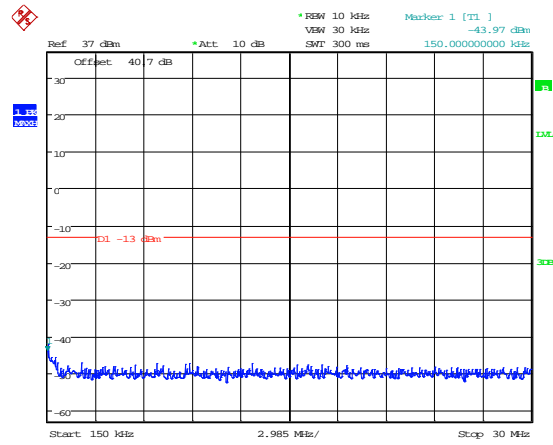
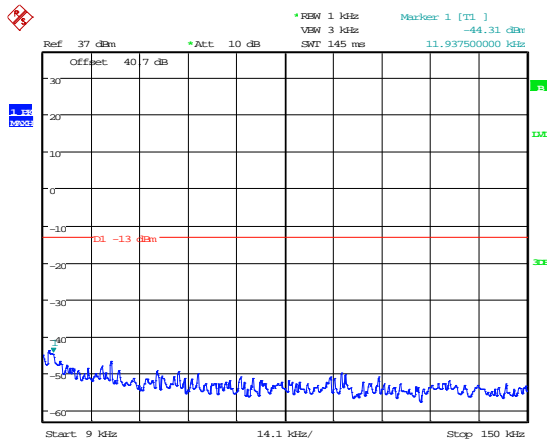

Date: 11.MAR.2014 16:09:32

Date: 11.MAR.2014 16:09:47

9-150kHz

150kHz – 30MHz

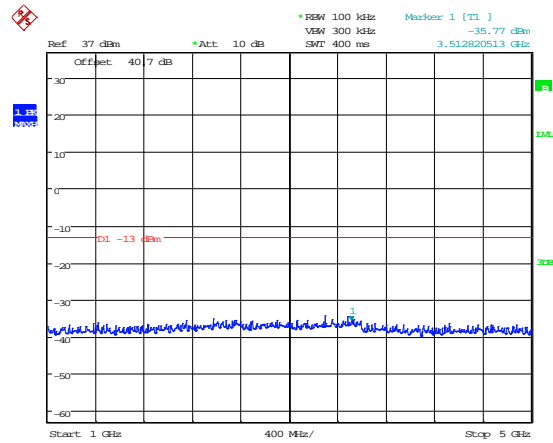
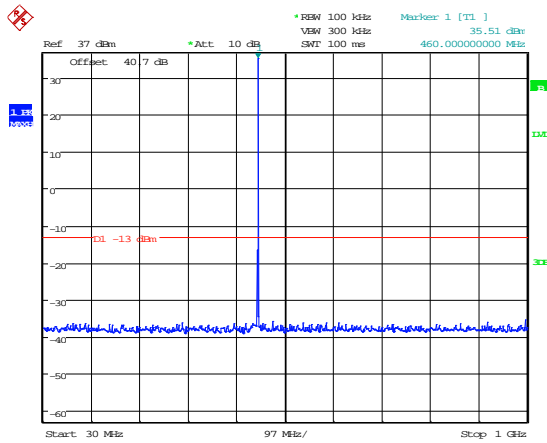

Date: 11.MAR.2014 16:09:11

Date: 11.MAR.2014 16:09:20

30MHz – 1GHz

1GHz – 5GHz

Spurious Emissions at Antenna Terminals Greater than 1MHz

469.9875

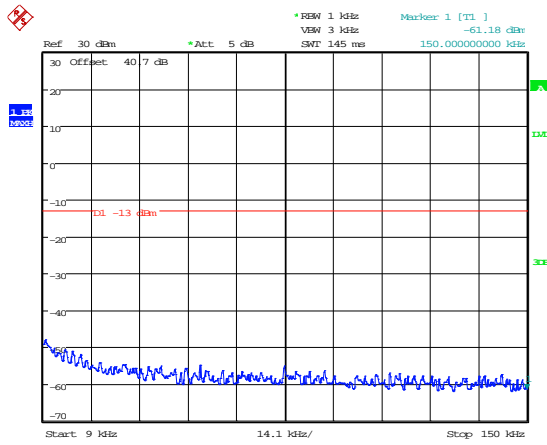

Date: 10.MAR.2014 15:22:50

9-150kHz

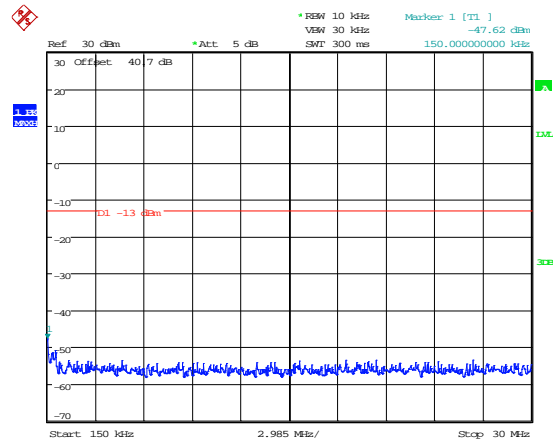

Date: 10.MAR.2014 15:23:03

150kHz – 30MHz

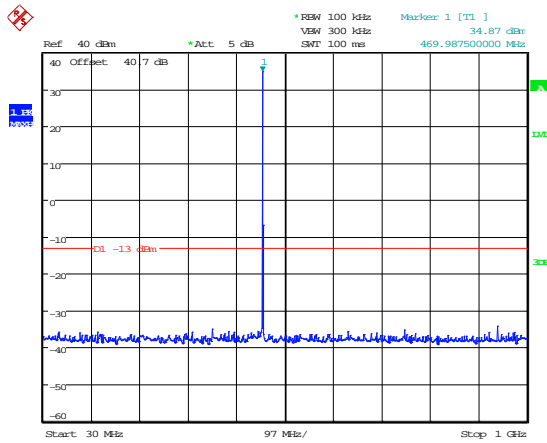

Date: 10.MAR.2014 15:22:11

30MHz – 1GHz

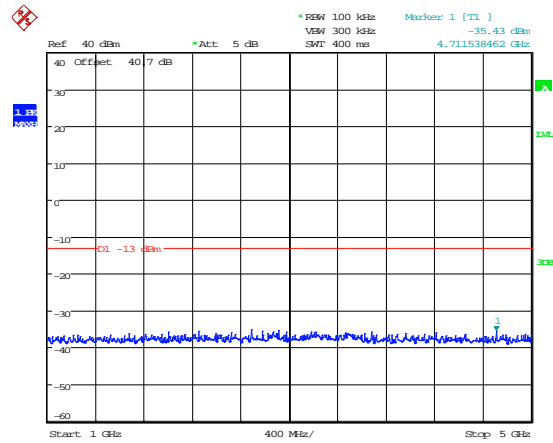

Date: 10.MAR.2014 15:22:33

1GHz – 5GHz

A6 Noise at Antenna Terminals

Test Details:	
Measurement standard	90.219(e)(2), 90.219(d)(6)
EUT sample number	S02
Modification state	0
SE in test environment	None
SE isolated from EUT	None
EUT set up	Refer to Appendix C

Compliance with these levels will be deemed satisfaction of the good engineering practice requirement. In a 10 kHz measurement bandwidth:

- (1) the ERP of noise within the signal booster passband should not exceed -43dBm ;
and
- (2) the ERP of noise on spectrum more than 1 MHz outside of the signal booster passband should not exceed -70 dBm .
- (3) The noise figure of a signal booster must not exceed 9 dB in either direction

See appendix D for declaration of good engineering practice.

IN BAND AMPLIFIER NOISE – Lower 5 MHz Band

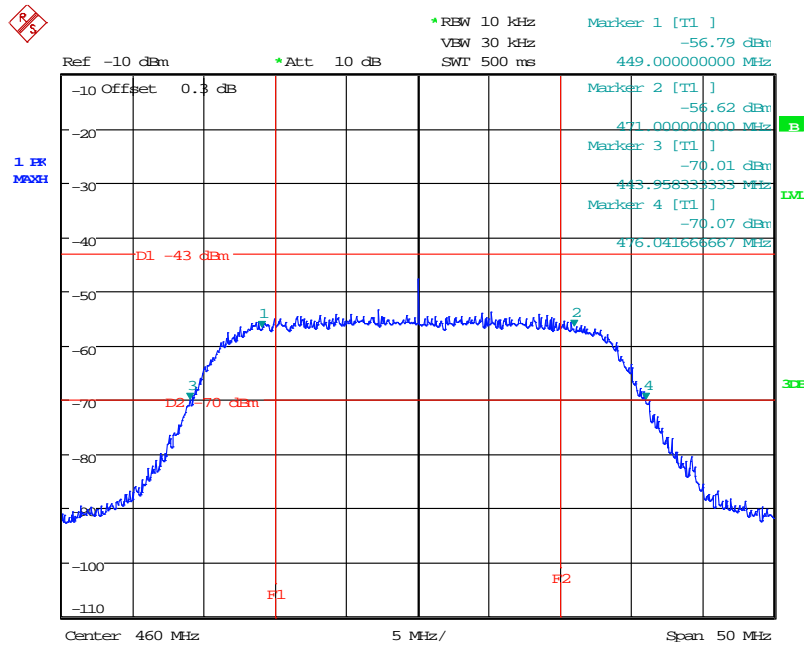

Date: 7.MAR.2014 12:01:40

IN BAND AMPLIFIER NOISE – Upper 5 MHz Band

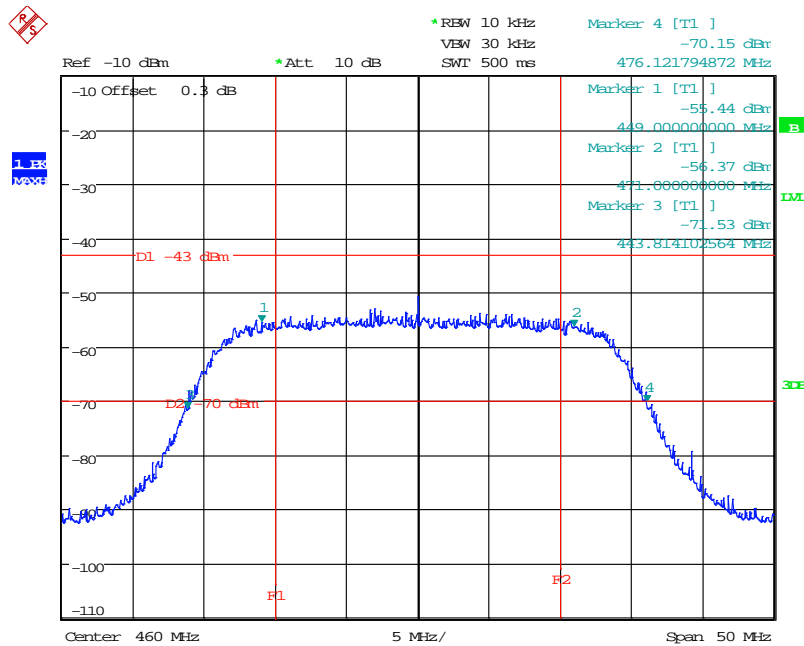

Date: 11.MAR.2014 10:58:11

Signal booster noise figure

Test equipment set up:-

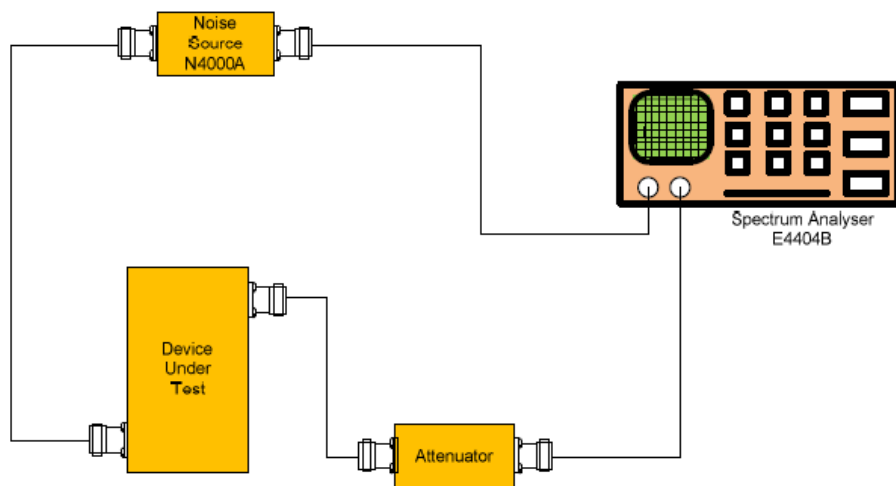

Result

Plots for noise figure, taken with the 18MHz filter applied at maximum gain with 70dB external attenuators in the test set up

Frequency (MHz)	Noise Figure dB
450.0125	5.0563
469.9875	5.1087

General notes about measurement setup:

- 1) The spectrum analyser has the noise figure measurement personality enabled.

Noise Figure – 450.0125 MHz

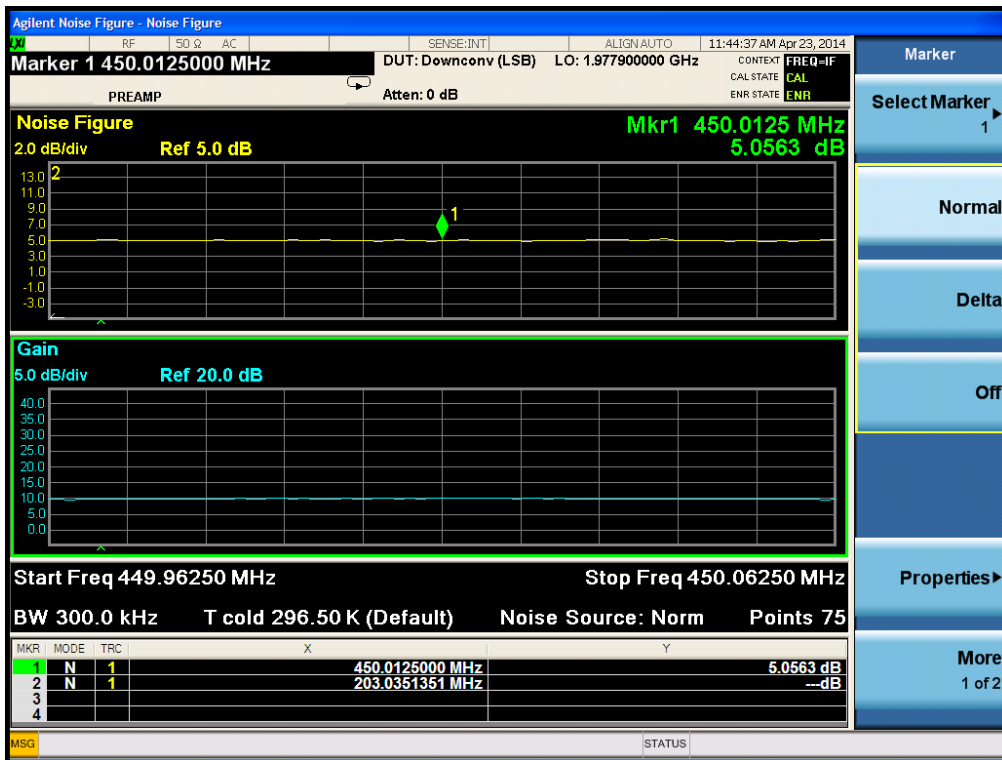

Noise Figure – 469.9875 MHz

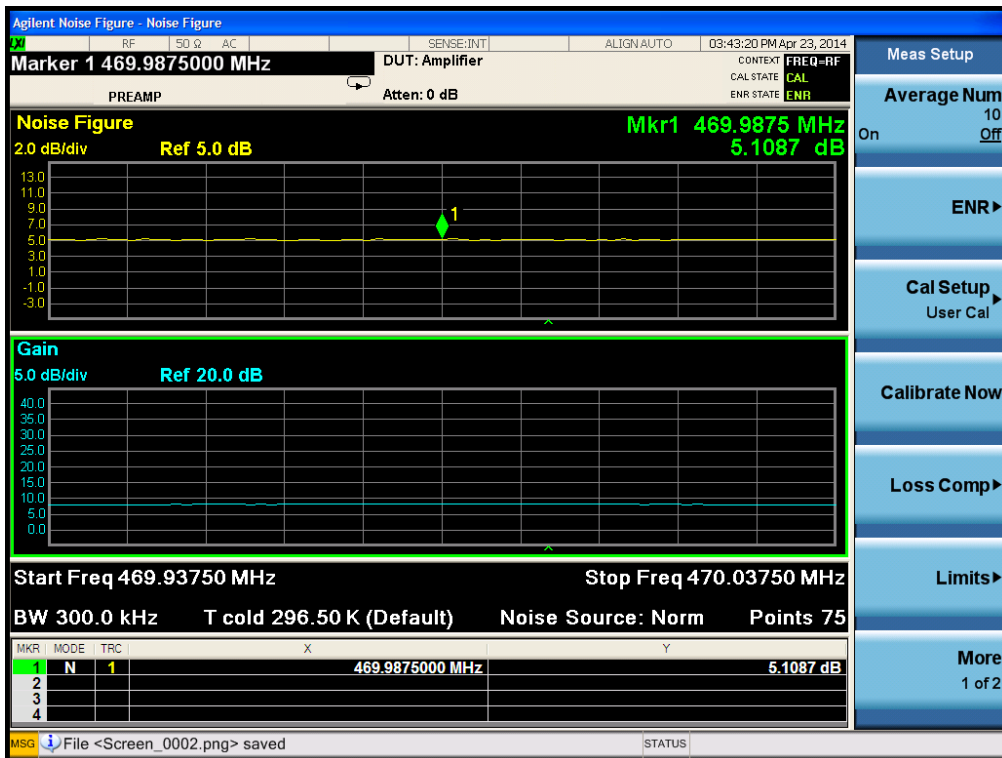

A7 Radiated Electric Field Emissions

Preliminary scans were performed using a peak detector with the RBW = 100kHz. The radiated electric field emission test applies to all spurious and harmonic emissions. The EUT was set to transmit as required.

The following test site was used for final measurements as specified by the standard tested to:

3m open area test site : 3m alternative test site :

The effect of the EUT set-up on the measurements is summarised in note (c) below.

Test Details:	
Measurement standard	Title 47 of the CFR: Part 2.1053, RSS-131 Section 4.3.2
Frequency range	30 MHz – 5 GHz
EUT sample number	S02
Modification state	0
SE in test environment	None
SE isolated from EUT	None
EUT set up	Refer to Appendix C

Bottom Frequency

FREQUENCY RANGE	FREQ. (MHz)	ERP/EIRP (dBm)	LIMIT (dBm)
30MHz - 5GHz	No Significant Emissions Within 10 dB of the Limit		-13

Middle Frequency

FREQUENCY RANGE	FREQ. (MHz)	ERP/EIRP (dBm)	LIMIT (dBm)
30MHz - 5GHz	No Significant Emissions Within 10 dB of the Limit		-13

Top Frequency

FREQUENCY RANGE	FREQ. (MHz)	ERP/EIRP (dBm)	LIMIT (dBm)
30MHz - 5GHz	No Significant Emissions Within 10 dB of the Limit		-13

Result

The EUT was found to comply with the limits

Notes:

1. Emissions Checked up to 10 times Fc.
2. The unit was mounted on a turntable and rotated through 360⁰ and in 3 orthogonal planes to find the worst case emission.
3. For Frequencies below 1 GHz, RBW = 120 kHz, testing was performed with CISPR16 compliant test receiver with QP detector. Above 1 GHz tests were performed using a spectrum analyser using the following settings:

Peak Detector RBW = 1MHz; VBW = ≥RBW

4. Limit is determined as the outermost step of the emissions mask and is calculated as follows.

At least 43 + 10 log P dB

$$(10\log P_{\text{watts}}) - (43 + 10\log (P_{\text{watts}} * 1000)) = \text{LIMIT } = -13 \text{ dBm}$$

The upper and lower frequency of the measurement range was decided according to 47 CFR Part 2.1057.

- (a) Where results have been measured at one distance, and a signal level displayed at another, the results have been extrapolated using the following formula:

$$\text{Extrapolation (dB)} = 20 \log_{10} \left(\frac{\text{measurement distance}}{\text{specification distance}} \right)$$

- (b) The levels may have been rounded for display purposes.
- (c) The following table summarises the effect of the EUT operating mode, internal configuration and arrangement of cables / samples on the measured emission levels :

	See (i)	See (ii)	See (iii)	See (iv)
Effect of EUT operating mode on emission levels	✓			
Effect of EUT internal configuration on emission levels	✓			
Effect of Position of EUT cables & samples on emission levels	✓			
(i) Parameter defined by standard and / or single possible, refer to Appendix D (ii) Parameter defined by client and / or single possible, refer to Appendix D (iii) Parameter had a negligible effect on emission levels, refer to Appendix D (iv) Worst case determined by initial measurement, refer to Appendix D				

Radiated Electric Field Emissions

450.0125

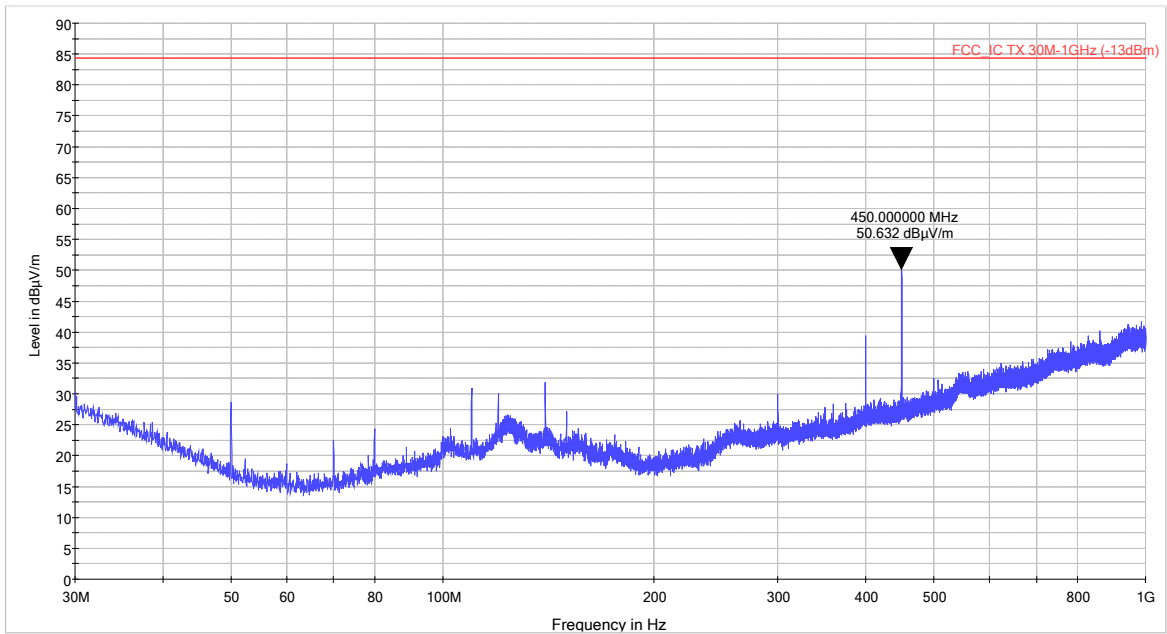

30MHz – 1GHz

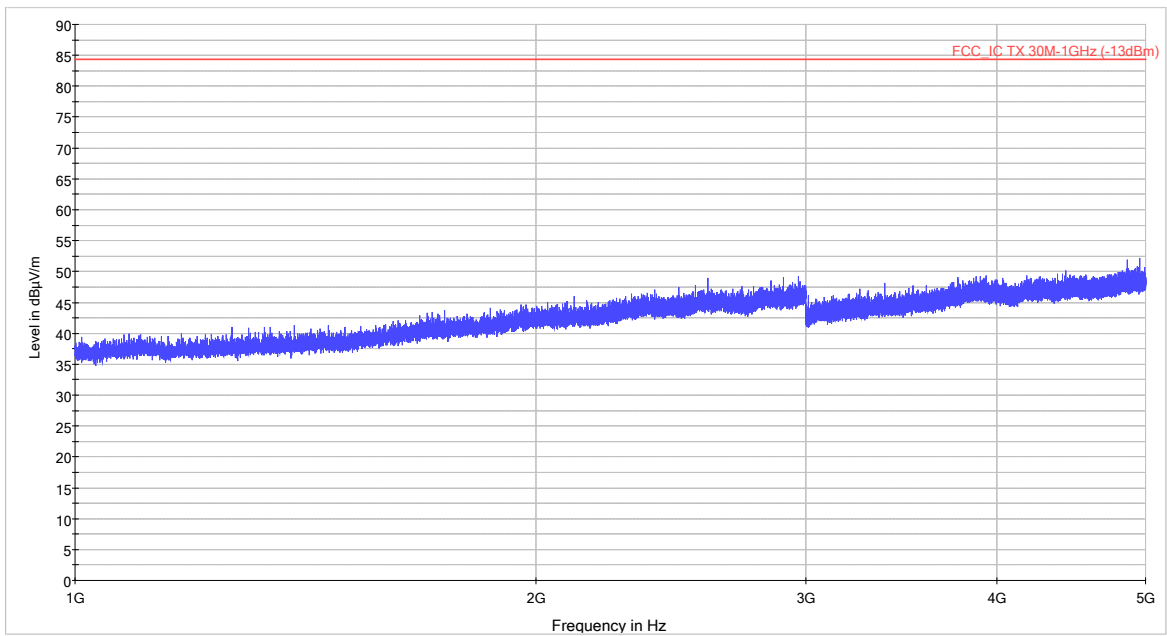

1GHz – 5GHz

Radiated Electric Field Emissions

460.0000

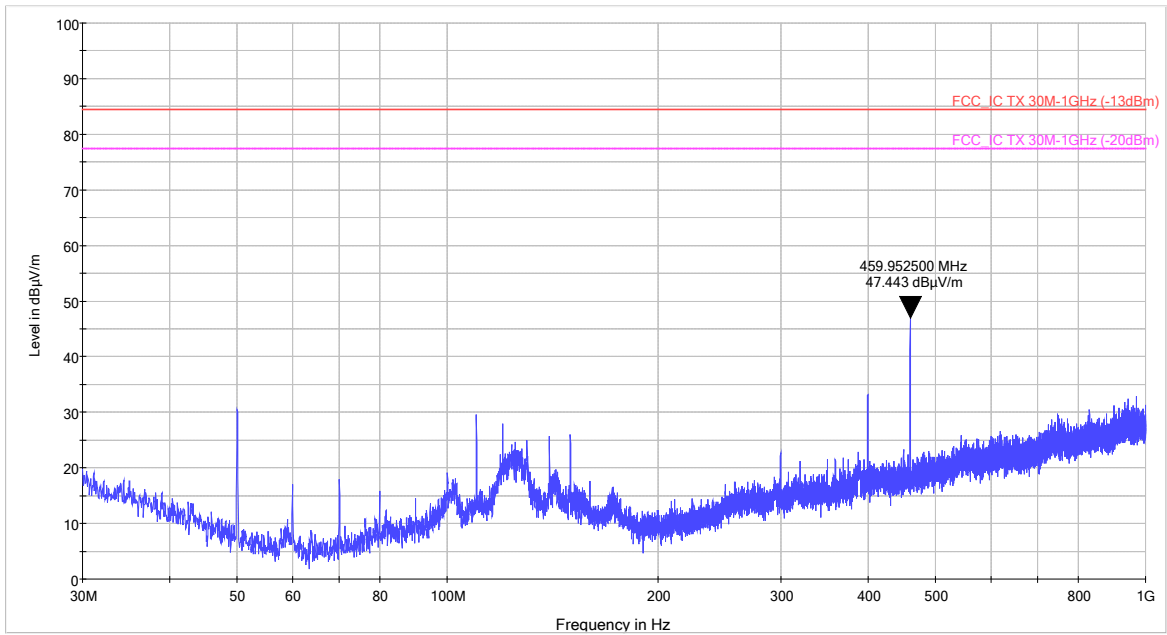

30MHz – 1GHz

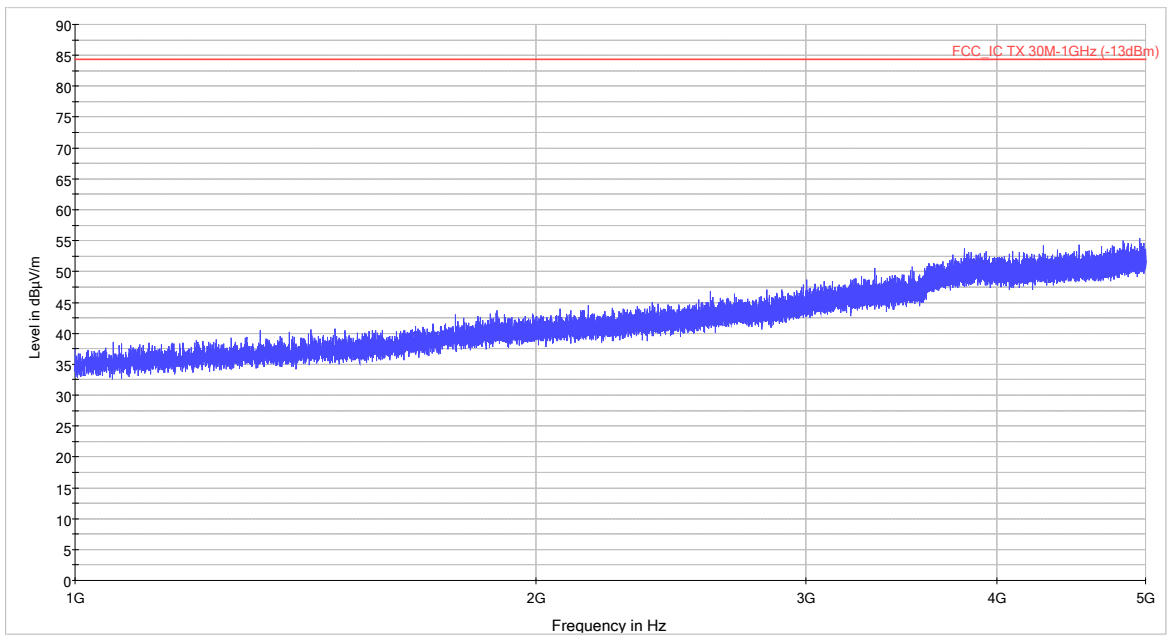

1GHz – 5GHz

Radiated Electric Field Emissions

469.9875

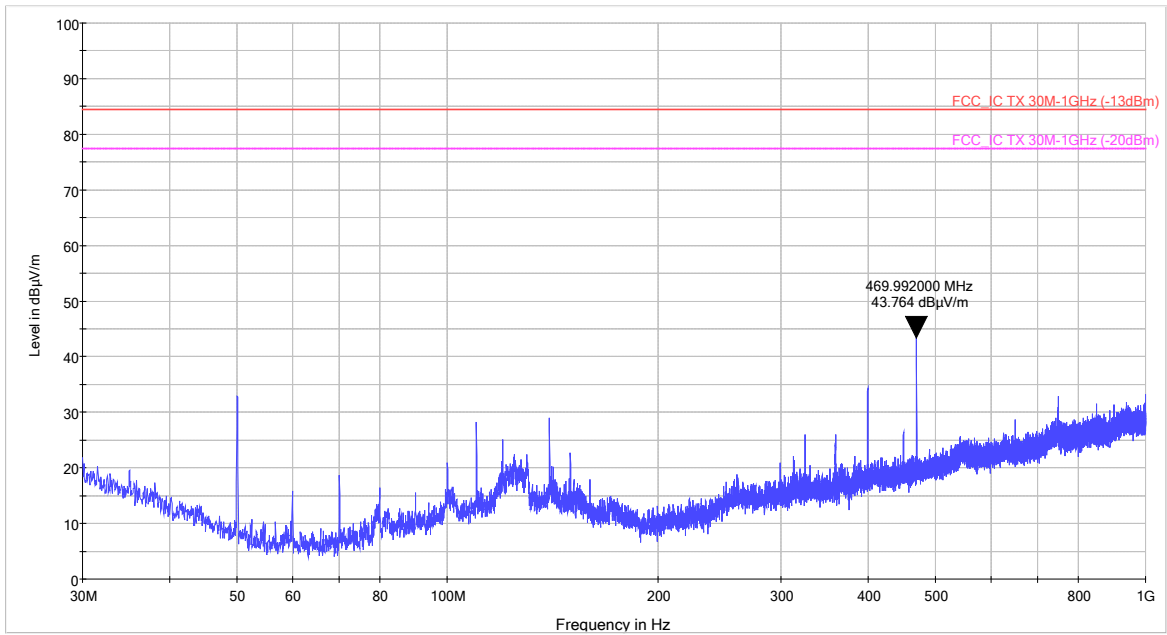

30MHz – 1GHz

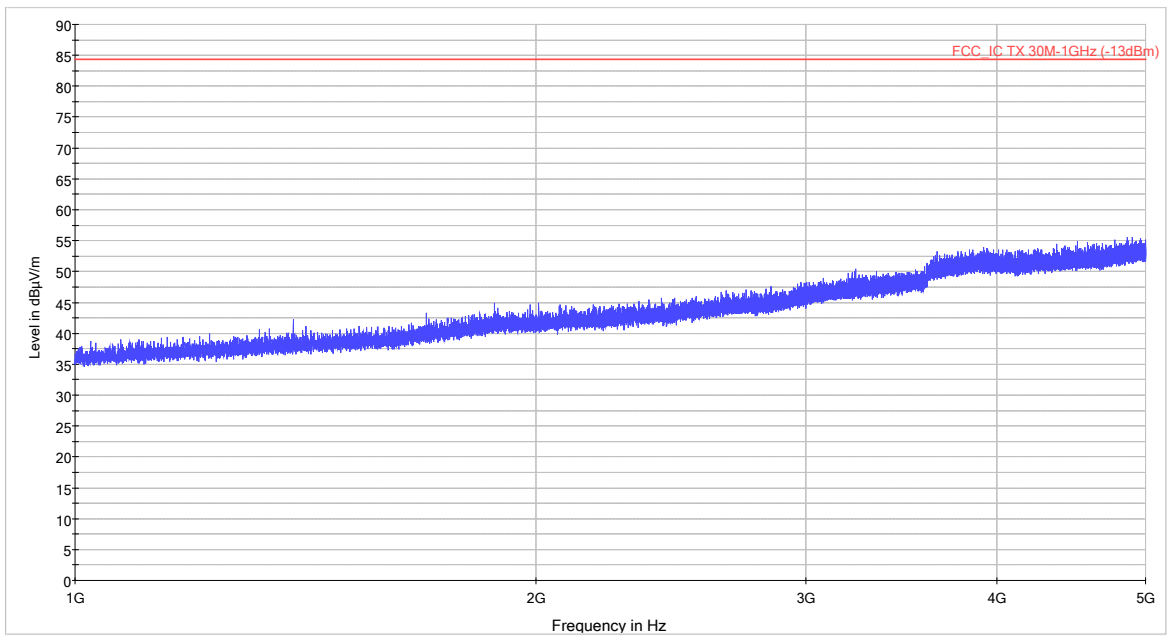

1GHz – 5GHz

A8 Passband Gain & Bandwidth

Test Details:	
Measurement standards	RSS-131 Section 4.2
	D.3 Policies + Procedures (k) of KDB 935210 D02 Signal Boosters Certification v02
EUT sample number	S02
Modification state	0
SE in test environment	None
SE isolated from EUT	None
EUT set up	Refer to Appendix C

Frequency MHz	Fl MHz	Fh MHz	20 dB Bandwidth
450.00625	449.982211538	450.030288462	48.077 kHz
469.99375	469.964903846	470.022596154	57.692 kHz
450 - 470	449.982211538	470.022596154	20.040 MHz

1. See below for plots showing passband gain & bandwidth

With the aid of a CW Swept signal generator and spectrum analyser, the bandwidth and frequency response of the open channel (i.e. at the point where the gain has fallen by 20 dB) is measured. This measurement shows the gain-versus-frequency response of the open channel from the midband frequency f_0 of the channel up to at least $f_0 + 250\%$ of the 20 dB bandwidth.

Lower 5 MHz band – 450.00625 MHz

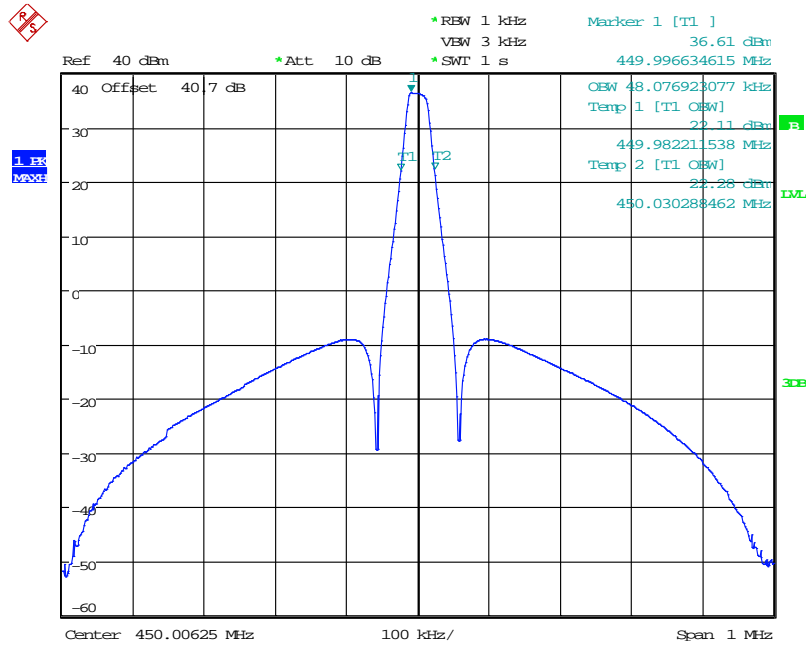

Date: 10.MAR.2014 09:02:41

Upper 5 MHz band – 469.99375 MHz

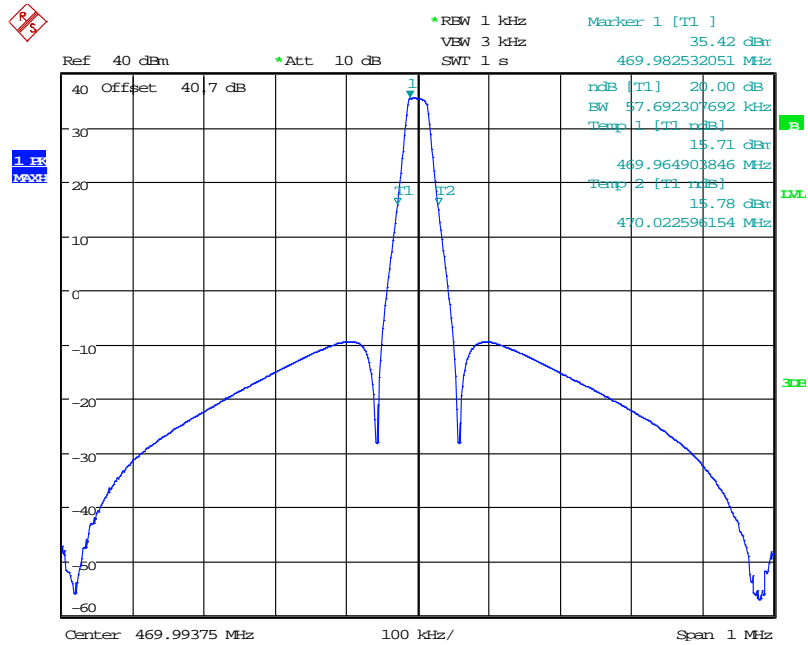

Date: 11.MAR.2014 10:01:26

Appendix B:**Downlink Formal Emission Test Results**

Abbreviations used in the tables in this appendix:

Spec	: Specification	ALSR	: Absorber Lined Screened Room
Mod	: Modification	OATS	: Open Area Test Site
EUT	: Equipment Under Test	ATS	: Alternative Test Site
SE	: Support Equipment	Ref	: Reference
L	: Live Power Line	Freq	: Frequency
N	: Neutral Power Line	MD	: Measurement Distance
E	: Earth Power Line	SD	: Spec Distance
Pk	: Peak Detector	Pol	: Polarisation
QP	: Quasi-Peak Detector	H	: Horizontal Polarisation
Av	: Average Detector	V	: Vertical Polarisation
CDN	: Coupling & decoupling network		

B1 RF Gain and Output Power

Test Details:	
Measurement standard	Part 2.1046, Part 90.219(d)(3),RSS-131 Section 4.3
EUT sample number	S02
Modification state	0
SE in test environment	None
SE isolated from EUT	None
EUT set up	Refer to Appendix C

Frequency MHz	Signal Generator input level dBm	Input Cable Loss dB	Level at Spectrum Analyser dBm	Output Cable & Attenuator loss dB	Gain dB	Conducted Output Power dBm	Gain after 10dB input level increase dB
450.0125	-54.40	0.30	-4.45	40.7	90.95	36.25	80.75
460.0000	-55.30	0.30	-3.94	40.7	92.36	36.76	81.37
469.9875	-53.70	0.30	-4.67	40.7	90.03	36.03	79.06

Notes: 1.The signal generator input was increased by 10dBs and the level of the output signal remeasured.

As per D.3 Policies + Procedures (k) of KDB 935210 D02 Signal Boosters Certification v02 the EUT was tested at compression and 10dB into compression to show AGC operation

Lower 5 MHz Band					
Frequency	Frequency (MHz)	P _o	Level at Spectrum Analyser (dBm)	Output Cable & Attenuator loss (dB)	Power At Output Point (dBm)
f ₁	451.750	P _{o1}	-7.75	40.7	32.95
f ₂	453.250	P _{o2}	-7.79	40.7	32.91
f ₃	451.000	P _{o3}	-68.23	40.7	-27.53
f ₄	454.000	P _{o4}	-71.31	40.7	-30.61

$$P_{\text{mean}} = P_{o1} + 3\text{dB}$$

P _{o1} (dBm)	P _{mean}	P _{mean} (dBm)
32.95	P _{o1} + 3dB	35.95

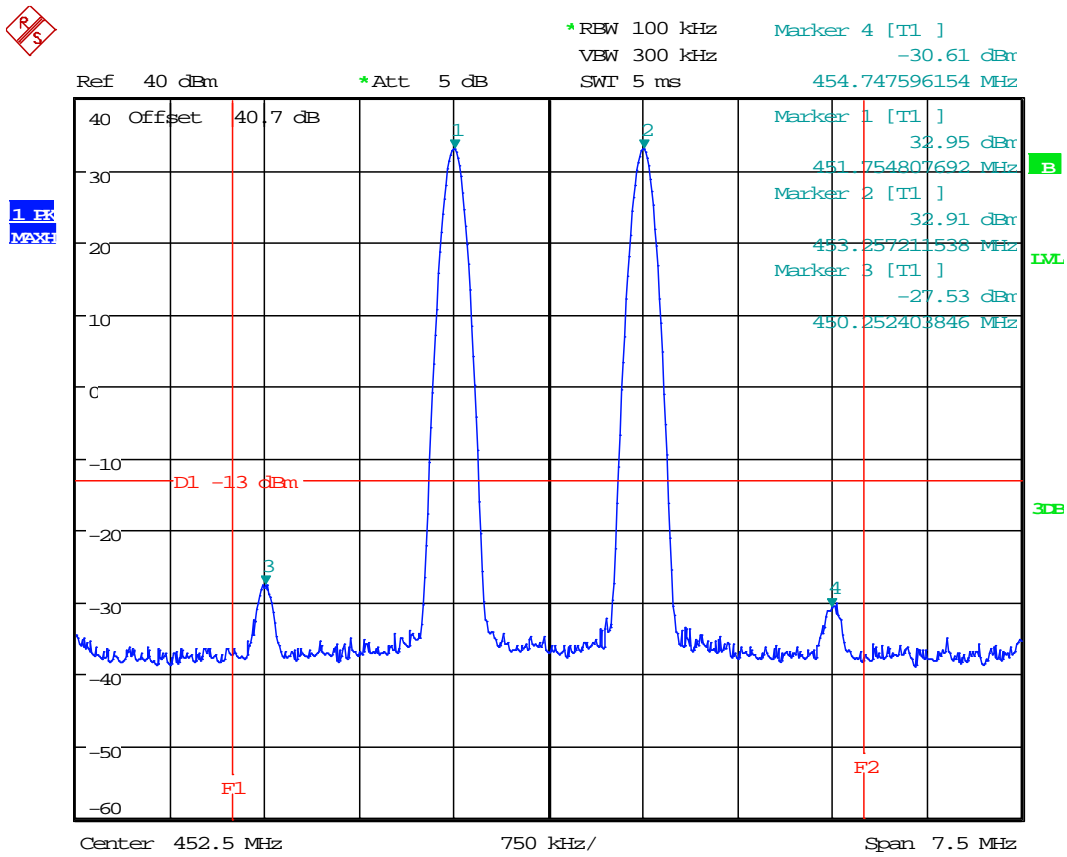

Date: 7.MAR.2014 13:56:00

Middle 5 MHz Band					
Frequency	Frequency (MHz)	P _o	Level at Spectrum Analyser (dBm)	Output Cable & Attenuator loss (dB)	Power At Output Point (dBm)
f ₁	459.250	P _{o1}	-8.88	40.7	31.82
f ₂	460.750	P _{o2}	-7.05	40.7	33.65
f ₃	458.500	P _{o3}	-69.5	40.7	-28.80
f ₄	461.500	P _{o4}	-69.9	40.7	-29.20

$$P_{\text{mean}} = P_{o1} + 3\text{dB}$$

P _{o1} (dBm)	P _{mean}	P _{mean} (dBm)
33.65	P _{o1} + 3dB	36.65

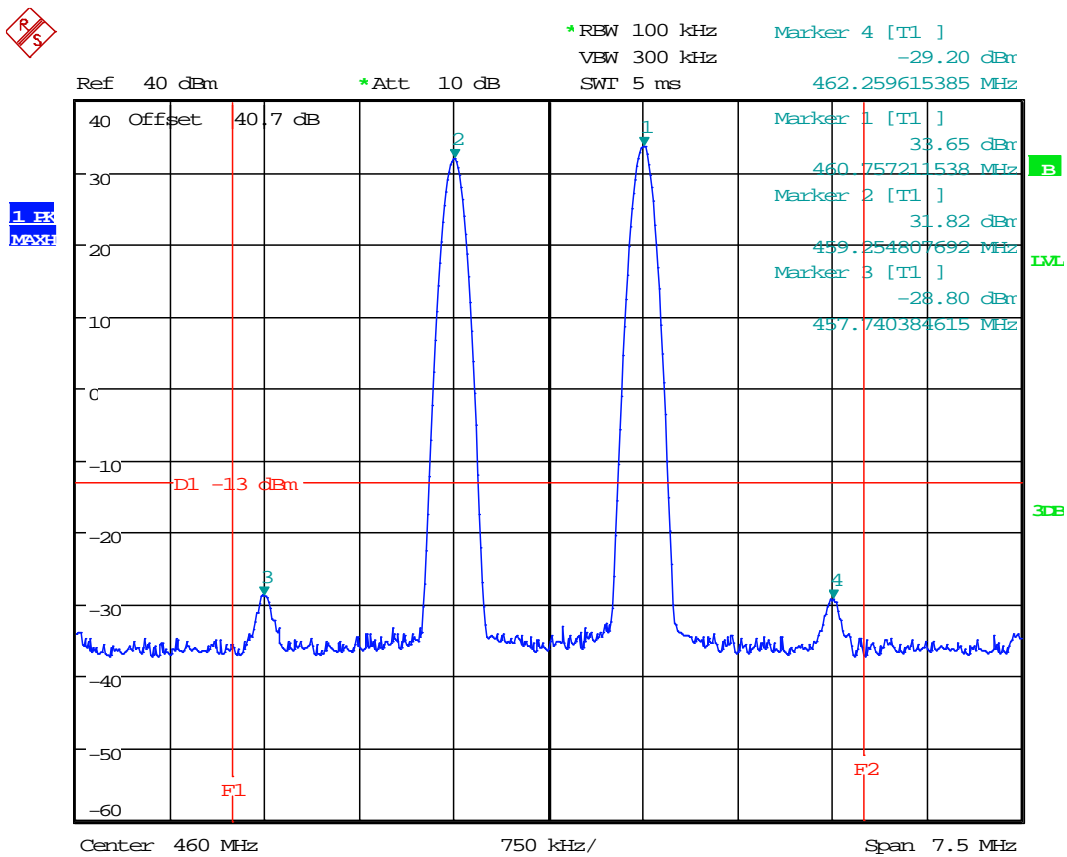

Date: 11.MAR.2014 16:01:31

Upper 5 MHz Band					
Frequency	Frequency (MHz)	P _o	Level at Spectrum Analyser (dBm)	Output Cable & Attenuator loss (dB)	Power At Output Point (dBm)
f ₁	466.750	P _{o1}	-8.11	40.7	32.59
f ₂	468.250	P _{o2}	-7.57	40.7	33.13
f ₃	466.000	P _{o3}	-67.08	40.7	-26.38
f ₄	469.000	P _{o4}	-67.43	40.7	-26.73

$$P_{\text{mean}} = P_{o1} + 3\text{dB}$$

P _{o1} (dBm)	P _{mean}	P _{mean} (dBm)
33.13	P _{o1} + 3dB	36.13

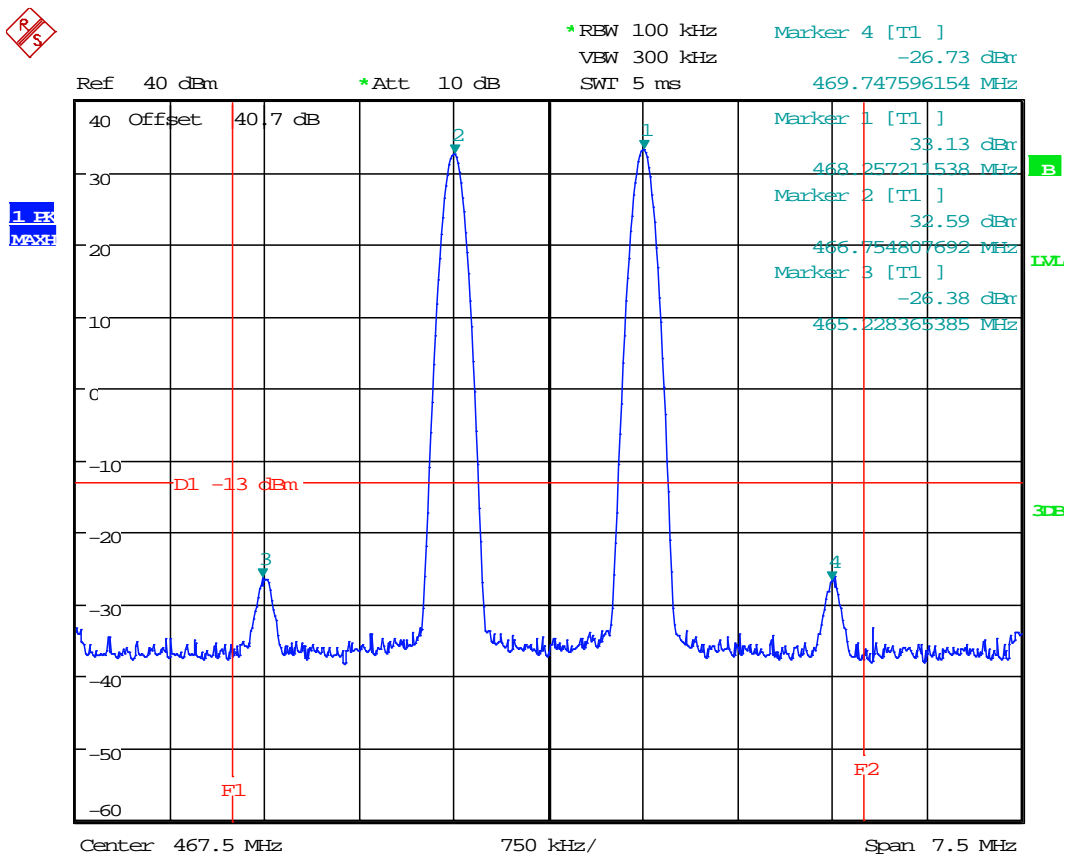

Date: 11.MAR.2014 11:30:28

B2 Amplifier Intermodulation Spurious Emissions

Test Details:	
Measurement standard	Part 2.1053, 90.219(d)(6)
EUT sample number	S02
Modification state	0
SE in test environment	None
SE isolated from EUT	None
EUT set up	Refer to Appendix C

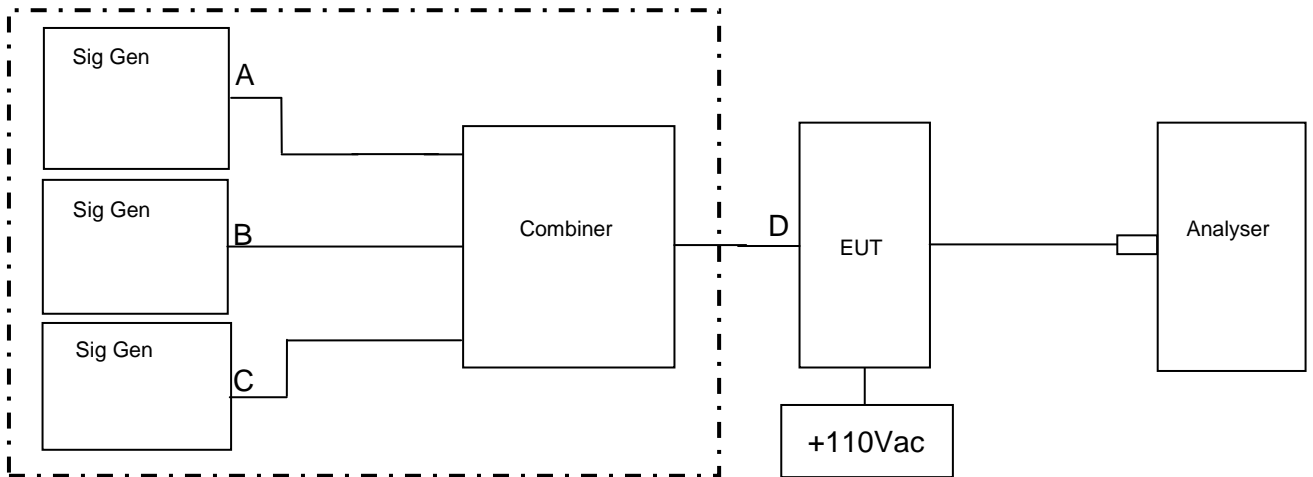

Signal Generator B was varied in frequency to check if intermodulation products were produced.

RF Input Frequency (MHz)			Highest Intermodulation Product Level (dBm)	Limit (dBm)
Lower 5 MHz Band				
450.0125	451.670	454.9875	-29.49 dBm @ 446.702 MHz	-13
Upper 5 MHz Band				
465.0125	466.666	469.9875	-28.58 dBm @ 461.698 MHz	-13

Sweep data is shown on the next page:

Results

The EUT was found to comply with the limits

See plots below

As per D.3 Policies + Procedures (k) of KDB 935210 D02 Signal Boosters Certification v02 the EUT was tested at compression and 10dB into compression to show AGC operation, worst case results taken.

Lower 5 MHz band - Intermodulation close View

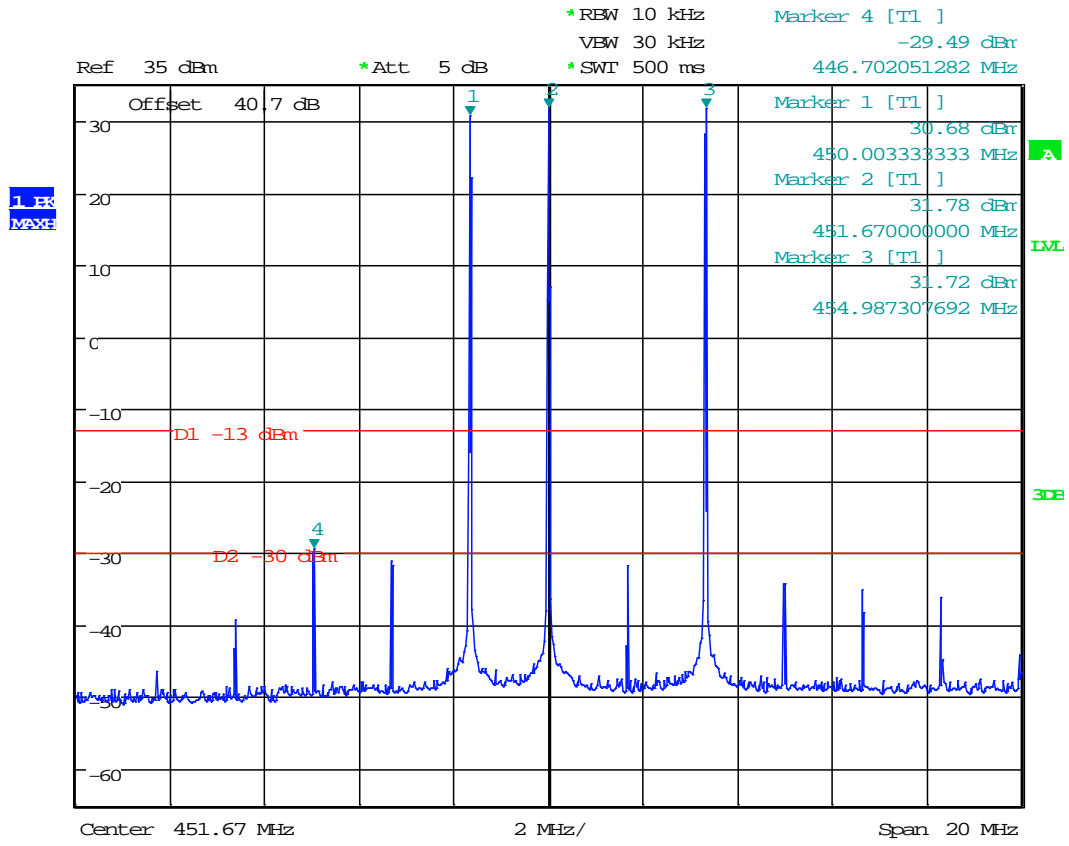

Date: 12.MAR.2014 15:40:50

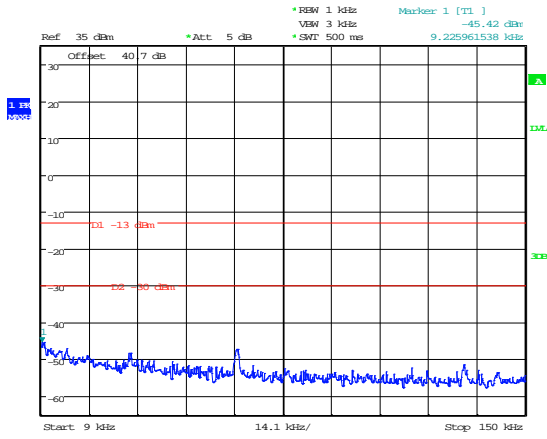

Date: 12.MAR.2014 15:42:30

9-150kHz

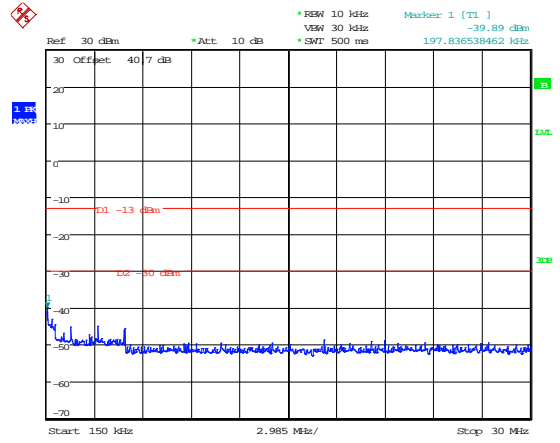

Date: 12.MAR.2014 15:13:18

150kHz – 30MHz

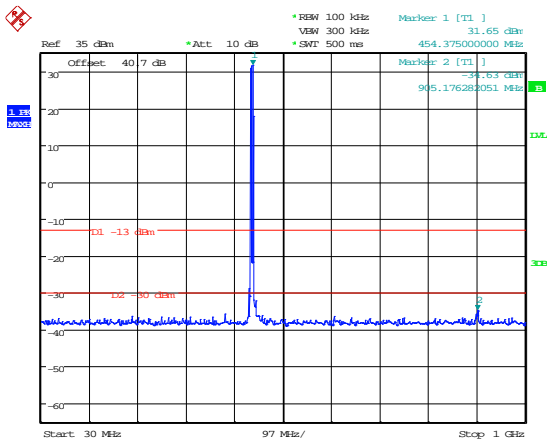

Date: 12.MAR.2014 15:15:39

30MHz – 1GHz

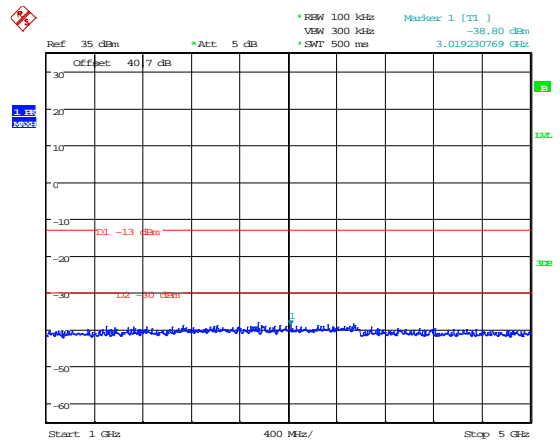

Date: 12.MAR.2014 15:18:21

1GHz – 5GHz

Upper 5 MHz band - Intermodulation close View

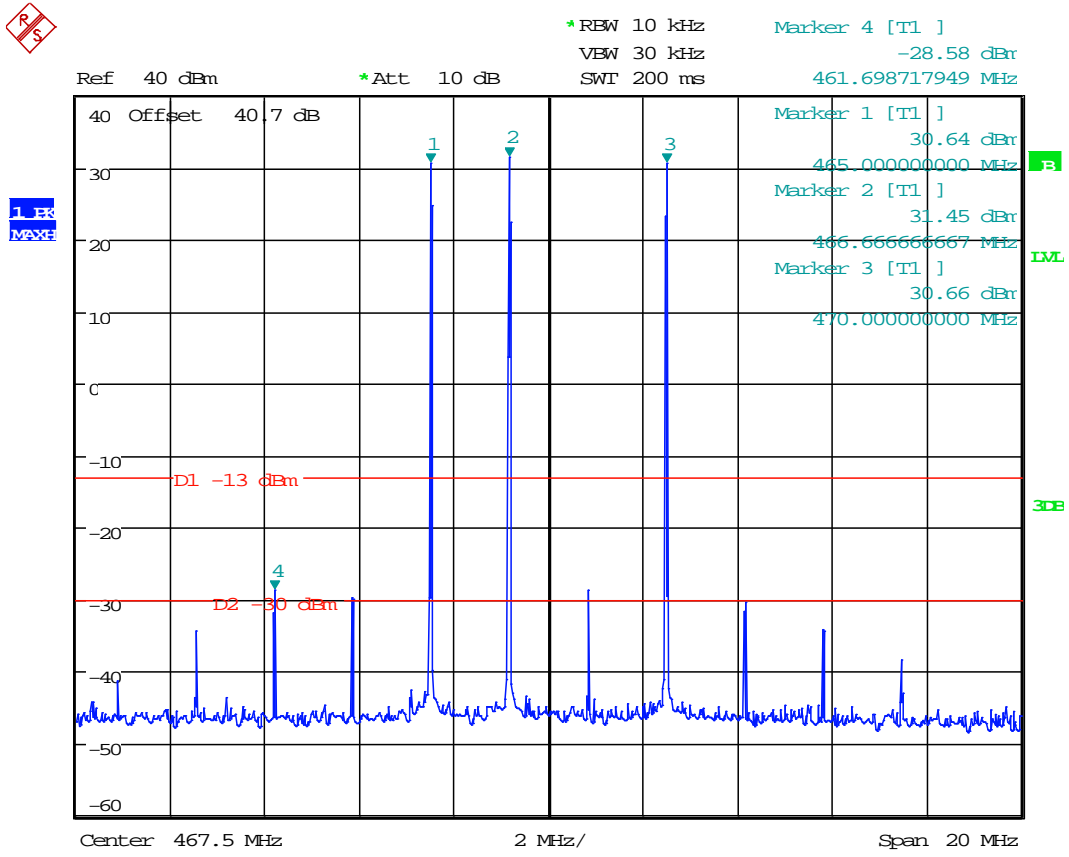

Date: 11.MAR.2014 11:09:23

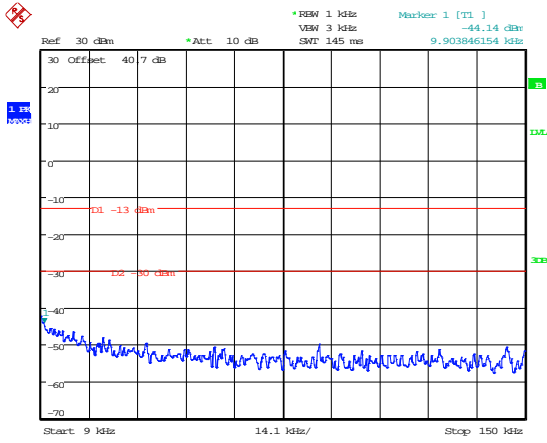

Date: 11.MAR.2014 11:12:32

9-150kHz

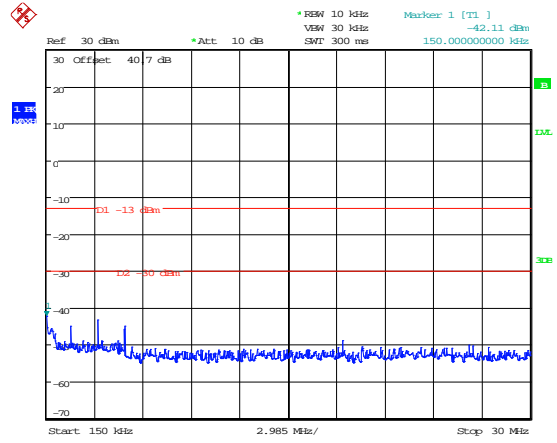

Date: 11.MAR.2014 11:13:22

150kHz – 30MHz

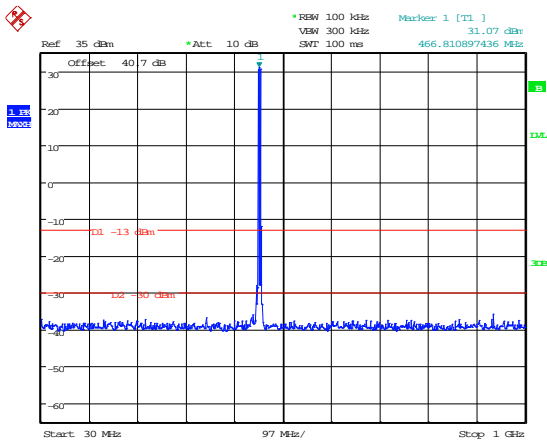

Date: 11.MAR.2014 11:11:54

30MHz – 1GHz

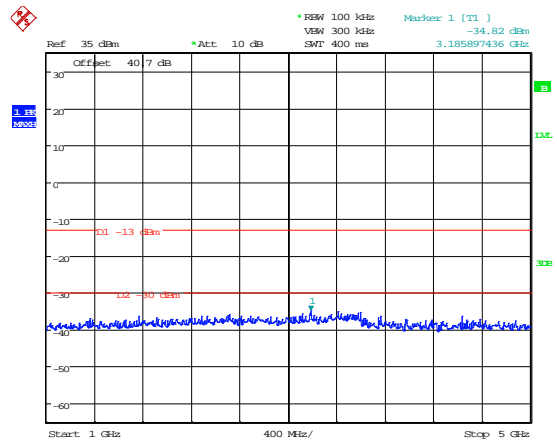

Date: 11.MAR.2014 11:12:06

1GHz – 5GHz

B3 Amplifier Modulated Channel Test

Test Details:	
Measurement standard	Part 2.1049, Part 90.219(4)(e)(iii), 90.210(c)
EUT sample number	S02
Modification state	0
SE in test environment	None
SE isolated from EUT	None
EUT set up	Refer to Appendix C

Modulation Type	Frequency Of Operation Channel (MHz)		
	450.0125	460.0000	469.9875
Analogue	10.152 kHz	10.096 kHz	10.152 kHz

As per D.3 Policies + Procedures (k) of KDB 935210 D02 Signal Boosters Certification v02 the EUT was tested at compression and 10dB into compression to show AGC operation, worst case results taken.

450.0125 Analogue Signal Generator and EUT

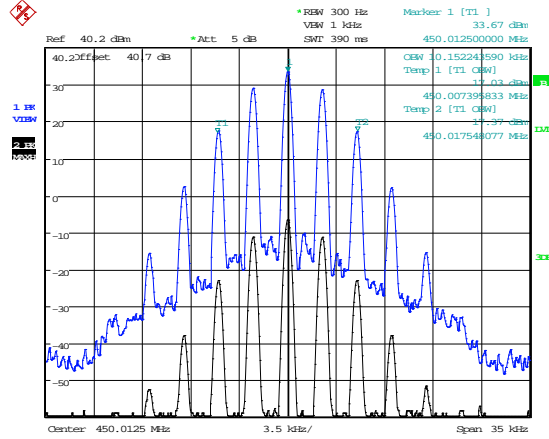

Date: 7.MAR.2014 11:37:45

460.0000 Analogue Signal Generator and EUT

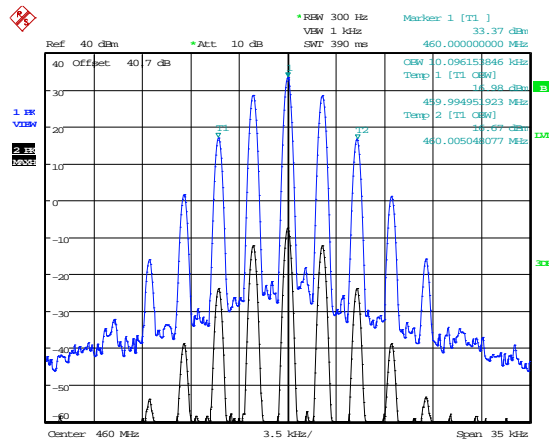

Date: 11.MAR.2014 15:56:44

469.9875 Analogue Signal Generator and EUT

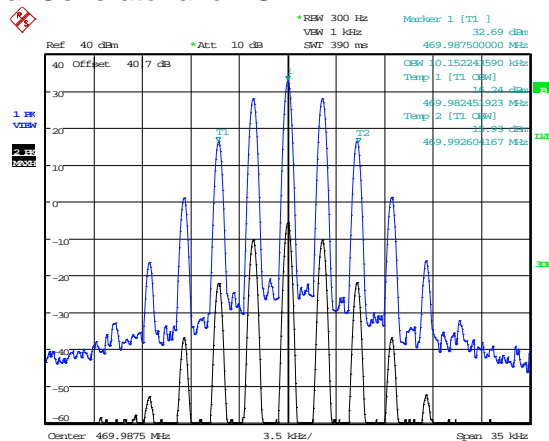

Date: 11.MAR.2014 10:52:41

The above plots depicting the output waveshape show no measurable distortion visible when compared to the input signal.

B4 Spurious Emissions at Antenna Terminals Less than 1MHz

Test Details:	
Measurement standard	Part 2.1053, 90.219(e)(3), 90.210(c)
EUT sample number	S02
Modification state	0
SE in test environment	None
SE isolated from EUT	None
EUT set up	Refer to Appendix C

Modulation Type	Bandedge	Carrier Frequency (MHz)	Max Level @ bandedge (dBm)
Analogue	Lower	450.0125	-36.85
	Upper	469.9875	-38.09

Analogue Signal – Lower Bandedge

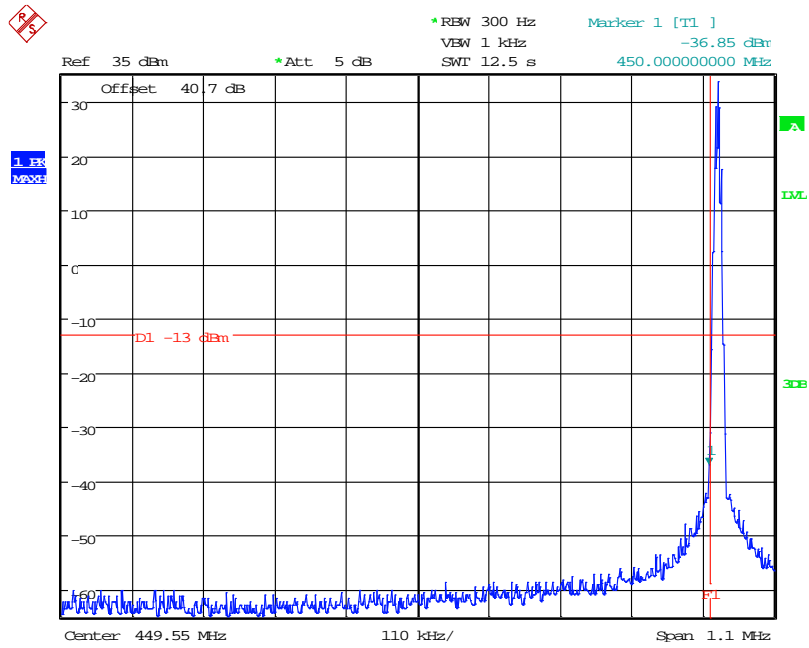

Date: 7.MAR.2014 11:35:38

Analogue Signal – Upper Bandedge

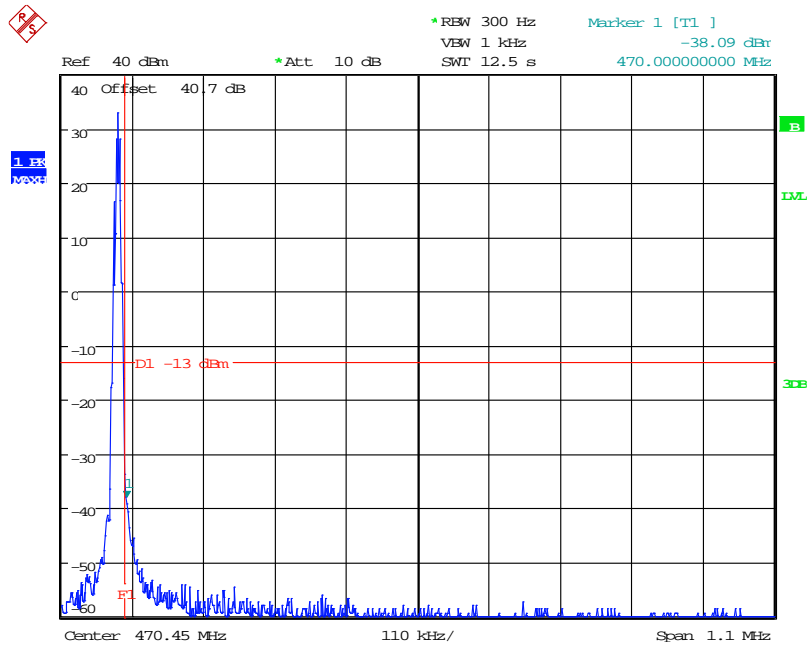

Date: 11.MAR.2014 10:54:59

B5 Spurious Emissions at Antenna Terminals Greater than 1MHz

Test Details:	
Measurement standard	Part 2.1053, 90.219(e)(3)
EUT sample number	S02
Modification state	0
SE in test environment	None
SE isolated from EUT	None
EUT set up	Refer to Appendix C

Bottom Channel

Frequency Range (MHz)	Freq. of Emission (MHz)	Measured Level (dBm)	Attenuator & Cable Losses (dB)	Spurious Emission Level (dBm)	Limit dBm
9kHz - 2GHz	No Significant Emissions Within 10 dB of the Limit				-13

Middle Channel

Frequency Range (MHz)	Freq. of Emission (MHz)	Measured Level (dBm)	Attenuator & Cable Losses (dB)	Spurious Emission Level (dBm)	Limit dBm
9kHz - 2GHz	No Significant Emissions Within 10 dB of the Limit				-13

Top channel

Frequency Range (MHz)	Freq. of Emission (MHz)	Measured Level (dBm)	Attenuator & Cable Losses (dB)	Spurious Emission Level (dBm)	Limit dBm
9kHz - 2GHz	No Significant Emissions Within 10 dB of the Limit				-13

Limit is determined by the outermost step of the emissions mask and is calculated as follows:

At least $43 + 10 \log P$ dB

$$(10 \log P_{\text{watts}}) - (43 + 10 \log (P_{\text{watts}} * 1000)) = \text{LIMIT} = -13 \text{ dBm}$$

Result

The EUT was found to comply with the limits

Spurious Emissions at Antenna Terminals Greater than 1MHz

450.0125

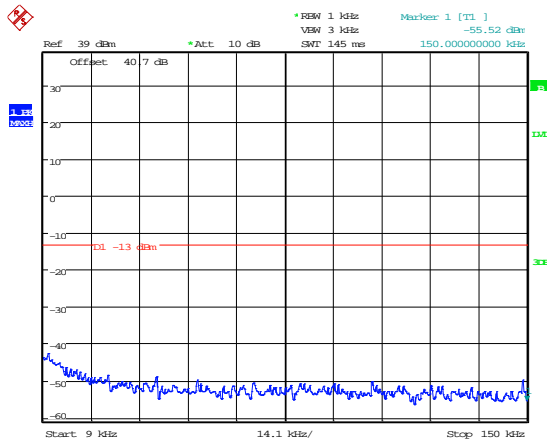

Date: 7.MAR.2014 11:40:02

9-150kHz

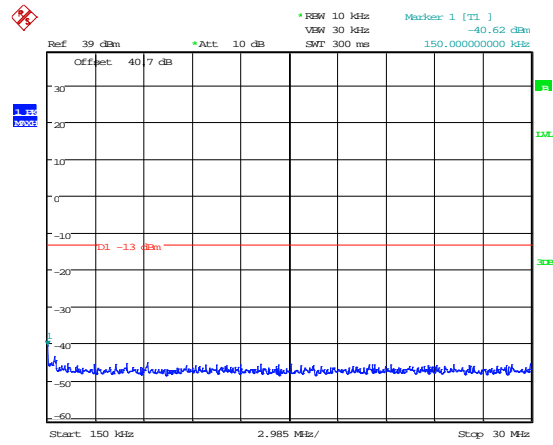

Date: 7.MAR.2014 11:41:07

150kHz – 30MHz

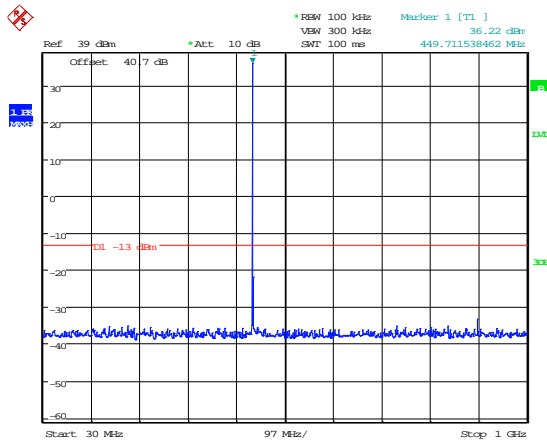

Date: 7.MAR.2014 11:39:28

30MHz – 1GHz

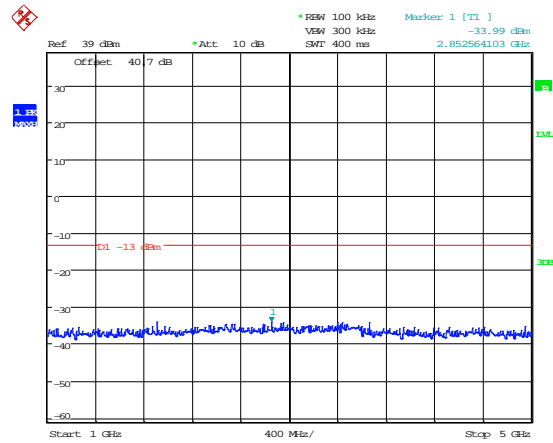

Date: 7.MAR.2014 11:39:40

1GHz – 5GHz

Spurious Emissions at Antenna Terminals Greater than 1MHz

460.0000

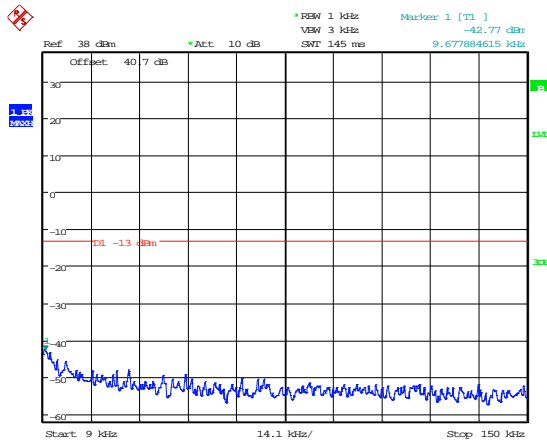

Date: 11.MAR.2014 15:53:18

9-150kHz

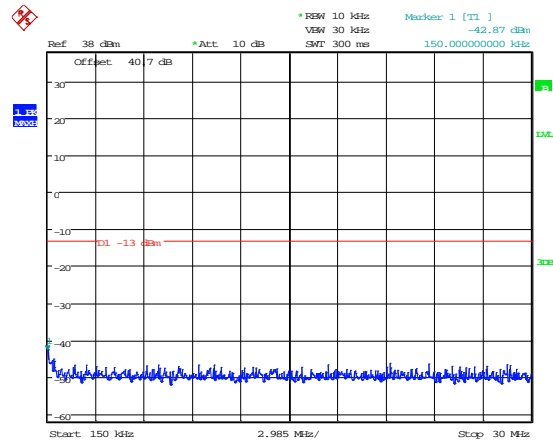

Date: 11.MAR.2014 15:53:31

150kHz – 30MHz

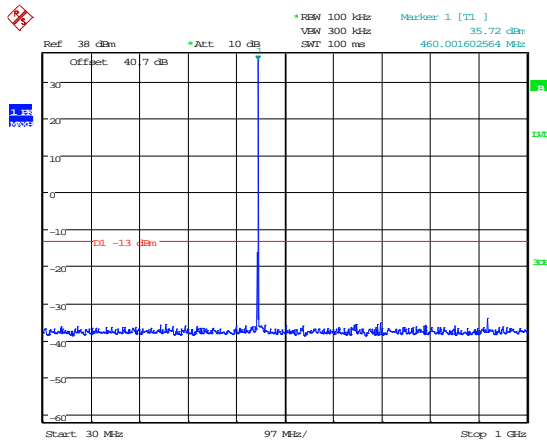

Date: 11.MAR.2014 15:52:54

30MHz – 1GHz

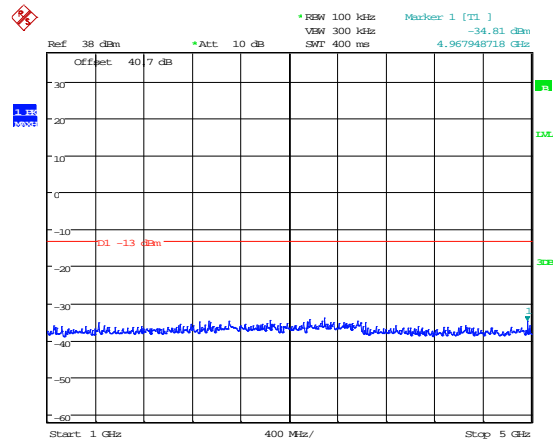

Date: 11.MAR.2014 15:53:05

1GHz – 5GHz

Spurious Emissions at Antenna Terminals Greater than 1MHz

469.9875

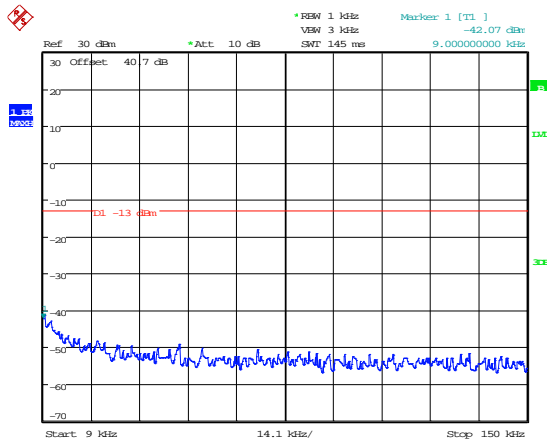

Date: 11.MAR.2014 10:33:45

9-150kHz

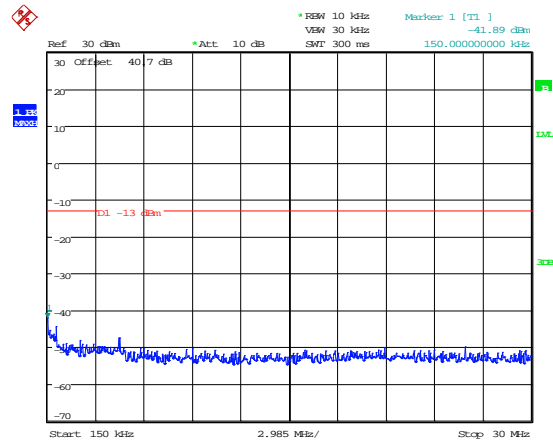

Date: 11.MAR.2014 10:33:59

150kHz – 30MHz

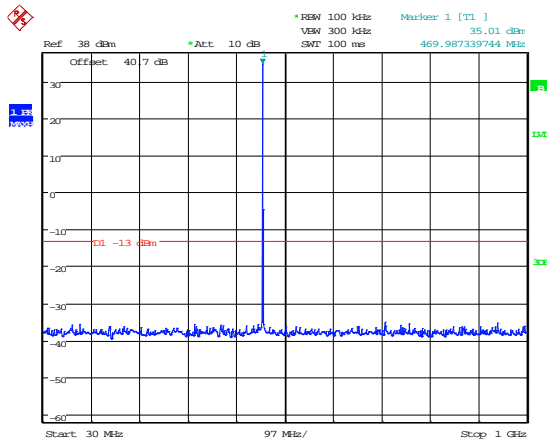

Date: 11.MAR.2014 10:33:19

30MHz – 1GHz

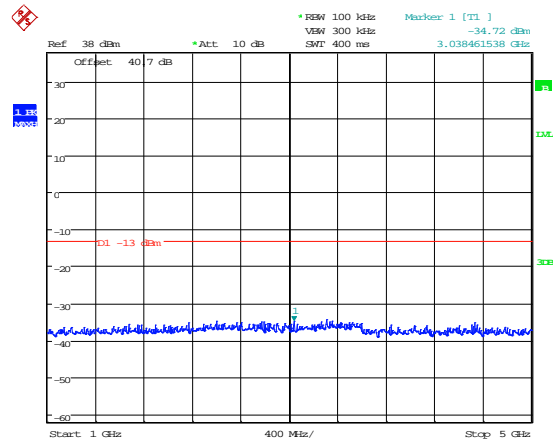

Date: 11.MAR.2014 10:33:29

1GHz – 5GHz

B6 Noise at Antenna Terminals

Test Details:	
Measurement standard	90.219(e)(2), 90.219(d)(6)
EUT sample number	S02
Modification state	0
SE in test environment	None
SE isolated from EUT	None
EUT set up	Refer to Appendix C

Compliance with these levels will be deemed satisfaction of the good engineering practice requirement. In a 10 kHz measurement bandwidth:

- (1) the ERP of noise within the signal booster passband should not exceed -43dBm ;
- and
- (2) the ERP of noise on spectrum more than 1 MHz outside of the signal booster passband should not exceed -70 dBm .
- (3) The noise figure of a signal booster must not exceed 9 dB in either direction

See appendix D for declaration of good engineering practice.

IN BAND AMPLIFIER NOISE – Lower 5 MHz Band

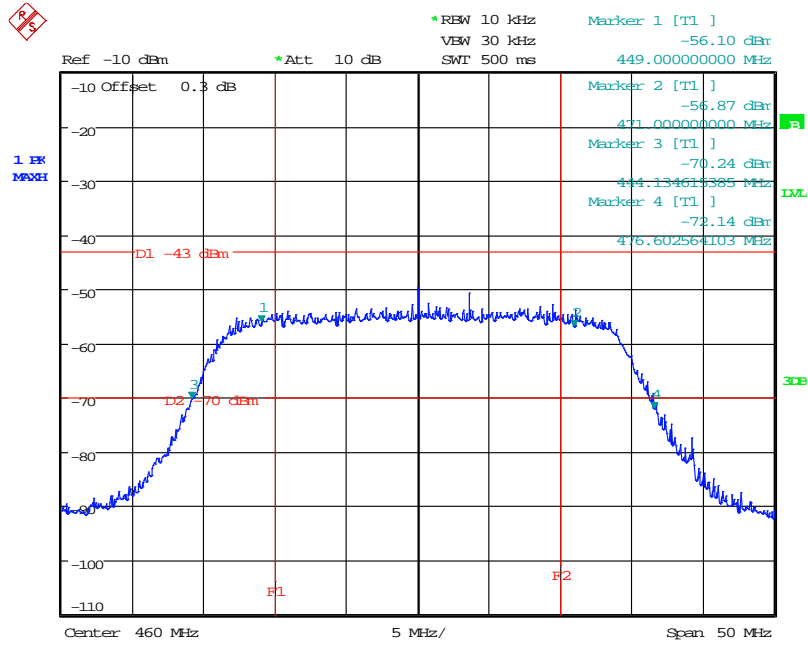

Date: 7.MAR.2014 11:59:40

IN BAND AMPLIFIER NOISE – Upper 5 MHz Band

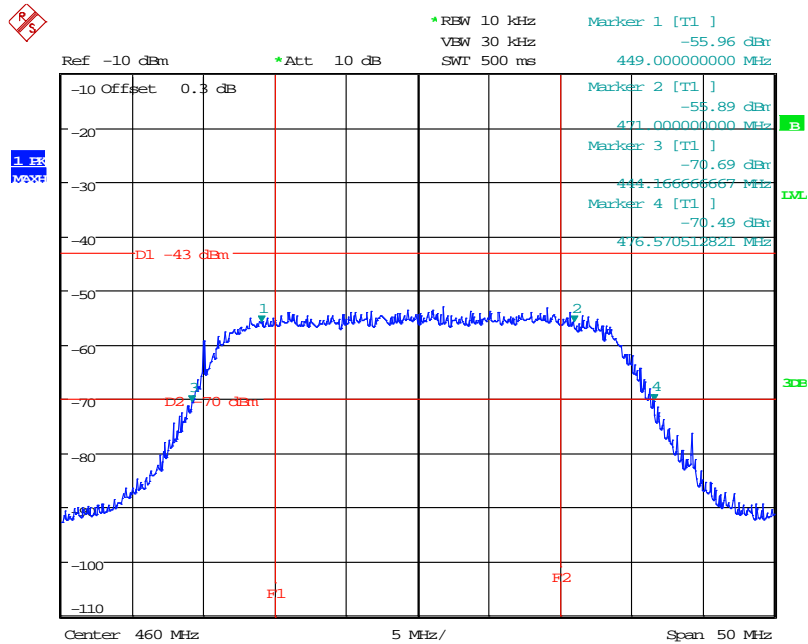

Date: 11.MAR.2014 10:59:54

Signal booster noise figure

Test equipment set up:-

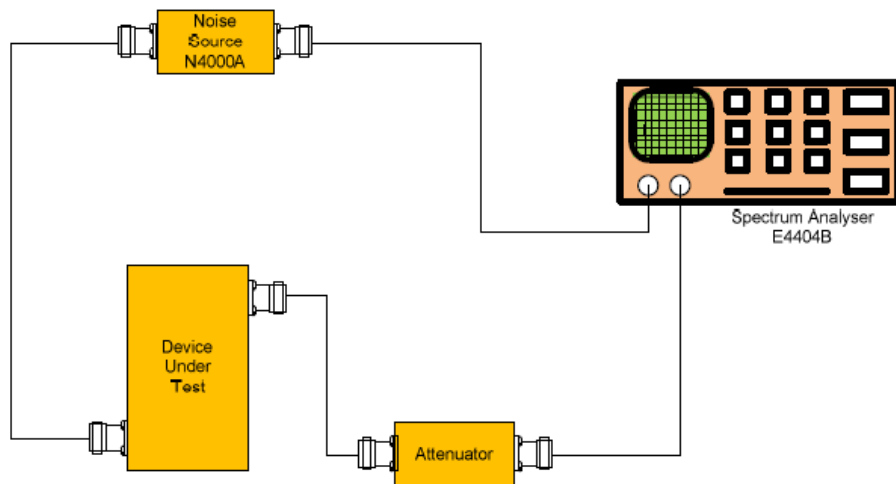

Result

Plots for noise figure, taken with the 18MHz filter applied at maximum gain with 70dB external attenuators in the test set up

Frequency (MHz)	Noise Figure dB
450.0125	2.738 dB
469.9875	3.917 dB

General notes about measurement setup:

- 1) The spectrum analyser has the noise figure measurement personality enabled.

Noise Figure – 450.0125 MHz

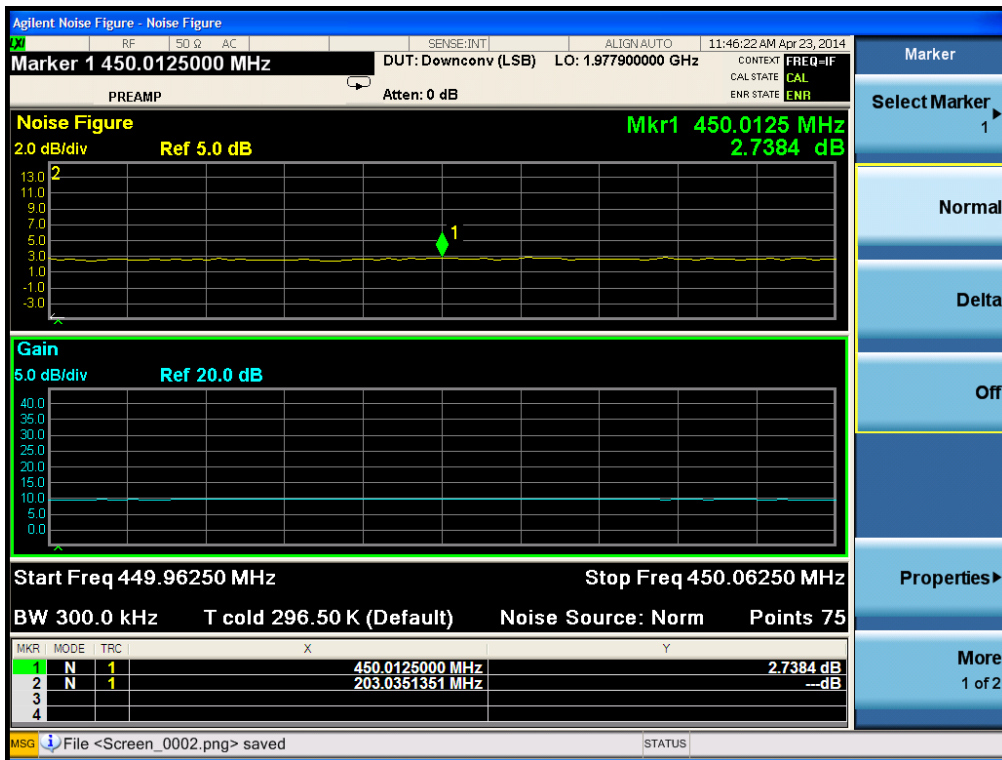

Noise Figure – 469.9875 MHz

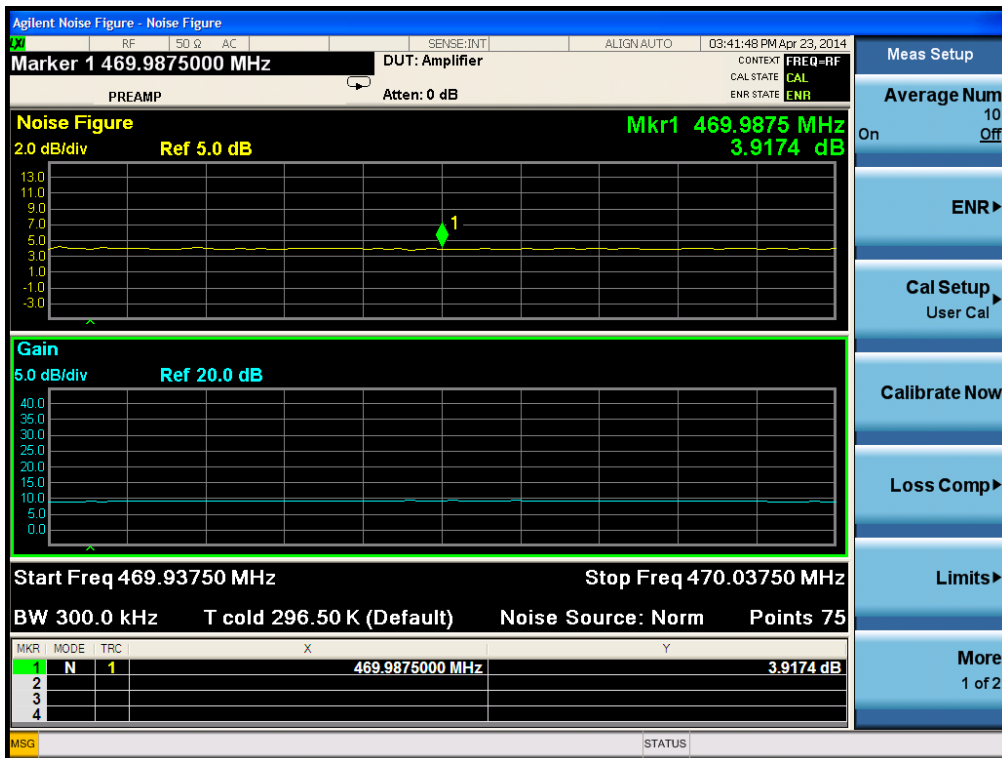

B7 Radiated Electric Field Emissions

Preliminary scans were performed using a peak detector with the RBW = 100kHz. The radiated electric field emission test applies to all spurious and harmonic emissions . The EUT was set to transmit as required.

The following test site was used for final measurements as specified by the standard tested to:

3m open area test site : 3m alternative test site :

The effect of the EUT set-up on the measurements is summarised in note (c) below.

Test Details:	
Measurement standard	Title 47 of the CFR: Part 2.1053, RSS-131 Section 4.3.2
Frequency range	30 MHz – 2 GHz
EUT sample number	S02
Modification state	0
SE in test environment	None
SE isolated from EUT	None
EUT set up	Refer to Appendix C

Bottom Frequency

FREQUENCY RANGE	FREQ. (MHz)	ERP/EIRP (dBm)	LIMIT (dBm)
30MHz - 5GHz	No Significant Emissions Within 10 dB of the Limit		-13

Middle Frequency

FREQUENCY RANGE	FREQ. (MHz)	ERP/EIRP (dBm)	LIMIT (dBm)
30MHz - 5GHz	No Significant Emissions Within 10 dB of the Limit		-13

Top Frequency

FREQUENCY RANGE	FREQ. (MHz)	ERP/EIRP (dBm)	LIMIT (dBm)
30MHz - 5GHz	No Significant Emissions Within 10 dB of the Limit		-13

Result

The EUT was found to comply with the limits

Notes:

1. Emissions Checked up to 10 times Fc.
2. The unit was mounted on a turntable and rotated through 360⁰ and in 3 orthogonal planes to find the worst case emission.
3. For Frequencies below 1 GHz, RBW = 120 kHz, testing was performed with CISPR16 compliant test receiver with QP detector. Above 1 GHz tests were performed using a spectrum analyser using the following settings:

Peak Detector RBW = 1MHz; VBW = ≥RBW

4. Limit is determined as the outermost step of the emissions mask and is calculated as follows.

At least 43 + 10 log P dB

$$(10\log P_{\text{watts}}) - (43 + 10\log (P_{\text{watts}} * 1000)) = \text{LIMIT } = -13 \text{ dBm}$$

The upper and lower frequency of the measurement range was decided according to 47 CFR Part 2.1057.

- (a) Where results have been measured at one distance, and a signal level displayed at another, the results have been extrapolated using the following formula:

$$\text{Extrapolation (dB)} = 20 \log_{10} \left(\frac{\text{measurement distance}}{\text{specification distance}} \right)$$

- (b) The levels may have been rounded for display purposes.
- (c) The following table summarises the effect of the EUT operating mode, internal configuration and arrangement of cables / samples on the measured emission levels :

	See (i)	See (ii)	See (iii)	See (iv)
Effect of EUT operating mode on emission levels	✓			
Effect of EUT internal configuration on emission levels	✓			
Effect of Position of EUT cables & samples on emission levels	✓			
(i) Parameter defined by standard and / or single possible, refer to Appendix D (ii) Parameter defined by client and / or single possible, refer to Appendix D (iii) Parameter had a negligible effect on emission levels, refer to Appendix D (iv) Worst case determined by initial measurement, refer to Appendix D				

Radiated Electric Field Emissions

450.0125

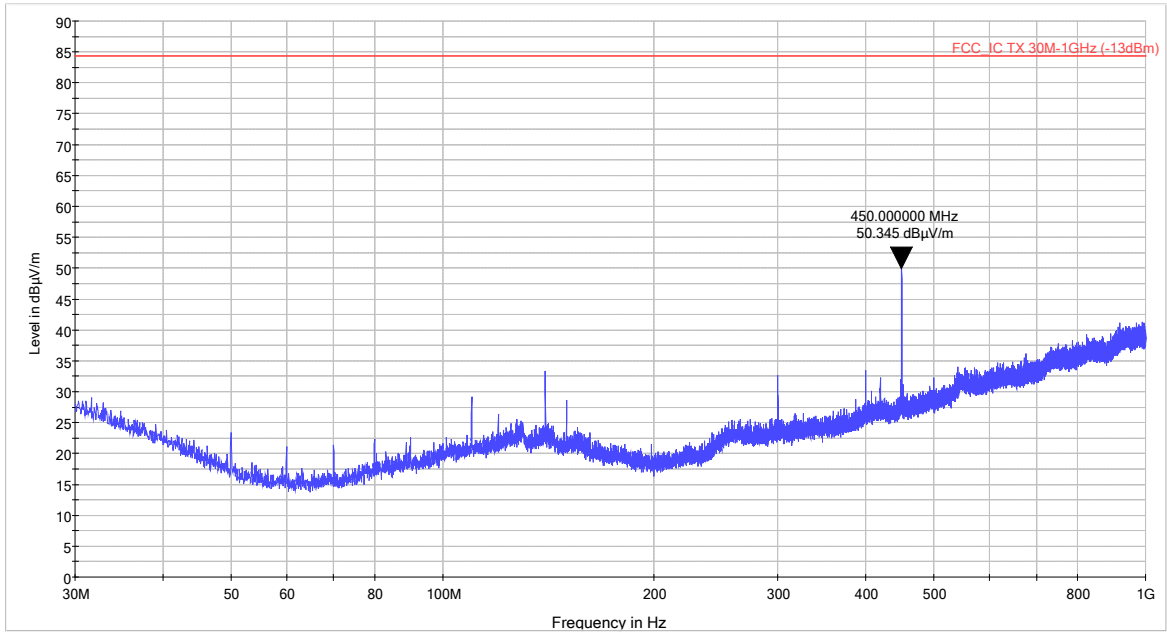

30MHz – 1GHz

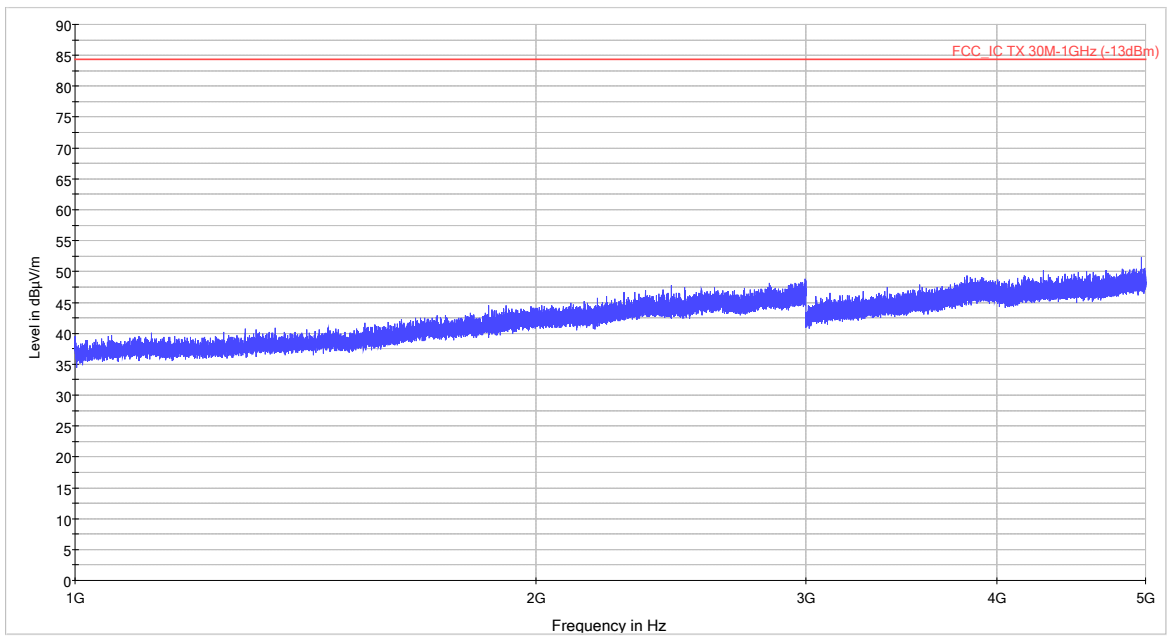

1GHz – 5GHz

Radiated Electric Field Emissions

460.0000

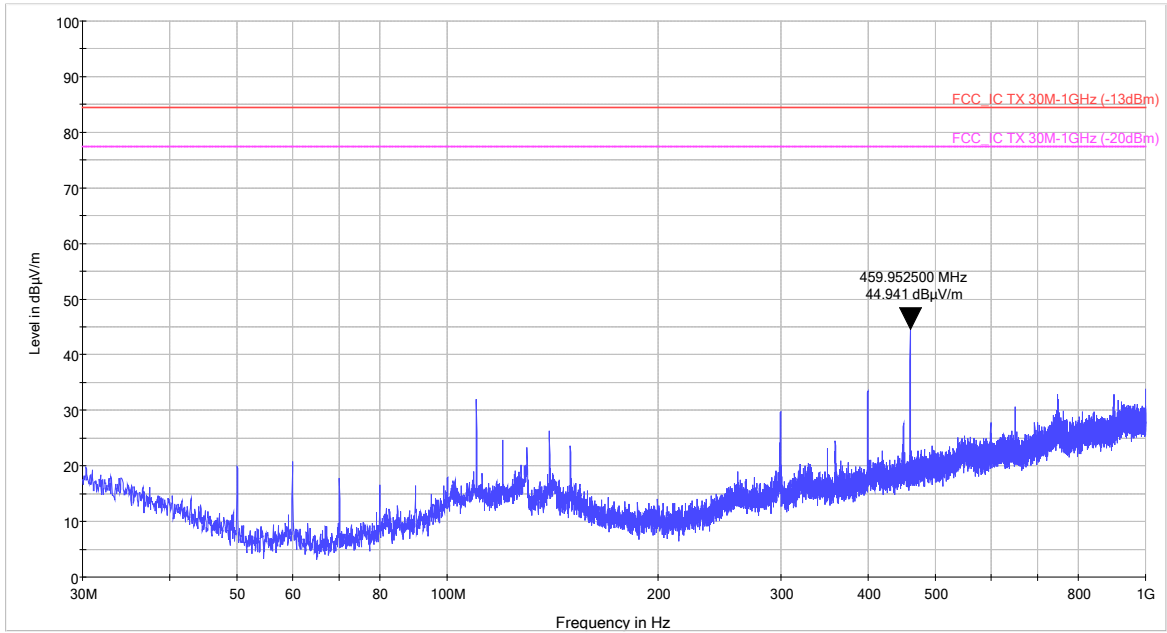

30MHz – 1GHz

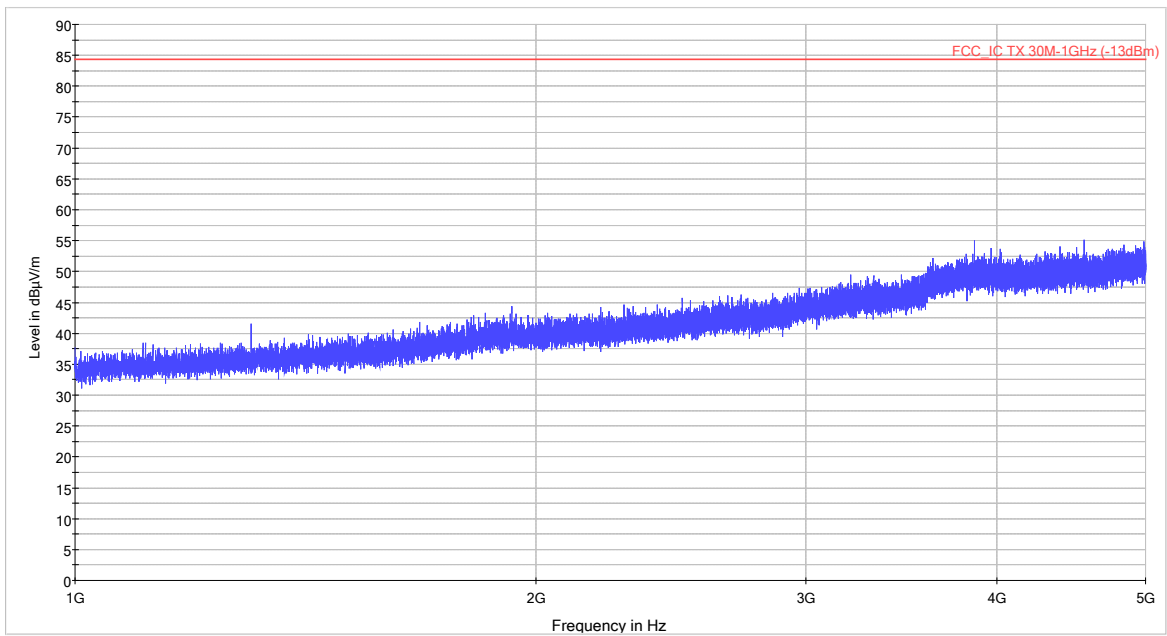

1GHz – 5GHz

Radiated Electric Field Emissions

469.9875

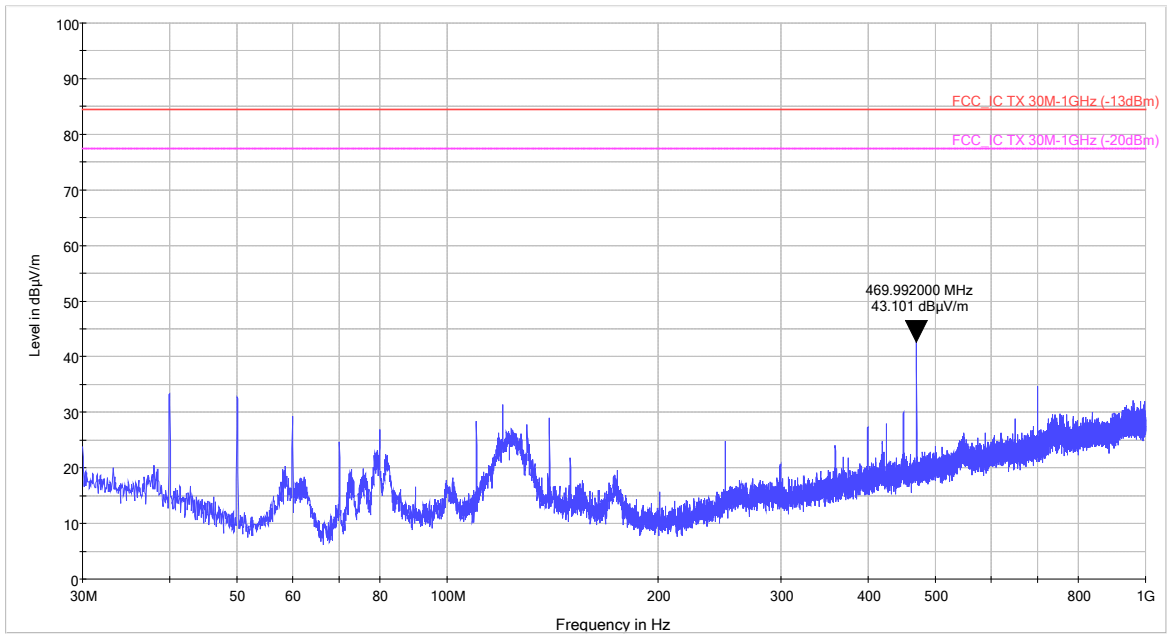

30MHz – 1GHz

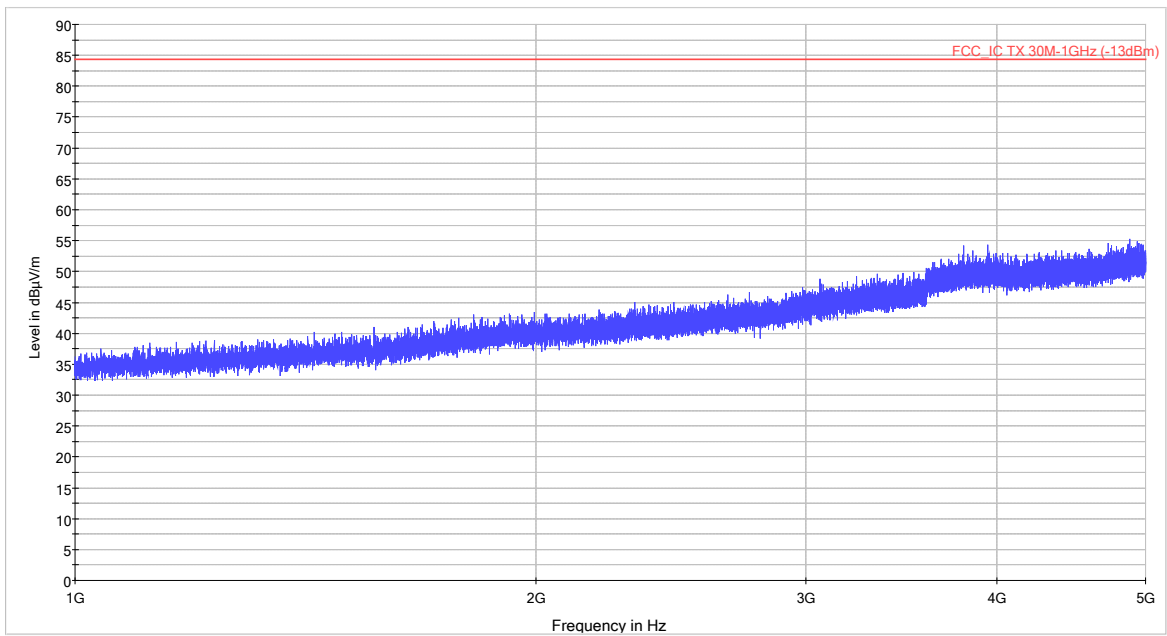

1GHz – 5GHz

B8 Passband Gain & Bandwidth

Test Details:	
Measurement standard	RSS-131 Section 4.2
	D.3 Policies + Procedures (k) of KDB 935210 D02 Signal Boosters Certification v02
EUT sample number	30 MHz – 2 GHz
Modification state	S02
SE in test environment	0
SE isolated from EUT	None
EUT set up	Refer to Appendix C

Frequency MHz	Fl MHz	Fh MHz	20 dB Bandwidth
450.0125	449.977403846	450.035096154	57.692 kHz
469.9875	469.963301282	470.024198718	60.897 kHz
450 – 470	449.977403846	470.024198718	20.047 MHz

1. See below for plots showing passband gain & bandwidth

With the aid of a CW Swept signal generator and spectrum analyser, the bandwidth and frequency response of the open channel (i.e. at the point where the gain has fallen by 20 dB) is measured. This measurement shows the gain-versus-frequency response of the open channel from the midband frequency f_0 of the channel up to at least $f_0 + 250\%$ of the 20 dB bandwidth.

Lower 5 MHz band – 450.00625 MHz

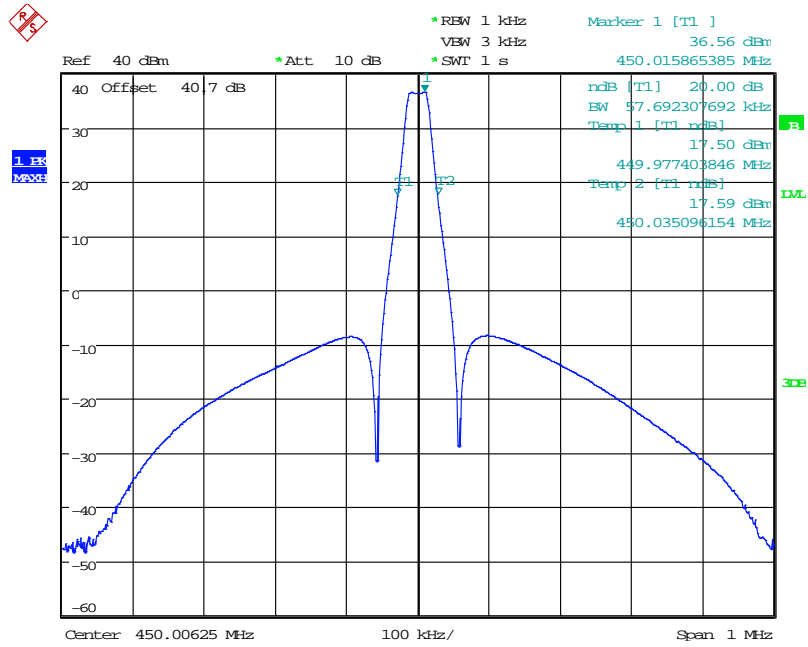

Date: 10.MAR.2014 10:41:36

Upper 5 MHz band – 469.99375 MHz

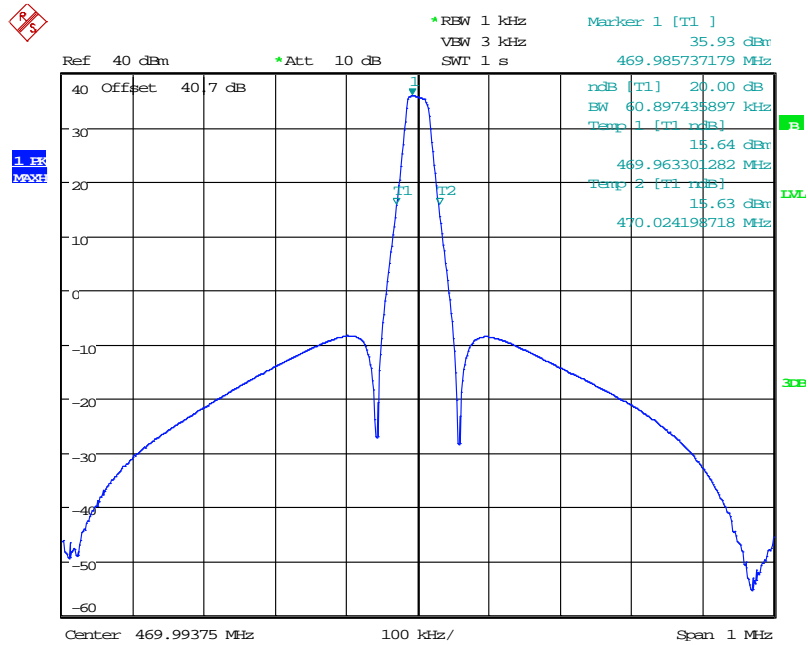

Date: 11.MAR.2014 10:22:58

Appendix C:**Additional Test and Sample Details**

This appendix contains details of:

1. The samples submitted for testing.
2. Details of EUT operating mode(s)
3. Details of EUT configuration(s) (see below).
4. EUT arrangement (see below).

Throughout testing, the following numbering system is used to identify the sample and its modification state:

Sample No: Sxx Mod w

where:

xx	= sample number	eg. S02
w	= modification number	eg. Mod 2

The following terminology is used throughout the test report:

Support Equipment (SE) is any additional equipment required to exercise the EUT in the applicable operating mode. Where relevant SE is divided into two categories:

SE in test environment: The SE is positioned in the test environment and is not isolated from the EUT (e.g. on the table top during REFE testing).

SE isolated from the EUT: The SE is isolated via filtering from the EUT. (e.g. equipment placed externally to the ALSR during REFE testing).

EUT configuration refers to the internal set-up of the EUT. It may include for example:

- Positioning of cards in a chassis.
- Setting of any internal switches.
- Circuit board jumper settings.
- Alternative internal power supplies.

Where no change in EUT configuration is **possible**, the configuration is described as "single possible configuration".

EUT arrangement refers to the termination of EUT ports / connection of support equipment, and where relevant, the relative positioning of samples (EUT and SE) in the test environment.

For further details of the test procedures and general test set ups used during testing please refer to the related document "EMC Test Methods - An Overview", which can be supplied by TRaC Global upon request.

C1) Test samples

The following samples of the apparatus were submitted by the client for testing :

Sample No.	Description	Identification
S02	D-CSR-4004-8-450-470-DP-AC	26846G

The following samples of apparatus were submitted by the client as host, support or drive equipment (auxiliary equipment):

Sample No.	Description	Identification
None		

The following samples of apparatus were supplied by TRaC Global as support or drive equipment (auxiliary equipment):

Identification	Description
None	

C2) EUT Operating Mode During Testing.

During testing, the EUT was exercised as described in the following tables :

Test	Description of Operating Mode
All tests detailed in this report	Receiving a signal to ensure EUT is operating a maximum gain and maximum output power.

C3) EUT Configuration Information.

The EUT was submitted for testing in one single possible configuration.

C4) List of EUT Ports

The tables below describe the termination of EUT ports:

Sample : S02
Tests : Conducted

Port	Description of Cable Attached	Cable length	Equipment Connected
U/L DAS	Coaxial	>1m	Measurement System or 50Ω Load
D/L DAS	Coaxial	>1m	Measurement System or 50Ω Load
U/L Donor Antenna	Coaxial	>1m	Measurement System or 50Ω Load
D/L Donor Antenna	Coaxial	>1m	Measurement System or 50Ω Load

Sample : S02
Tests : Radiated Emissions

Port	Description of Cable Attached	Cable length	Equipment Connected
U/L DAS	Coaxial	>1m	Measurement System or 50Ω Load
D/L DAS	Coaxial	>1m	Measurement System or 50Ω Load
U/L Donor Antenna	Coaxial	>1m	Measurement System or 50Ω Load
D/L Donor Antenna	Coaxial	>1m	Measurement System or 50Ω Load

* Only connected during setup.

C5 Details of Equipment Used

TRaC No	Equipment Type	Equipment Description	Manufacturer	Last Cal Calibration
UH003	ESHS10	Receiver	R&S	08/05/2013
UH004	ESVS10	Receiver	R&S	27/02/2014
UH028	UHALP 9108	Log Periodic Ant	Schwarbeck	08/07/2013
UH029	VHBA 9123	Bicone Antenna	Schwarbeck	19/08/2013
UH093	CBL6112B	Bilog	Chase	08/07/2013
UH096	6960B	Power meter	Marconi	16/12/2013
UH122	TDS520B	Oscilloscope	Tektronix	11/04/2012
UH129	6924	Power Sensor	Marconi	16/12/2013
UH187	ESHS10	Receiver	R&S	19/02/2014
UH191	CBL611/A	Bilog	Chase	13/12/2012
UH195	ESH3-Z5.831.5	Lisn	R&S	03/07/2013
UH228	6920	Power Sensor	Marconi	16/12/2013
UH281	FSU46	Spectrum Analyser	R&S	26/03/2014
UH287	6920	30 dB reference Attenuator	HP	16/12/2013
UH385	HL 050	Log Periodic Antenna	R&S	16/07/2012
UH387	ATS	Chamber 1	Rainford EMC	04/07/2013
UH388	ATS	Chamber 2	Rainford EMC	04/07/2013
UH396	ENV216	Lisn	R&S	30/04/2013
UH403	ESCI 7	Receiver	R&S	12/08/2013
UH405	FSU26	Spectrum Analyser	R&S	20/03/2013
UH420	CBL6112	Bilog	Chase	06/07/2012
L005	CMTA52	Communications Analyser	R&S	02/12/2013
L007	hfh2	Loop Antenna	R&S	17/10/2013
L138	3115	1-18GHz Horn	EMCO	17/10/2013
L139	3115	1-18GHz Horn	EMCO	20/09/2013
L176	2042	Signal Generator	Marconi	29/11/2013
L254	2042	Signal Generator	Marconi	08/01/2014
L193	VHA 9103 balu	Bicone Antenna	Chase	19/06/2012
L203	UPA6108	Log Periodic Ant	Chase	19/06/2012
L290	CBL611/A	Bilog	Chase	13/12/2012
L300	20240-20	Horn 18-26GHz (&UH330)	Flann	10/02/2014
L317	ESVS10	Receiver	R&S	12/02/2014
L352	ESVS10	Receiver	R&S	21/03/2014
L426	52 Series II	Temperature Indicator	Fluke	29/04/2013
L572	8449B	Pre Amp	Agilent	12/12/2012
L654	8563A	Spectrum Analyser	HP	29/11/2013
REF909	FSU26	Spectrum Analyser	R&S	12/02/2014
REF916	SMBV100A	Signal Generator	R&S	19/02/2014
REF940	ATS	Radio Chamber - PP	Rainford EMC	09/07/2013
REF976	34405a	Multimeter	Agilent	26/04/2013
REF977	SH4141	High Pass Filter	BSC	25/02/2013
REF2083	RPR3006W	Power Meter	DARE	24/10/2013

Appendix D:

Additional Information



FCC Approval Clarification of Axell Channel Selective Repeater products

Axell Wireless has provided 4 samples of their repeater products to Trac UK Type Approval laboratories in order to seek FCC part 90 approval of the equipment. The equipment comprises of:

1. VHF Repeater D-CSR3302 covering frequency range 150-170MHz
2. UHF Repeater D-CSR3604 covering frequency range 450-470MHz
3. UHF Repeater D-CSR3604 covering frequency range 470-490MHz
4. UHF Repeater D-CSR3604 covering frequency range 490-510MHz

Each repeater variant uses a DSP Software Defined Radio filter to provide 8 RF channel frequencies within a 20MHz window of RF spectrum. Internal 20MHz spectrum defining filters have been used to enable testing across the full 20MHz band. Each repeater has independent downlink and uplink paths to accommodate the full band of frequencies.

In normal operation the repeater would consist of a number of narrow band filters that have been duplexed together to form a common input or output port for single antenna operation. The purpose of the filter / duplexer is to ensure that the equipment operating bandwidth is limited to the band of frequencies required to be amplified/repeater. The filter ensures that noise and any Intermodulation is limited to within the operating transmission band. The filter must prevent any noise reaching the antenna port at the receiver frequencies as any noise at this point will affect the ability to receive. The receiver input filter is used to ensure that only the required input band of frequencies is presented to the DSP module. The filter also ensures that the high level transmit output does not cause overload damage of blocking of the receiver ability to detect the wanted input frequencies.

This document will detail the operation for each of the components and provide explanatory drawings of the system and its application to an in-building coverage solution.

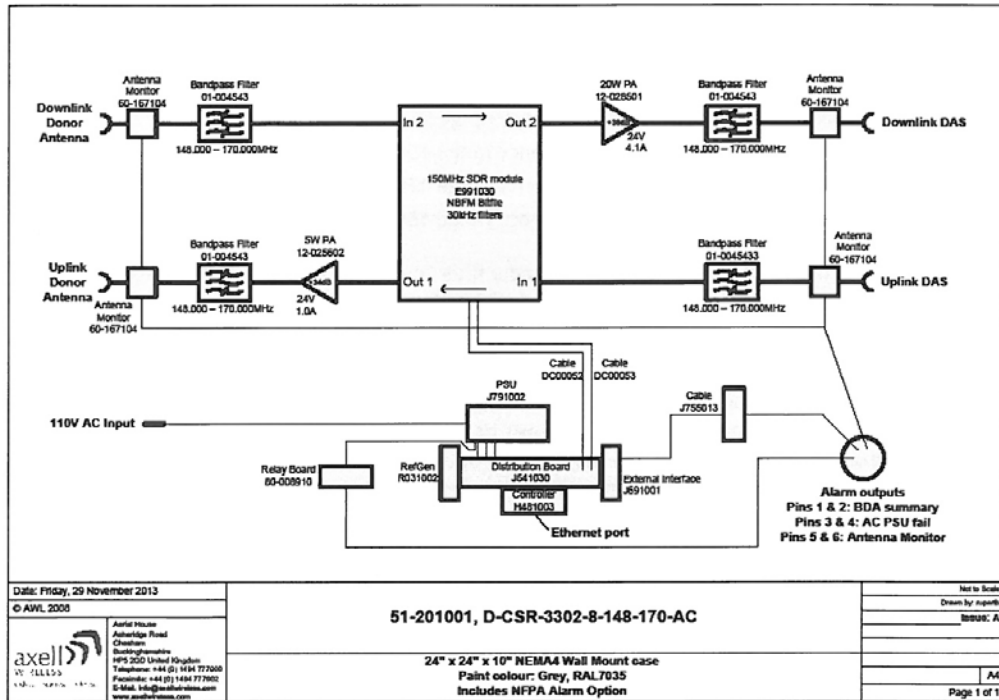

Figure 1. VHF D-CSR3302 for Type approval – Part number 51-201001.

The VHF CSR3302 consists of 4 major components to perform RF amplification of the DL and UL paths.

1. DSP controlled Digital filtering for channel selectivity
2. Downlink amplifier 30dB gain 25w
3. Uplink Amplifier 30dB gain 5w
4. Input and output spectrum defining band pass filters for band selectivity.

There are also a number of supporting modules including PSU, Alarm interfacing and a Management controller to provide the channel frequency entry, gain setting and squelch threshold. Antenna monitoring and PSU detection components are also included to meet the NFPA requirements.

1. The DSP controlled digital filter module provides 8 channel selectivity in both the DL and UL directions. The channel filter has 2 bandwidth options of 15 kHz or 30 kHz bandwidth. The module consists on a 30dB gain low noise input amplifier feeding into an analogue to digital convertor which digitises a 5MHz block of the 20MHz input spectrum.



FCC Approval Clarification

2. The digitised signal is filtered into the 8 channel windows as set by the frequency and bandwidth information entered. A digital squelch with adjustable threshold is set to enable the signal output above a predetermined input signal level over the range of -60dBm to -108dBm. The digitised filtered output is then fed via a Digital to analogue convertor into a 30dB gain pre driver amplifier to feed the output amplifier.
3. The Downlink output amplifier utilises high linearity class A techniques to minimise Intermodulation generation in the presence of multiple carriers.
4. The uplink output amplifier utilises high linearity class A techniques to minimise Intermodulation generation in the presence of multiple carriers.
5. The input and output filtering limits the out of band noise and prevents out-of-band signals from overloading the DSP module.

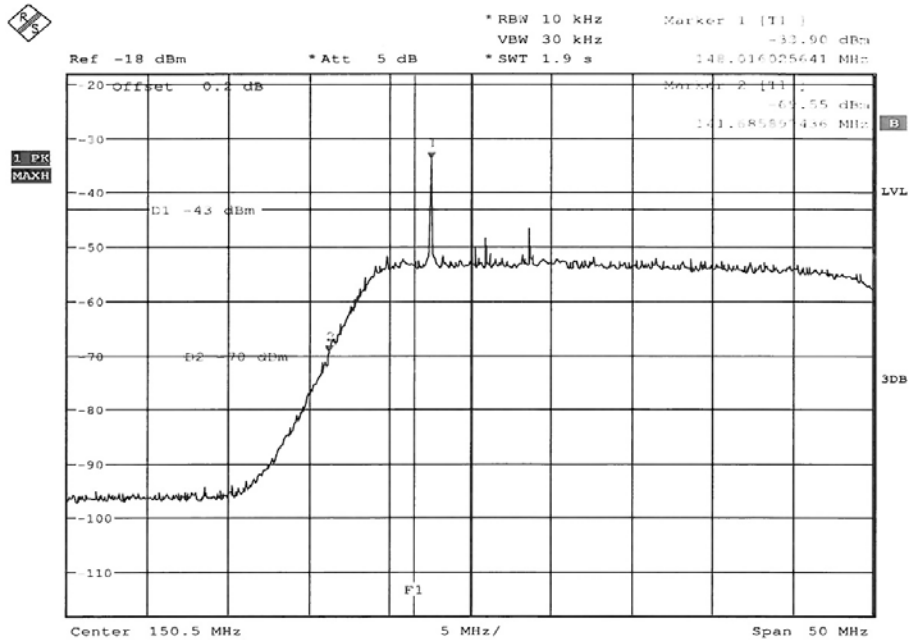

Date: 7.FEB.2014 10:37:02

Figure 2. VHF D-CSR3302 – Typical Noise performance of unit with 20MHz spectrum filter

Notes: In band spurious noise level nominally -50dBm.
 Band edge rejection of -70dBm will be much improved by conventional duplexing.



FCC Approval Clarification

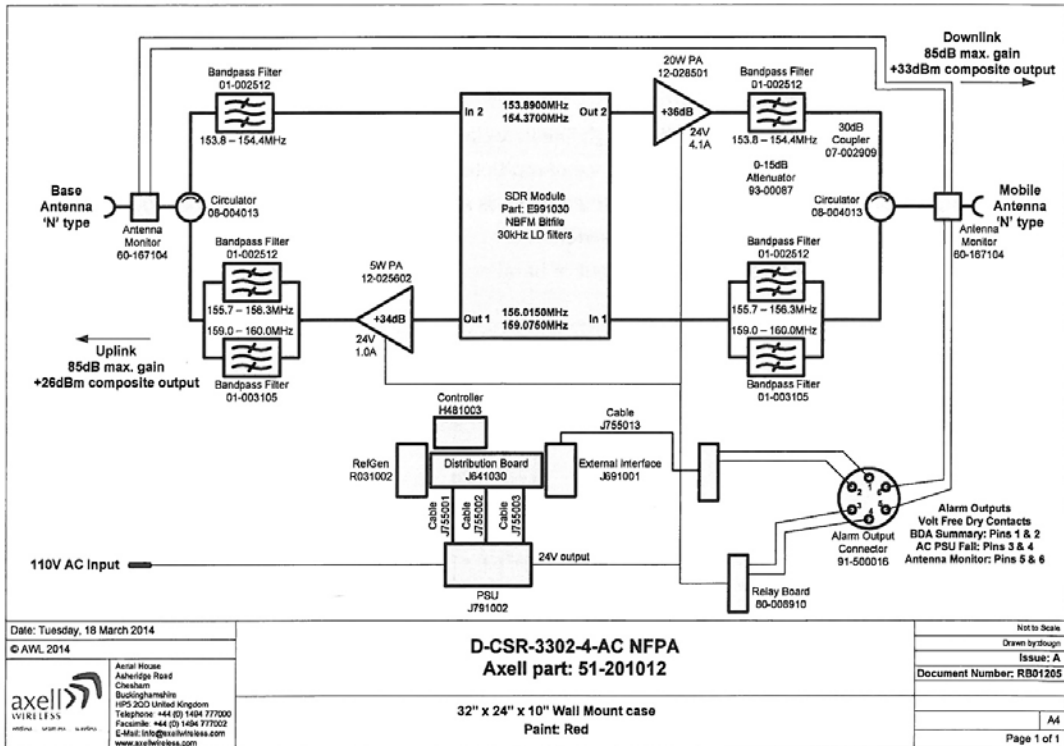

Figure 3. VHF D-CSR3302 – Typical arrangement for single port operation using duplexer filters.

The repeater shown above provides 3 duplex carriers within a 3MHz passband. A dual DAS arrangement is used within the infill area, the donor and mobile antenna ports includes an isolator to enhance the UL to DL isolation. A typical plot of the band pass filter is shown in figure 4, below.



FCC Approval Clarification

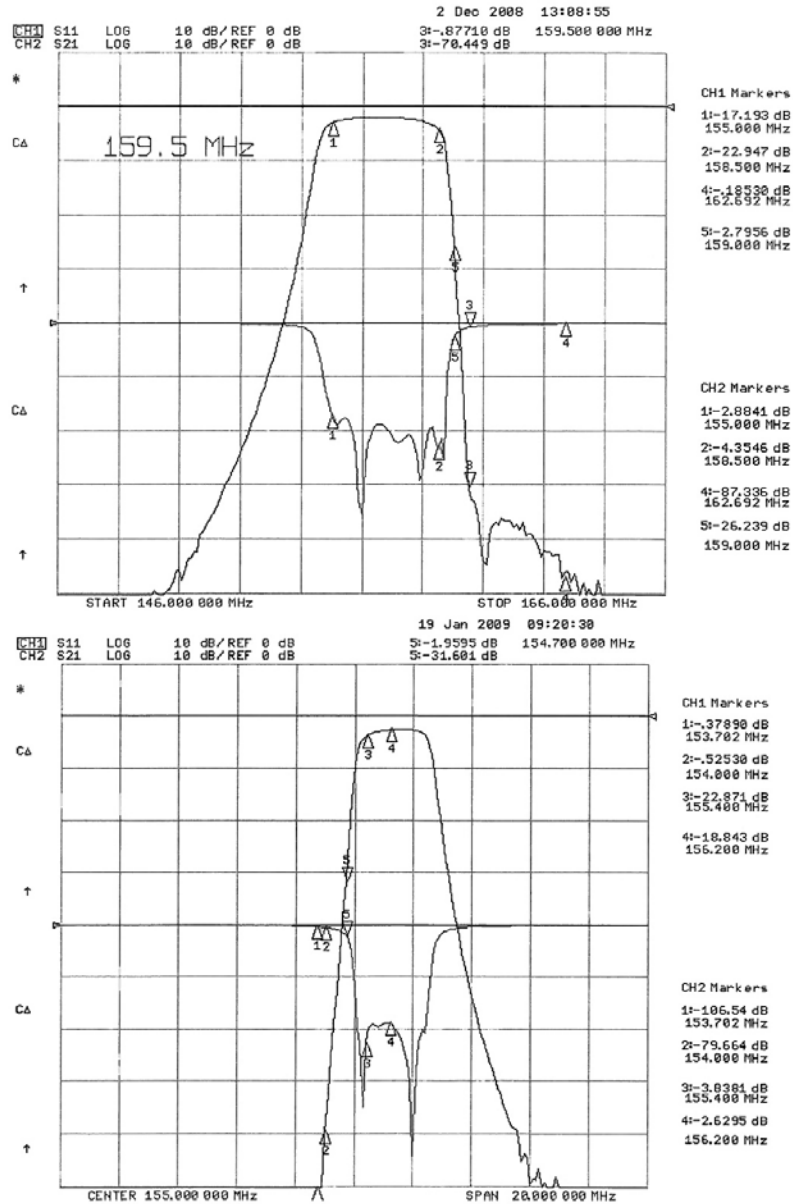

Figure 4. Examples - frequency response of VHF filter type 01-002612.

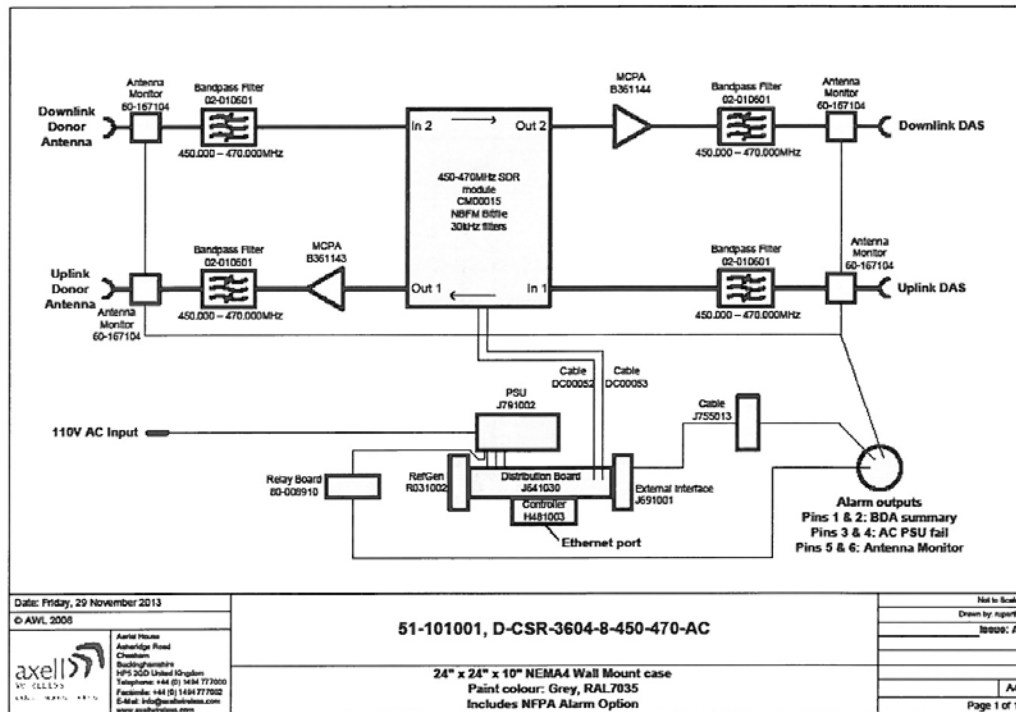

Figure 5. UHF D-CSR3604 for Type approval – Part number 51-101001.

The UHF CSR3604 consists of 4 major components to perform RF amplification of the DL and UL paths.

1. DSP controlled Digital filtering for channel selectivity
2. Downlink amplifier 30dB gain 25w
3. Uplink Amplifier 30dB gain 5w
4. Input and output spectrum defining band pass filters for band selectivity (3 bands of 20MHz for UHF spectrum 450-510MHz).

There are also a number of supporting modules including PSU, Alarm interfacing and a Management controller to provide the channel frequency entry, gain setting and squelch threshold. Antenna monitoring and PSU detection components are also included to meet the NFPA requirements.

1. The DSP controlled digital filter module provides 8 channel selectivity in both the DL and UL directions. The channel filter has 2 bandwidth options of 15 kHz or 30 kHz bandwidth. The module consists on a 30dB gain low noise input amplifier feeding into an analogue to digital convertor which digitises a 5MHz block of the 20MHz input spectrum. The digitised signal is filtered into the 8 channel windows as set by the frequency and bandwidth information entered. A digital squelch



FCC Approval Clarification

- with adjustable threshold is set to enable the signal output above a predetermined input signal level over the range of -60dBm to -108dBm. The digitised filtered output is then fed via a Digital to analogue convertor into a 30dB gain pre driver amplifier to feed the output amplifier.
- 2 The Downlink output amplifier utilises high linearity pre-distorted class A techniques to minimise Intermodulation generation in the presence of multiple carriers.
 - 3 The uplink output amplifier utilises high linearity class A techniques to minimise Intermodulation generation in the presence of multiple carriers.
 - 4 The input and output filtering limits the out of band noise and prevents out-of-band signals from overloading the DSP module.

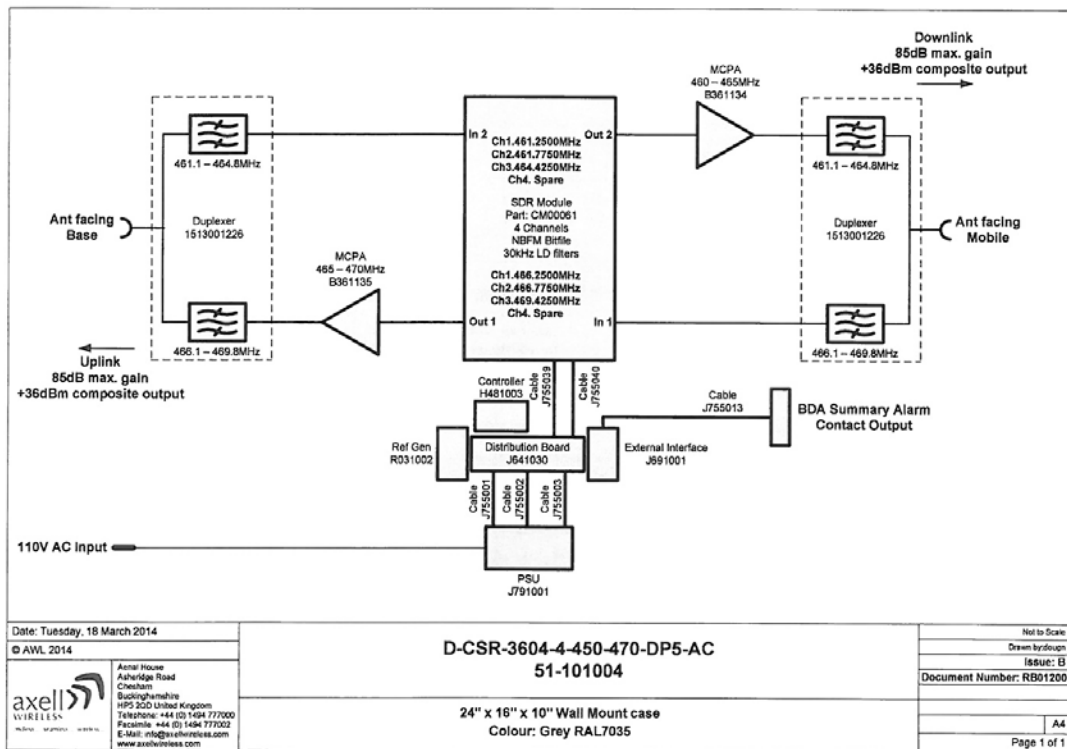

Figure 6. UHF D-CSR3604 – Typical arrangement for single port operation using duplexer filters.

The repeater shown above provides 4 duplex carriers within a 3.7MHz passband. Each path uses a filter duplexer to provide the UL to DL isolation. A typical plot of the filter pass band is shown in figure 7.



FCC Approval Clarification

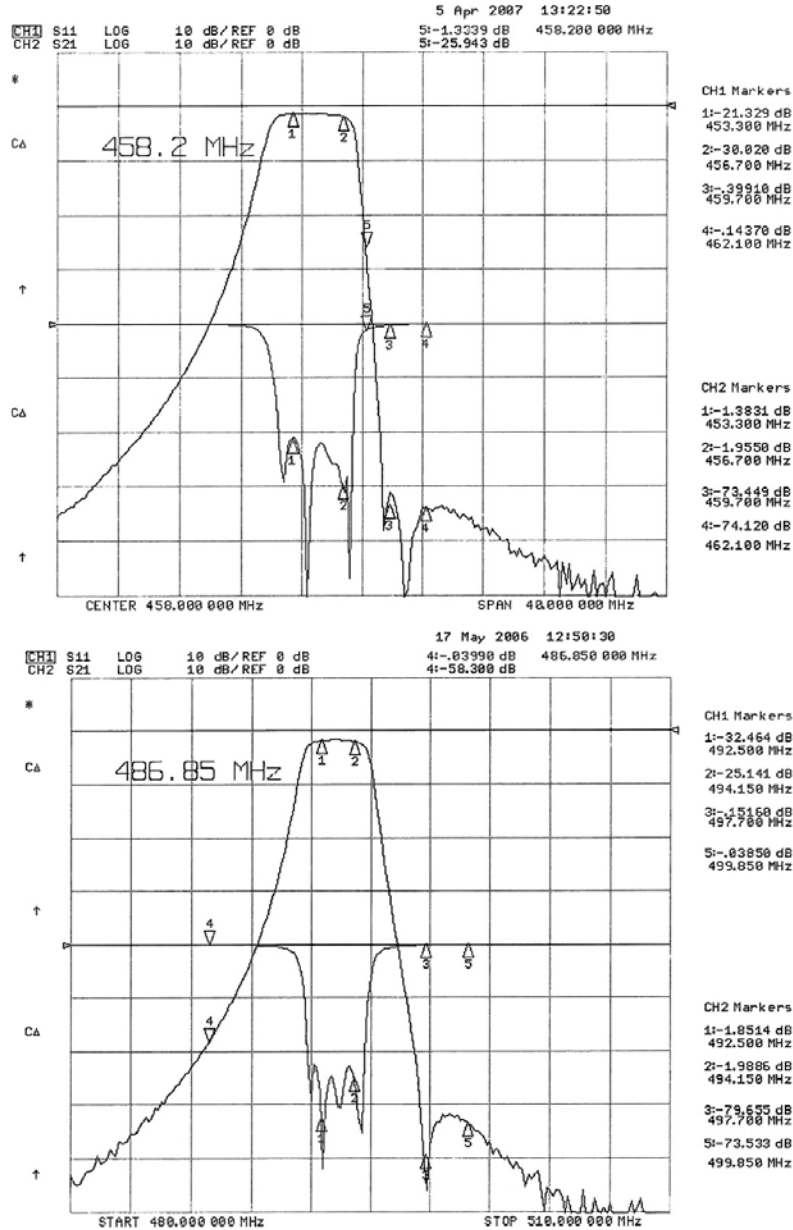

Figure 7. Examples - frequency response of UHF filter type 02-007903.



FCC Approval Clarification

Typical In-building applications for D-CSR repeaters.

The figure 8 below shows a typical example of both VHF and UHF D-CSR repeaters being used to feed a wide area DAS solution within a building. An in-building DAS arrangement would typically have a distribution and splitting loss of 20 – 30dB and hence the output power from the repeater would be reduced by this attenuation before radiating the signal from the antenna. The use of a multiple antenna DAS provides a similar level of signal over a wide area without the issue of near / far signal variation. A further benefit is to reduce radiated signal level any noise and IMD that maybe produced within the repeater.

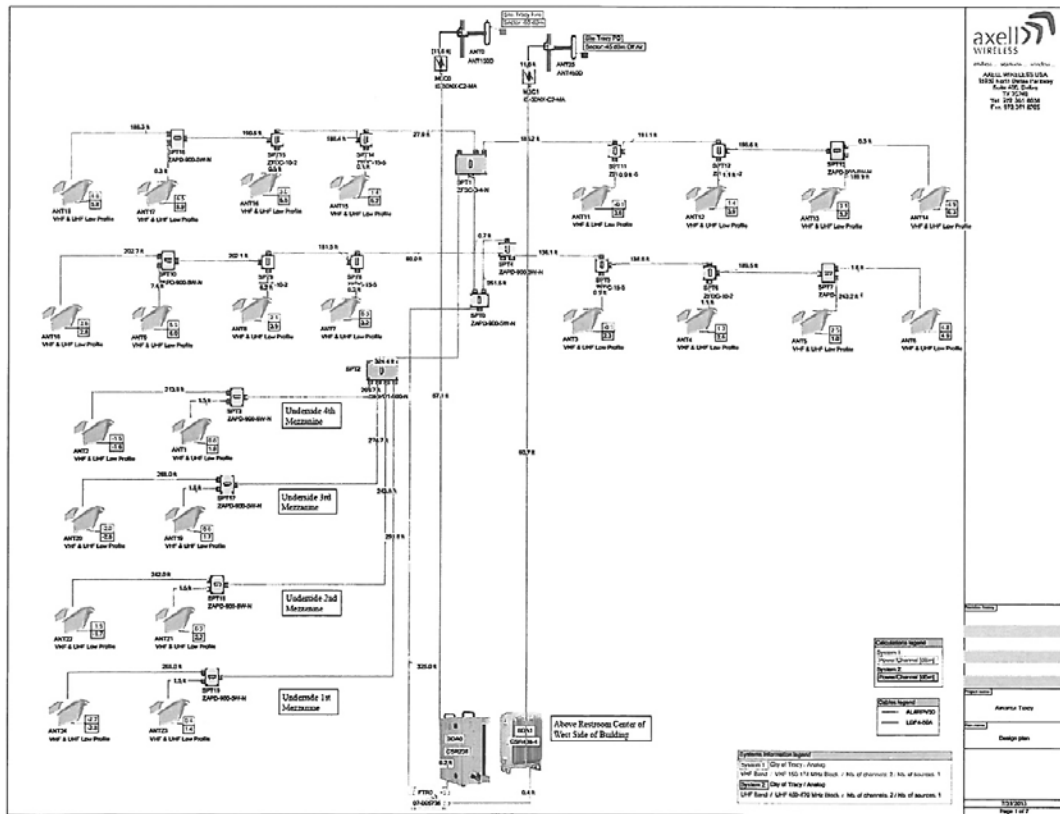



Figure 8. Example – Dual Band VHF / UHF repeater solution for in-building coverage.

**User manual warnings - Class of Booster and Guidelines for Good Working Practice.**

A number of statements regarding FCC compliance and recommendations of good working practice to enable co-existence of systems without interference to other users have been incorporated in the user manual as follows:

Compliance with FCC

	<p>WARNING: This is NOT a CONSUMER device. This device is designed for installation by FCC LICENCEES and QUALIFIED INSTALLERS. You must have an FCC LICENCE or express consent of an FCC Licensee to operate this device.</p> <p>Depending on the software configuration, this device can operate either as a Class A or Class B signal booster. You MUST register Class B signal boosters (as defined in 47 CFR 90.219) online at www.fcc.gov/signal-boosters/registration.</p> <p>Unauthorized use may result in significant forfeiture penalties, including penalties in excess of \$100,000 for each continuing violation.</p> <p>The installation procedure must result in the signal booster complying with FCC requirements 90.219(d). In order to meet FCC requirements 90.219(d), it may be necessary for the installer to reduce the UL and/or DL output power for certain installations.</p>
---	---

FCC Part 15

This device complies with part 15 of the FCC Rules. Operation is subject to the following two conditions:

1. This device may not cause harmful interference, and
2. This device must accept any interference received, including interference that may cause undesired operation.

If not installed and used in accordance with the instructions, this equipment generates, uses and can radiate radio frequency energy. However, there is no guarantee that interference will not occur in a particular installation. If this equipment does cause harmful interference to RF reception, which can be determined by turning the equipment off and on, the user is encouraged to try to correct the interference by one or more of the following measures:

- Reorient or relocate the Donor antenna.
- Increase the separation between the equipment and receiver.
- Connect the equipment into an outlet on a circuit different from that to which the receiver is connected.



Unauthorized Changes to Equipment

Changes or Modifications not expressly approved by the manufacturer responsible for compliance could void the user's authority to operate the equipment

FCC RF Exposure Limits

This unit complies with FCC RF exposure limits for an uncontrolled environment. This equipment can only be installed in in-building applications, driving passive or active DAS systems. All antennas must be operated at a minimum distance of 35 cm between the radiator and any person's body.

Antenna Installation

Installation of an antenna must comply with the FCC RF exposure requirements. The antenna used for this transmitter must be mounted on permanent structures.

The FCC regulation mandate that the EIRP of type A signal boosters should not exceed 5W.

Therefore the max antenna gain allowed for this type of signal booster should be limited to the values given by equation (1) for the service antenna and equation (2) for the donor antenna

Equation (1) - Max SERVICE antenna gain

Max SERVICE antenna gain (dBi) = $37 - (33\text{dbi} - \# \text{ of antennas in dbi} - \text{cable losses in dbi})$.

For example:

No. of Antennas	Cable Losses	Max Allowed Antenna Gain
4	3	$37 - (33-6-3) = 13\text{dBi}$
1	3	$37 - (33-3) = 7\text{dbi}$
10	3	$37 - (33-10-3) = 17\text{dbi}$

Equation (2) - Max DONOR antenna gain

Max DONOR antenna gain (dBi) = $37 - (27\text{dbi} - \text{cable losses in dbi})$.

Compliance with FCC deployment rule regarding the radiation of noise

Good engineering practice must be used in regard to the signal booster's noise radiation. Thus, the gain of the signal booster should be set so that the EIRP of the output noise from the signal booster should not exceed the level of -43 dBm in 10 kHz measurement bandwidth.

In the event that the noise level measured exceeds the aforementioned value, the signal booster gain should be decreased accordingly.



FCC Approval Clarification

In general, the ERP of noise on a spectrum more than 1 MHz outside of the pass band should not exceed -70 dBm in a 10 kHz measurement bandwidth.

The VHF D-CSR3302 signal booster has a noise level of -60 to -70 dBm in 10 kHz measurement at 1 MHz spectrum outside the passband of the signal booster and an *in-band* noise level at around -50 dBm in a 10 kHz bandwidth. Therefore, the noise at the antenna input port should be calculated based on equation (3).

Equation (3) - Input Noise to service antenna

Input Noise to service antenna:

$-50 \text{ dBm} + \text{Service Antenna gain} - \text{Antenna splitter losses in dBi} - \text{cable loss in dB}$

Example:

Signal booster connected to 10 service antennas with a 100m long ½ inch cable.

Losses of such a cable with the connectors = ~ 7dB

Gain = ~ 2 dBi

Assuming 10 service antennas: antenna splitter losses = 11 dB

Based on equation (3) Input the In-Band antenna noise (to the antenna) = $-50+2 -7 -11=-66 \text{ dBm}$

NOTE: In normal practice the antenna duplexing filter would provide -10 to -20dB attenuation at 1MHz from the band edge and the -70dBm out of band value would be easily met. However in lower loss DAS distribution systems it may be necessary to add further filtering to ensure that the -70dBm is met.

Conclusion:

Good engineering practice requires that in general when the out of band noise measured at the service antenna input is more than -70 dBm per 10 kHz measurement bandwidth, an external band pass filter should be added to attenuate the out of band noise level.



Antenna Specifications and Installation Criteria

WARNING!!!

- The installer is held accountable for implementing the rules required for deployment.
 - Good engineering practice must be used to avoid interference.
 - Output power should be reduced to solve any IMD interference issues.
-

This chapter provides information on the specifications of the donor and service antennas suitable for operation with this repeater, and on the installation requirements of the antennas.

NOTE: The Donor and Mobile antennas can be positioned and installed (without connection to the Repeater) at any time either before or after mounting and grounding the Repeater.

Base (Donor) Antenna

The Base (Donor) antenna is usually installed outdoors and is either a directional antenna such as a Yagi or a Panel antenna.

Required Antenna Information

You will require the following antenna information:

- Antenna type and characteristics
- Height
- Length and type of coaxial cable required for connecting the Donor antenna to the Repeater and the attenuation.

Donor Antenna specifications

- Max DONOR antenna gain (dBi) = 37 – (27dbi - cable losses in dbi).
- Very sharp beam pointed to the BTS.
- Minimum cable and jumper loss = 2dB.

Installation Criteria

- Select a location for the Donor antenna and verify that there is enough signal strength at that location.
- Install the Donor Antenna at the designated height.
- The antenna should point to the direction of the base station for maximum input power.
- Verify that the antenna is in the base stations line of sight (raise the antenna if necessary).
- Install the donor antenna at a higher level (i.e. floor) than the mobile antenna.



Service Antenna Requirements



WARNING!!!

- a. The installer is held accountable for implementing the rules required for deployment.
- b. Good engineering practice must be used to avoid interference.
- c. Output power should be reduced to solve any IMD interference issues”

The Service antenna type depends on the design of the indoors DAS.

Required Antenna Information

The following antenna requirements, specifications and site considerations should be met:

- Type of installation – indoor DAS/Radiating Cable
- Service area type and size
- Antenna type and characteristics
- Height
- Length and type of coaxial cable required for connecting the antenna to the Repeater and the attenuation.

Indoor Installations

Recommended Antennas

The following describes the requirements for an omni-directional mobile used for indoor applications.

Specifications:

One or a combination of the following antennas can be used: Ceiling Mount Patch antenna, Wall Mount Patch antenna, Corner Reflector.

Choose an antenna with high side lobe attenuation which enables maximum isolation from the service/mobile antenna.

Maximum Antenna Gain = 37 – (33dbi – # of antennas in dbi – cable losses in dbi).

Installation Criteria

Determine the antenna installation configuration, according to the transmission requirements and the installation site conditions.

Installation requirements:

- An indoor antenna should be installed at a convenient location. It should be free of metallic obstruction.
- Install the Service Antenna at the designated height and tune it roughly toward the Service coverage area.

Appendix E:

Photographs and Figures

The following photographs were taken of the test samples:

1. Radiated electric field emissions arrangement: front view.
2. Radiated electric field emissions arrangement: close up.

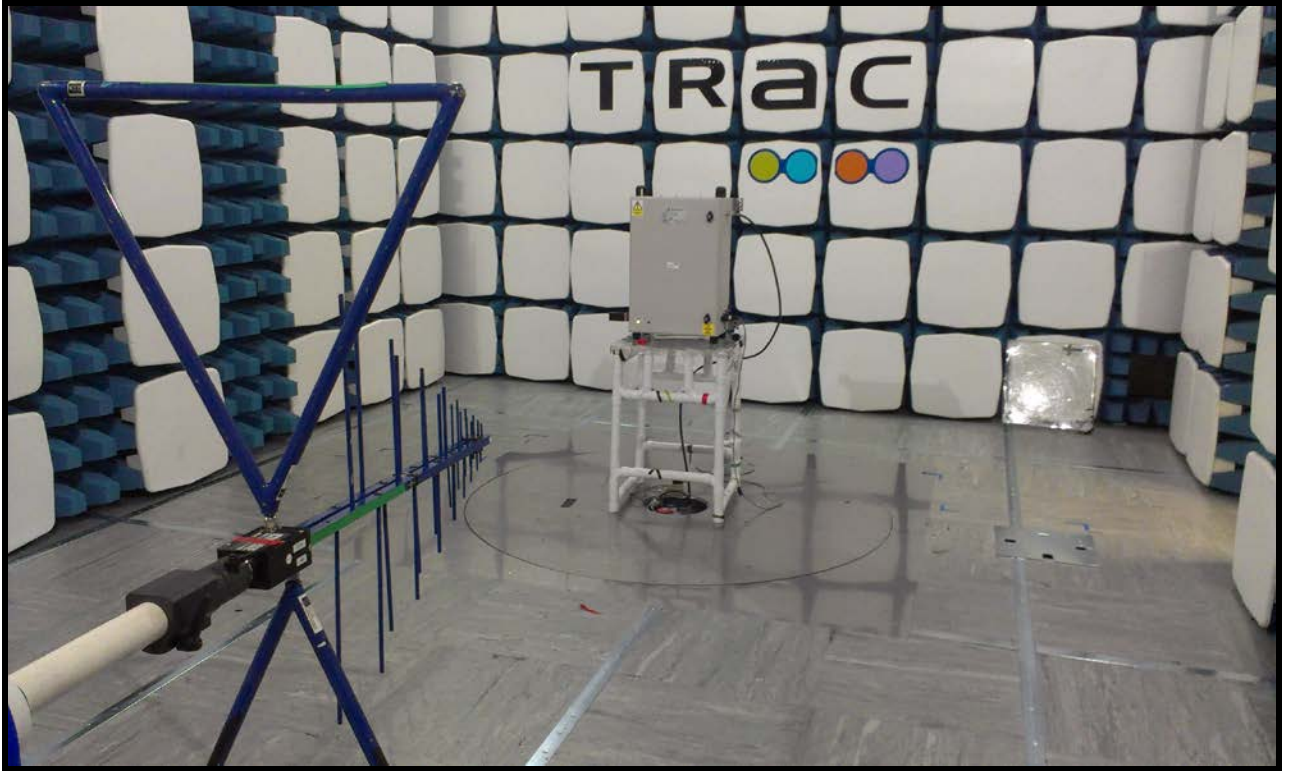

Photograph 1



Photograph 2

