



TEST REPORT NO: RU1186/6475
COPY NO: .2.....
ISSUE NO: 1
FCC ID: NE0-50-1272BDA

**REPORT ON THE CERTIFICATION TESTING OF A
AERIAL FACILITIES LIMITED
50-127202
WITH RESPECT TO
THE FCC RULES CFR 47, PART 90 Subpart I
PRIVATE LAND MOBILE REPEATER.**

TEST DATE: 13th June 2005 – 14th June 2005

TESTED BY: J CHARTERS
APPROVED BY: P GREEN
PRODUCT MANAGER
EMC
DATE: 30th January 2006

Distribution:

- Copy Nos:
1. Aerial Facilities Limited
 2. TCB: TRL Compliance Limited
 3. TRL EMC

THIS DOCUMENT MAY BE REPRODUCED ONLY IN ITS ENTIRETY AND WITHOUT CHANGE

CONTENTS

	PAGE	
CERTIFICATE OF CONFORMITY & COMPLIANCE	3	
APPLICANT'S SUMMARY	4	
EQUIPMENT TEST CONDITIONS	5	
TESTS REQUIRED	5	
TEST RESULTS	6-39	
		ANNEX
PHOTOGRAPHS		A
PHOTOGRAPH No. 1: Test setup		
PHOTOGRAPH No. 2: Test setup		
APPLICANT'S SUBMISSION OF DOCUMENTATION LIST		B
TEST EQUIPMENT CALIBRATION		C
MEASUREMENT UNCERTAINTY		D
SYSTEM DIAGRAM		E
Notes:		
1. Component failure during test	YES	<input type="checkbox"/>
	NO	<input checked="" type="checkbox"/>
2. If Yes, details of failure:		
3. The facilities used for the testing of the product contain in this report are FCC Listed.		

CERTIFICATE OF CONFORMITY & COMPLIANCE

FCC IDENTITY:	NE0-50-1272BDA
PURPOSE OF TEST:	Certification
TEST SPECIFICATION:	FCC RULES CFR 47, Part 90 Subpart I
TEST RESULT:	Compliant to Specification
EQUIPMENT UNDER TEST:	50-127202
EQUIPMENT TYPE:	Private Land Mobile Repeater
MAXIMUM GAIN	Uplink = 38.0 dB Downlink = 33.70 dB
MAXIMUM INPUT	Uplink = -5.5dBm Downlink = +2.5dBm
MAXIMUM OUTPUT	Uplink = +32.5dBm Downlink = +36.2 dBm
ANTENNA TYPE:	Not applicable
CHANNEL SPACING:	Not applicable
FREQUENCY GENERATION:	Not applicable
MODULATION TYPE:	F3E
POWER SOURCE(s):	110Vac or +24Vdc
TEST DATE(s):	13 th June 2005 – 14 th June 2005
ORDER No(s):	31251
APPLICANT:	Aerial Facilities Limited
ADDRESS:	Aerial House Asheridge Road Chesham Buckinghamshire HP5 2QD United Kingdom
TESTED BY:	----- J CHARTERS
APPROVED BY:	----- P GREEN PRODUCT MANAGER EMC

EQUIPMENT TEST / EXAMINATIONS REQUIRED

1.	TEST/EXAMINATION	RULE PART	APPLICABILITY	RESULT
	RF Power Output	90.205	Yes	Complies
	Audio Frequency Response	TIA EIA-603.3.2.6	N/A	N/A
	Audio Low-Pass Filter Response	TIA EIA-603.3.2.6	N/A	N/A
	Modulation Limiting	TIA EIA-603.3.2.6	N/A	N/A
	Occupied Bandwidth	90.210	Yes	Complies
	Spurious Emissions at Antenna Terminals	90.210	Yes	Complies
	Field Strength of Spurious Emissions	90.210	Yes	Complies
	Frequency Stability	90.213	N/A(note 1)	N/A
	Transient behaviour	90.214	N/A(note 2)	N/A

Notes:

1 The EUT does not contain modulation circuitry, therefore the test was not performed.

2 The EUT is not a keyed carrier system, therefore the test was not performed.

- | | | | | |
|-----|--|----------------------------------|---------------------|-------------|
| 2. | Product Class: | Uplink | Class A [] | Class B [X] |
| | | Downlink | Class A [] | Class B [X] |
| 3. | Product Use: | Private Land Mobile Repeater | | |
| 4. | Emission Designator: | F3E | | |
| 5. | Temperatures: | Ambient (Tnom) | 24°C | |
| 6. | Supply Voltages: | Vnom | 110Vac or
+24Vdc | |
| | Note: Vnom voltages are as stated above unless otherwise shown on the test report page | | | |
| 7. | Equipment Category: | Single channel | [] | |
| | | Two channel | [] | |
| | | Multi-channel | [X] | |
| 8. | Channel spacing: | Narrowband | [] | |
| | | Wideband | [X] | |
| 9. | Test Location | TRL Compliance Limited | | |
| | | Up Holland | [X] | |
| | | Long Green | [] | |
| 10. | Modifications made during test program | No modifications were performed. | | |

System Description:

The 50-127202 is Bi directional amplifier consisting of an uplink and a downlink. The uplink operates in the frequency band 137.0 – 143.0 MHz. The uplink is wideband. The downlink operates in the frequency band 154.25 – 155.75 MHz. The downlink is wideband. The 50-127201 is incorporated into a system as shown in Annex E.

COMPLIANCE TESTS

AMPLIFIER GAIN – CONDUCTED – PART 2.1046 – UPLINK

Ambient temperature = 24°C
 Relative humidity = 41%
 Supply voltage = 110Vac or +24Vdc
 Channel number = See test results

Radio Laboratory

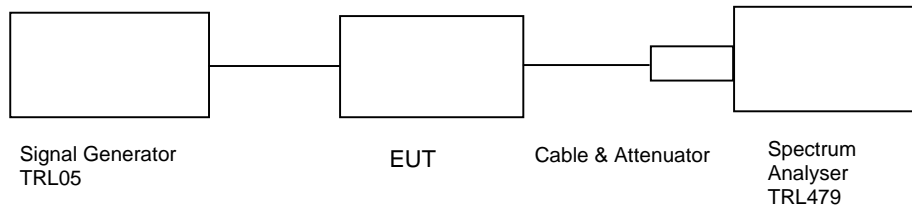

Frequency MHz	Voltage	Signal Generator input level dBm	Cable & Attenuator loss dB	Level at Spectrum Analyser dBm	Gain dB	Output Power dBm	Gain after 10dB input level increase dBm
137.0 MHz	110Vac	-4	35.91	-3.27	36.64	32.64	27.23
140.0 MHz	110Vac	-5.5	35.91	-3.44	37.97	32.47	29.02
143.0 MHz	110Vac	-4	35.91	-3.00	36.91	32.91	27.52
137.0 MHz	24Vdc	-4	35.91	-3.20	36.71	32.71	26.79
140.0 MHz	24Vdc	-5.5	35.91	-3.41	38.00	32.50	27.01
143.0 MHz	24Vdc	-4	35.91	-3.01	36.90	32.90	27.52

Notes:

1. The level of the signal generator takes into consideration the loss from the cable.
2. The signal generator input was increased by 10dBs and the level of the output signal remeasured

TYPE OF EQUIPMENT	MAKER/SUPPLIER	MODEL No	SERIAL No	TRL No	ACTUAL EQUIPMENT USED
SPECTRUM ANALYSER	ANRITSU	MS2665C	MT26089	479	X
ATTENUATOR	BIRD	8304-300-N	N/A	220	X
ATTENUATOR	BIRD	8304-100-N	N/A	222	X
CABLE	ROSENBERGER	MICRO COAX	N/A	280	X
CMTA	RHODE & SCHWARZ	CMTA52	894715/003	05	X

AMPLIFIER INTERMODULATION SPURIOUS EMISSIONS – CONDUCTED – PART 2.1053– UPLINK

Ambient temperature = 25°C
 Relative humidity = 41%
 Supply voltage = 110Vac or +24Vdc

Radio Laboratory

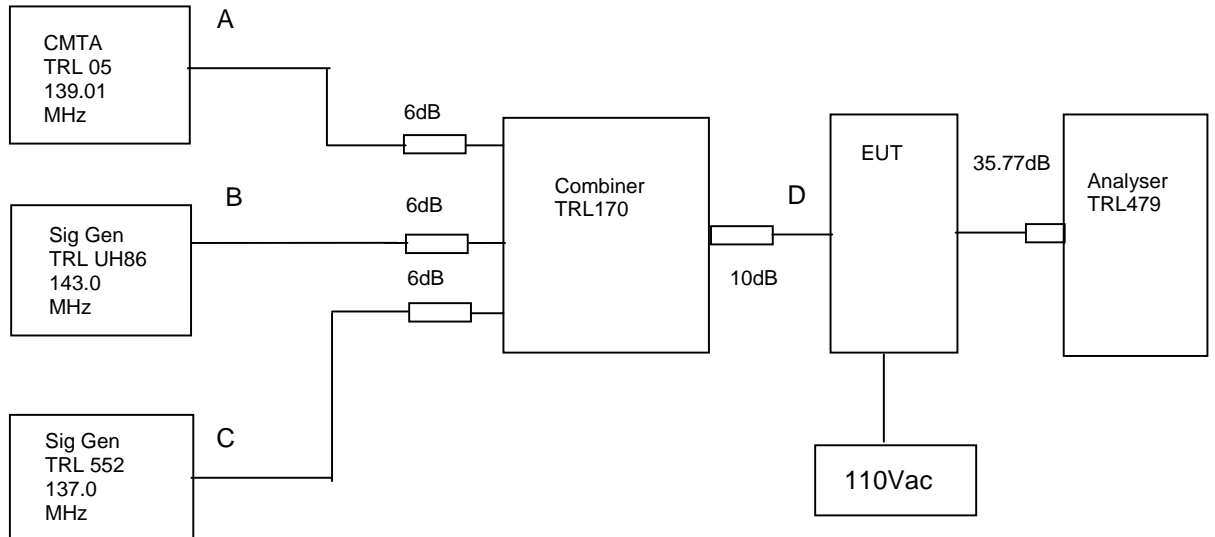

The Intermodulation and spurious products were measured with the amplifier operating at maximum gain. A three tone test was conducted using the equipment as above. The input power level was adjusted so the level at point D was 10 dB above the maximum input of -4.5dBm. The cable and attenuator loss between the EUT and the spectrum analyser was 35.77dB.

RF Input Frequency (MHz)			Highest Intermodulation Product Level (dBm)	Limit (dBm)
137.00	139.01	143.00	-13.22 dBm @ 141.005 MHz	-13

Sweep data is shown on the next page:

Test equipment used for Intermodulation test

TYPE OF EQUIPMENT	MAKER/SUPPLIER	MODEL No	SERIAL No	TRL No	ACTUAL EQUIPMENT USED
SPECTRUM ANALYSER	ANRITSU	MS2665C	MT26089	479	X
SIGNAL GENERATOR	MARCONI	2022	119562/02	UH89	X
CMTA	ROHDE & SCHWARZ	CMTA52	894715/033	05	X
SIGNAL GENERATOR	HP	8341B	2819A02239	552	X
COMBINER	ELCOM	RC-4-50	N/A	170	X
Power Amp	ENI	603L-1471	15789F	L031	X

Intermodulation Inband

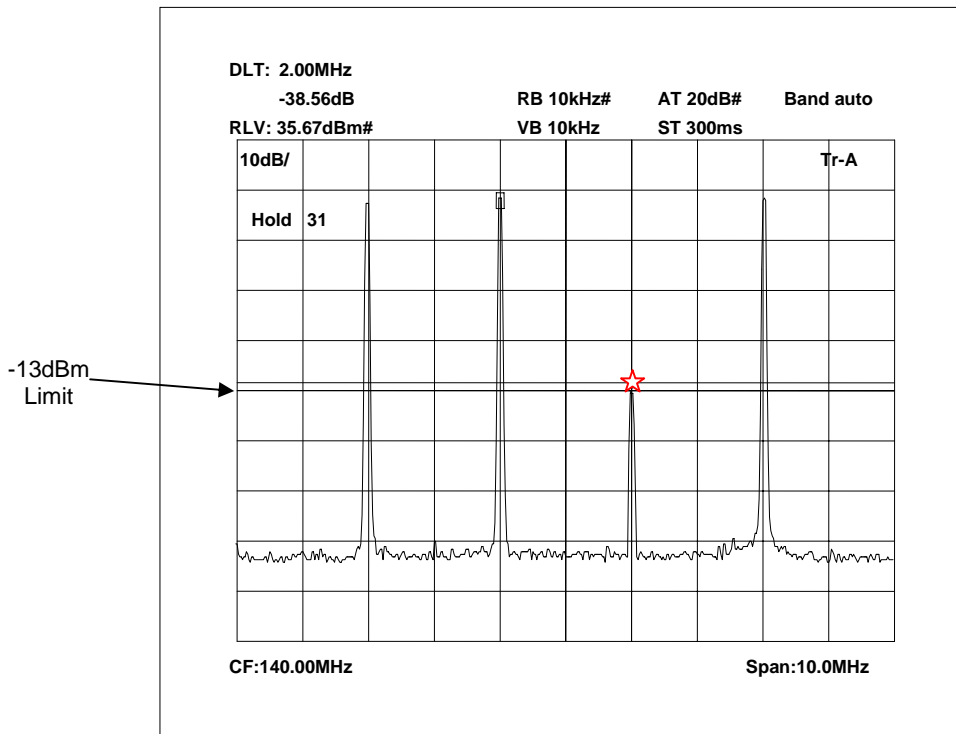

The above plot shows that all products (designated by ☆) are at least 40dB below the fundamentals.

Intermodulation Wideband

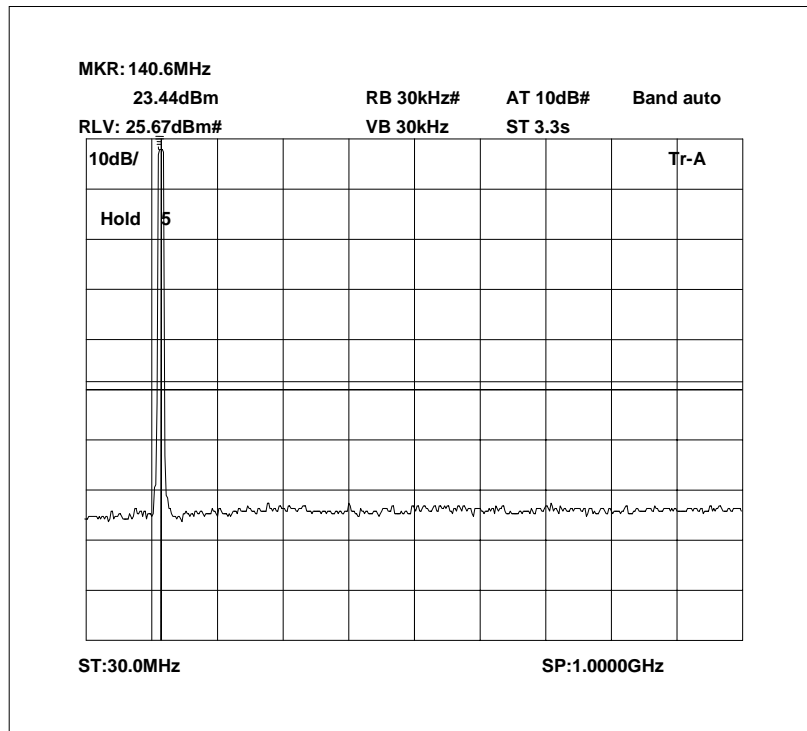

The above plot shows that there are no products outside the bands.

TRANSMITTER TESTS

AMPLIFIER MODULATED CHANNEL TEST – CONDUCTED – Part 2.1049– UPLINK

Ambient temperature = 24°C
 Relative humidity = 40%
 Supply voltage = 110Vac or +24Vdc
 Channel number = See test results

Radio Laboratory

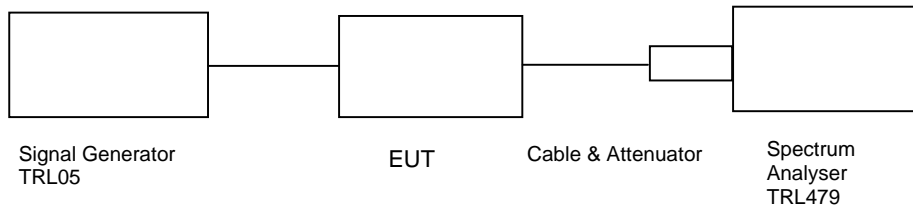

This test was performed to show that the amplifier does not alter the input signal in any way. The input signal was set to the maximum input level (-4dBm) and modulated with a 2500Hz tone. The plots show the signal measured at the signal generator and the signal measured at the output of the EUT.

Note: The cables and attenuators had the following losses.

1. Cable and attenuator between EUT and analyser 35.77dB
2. Cable between signal generator and EUT 0.14dB

TYPE OF EQUIPMENT	MAKER/SUPPLIER	MODEL No	SERIAL No	TRL No	ACTUAL EQUIPMENT USED
SPECTRUM ANALYSER	ANRITSU	MS2665C	MT26089	479	X
ATTENUATOR	BIRD	8304-300-N	N/A	220	X
ATTENUATOR	BIRD	8304-100-N	N/A	222	X
CABLE	ROSENBERGER	MICRO COAX	N/A	280	X
CMTA	RHODE & ACHWARZ	CMTA52	894715/003	05	X

137.0 MHz Signal Generator, deviation set to 5kHz

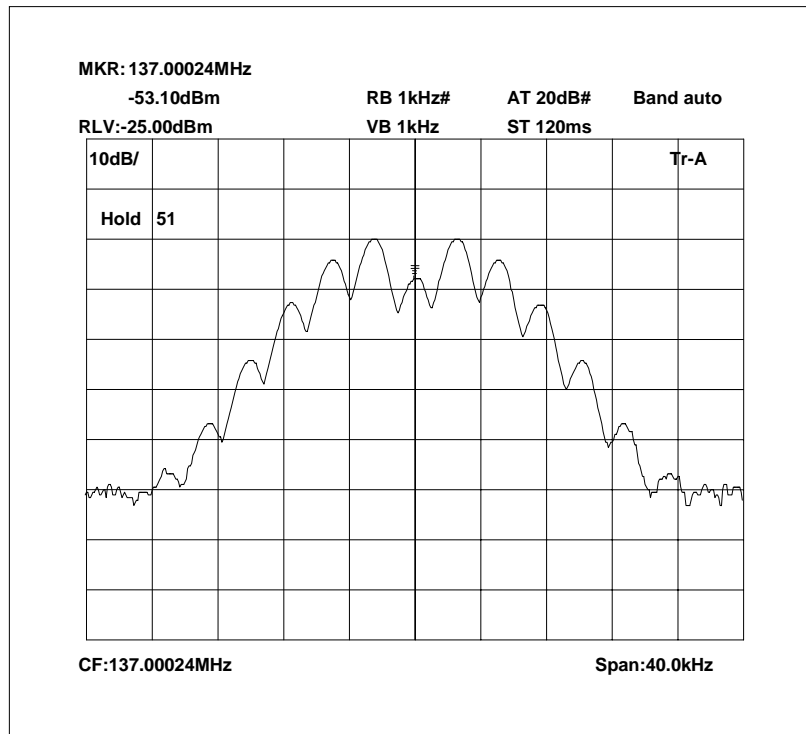

137.0 MHz Signal Generator and EUT, deviation set to 5kHz

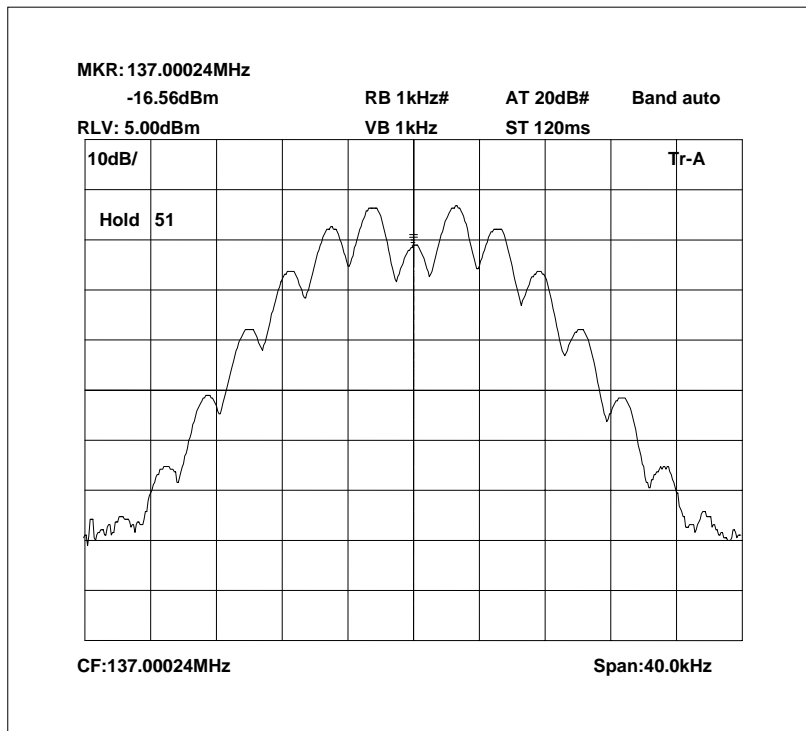

The above plots depicting the output waveshape show no measurable distortion visible when compared to the input signal.

140.0 MHz Signal Generator, deviation set to 5kHz

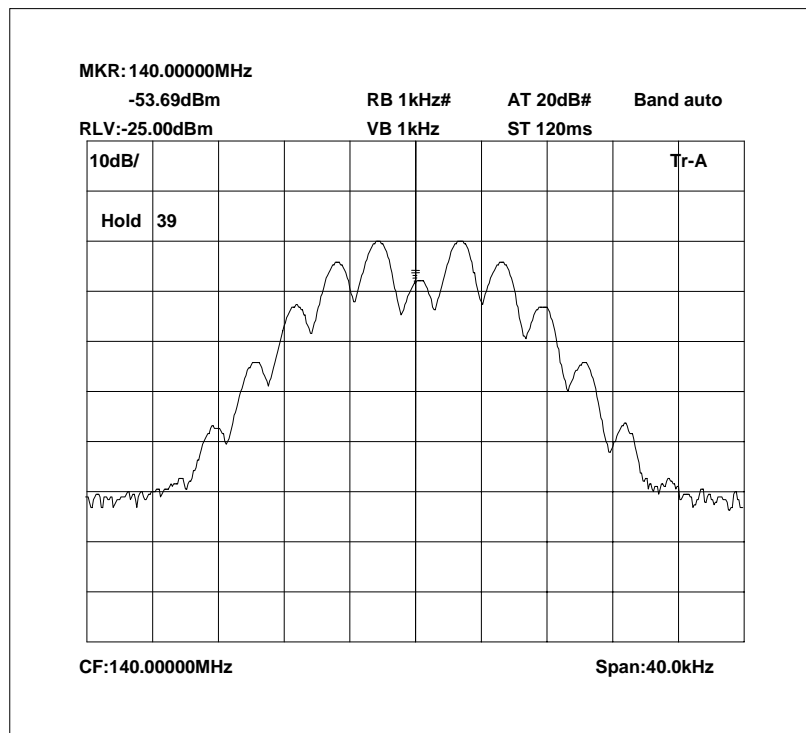

140.0 MHz Signal Generator and EUT, deviation set to 5kHz

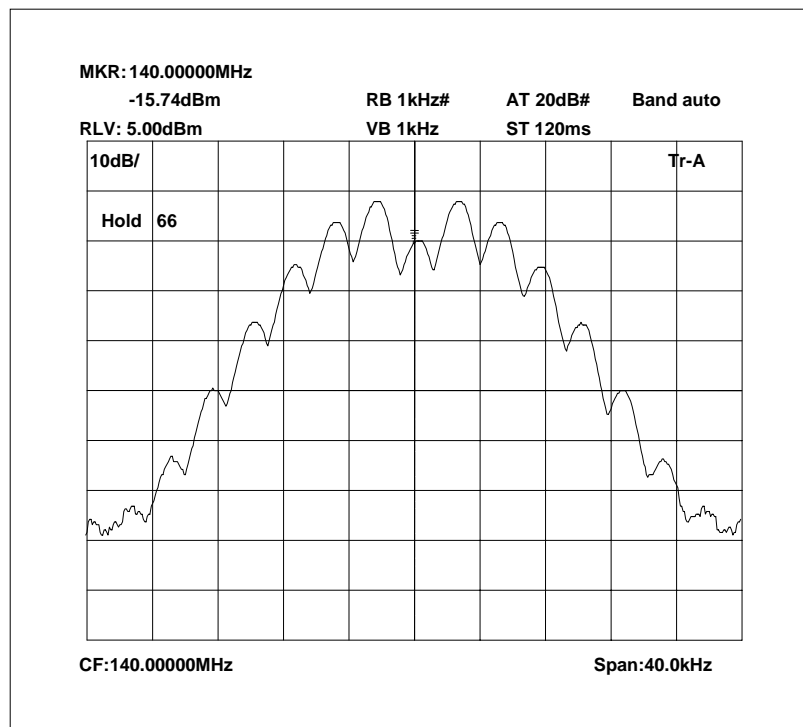

The above plots depicting the output waveshape show no measurable distortion visible when compared to the input signal.

143.0 MHz Signal Generator, deviation set to 5kHz

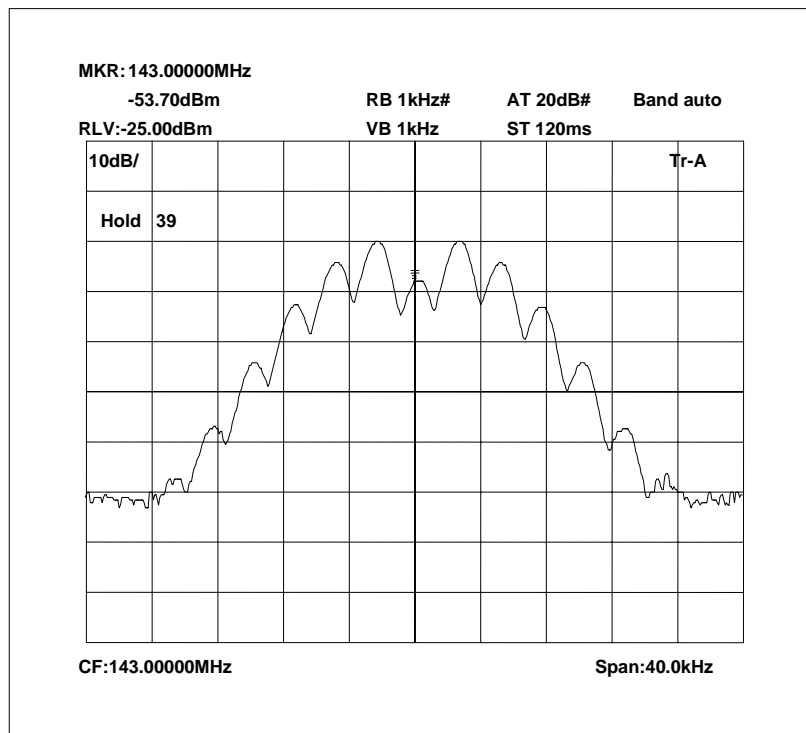

143.0 MHz Signal Generator and EUT, deviation set to 5kHz

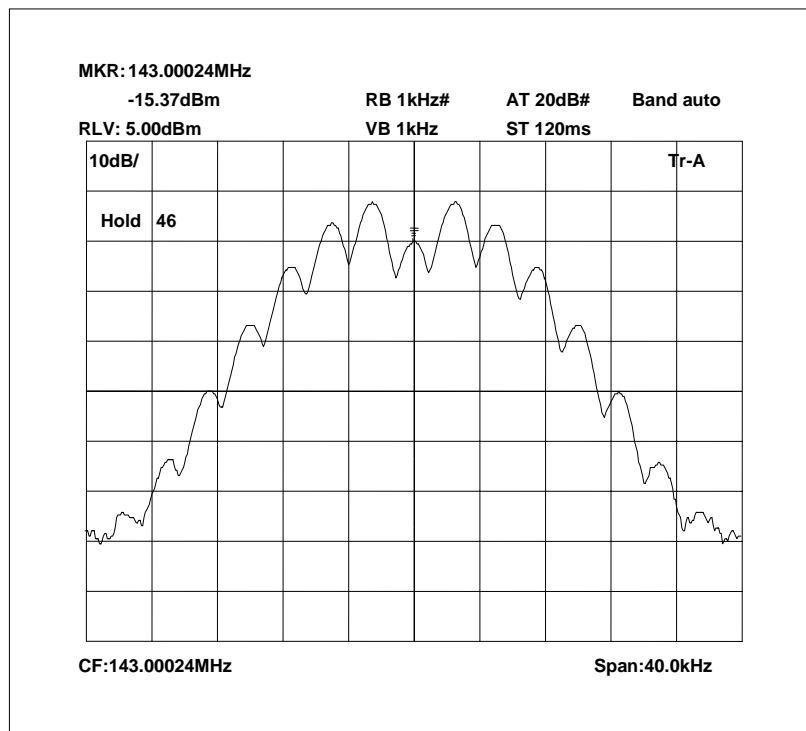

The above plots depicting the output waveshape show no measurable distortion visible when compared to the input signal.

TRANSMITTER TESTS

AMPLIFIER SPURIOUS EMISSIONS – CONDUCTED – Part 2.1053 – UPLINK

Ambient temperature = 17°C
 Relative humidity = 50%
 Supply voltage = 110Vac or +24Vdc

Radio Laboratory
 Test Signal = F3E

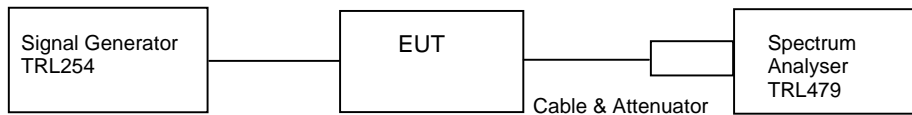

The test was set up as per the diagram. The level at the input was adjusted to compensate for the loss of the interconnecting cable. The unit was tested operating at maximum power and on three test frequencies.

The Spurious limit was calculated as follows:

On any frequency removed from the assigned frequency by more than 250% of the authorised bandwidth

At least $43 + 10 \log P_{dB}$

$$(10 \log P_{\text{watts}}) - (43 + 10 \log (P_{\text{watts}} * 1000)) = \text{LIMIT} = -13 \text{ dBm}$$

RESULTS

FREQUENCY RANGE	FREQ. (MHz)	MEASURED LEVEL (dBm)	ATTENUATOR & CABLE LOSSES (dB)	EMISSION LEVEL (dBm)	LIMIT (dBm)
0 – 2GHz	No Significant Emissions				-13

The test equipment used for the Transmitter Conducted Emissions:

TYPE OF EQUIPMENT	MAKER/SUPPLIER	MODEL No	SERIAL No	TRL No	ACTUAL EQUIPMENT USED
SPECTRUM ANALYSER	ANRITSU	MS2665C	MT26089	479	X
ATTENUATOR	BIRD	8304-300-N	N/A	220	X
ATTENUATOR	BIRD	8304-100-N	N/A	222	X
CABLE	ROSENBERGER	MICRO COAX	N/A	280	X
CMTA	ROHDE & SCHWARZ	CMTA52	894715/033	05	X

Conducted emissions 137.0 MHz 0 – 1GHz

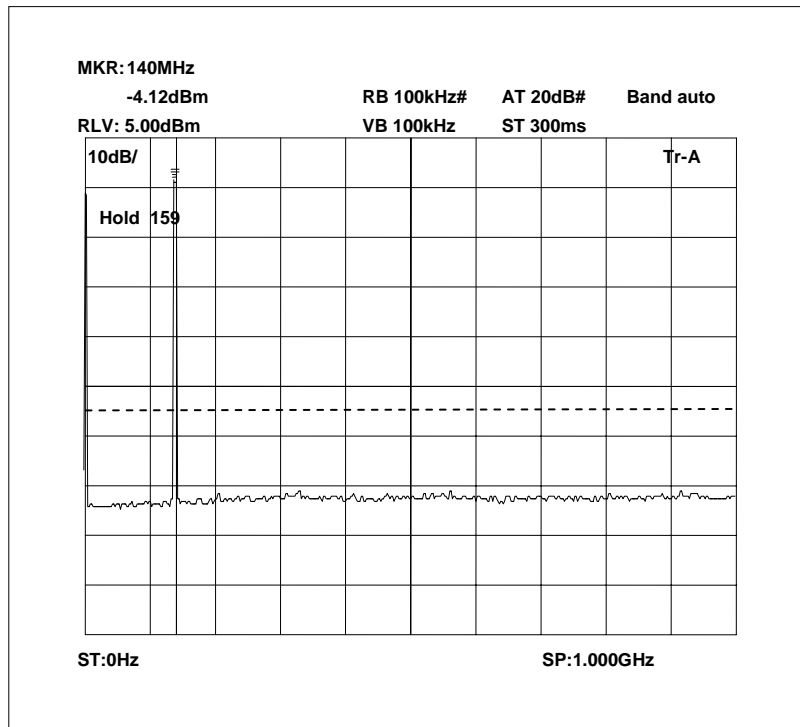

Conducted emissions 137.0 MHz 1 – 2GHz

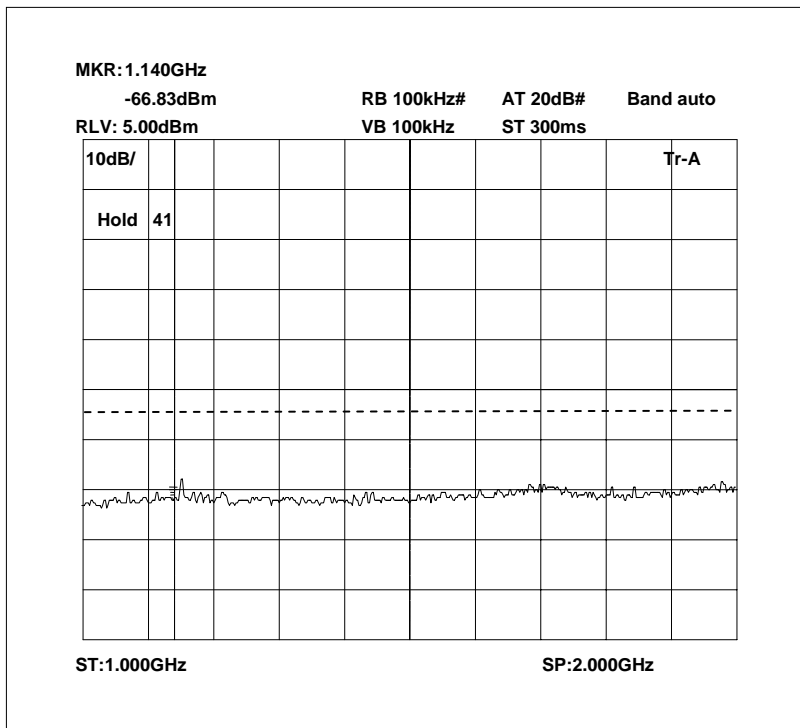

Conducted emissions 140.0 MHz 0 – 1GHz

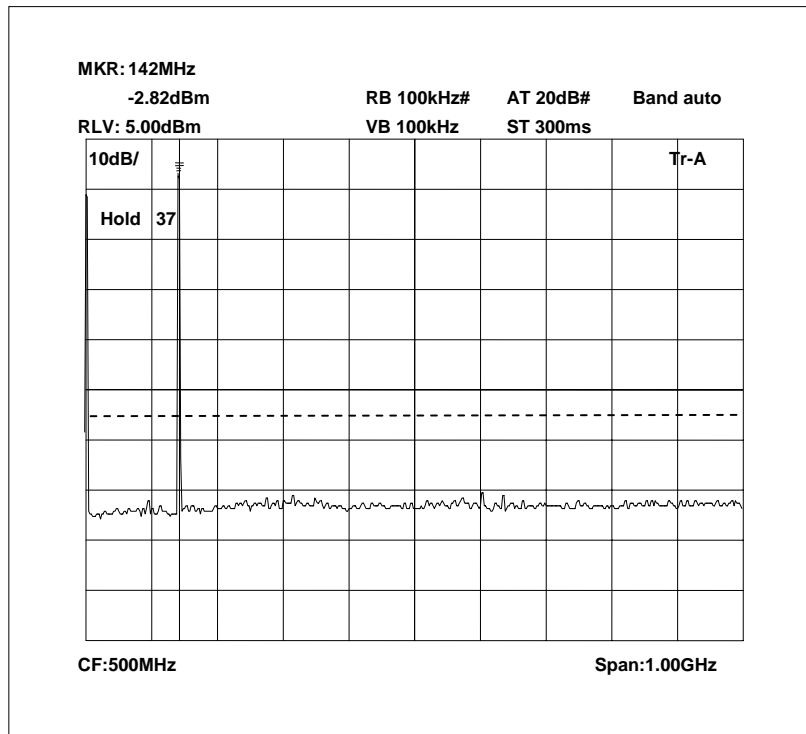

Conducted emissions 140.0 MHz 1 – 2GHz

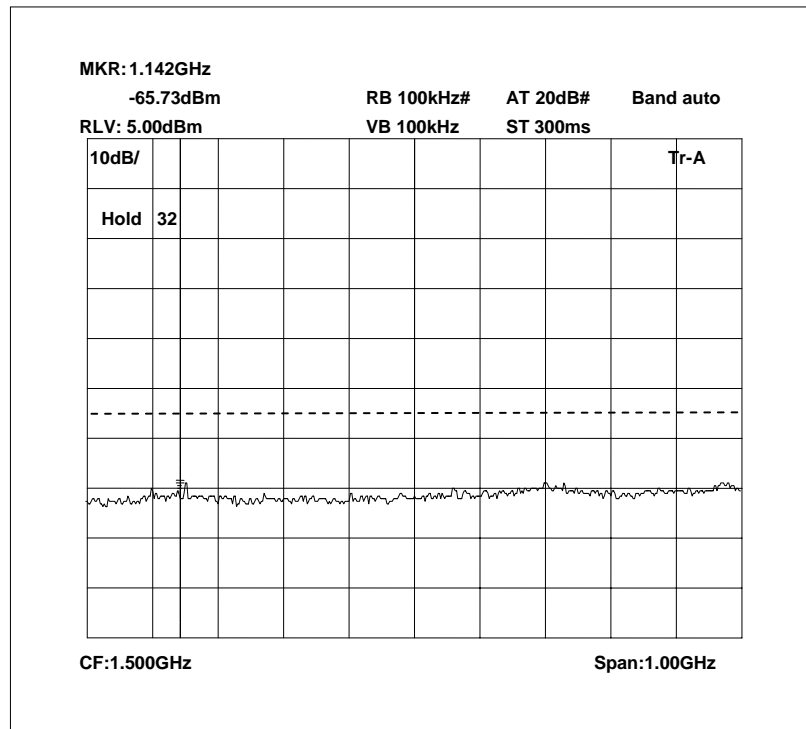

Conducted emissions 143.0 MHz 0 – 1GHz

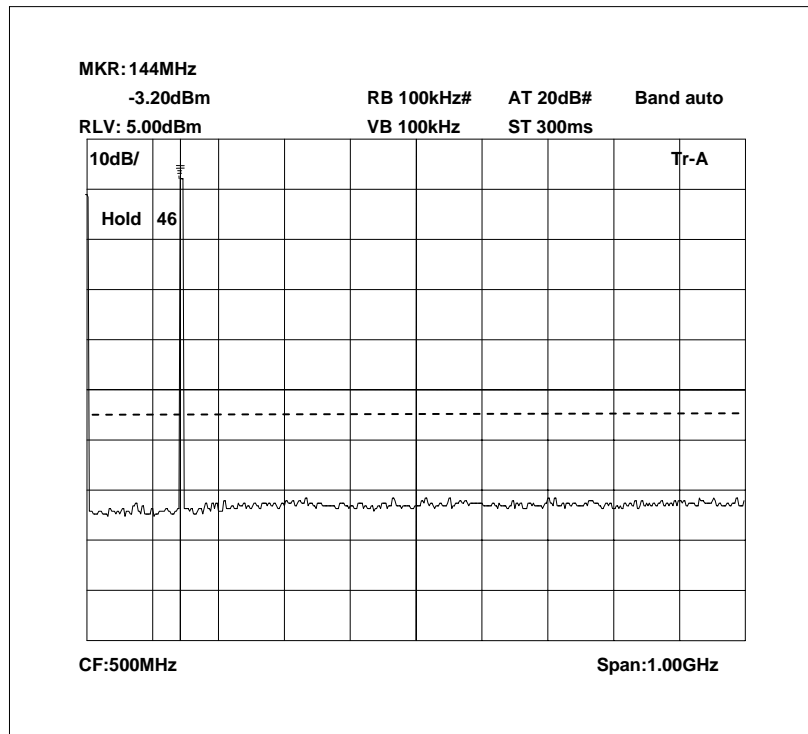

Conducted emissions 143.0 MHz 1 – 2GHz

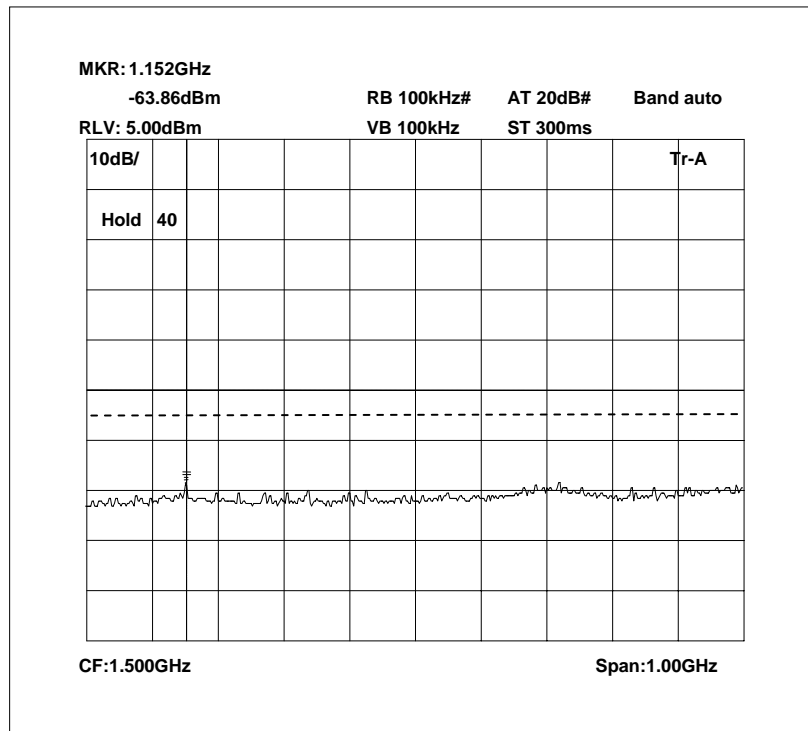

TRANSMITTER TESTS

AMPLIFIER SPURIOUS EMISSIONS – RADIATED – Part 2.1053– UPLINK

Ambient temperature = 24°C
 Relative humidity = 45%
 Conditions = OATS
 Supply voltage = 110Vac or +24Vdc
 Supply Frequency = N/A

Test Signal = F3E

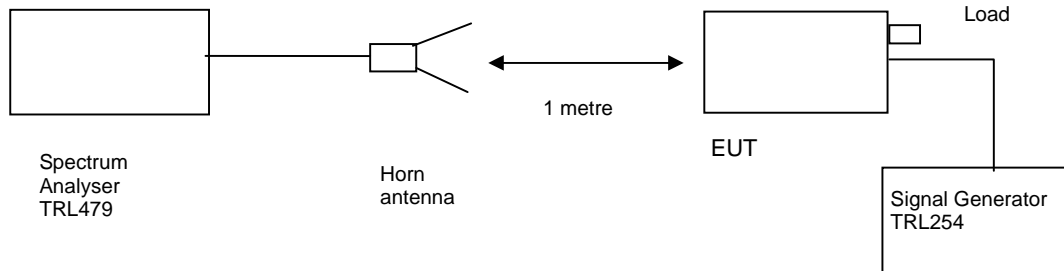

The test was set up as per the diagram. The level at the input was adjusted to compensate for the loss of the interconnecting cable. The unit was tested operating maximum power on three test frequencies with a 50 ohm load on the output. The unit was also tested with the signal generator replaced by another 50ohm load.

The Spurious limit was calculated as follows:

On any frequency removed from the assigned frequency by more that 250% of the authorised bandwidth

At least $43 + 10 \log P_{dB}$

$(10 \log P_{watts}) - (43 + 10 \log (P_{watts} * 1000)) = \text{LIMIT} = -13 \text{ dBm}$

RESULTS

FREQUENCY RANGE	FREQ. (MHz)	MEAS. Rx. (dBµV)	CABLE LOSS (dB)	ANT FACTOR	FIELD STRENGTH (dBµV/m)	CALCULATED EIRP (dBm)	LIMIT (dBm)
0 – 2 GHz	No Significant Emissions						-13

The test equipment used for the Transmitter Spurious Emissions:

TYPE OF EQUIPMENT	MAKER/SUPPLIER	MODEL No	SERIAL No	TRL No	ACTUAL EQUIPMENT USED
SPECTRUM ANALYSER	ANRITSU	MS2665C	MT26089	479	X
HORN	EMCO	3115	9010-3581	139	X
ATTENUATOR	BIRD	8304-300-N	N/A	220	X
CABLE	ROSENBERGER	MICRO COAX	N/A	280	X
SIGNAL GENERATOR	MARCONI	2042	119562/021	254	X

Radiated emissions 137.0 MHz 0 – 1GHz

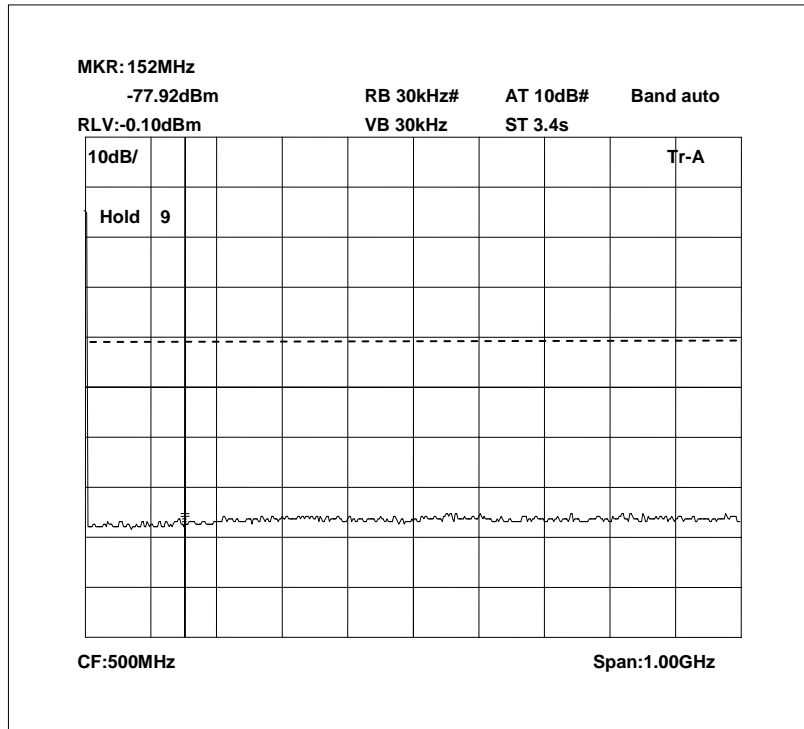

Radiated emissions 137.0 MHz 1 – 2GHz

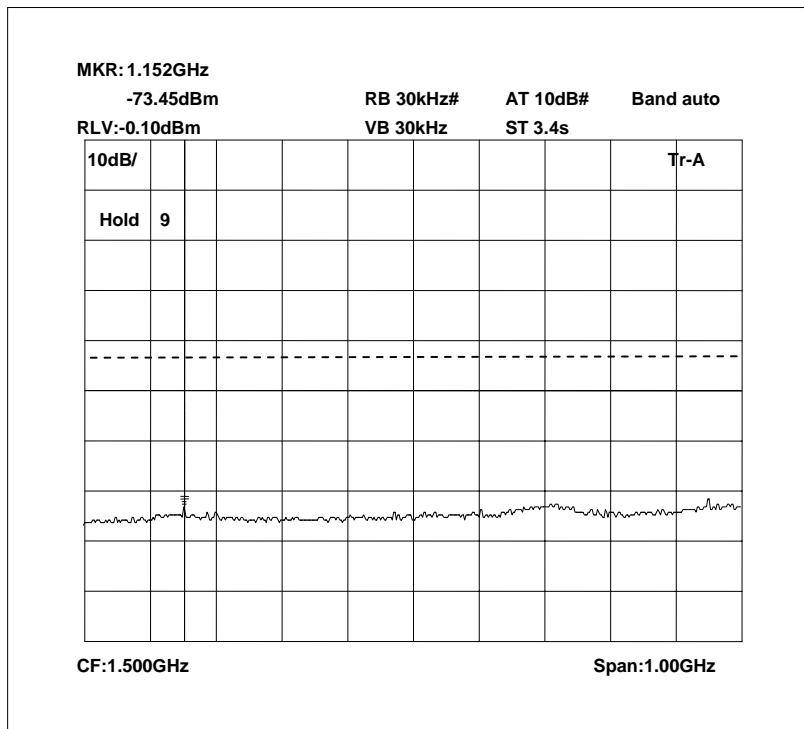

The above test results show that there were no emissions within 20dBs of the -13dBm limit.

Radiated emissions 140.0 MHz 0 – 1GHz

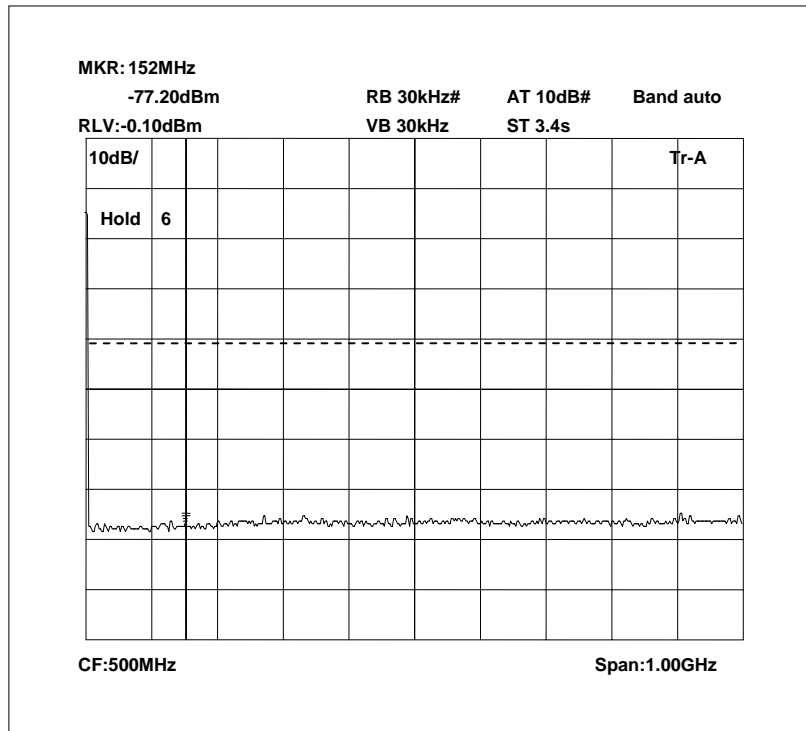

Radiated emissions 140.0 MHz 1 – 2GHz

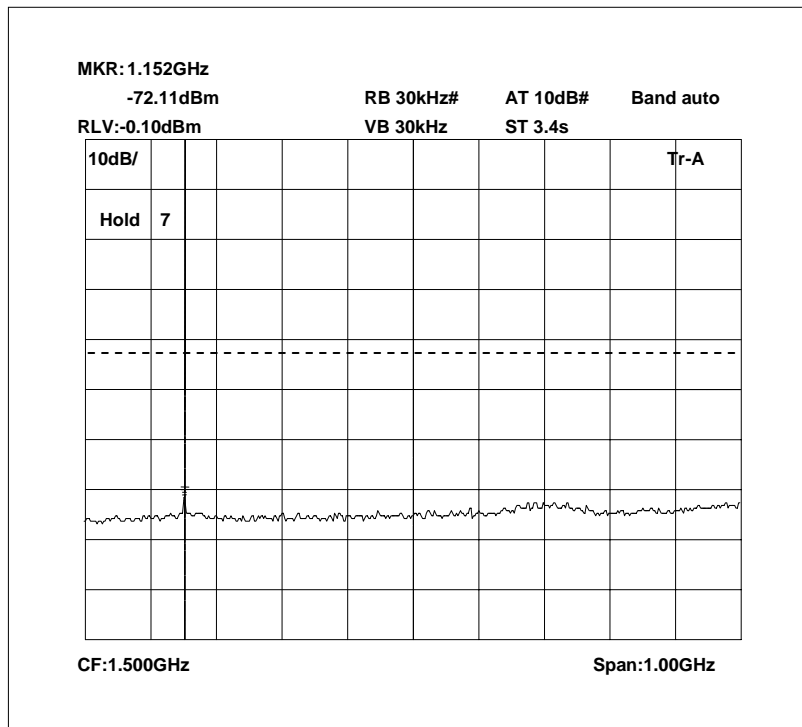

The above test results show that there were no emissions within 20dBs of the -13dBm limit.

Radiated emissions 143.0 MHz 0 – 1GHz

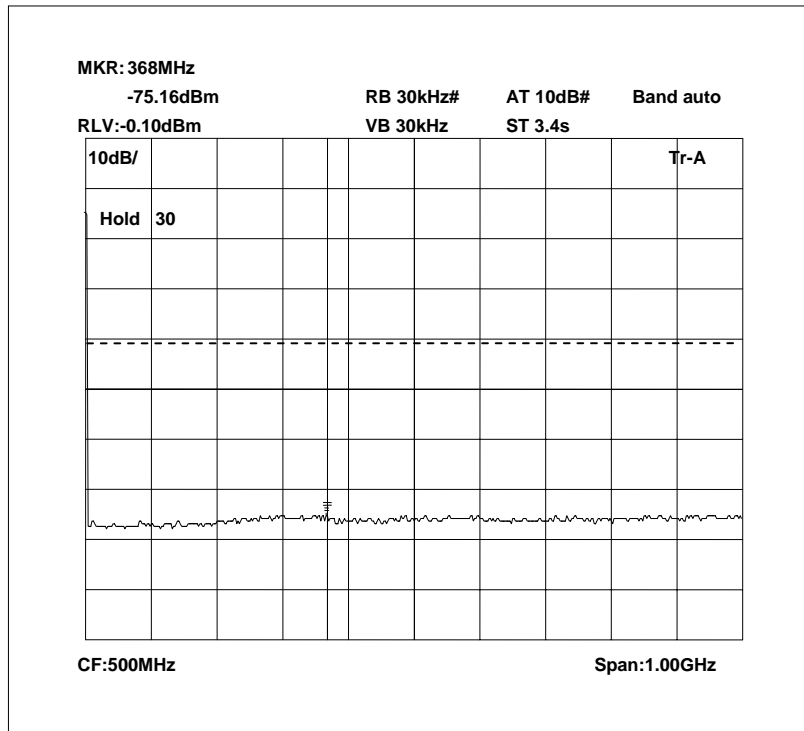

Radiated emissions 143.0 MHz 1 – 2GHz

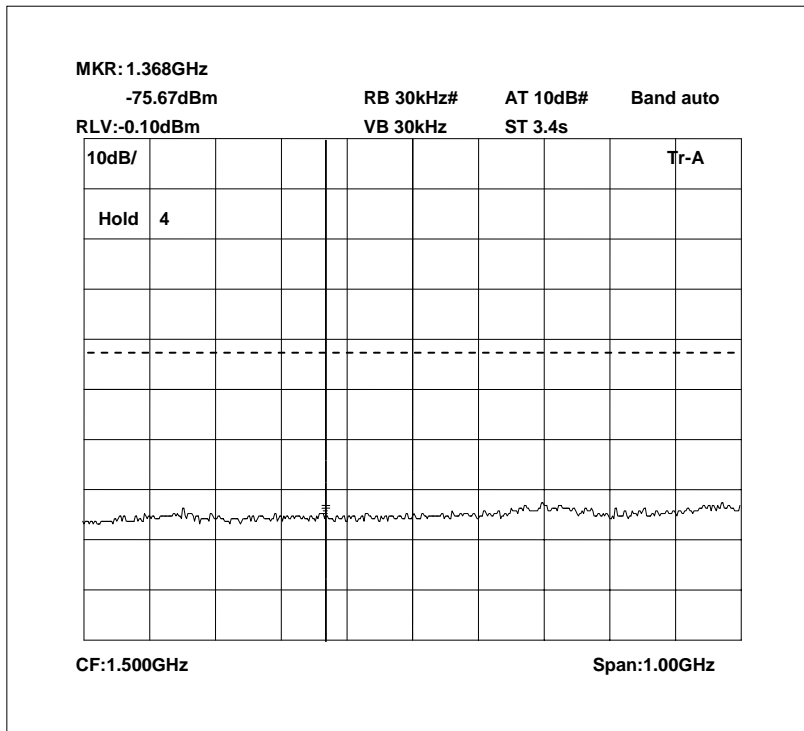

The above test results show that there were no emissions within 20dBs of the -13dBm limit.

Radiated emissions no input signal 0 – 1GHz

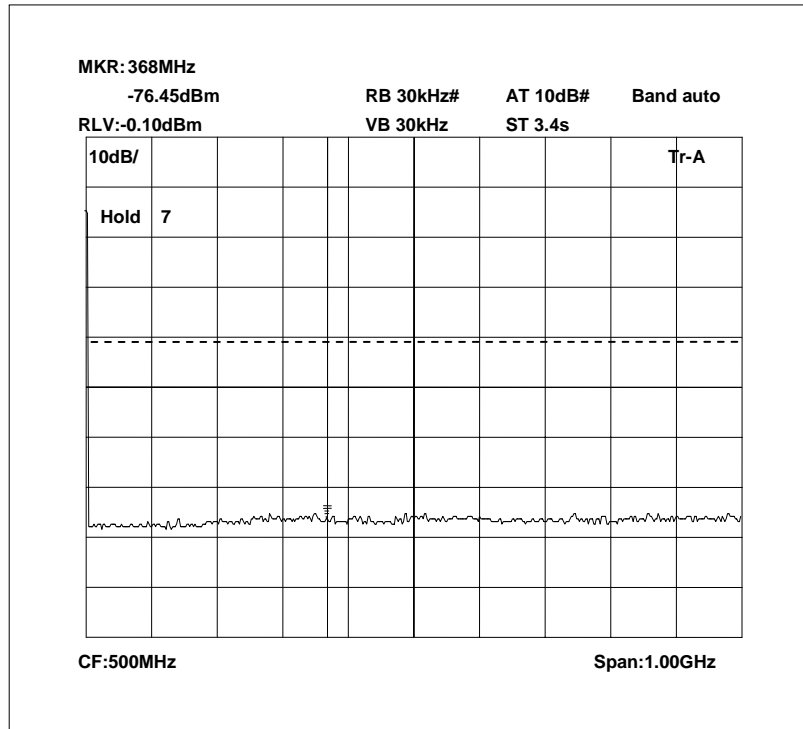

Radiated emissions no input signal 1 – 2GHz

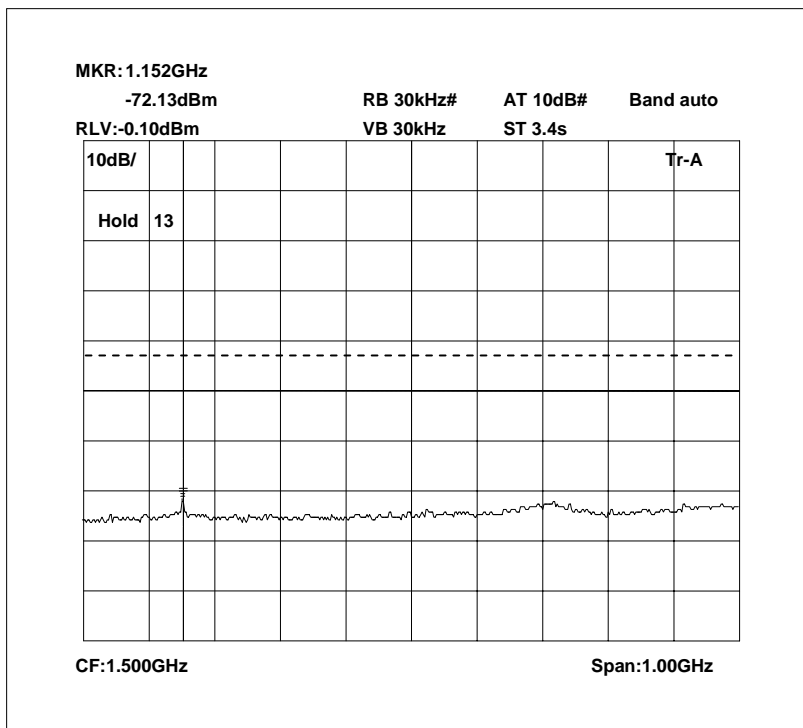

The above test results show that there were no emissions within 20dBs of the -13dBm limit.

AMPLIFIER GAIN – CONDUCTED – PART 2.1046 – DOWNLINK

Ambient temperature = 27°C
 Relative humidity = 36%
 Supply voltage = 110Vac or +24Vdc
 Channel number = See test results

Radio Laboratory

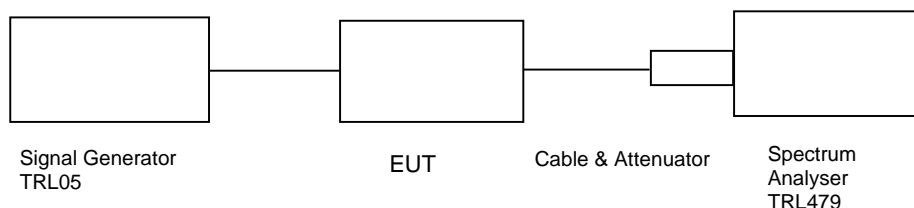

Frequency MHz	Voltage	Signal Generator input level dBm	Cable & Attenuator loss dB	Level at Spectrum Analyser dBm	Gain dB	Output Power dBm	Gain after 10dB input level increase dBm
154.0 MHz	110Vac	3.0	36.44	0.07	33.51	36.51	24.36
155.0 MHz	110Vac	2.5	36.44	-0.24	33.70	36.20	24.67
156.0 MHz	110Vac	1.5	36.44	-1.32	33.62	35.12	24.64
154.0 MHz	24Vdc	3.0	36.44	-0.11	33.33	36.33	24.45
155.0 MHz	24Vdc	2.5	36.44	-0.39	33.55	36.05	24.77
156.0 MHz	24Vdc	1.5	36.44	-1.52	33.42	34.92	24.52

Notes:

1. The level of the signal generator takes into consideration the loss from the cable.
2. The signal generator input was increased by 10dBs and the level of the output signal remeasured

TYPE OF EQUIPMENT	MAKER/SUPPLIER	MODEL No	SERIAL No	TRL No	ACTUAL EQUIPMENT USED
SPECTRUM ANALYSER	ANRITSU	MS2665C	MT26089	479	X
ATTENUATOR	BIRD	8304-300-N	N/A	220	X
ATTENUATOR	BIRD	8304-100-N	N/A	222	X
CABLE	ROSENBERGER	MICRO COAX	N/A	280	X
SIGNAL GENERATOR	RHODE & ACHWARZ	CMTA	894715/003	05	X

AMPLIFIER INTERMODULATION SPURIOUS EMISSIONS – CONDUCTED – PART 2.1053– DOWNLINK

Ambient temperature = 21°C
 Relative humidity = 45%
 Supply voltage = 110Vac or +24Vdc

Radio Laboratory

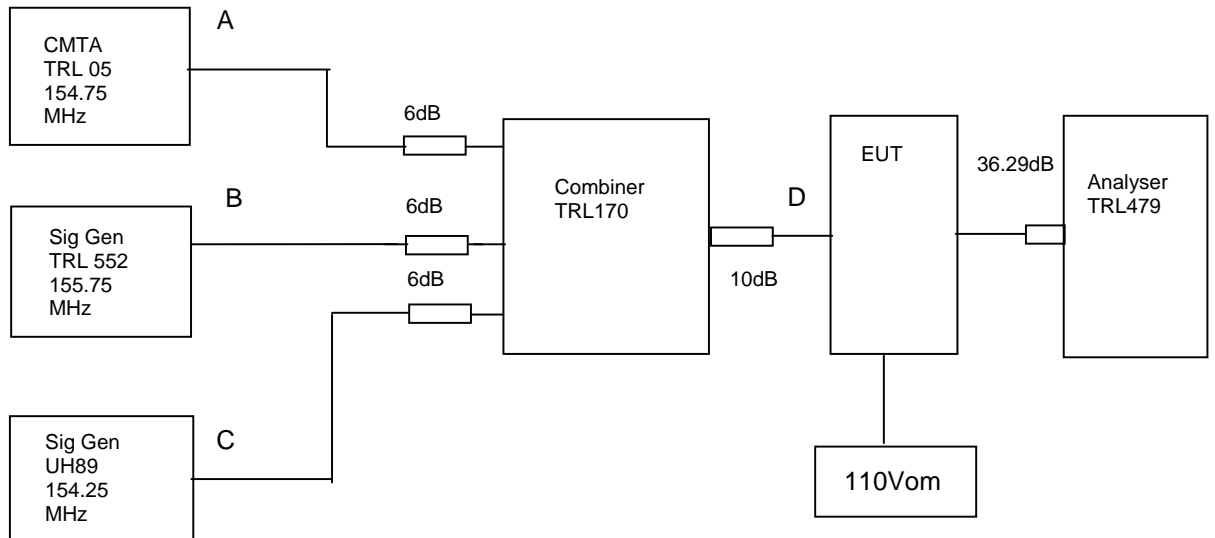

The Intermodulation and spurious products were measured with the amplifier operating at maximum gain. A three tone test was conducted using the equipment as above. The input power level was adjusted so the level at point D was 10dB above the maximum input of +3dBm. The cable and attenuators loss between the EUT and the spectrum analyser was 36.29 dB.

RF Input Frequency (MHz)			Highest Intermodulation Product Level (dBm)	Limit (dBm)
154.25	154.75	155.75	-13.12 dBm @ 155.25MHz	-13

Sweep data is shown on the next page:

Test equipment used for Intermodulation test

TYPE OF EQUIPMENT	MAKER/SUPPLIER	MODEL No	SERIAL No	TRL No	ACTUAL EQUIPMENT USED
SPECTRUM ANALYSER	ANRITSU	MS2665C	MT26089	479	X
SIGNAL GENERATOR	MARCONI	2022	119562/02	UH89	X
CMTA	ROHDE & SCHWARZ	CMTA52	894715/033	05	X
SIGNAL GENERATOR	HP	8341B	2819A02239	552	X
COMBINER	ELCOM	RC-4-50	N/A	170	X
Power Amp	ENI	603L-1471	15789F	L031	X

Intermodulation Inband

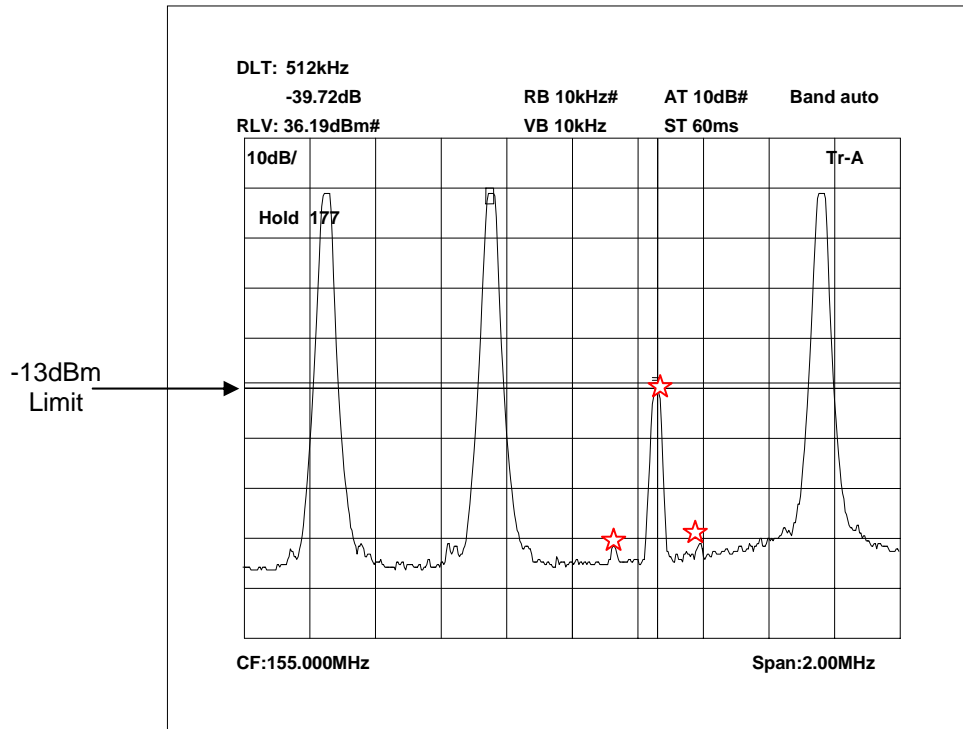

The above plot shows that all products (designated by ☆) are below the spurious limit.

Intermodulation Wideband

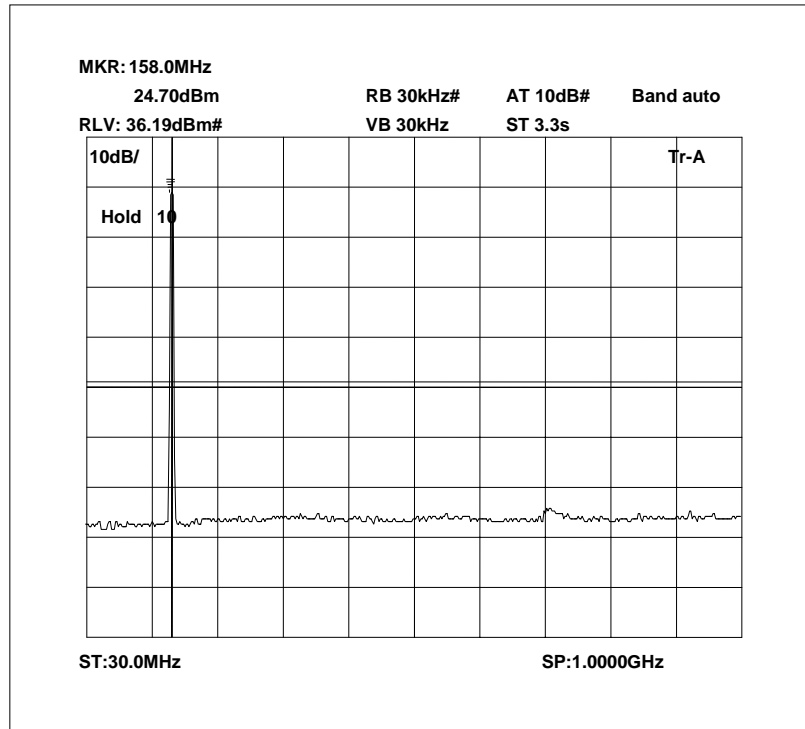

The above plot shows that there are no products outside the bands.

TRANSMITTER TESTS

AMPLIFIER MODULATED CHANNEL TEST – CONDUCTED – Part 2.1049– DOWNLINK

Ambient temperature = 28°C Radio Laboratory
 Relative humidity = 32%
 Supply voltage = 110Vac or +24Vdc
 Channel number = See test results

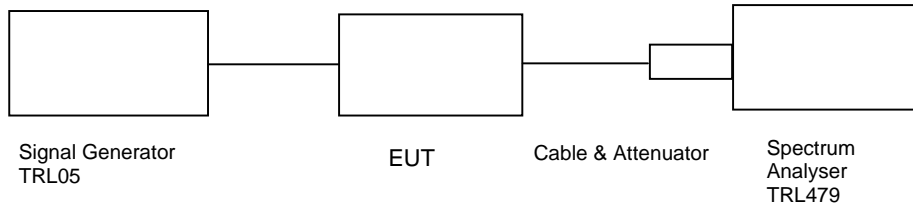

This test was performed to show that the amplifier does not alter the input signal in any way. The input signal was set to the maximum input level (4dBm) and modulated with a 2500Hz tone. The plots show the signal measured at the signal generator and the signal measured at the output of the EUT.

Note: The cables and attenuators had the following losses.

1. Cable and attenuators between EUT and analyser = 36.29dB
2. Cable between signal generator and EUT = 0.15dB

TYPE OF EQUIPMENT	MAKER/SUPPLIER	MODEL No	SERIAL No	TRL No	ACTUAL EQUIPMENT USED
SPECTRUM ANALYSER	ANRITSU	MS2665C	MT26089	479	X
ATTENUATOR	BIRD	8304-300-N	N/A	220	X
ATTENUATOR	BIRD	8304-100-N	N/A	222	X
CABLE	ROSENBERGER	MICRO COAX	N/A	280	X
CMTA	ROHDE & SCHWARZ	CMTA52	894715/033	05	X

154.0 MHz Signal Generator, deviation set to 5kHz

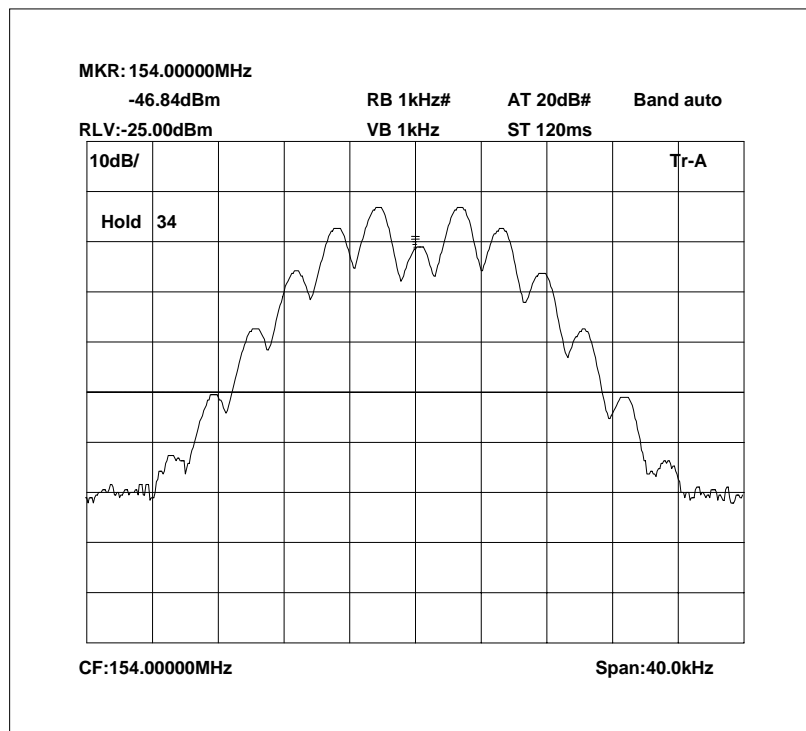

154.0 MHz Signal Generator and EUT, deviation set to 5kHz

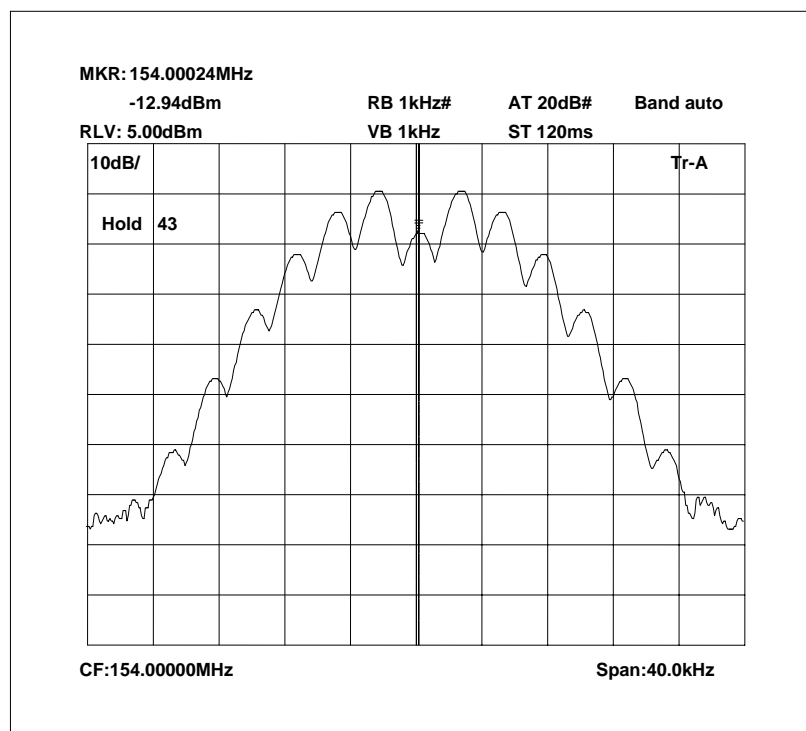

The above plots depicting the output waveshape show no measurable distortion visible when compared to the input signal.

155.0 MHz Signal Generator, deviation set to 5kHz

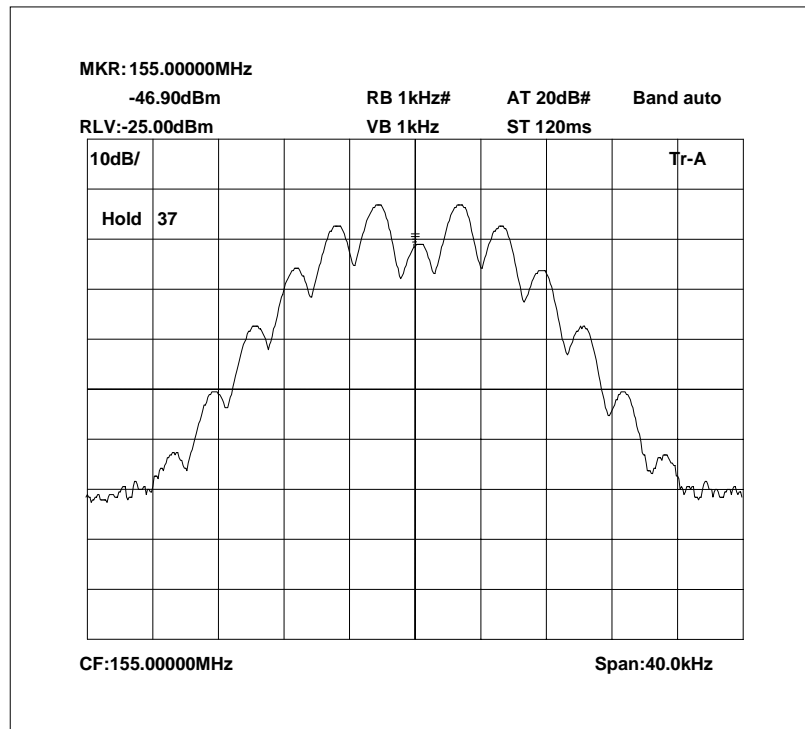

155.0 MHz Signal Generator and EUT, deviation set to 5kHz

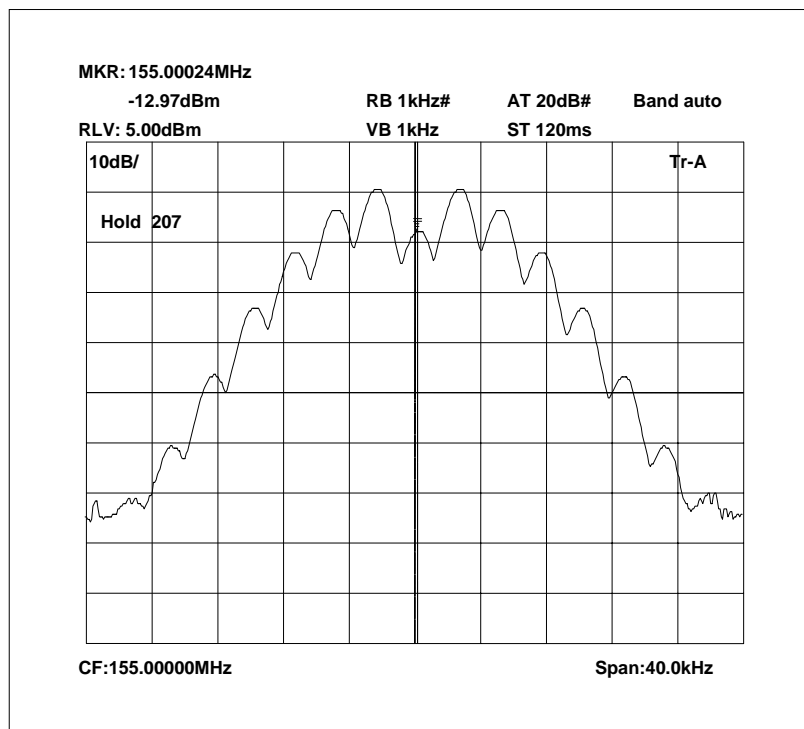

The above plots depicting the output waveshape show no measurable distortion visible when compared to the input signal.

156.0 MHz Signal Generator, deviation set to 5kHz

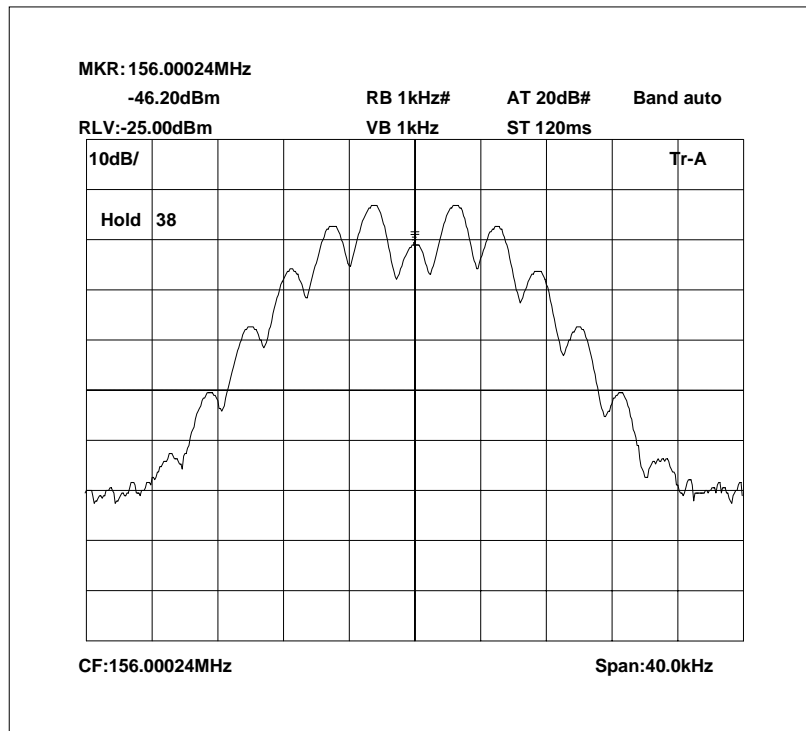

156.0 MHz Signal Generator and EUT, deviation set to 5kHz

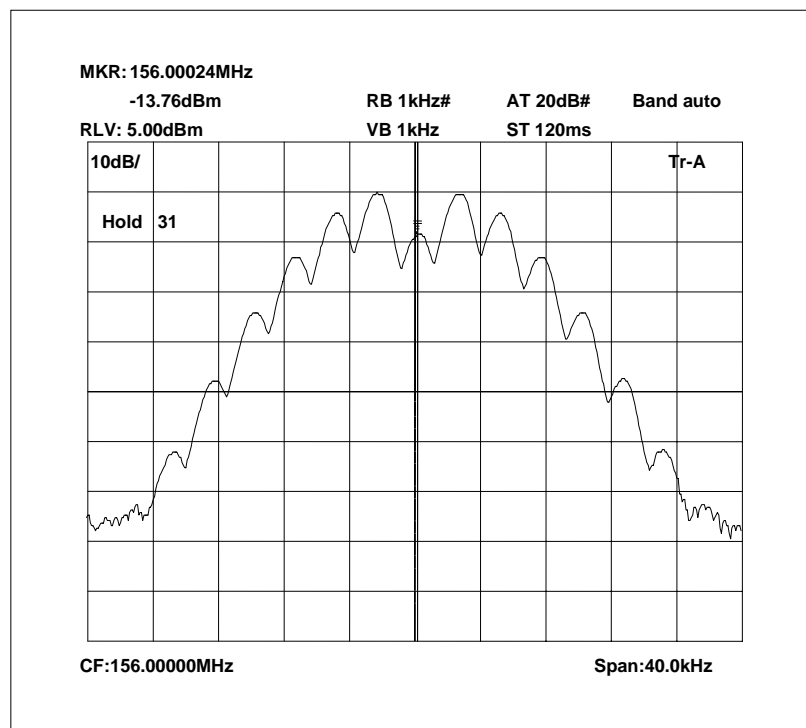

The above plots depicting the output waveshape show no measurable distortion visible when compared to the input signal.

TRANSMITTER TESTS

AMPLIFIER SPURIOUS EMISSIONS – CONDUCTED – Part 2.1053 – DOWNLINK

Ambient temperature = 23°C
 Relative humidity = 41%
 Supply voltage = 110Vac or +24Vdc

Radio Laboratory Test Signal = F3E

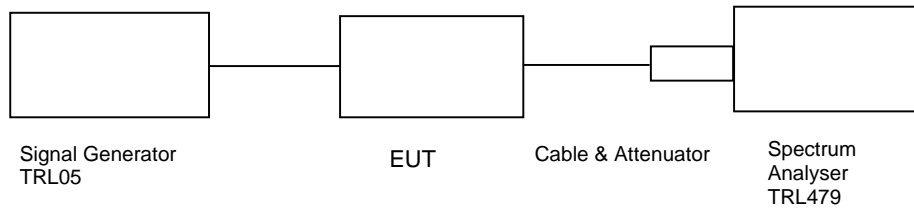

The test was set up as per the diagram. The level at the input was adjusted to compensate for the loss of the interconnecting cable. The unit was tested operating at maximum power and on three test frequencies.

The Spurious limit was calculated as follows:

On any frequency removed from the assigned frequency by more than 250% of the authorised bandwidth

At least 43 + 10 log PdB

$$(10\log P_{\text{watts}}) - (43 + 10\log (P_{\text{watts}} * 1000)) = \text{LIMIT} = -13 \text{ dBm}$$

RESULTS

FREQUENCY RANGE	FREQ. (MHz)	MEASURED LEVEL (dBm)	ATTENUATOR & CABLE LOSSES (dB)	EMISSION LEVEL (dBm)	LIMIT (dBm)
0 – 2 GHz	No Significant Emissions				-13

The test equipment used for the Transmitter Conducted Emissions:

TYPE OF EQUIPMENT	MAKER/SUPPLIER	MODEL No	SERIAL No	TRL No	ACTUAL EQUIPMENT USED
SPECTRUM ANALYSER	ANRITSU	MS2665C	MT26089	479	X
ATTENUATOR	BIRD	8304-300-N	N/A	220	X
ATTENUATOR	BIRD	8304-100-N	N/A	222	X
CABLE	ROSENBERGER	MICRO COAX	N/A	280	X
CMTA	ROHDE & SCHWARZ	CMTA52	894715/033	05	X

Conducted emissions 154.0 MHz 0 – 1GHz

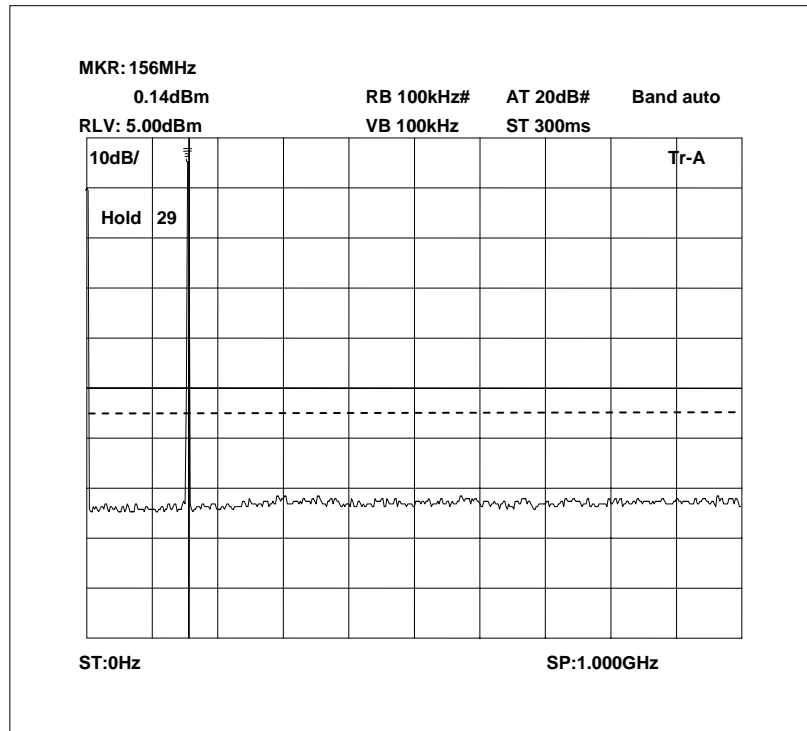

Conducted emissions 154.0 MHz 1 – 2GHz

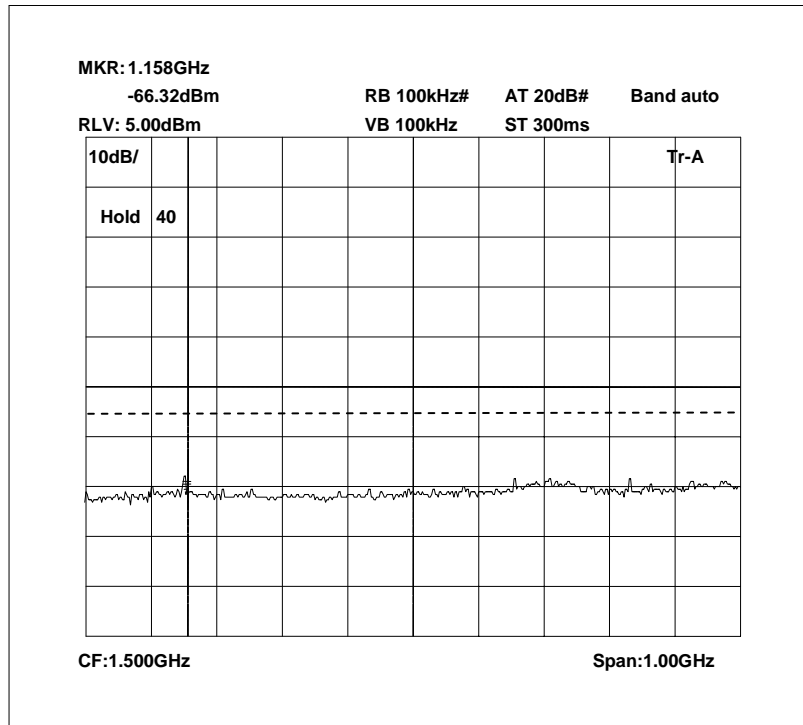

Conducted emissions 155.0 MHz 0 – 1GHz

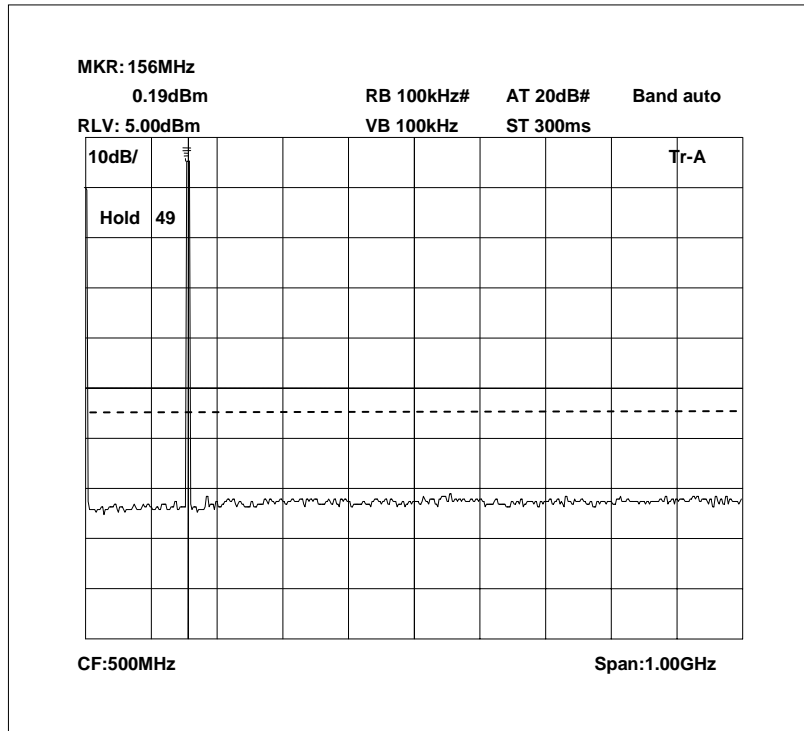

Conducted emissions 155.0 MHz 1 – 2GHz

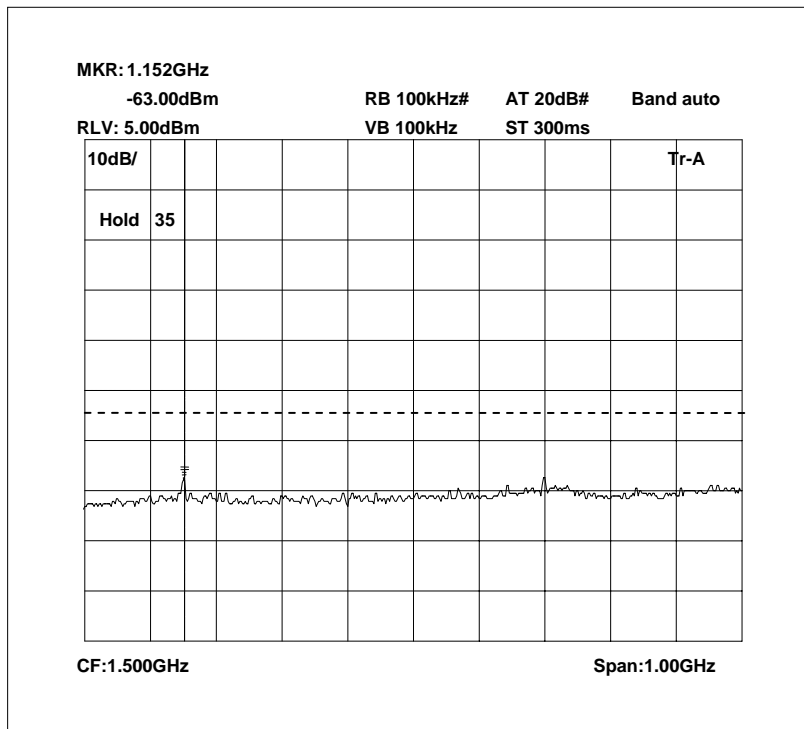

Conducted emissions 156.0 MHz 0 – 1GHz

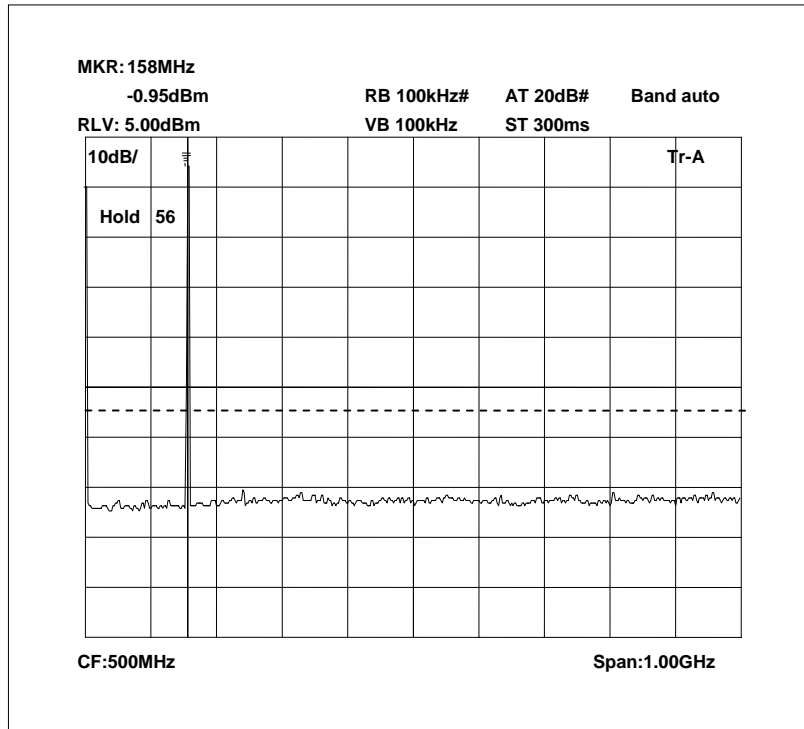

Conducted emissions 156.0 MHz 1 – 2GHz

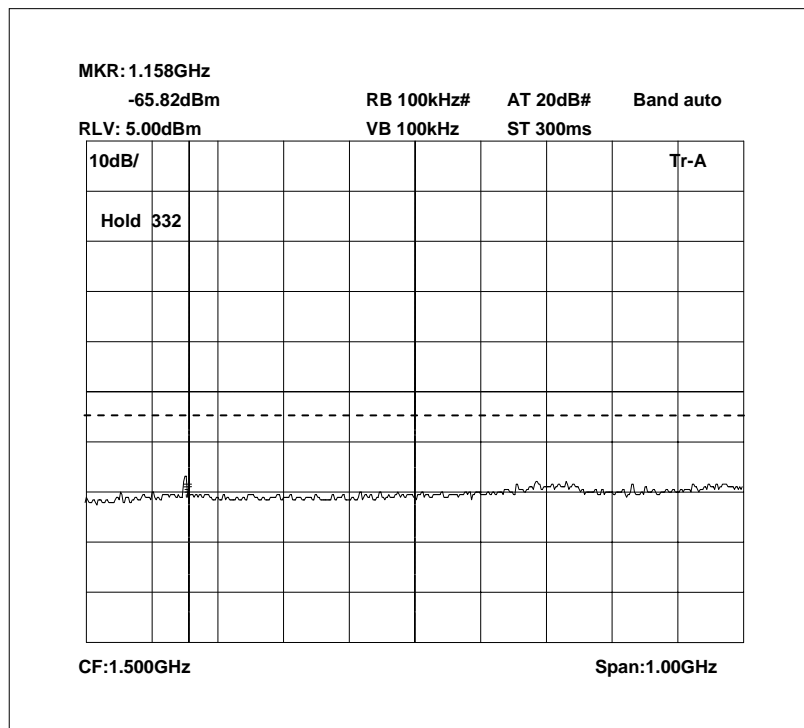

TRANSMITTER TESTS

AMPLIFIER SPURIOUS EMISSIONS – RADIATED – Part 2.1053– DOWNLINK

Ambient temperature = 24°C
 Relative humidity = 45%
 Conditions = OATS
 Supply voltage = 110Vac or +24Vdc
 Supply Frequency = N/A

Test Signal = F3E

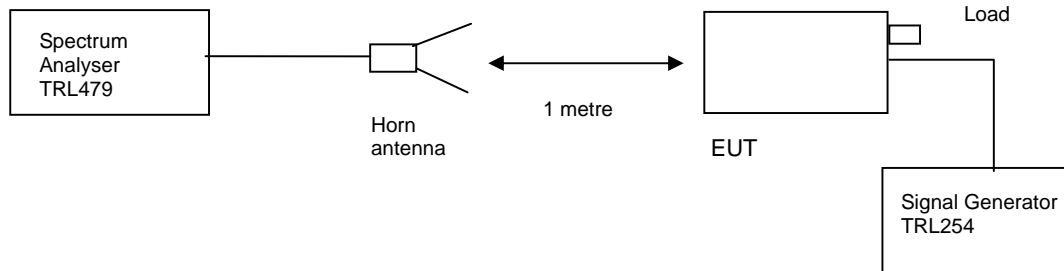

The test was set up as per the diagram. The level at the input was adjusted to compensate for the loss of the interconnecting cable. The unit was tested operating maximum power on three test frequencies with a 50 ohm load on the output. The unit was also tested with the signal generator replaced by another 50ohm load.

The Spurious limit was calculated as follows:

On any frequency removed from the assigned frequency by more that 250% of the authorised bandwidth

At least 43 + 10 log PdB

$$(10\log P_{\text{watts}}) - (43+10\log (P_{\text{watts}} * 1000)) = \text{LIMIT} = -13 \text{ dBm}$$

RESULTS

FREQUENCY RANGE	FREQ. (MHz)	MEAS. Rx. (dBµV)	CABLE LOSS (dB)	ANT FACTOR	FIELD STRENGTH (dBµV/m)	CALCULATED EIRP (dBm)	LIMIT (dBm)
0 – 2GHz	No Significant Emissions within						

The test equipment used for the Transmitter Spurious Emissions:

TYPE OF EQUIPMENT	MAKER/SUPPLIER	MODEL No	SERIAL No	TRL No	ACTUAL EQUIPMENT USED
SPECTRUM ANALYSER	ANRITSU	MS2665C	MT26089	479	X
HORN	EMCO	3115	9010-3581	139	X
ATTENUATOR	BIRD	8304-300-N	N/A	220	X
CABLE	ROSENBERGER	MICRO COAX	N/A	280	X
SIGNAL GENERATOR	MARCONI	2042	119562/021	254	X

Radiated emissions 154.0 MHz 0 – 1GHz

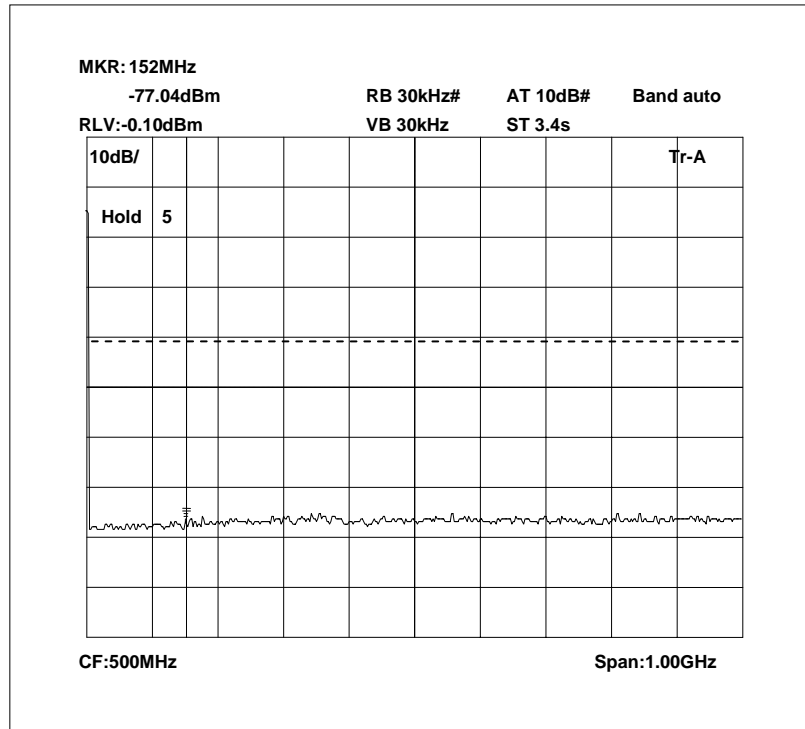

Radiated emissions 154.0 MHz 1 – 2GHz

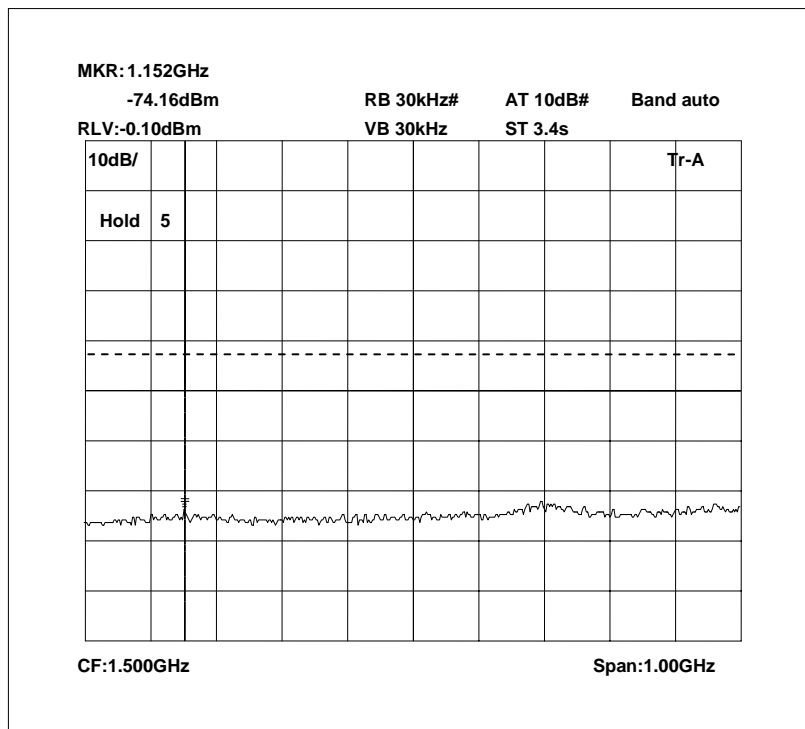

The above test results show that there were no emissions within 20dBs of the -13dBm limit.

Radiated emissions 155.0 MHz 0 – 1GHz

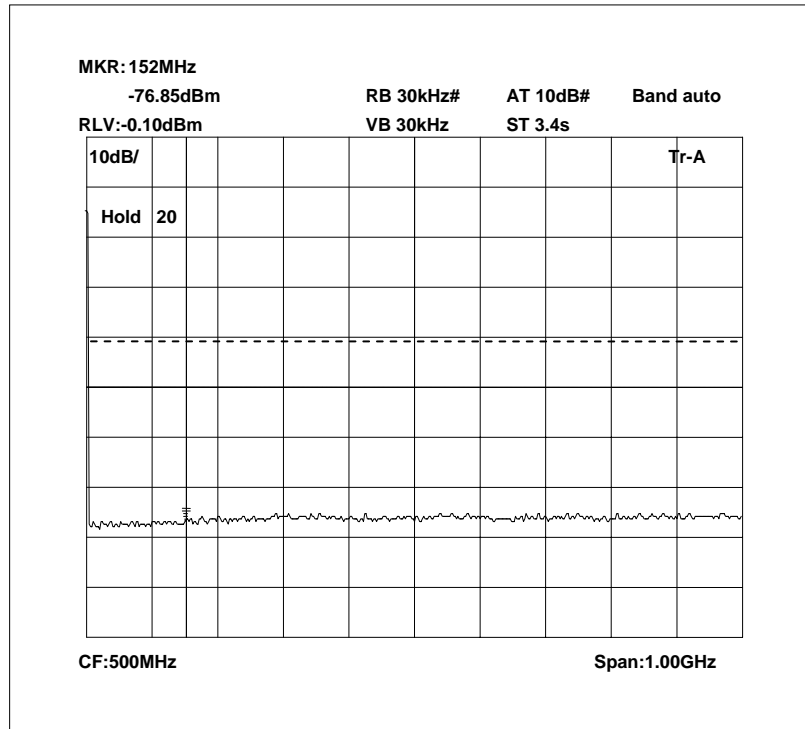

Radiated emissions 155.0 MHz 1 – 2GHz

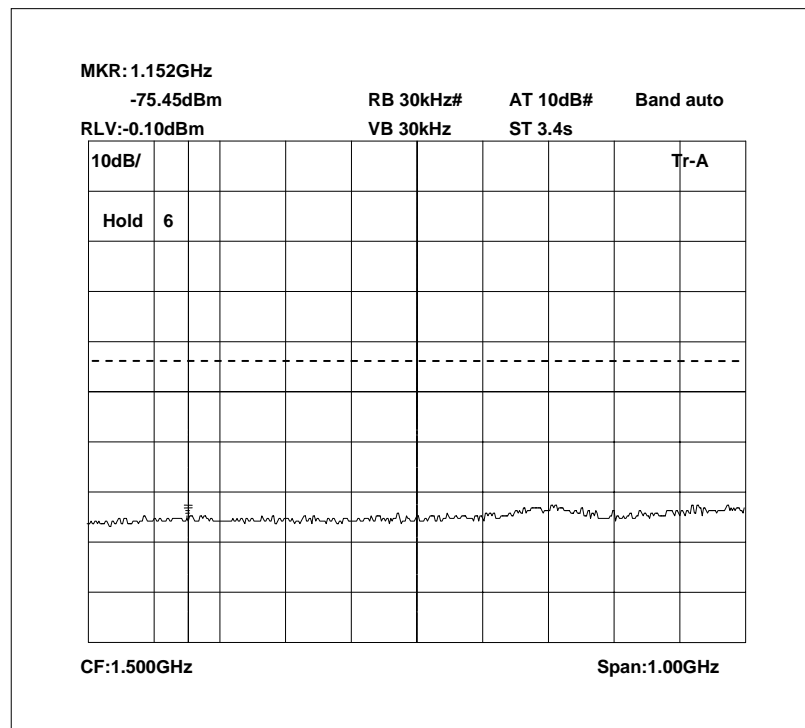

The above test results show that there were no emissions within 20dBs of the -13dBm limit.

Radiated emissions 156.0 MHz 0 – 1GHz

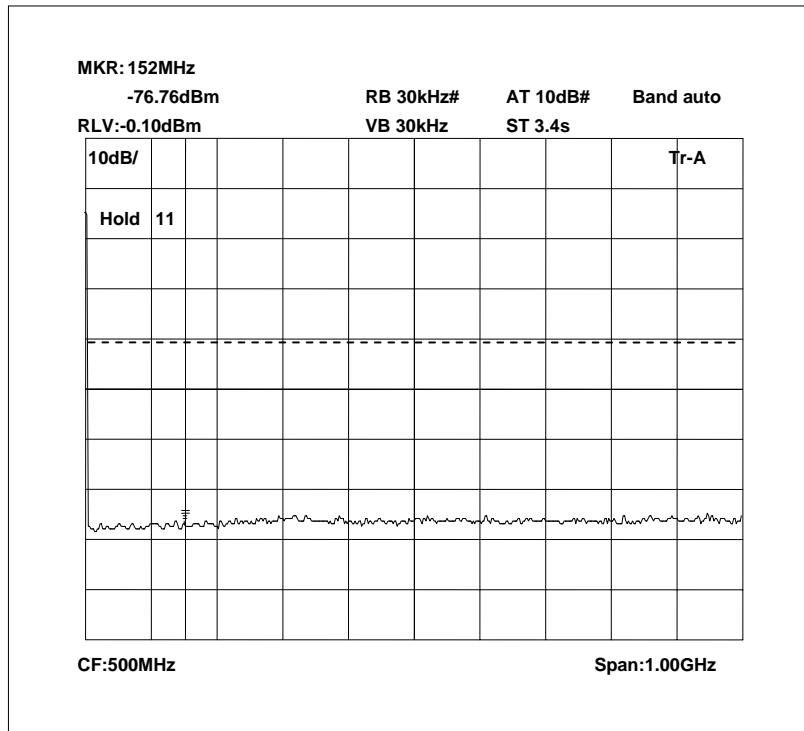

Radiated emissions 156.0 MHz 1 – 2GHz

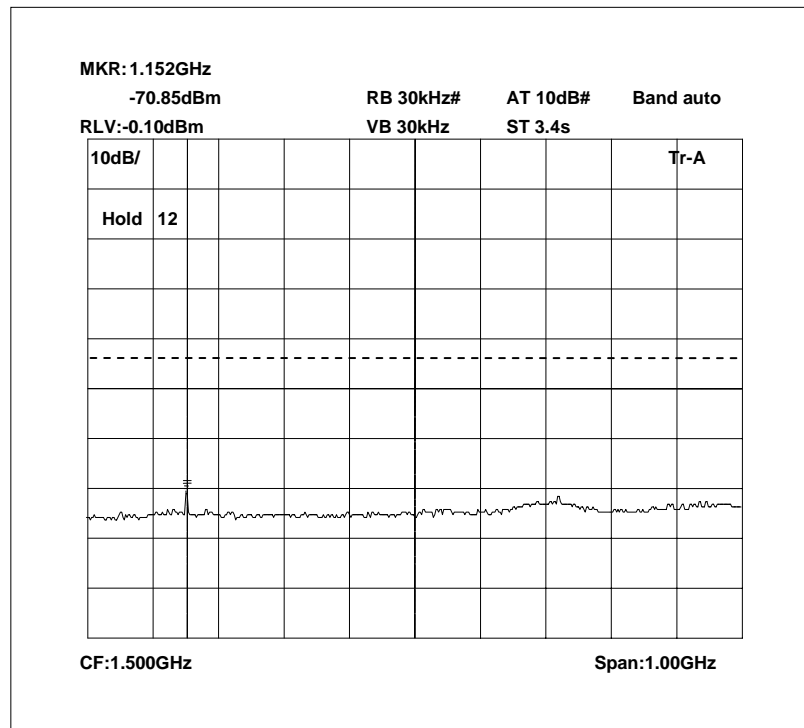

The above test results show that there were no emissions within 20dBs of the -13dBm limit.

Radiated emissions no input signal 0 – 1GHz

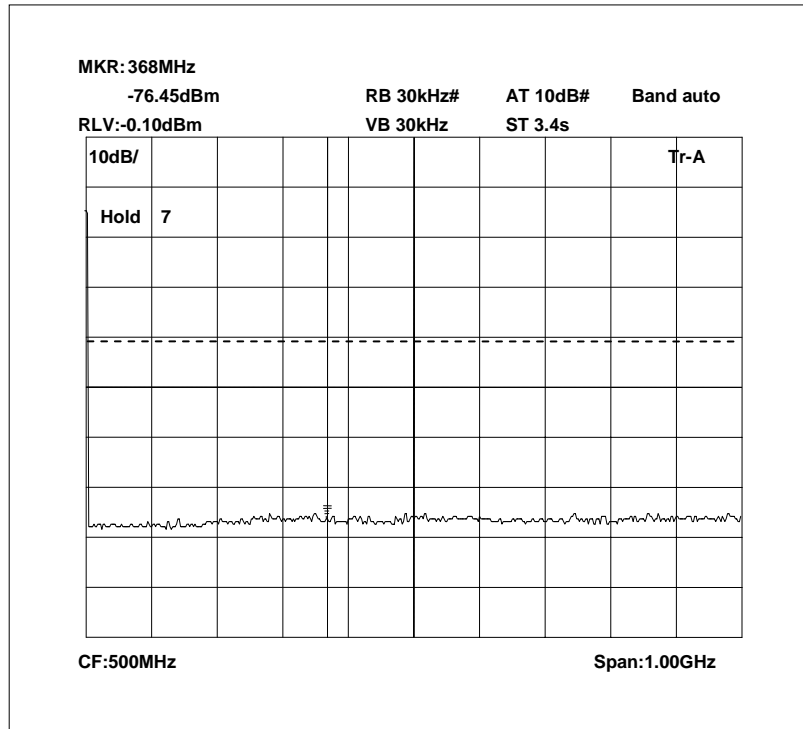

Radiated emissions no input signal 1 – 2GHz

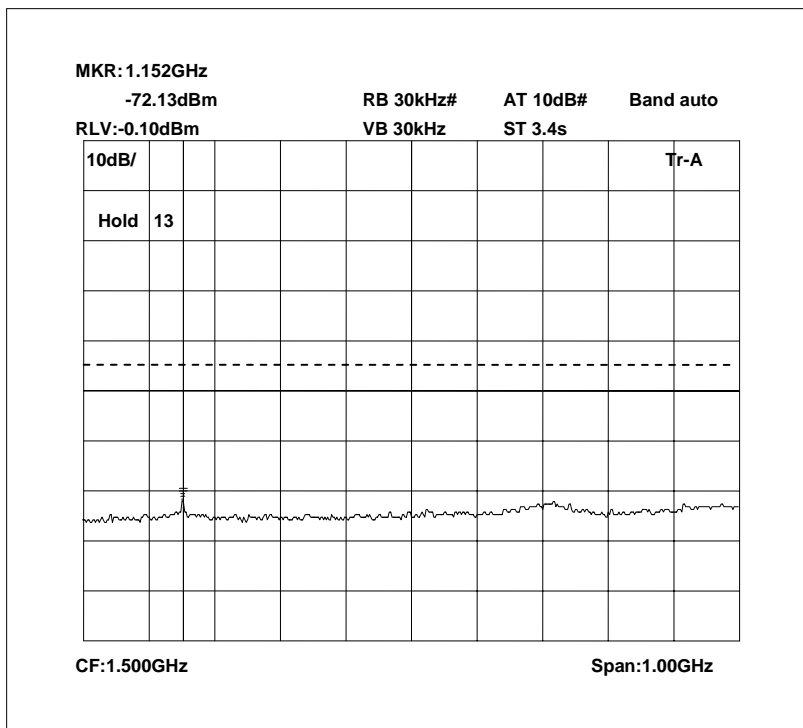

The above test results show that there were no emissions within 20dBs of the -13dBm limit.

ANNEX A
PHOTOGRAPHS

PHOTOGRAPH No. 1

TEST SETUP



PHOTOGRAPH No. 2

TEST SETUP



ANNEX B
APPLICANT'S SUBMISSION OF DOCUMENTATION LIST

APPLICANT'S SUBMISSION OF DOCUMENTATION LIST

a.	TCB	-	APPLICATION	[X]
		-	FEE	[X]
b.	AGENT'S LETTER OF AUTHORISATION	-		[X]
c.	MODEL(s) vs IDENTITY	-		[]
d.	ALTERNATIVE TRADE NAME DECLARATION(s)	-		[]
e.	LABELLING	-	PHOTOGRAPHS	[]
		-	DECLARATION	[]
		-	DRAWINGS	[]
f.	TECHNICAL DESCRIPTION	-		[X]
g.	BLOCK DIAGRAMS	-	Tx	[X]
		-	Rx	[]
		-	PSU	[]
		-	AUX	[]
h.	CIRCUIT DIAGRAMS	-	Tx	[]
		-	Rx	[]
		-	PSU	[]
		-	AUX	[]
i.	COMPONENT LOCATION	-	Tx	[]
		-	Rx	[]
		-	PSU	[]
		-	AUX	[]
j.	PCB TRACK LAYOUT	-	Tx	[]
		-	Rx	[]
		-	PSU	[]
		-	AUX	[]
k.	BILL OF MATERIALS	-	Tx	[]
		-	Rx	[]
		-	PSU	[]
		-	AUX	[]
l.	USER INSTALLATION / OPERATING INSTRUCTIONS	-		[X]

ANNEX C
TEST EQUIPMENT CALIBRATION

TRL Number	Equipment Type	Manufacturer	Last Cal Calibration	Calibration Period	Due For Calibration
UH006	3m Range ERP CAL	TRL	01/03/05	12	01/03/06
UH028	Log Periodic Ant	Schwarbeck	28/04/05	24	28/04/07
UH029	Bicone Antenna	Schwarbeck	27/04/05	24	27/04/07
UH041	Multimeter	AVOmeter	14/12/04	12	14/12/05
UH120	Spectrum Analyser	Marconi	15/03/05	12	15/03/06
UH122	Oscilloscope	Tektronix	07/06/05	24	07/06/07
UH162	ERP Cable Cal	TRL	23/05/05	12	23/05/06
UH179	Power Sensor	Marconi	14/12/04	12	14/12/05
UH228	Power Sensor	Marconi	17/01/05	12	17/01/06
UH253	1m Cable N type	TRL	10/01/05	12	10/01/06
UH254	1m Cable N type	TRL	10/01/05	12	10/01/06
UH265	Notch filer	Telonic	24/06/05	12	24/06/06
L005	CMTA	R&S	22/10/04	12	22/10/05
L007	Loop Antenna	R&S	29/03/05	24	29/03/07
L138	1-18GHz Horn	EMCO	15/04/05	24	15/04/07
L139	1-18GHz Horn	EMCO	03/05/05	24	03/05/07
L176	Signal Generator	Marconi	31/01/05	12	31/01/06
L193	Bicone Antenna	Chase	12/10/03	24	12/10/05
L203	Log Periodic Ant	Chase	21/10/03	24	21/10/05
L254	Signal Generator	Marconi	13/12/04	12	13/12/05
L280	18GHz Cable	Rosenberger	10/01/05	12	10/01/06
L343	CCIR Noise Filter	TRL	07/06/05	12	07/06/06
L426	Temperature Indicator	Fluke	14/12/04	12	14/12/05
L478	Signal Generator	R&S	19/05/04	12	19/05/05
L479	Analyser	Anritsu	05/10/04	12	05/10/05
L552	Signal Generator	Agilent	25/04/05	12	25/04/06
L031	Power Amp	ENI	Cal in use	N/A	N/A

ANNEX D
MEASUREMENT UNCERTAINTY

Radio Testing – General Uncertainty Schedule

All statements of uncertainty are expanded standard uncertainty using a coverage factor of 1.96 to give a 95% confidence where no required test level exists.

[1] Adjacent Channel Power

Uncertainty in test result = **1.86dB**

[2] Carrier Power

Uncertainty in test result (Equipment - TRLUH120) = **2.18dB**

Uncertainty in test result (Equipment – TRL05) = **1.08dB**

Uncertainty in test result (Equipment – TRL479) = **2.48dB**

[3] Effective Radiated Power

Uncertainty in test result = **4.71dB**

[4] Spurious Emissions

Uncertainty in test result = **4.75dB**

[5] Maximum frequency error

Uncertainty in test result (Equipment - TRLUH120) = **119ppm**

Uncertainty in test result (Equipment – TRL05) = **0.113ppm**

Uncertainty in test result (Equipment – TRL479) = **0.265ppm**

[6] Radiated Emissions, field strength OATS 14kHz-18GHz Electric Field

Uncertainty in test result (14kHz – 30MHz) = **4.8dB**, Uncertainty in test result (30MHz – 1GHz) = **4.6dB**, Uncertainty in test result (1GHz-18GHz) = **4.7dB**

[7] Frequency deviation

Uncertainty in test result = **3.2%**

[8] Magnetic Field Emissions

Uncertainty in test result = **2.3dB**

[9] Conducted Spurious

Uncertainty in test result (Equipment TRL479) Up to 8.1GHz = **3.31dB**

Uncertainty in test result (Equipment TRL479) 8.1GHz – 15.3GHz = **4.43dB**

Uncertainty in test result (Equipment TRL479) 15.3GHz – 21GHz = **5.34dB**

Uncertainty in test result (Equipment TRLUH120) Up to 26GHz = **3.14dB**

[10] Channel Bandwidth

Uncertainty in test result = **15.5%**

[11] Amplitude and Time Measurement – Oscilloscope

Uncertainty in overall test level = **2.1dB**, Uncertainty in time measurement = **0.59%**, Uncertainty in Amplitude measurement = **0.82%**

[11] Power Line Conduction

Uncertainty in test result = **3.4dB**

ANNEX E
SYSTEM DIAGRAM

