



Electromagnetic Compatibility Test Report

Test Report No: COB 260619 Rev. 2
Issued on: June 26, 2019

Product Name
RRU High Power

Tested According to
FCC 47 CFR, Part 22
869 MHz – 894 MHz Band

Tests Performed for
Axell Wireless
Qiryat Matalon, Petah Tikva, 49002,
Tel: +972-3-918 0180

QualiTech EMC Laboratory

30 Hasivim Street, P.O.Box 7500
Petah-Tikva, 4951169, Israel
Tel: +972-3-926-6994
Fax: +972-3-928 7490



The information contained herein is the property of QualiTech, EMC Lab and is supplied without liability for errors or omissions.

*The copyright for this document vests in QualiTech, EMC Lab.
All rights reserved.*

This Test Report may not be reproduced, by any method, without the written permission of the QualiTech, EMC Lab.

If and when such permission is granted, the report must be reproduced only in the full format.

Test Personnel



Tests Performed By: -----

Dmitri Babiev



Report Prepared By: -----

Bina Talkar



Report Reviewed By: -----

Rami Nataf
EMC Lab. Manager
QualiTech EMC Laboratory

Test Report details:

Test commencement date: 03.04.2019
Test completion date: 06.06.2019
Customer's representative: David Cohen
Issued on: 29.10.2019

Revision details:

Version	Date	Details/Reasons
Rev. 1	26.06.2019	-
Rev. 2	29.10.2019	Updated according to TCB comments

Assessment information:

This report contains an assessment of the EUT against Radio testing based upon tests carried out on the samples submitted. The results contained in this report relate only to the items tested. Manufactured products will not necessarily give identical results due to production and measurement tolerances. QualiTech, Radio Lab does not assume responsibility for any conclusion and generalization drawn from the test results with regards to other specimens or samples of type of the equipment represented by test item.

The EUT was set up and exercised using the configuration, modes of operation and arrangements defined in this report only.

Modifications:

Modifications made to the EUT

None.

Modifications made to the Test Standard

None.

Summary of Compliance Status

Test Spec. Clause	Test Case	Remarks
Specific Requirements		
-KDB 935210 D05 v01r02, sec. 3.3	Out-of-Band Rejection	Pass
General Requirements		
-47 CFR §2.1049(h) -KDB 935210 D05 v01r02, sec.3.4	Occupied Bandwidth - Input-versus-output signal comparison	Pass
-47 CFR §22.913 -47 CFR §2.1046 -KDB 935210 D05 v01r02, sec. 3.5.4	Mean Output Power and Amplifier/Booster Gain	Pass
-47 CFR §22.917(a) -47 CFR §2.1051 -KDB 935210 D05 v01r02, sec. 3.6.2, Conducted	Out-of-Band/Out-of-Block & Intermodulation Emissions Conducted Measurements	Pass
-47 CFR §22.917 -47 CFR §2.1051 -KDB 935210 D05 v01r02, sec. 3.6.2, Conducted	Spurious Emission - Conducted Measurement	Pass
-47 CFR §22.917 -47 CFR §2.1053 -KDB 935210 D05 v01r02, sec. 3.8, Radiated	Spurious Emissions – Radiated Measurement	Pass
-47 CFR §22.355 -47 CFR §2.1055 -KDB 935210 D05 v01r02, sec. 3.7, Conducted	Frequency Stability	Pass



Table of Contents

1. GENERAL.....	6
1.1. Referenced documents.....	6
1.2. Product Description.....	7
2. TEST FACILITY & UNCERTAINTY OF MEASUREMENT.....	9
2.1. Accreditation / Registration reference.....	9
2.2. Test Facility description.....	9
3. EXAMINATION TEST RESULTS.....	11
3.1. Out-of-Band Rejection.....	11
3.2. Occupied Bandwidth - Input-versus-output signal comparison.....	12
3.3. Mean Output Power and Amplifier/Booster Gain.....	15
3.4. Out-of-Band/Out-of-Block & Intermodulation Emissions Conducted Measurements.....	16
3.5. Spurious Emission Conducted Measurement.....	21
3.6. Spurious Emissions, Radiated Measurements.....	28
3.7. Frequency stability.....	35
4. APPENDIX.....	36

1. General

1.1. Referenced documents

- KDB 935210 D05 v01r02 :** Measurements Guidance for Industrial and Non-consumer Signal Booster, Repeater and Amplifiers Devices.
- ANSI/TIA-603-D :** Land Mobile FM or PM Communications Equipment and Performance Standards.

1.2. Product Description

FCC ID: NEO43ID7D8C17C19A

IC: 8749A-43ID7817C19

Model Numbers: id-DAS-RRU-M-4307-4308-4317-4319-AC-F

Serial Number: 18061383

Description of the EUT system/test Item:

idRU – The idRU is an IP 65 outdoor as well as indoor four-band remote unit, where two units can be cascaded through a CPRI link to support eight bands. Each band can provide maximum power of 43 dBm ± 0.75dB per band. The Remote Units serve as the backhaul port of any IP device or switch in the neighborhood; thus, it distributes combined cellular and data services according to user defined configuration profiles. The idRU is connected to the MSDH via 10 Gbit/s CPRI interfaces, where each interface contains an Embedded 1Gbit/s IP backhaul link.

Description of the EUT system/test Item:

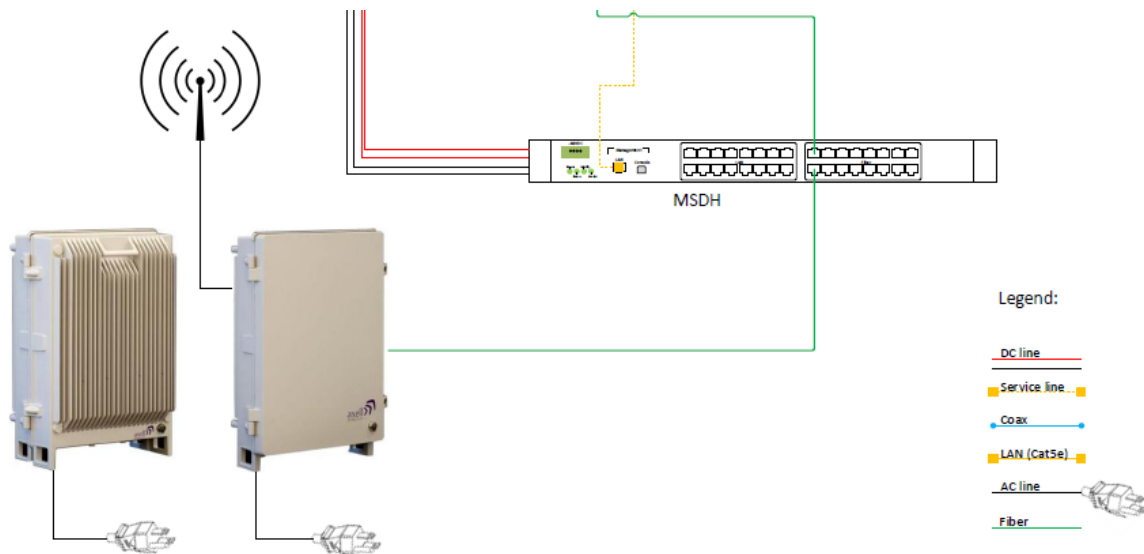

Bands and Modulations: Fc = 893.717 MHz

Technology	Direction	Modulation & Bandwidth	Frequency Band	Maximum Output Power
AC Model				
GSM	Downlink	QPSK,0.2 MHz	869 - 894 MHz	38.03dBm, 6.353w
CDMA	Downlink	1.25MHz		42.79dBm, 19.011w
WCDMA	Downlink	5MHz		42.79dBm, 19.011w
LTE	Downlink	64 QAM 1.4MHz		42.79dBm, 19.011w
		64 QAM 5MHz		42.79dBm, 19.011w
		64 QAM 20 MHz		42.79dBm, 19.011w

Support /Ancillary Equipment:

For the purposes of this test report, ancillary equipment is defined as equipment which is used in conjunction with the EUT to provide operational features to the EUT.

The system was configured in a typical fashion, as it would be normally used. However, the ancillary equipment can influence the test results.

Test Setup and Module Description:

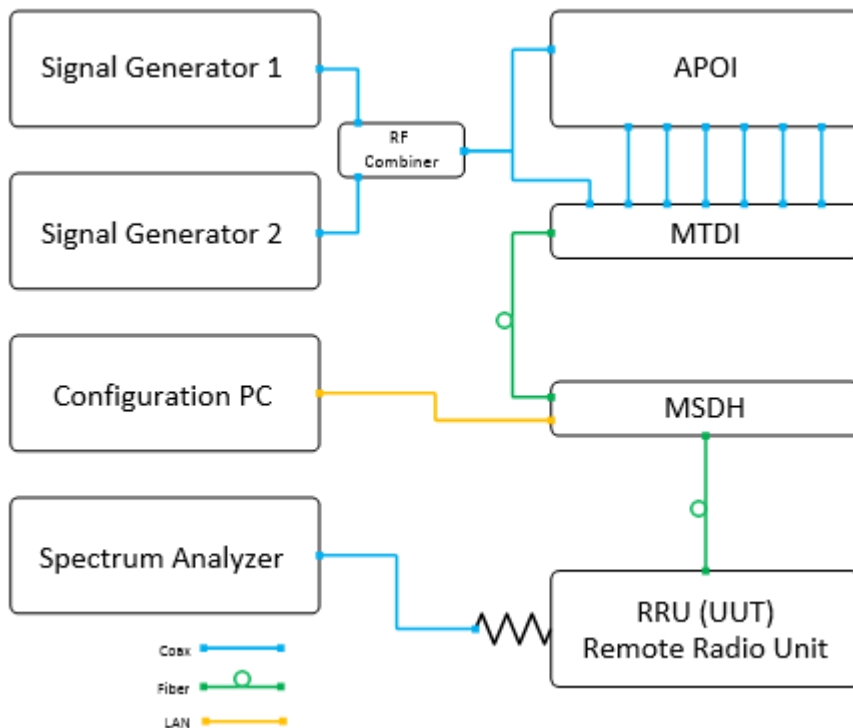

Signal Generator 1 and Signal Generator 2 generates a single tone or two-tones to the system. The tones can be selected to be CW or modulated. The signal can be routed either to the APOI or MTDI via Coax.

The APOI (Active Point of Interface), conditions and controls level of up to 16 low power BTS sectors of up to 30dBm. (Separate low PIM attenuators are used for higher power signals.)

The signals are conditioned by up to eight, band-specific modules, supporting two same-band sectors. The conditioned signals of each module are converged and fed to the corresponding (band-specific) MTDI module for digitization.

The MTDI (Multi Technology Digital Interface) unit digitizes and filters up to 16 conditioned cellular RF sectors from one more A-POI shelves. It then combines the signals over a single CPRI link that is routed towards the MSDH.

The MSDH (Multi Sector Digital Hub) serves as the idDAS central switching hub and control system. It routes digitized cellular resources received from MTDI units, along with data from the Ethernet network, over CPRI links towards the relevant remotes.

2. Test Facility & Uncertainty of Measurement

2.1. Accreditation / Registration reference

- A2LA Certificate Number: 1633.01
- IC Canada: Site# 4808A-1

2.2. Test Facility description

The tests were performed at the EMC Laboratory, QualiTech Division, ECI Telecom Group

Address: 30, Hasivim St., Petah Tikva, Israel.
Tel: 972-3-926-6994

3m Anechoic Chamber:

Measurement distance	3m
Chamber dimensions	9.5m x 6.5m x 5.2m
Antenna height	1 - 4m
Shielding Effectiveness	Magnetic field ≥ 80 dB at 15 kHz ≥ 90 dB at 100 kHz Electric field > 120 dB from 1MHz to 1GHz > 110 dB from 1GHz to 10GHz
Absorbing material	Ferrite tiles on the walls and ceiling Emerson and Cuming absorbing material in selected positions on the walls
Normalized Site Attenuation measured at 5 positions	± 3.9 dB, 30MHz to 200MHz ± 3 dB, 200MHz to 1000MHz
Transmission Loss measured at 5 positions, at 1.5m height	± 3 dB, 1GHz to 18GHz

Uncertainty of Measurement:

The data and results referenced in this document are true and accurate. The reader is cautioned that there may be errors within the calibration limits of the equipment and facilities. The measurement uncertainty was calculated for all measurements listed in this test report according to CISPR 16-4-2 “Specification for radio disturbance and immunity measuring apparatus and methods – Part 4-2: Uncertainties, statistics and limit modelling – Uncertainty in EMC measurements “. Furthermore, component and process variability of devices similar to that tested may result in additional deviation. The manufacturer has the sole responsibility of continued compliance of the device.

Test Name	Test Method & Range	Uncertainty	
		Combined std. Uc(y)	Expanded U
Radiated Emission	30MHz÷230MHz, Horiz. polar.	[dB] 1.8	[dB] 3.6
	30MHz÷230MHz, Ver. polar.	1.967	3.934
	230MHz÷1000MHz, Horiz. polar.	1.487	2.973
	230MHz÷1000MHz, Vert. polar.	1.499	2.998
Conducted Emission	9 kHz÷150 kHz	[dB] 1.378	[dB] 2.756
	150 kHz÷30MHz	1.095	2.190
Radio frequency	Up to 18 GHz	$\pm 1 \cdot 10^{-6}$	$< \pm 1 \cdot 10^{-5}$
Total Conducted RF Power	Up to 18 GHz	± 1.378 dB	$< \pm 1.5$ dB
Conducted Power density	Up to 18 GHz	± 1.378 dB	$< \pm 3$ dB
Temperature	23.6 °C	± 0.6 °C	$< \pm 2$ °C
Humidity	54.9%	± 3.1 %	$< \pm 5$ %
DC Voltage	0-60 VDC	± 0.3 %	$< \pm 3$ %

Note: QualiTech EMC labs expanded measurement instrumentation has less uncertainty than the industry norm and compliance is deemed to occur as no measured disturbance exceeds the disturbance limit.

Note: The reported expanded uncertainty is based on a standard uncertainty multiplied by a coverage factor of k=2, providing a level of confidence of approximately 95%.

3. Examination Test Results

3.1. Out-of-Band Rejection

Reference document:	KDB 935210 D05 v01r02		
Method of testing:	KDB 935210 D05 v01r02, Conducted	Pass	
Operating conditions:	Under normal test conditions		
Environment conditions:	Ambient Temperature: 22.9°C	Relative Humidity: 59.6%	Atmospheric Pressure: 1011.4 hPa
Test Result:	See below	See Plot 3.1	

Test results:

Modulation	±250% of Passband*, MHz	Frequency fo, MHz	-20dB lowest point, MHz	-20dB highest point, MHz
CW	806.5...956.5	893.717	868.654	894.589

* 25MHz passband

Plot 3.1: Out-of-Band rejection, CW

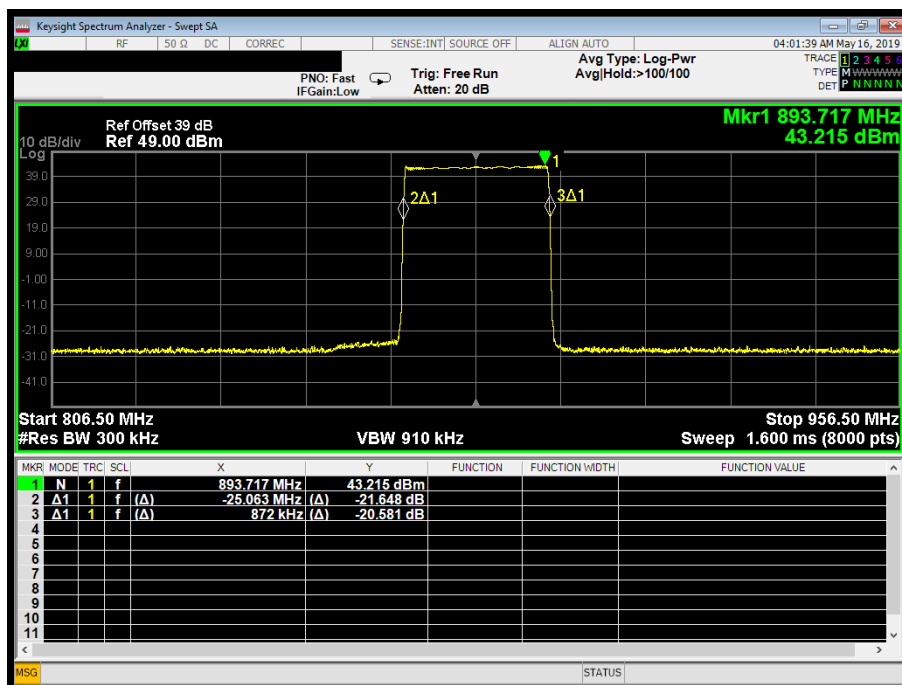

3.2. Occupied Bandwidth - Input-versus-output signal comparison

Reference document:	47 CFR §2.1049(h)		
Test Requirements:	<p>The occupied bandwidth, that is the frequency bandwidth such that, below its lower and above its upper frequency limits, the mean powers radiated are each equal to 0.5 percent of the total mean power radiated by a given emission shall be measured under the following conditions as applicable.</p> <p>A 26 dB bandwidth measurement shall be performed on the input signal and the output signal; alternatively, the 99% OBW can be measured and used.</p> <p>The spectral plot of the input signal shall be similar to the output signal.</p>		
Method of testing:	KDB 935210 D05 v01r02, Conducted	Pass	
Operating conditions:	Under normal test conditions		
Environment conditions:	Ambient Temperature: 22.3°C	Relative Humidity: 57.8%	Atmospheric Pressure: 1011.4 hPa
Test Result:	See below	See Plots 3.2.1 - 3.2.4	

Test results:

Mode	Operating Frequency, MHz	-26 dB Bandwidth, MHz	
		Output	Input
		0.5 dB below AGC threshold level	0.5 dB below AGC threshold level
MSK, Gaussian filter 0.3 data rate 270kbps	881.500	311.000 kHz	323.000 kHz
AWGN 4.1MHz	881.500	4.665 MHz	4.675 MHz
		3 dB above AGC threshold level	3 dB above AGC threshold level
MSK, Gaussian filter 0.3 data rate 270kbps	881.500	311.000 kHz	323.000 kHz
AWGN 4.1MHz	881.500	4.662 MHz	4.669 MHz

Note: Only at MSK modulation (GSM) the Composite Output Power transmission is 38 dBm.

Plot 3.2.1: Input-versus-output signal comparison, MSK, Gaussian filter 0.3, data rate 270kbps, 0.5 dB below AGC threshold level

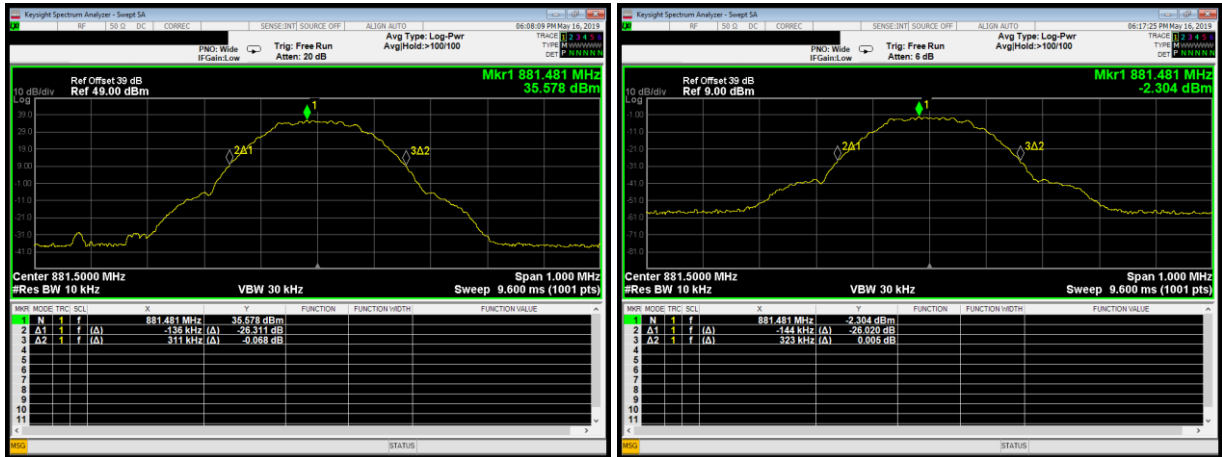

Output

Input

Plot 3.2.2: Input-versus-output signal comparison, MSK, Gaussian filter 0.3, data rate 270kbps, 3 dB above AGC threshold level



Output

Input

Plot 3.2.3: Input-versus-output signal comparison, AWGN 4.1MHz, 0.5 dB below AGC threshold level



Output

Input

Plot 3.2.4: Input-versus-output signal comparison, AWGN 4.1MHz, 3 dB above AGC threshold level



Output

Input

3.3. Mean Output Power and Amplifier/Booster Gain

Reference document:	47 CFR §22.913, 47 CFR §2.1046		
Test Requirements:	The effective radiated power (ERP) of base transmitters and cellular repeaters must not exceed 500 Watts		
Method of testing:	For 47CFR: KDB 935210 D05 v01r02, sec 3.5(power meter method);	Pass	
Operating conditions:	Under normal test conditions		
Environment conditions:	Ambient Temperature: 22.4°C	Relative Humidity: 59.8%	Atmospheric Pressure: 1011.4 hPa
Test Result:	See below	-	

Test results:

Mode	Operating Frequency (fo) ¹ MHz	Measured AVG Power				Mean Gain ² [dB]	Max Ant Gain [dBd]	ERP Calculated ³ [W]	Power Limit [W/MHz]	Delta ⁴ [W/MHz]	Pass/Fail
		Output		Input							
AWGN 4.1 MHz	893.717	42.79 dBm	19.011 W	-0.08 dBm	981.75 μW	42.79	11.85	291.072	1000	-708.928	Pass
MSK, Gaussian filter 0.3 data rate 270kbps	893.717	38.03 dBm	6.353 W	0.14 dBm	1.033 mW	38.03	11.85	97.286	1000	-902.714	Pass

Note: The EUT tested at 0.5 dB below AGC threshold level and 3 dB above AGC threshold level, and worst case results were presented.

Note: Only at MSK modulation (GSM) the Composite Output Power transmission is 38 dBm.

¹ From "Out-of-Band Rejection" test

² Mean Gain [dB] = Measured AVG Power (Output) [W] - Measured AVG Power (Input) [W]

³ ERP Calculated [W] = $10^{[(\text{Measured AVG Power (Output) [dBm]} + \text{Max Ant Gain [dBd]}) / 10]} / 1000$

⁴ Delta [W/MHz] = ERP Calculated [W] - Power Limit [W/MHz]

3.4. Out-of-Band/Out-of-Block & Intermodulation Emissions Conducted Measurements

Reference document:	47 CFR §22.917(a), 47 CFR §2.1051		
Test Requirements:	<p>The power of any emission outside of the authorized operating frequency ranges must be attenuated below the transmitting power (P) by a factor of at least $43 + 10 \log(P)$ dB</p> <p>The radio frequency voltage or powers generated within the equipment and appearing on a spurious frequency shall be checked at the equipment output terminals when properly loaded with a suitable artificial antenna. Curves or equivalent data shall show the magnitude of each harmonic and other spurious emission that can be detected when the equipment is operated under the conditions specified in §2.1049 as appropriate. The magnitude of spurious emissions which are attenuated more than 20 dB below the permissible value need not be specified</p>		
Method of testing:	KDB 935210 D05 v01r02, Conducted		Pass
Operating conditions:	Under normal test conditions		
S.A. Settings:	RBW: minimum 1% of EBW or 100kHz or 1MHz; VBW: 3 times RBW		
Environment conditions:	Ambient Temperature: 22.4°C	Relative Humidity: 57.8%	Atmospheric Pressure: 1011.4 hPa
Test Result:	See below		See Plot 3.4.1 - 3.4.8

*It translates to a limit of -13dBm

Test results:

Modulation	Operating Frequency, MHz		Emission Frequency, MHz	Emission Level, dBm	Limit, dBm	Delta, dB	Pass/Fail
	Carrier 1	Carrier 2					
MSK Gaussian filter 0.3 data rate 270kbps	869.200	NA	869.000	-23.591	-13.00	-10.591	Pass
	869.200	869.400	869.000	-26.739	-13.00	-13.739	Pass
	893.800	NA	894.000	-24.307	-13.00	-11.307	Pass
	893.600	893.800	894.000	-27.065	-13.00	-14.065	Pass
AWGN 4.1MHz	871.500	NA	869.000	-26.941	-13.00	-13.941	Pass
	871.500	876.500	869.000	-27.459	-13.00	-14.459	Pass
	891.500	NA	894.000	-27.010	-13.00	-14.010	Pass
	886.500	891.500	894.000	-28.063	-13.00	-15.063	Pass

Note: The EUT tested at 0.5 dB below AGC threshold level and 3 dB above AGC threshold level, and worst case results were presented.

Note: Only at MSK modulation (GSM) the Composite Output Power transmission is 38 dBm.

Plot 3.4.1: Band Edge test results, MSK Gaussian filter 0.3 data rate 270kbps, Fc = 869.200 MHz, single test signal

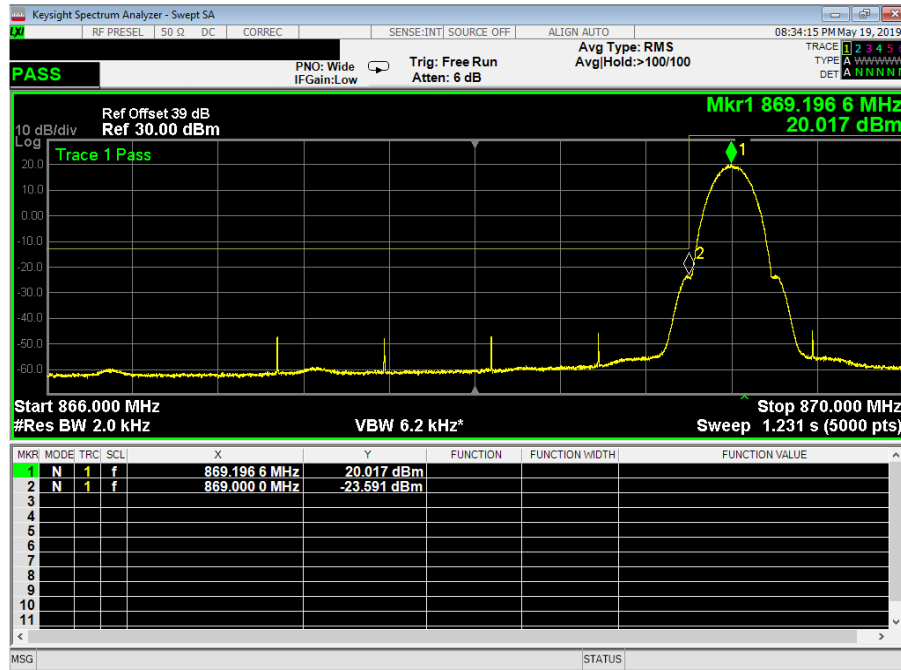

Plot 3.4.2: Band Edge test results, MSK Gaussian filter 0.3 data rate 270kbps, Fc = 869.200 + 869.400 MHz, two test signals

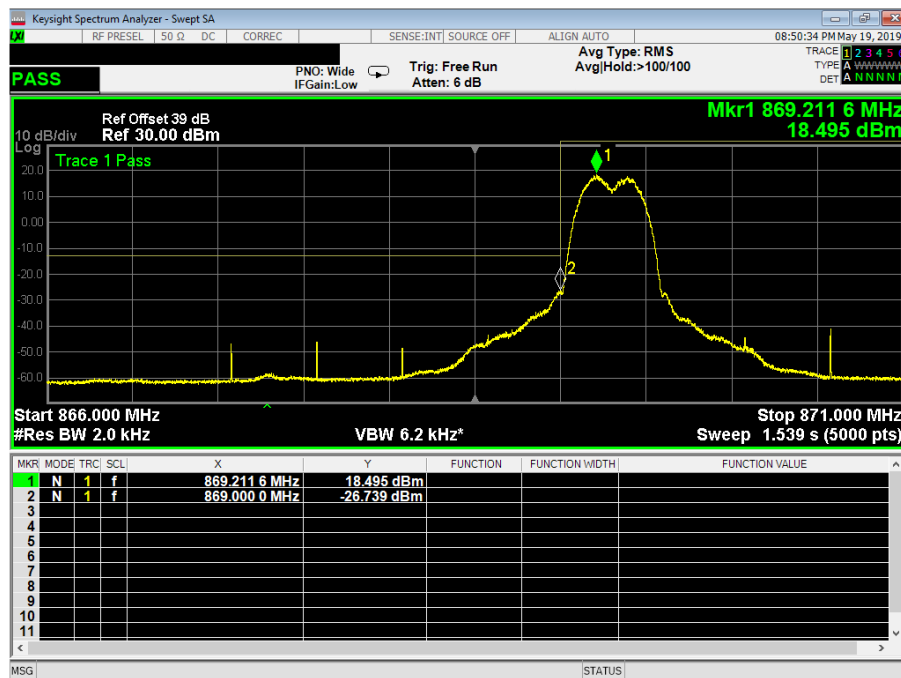

Plot 3.4.3: Band Edge test results, MSK Gaussian filter 0.3 data rate 270kbps, Fc = 893.800 MHz, single test signal

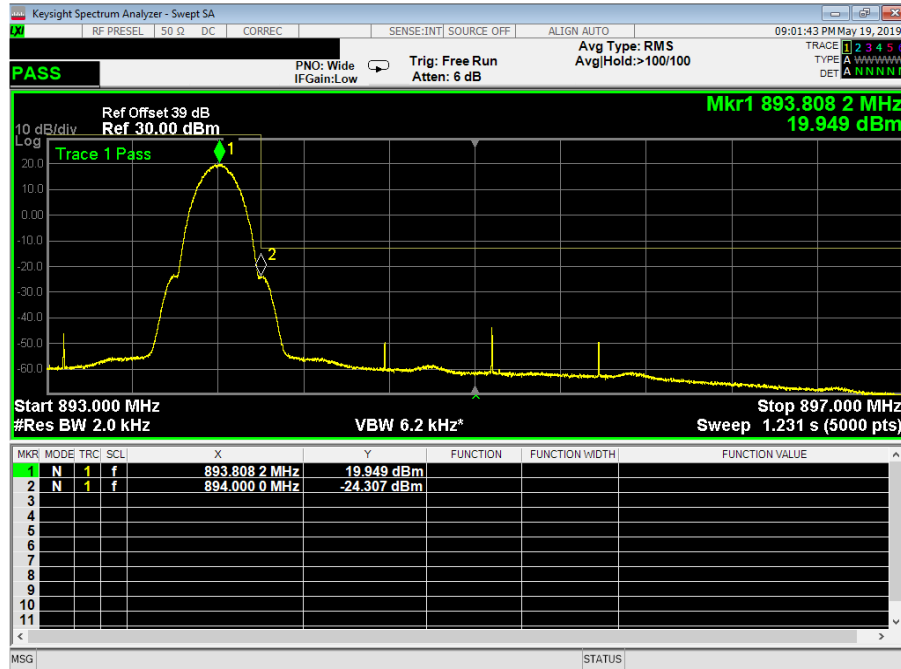

Plot 3.4.4: Band Edge test results, MSK Gaussian filter 0.3 data rate 270kbps, Fc = 893.600 + 893.800 MHz, two test signals

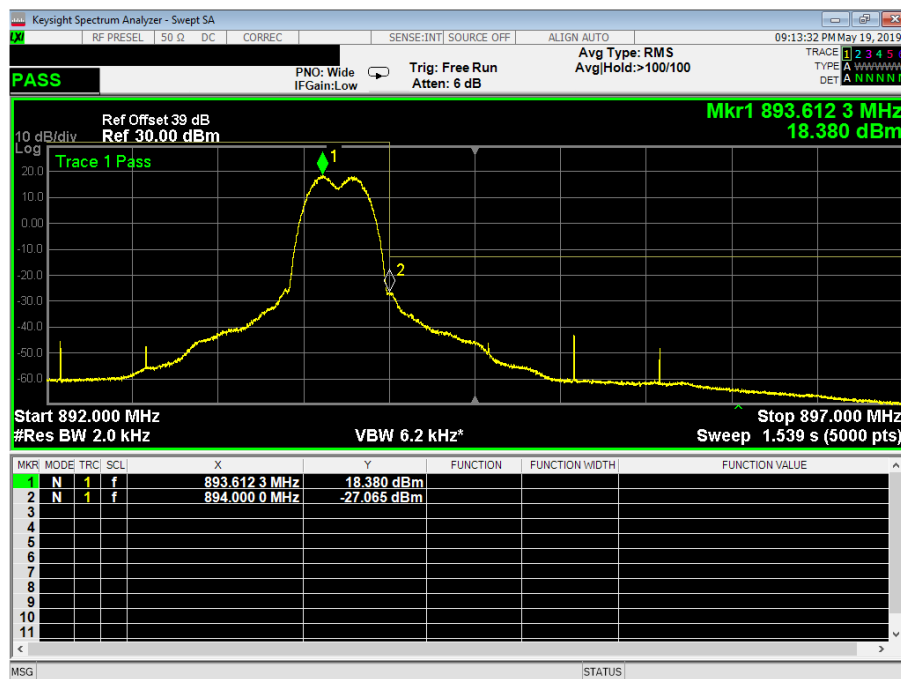

**Plot 3.4.5: Band Edge test results, AWGN 4.1MHz,
Fc = 871.500 MHz, single test signal**

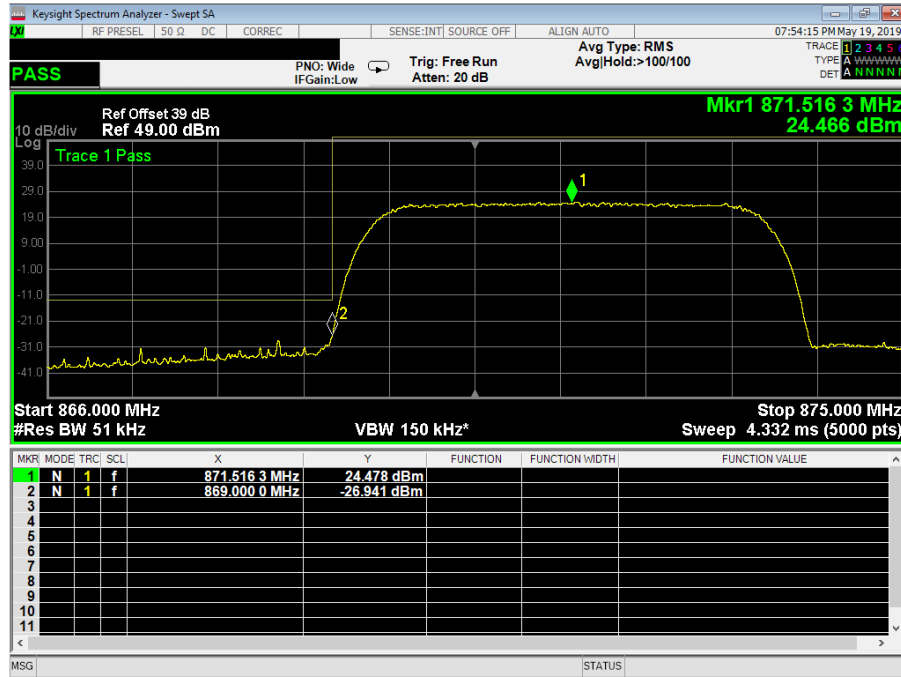

**Plot 3.4.6: Band Edge test results, AWGN 4.1MHz,
Fc = 871.500 + 876.500 MHz, two test signals**

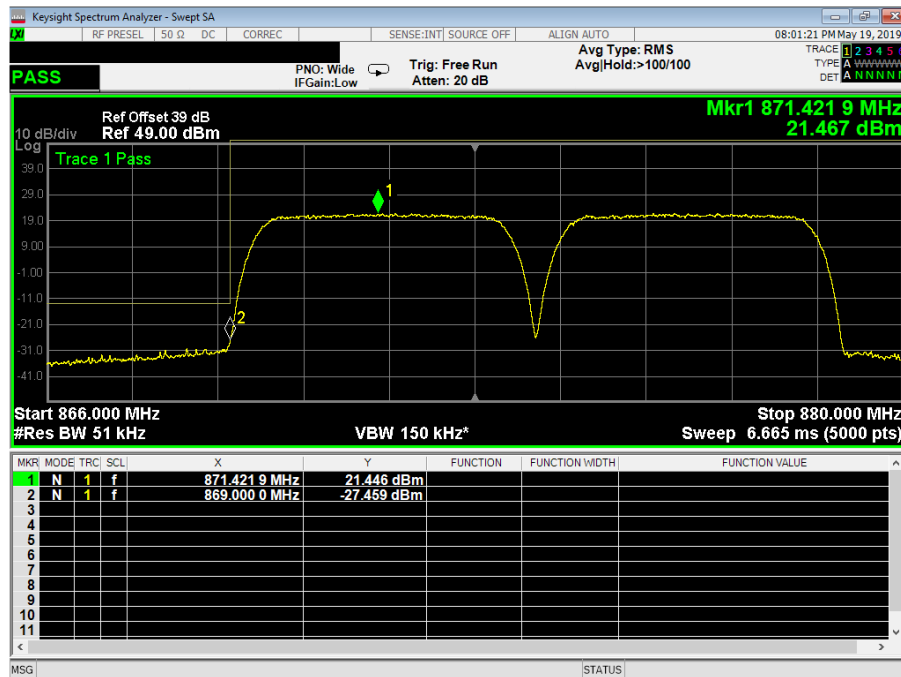

**Plot 3.4.7: Band Edge test results, AWGN 4.1MHz,
Fc = 891.500 MHz, single test signal**

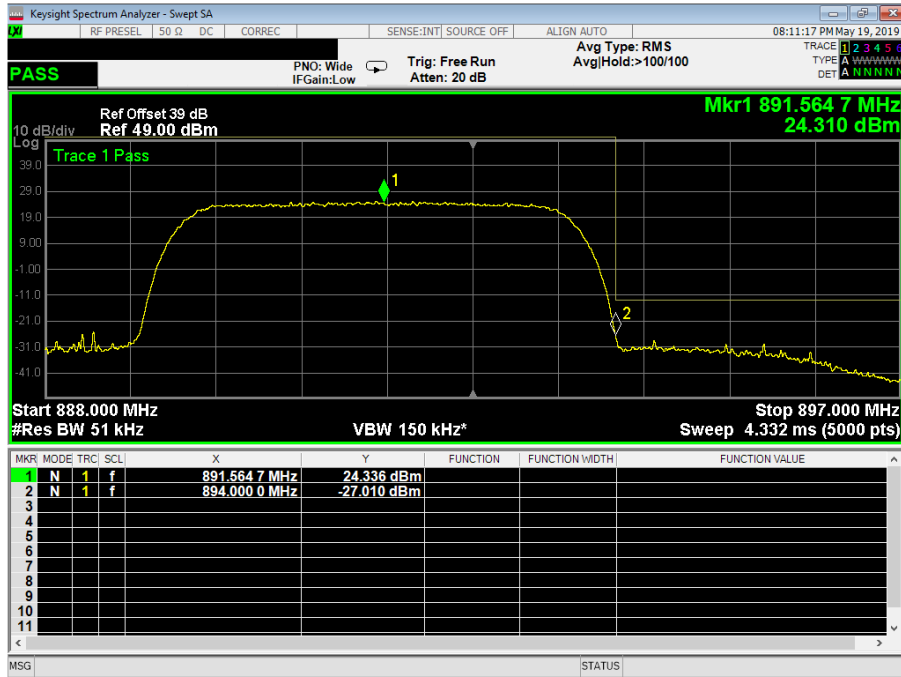

**Plot 3.4.8: Band Edge test results, AWGN 4.1MHz,
Fc = 886.500 + 891.500 MHz, two test signals**

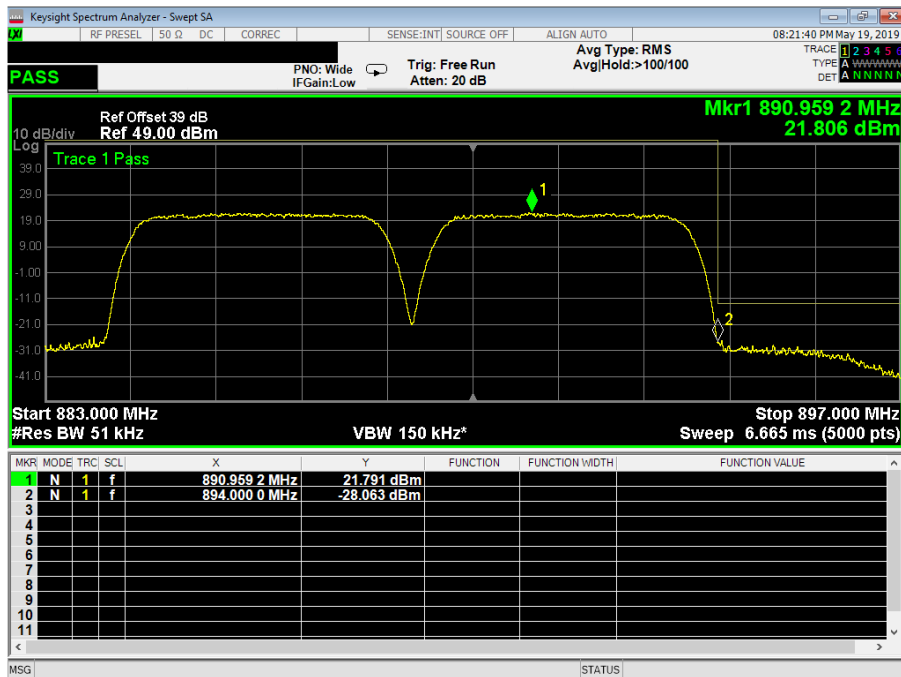

3.5. Spurious Emission Conducted Measurement

Reference document:	47 CFR §22.917, §2.1051		
Test Requirements:	<p>Out of band emissions. The power of any emission outside of the authorized operating frequency ranges must be attenuated below the transmitting power (P) by a factor of at least $43 + 10 \log(P)$ dB</p> <p>The radio frequency voltage or powers generated within the equipment and appearing on a spurious frequency shall be checked at the equipment output terminals when properly loaded with a suitable artificial antenna. Curves or equivalent data shall show the magnitude of each harmonic and other spurious emission that can be detected when the equipment is operated under the conditions specified in §2.1049 as appropriate. The magnitude of spurious emissions which are attenuated more than 20 dB below the permissible value need not be specified</p>		
Method of testing:	KDB 935210 D05 v01r02, Conducted	Pass	
Operating conditions:	Under normal test conditions		
S.A. Settings:	RBW: 1MHz, VBW: 3MHz		
Environment conditions:	Ambient Temperature: 22.4°C	Relative Humidity: 56.8%	Atmospheric Pressure: 1011.4 hPa
Test Result:	See below	See Plot 3.5.1 - Plot 3.5.12	

*It translates to a limit of -13dBm

Test Results:

Modulation	Operating Frequency, MHz	Emission Frequency, MHz	Emission Level, dBm	Limit, dBm	Delta, dB	Pass/Fail
MSK Gaussian filter 0.3 data rate 270kbps	869.200	All emissions were at least 15dB below the Limit				Pass
	881.500	All emissions were at least 15dB below the Limit				Pass
	893.800	All emissions were at least 15dB below the Limit				Pass
AWGN 4.1MHz	871.500	All emissions were at least 15dB below the Limit				Pass
	881.500	All emissions were at least 15dB below the Limit				Pass
	891.500	All emissions were at least 15dB below the Limit				Pass

Note: Only at MSK modulation (GSM) the Composite Output Power transmission is 38 dBm.

Plot 3.5.1: Spurious Emission Conducted Measurement, MSK Gaussian filter 0.3 data rate 270kbps, Fc = 869.200 MHz, 9 kHz – 1.3 GHz

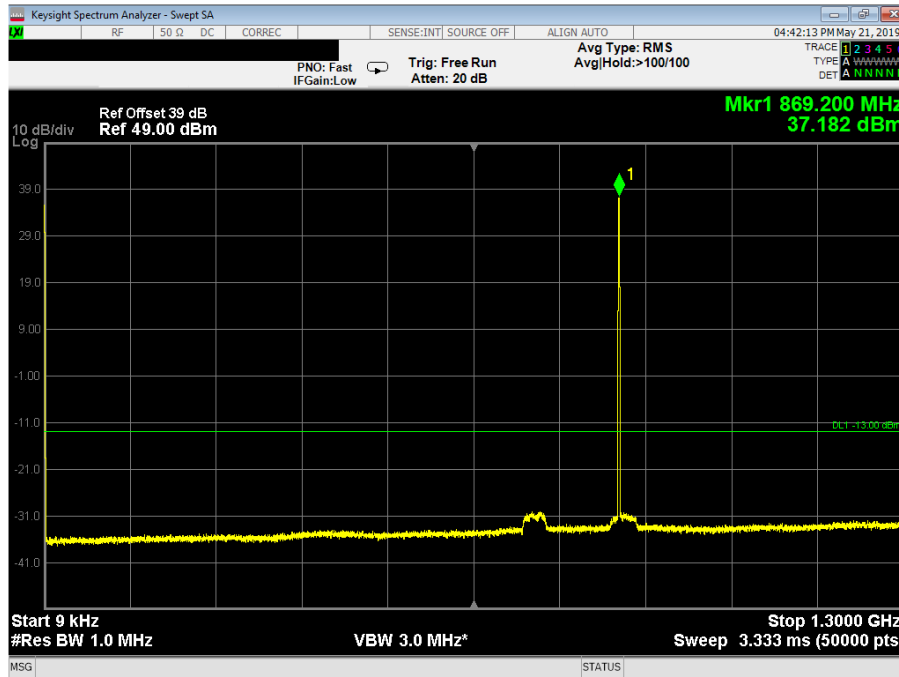

Plot 3.5.2: Spurious Emission Conducted Measurement, MSK Gaussian filter 0.3 data rate 270kbps, Fc = 869.200 MHz, 1.3 GHz – 10.0 GHz

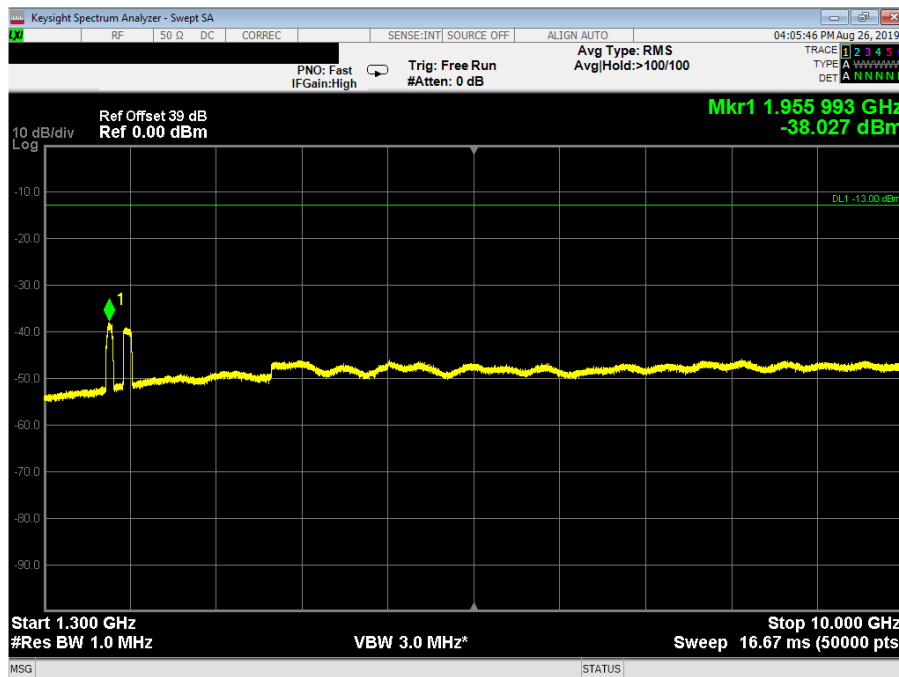

With highpass filter WHKX10-1010-1200-15000-40EF

Plot 3.5.3: Spurious Emission Conducted Measurement, MSK Gaussian filter 0.3 data rate 270kbps, Fc = 881.500, 9 kHz – 1.3 GHz

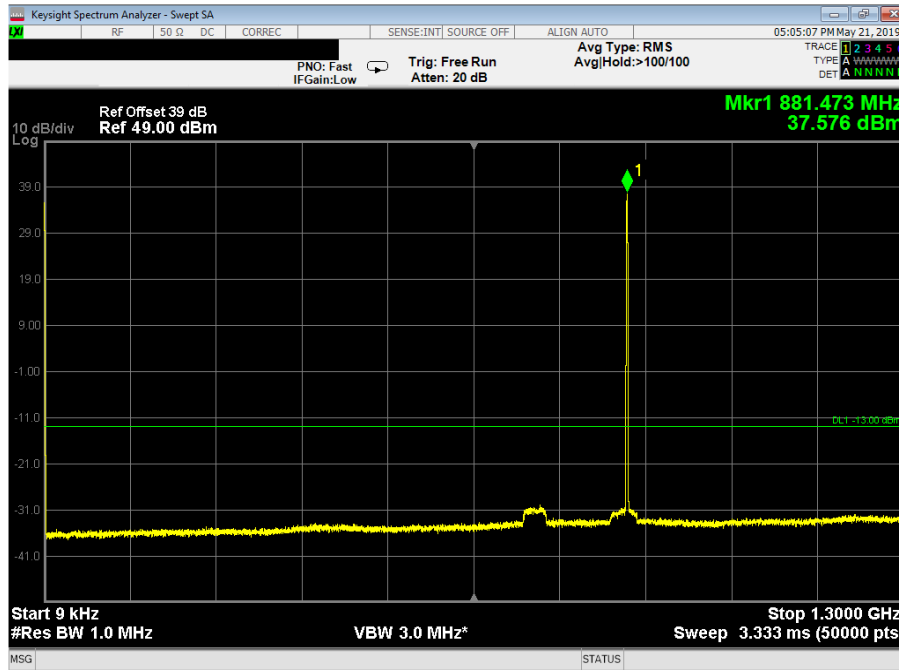

Plot 3.5.4: Spurious Emission Conducted Measurement, MSK Gaussian filter 0.3 data rate 270kbps, Fc = 881.500, 1.3 GHz – 10.0 GHz

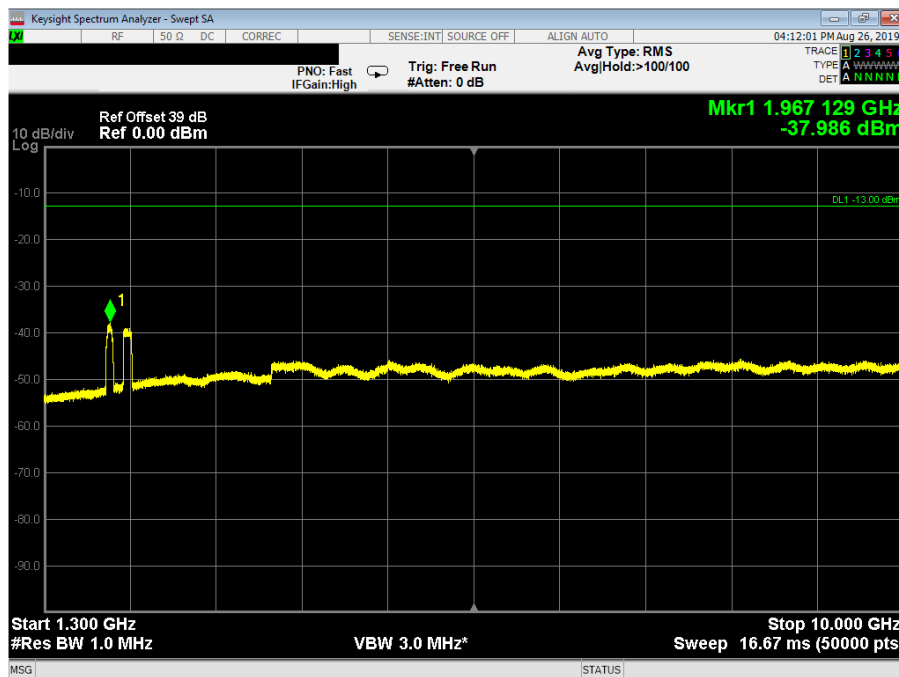

With hignpass filter WHKX10-1010-1200-15000-40EF

**Plot 3.5.5: Spurious Emission Conducted Measurement, MSK Gaussian filter 0.3 data rate 270kbps
Fc = 893.800 MHz, 9 kHz – 1.3 GHz**

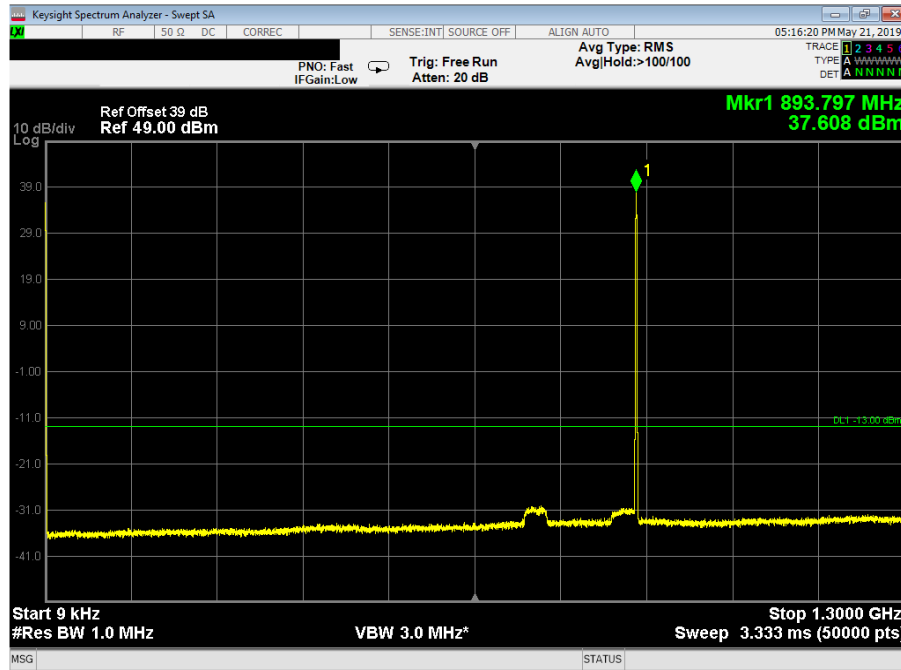

**Plot 3.5.6: Spurious Emission Conducted Measurement, MSK Gaussian filter 0.3 data rate 270kbps,
Fc = 893.800 MHz, 1.3 GHz – 10.0 GHz**

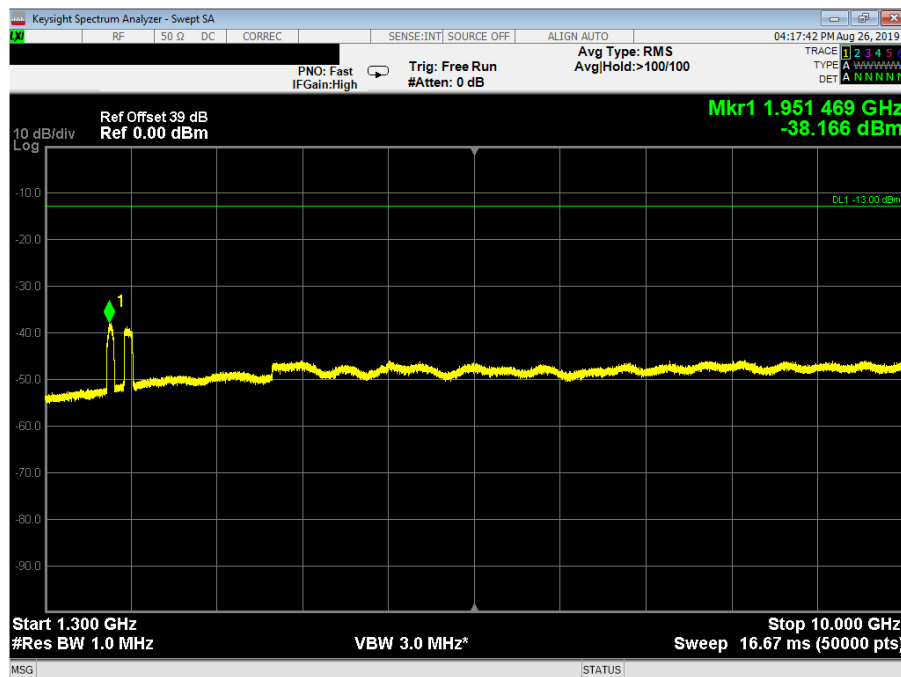

With hignpass filter WHKX10-1010-1200-15000-40EF

**Plot 3.5.7: Spurious Emission Conducted Measurement, AWGN 4.1MHz,
Fc = 871.500 MHz, 9 kHz – 1.3 GHz**

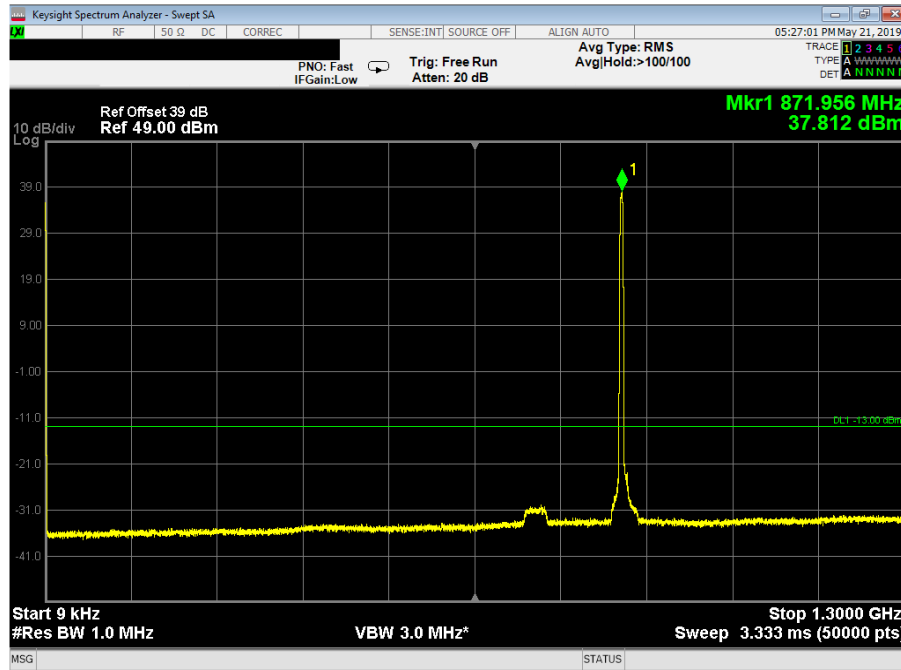

**Plot 3.5.8: Spurious Emission Conducted Measurement, AWGN 4.1MHz,
Fc = 871.500 MHz, 1.3 GHz – 10.0 GHz**

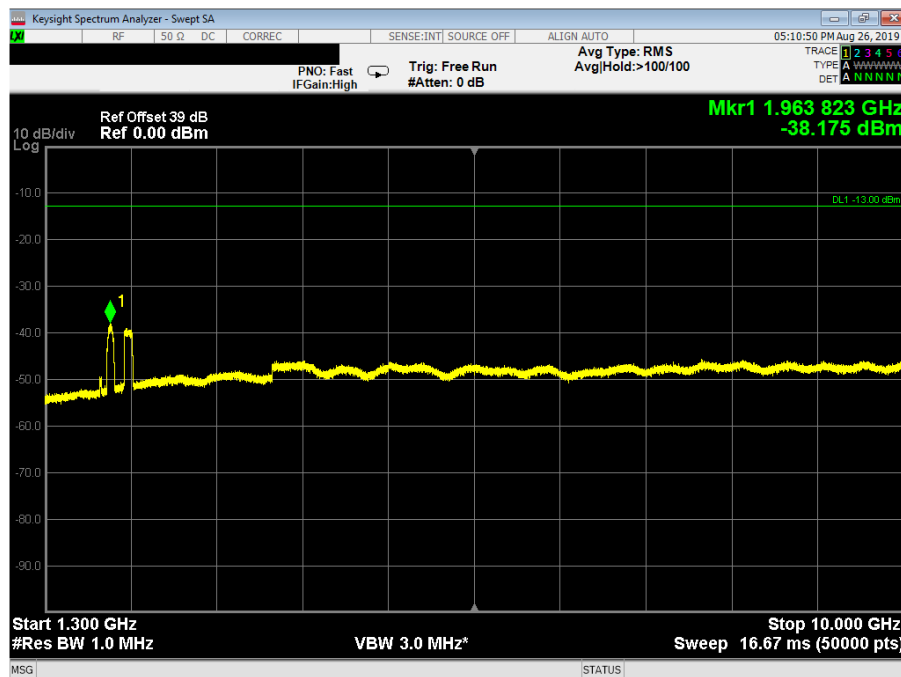

With hignpass filter WHKX10-1010-1200-15000-40EF

**Plot 3.5.9: Spurious Emission Conducted Measurement, AWGN 4.1MHz,
Fc = 881.500 MHz, 9 kHz – 1.3 GHz**

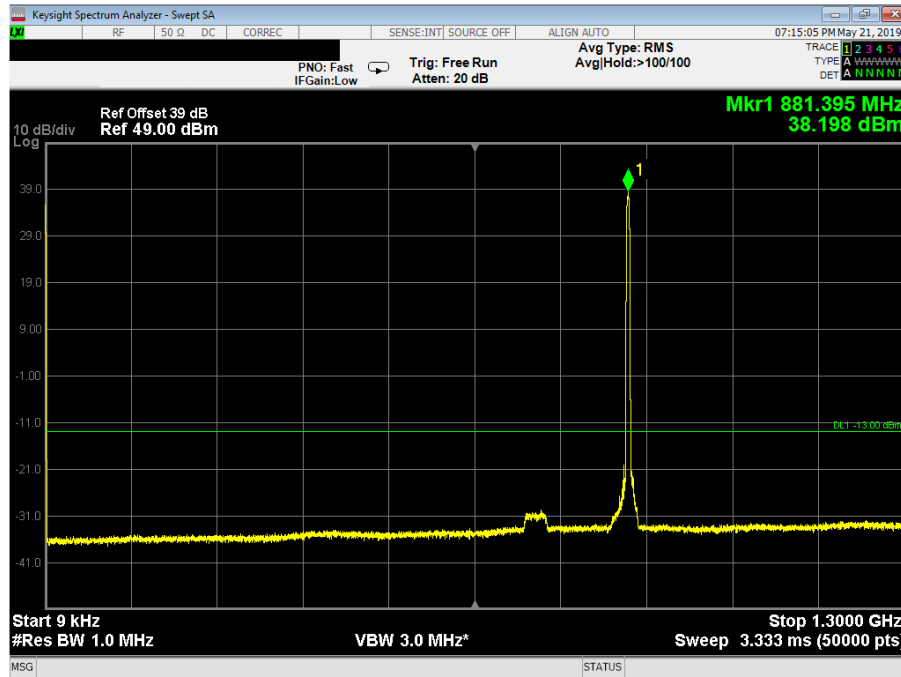

**Plot 3.5.10: Spurious Emission Conducted Measurement, AWGN 4.1MHz,
Fc = 881.500 MHz, 1.3 GHz – 10.0 GHz**

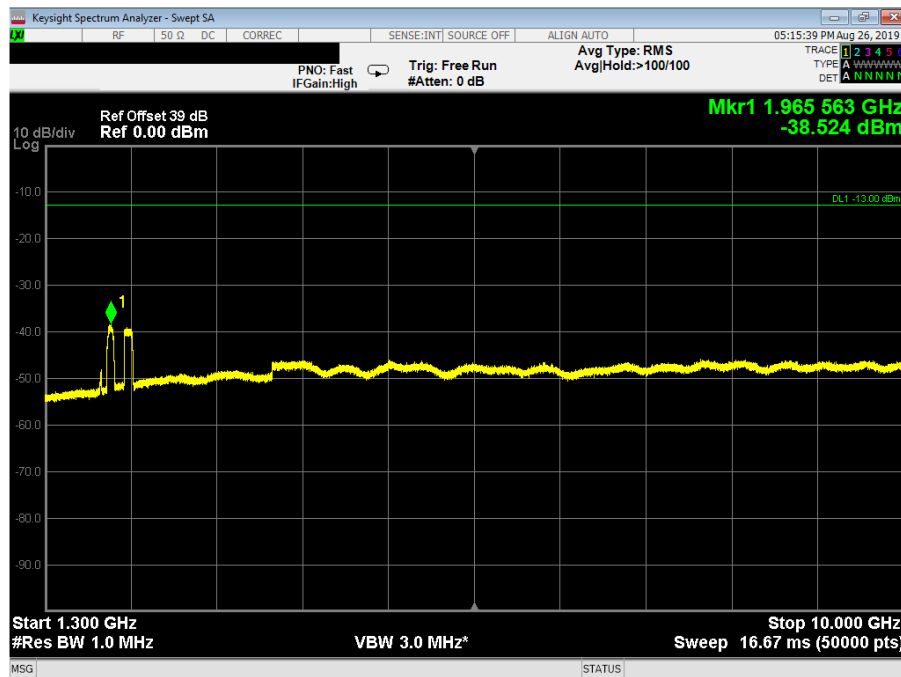

With highpass filter WHKX10-1010-1200-15000-40EF

**Plot 3.5.11: Spurious Emission Conducted Measurement, AWGN 4.1MHz,
Fc = 891.500 MHz, 9 kHz – 1.3 GHz**

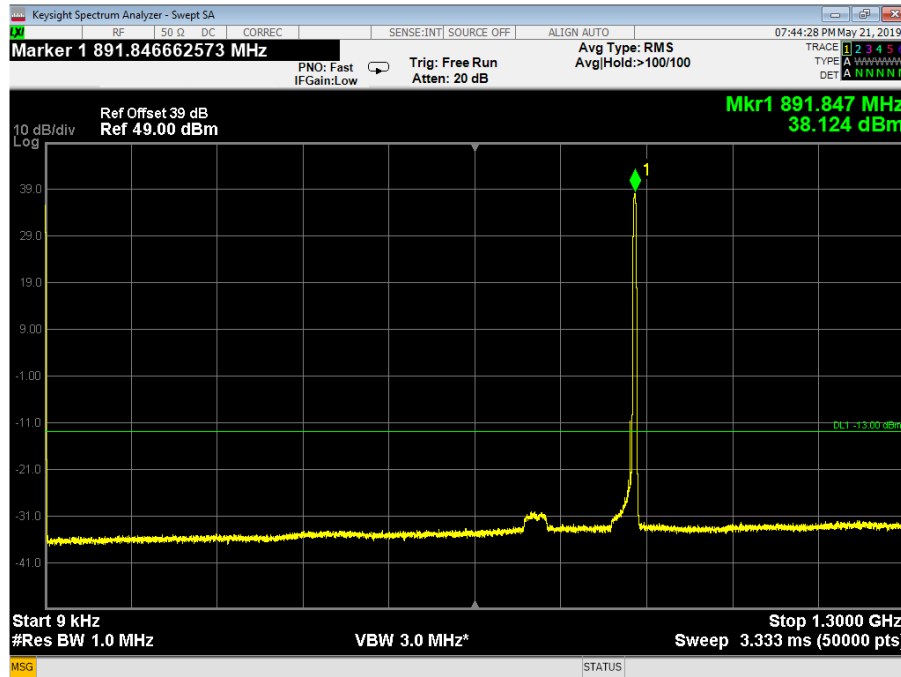

**Plot 3.5.12: Spurious Emission Conducted Measurement, AWGN 4.1MHz,
Fc = 891.500, 1.3 GHz – 10.0 GHz**

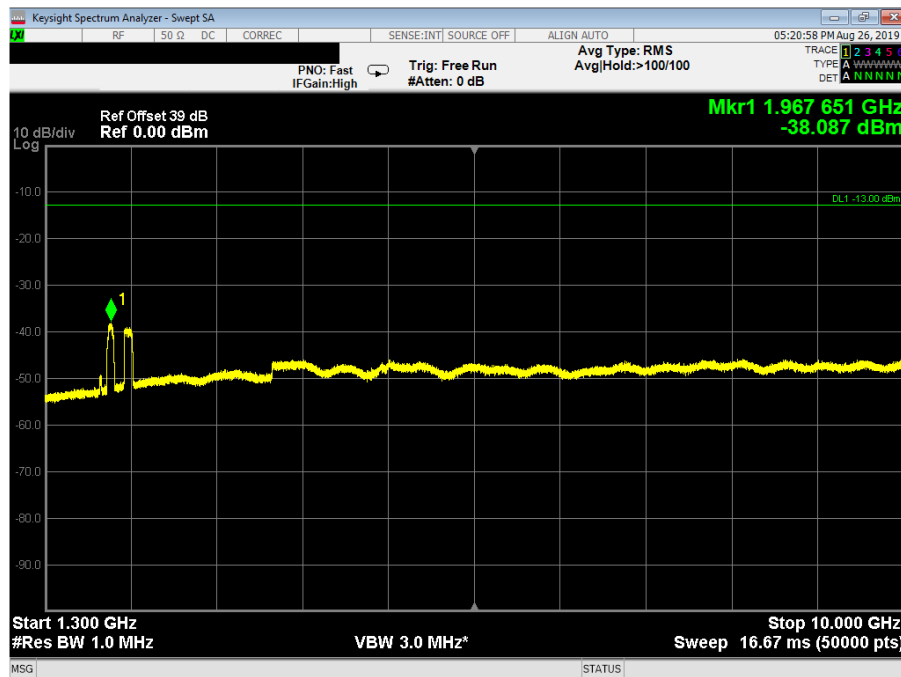

With higpass filter WHKX10-1010-1200-15000-40EF

3.6. Spurious Emissions, Radiated Measurements

Reference document:	47 CFR §22.917 & §2.1053		
Test Requirements:	The power of any emission outside of the authorized operating frequency block shall be attenuated below the transmitting power (P, in Watts) by a factor of at least 43+10log(P) dB*.		
Method of testing:	KDB 935210 D05v01r01, Radiated KDB 971168[R8]	Pass	
Operating conditions:	Under normal test conditions		
S.A. Settings:	RBW: 1MHz, VBW: 3MHz		
Environment conditions:	Ambient Temperature: 22°C	Relative Humidity: 58.8%	Atmospheric Pressure: 1011.4 hPa
Test Result:	See below	See Plots 3.6.1- 3.6.12	

*It translates to a limit of -13dBm = 84 dBµV/m @3m distance

Note 1: All measurements performed with 2 simultaneous transmissions:

Low frequency: 746.2 MHz, 869.2 MHz

Middle frequency: 751.5 MHz, 881.5 MHz

High frequency: 756.8 MHz, 893.8 MHz

Note 2: All measurements done in horizontal and vertical polarizations; the table below shows the worst case.

Test Results:

Frequency, MHz	Emission Level, dBµV/m	Antenna Polarization	Substitution Method				Limit [dBm]	Margin, dB	Pass/Fail	Ref Plots
			Signal generator output, [dBm]	Antenna Gain, [dBi]	Cable Loss, dB	Calculated EIRP*, [dBm]				
Low Frequency										
All emissions were at least 15dB below the Limit								Pass	3.6.1-3.6.4	
Middle Frequency										
All emissions were at least 15dB below the Limit								Pass	3.6.5-3.6.8	
High Frequency										
All emissions were at least 15dB below the Limit								Pass	3.6.9-3.6.12	

*Calculated EIRP [dBm] = Signal Generator Output [dBm] + Antenna Gain [dBi] – Cable Loss [dB]

Plot 3.6.1: Spurious Emissions test results, 30 MHz – 1 GHz range, Horizontal polarization, Low Frequency



Plot 3.6.2: Spurious Emissions test results, 30 MHz – 1 GHz range, Vertical polarization, Low Frequency

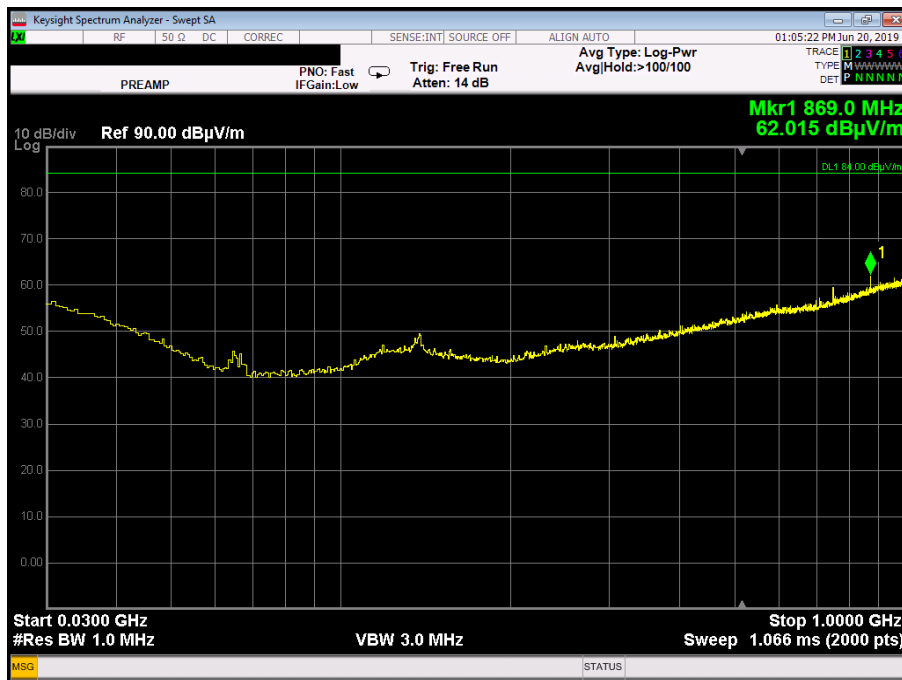

Plot 3.6.3: Spurious Emissions test results, 1 GHz – 18 GHz range, Horizontal polarization, Low Frequency

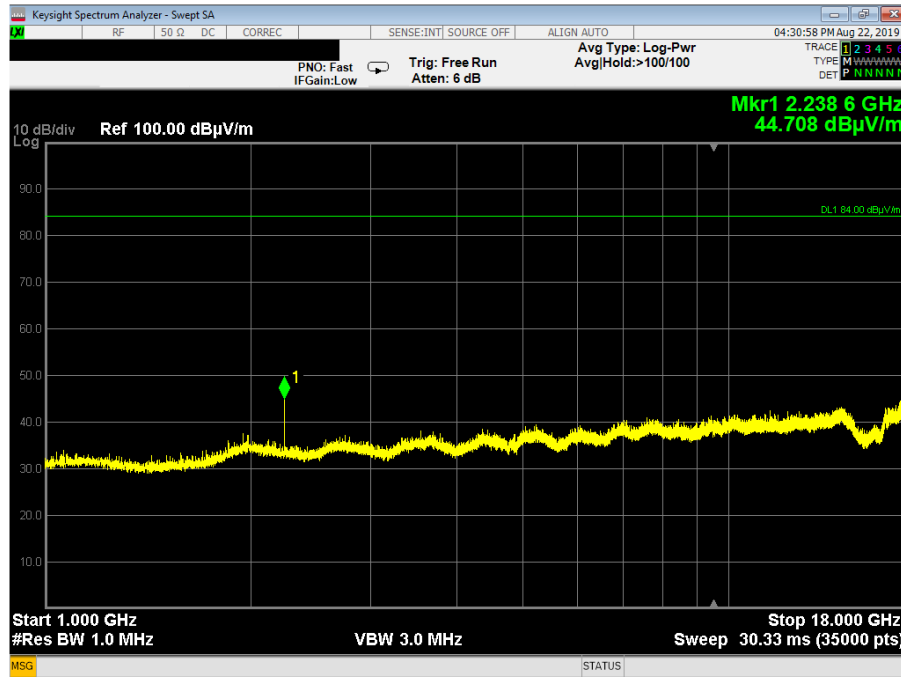

Plot 3.6.4: Spurious Emissions test results, 1 GHz – 18 GHz range, Vertical polarization, Low Frequency

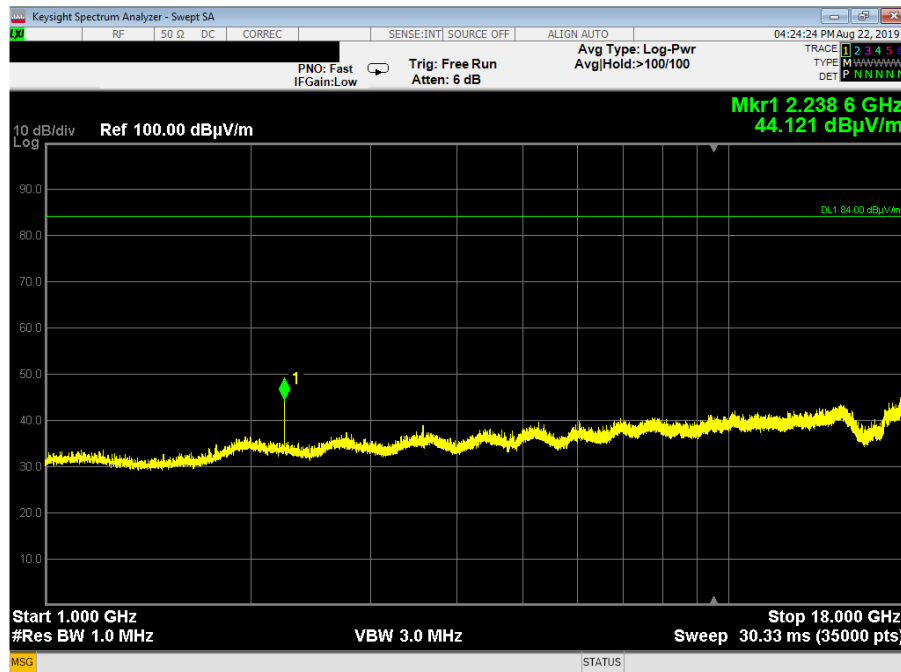

Plot 3.6.5: Spurious Emissions test results, 30 MHz – 1 GHz range, Horizontal polarization, Middle Frequency

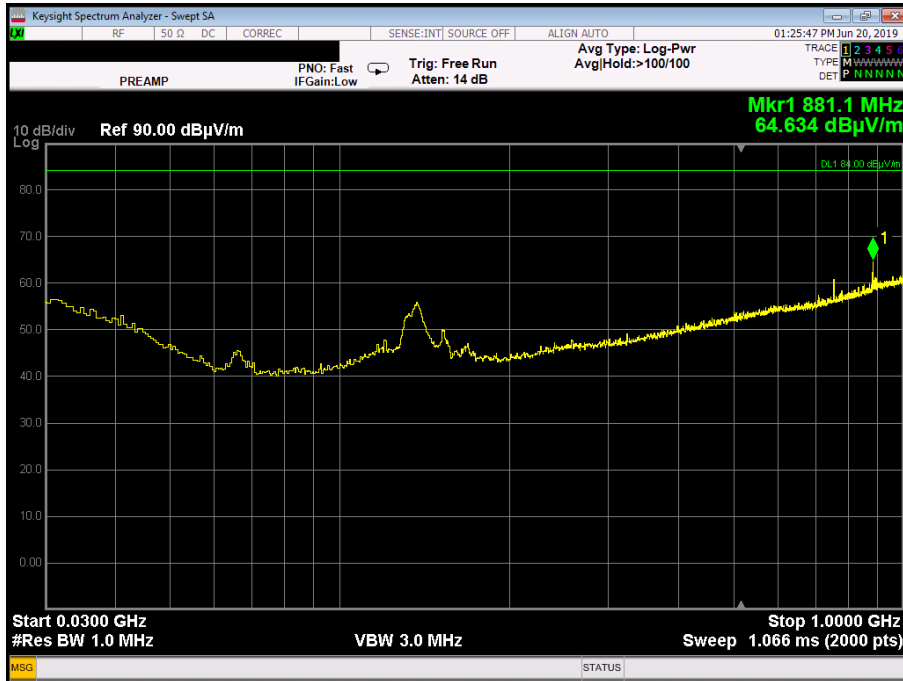

Plot 3.6.6: Spurious Emissions test results, 30 MHz – 1 GHz range, Vertical polarization, Middle Frequency



Plot 3.6.9: Spurious Emissions test results, 30 MHz – 1GHz range, Horizontal polarization, High Frequency

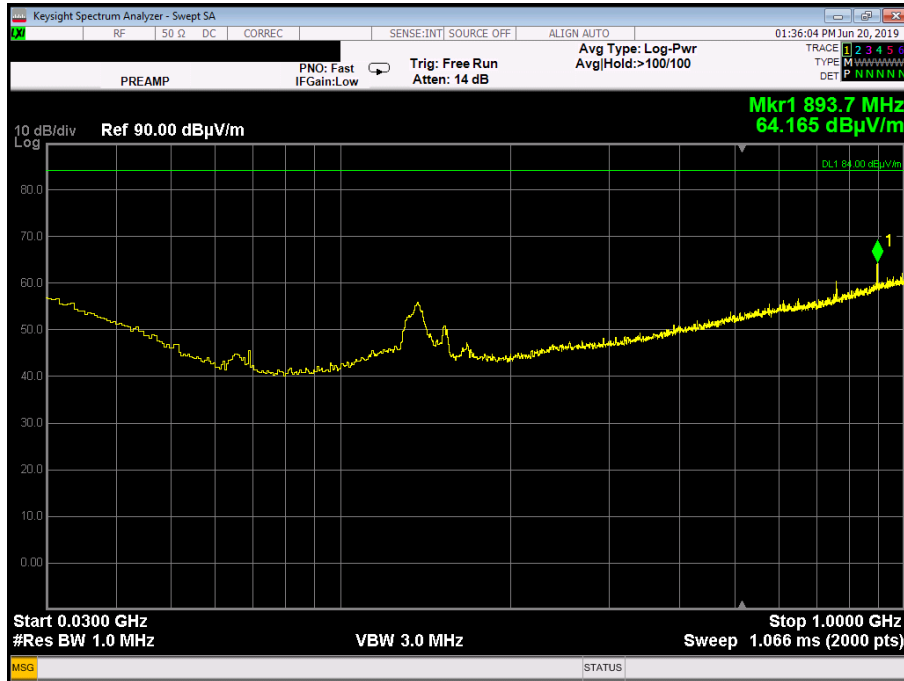

Plot 3.6.10: Spurious Emissions test results, 30 MHz – 1GHz range, Vertical polarization, High Frequency

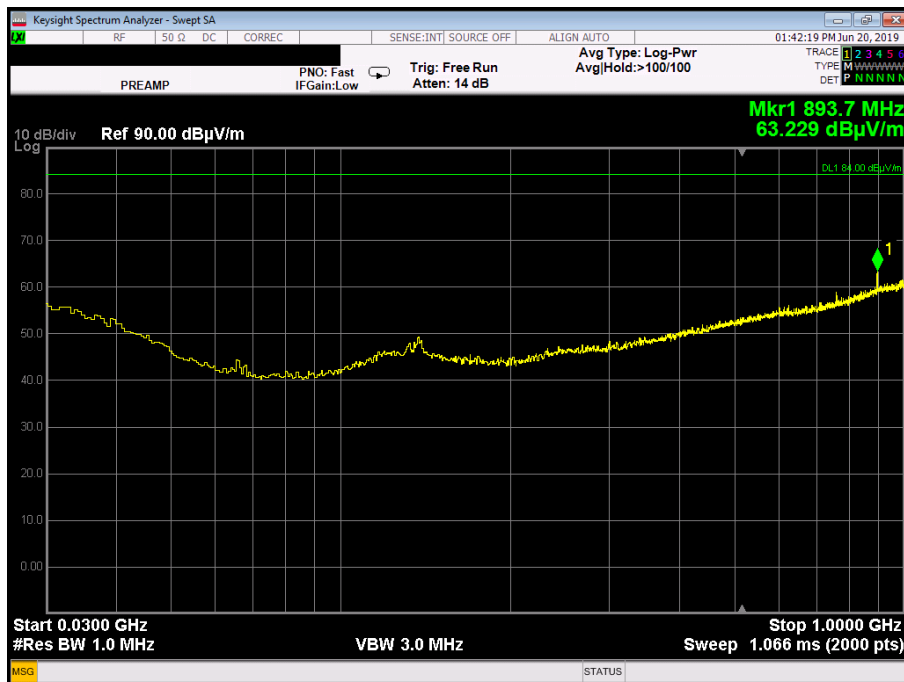

3.7. Frequency stability

Reference document:	47 CFR §22.355, 47 CFR §2.1055		
Test Requirements:	The frequency stability shall be sufficient to ensure that the fundamental emission stays within the authorized frequency block.		
Method of testing:	KDB 935210 D05 v01r02, Conducted	Pass	
Operating conditions:	Under normal and extremes test conditions		
Environment conditions:	Ambient Temperature: 22.7°C	Relative Humidity: 59.8%	Atmospheric Pressure: 1011.4 hPa
Test Result:	See below	-	

Test results - Fc= 881.500 MHz

Frequency error vs. Voltage: AC Model

Voltage [V _{AC}]	Frequency Error [Hz]	Frequency Error [%]	Frequency Error [ppm]	Limit [ppm]	Test Result
Carrier frequency at 20°C (120 V _{AC}): Fc = 881.500140 MHz					
102-138	No frequency error observed				Pass

Frequency error vs. Temperature: AC Model

Temperature, °C	Reference Frequency, MHz	Measured Frequency, MHz	Frequency Error, Hz	Frequency Error, ppm	Limit, ppm	Delta	Pass/Fail
-30	881.500140	881.500100	40.00	0.020382	1.50	-1.48	Pass
-20	881.500140	881.500120	20.00	0.010191	1.50	-1.49	Pass
-10	881.500140	881.500120	20.00	0.010191	1.50	-1.49	Pass
0	881.500140	881.500110	30.00	0.015287	1.50	-1.48	Pass
10	881.500140	881.500120	20.00	0.010191	1.50	-1.49	Pass
20	Reference temperature						
30	881.500140	881.500130	10.00	0.005096	1.50	-1.49	Pass
40	881.500140	881.500120	20.00	0.010191	1.50	-1.49	Pass
50	881.500140	881.500120	20.00	0.010191	1.50	-1.49	Pass

4. Appendix

Appendix A: List of test equipment used

Description	Manufacturer	Model	Serial No.	Last Cal	Cal Due
Anechoic new (large) chamber	-----	-----	-----	21/03/2018	21/03/2020
Environmental Test Chamber	TENNEY ENGINEERING	TTRS	10.158-5	10/10/2018	10/10/2019
MXE EMI RECEIVER 3Hz-44GHz	Keysight Technologies	N9038A	MY55420200	06/04/2019	06/04/2020
MXE EMI RECEIVER 3Hz-44GHz	Keysight Technologies	N9038A	MY56400070	08/04/2019	08/04/2020
Power Meter	Agilent	N1911A	MY45100784	20/03/2019	20/03/2021
Wideband Power Sensor	Agilent	N1921A	MY45241242	20/03/2019	20/03/2021
Highpass Filter, 1.2GHz - 15GHz	WAINWRIGHT	WHKX10-1010-1200-15000-40EF	1	04/11/2018	04/11/2019
Bilog Antenna 30MHz – 1000MHz	Teseq	CBL 6141B	34119	18/03/2019	18/03/2022
Horn Antenna 1GHz - 18GHz	A.R.A	DRG-118/A	17188	17/09/2018	17/09/2019
Low Noise Amplifier 1GHz - 18GHz	Spacek Labs	SL1018-56-5	17J29	31/01/2019	31/01/2020

Appendix B: Accreditation Certificate



Accredited Laboratory

A2LA has accredited

QUALITECH

Petah-Tikva, Israel

for technical competence in the field of

Electrical Testing

This laboratory is accredited in accordance with the recognized International Standard ISO/IEC 17025:2005 *General requirements for the competence of testing and calibration laboratories*. This accreditation demonstrates technical competence for a defined scope and the operation of a laboratory quality management system (refer to joint ISO-ILAC-IAF Communiqué dated April 2017).



Presented this 31st day of May 2018.

A handwritten signature in black ink, appearing to be 'L. Ben', written over a horizontal line.

President and CEO
For the Accreditation Council
Certificate Number 1633.01
Valid to June 30, 2020

For the tests to which this accreditation applies, please refer to the laboratory's Electrical Scope of Accreditation.

End of the Test Report