



RADIO TEST REPORT

FOR

AXELL WIRELESS

ON

DR3307-3308

DIGITAL MULTI-BAND REPEATER

DOCUMENT NO. TRA-007383-00-W-US1

TEST REPORT NO: TRA-007383-00-W-US1
COPY NO: 1
ISSUE NO: 1
FCC ID: NEO-DFR-CELL-3380

**REPORT ON THE CERTIFICATION TESTING OF A
AXELL WIRELESS
DR3307-3308
DIGITAL MULTI-BAND REPEATER
WITH RESPECT TO
THE FCC RULES CFR 47,
PART 22**

TEST DATE: 21st - 28th October 2011

testing regulatory and compliance



APPROVED BY:

J CHARTERS
RADIO
PRODUCT
MANAGER

DATE: 21st November 2011

Distribution:

- Copy Nos: 1. Axell Wireless
2. TRaC Global

THIS DOCUMENT MAY BE REPRODUCED ONLY IN ITS ENTIRETY AND WITHOUT CHANGE

CONTENTS

	PAGE
CERTIFICATE OF CONFORMITY & COMPLIANCE	4
APPLICANT'S SUMMARY	5
EQUIPMENT TEST CONDITIONS	6
TESTS REQUIRED	6
TEST RESULTS	7 – 94

	ANNEX
PHOTOGRAPHS	A
APPLICANT'S SUBMISSION OF DOCUMENTATION LIST	B
EQUIPMENT CALIBRATION	C
MEASUREMENT UNCERTAINTY	D

Notes:

- | | | | |
|----|---|-----|-----|
| 1. | Component failure during test | YES | [] |
| | | NO | [X] |
| 2. | If Yes, details of failure: | | |
| 3. | The facilities used for the testing of the product contain in this report are FCC Listed. | | |

CERTIFICATE OF CONFORMITY & COMPLIANCE

FCC IDENTITY: NEO-DFR-CELL-3380

PURPOSE OF TEST: Certification

TEST SPECIFICATION: FCC RULES CFR 47, Part 22

TEST RESULT: Compliant to Specification

EQUIPMENT UNDER TEST: DR3307-3308 Digital Multi-Band Repeater

EQUIPMENT TYPE: Private Land Mobile Repeater

MAXIMUM GAIN: Uplink = 81.23 dB
Downlink = 81.44 dB

MAXIMUM INPUT: Uplink = -52 dBm
Downlink = -46 dBm

MAXIMUM OUTPUT CONDUCTED: Uplink = 27.51 dBm
Downlink = 34.13 dBm

NUMBER OF CHANNELS: Software selectable between 1 and 12

CHANNEL BANDWIDTH: Upto 20MHz per single channel, programmable

FREQUENCY GENERATION: N/A

MODULATION TYPE: CDMA, W-CDMA, GSM

POWER SOURCE(s): +110Vac

TEST DATE(s): 21st - 28th October 2011

APPLICANT: Axell Wireless

ADDRESS: Aerial House
Asheridge Road
Chesham
Buckinghamshire
HP5 1TU

TESTED BY: S. BHARAT



APPROVED BY:

J. CHARTERS
RADIO
PRODUCT
MANAGER

APPLICANT'S SUMMARY

EQUIPMENT UNDER TEST (EUT): DR3307-3308 Digital Multi-Band Repeater

EQUIPMENT TYPE: Private Land Mobile Repeater

PURPOSE OF TEST: Certification

TEST SPECIFICATION(s): FCC RULES CFR 47, Part 90

TEST RESULT: COMPLIANT Yes
No

APPLICANT'S CATEGORY: MANUFACTURER
IMPORTER
DISTRIBUTOR
TEST HOUSE
AGENT

APPLICANT'S CONTACT PERSON(s): Mr Peter Bradfield

E-mail address: peter.bradfield@axellwireless.com

APPLICANT: Axell Wireless

ADDRESS: Aerial House
Asheridge Road
Chesham
Buckinghamshire
HP5 1TU
United Kingdom

TEL: +44 (0)1494 777000

FAX: +44 (0)1494 778456

MANUFACTURER: Axell Wireless

EUT(s) COUNTRY OF ORIGIN: United Kingdom

TEST LABORATORY: TRaC Global

TEST DATE(s): 21st - 28th October 2011

TEST REPORT No: TRA-007383-00-W-US1

EQUIPMENT TEST / EXAMINATIONS REQUIRED

1.	TEST/EXAMINATION	RULE PART	APPLICABILITY	RESULT
	RF Power Output	22.913	Yes	Complies
	Audio Frequency Response	TIA EIA-603.3.2.6	N/A	N/A
	Audio Low-Pass Filter Response	TIA EIA-603.3.2.6	N/A	N/A
	Modulation Limiting	TIA EIA-603.3.2.6	N/A	N/A
	Occupied Bandwidth	22.359	Yes	Complies
	Spurious Emissions at Antenna Terminals	22.359 & 22.917	Yes	Complies
	Field Strength of Spurious Emissions	22.359 & 22.917	Yes	Complies
	Frequency Stability	22.359 & 22.917	N/A(note 1)	N/A
	Transient behaviour	N/A	N/A(note 2)	N/A

Notes:

1 The EUT does not contain modulation circuitry, therefore the test was not performed.

2 The EUT is not a keyed carrier system, therefore the test was not performed.

2. Product class: Uplink Class A [] Class B [X]
Downlink Class A [] Class B [X]
3. Product Use: Private Land Mobile Repeater
4. Emission Designator: F9W, GXW
5. Temperatures: Ambient (Tnom) 22°C
6. Supply Voltages: Vnom +110Vac
- Note: Vnom voltages are as stated above unless otherwise shown on the test report page
7. Equipment Category: Single channel []
Two channel []
Multi-channel [X]
8. Channel spacing: Narrowband Uplink
Narrowband Downlink
9. Test Location TRaC Global Skelmersdale [X]
Hull []
10. Modifications made during test program No modifications were performed.

System description:

The Digital Multi-Band Repeater is a Private Land Mobile Repeater designed to meet North American requirements. In the 850MHz Cellular band, the uplink operates over 824.0 MHz to 849.0MHz and the downlink operates over 869.0MHz to 894MHz. There are up to 12 programmable sub bands. Each sub band can be set to a maximum of 20MHz wide by setting start and stop frequencies.

COMPLIANCE TESTS

AMPLIFIER GAIN – CONDUCTED – UPLINK

Ambient temperature = 22°C
 Relative humidity = 43%
 Supply voltage = +110Vac
 Channel number = See test results

Radio Laboratory

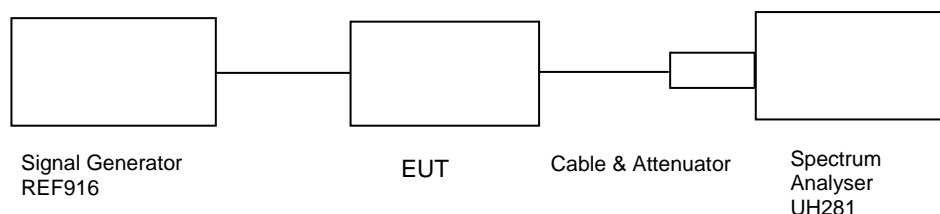

The EUT was set up as shown above. The signal generator level was increased in steps of 1dB till compression point was reached, wherein there was no corresponding increase in output for a known increase in input. The level on the signal generator was noted along with the output level. The input was then increased by 10dB and the corresponding output level was recorded. The system was calibrated for any losses, the gain and output power were calculated and produced below.

Results:

Frequency (MHz)	Signal Generator input level (dBm)	Input Cable Loss (dB)	Output Cable & Attenuator loss (dB)	Level at Spectrum Analyser (dBm)	Gain (dB)	Conducted Output Power (dBm)	Gain after 10dB input level increase (dB)
824.0	-54	0.13	30.29	-3.19	81.23	27.1	71.31
836.5	-52	0.25	30.42	-2.94	79.73	27.48	69.76
849.0	-53	0.23	30.43	-3.21	80.45	27.22	70.49

Notes:

1. The signal generator input was increased by 10dB and the level of the output signal was remeasured
2. In each case, a 5MHz wide filter was activated and a carrier was passed at the centre of each channel

Test equipment used:

Type Of Equipment	Maker/ Supplier	Model No	Serial No	TRaC Ref No	Actual Equipment Used
Spectrum Analyser	Rohde & Schwarz	FSU46	100021/046	UH281	X
Cable	TRaC	N/A	N/A	UH271	X
Cable	TRaC	N/A	N/A	UH272	X
Signal Generator	Rohde & Schwarz	Vector Signal Generator	255812	REF916	X

AMPLIFIER INTERMODULATION SPURIOUS EMISSIONS – CONDUCTED – UPLINK

Ambient temperature = 22°C
 Relative humidity = 42%
 Supply voltage = +110Vac

Radio Laboratory

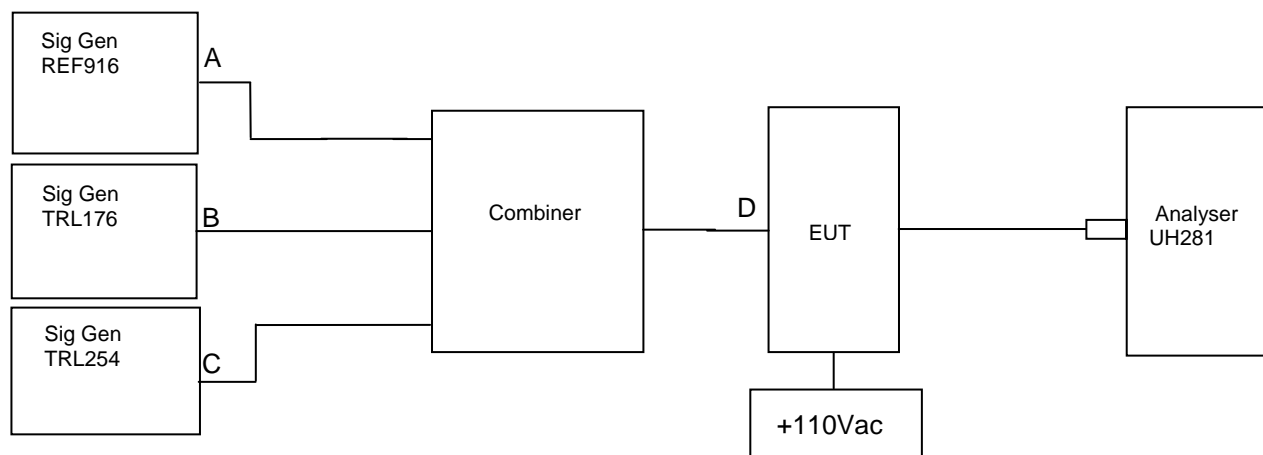

The intermodulation and spurious products were measured with the amplifier operating at maximum gain. A three tone test was conducted using the equipment as above. The input power level was adjusted so the level at point D was 10dB above the maximum input with 3 carriers. The cable and attenuator loss between the EUT and the spectrum analyser was 31dB.

Results:

RF Input Frequency (MHz)			Highest Intermodulation Product Level (dBm)	Limit (dBm)
824.0	836.5	849.0	No Significant emissions within 20dB	-13

Sweep data is shown on the next page.

Test equipment used:

Type Of Equipment	Maker/ Supplier	Model No	Serial No	TRaC Ref No	Actual Equipment Used
Spectrum Analyser	R&S	FSU46	100021/046	UH281	X
Signal Generator	Rohde & Schwarz	SMBV100a	255812	REF916	X
Signal Generator	Marconi	2042	119388/080	TRL176	X
Signal Generator	Marconi	2042	119562/021	TRL254	X

Intermodulation Close View

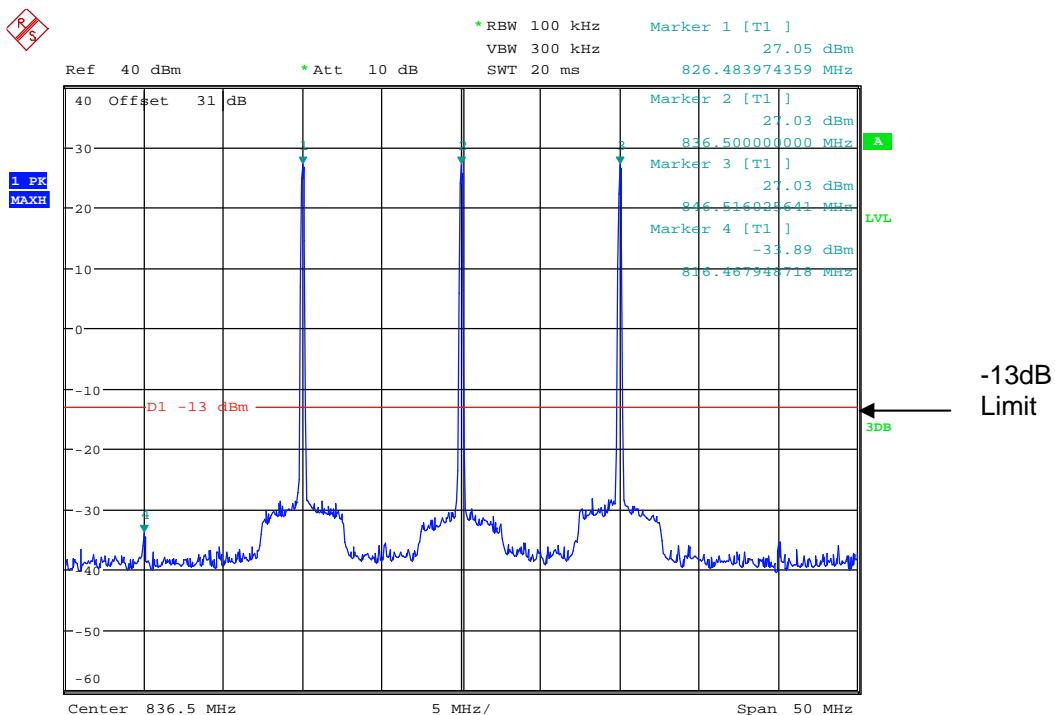

Date: 26.OCT.2011 14:15:40

Intermodulation Wide View

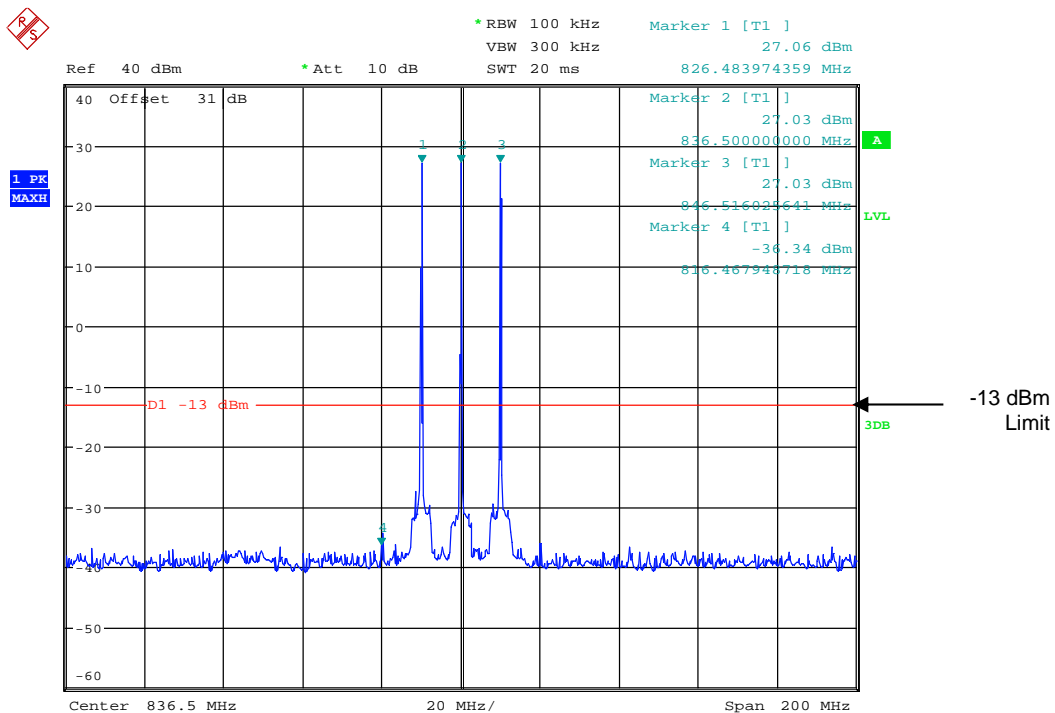

Date: 26.OCT.2011 14:16:03

The above plots show that there are no products within 20 dB of the spurious limit.

Intermodulations Scan 9kHz–150 kHz

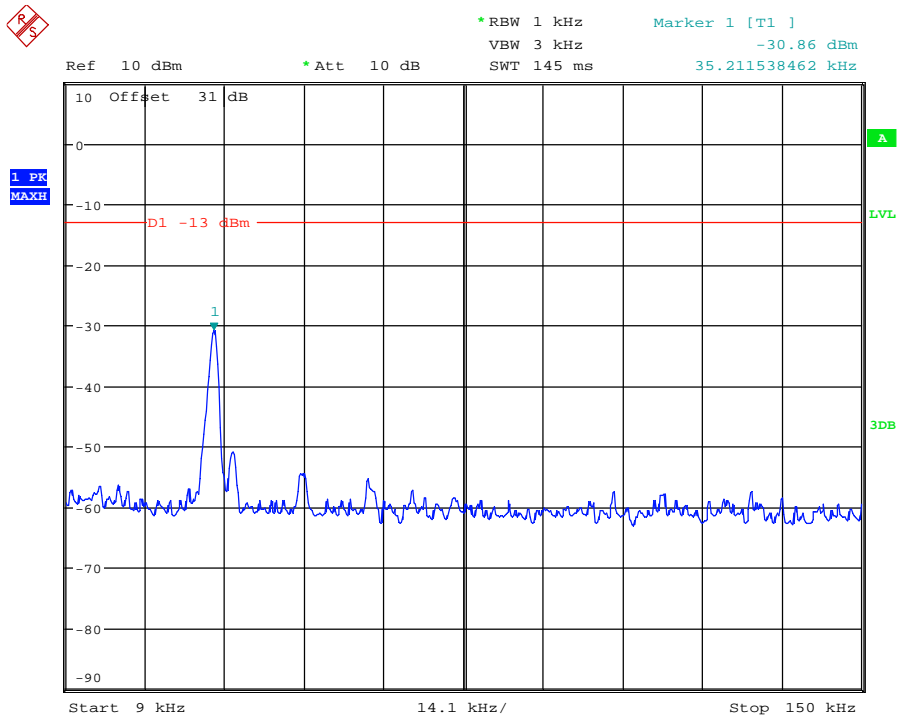

Date: 26.OCT.2011 14:17:30

Intermodulations Scan 150kHz–30MHz

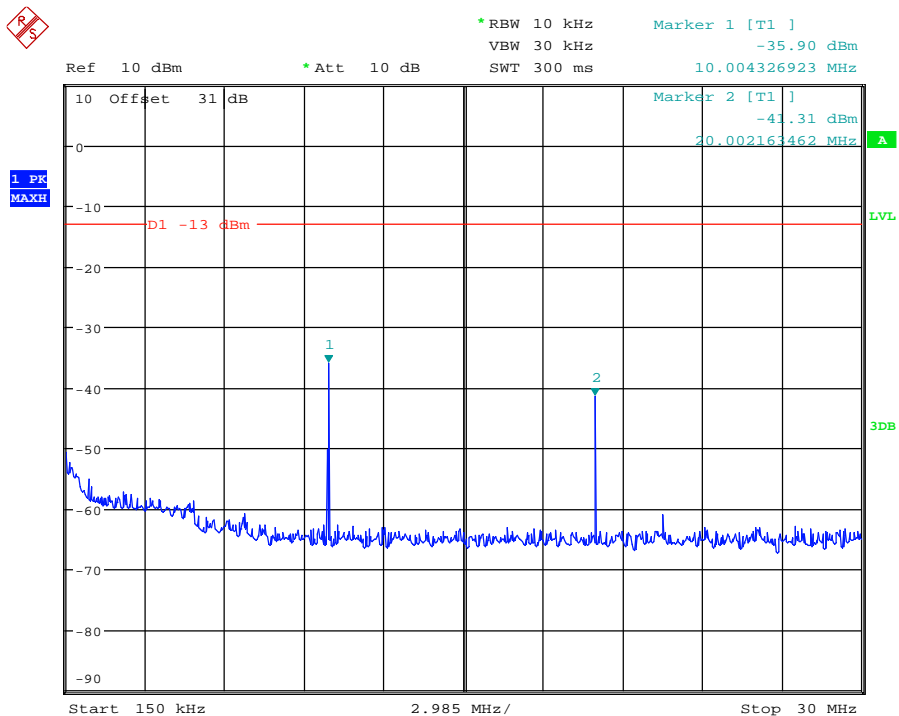

Date: 26.OCT.2011 14:18:33

Intermodulations Scan 30MHz-1GHz

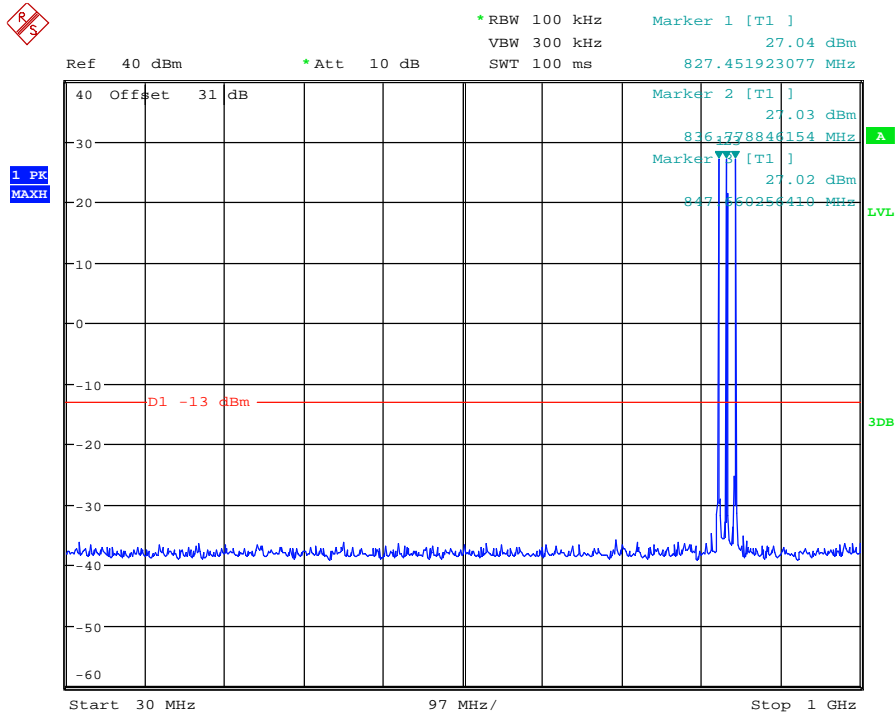

Date: 26.OCT.2011 14:19:23

Intermodulations Scan 1GHz-5GHz

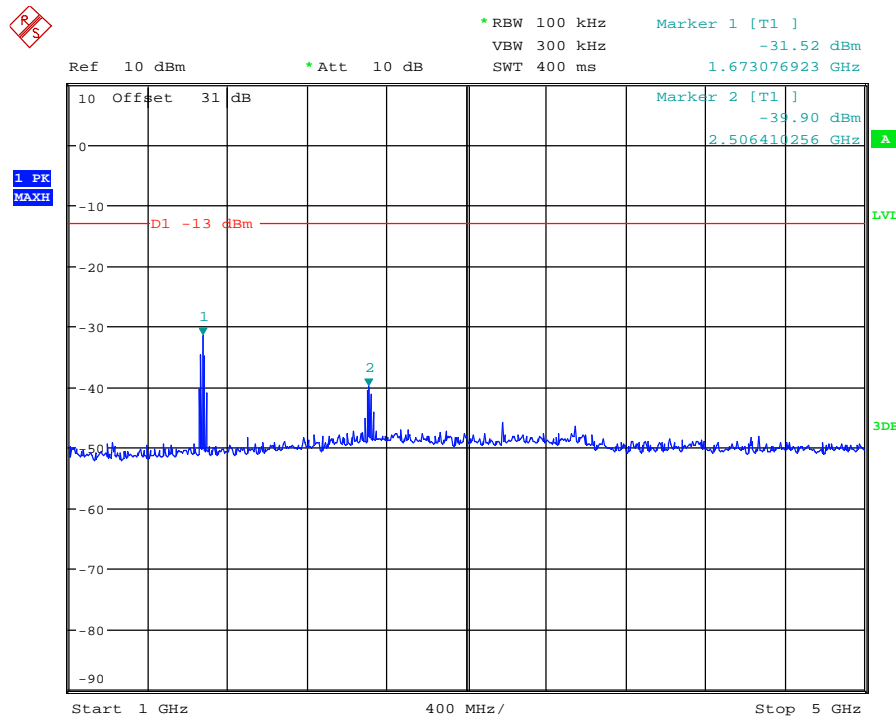

Date: 26.OCT.2011 14:21:08

Intermodulations Scan 5GHz-9GHz

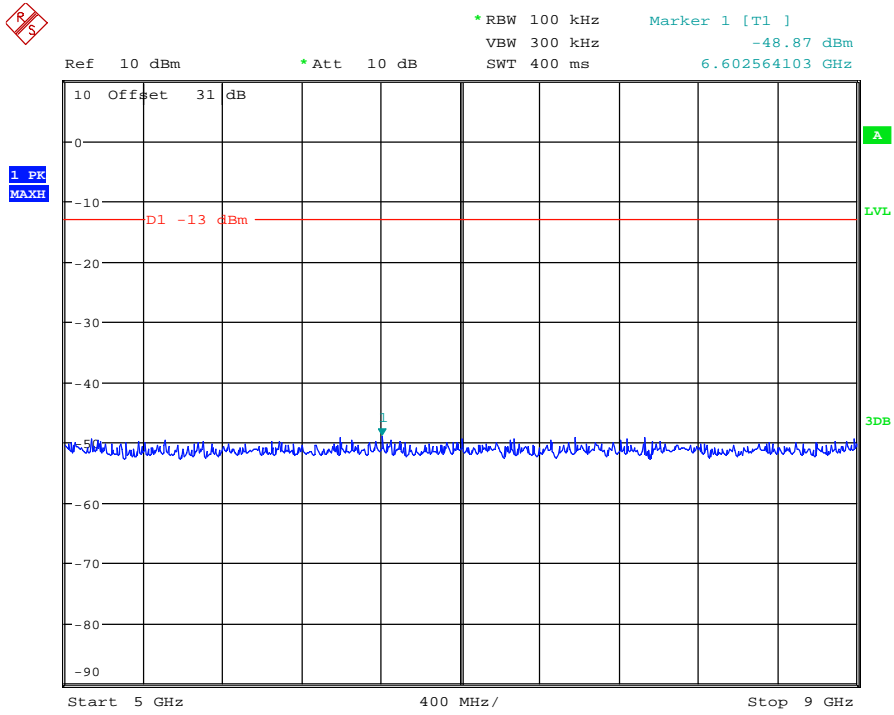

Date: 26.OCT.2011 14:21:44

AMPLIFIER MODULATED CHANNEL TEST – CONDUCTED – UPLINK

Ambient temperature = 22°C
 Relative humidity = 42%
 Supply voltage = +110Vac
 Channel number = See test results

Radio Laboratory

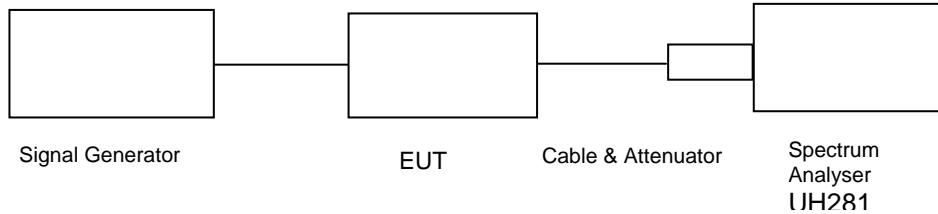

This test was performed to show that the amplifier does not alter the input signal in any way. The input signal was set beyond compression point and modulated with different schemes given below. The plots show the signal measured at the signal generator (black) and the signal measured at the output of the EUT (blue).

Note: The cables and attenuators had the following losses.

1. Cable and attenuator losses between EUT and spectrum analyser were about 30.5dB
2. Cable loss between signal generator and EUT was about 0.5dB
3. See Table below for 99% Power Occupied Bandwidth

Results:

Frequency Of Operational Channel	Occupied Bandwidth for each modulation type (kHz)		
	GSM	CDMA	W-CDMA
Bottom	245.192	1266.025	4174.679
Middle	246.794	1262.820	4174.679
Top	248.397	1259.615	4174.679

Note: For each type of signal, the most appropriate filter bandwidth was used which was just wide enough to pass the signal

Test Equipment Used:

Type Of Equipment	Maker/ Supplier	Model No	Serial No	TRaC Ref No	Actual Equipment Used
Spectrum Analyser	R&S	FSU46	100021/046	UH281	X
Signal Generator	Agilent	E4438C	N/A	N/A	X

824.0 MHz Signal Generator and EUT deviation set to CDMA

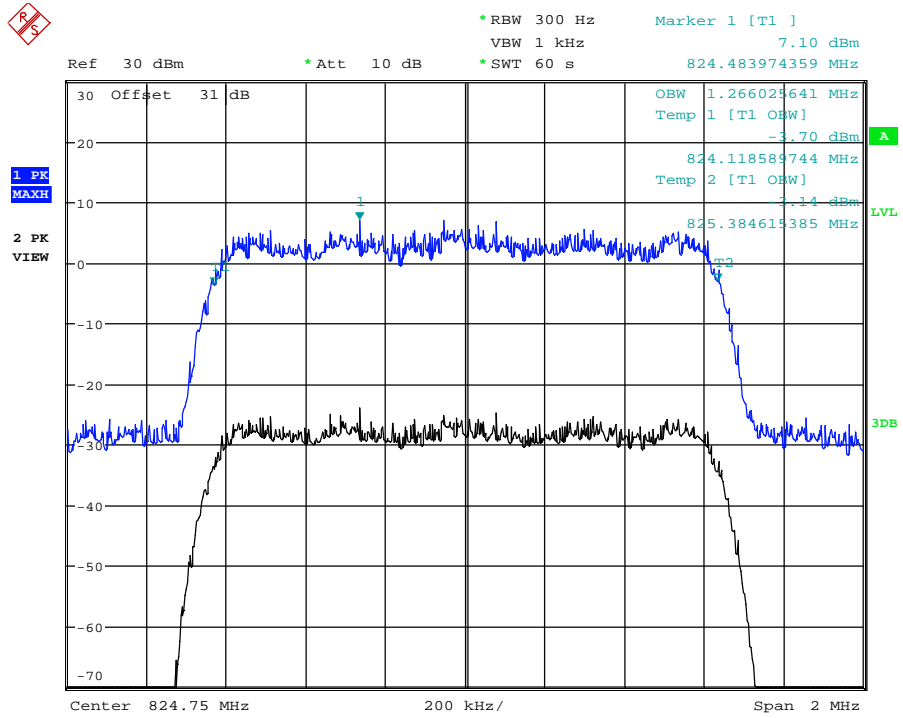

Date: 31.OCT.2011 12:23:49

836.5 MHz Signal Generator and EUT deviation set to CDMA

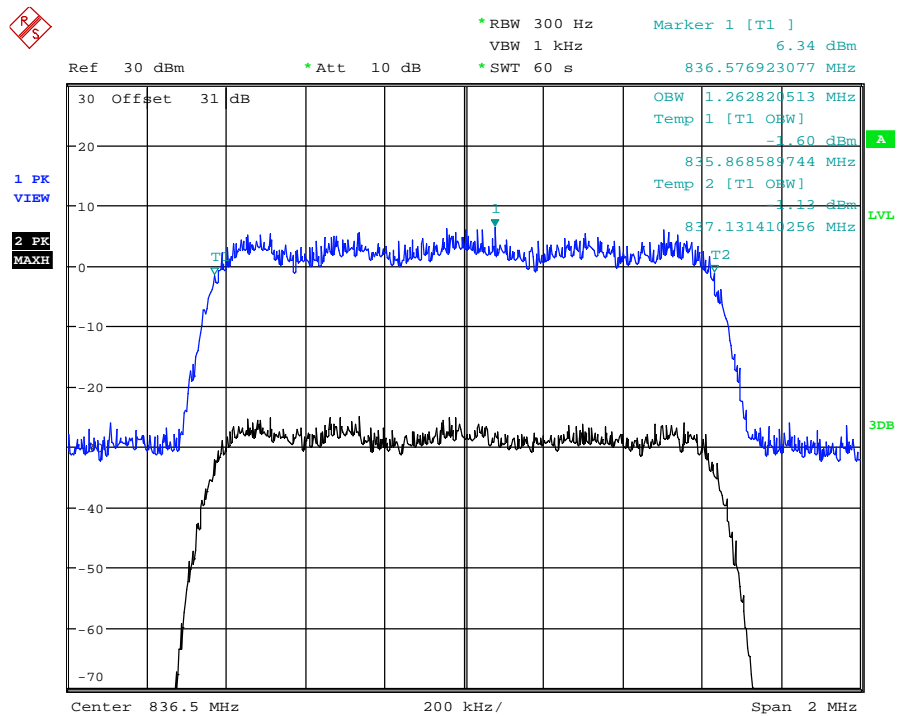

Date: 31.OCT.2011 12:29:02

849.0 MHz Signal Generator and EUT deviation set to CDMA

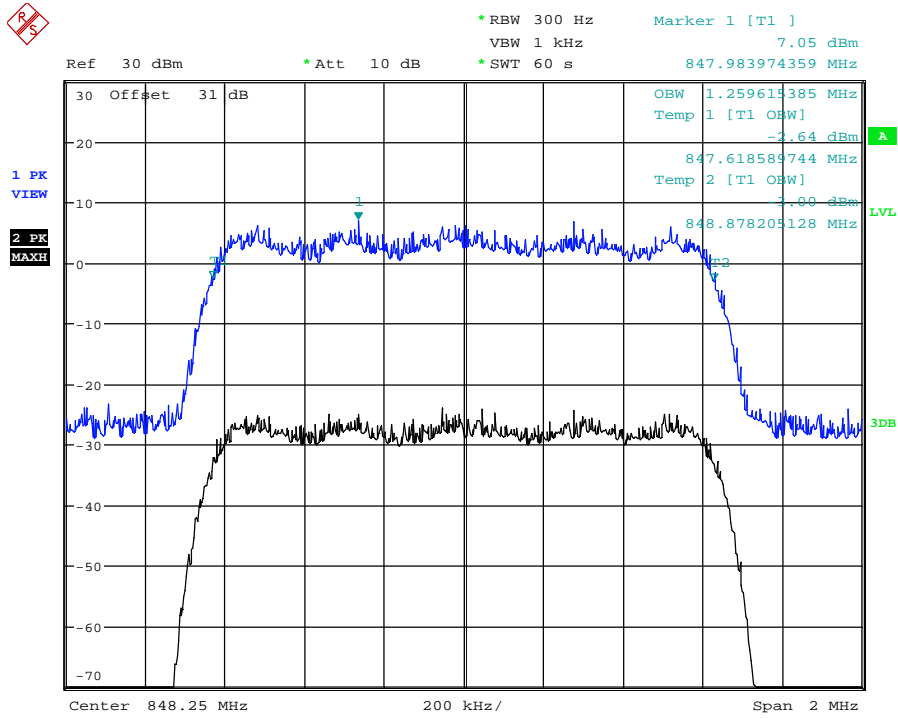

Date: 31.OCT.2011 12:37:09

824.0 MHz Signal Generator and EUT deviation set to W-CDMA

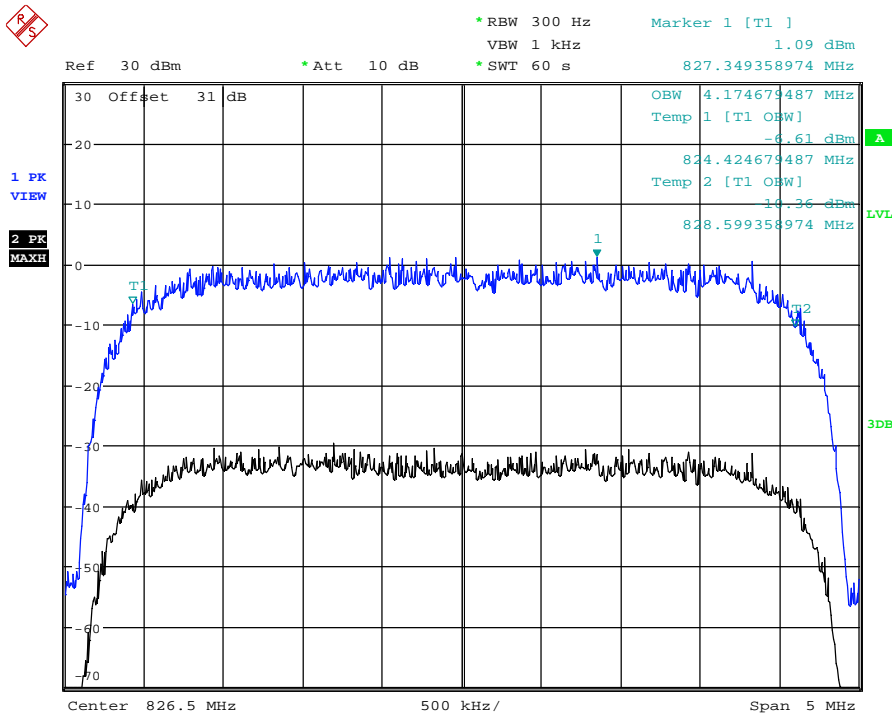

Date: 31.OCT.2011 10:58:18

836.5 MHz Signal Generator and EUT deviation set to W-CDMA

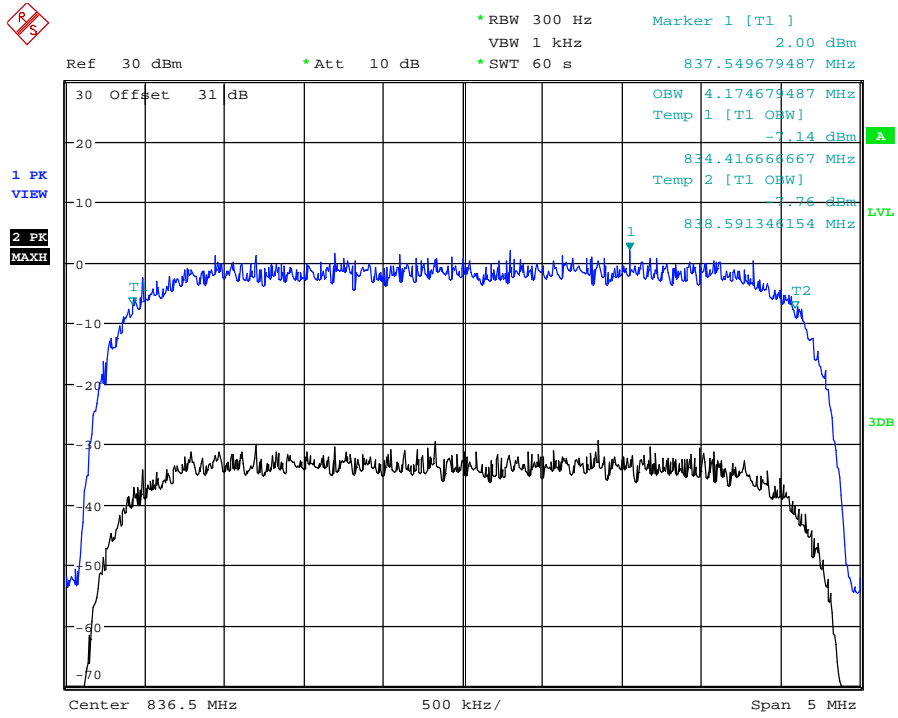

Date: 31.OCT.2011 10:54:46

849.0 MHz Signal Generator and EUT deviation set to W-CDMA

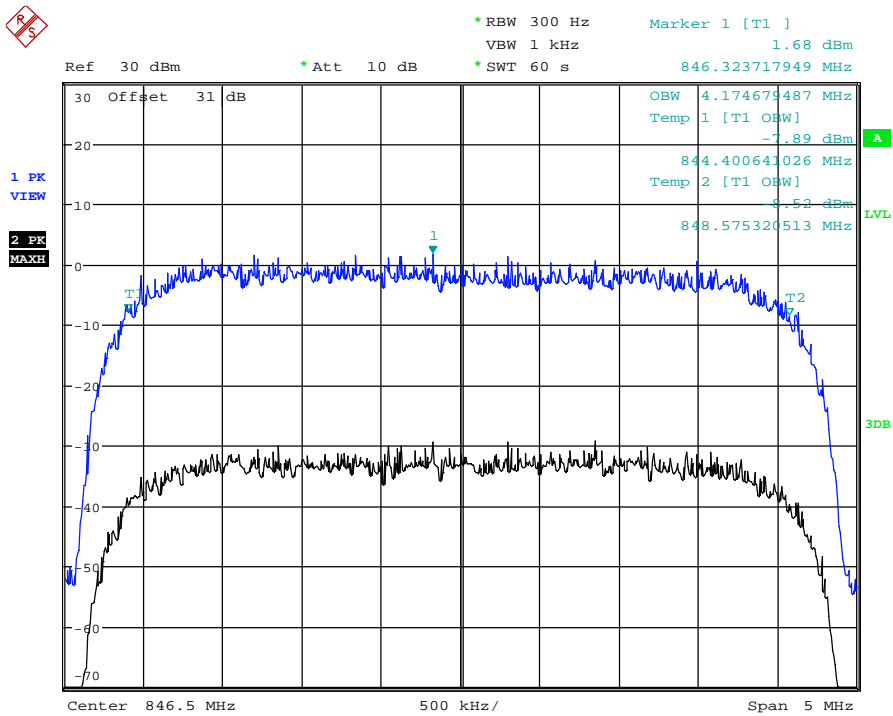

Date: 31.OCT.2011 10:41:33

824.0 MHz Signal Generator and EUT deviation set to GSM

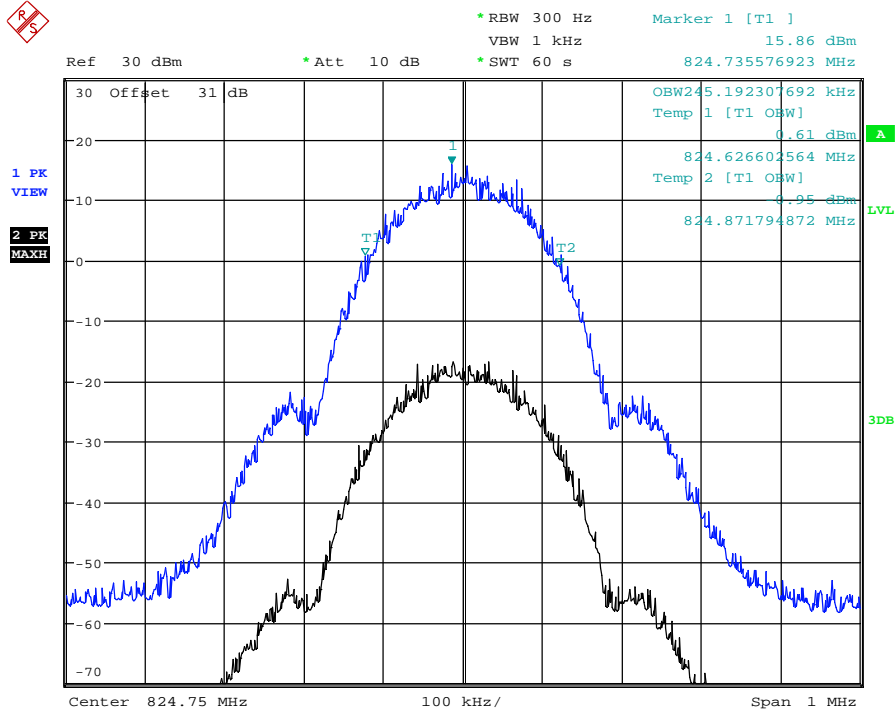

Date: 31.OCT.2011 12:47:45

836.5 MHz Signal Generator and EUT deviation set to GSM

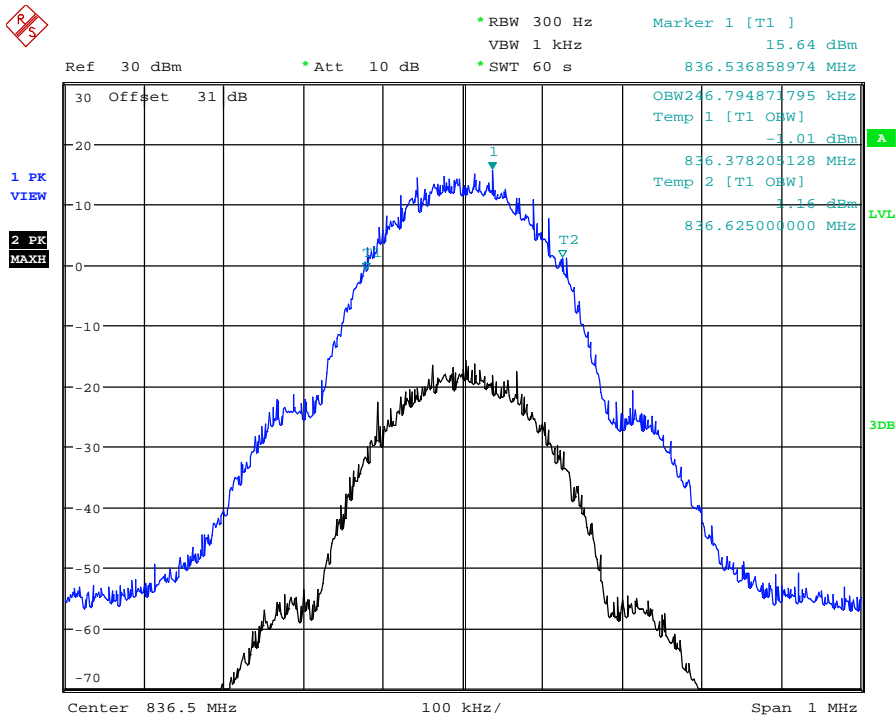

Date: 31.OCT.2011 12:44:19

849.0 MHz Signal Generator and EUT deviation set to GSM

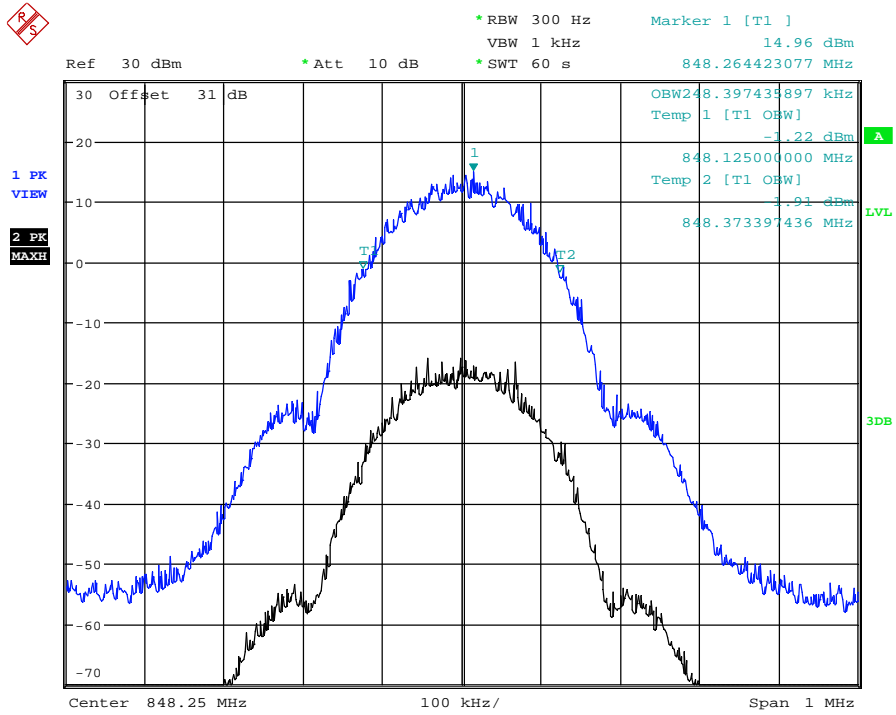

Date: 31.OCT.2011 12:40:23

The above plots depicting the output waveshape show no measurable distortion visible when compared to the input signal.

AMPLIFIER SPURIOUS EMISSIONS – CONDUCTED – UPLINK

Ambient temperature = 22°C
 Relative humidity = 42%
 Supply voltage = +110Vac
 Radio Laboratory
 Test Signal = CW

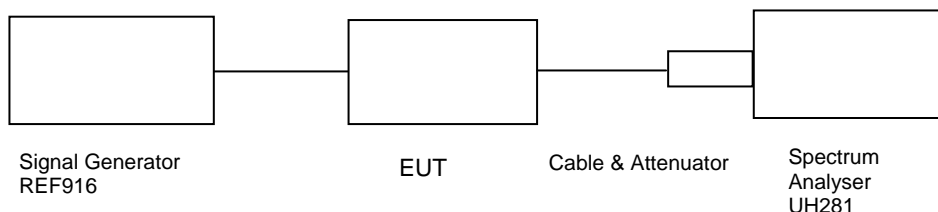

The test was set up as per the diagram. The level at the input was adjusted to compensate for the loss of the interconnecting cable. The unit was tested operating at maximum power and on three test frequencies.

The Spurious limit was calculated as follows:

On any frequency removed from the assigned frequency by more that 250% of the authorised bandwidth

At least $43 + 10 \log P$ dB

$(10 \log P_{\text{watts}}) - (43 + 10 \log (P_{\text{watts}} / 1000)) = \text{LIMIT} = -13 \text{ dBm}$

Results:

FREQUENCY RANGE	FREQ. (MHz)	MEASURED LEVEL (dBm)	ATTENUATOR & CABLE LOSSES (dB)	EMISSION LEVEL (dBm)	LIMIT (dBm)
9kHz – 9GHz	No Significant Emissions Within 20dB of Limit				-13

Test equipment used:

Type Of Equipment	Maker/ Supplier	Model No	Serial No	TRaC Ref No	Actual Equipment Used
Spectrum Analyser	Rohde & Schwarz	FSU46	100021/046	UH281	X
Cable	TRaC	N/A	N/A	UH271	X
Cable	TRaC	N/A	N/A	UH272	X
Signal Generator	Rohde & Schwarz	Vector Signal Generator	255812	REF916	X

824.0MHz 9kHz-150kHz

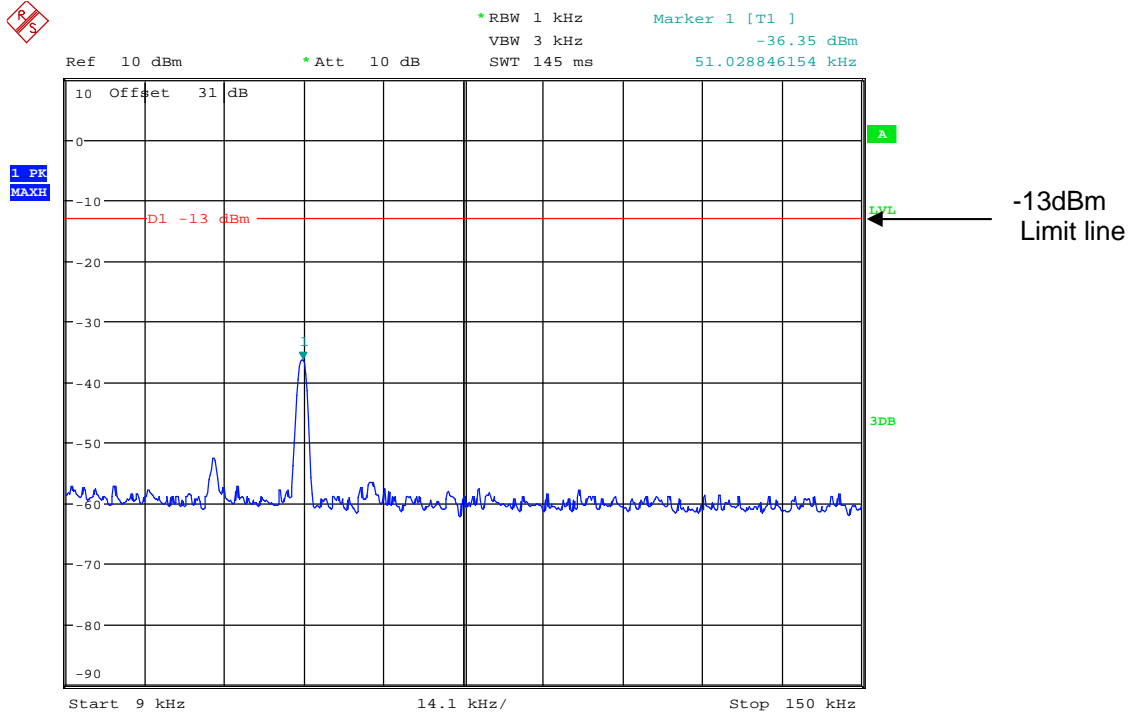

Date: 24.OCT.2011 10:15:05

824.0MHz 150kHz-30MHz

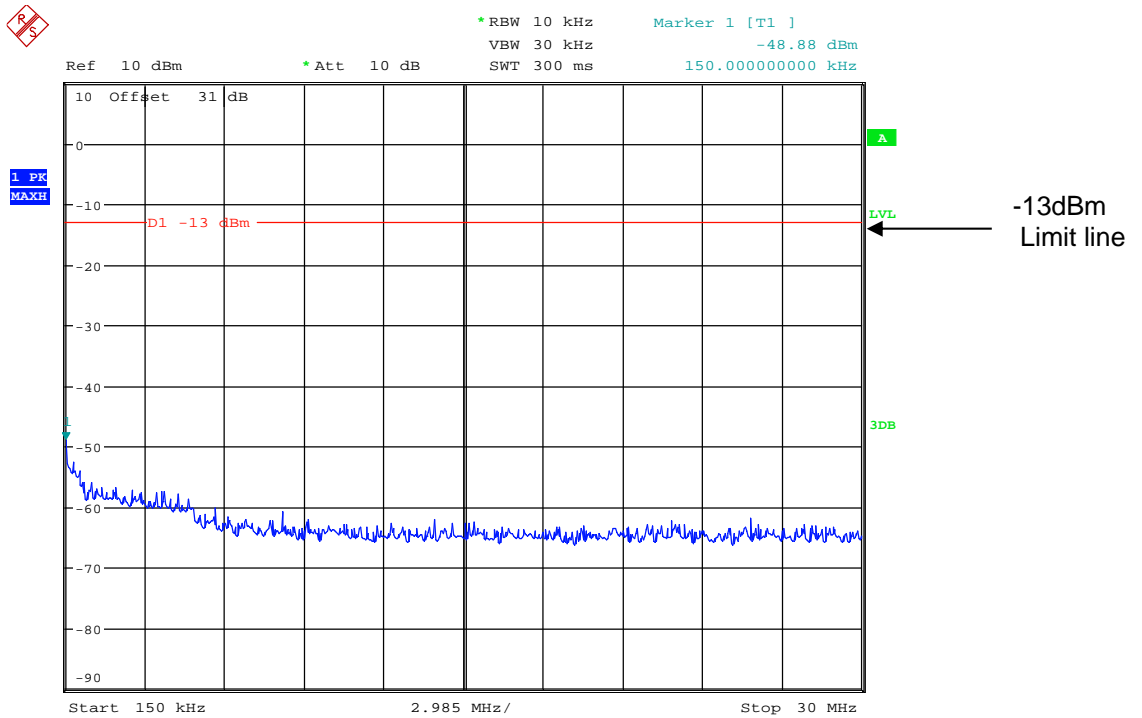

Date: 24.OCT.2011 10:08:06

824.0MHz 30MHz-1GHz

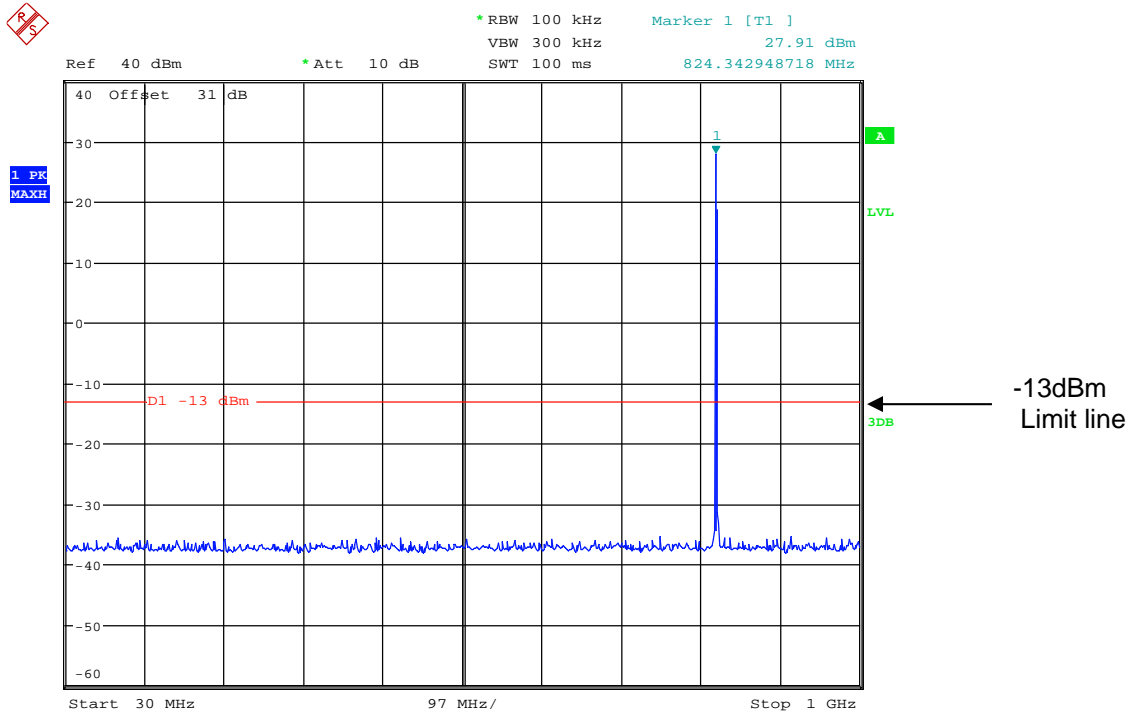

Date: 24.OCT.2011 10:10:12

824.0MHz 1GHz-5GHz

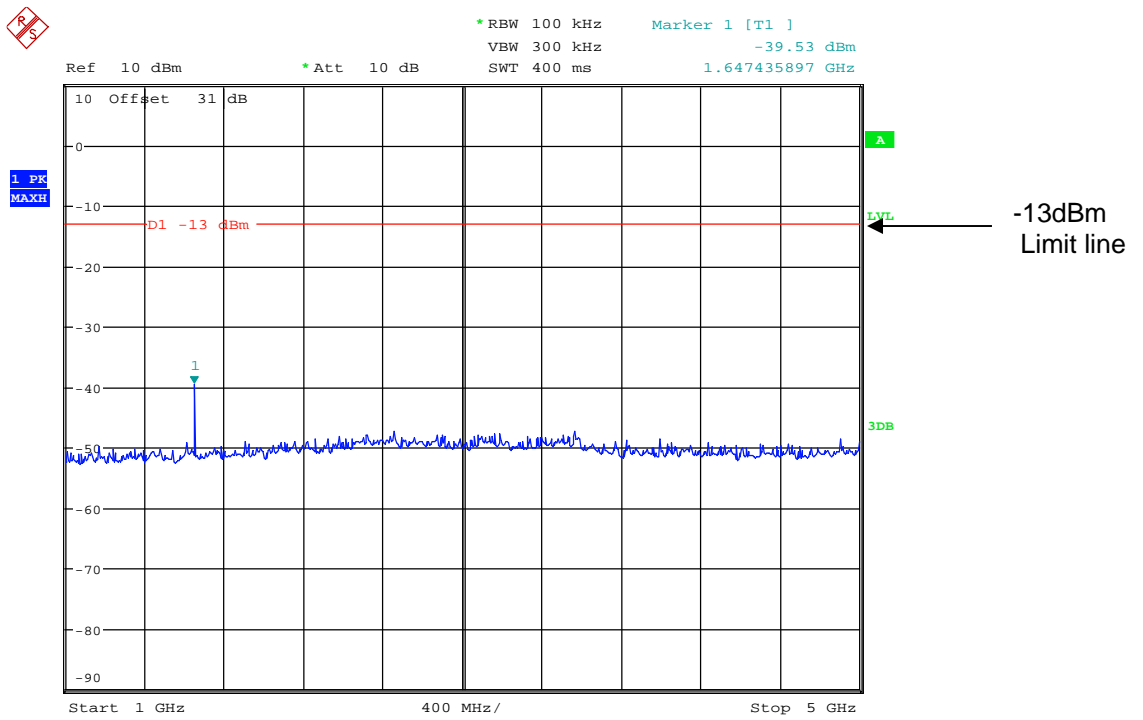

Date: 24.OCT.2011 10:11:29

824.0MHz 5GHz-9GHz

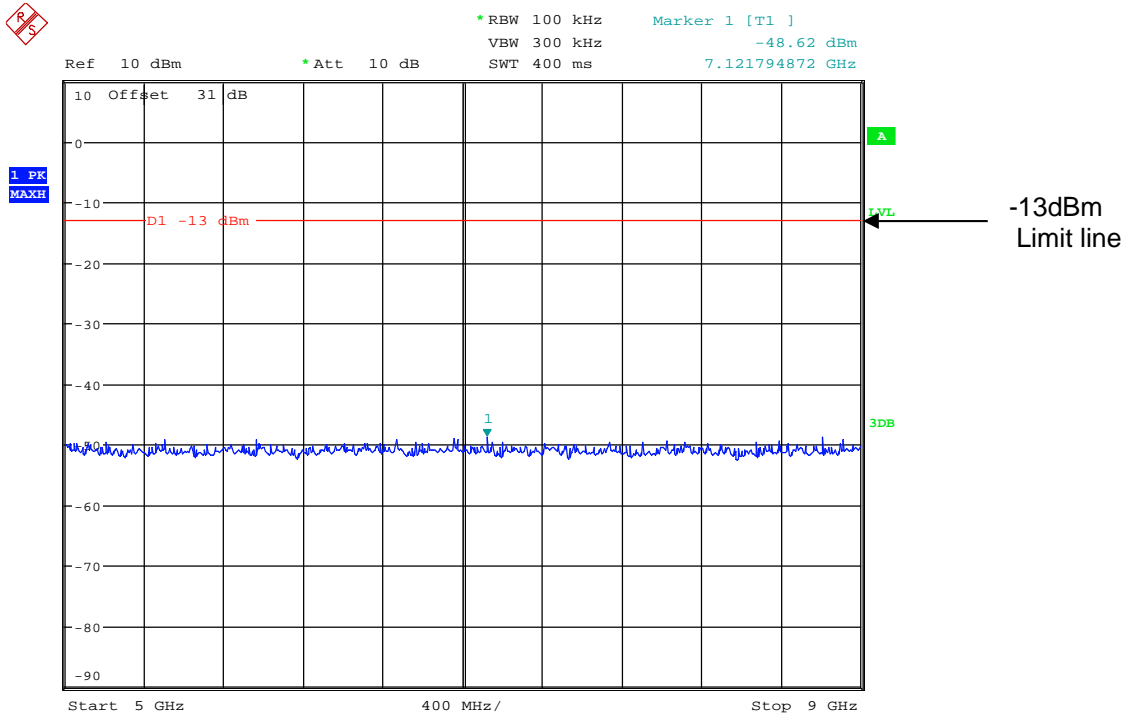

Date: 24.OCT.2011 10:13:12

836.5MHz 9kHz-150kHz

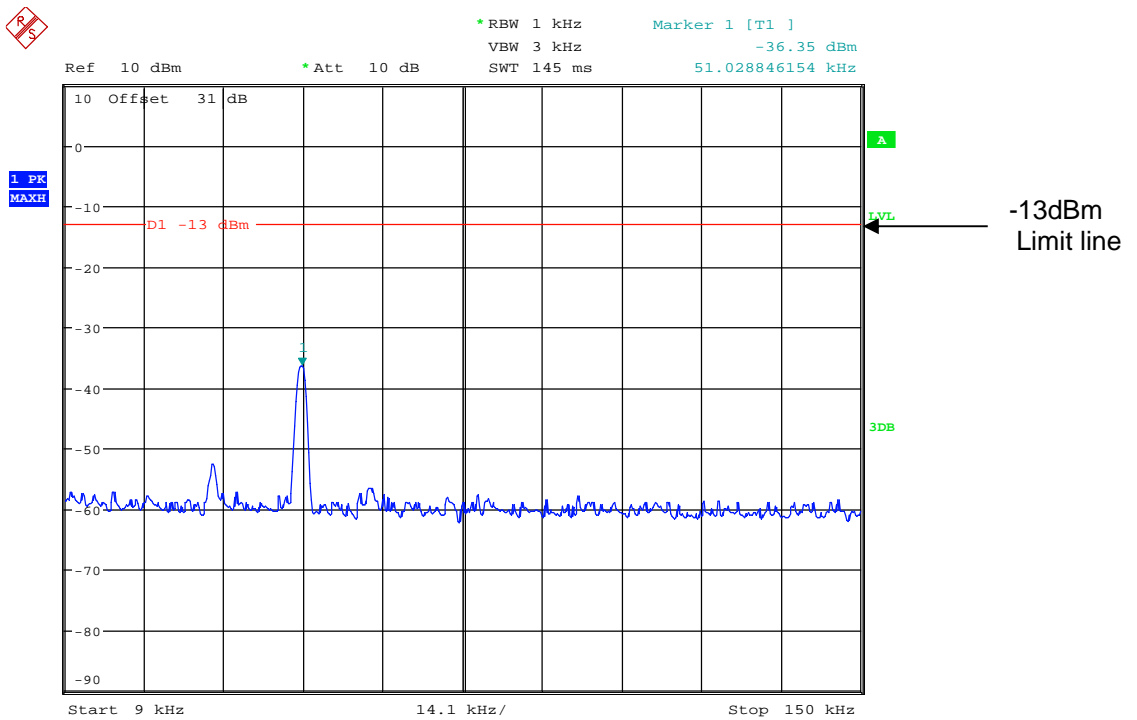

Date: 24.OCT.2011 10:15:05

836.5MHz 150kHz-30MHz

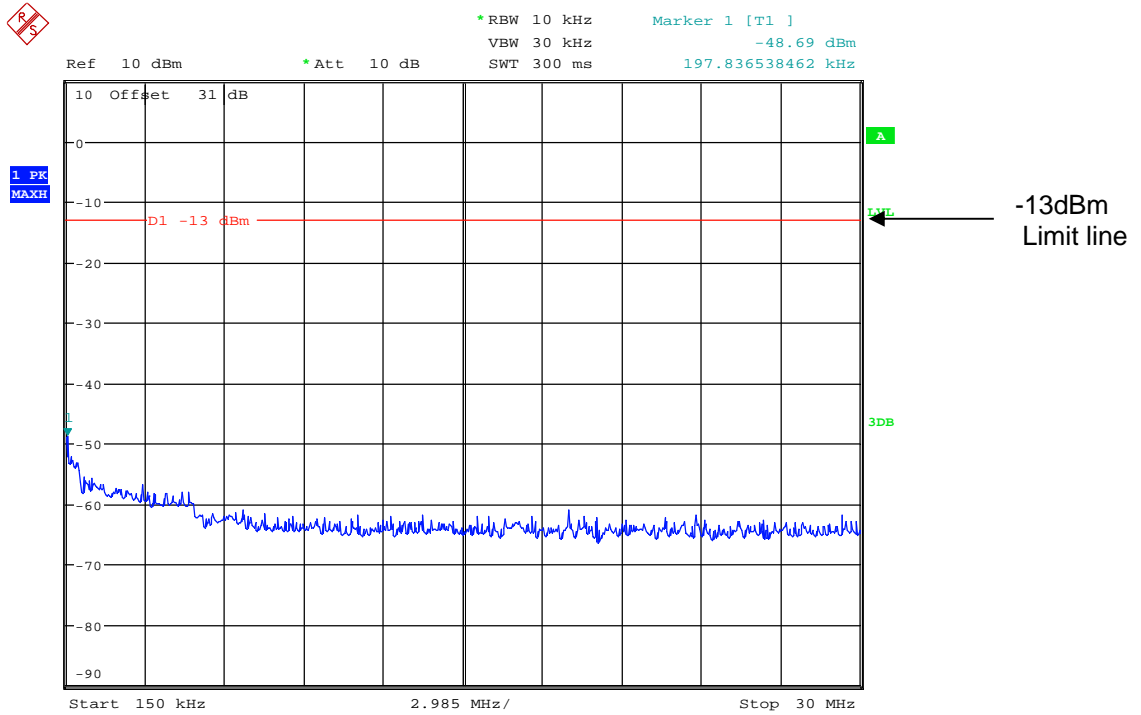

Date: 24.OCT.2011 10:15:47

836.5MHz 30MHz-1GHz

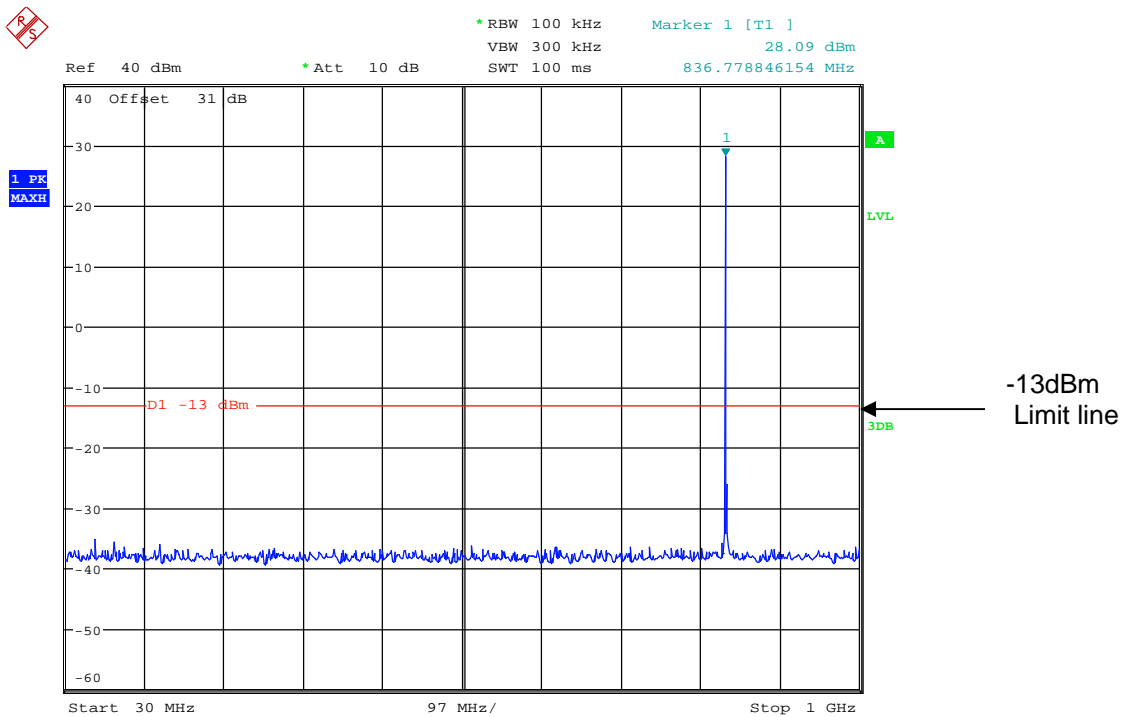

Date: 24.OCT.2011 10:16:24

836.5MHz 1GHz-5GHz

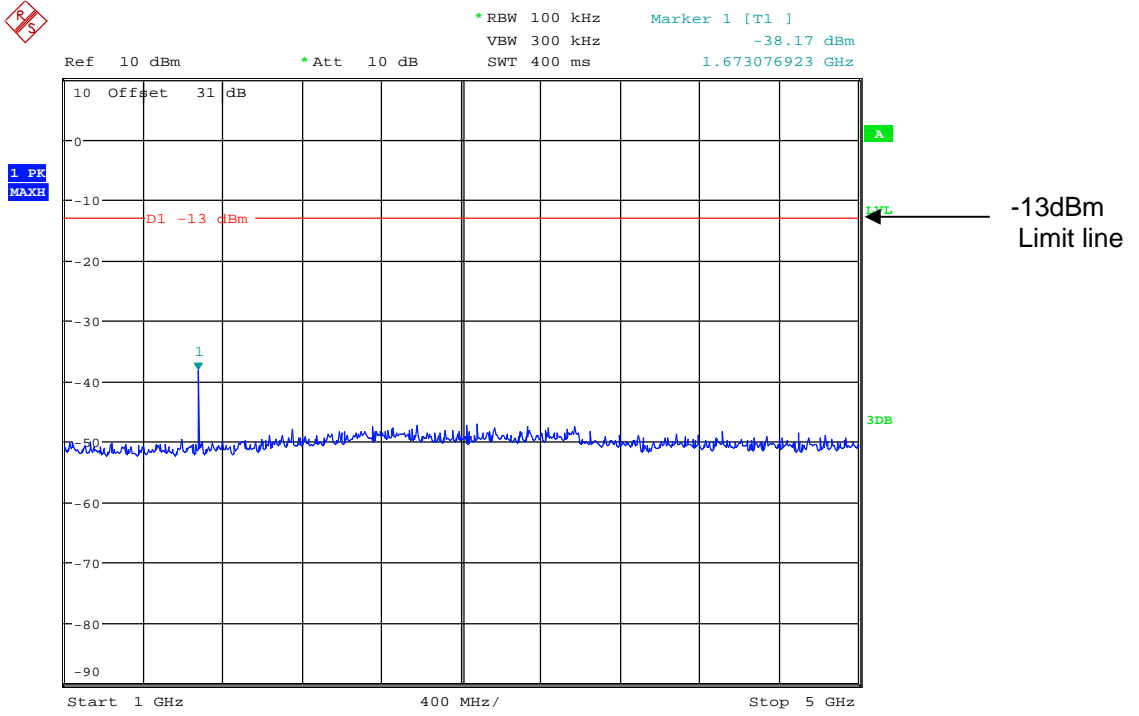

Date: 24.OCT.2011 10:23:25

836.5MHz 5GHz-9GHz

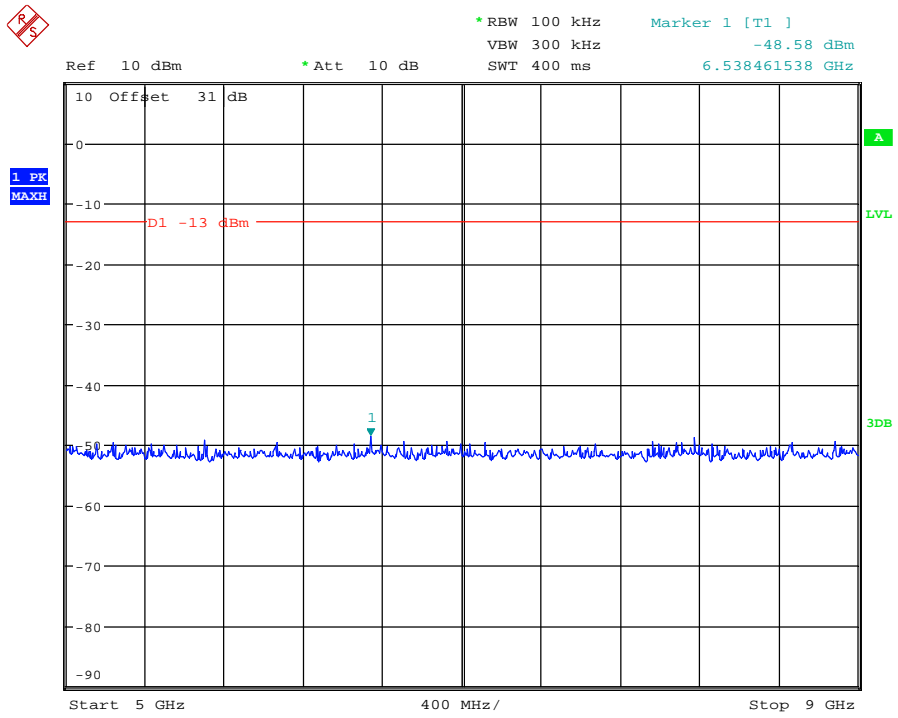

Date: 24.OCT.2011 10:23:44

849.0MHz 9kHz-150kHz

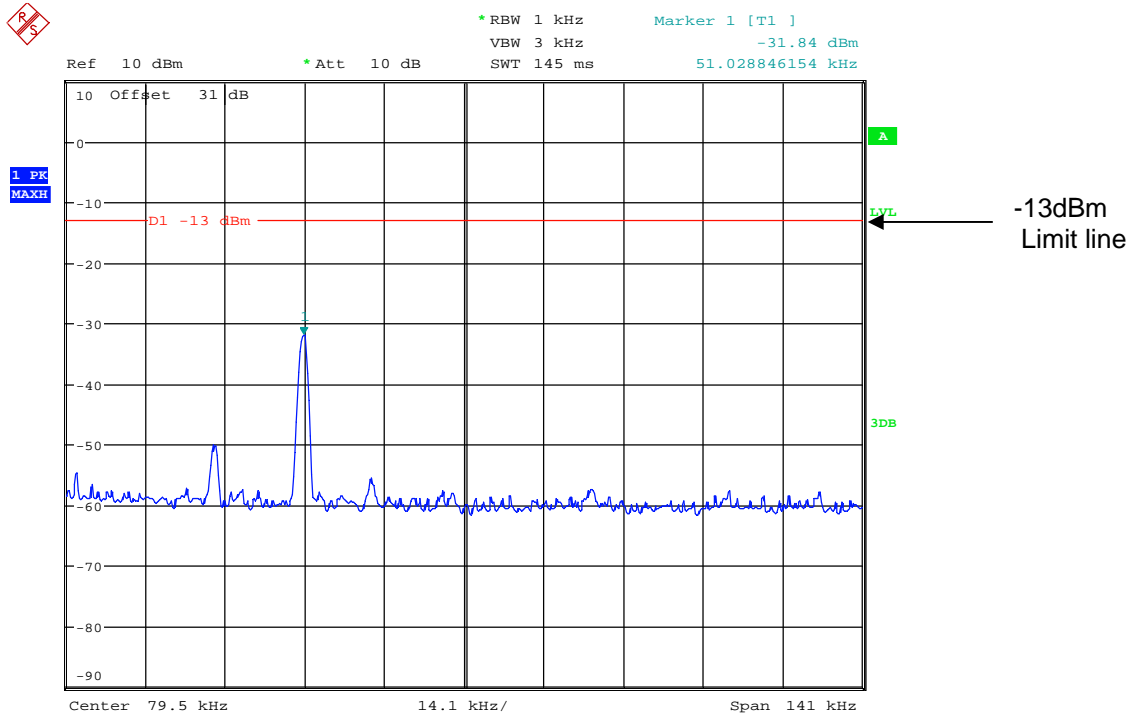

Date: 24.OCT.2011 10:20:05

849.0MHz 150kHz-30MHz

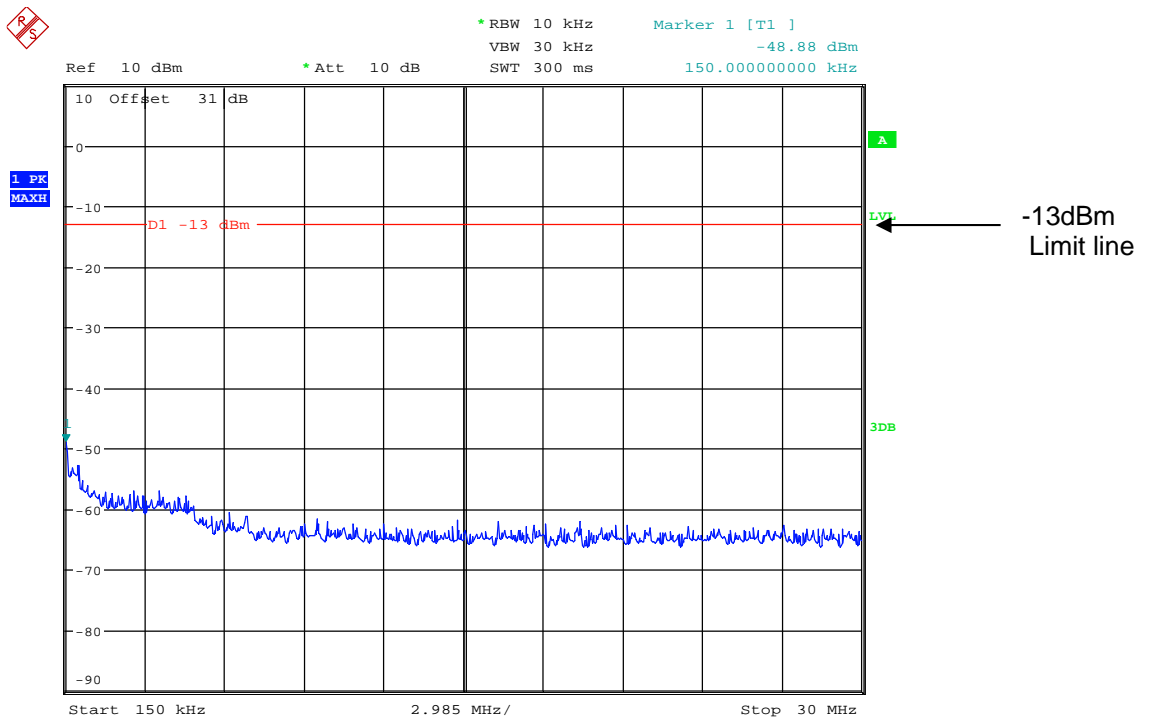

Date: 24.OCT.2011 10:20:45

849.0MHz 30MHz-1GHz

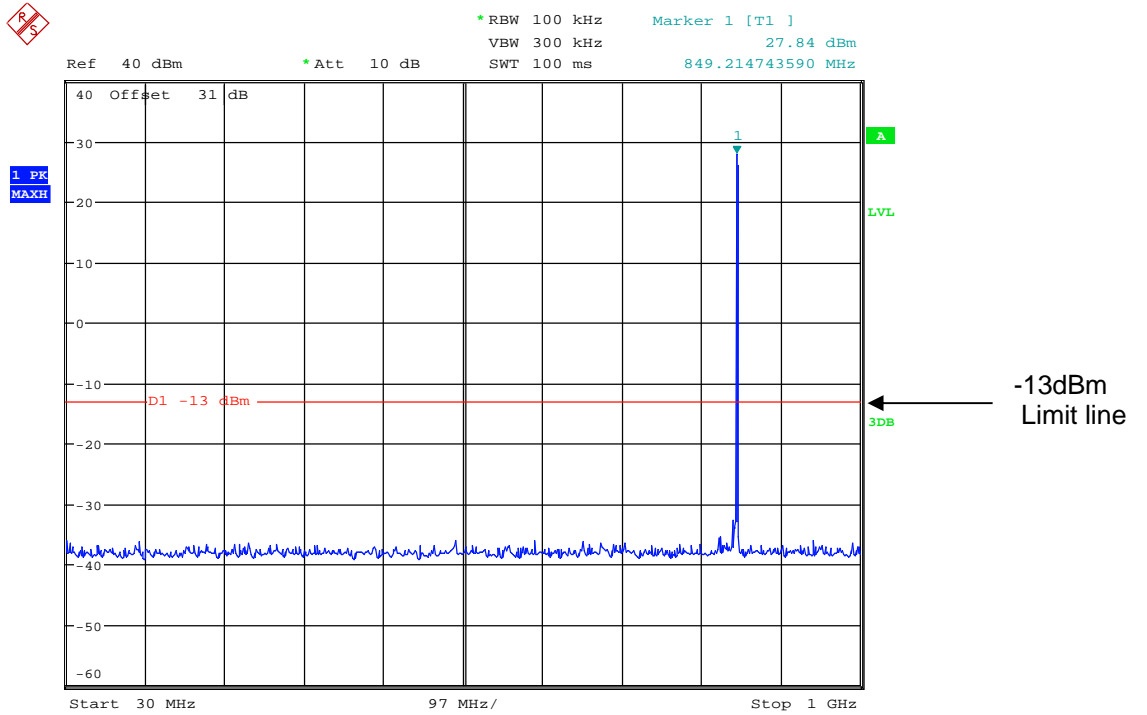

Date: 24.OCT.2011 10:21:17

849.0MHz 1GHz-5GHz

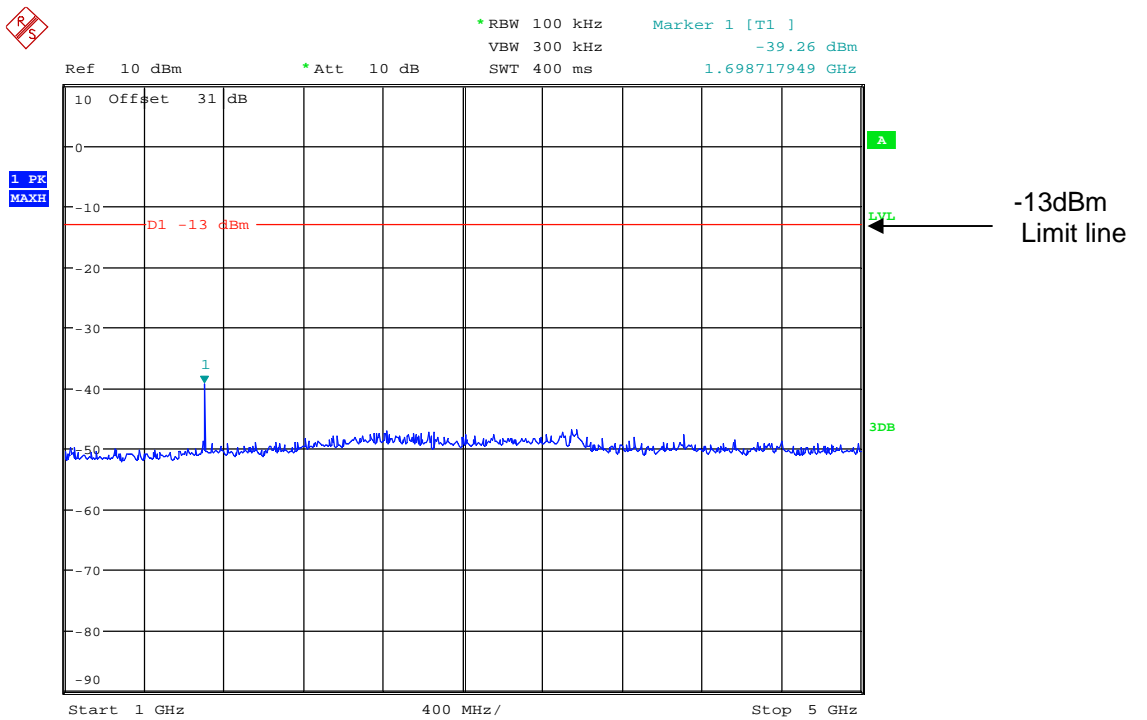

Date: 24.OCT.2011 10:22:16

849.0MHz 5GHz-9GHz

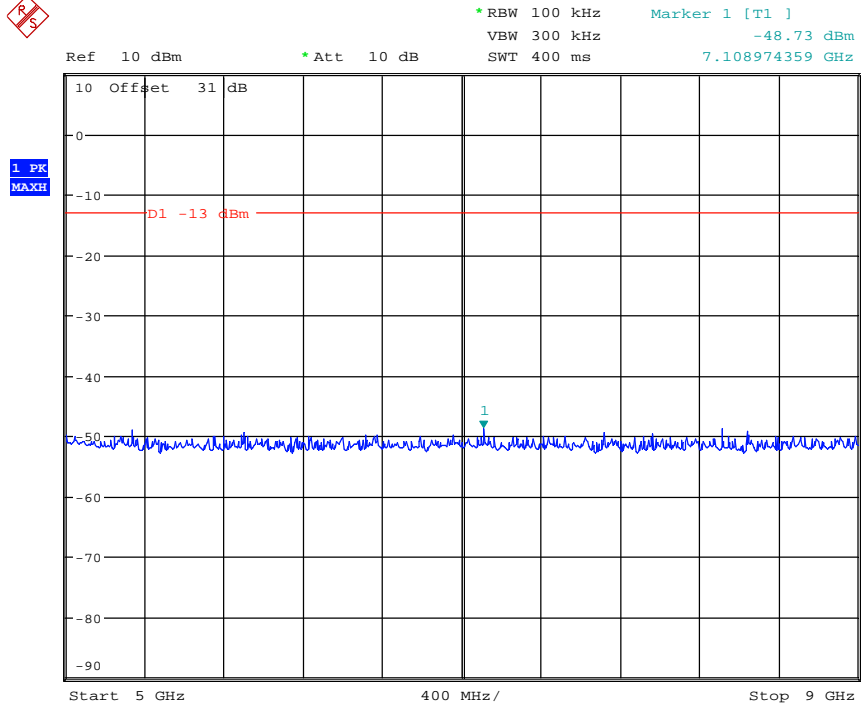

Date: 24.OCT.2011 10:22:37

AMPLIFIER SPURIOUS EMISSIONS – RADIATED – UPLINK

Ambient temperature = 22°C
 Relative humidity = 46%
 Conditions = ALSR
 Supply voltage = +110Vac
 Supply Frequency = N/A

Test Signal = CW

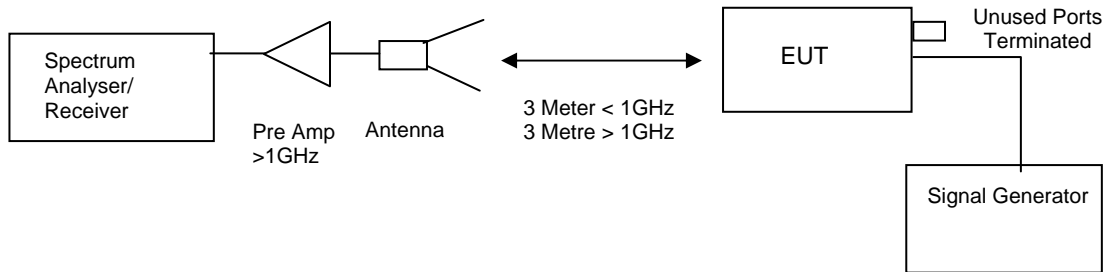

The test was set up as per the diagram. The level at the input was adjusted to compensate for the loss of the interconnecting cable. The unit was tested operating maximum power on three test frequencies with a 50 ohm load on the output. The unit was also tested with the signal generator replaced by another 50ohm load.

The Spurious limit was calculated as follows:

On any frequency removed from the assigned frequency by more that 250% of the authorised bandwidth

At least $43 + 10 \log P$ dB

$$(10\log P_{\text{watts}}) - (43 + 10\log (P_{\text{watts}} / 1000)) = \text{LIMIT} = -13 \text{ dBm}$$

Results:

FREQUENCY RANGE	FREQ. (MHz)	MEAS. Rx. (dBµV)	CABLE LOSS (dB)	ANT FACTOR	FIELD STRENGTH (dBµV/m)	CALCULATED EIRP (dBm)	LIMIT (dBm)
30MHz – 9GHz	No Significant Emissions Within 20dB of Limit.						-13

Test equipment used:

Type Of Equipment	Maker/ Supplier	Model No	Serial No	TRaC Ref No	Actual Equipment Used
Horn	Emco	3115	9010-3580	138	X
Spectrum Analyser	R&S	FSU46	100021/046	UH281	X
Pre Amplifier	HP	8449B	3008A016	572	X
Signal Generator	Marconi	2042	119388/080	176	X
Antenna	York	CBL611/A	1618	UH191	X
Receiver	R&S	ESVS10	825892/006	UH04	X

824.0MHz 30MHz-1GHz

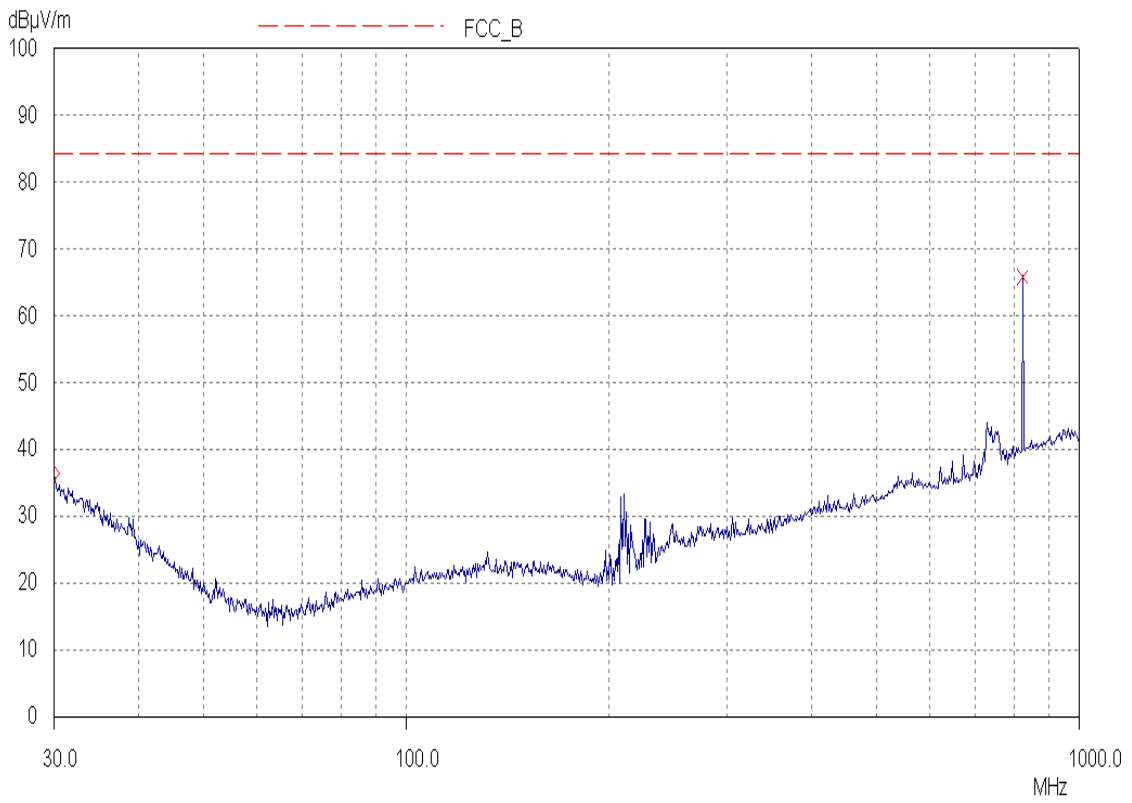

824.0MHz 1GHz-9GHz

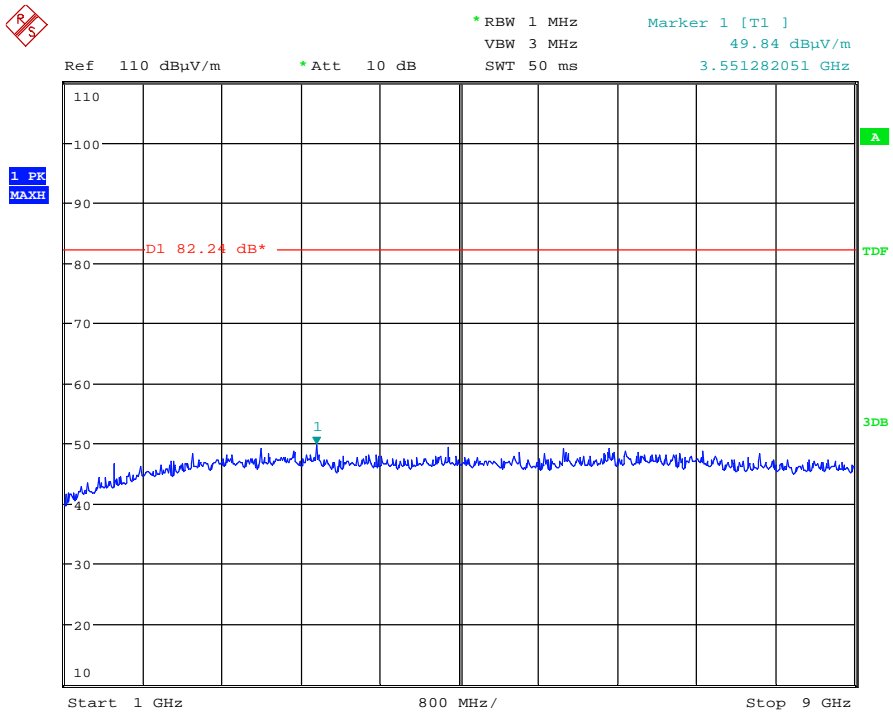

Date: 25.OCT.2011 15:04:08

836.5MHz 30MHz-1GHz

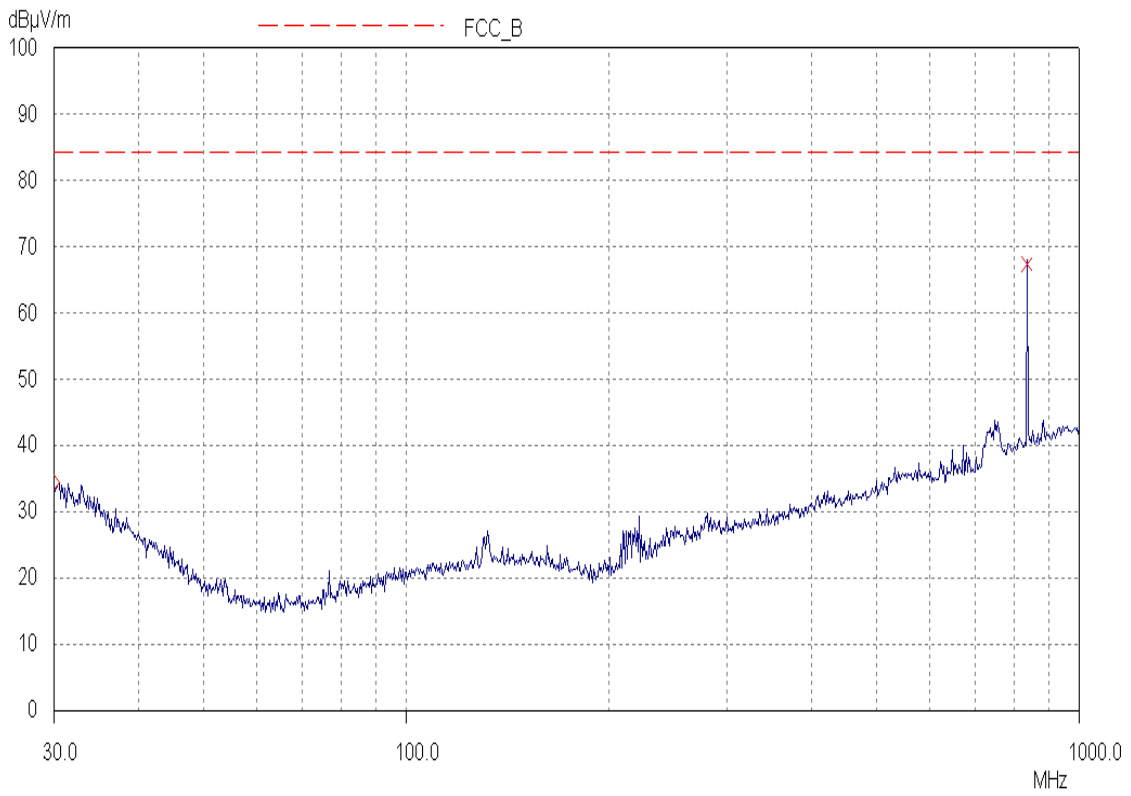

836.5MHz 1GHz-9GHz

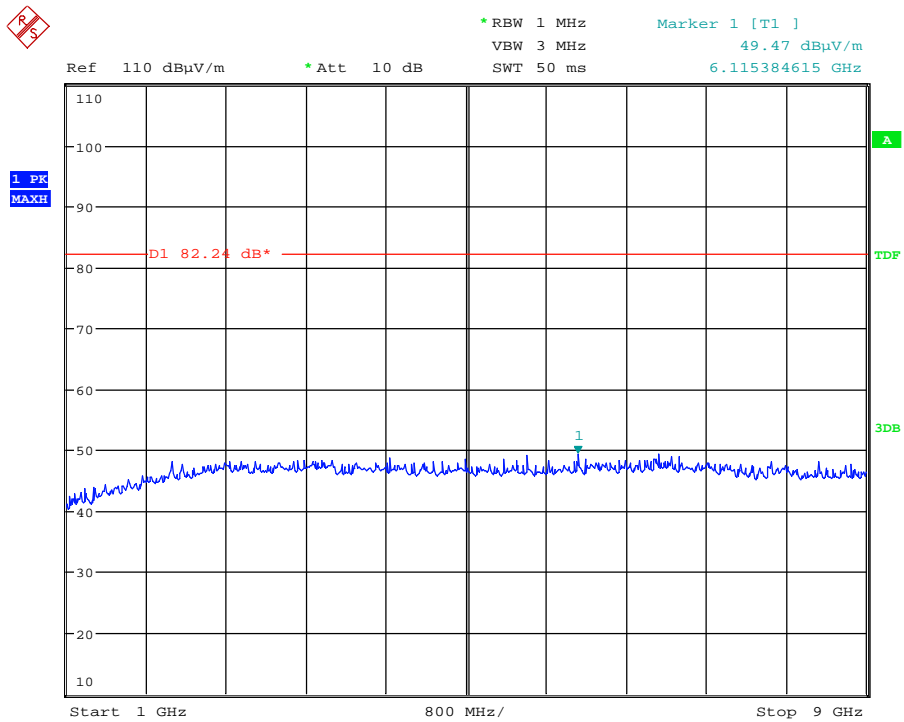

Date: 25.OCT.2011 15:05:04

849.0MHz 30MHz-1GHz

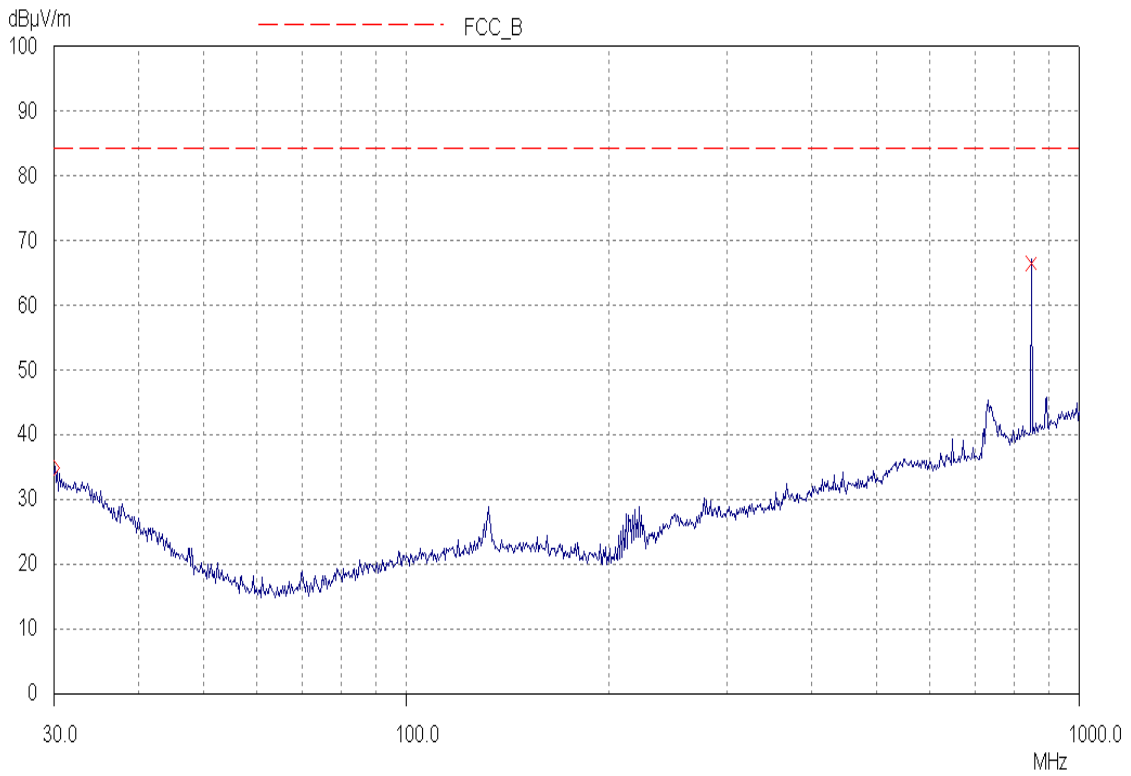

849.0MHz 1GHz-9GHz

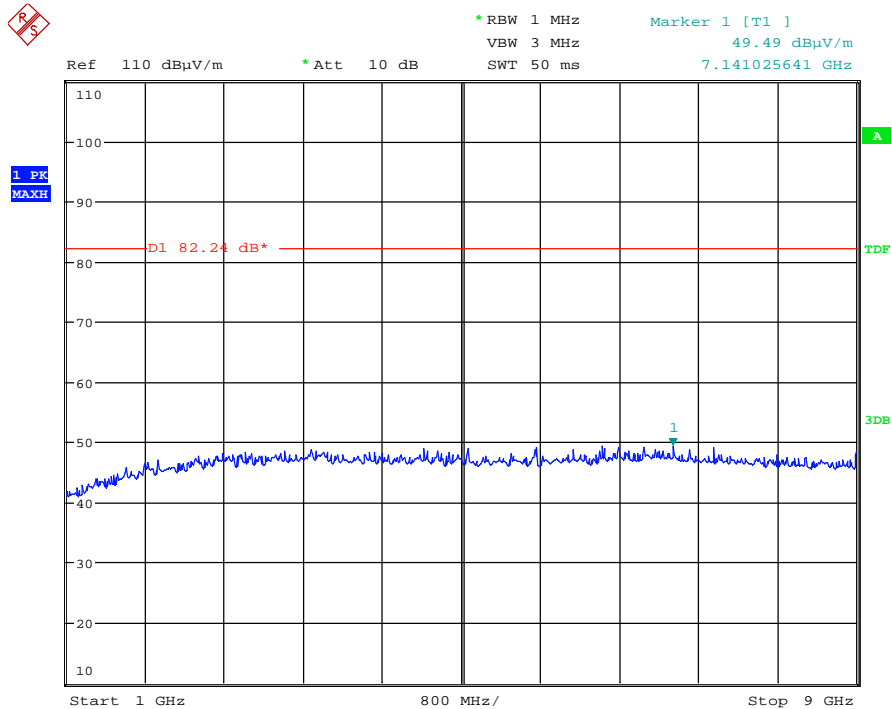

Date: 25.OCT.2011 15:06:19

AMPLIFIER GAIN – CONDUCTED – DOWNLINK

Ambient temperature = 22°C
 Relative humidity = 42%
 Supply voltage = +110Vac
 Channel number = See test results

Radio Laboratory

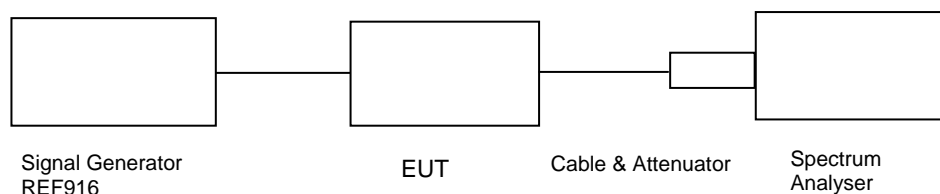

The EUT was set up as shown above. The signal generator level was increased in steps of 1dB till compression point was reached, wherein there was no corresponding increase in output for a known increase in input. The level on the signal generator was noted along with the output level. The input was then increased by 10dB and the corresponding output level was recorded. The system was calibrated for any losses, the gain and output power were calculated and produced below.

Results:

Frequency (MHz)	Signal Generator input level (dBm)	Input Cable Loss (dB)	Output Cable & Attenuator loss (dB)	Level at Spectrum Analyser (dBm)	Gain (dB)	Conducted Output Power (dBm)	Gain after 10dB input level increase (dB)
869.0	-46	0.22	30.40	3.68	80.30	34.08	70.21
881.5	-47	0.34	30.41	3.69	81.44	34.10	71.47
894.0	-47	0.24	30.53	3.34	81.11	33.87	71.17

Notes: The signal generator input was increased by 10dB and the level of the output signal was remeasured.

Test equipment used:

Type Of Equipment	Maker/ Supplier	Model No	Serial No	TRaC Ref No	Actual Equipment Used
Spectrum Analyser	Rohde & Schwarz	FSU46	100021/046	UH281	X
Attenuator	N/A	N/A	N/A	CIN E90	X
Attenuator	Bird	N/A	N/A	220	X
Cable	TRaC	N/A	N/A	UH271	X
Cable	TRaC	N/A	N/A	UH272	X
Cable	TRaC	N/A	N/A	UH270	X
Signal Generator	Rohde & Schwarz	Vector Signal Generator	255812	REF916	X

AMPLIFIER INTERMODULATION SPURIOUS EMISSIONS – CONDUCTED – DOWNLINK

Ambient temperature = 22°C
 Relative humidity = 42%
 Supply voltage = +110Vac

Radio Laboratory

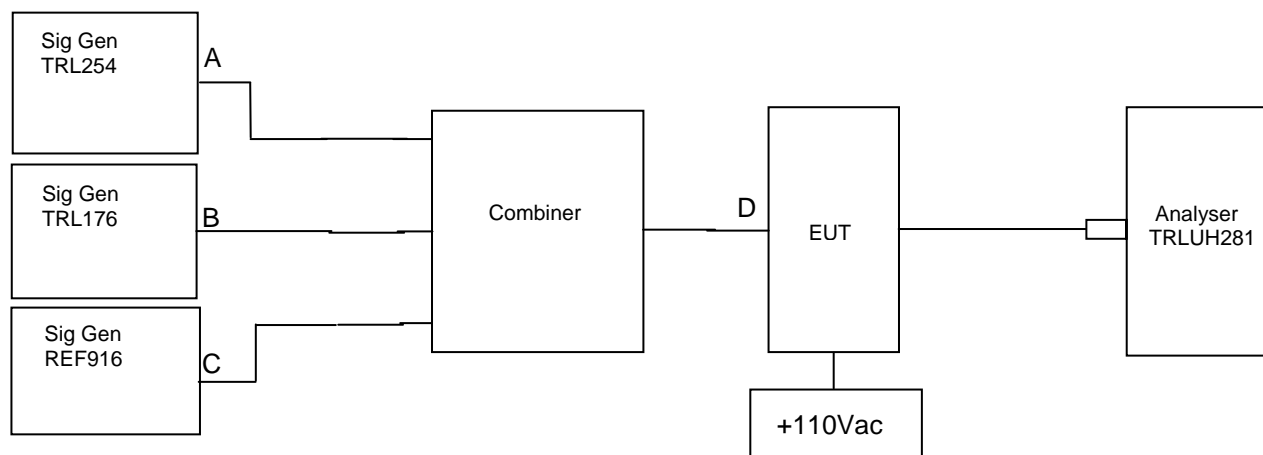

The intermodulation and spurious products were measured with the amplifier operating at maximum gain. A three tone test was conducted using the equipment as above. The input power level was adjusted so the level at point D was 10dB above the maximum input. The cable and attenuator loss between the EUT and the spectrum analyser was 31dB.

Results:

RF Input Frequency (MHz)			Highest Intermodulation Product Level (dBm)	Limit (dBm)
869.0	881.5	894.0	-22.86 @ 901.832MHz	-13

Sweep data is shown on the next page.

Test equipment used:

Type Of Equipment	Maker/ Supplier	Model No	Serial No	TRaC Ref No	Actual Equipment Used
Spectrum Analyser	R&S	FSU46	100021/046	UH281	X
Signal Generator	Rohde & Schwarz	SMBV100a	255812	REF916	X
Signal Generator	Marconi	2042	119388/080	TRL176	X
Signal Generator	Marconi	2042	119562/021	TRL254	X

Intermodulation Close view

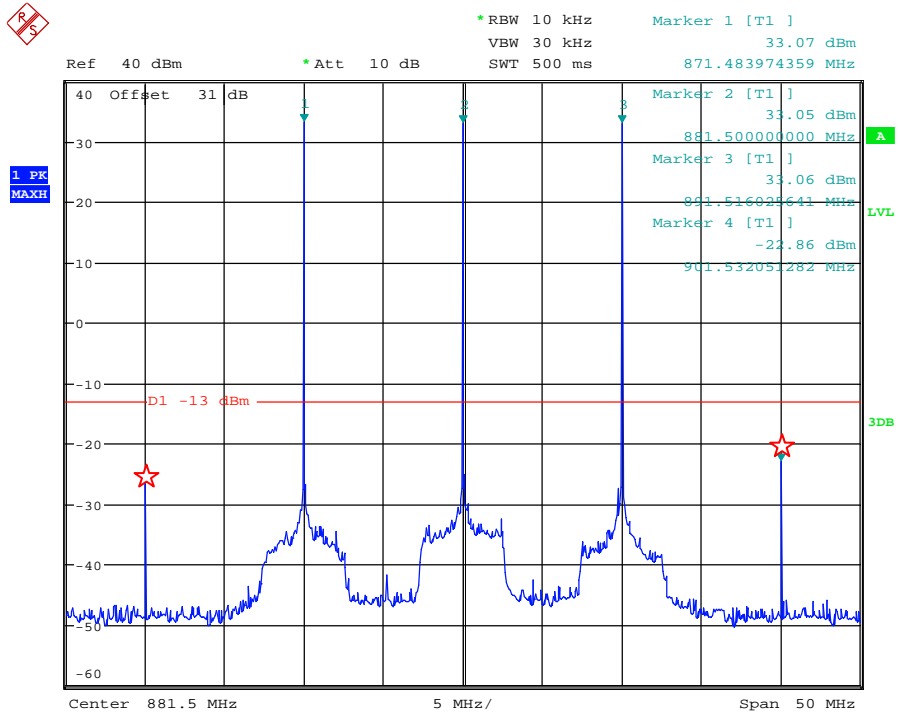

Date: 27.OCT.2011 10:47:52

Intermodulation wide view

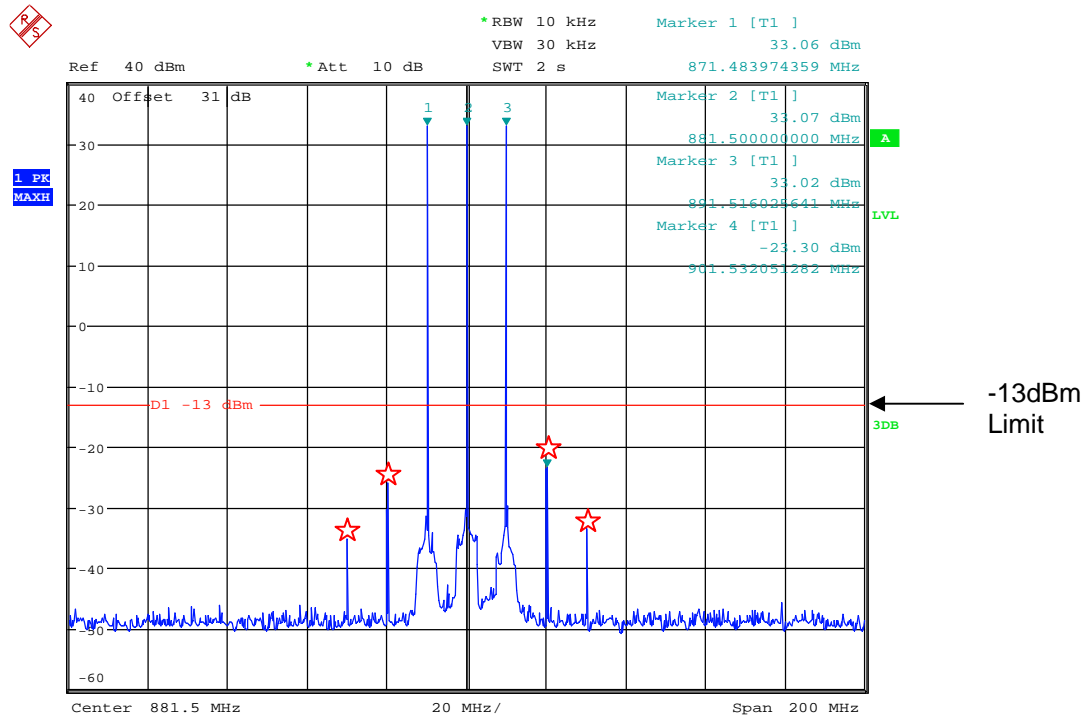

Date: 27.OCT.2011 10:48:25

The above plots show that all products (designated by ☆) are below the spurious limit.

Intermodulations Scan 9kHz-150kHz

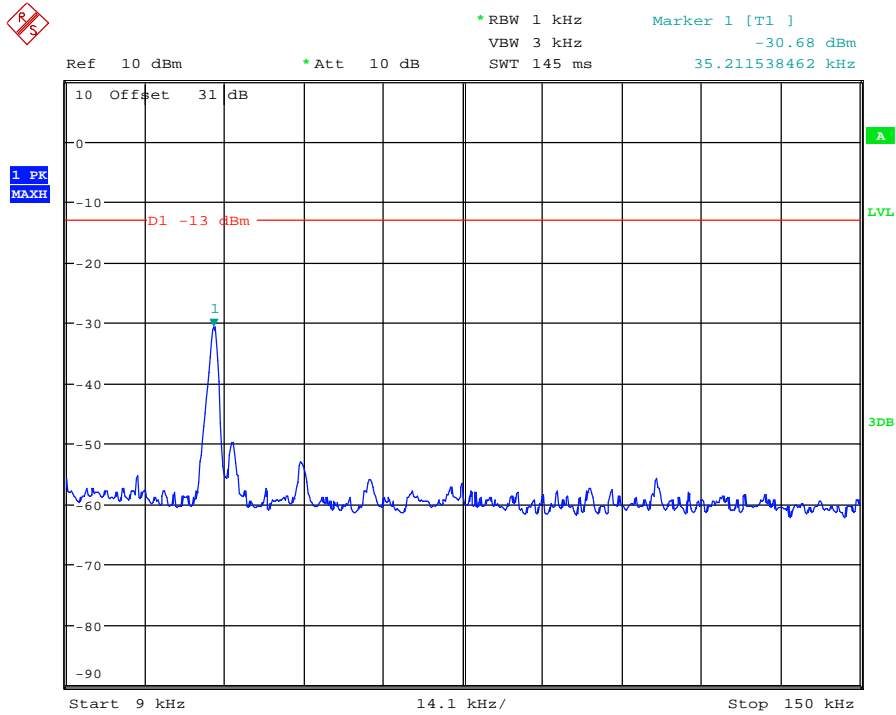

Date: 27.OCT.2011 10:51:08

Intermodulations Scan 150kHz-30MHz

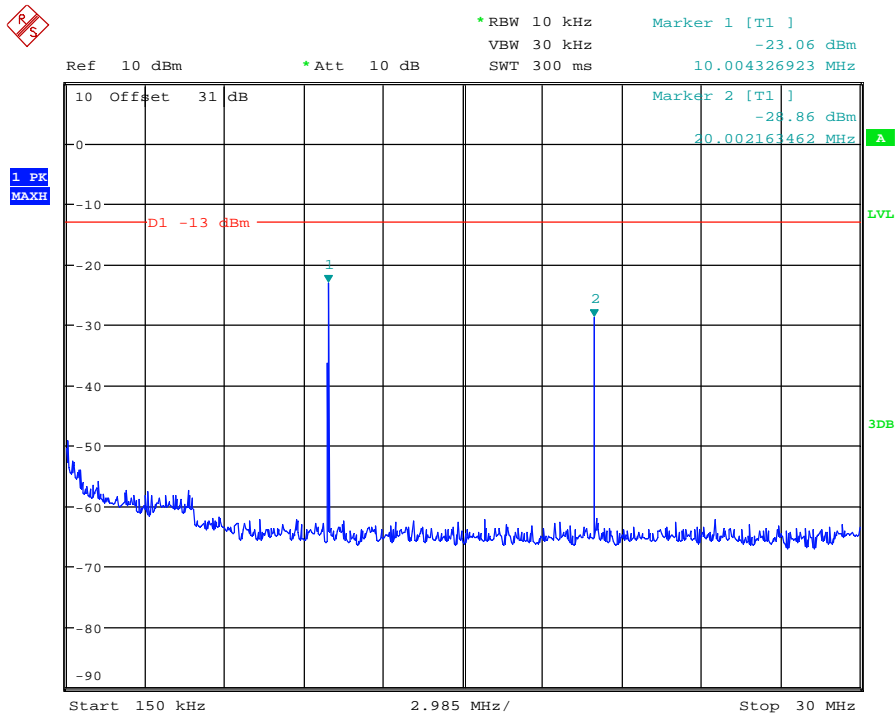

Date: 27.OCT.2011 10:52:14

Intermodulations Scan 30MHz-1GHz

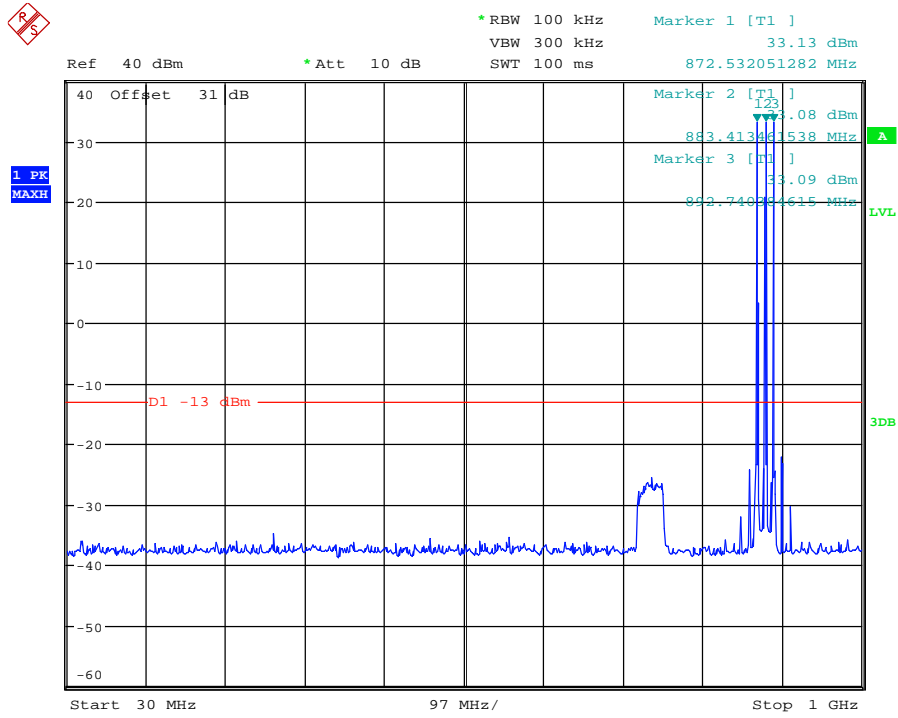

Date: 27.OCT.2011 11:00:17

Intermodulations Scan 1GHz-5GHz

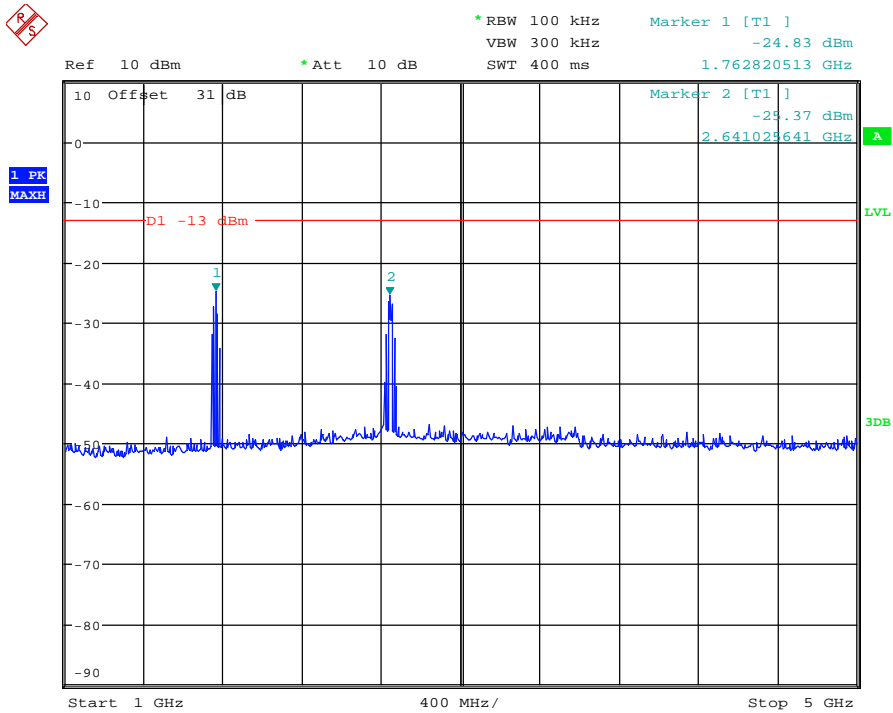

Date: 27.OCT.2011 11:01:20

Intermodulations Scan 5GHz-9GHz

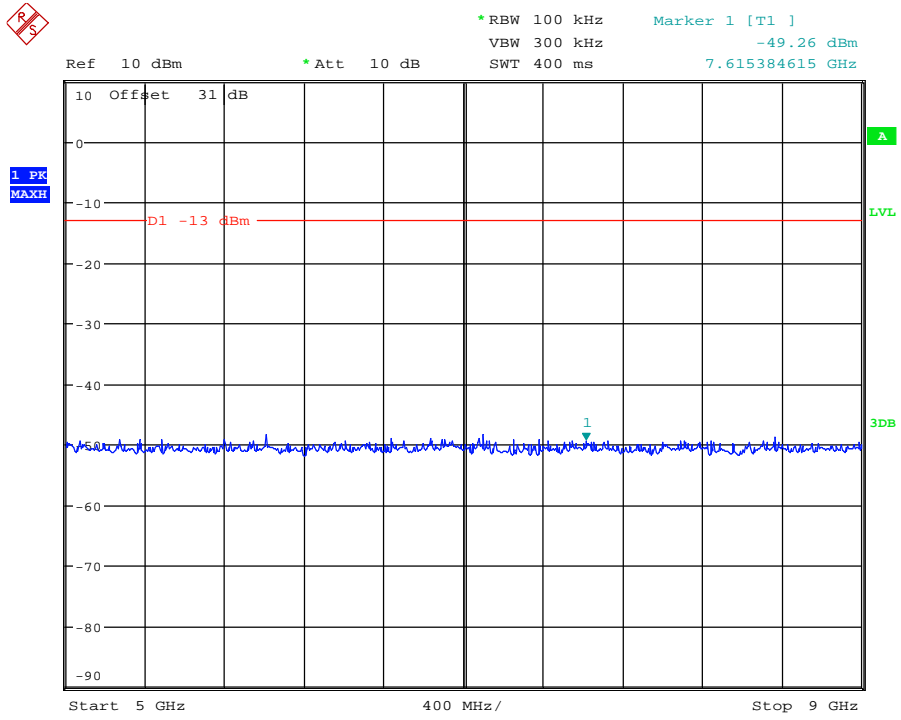

Date: 27.OCT.2011 11:02:41

AMPLIFIER MODULATED CHANNEL TEST – CONDUCTED – DOWNLINK

Ambient temperature = 22°C
 Relative humidity = 42%
 Supply voltage = +110Vac
 Channel number = See test results

Radio Laboratory

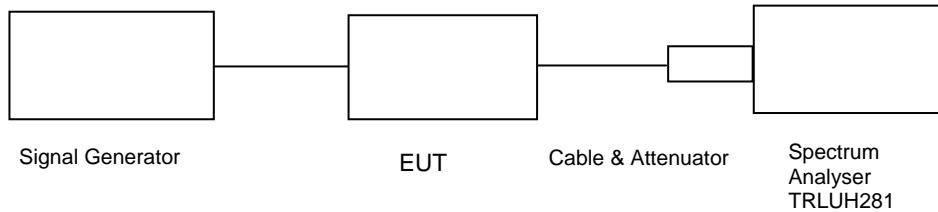

This test was performed to show that the amplifier does not alter the input signal in any way. The input signal was set beyond compression point and modulated with different schemes given below. The plots show the signal measured at the signal generator (black) and the signal measured at the output of the EUT (blue).

Note: The cables and attenuators had the following losses.

1. Cable and attenuator losses between EUT and spectrum analyser were about 30.5dB
2. Cable loss between signal generator and EUT was about 0.5dB
3. See Table below for 99% Power Occupied Bandwidth

Results:

Frequency Of Operational Channel	Occupied Bandwidth for each modulation type (kHz)		
	GSM	CDMA	W-CDMA
Bottom	245.192	1262.820	4166.667
Middle	243.587	1259.615	4182.692
Top	241.987	1259.615	4166.667

Note: For each type of signal, the most appropriate filter bandwidth was used which was just wide enough to pass the signal

Test Equipment Used:

Type Of Equipment	Maker/ Supplier	Model No	Serial No	TRaC Ref No	Actual Equipment Used
Spectrum Analyser	R&S	FSU46	100021/046	UH281	X
Signal Generator	Agilent	E4438C	N/A	N/A	X

869.0 MHz Signal Generator and EUT deviation set to CDMA

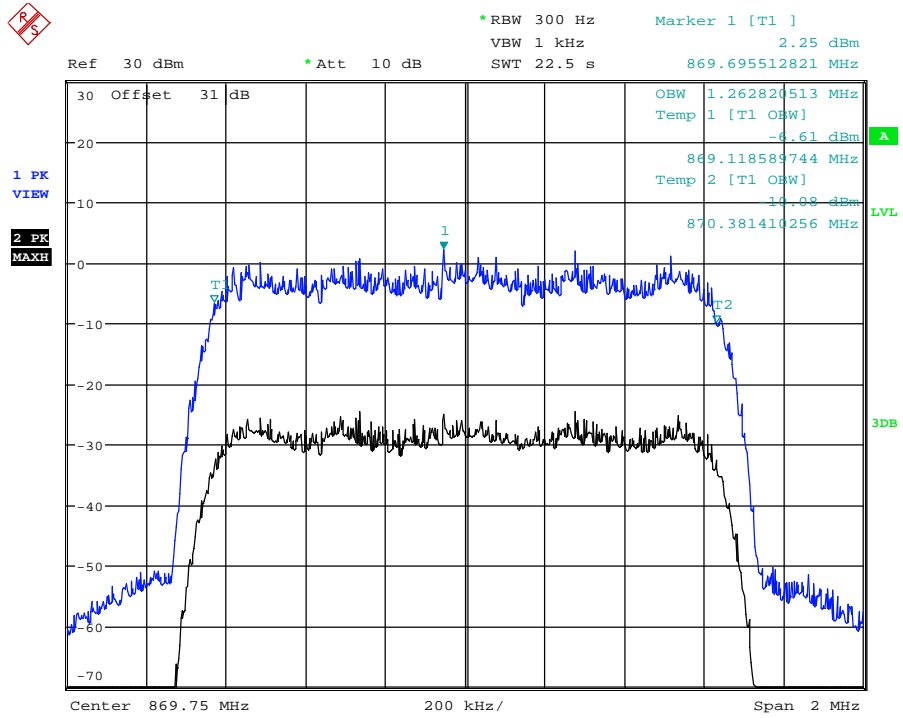

Date: 31.OCT.2011 09:28:27

881.5 MHz Signal Generator and EUT deviation set to CDMA

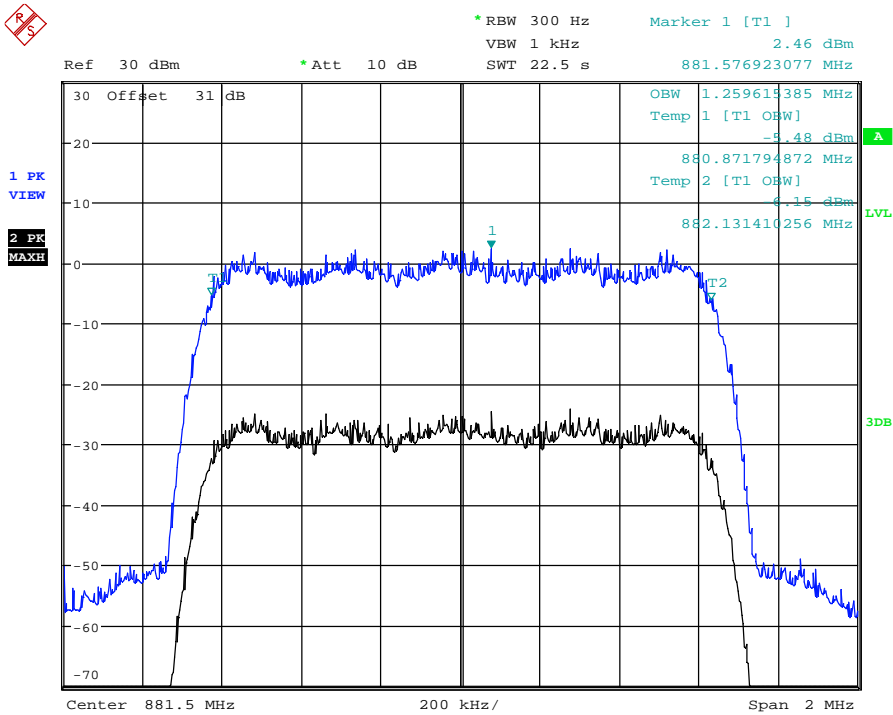

Date: 31.OCT.2011 09:36:36

894.0 MHz Signal Generator and EUT deviation set to CDMA

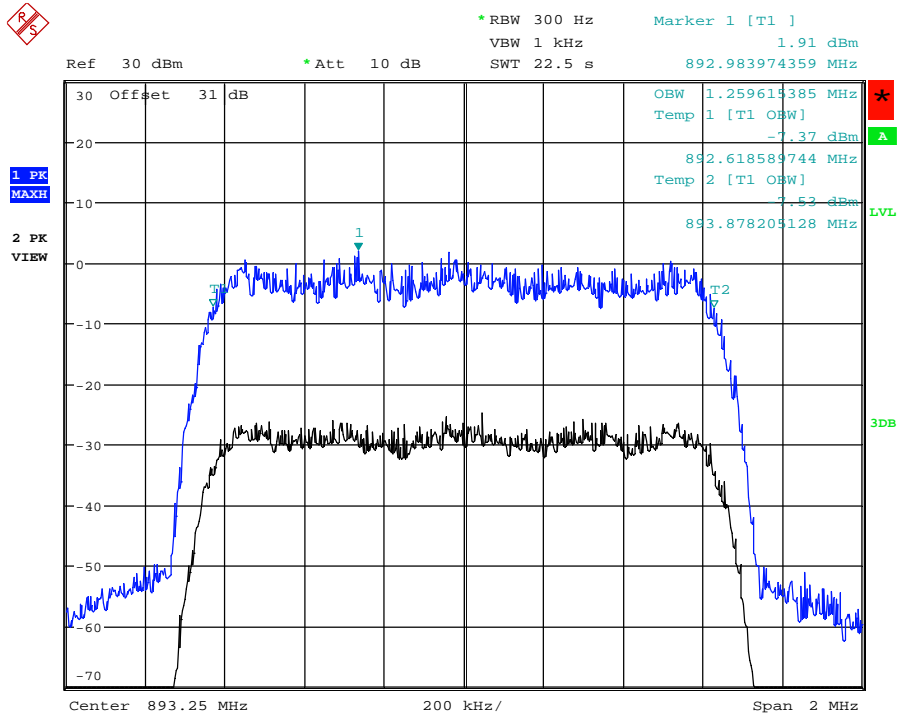

Date: 31.OCT.2011 09:43:37

869.0 MHz Signal Generator and EUT deviation set to W-CDMA

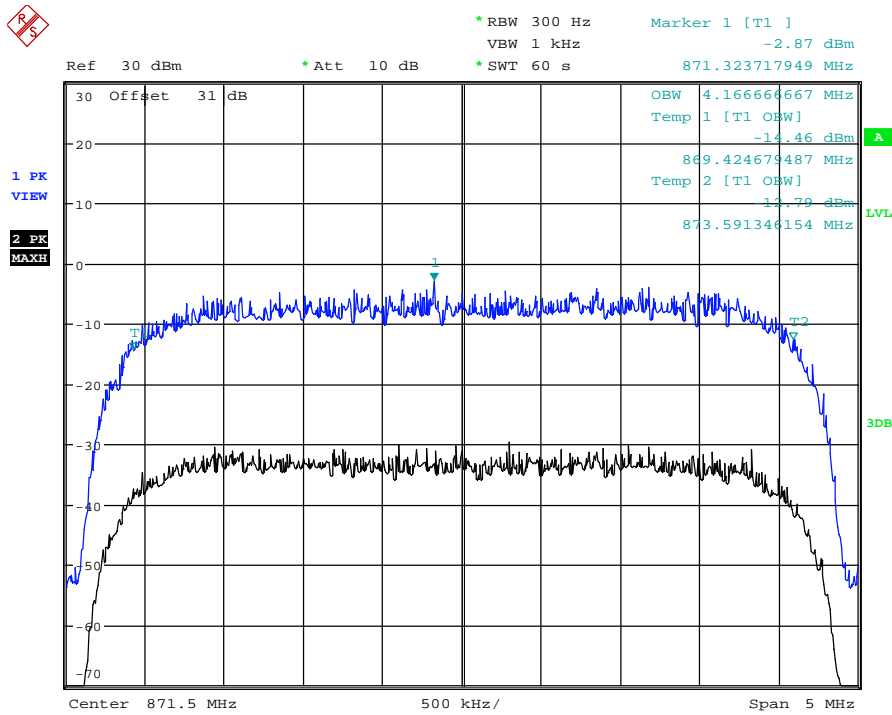

Date: 31.OCT.2011 10:18:28

881.5 MHz Signal Generator and EUT deviation set to W-CDMA

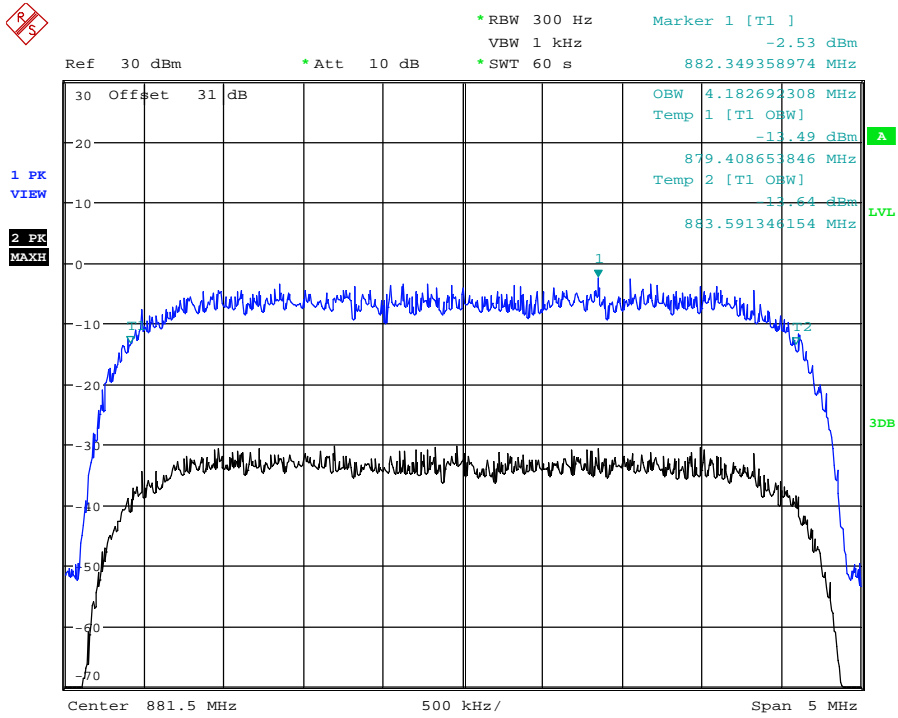

Date: 31.OCT.2011 10:26:22

894.0 MHz Signal Generator and EUT deviation set to W-CDMA

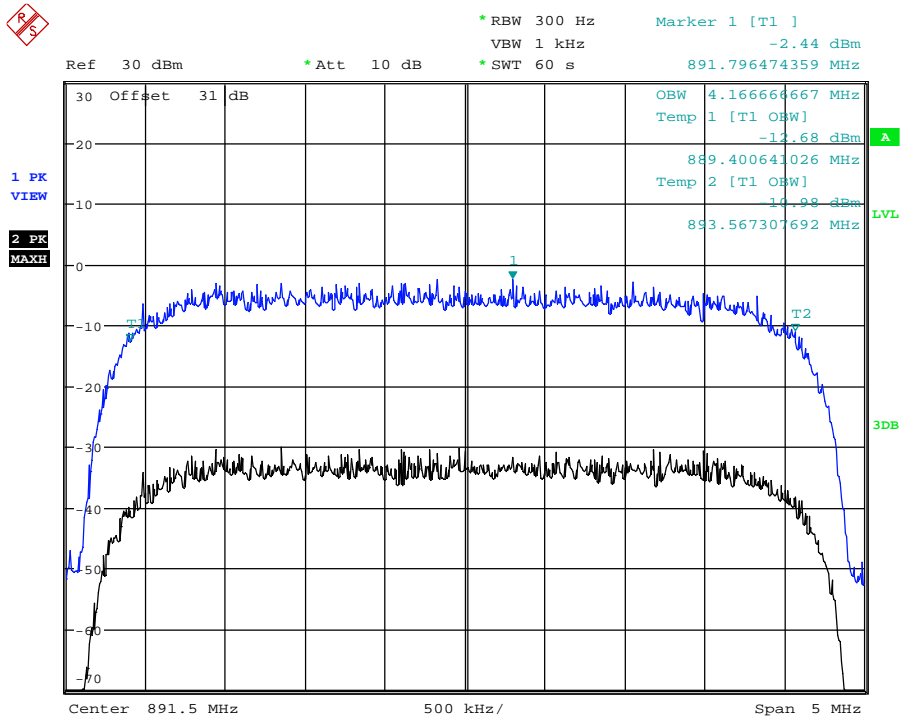

Date: 31.OCT.2011 10:33:01

869.0 MHz Signal Generator and EUT deviation set to GSM

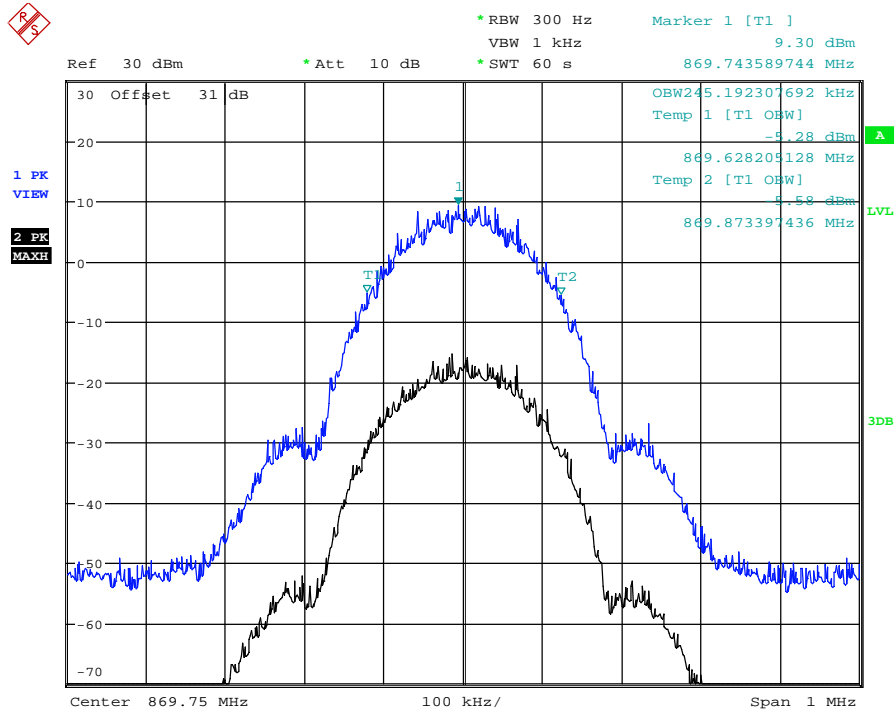

Date: 31.OCT.2011 10:12:55

881.5 MHz Signal Generator and EUT deviation set to GSM

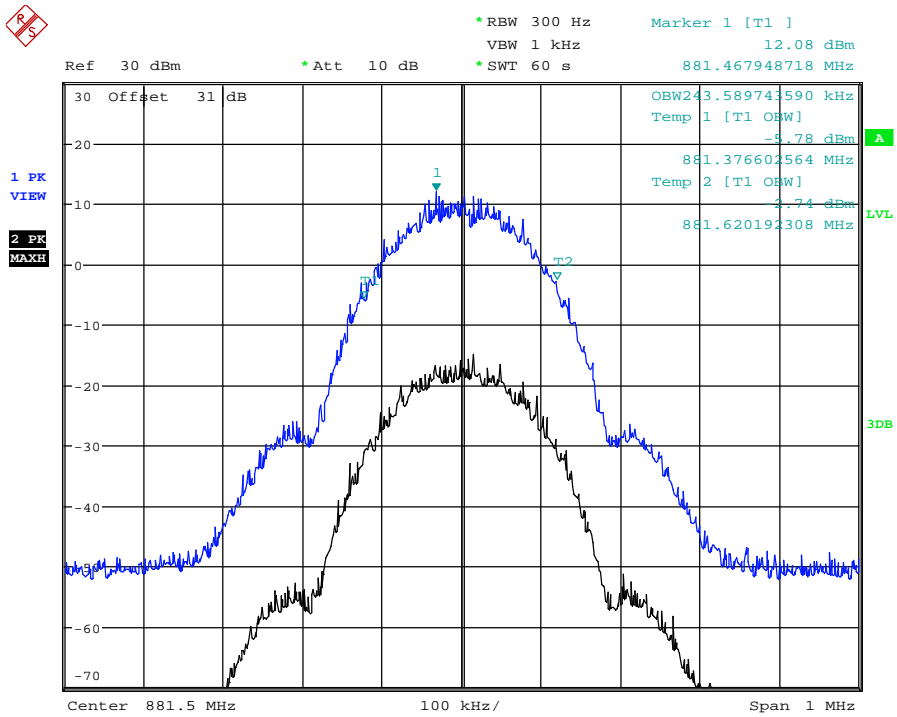

Date: 31.OCT.2011 10:04:51

894 MHz Signal Generator and EUT deviation set to GSM

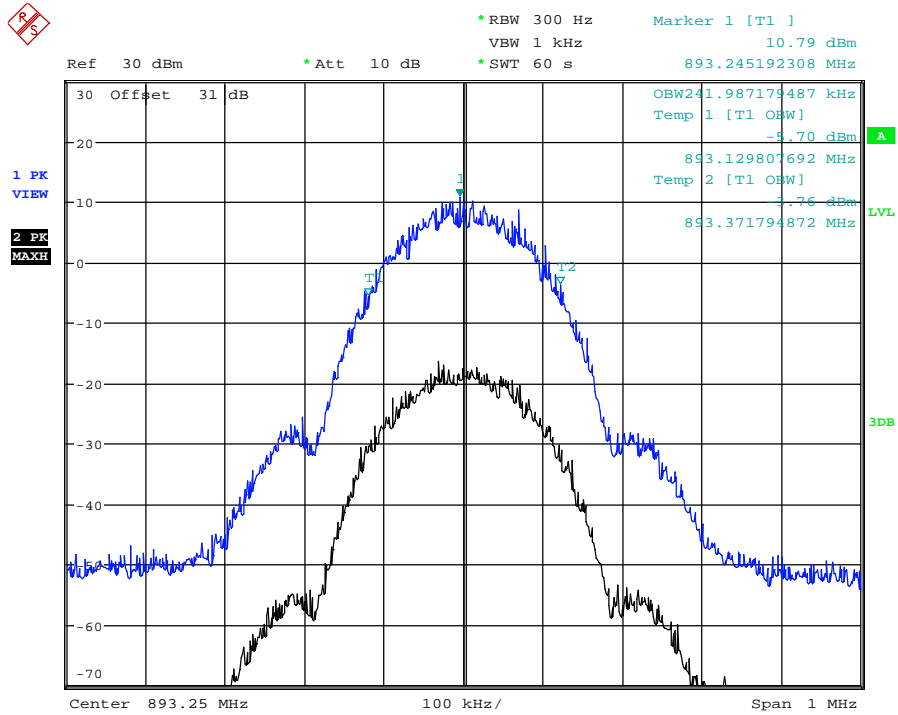

Date: 31.OCT.2011 09:51:39

The above plots depicting the output waveshape show no measurable distortion visible when compared to the input signal.

AMPLIFIER SPURIOUS EMISSIONS – CONDUCTED - DOWNLINK

Ambient temperature = 24°C
 Relative humidity = 65%
 Supply voltage = +110Vac

Radio Laboratory
 Test Signal = CW

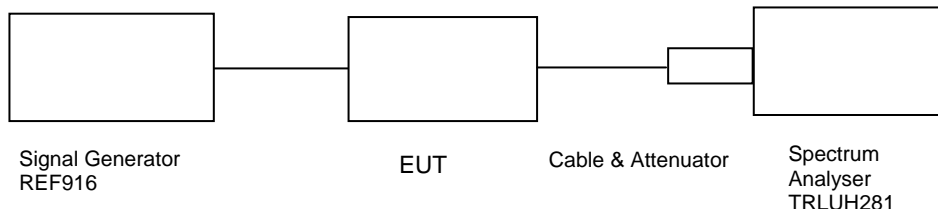

The test was set up as per the diagram. The level at the input was adjusted to compensate for the loss of the interconnecting cable. The unit was tested operating at maximum power and on three test frequencies.

The Spurious limit was calculated as follows:

On any frequency removed from the assigned frequency by more than 250% of the authorised bandwidth

At least $43 + 10 \log P$ dB

$$(10 \log P_{\text{watts}}) - (43 + 10 \log (P_{\text{watts}} / 1000)) = \text{LIMIT} = -13 \text{ dBm}$$

Results:

FREQUENCY RANGE	FREQ. (MHz)	MEASURED LEVEL (dBm)	ATTENUATOR & CABLE LOSSES (dB)	EMISSION LEVEL (dBm)	LIMIT (dBm)
9kHz – 9GHz	No Significant Emissions Within 20dB of Limit				-13

Test equipment used:

Type Of Equipment	Maker/ Supplier	Model No	Serial No	TRaC Ref No	Actual Equipment Used
Spectrum Analyser	Rohde & Schwarz	FSU46	100021/046	UH281	X
Cable	TRaC	N/A	N/A	UH271	X
Cable	TRaC	N/A	N/A	UH272	X
Signal Generator	Rohde & Schwarz	Vector Signal Generator	255812	REF916	X

869.0MHz 9kHz-150kHz

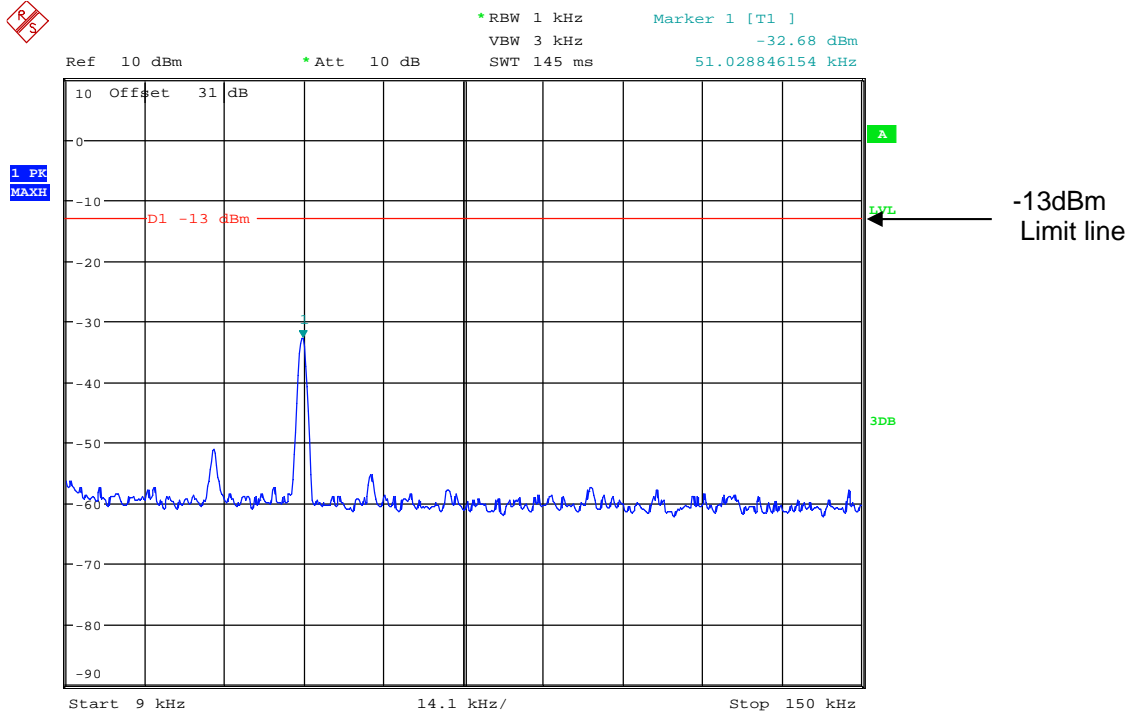

Date: 24.OCT.2011 10:28:14

869.0MHz 150kHz-30MHz

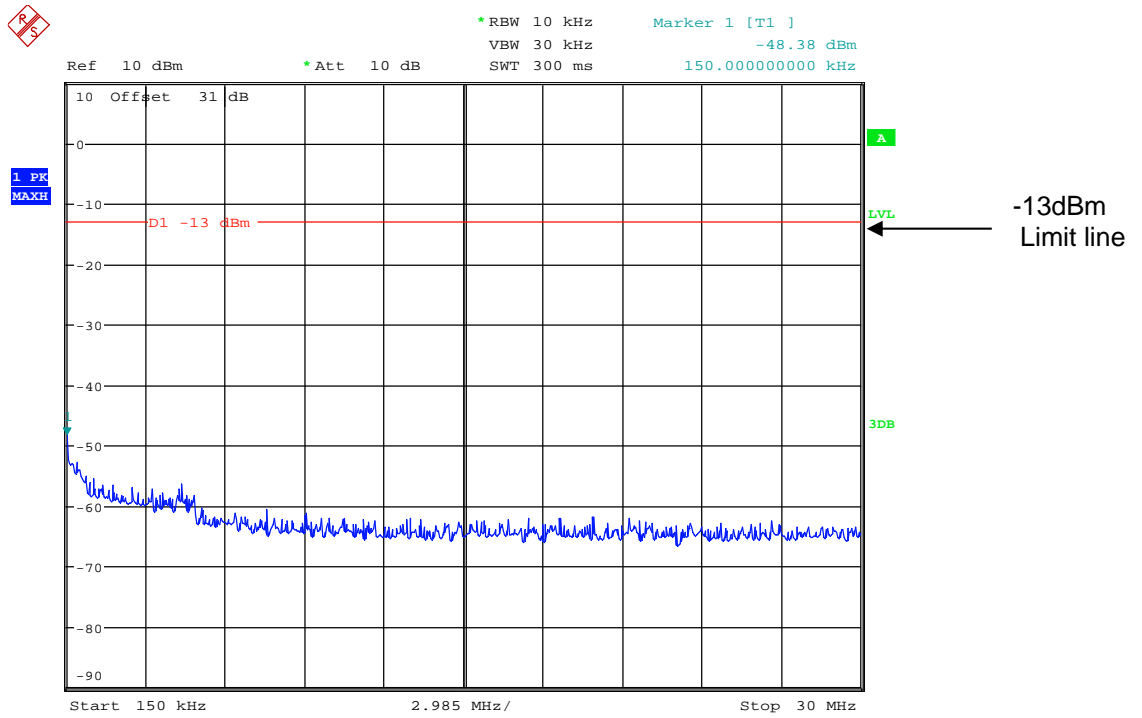

Date: 24.OCT.2011 10:28:56

869.0MHz 30MHz-1GHz

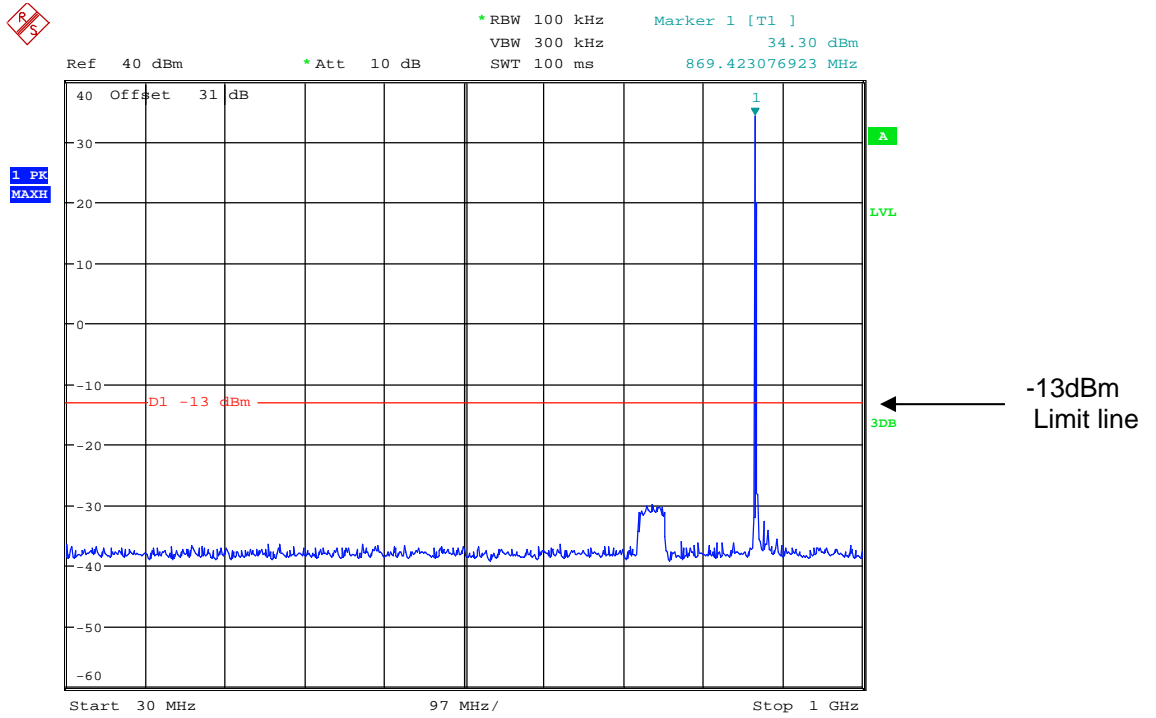

Date: 24.OCT.2011 10:43:48

869.0MHz 1GHz-5GHz

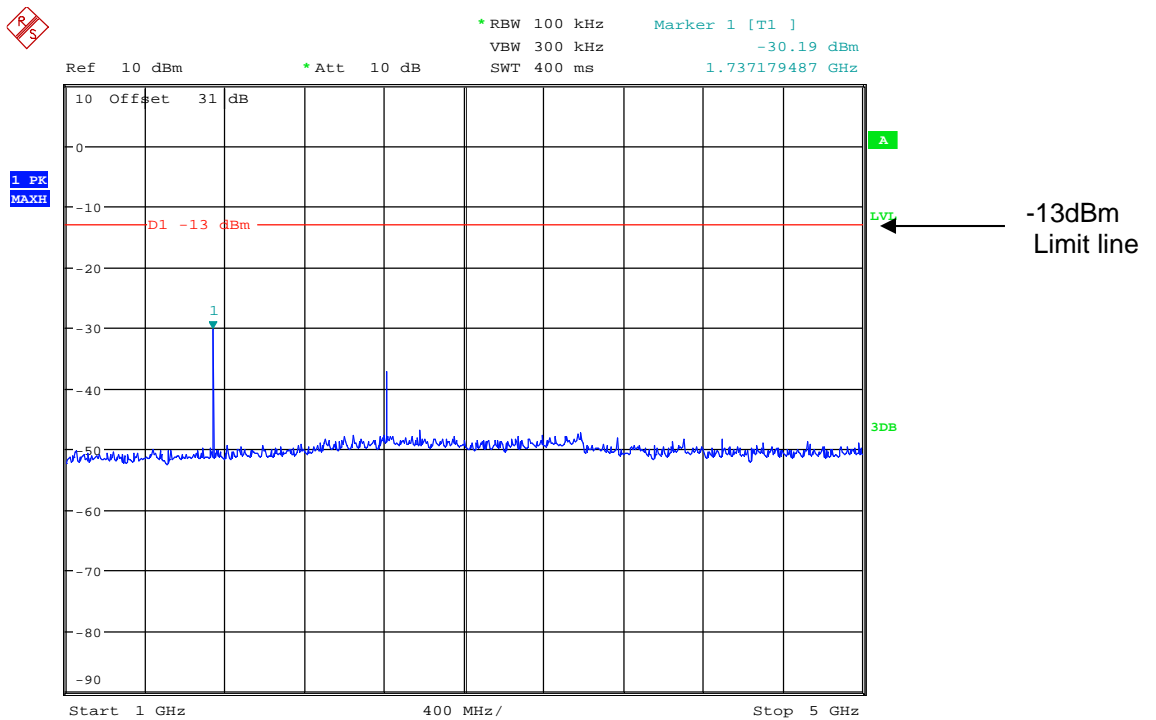

Date: 24.OCT.2011 10:45:12

869.0MHz 5GHz-9GHz

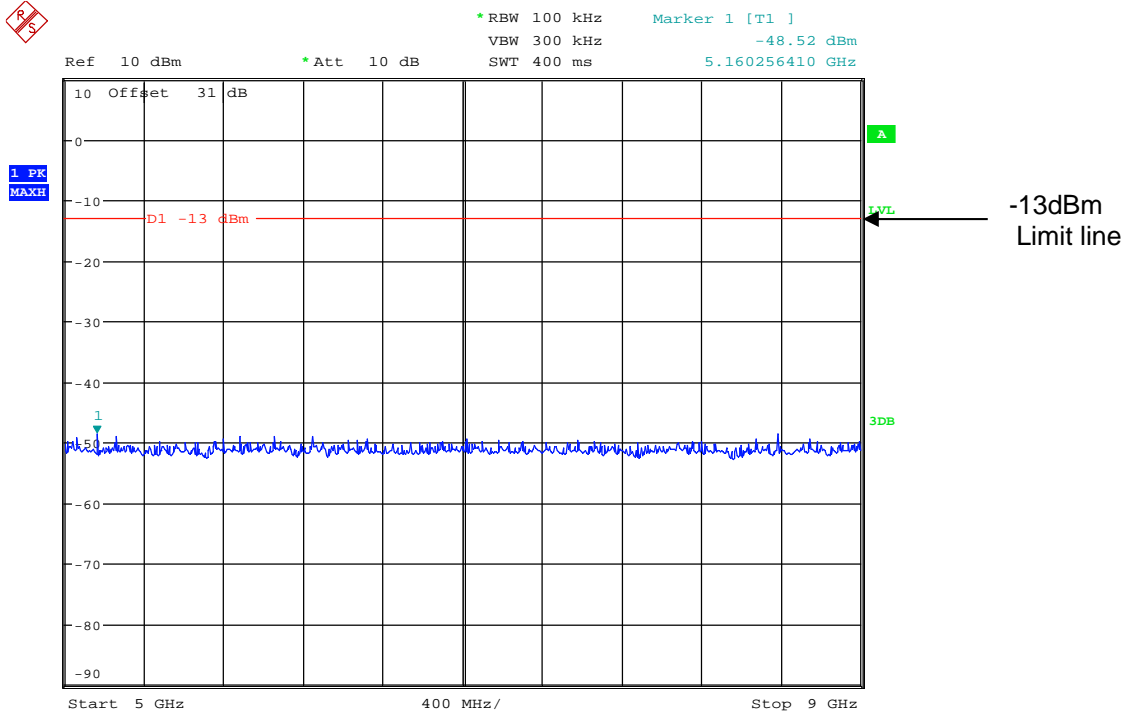

Date: 24.OCT.2011 10:45:44

881.5MHz 9kHz-150kHz

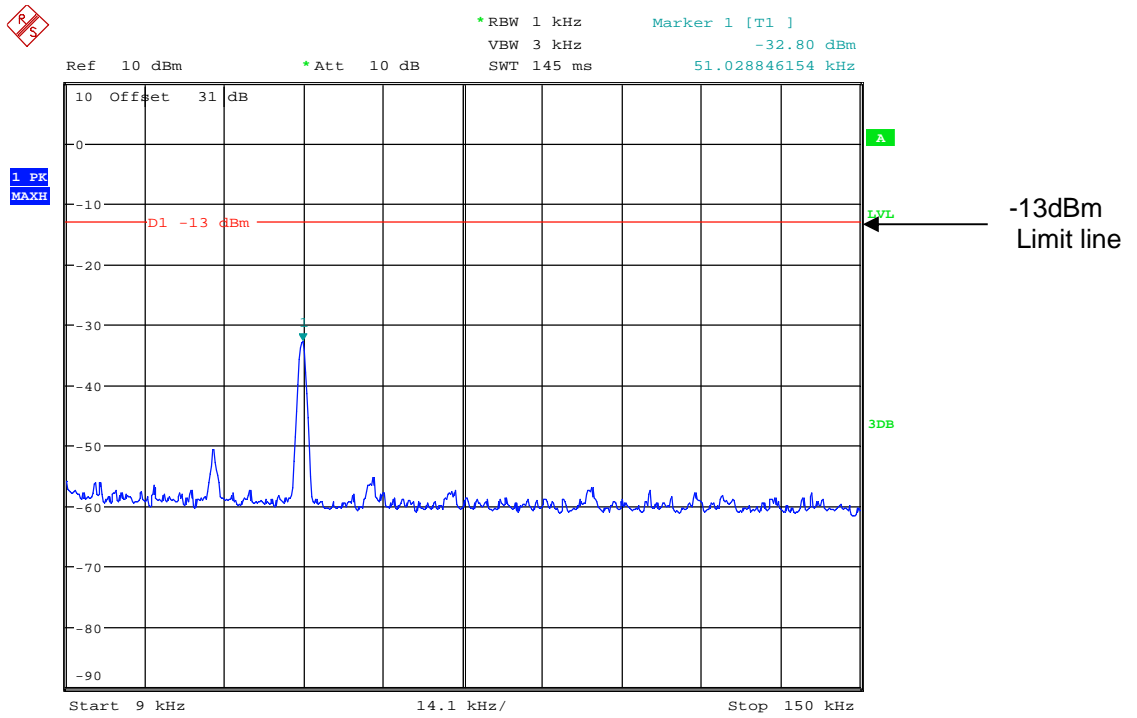

Date: 24.OCT.2011 10:48:39

881.5MHz 150kHz-30MHz

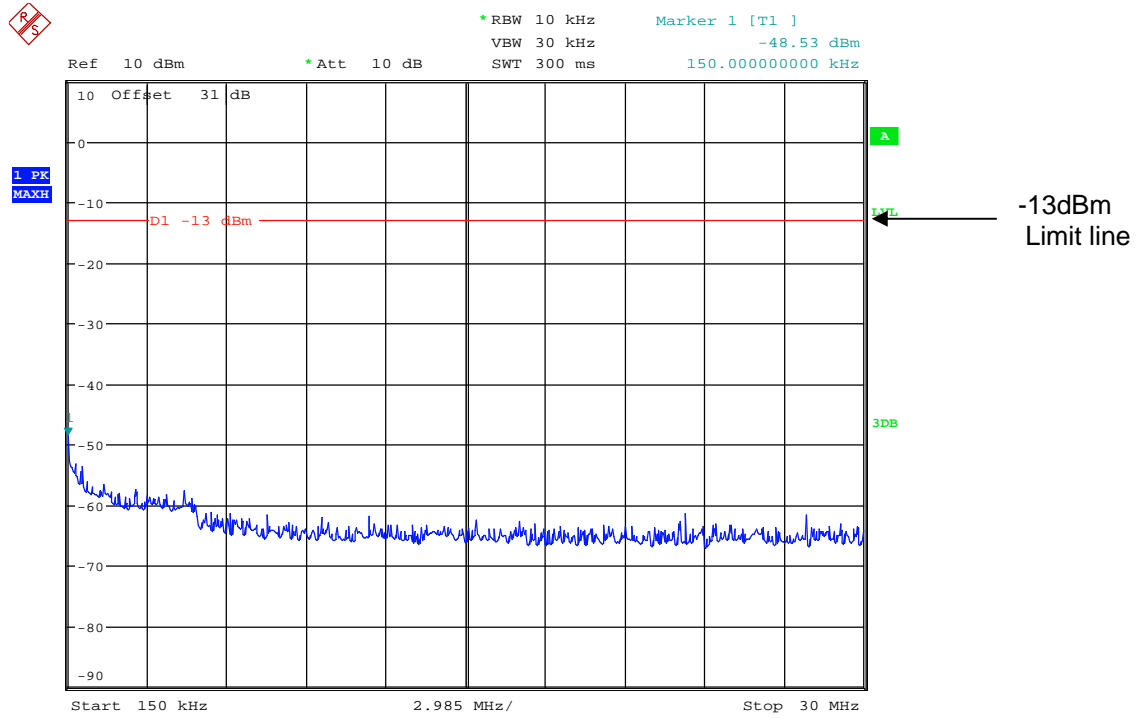

Date: 24.OCT.2011 10:49:03

881.5MHz 30MHz-1GHz

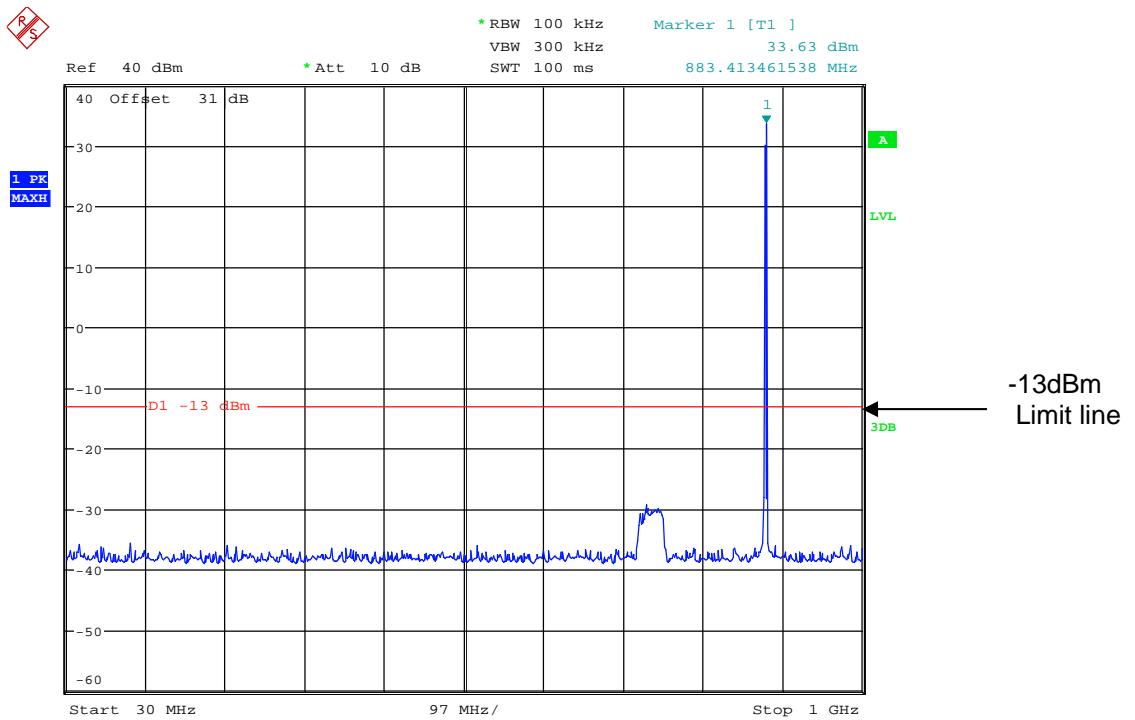

Date: 24.OCT.2011 10:49:41

881.5MHz 1GHz-5GHz

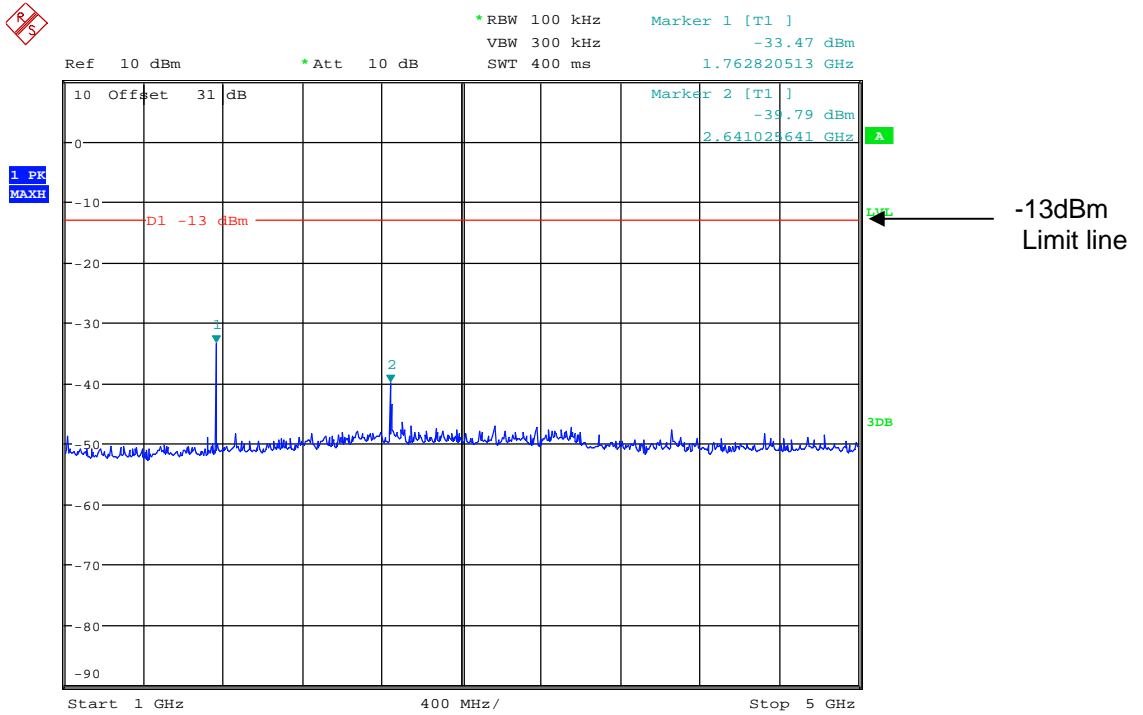

Date: 24.OCT.2011 10:50:16

881.5MHz 5GHz-9GHz

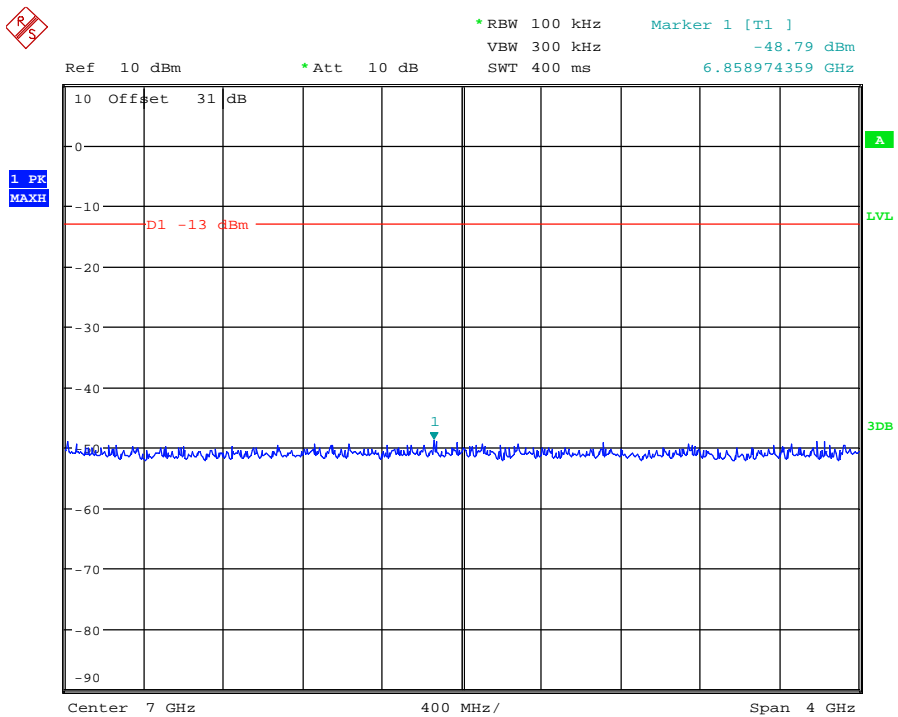

Date: 24.OCT.2011 10:50:53

894.0MHz 9kHz-150kHz

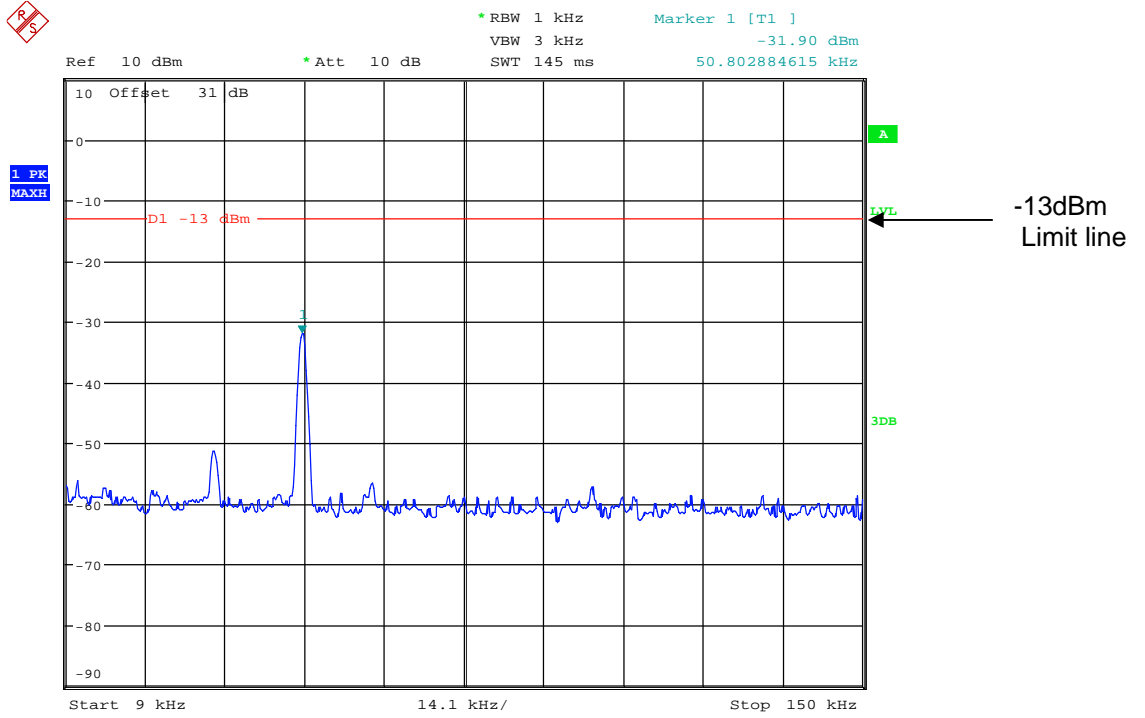

Date: 24.OCT.2011 10:51:44

894.0MHz 150kHz-30MHz

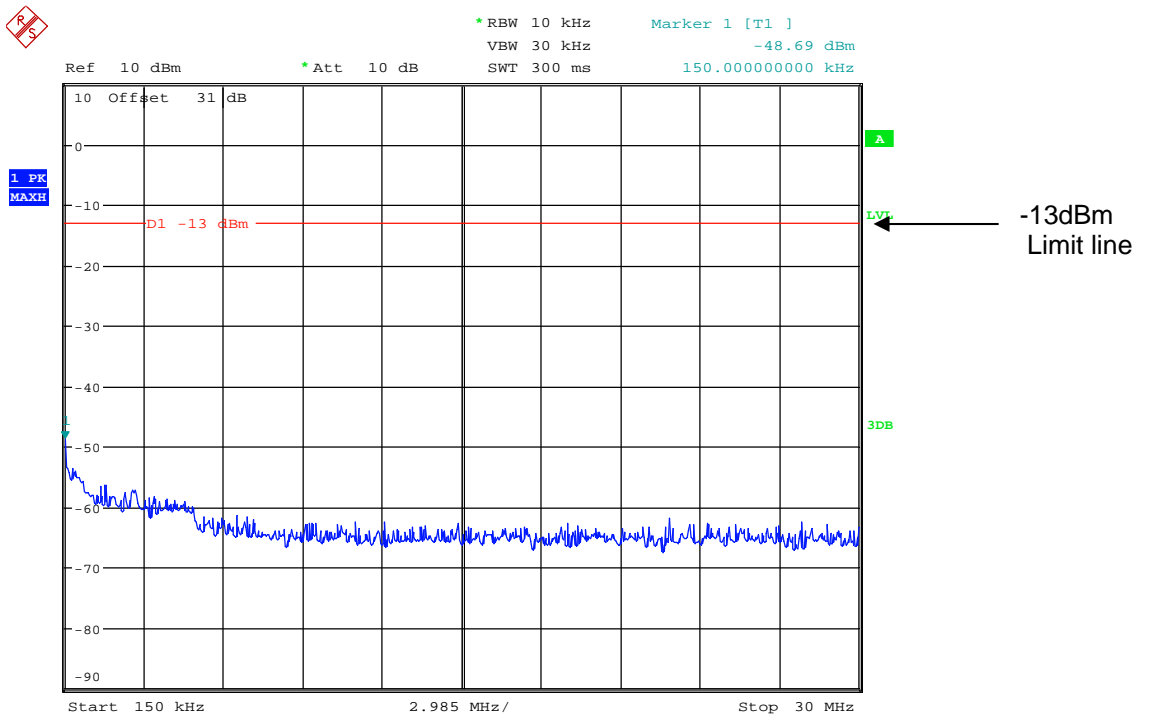

Date: 24.OCT.2011 10:52:10

894.0MHz 30MHz-1GHz

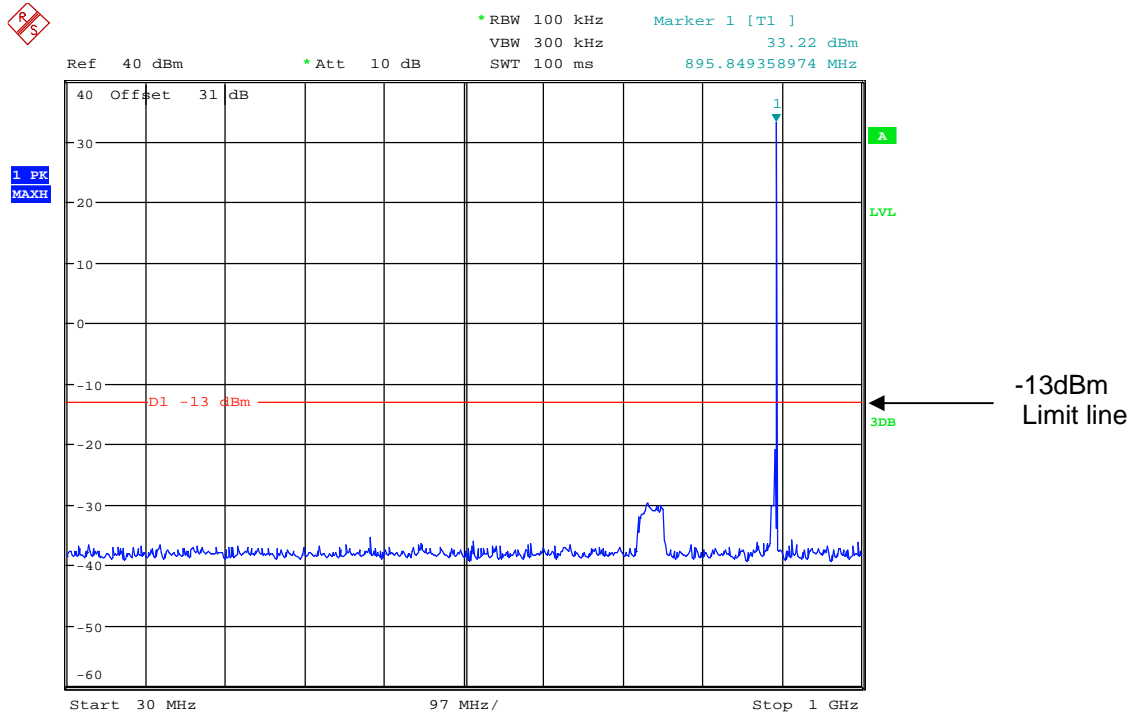

Date: 24.OCT.2011 10:52:42

894.0MHz 1GHz-5GHz

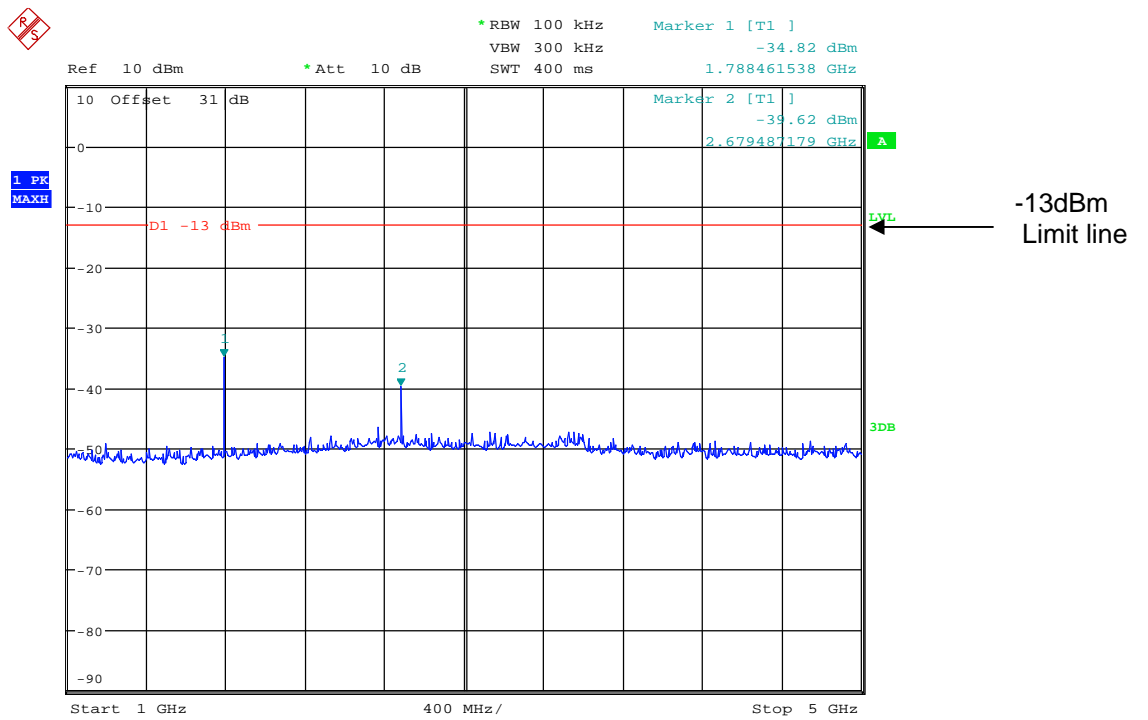

Date: 24.OCT.2011 10:53:23

894.0MHz 5GHz-9GHz



*RBW 100 kHz Marker 1 [T1]
VBW 300 kHz -48.45 dBm
SWT 400 ms 5.089743590 GHz

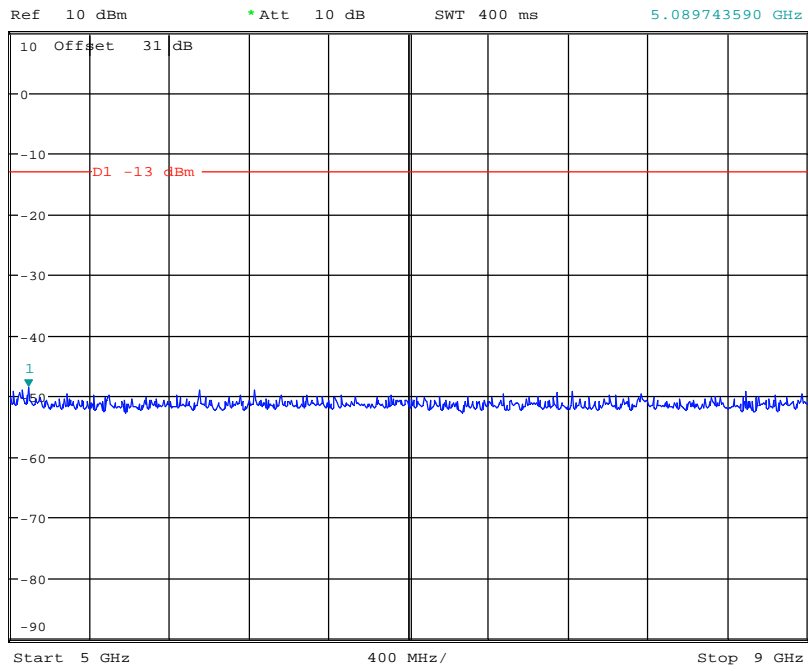

-13dBm
Limit line

Date: 24.OCT.2011 10:53:48

AMPLIFIER SPURIOUS EMISSIONS – RADIATED – DOWNLINK

Ambient temperature = 22°C
 Relative humidity = 46%
 Conditions = ALSR
 Supply voltage = +110Vac
 Supply Frequency = N/A

Test Signal = CW

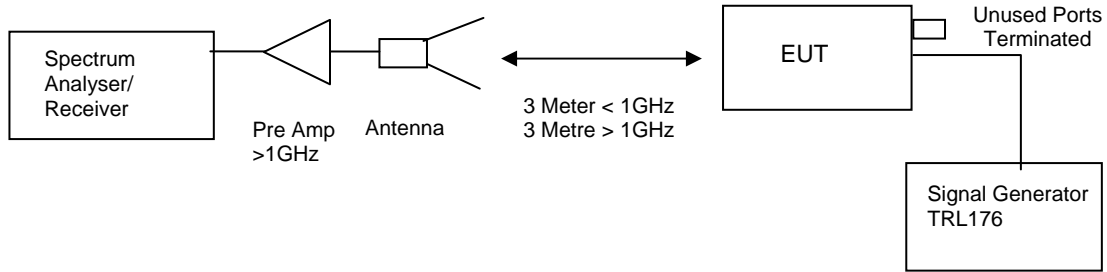

The test was set up as per the diagram. The level at the input was adjusted to compensate for the loss of the interconnecting cable. The unit was tested operating maximum power on three test frequencies with a 50 ohm load on the output. The unit was also tested with the signal generator replaced by another 50ohm load.

The Spurious limit was calculated as follows:

On any frequency removed from the assigned frequency by more that 250% of the authorised bandwidth

At least 43 + 10 log P dB

$$(10\log P_{\text{watts}}) - (43+10\log (P_{\text{watts}} / 1000)) = \text{LIMIT} = -13 \text{ dBm}$$

Results:

FREQUENCY RANGE	FREQ. (MHz)	MEAS. Rx. (dBµV)	CABLE LOSS (dB)	ANT FACTOR	FIELD STRENGTH (dBµV/m)	CALCULATED EIRP (dBm)	LIMIT (dBm)
30MHz – 9GHz	No Significant Emissions Within 20dB of Limit.						-13

Test equipment used:

Type Of Equipment	Maker/ Supplier	Model No	Serial No	TRaC Ref No	Actual Equipment Used
Horn	Emco	3115	9010-3580	138	X
Spectrum Analyser	R&S	FSU46	100021/046	UH281	X
Pre Amplifier	HP	8449B	3008A016	572	X
Signal Generator	Marconi	2042	119388/080	176	X
Antenna	York	CBL611/A	1618	UH191	X
Receiver	R&S	ESVS10	825892/006	UH04	X

869.0MHz 30MHz-1GHz

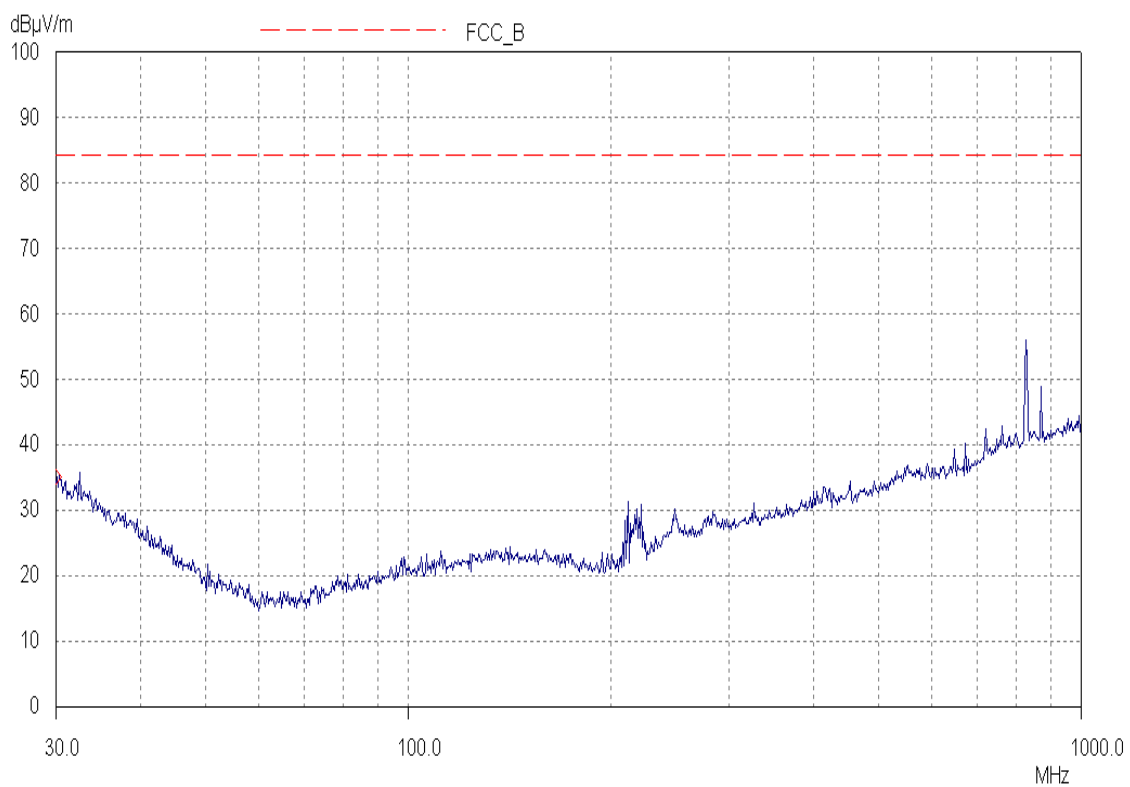

869.0MHz 1GHz-9GHz

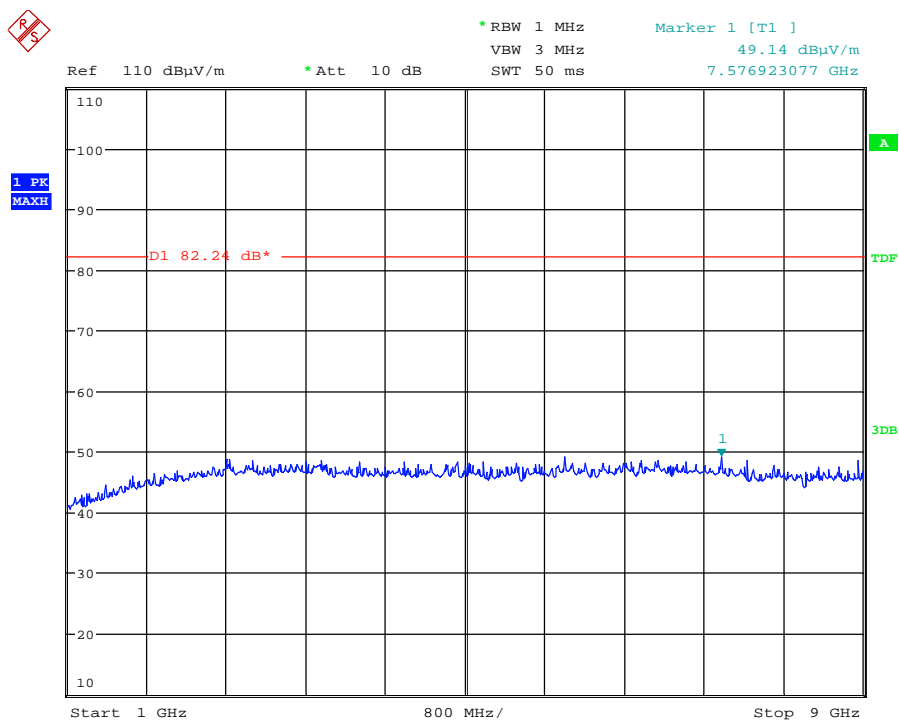

Date: 25.OCT.2011 14:33:49

881.5MHz 30MHz-1GHz

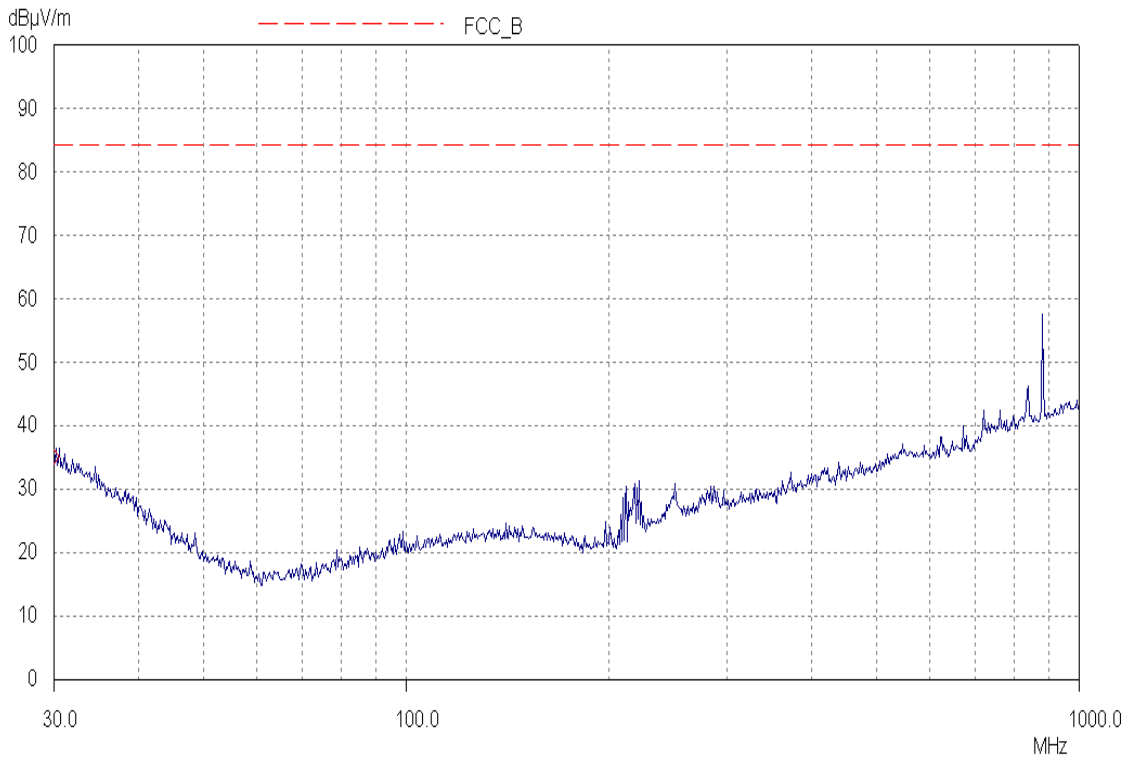

881.5MHz 1GHz-9GHz

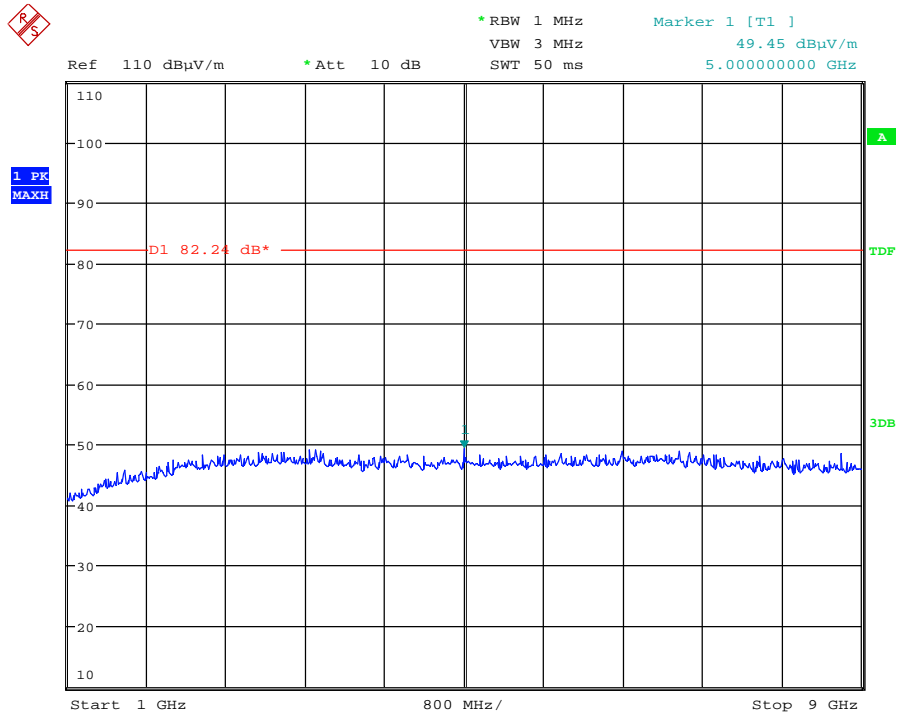

Date: 25.OCT.2011 14:34:12

894MHz 30MHz-1GHz

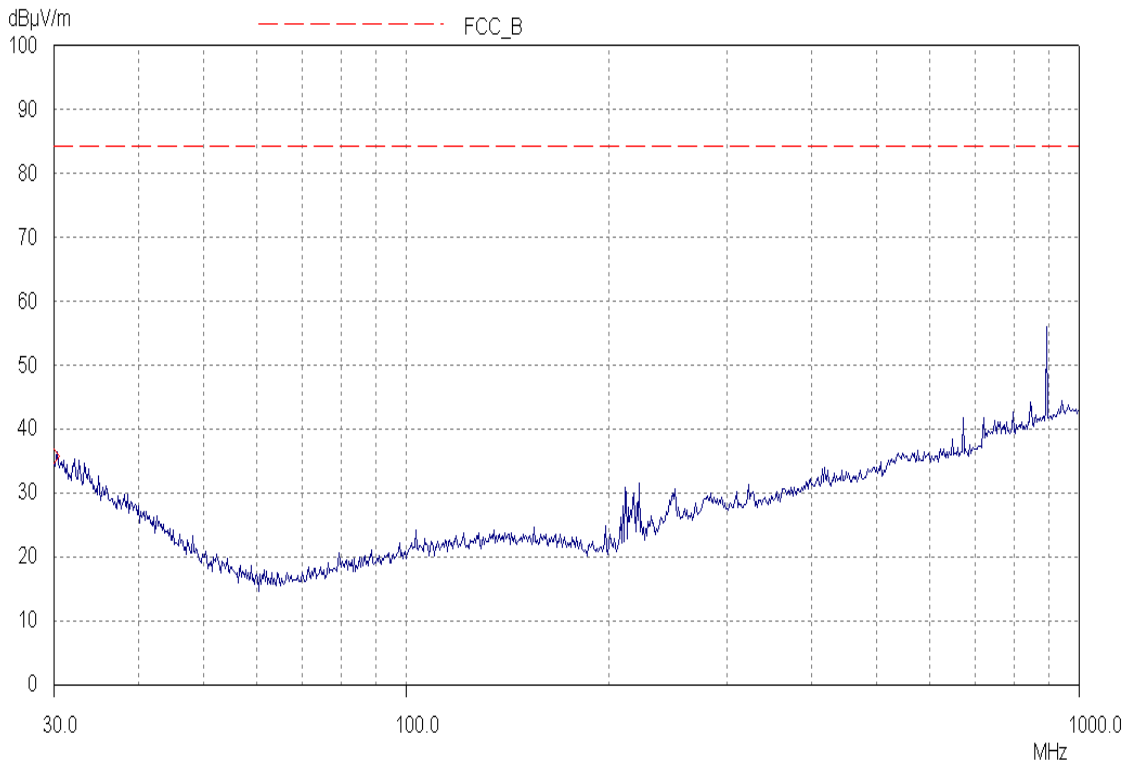

894MHz 1GHz-9GHz

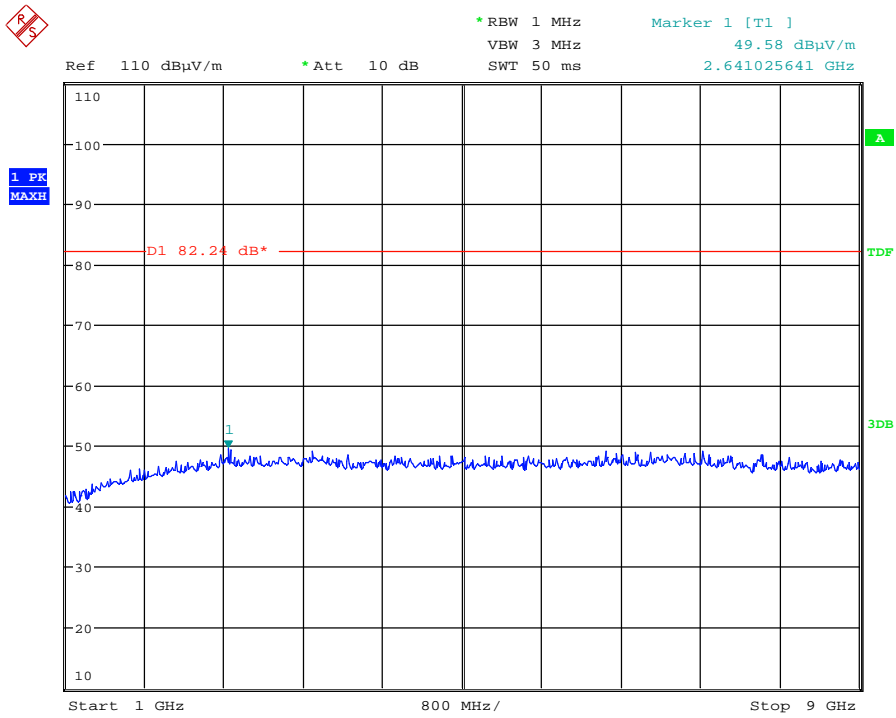

Date: 25.OCT.2011 14:34:48

ANNEX A
PHOTOGRAPHS

Photograph 1: Setup for conducted tests



Photograph 2: Setup for radiated tests



ANNEX B
APPLICANT'S SUBMISSION OF DOCUMENTATION LIST

APPLICANT'S SUBMISSION OF DOCUMENTATION LIST

a.	TCB	-	APPLICATION	[X]
		-	FEE	[X]
b.	AGENT'S LETTER OF AUTHORISATION	-		[X]
c.	MODEL(s) vs IDENTITY	-		[]
d.	ALTERNATIVE TRADE NAME DECLARATION(s)	-		[]
e.	LABELLING	-	PHOTOGRAPHS	[]
		-	DECLARATION	[]
		-	DRAWINGS	[]
f.	TECHNICAL DESCRIPTION	-		[X]
g.	BLOCK DIAGRAMS	-	Tx	[X]
		-	Rx	[]
		-	PSU	[]
		-	AUX	[]
h.	CIRCUIT DIAGRAMS	-	Tx	[X]
		-	Rx	[]
		-	PSU	[]
		-	AUX	[]
i.	COMPONENT LOCATION	-	Tx	[]
		-	Rx	[]
		-	PSU	[]
		-	AUX	[]
j.	PCB TRACK LAYOUT	-	Tx	[]
		-	Rx	[]
		-	PSU	[]
		-	AUX	[]
k.	BILL OF MATERIALS	-	Tx	[X]
		-	Rx	[]
		-	PSU	[]
		-	AUX	[]
l.	USER INSTALLATION / OPERATING INSTRUCTIONS	-		[X]

ANNEX C
EQUIPMENT CALIBRATION

TRaC Ref Number	Equipment Type	Manufacturer	Last Calibrated	Calibration Period	Due For Calibration
UH003	Receiver	R&S	13/01/2011	12	13/01/2012
UH004	Receiver	R&S	14/12/2010	12	14/12/2011
UH191	Bilog	Chase	08/11/2010	24	08/11/2012
UH253	1m Cable N type	TRAC	01/03/2011	12	01/03/2012
UH254	1m Cable N type	TRAC	01/03/2011	12	01/03/2012
UH269	1m Cable N type	TRAC	01/03/2011	12	01/03/2012
UH270	1m Cable N type	TRAC	01/03/2011	12	01/03/2012
UH271	1.5m Cable N type	TRAC	01/03/2011	12	01/03/2012
UH272	1.5m Cable N type	TRAC	01/03/2011	12	01/03/2012
UH273	2m Cable N type	TRAC	01/03/2011	12	01/03/2012
UH274	2m Cable N type	TRAC	01/03/2011	12	01/03/2012
UH281	Spectrum Analyser	R&S	10/02/2011	12	10/02/2012
UH288	1m Cable N type	N/A	01/03/2011	12	01/03/2012
UH293	K-Type Cable	Megaphase	24/11/2010	12	24/11/2011
UH378	3M Cable	TRaC	01/03/2011	12	01/03/2012
L139	1-18GHz Horn	EMCO	14/09/2011	24	14/09/2013
N/A	Vector Signal Generator	Agilent	03/02/2010	24	03/02/2012
L176	Signal Generator	Marconi	07/10/2011	12	07/10/2012
L572	Pre Amp	Agilent	24/11/2010	12	24/11/2011
L664	3M Cable	TRaC	01/03/2011	12	01/03/2012
REF916	Vector Signal Generator	R&S	13/12/2010	12	13/12/2011
L254	Signal Generator	Marconi	15/12/2010	12	15/12/2011

ANNEX D
MEASUREMENT UNCERTAINTY

Radio Testing – General Uncertainty Schedule

All statements of uncertainty are expanded standard uncertainty using a coverage factor of 1.96 to give a 95% confidence where no required test level exists.

[1] Adjacent Channel Power

Uncertainty in test result = **1.86dB**

[2] Carrier Power

Uncertainty in test result (Equipment - TRACUH120) = **2.18dB**

Uncertainty in test result (Equipment – TRAC05) = **1.08dB**

Uncertainty in test result (Equipment – TRAC479) = **2.48dB**

[3] Effective Radiated Power

Uncertainty in test result = **4.71dB**

[4] Spurious Emissions

Uncertainty in test result = **4.75dB**

[5] Maximum frequency error

Uncertainty in test result (Equipment - TRACUH120) = **119ppm**

Uncertainty in test result (Equipment – TRAC05) = **0.113ppm**

Uncertainty in test result (Equipment – TRAC479) = **0.265ppm**

[6] Radiated Emissions, field strength OATS 14kHz-18GHz Electric Field

Uncertainty in test result (14kHz – 30MHz) = **4.8dB**, Uncertainty in test result (30MHz – 1GHz) = **4.6dB**,

Uncertainty in test result (1GHz-18GHz) = **4.7dB**

[7] Frequency deviation

Uncertainty in test result = **3.2%**

[8] Magnetic Field Emissions

Uncertainty in test result = **2.3dB**

[9] Conducted Spurious

Uncertainty in test result (Equipment TRAC479) Up to 8.1GHz = **3.31dB**

Uncertainty in test result (Equipment TRAC479) 8.1GHz – 15.3GHz = **4.43dB**

Uncertainty in test result (Equipment TRAC479) 15.3GHz – 21GHz = **5.34dB**

Uncertainty in test result (Equipment TRACUH120) Up to 26GHz = **3.14dB**

[10] Channel Bandwidth

Uncertainty in test result = **15.5%**

[11] Amplitude and Time Measurement – Oscilloscope

Uncertainty in overall test level = **2.1dB**, Uncertainty in time measurement = **0.59%**, Uncertainty in Amplitude measurement = **0.82%**

[12] Power Line Conduction

Uncertainty in test result = **3.4dB**

[13] Spectrum Mask Measurements

Uncertainty in test result = **2.59% (frequency)**
Uncertainty in test result = **1.32dB (amplitude)**

[14] Adjacent Sub Band Selectivity

Uncertainty in test result = **1.24dB**

[15] Receiver Blocking – Listen Mode, Radiated

Uncertainty in test result = **3.42dB**

[16] Receiver Blocking – Talk Mode, Radiated

Uncertainty in test result = **3.36dB**

[17] Receiver Blocking – Talk Mode, Conducted

Uncertainty in test result = **1.24dB**

[18] Receiver Threshold

Uncertainty in test result = **3.23dB**

[19] Transmission Time Measurement

Uncertainty in test result = **7.98%**