

Test Plan and Test Results

BS-240 BTS Base Station

FCC ID: NE3PCS007

Name of Applicant

*Siemens Information and Communication Networks, Inc.
900 Broken Sound Parkway
Boca Raton, FL 33487*

TABLE OF CONTENTS

1	EQUIPMENT UNDER TEST (EUT)	4
2	MEASUREMENTS	5
2.1	General description	5
2.2	Summary of the measurements	5
2.2.1	EUT configuration and operating conditions	5
2.2.2	Selected carrier test frequencies	6
2.2.3	Modulation characteristics	6
2.2.4	Measurement test configuration	7
2.2.5	Calibration of the measurement equipment	7
2.3	Test No. 1: RF power output (§ 2.1046)	8
2.3.1	Purpose	8
2.3.2	EUT operation condition	8
2.3.3	Test configuration	8
2.3.4	Measurement procedure	8
2.3.5	Measurement results	8
2.4	Test No. 2: Modulation characteristics (§ 2.1047, § 2.201)	9
2.5	Test No. 3: Occupied bandwidth (§ 2.1049)	10
2.5.1	Purpose	10
2.5.2	EUT operation condition	10
2.5.3	Test configuration	10
2.5.4	Measurement procedure and results	10
2.6	Test No. 4: Spurious emissions at antenna terminals (§ 2.1051, § 2.1057, § 22.917)	11
2.6.1	Purpose	11
2.6.2	Limits	11
2.6.3	EUT operation condition	11
2.6.4	Test configuration	11
2.6.5	Measurement procedure and results	11
2.7	Test No. 5: Field strength of spurious radiation (§ 2.1053, § 2.1057, § 22.917)	14
2.7.1	Purpose	14
2.7.2	Limits	14
2.7.3	EUT operation condition	14
2.7.4	Test configuration	14
2.7.5	Measurement procedure	15
2.7.6	Measurement results & limits	15
2.8	Test No. 6: Frequency stability (§ 2.1055, § 22.355)	16
2.8.1	Purpose	16
2.8.2	Limits	16
2.8.3	EUT operation condition	16
2.8.4	Test configuration	16
2.8.5	Measurement procedure	17
2.8.6	Measurement results	17
2.9	Test No. 7: Slow frequency hopping	18

2.9.1	Introduction	18
2.9.2	Purpose	18
2.9.3	EUT operation condition	18
2.9.4	Test configuration	18
2.9.5	Measurement procedure	18
2.9.6	Measurement results	18
3	MEASUREMENT DATA AND SPECTRAL PLOTS	20
3.1	Part list of the measurement test equipment	20
3.2	Spectral plots	21

1 Equipment under test (EUT)

The equipment under test (EUT) comprises the modules listed in the table below.

Module Name	Siemens Part No.	Serial No.
DUAMCO2850V1	S30861-U2296-X-01/01	KSA/N8112025
ECU850V2	S30861-U2302-X-E1/01	RX+/P1247328
ECU850V2	S30861-U2302-X-E1/01	RX+/P1247335

For a functional description of the modules, please refer to the appropriate related parts and exhibit sections of this certification application.

The tests were conducted with the modules installed in a BS-240XLU. Worst-case measurement data is reported.

The tested system was equipped as per Fig. 1 on page 7 with its maximum number of 12 transceivers. Although only one transceiver (EUT) was tested for compliance, the other transceivers were investigated to ensure that the worst case test condition/transceiver was measured.

To comply with the FCC rules the lowest and highest authorized channel frequencies are disabled and cannot be activated by the user. Refer to section IV of the “Certification Application Overview”, located in the cover letter section, for details on how the channels are disabled.

A complete description of the transceiver’s calibration/tuning procedure is included in the Parts List and TuneUp exhibit section of this application.

2 Measurements

2.1 General description

2.2 Summary of the measurements

The measurements described in the following sections were conducted pursuant to 47 CFR § 2.947. All applicable paragraphs of the 47 CFR parts 2 and 22 of the most current version of the rules were considered.

The measurements were performed at Siemens AG, Institute for Quality Engineering and Testing, Hofmannstr. 50, 81359 Munich, Germany.

The following tests were performed according to the FCC rules in order to verify the compliance of the EUT with the FCC requirements:

Test No.	Measurement	FCC Rule	Page Number of this Report	Results
1	RF power output	§ 2.1046	8	compliant
2	Modulation characteristics	§ 2.1047, § 2.201	9	compliant
3	Occupied bandwidth	§ 2.1049	10	compliant
4	Spurious emissions at antenna terminals	§ 2.1051, § 2.1057, § 22.917	11	compliant
5	Field strength of spurious radiation	§ 2.1053, § 2.1057, § 22.917	14	compliant
6	Frequency stability	§ 2.1055, § 22.355	16	compliant
7	Slow frequency hopping	N/A	18	compliant

In accordance with the FCC Rule §15.3 (z) the equipment was tested with the limits that are valid for an *unintentional radiator*.

2.2.1 EUT configuration and operating conditions

If not stated otherwise, the following standard setup procedure for the EUT under test was used:

A Protocol Tester K1297 is used to control the EUT. The K1297 is connected to the EUT via the A_{bis} Link. For detailed test system equipment configuration please refer to Fig. 1 on page 7.

The transmitter modules were tuned up according to the procedure described in the TuneUp exhibit section of this application.

During the measurements, one carrier channel was tested at a time. The carrier was set to the maximum power level with all timeslots activated to ensure the maximum emission amplitudes during all measurements.

A pseudo random bit pattern was applied to the digital modulator. This ensures that the measurements of the emission characteristics of the transmitter are pursuant to § 2.1049.

2.2.2 Selected carrier test frequencies

The measurements were performed at 3 selected carrier test frequencies, according to the following table:¹

Carrier Test Frequency [MHz]	Remark
869.4	lowest possible carrier frequency
881.6	frequency at the middle of the band
893.6	highest possible carrier frequency

2.2.3 Modulation characteristics

The EUT supports two types of modulation: GMSK and 8PSK. The modulation characteristic of the GMSK and the 8PSK modulation is defined in standard 3GPP TS 05.04.

During all measurements described below, a pseudo random sequence was applied to the digital modulator to ensure that the emission characteristics of the transmitter are pursuant to § 2.1049.

¹ The uppermost and lowermost channels of each frequency block are disabled in order to be compliant with the emission limit requirements of § 22.917. See section IV of the “Certification Application Overview”, located in the cover letter section, for details.

2.2.4 Measurement test configuration

If not stated otherwise, the following measurement configuration was used to perform all measurements (see figure below):

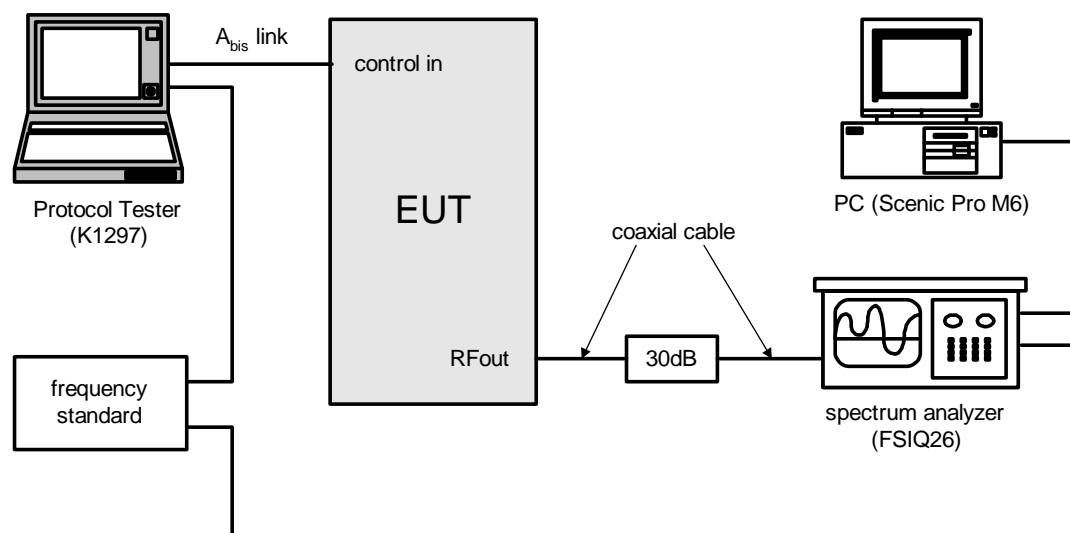

Fig. 1 – Measurement Test Configuration

The EUT is controlled by a protocol tester Tektronix K1297 via the serial Abis Link. The RF output signal is injected into a spectrum analyzer Rohde&Schwarz FSIQ26 via a high power 30 dB attenuator. The attenuator is used to protect the input of the spectrum analyzer from high RF power levels. All measurements of the analyzer are performed in peak detector (max hold) mode in order to ensure that the highest possible emission amplitudes of the EUT are captured by the measurement equipment. No video filtering was used throughout the measurements. A description of the analyzer settings is given in each of the sections describing the measurements. A complete list of the measurement equipment is included on page 20 of this measurement report.

2.2.5 Calibration of the measurement equipment

The spectrum analyzer has a built-in self-calibration procedure. This calibration procedure was activated prior to the measurements so that the analyzer is deemed accurate. The attenuation of the attenuator is within the manufacturer's specified limits. High quality cables were used to connect the measurement equipment to the EUT. The maximum loss of the cable is within the manufacturer's limits.

2.3 Test No. 1: RF power output (§ 2.1046)

2.3.1 Purpose

The RF power output measurements were performed pursuant to § 2.1046 in order to determine the peak rated RF output power of the EUT.

2.3.2 EUT operation condition

The EUT was configured and operating as described in section 2.2.1. The RF output power was determined at three selected carrier test frequencies according to section 2.2.2 of this application.

2.3.3 Test configuration

The test configuration used is described in the block diagram in section 2.2.4. See page 7 for a block diagram (Fig. 1).

2.3.4 Measurement procedure

The RBW setting of the spectrum analyzer was increased until the measured power reached a stable upper limit (RBW = 1MHz).

2.3.5 Measurement results

The following table shows the measured output powers at the RF output terminal. Spectral plots are included on pages 21 – 23 of this report.

Note:

The offset value indicated on the spectral plots represents the external attenuation value that includes the fixed attenuator plus the cable loss.

GMSK modulation

Carrier Test Frequency [MHz]	Indicated Power Level [dBm]	External Attenuation [dB]	RF Power	Results
869.4	15.1	32.0	47.1 dBm $\hat{=}$ 51.3 W	compliant
881.6	15.1	32.0	47.1 dBm $\hat{=}$ 51.3 W	compliant
893.6	15.1	32.0	47.1 dBm $\hat{=}$ 51.3 W	compliant

8PSK modulation

Carrier Test Frequency [MHz]	Indicated Power Level [dBm]	External Attenuation [dB]	RF Power	Results
869.4	15.3	32.0	47.3 dBm $\hat{=}$ 53.7 W	compliant
881.6	15.6	32.0	47.6 dBm $\hat{=}$ 57.5 W	compliant
893.6	15.6	32.0	47.6 dBm $\hat{=}$ 57.5 W	compliant

The measured power levels were found to be compliant with the manufacturer's specifications and with all requirements of the FCC rules.

2.4 Test No. 2: Modulation characteristics (§ 2.1047, § 2.201)

The occupied bandwidth was measured to be 253 kHz, which represents the 99% power bandwidth (refer to the spectral plots included on pages 25 – 27 and the following section). Three carrier test frequencies were investigated. Therefore, the modulation characteristic of the base stations transceiver is 253KGXW. No further testing measurements are required under this section of the rules.

No measurements are required here other than the occupied bandwidth.

The modulation characteristics were found to be compliant with the manufacturer's specifications and with all requirements of the FCC rules.

2.5 Test No. 3: Occupied bandwidth (§ 2.1049)

2.5.1 Purpose

The measurements are performed to determine the occupied bandwidth of the EUT pursuant to § 2.1049.

2.5.2 EUT operation condition

The EUT was set up according to section 2.2.1 of this test report. A pseudo random bit pattern was applied to the modulator. First the test transceiver was modulated using GMSK modulation. Afterwards the measurements were repeated with 8PSK modulation. For a specific modulation technique description, please see section XII of the “Certification Application Overview”, located in the cover letter section of this application. For circuit diagrams of the modulator, please refer to the Schematics exhibit section of this application.

2.5.3 Test configuration

The test configuration used is described in the block diagram in section 2.2.4. See page 7 for a block diagram (Fig. 1).

2.5.4 Measurement procedure and results

The occupied bandwidth was determined for each of the test frequencies listed in the table below. See the spectral plots included on pages 25 – 27 for details. The 99% power bandwidth was determined with the spectrum analyzer. The following table summarizes the measurement results:

GMSK modulation:

Carrier Test Frequency [MHz]	Occupied Bandwidth [kHz]	Results
869.4	244.5	compliant
881.6	244.5	compliant
893.6	244.5	compliant

8PSK modulation:

Carrier Test Frequency [MHz]	Occupied Bandwidth [kHz]	Results
869.4	252.5	compliant
881.6	248.5	compliant
893.6	248.5	compliant

The occupied bandwidth was found to be compliant with the manufacturer’s specifications and with all requirements of the FCC rules.

2.6 Test No. 4: Spurious emissions at antenna terminals (§ 2.1051, § 2.1057, § 22.917)

2.6.1 Purpose

The measurements of the spurious emissions at the equipment output terminals were performed pursuant to § 2.1051 in order to verify that any emissions are below the limits given by § 22.917 (e).

2.6.2 Limits

Compliance with § 22.917 (e) requires that any emission be attenuated below the transmitter power by at least $43 + 10 \log_{10} P$ (P = transmitter power in Watts).

The compliance limit was calculated as per the following table:

GMSK modulation:

Rated maximum transmitter output power	57.54 W (≈ 47.6 dBm)
Required attenuation	$43 + 10 \log_{10} 57.54 = 60.6$ dB
Rated maximum transmitter output power – required attenuation = compliance limit	47.6 dBm – 60.6 dB = –13 dBm

8PSK modulation:

Rated maximum transmitter output power	64.57 W (≈ 48.1 dBm)
Required attenuation	$43 + 10 \log_{10} 64.57 = 61.1$ dB
Rated maximum transmitter output power – required attenuation = compliance limit	48.1 dBm – 61.1 dB = –13 dBm

2.6.3 EUT operation condition

The standard setup procedure as described in section 2.2.1 of this report was used.

2.6.4 Test configuration

The test configuration used is described in the block diagram in section 2.2.4. See page 7 for a block diagram (Fig. 1).

2.6.5 Measurement procedure and results

In accordance with § 22.917 (h), a 30 kHz resolution bandwidth was used for the measurements. The measurements were performed at all 3 selected carrier test frequencies. Refer to section 2.2.2 of this test report. According to § 2.1057, all emission including the fundamental frequency of the transceiver and all frequencies up to the 10th harmonic were investigated.

The following table summarizes the worst case detected emission levels (refer to spectral plots included on pages 28 – 36 for details):

Note:

The offset value indicated on the spectral plots represents the external attenuation value that includes the fixed attenuator plus the cable loss.

GMSK modulation:

Frequency Marker Indication [MHz]	Indicated Power Level [dBm]	External Attn. [dB]	Worst Case Emission Level [dBm]	Compliance Limit [dBm]	Spectral Plot on Page:	Results
Carrier Test Frequency 869.4 MHz						
669.2	-72.1	32.0	-40.1	-13.0	28	compliant
1733.3	-54.8	32.0	-22.8	-13.0	29	compliant
2647.0	-58.4	32.0	-26.4	-13.0	29	compliant
6623.2	-67.2	32.0	-35.2	-13.0	30	compliant
Carrier Test Frequency 881.6 MHz						
681.4	-73.8	32.0	-41.8	-13.0	31	compliant
1758.0	-57.4	32.0	-25.4	-13.0	32	compliant
2606.0	-59.0	32.0	-27.0	-13.0	32	compliant
6603.2	-68.3	32.0	-36.3	-13.0	33	compliant
Carrier Test Frequency 893.6 MHz						
693.5	-72.0	32.0	-40.0	-13.0	34	compliant
1783.0	-64.3	32.0	-32.3	-13.0	35	compliant
2679.5	-57.4	32.0	-25.4	-13.0	35	compliant
6653.3	-66.9	32.0	-34.9	-13.0	36	compliant

Note:

The offset value indicated on the spectral plots represents the external attenuation value that includes the fixed attenuator plus the cable loss.

8PSK modulation:

Frequency Marker Indication [MHz]	Indicated Power Level [dBm]	External Attn. [dB]	Worst Case Emission Level [dBm]	Compliance Limit [dBm]	Spectral Plot on Page:	Results
Carrier Test Frequency 869.4 MHz						
862.1	-71.4	32.0	-39.4	-13.0	28	compliant
1733.3	-58.8	32.0	-26.8	-13.0	29	compliant
2646.6	-61.4	32.0	-29.4	-13.0	29	compliant
6613.2	-66.7	32.0	-34.7	-13.0	30	compliant
Carrier Test Frequency 881.6 MHz						
763.0	-72.6	32.0	-40.6	-13.0	31	compliant
1758.0	-58.1	32.0	-26.1	-13.0	32	compliant
2605.5	-65.7	32.0	-33.7	-13.0	32	compliant
6593.2	-66.7	32.0	-34.7	-13.0	33	compliant
Carrier Test Frequency 893.6 MHz						
693.5	-72.6	32.0	-40.6	-13.0	34	compliant
1782.7	-65.1	32.0	-33.1	-13.0	35	compliant
2679.6	-61.0	32.0	-29.0	-13.0	35	compliant
6613.2	-66.7	32.0	-34.7	-13.0	36	compliant

The measured conducted emission levels were found to be compliant with the manufacturer's specifications and with all requirements of the FCC rules.

2.7 Test No. 5: Field strength of spurious radiation (§ 2.1053, § 2.1057, § 22.917)

2.7.1 Purpose

The measurement of spurious radiated emissions was performed pursuant to § 2.1053 and § 2.1057 to verify that the field strength of any spurious emissions radiated directly from the cabinet, control circuits, power leads or intermediate circuit elements are attenuated below the transmitter power P by at least $43 + 10 \log_{10} (P \text{ in Watts})$ dB as is required by § 22.917 (e) (Emission limitations).

2.7.2 Limits

Compliance with § 22.917 (e) requires that all spurious emissions be attenuated below the transmitter power by at least $43 + 10 \log_{10} P$ (P = rated maximum transmitter output power in Watts).

The compliance limit was calculated as per the following table:

GMSK modulation:

Rated maximum transmitter output power	57.54 W (≈ 47.6 dBm)
Required attenuation	$43 + 10 \log_{10} 57.54 = 60.6$ dB
Rated maximum transmitter output power – required attenuation = compliance limit	47.6 dBm – 60.6 dB = –13 dBm

8PSK modulation:

Rated maximum transmitter output power	64.57 W (≈ 48.1 dBm)
Required attenuation	$43 + 10 \log_{10} 64.57 = 61.1$ dB
Rated maximum transmitter output power – required attenuation = compliance limit	48.1 dBm – 61.1 dB = –13 dBm

According to § 2.1057, all emissions to the 10th harmonic were investigated.

2.7.3 EUT operation condition

The EUT was configured and operating as described in section 2.2.1. The radiated spurious emissions were determined for three selected carrier test frequencies, according to section 2.2.2. During all testing, the EUT’s RF output power was terminated into a 50 Ω dummy load.

2.7.4 Test configuration

The measurements (scans) were conducted for BS-240XLU. The measurements were performed in the anechoic chamber at the Siemens AG EMC Center, Hofmannstraße 51, 81359 Munich, Germany. The radiated test site complies with the site attenuation requirements listed in ANSI C63.4 1992 and is listed with the FCC.

The test antenna was positioned at a distance of 3 m from the EUT. Photographs of the EUT in the anechoic chamber are shown on page 37 of this measurement report.

2.7.5 Measurement procedure

The EUT was rotated 360°. The antenna height was adjusted between 1 m and 4 m. Both, horizontal and vertical polarizations were investigated.

To verify that all spurious emissions are compliant to the limits specified in § 22.917, the substitution method described in the ANSI/TIA/EIA-603-1992 document was used. Therefore the EUT has to be replaced by a signal generator and a dipole antenna to determine the power levels that are necessary to reproduce the field strength levels of the spurious emissions. These power levels have to be compared to the power output of the transmitter.

2.7.6 Measurement results & limits

Worst case detected emission levels are reported in the following table (refer to spectral plots included on pages 38 – 41 for details). The antenna factor and cable loss is according to the manufacturer’s specification.

GMSK modulation:

Frequency [MHz]	Field Strength [dBµV/m]	Power Signalgenerator [dBm]	Gain dipole + Cable Loss [dB]	Power calculated on the dipole [dBm]	Limit [dBm]	Results
3858.7	70.94	-30.7	8.97	-21.73	-13	compliant
5797.6	61.30	-42.0	10.75	-31.25	-13	compliant
7736.5	75.28	-30.5	11.70	-18.80	-13	compliant
9622.0	57.57	-48.5	12.35	-36.15	-13	compliant
11596.4	62.32	-44.8	13.25	-31.55	-13	compliant

8PSK modulation:

Frequency [MHz]	Field Strength [dBµV/m]	Power Signalgenerator [dBm]	Gain dipole + Cable Loss [dB]	Power calculated on the dipole [dBm]	Limit [dBm]	Results
3858.7	70.53	-31.0	8.97	-22.03	-13	compliant
7736.5	76.37	-29.0	11.70	-18.20	-13	compliant
7843.2	59.09	-43.8	11.70	-32.10	-13	compliant
7967.7	62.94	-42.4	11.70	-30.70	-13	compliant
11596.4	65.50	-41.8	13.25	-28.55	-13	compliant

The measured emission levels were found to be compliant with the manufacturer’s specifications and with all requirements of the FCC rules.

2.8 Test No. 6: Frequency stability (§ 2.1055, § 22.355)

2.8.1 Purpose

Frequency stability measurements were performed to verify that the frequency deviation of the emission stays within the licensee’s frequency block under extreme temperature conditions (-30°C to +50°C) according to § 2.1055.

2.8.2 Limits

According to § 22.355, the frequency tolerance of the carrier frequency of a base station (frequency range 821-896 MHz) must not exceed 1.5 ppm, independent of the ambient temperature.

2.8.3 EUT operation condition

The standard setup procedure as described in section 2.2.1 of this report is used. The EUT was operated and tested in a climatic chamber.

2.8.4 Test configuration

The EUT was controlled by a protocol tester Tektronix K1297 via the serial Abis Link. The RF output signal is injected into a mobile communication tester Rohde&Schwarz CMU300 via a high power 20 dB attenuator. The attenuator is used to protect the input of the measurement equipment from high RF power levels. A complete list of the measurement equipment is included on page 20 of this measurement report.

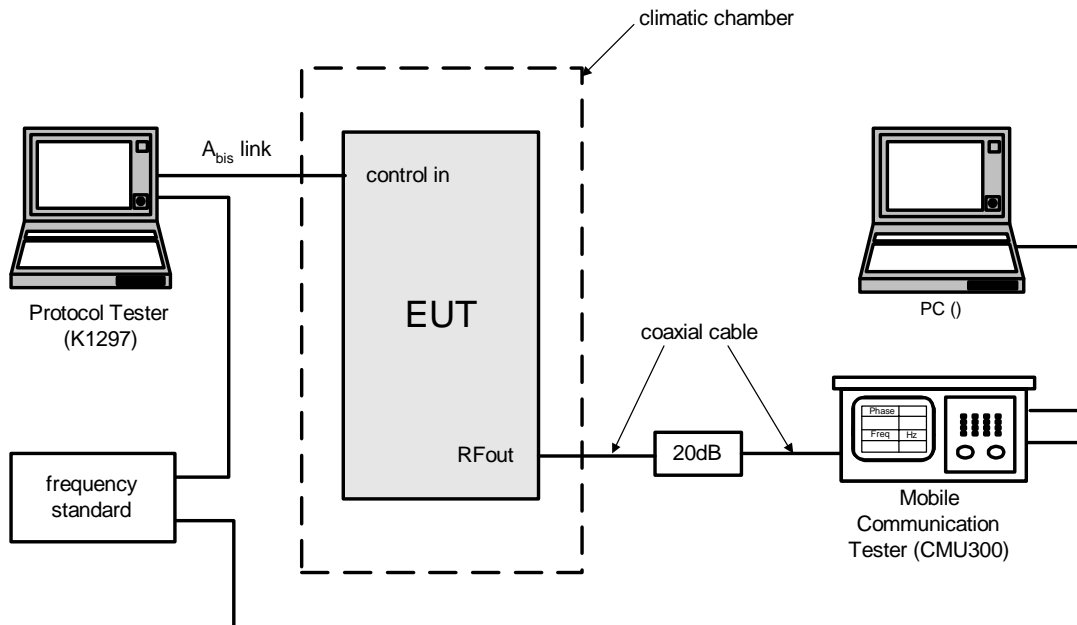

Fig. 2 – Measurement Test Configuration

2.8.5 Measurement procedure

The center frequency deviation of the highest and lowest test frequency was measured at ambient temperature levels from -5°C to +50°C in intervals of not more than 10°C.

At each temperature level, the frequency was measured over a time period of 10 minutes, taking one measurement value every minute.

2.8.6 Measurement results

The following table includes the worst case detected frequency deviations. For complete measurement data see plots on pages 42 – 43. The BS-240XLU is designed for indoor locations. Therefore the EUT does not work below a temperature of -5°C, no RF signals were measured at the antenna port.

GMSK modulation:

Ambient Temp. [°C]	Frequency Deviation @ - 48V	Limit	Results
-5	-0.015 ppm	1.5 ppm	compliant
+5	-0.015 ppm	1.5 ppm	compliant
+15	-0.015 ppm	1.5 ppm	compliant
+25	-0.017 ppm	1.5 ppm	compliant
+35	-0.013 ppm	1.5 ppm	compliant
+45	-0.014 ppm	1.5 ppm	compliant
+50	-0.013 ppm	1.5 ppm	compliant

8PSK modulation:

Ambient Temp. [°C]	Frequency Deviation @ - 48V	Limit	Results
-5	-0.025 ppm	1.5 ppm	compliant
+5	-0.026 ppm	1.5 ppm	compliant
+15	-0.024 ppm	1.5 ppm	compliant
+25	0.021 ppm	1.5 ppm	compliant
+35	-0.023 ppm	1.5 ppm	compliant
+45	0.015 ppm	1.5 ppm	compliant
+50	0 018 ppm	1.5 ppm	compliant

A pseudo random bit sequence was applied to the modulator during all testing. No variation of the frequency deviation due to keying was observed. Also, no variation of the frequency deviation due to the EUT's heater element was observed at any temperature level (refer to measurement data above).

The measured frequency stability was found to be compliant with the manufacturer's specifications and with all requirements of the FCC rules.

2.9 Test No. 7: Slow frequency hopping

2.9.1 Introduction

Slow frequency hopping (SFH) is a feature of GSM transceiver systems used to improve the signal quality under fading conditions. When SFH is activated, the carrier frequency is shifted to a different value on a timeslot per timeslot basis. This is depicted in the figure below (carrier test frequencies 869.4 MHz, 881.6 MHz, and 893.6 MHz).

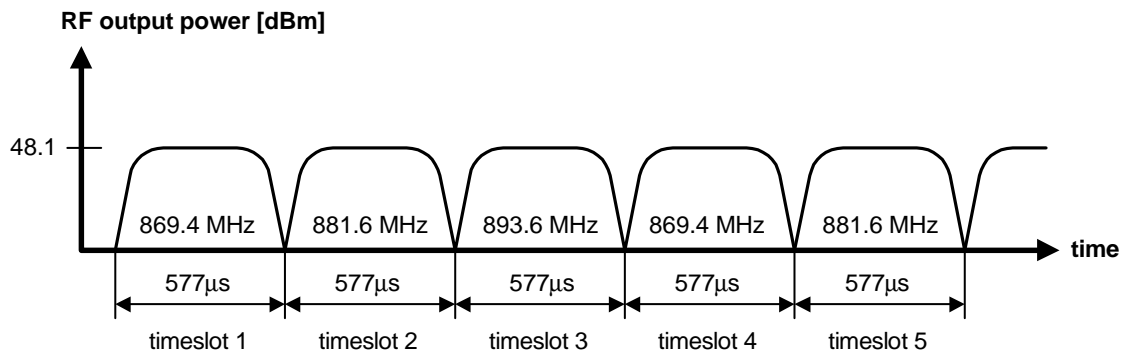

Fig. 3 – Slow frequency hopping (SFH) comprising 3 carrier test frequencies (869.4 MHz, 881.6 MHz, and 893.6 MHz).

SFH allows only one carrier per transmitter being activated at a time. This ensures that no intermodulation products are produced.

2.9.2 Purpose

These measurements were performed to verify that under SFH operating conditions, spurious emissions due to intermodulation products and periodically shifting the carrier frequency were not produced above the compliance level required under § 2.1051 of the FCC rules.

2.9.3 EUT operation condition

The EUT was configured and operating in a typical operation mode as described in section 2.2.1. The SFH operating mode was switched on throughout the measurements. 3 hopping test frequencies were measured in accordance with section 2.2.2 of this application. Please refer to Fig. 3 for the hopping scheme.

2.9.4 Test configuration

A test configuration was as described in section 2.2.4 of this application. See page 7 for a block diagram (Fig. 1).

2.9.5 Measurement procedure

A spectrum analyzer model Rohde&Schwarz FSIQ 26 was used to verify that all emissions are below the permissible limit.

2.9.6 Measurement results

SFH did not cause any detectable emissions above the compliance limits required by the FCC rules. The following table summarizes the worst case detected emission levels.

Note:

The offset value indicated on the spectral plots represents the external attenuation value that includes the fixed attenuator plus the cable loss.

GMSK modulation:

Frequency [MHz]	Indicated Power Level [dBm]	External Attenuation [dB]	Measured Power Level [dBm]	Compliance Limit [dBm]	Results
810.8	-49.5	32.0	-17.5	-13.0	compliant
848.4	-53.8	32.0	-21.8	-13.0	compliant
853.7	-53.9	32.0	-21.9	-13.0	compliant
906.7	-50.4	32.0	-18.4	-13.0	compliant
936.3	-54.2	32.0	-22.2	-13.0	compliant
964.8	-49.0	32.0	-17.0	-13.0	compliant

8PSK modulation:

Frequency [MHz]	Indicated Power Level [dBm]	External Attenuation [dB]	Measured Power Level [dBm]	Compliance Limit [dBm]	Results
850.5	-49.1	32.0	-17.1	-13.0	compliant
852.9	-52.8	32.0	-20.8	-13.0	compliant
875.4	-53.2	32.0	-21.2	-13.0	compliant
887.8	-48.5	32.0	-16.5	-13.0	compliant
913.1	-53.5	32.0	-21.5	-13.0	compliant
916.7	-49.2	32.0	-17.2	-13.0	compliant

The above listed emission levels were taken from measurements conducted using three different RBW (resolution bandwidth) settings (1 MHz, 300 kHz, and 3 kHz). The MaxHold mode of the spectrum analyzer was activated to capture worst case emission levels. Copies of the spectral plots can be found on pages 44 – 47.

It was verified through measurements that SFH does not cause any adverse effects on other parameters of the transmitter (RF power output, modulation characteristics, occupied bandwidth, spurious emissions, and frequency stability).

The measurement values were found to be compliant with the manufacturer’s specifications and with all requirements of the FCC rules.

3 Measurement data and spectral plots

3.1 Part list of the measurement test equipment

No.	Item	Model	Serial Number
1	Personal computer	Fujitsu Siemens SCENIC PRO M6	VKO25345
2	Personal computer	Fujitsu Siemens Lifebook	YBPJ015303
3	Spectrum analyzer	Rohde & Schwarz FSIQ 26	825556 / 005
4	Mobile Communication Tester	Rohde & Schwarz CMU300	100060
5	Mobile Communication Tester	Rohde & Schwarz CMU300	100059
6	Protocol Tester	Tektronix K1297	DE9908-2613
7	Protocol Tester	Tektronix K1297	DE0009-0274
8	Atomic clock reference	Datum GmbH RubiSource 2000	150
9	Atomic clock reference	Datum GmbH MRT Telecom	3768 / 002
10	Antenna	EMCO 3105	2025
11	Antenna	SING 94592-1	0118-04079
12	Antenna	Chase CBL6111	1566
13	Antenna	AILTE 96001	2622
14	Antenna	SCIEN 12-18	100
15	Controller	DEISE HD100	100/508
16	ESMI display section	Rohde & Schwarz ESMI	849182/009
17	ESMI RF section	Rohde & Schwarz ESMI	849937/003
18	Mast	DEISE MA240	240/445

3.2 Spectral plots

Test No. 1: RF Power Output (Carrier Test Frequency = 869.4 MHz)

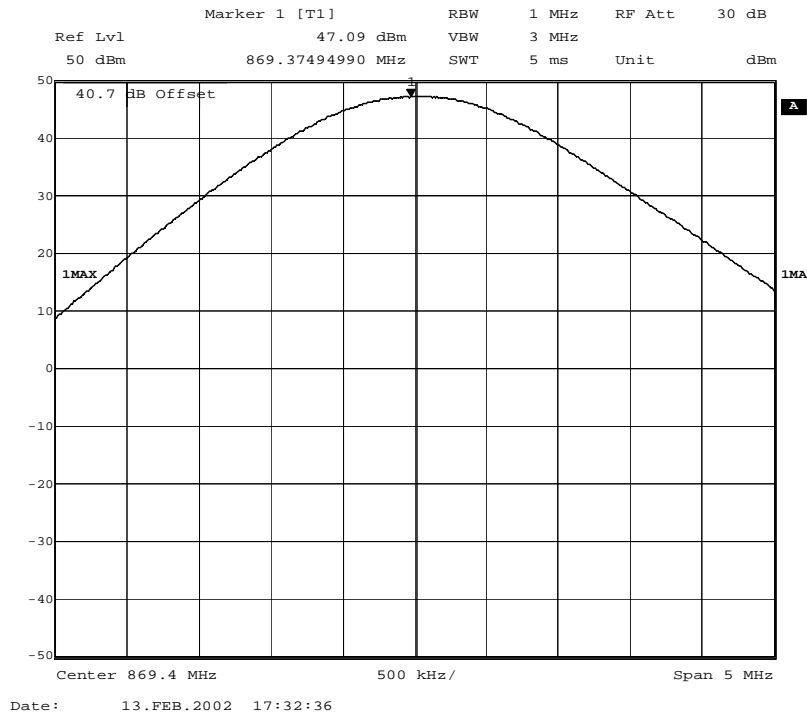

Fig. 4 – RF power at the antenna connector (GMSK modulation).

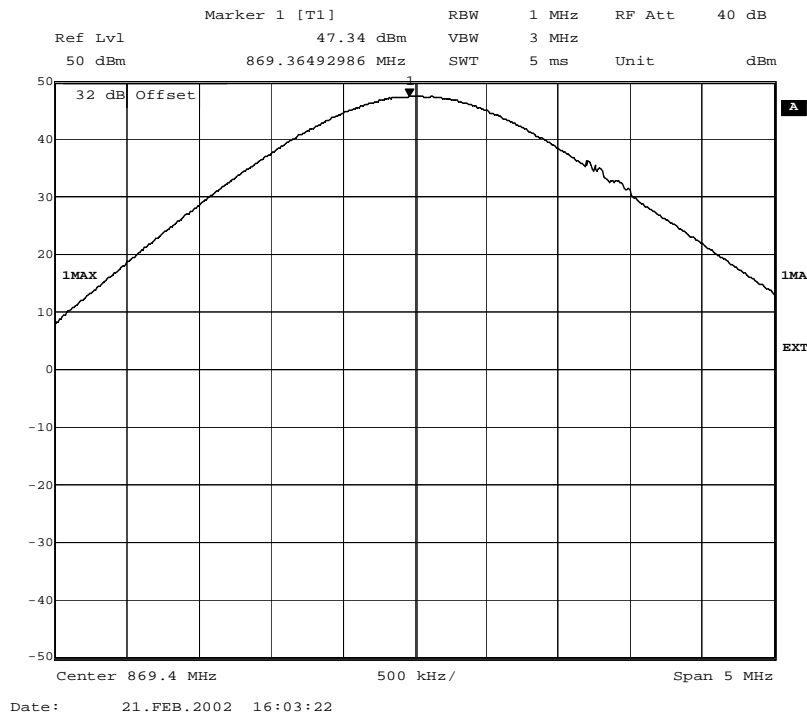

Fig. 5 – RF power at the antenna connector (8PSK modulation).

Note: The external attenuation of 32 dB is included in the spectral plot. This accounts for the external attenuator and the cable loss during the testing.

Test No. 1: RF Power Output (Carrier Test Frequency = 881.6 MHz)

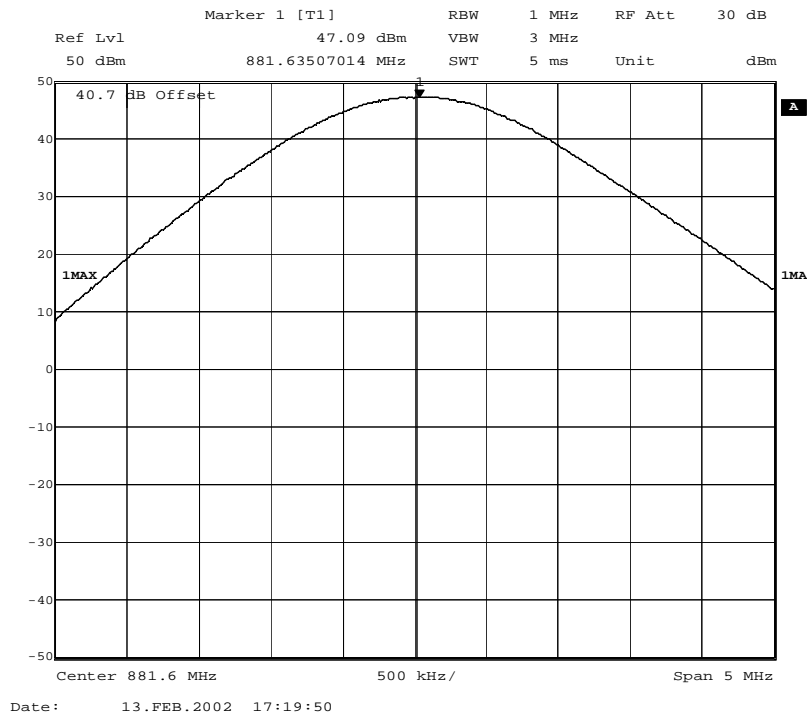

Fig. 6 – RF power at the antenna connector (GMSK modulation).

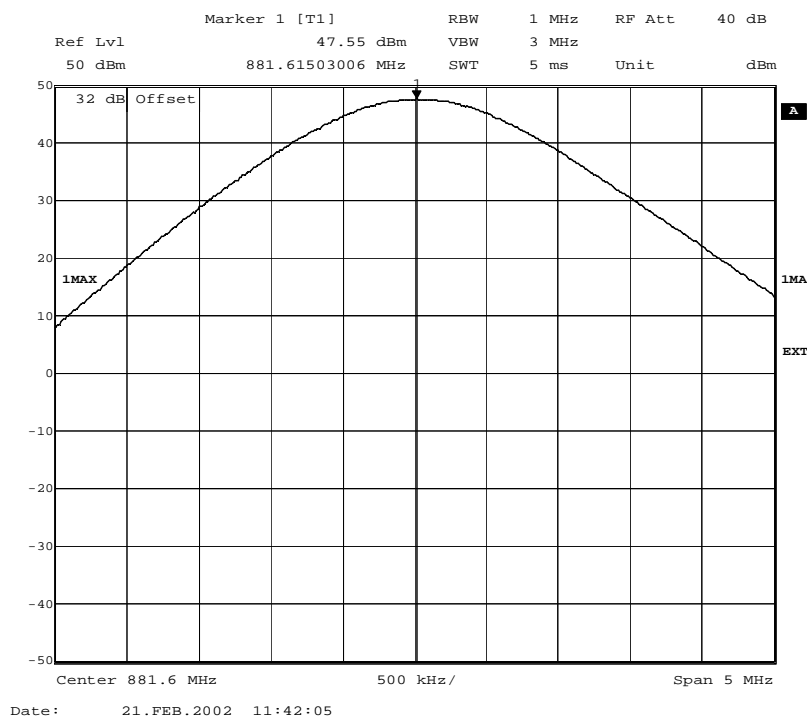

Fig. 7 – RF power at the antenna connector (8PSK modulation).

Note: The external attenuation of 32 dB is included in the spectral plot. This accounts for the external attenuator and the cable loss during the testing.

Test No. 1: RF Power Output (Carrier Test Frequency = 893.6 MHz)

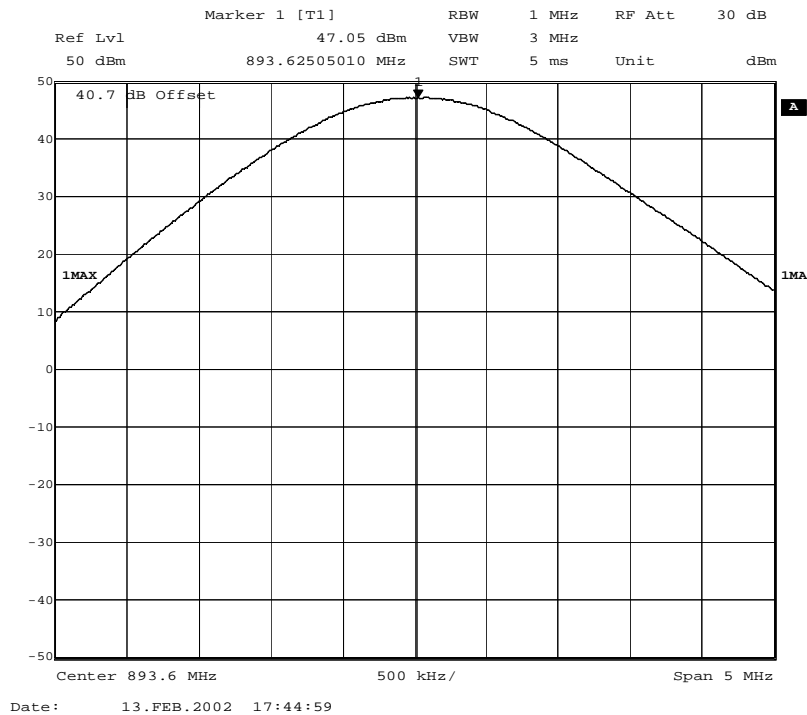

Fig. 8 – RF power at the antenna connector (GMSK modulation).

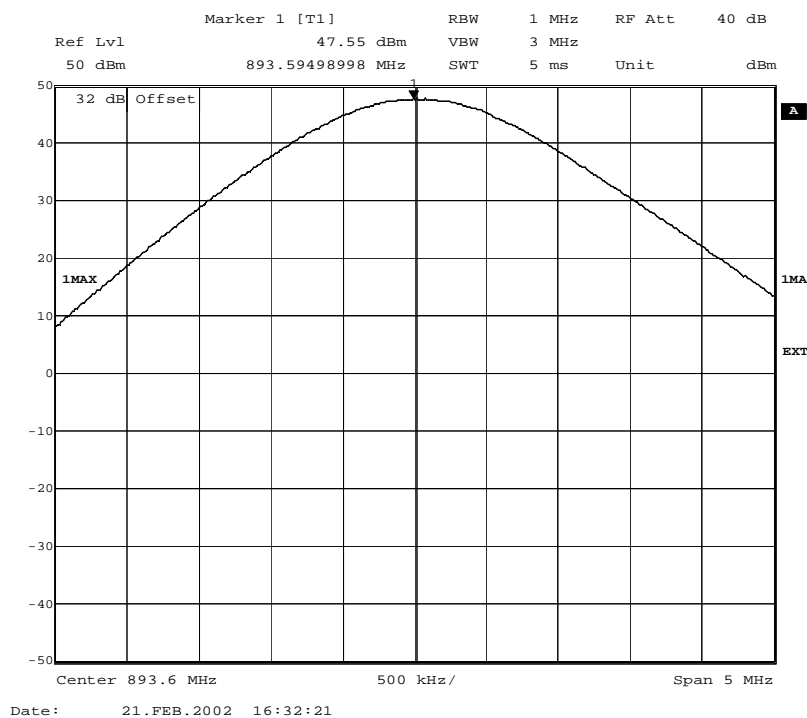

Fig. 9 – RF power at the antenna connector (8PSK modulation).

Note: The external attenuation of 32 dB is included in the spectral plot. This accounts for the external attenuator and the cable loss during the testing.

Test No. 2: Modulation Characteristics

No additional measurements are required for the modulation characteristics. Please refer to test no. 3, occupied bandwidth on page 10.

Test No. 3: Occupied Bandwidth (Carrier Test Frequency = 869.4 MHz)

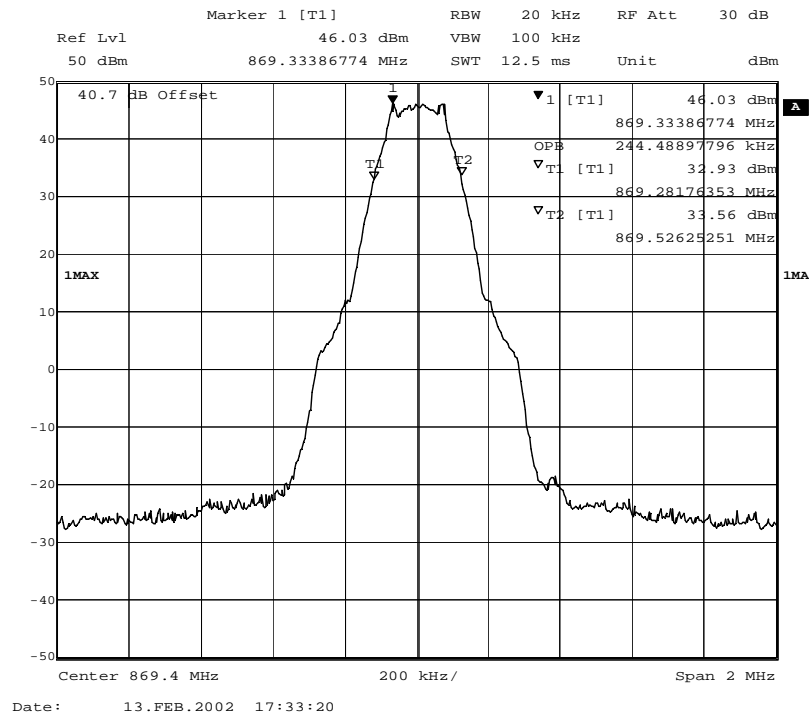

Fig. 10 – Occupied bandwidth (GMSK modulation).

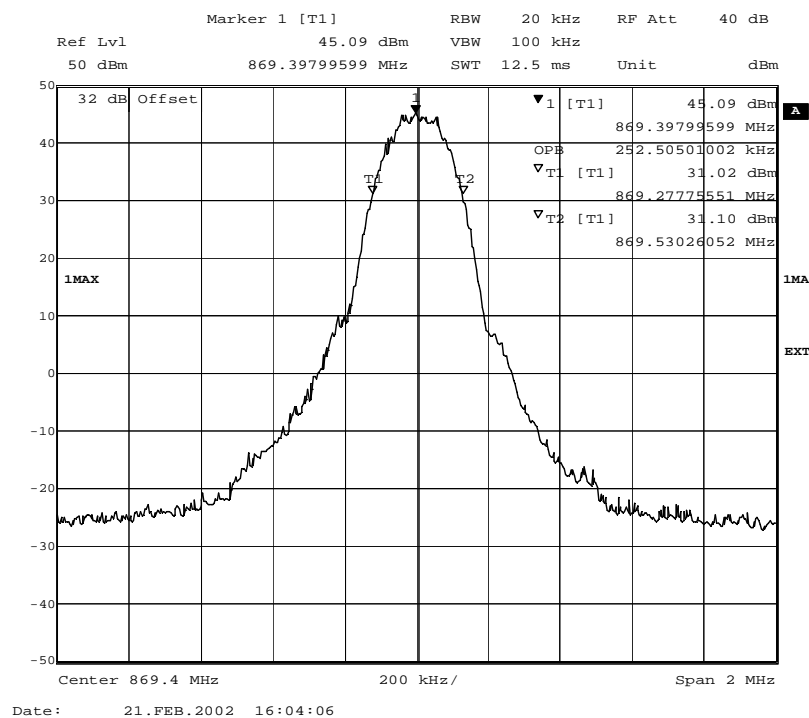

Fig. 11 – Occupied bandwidth (8PSK modulation).

Note: The external attenuation of 32 dB is included in the spectral plot. This accounts for the external attenuator and the cable loss during the testing.

Test No. 3: Occupied Bandwidth (Carrier Test Frequency = 881.6 MHz)

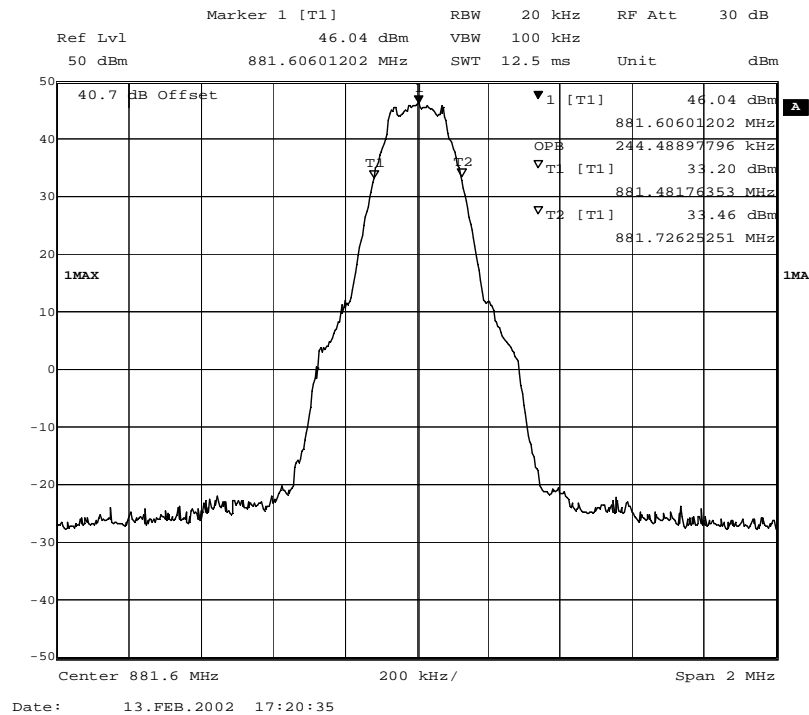

Fig. 12 – Occupied bandwidth (GMSK modulation).

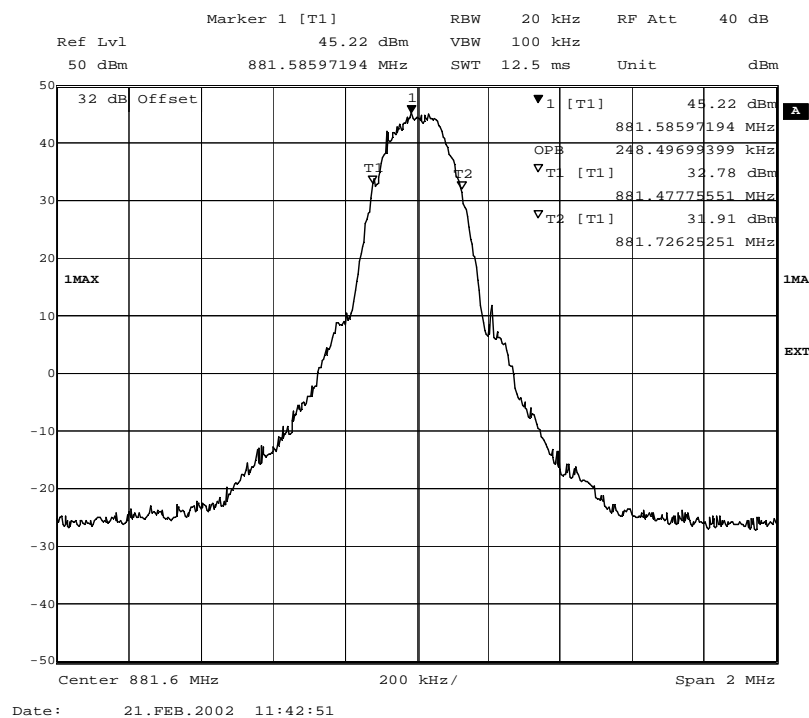

Fig. 13 – Occupied bandwidth (8PSK modulation).

Note: The external attenuation of 32 dB is included in the spectral plot. This accounts for the external attenuator and the cable loss during the testing.

Test No. 3: Occupied Bandwidth (Carrier Test Frequency = 893.6 MHz)

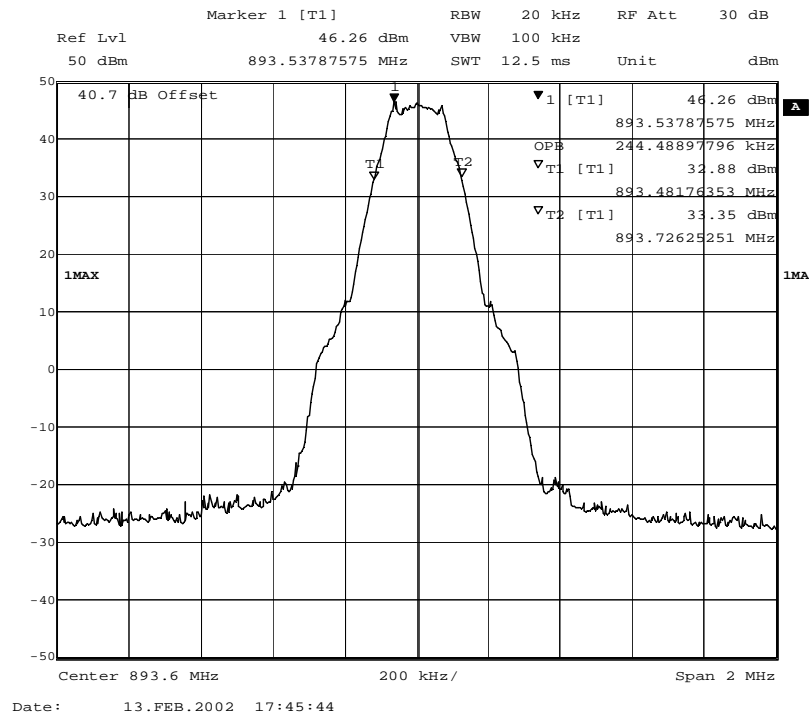

Fig. 14 – Occupied bandwidth (GMSK modulation).

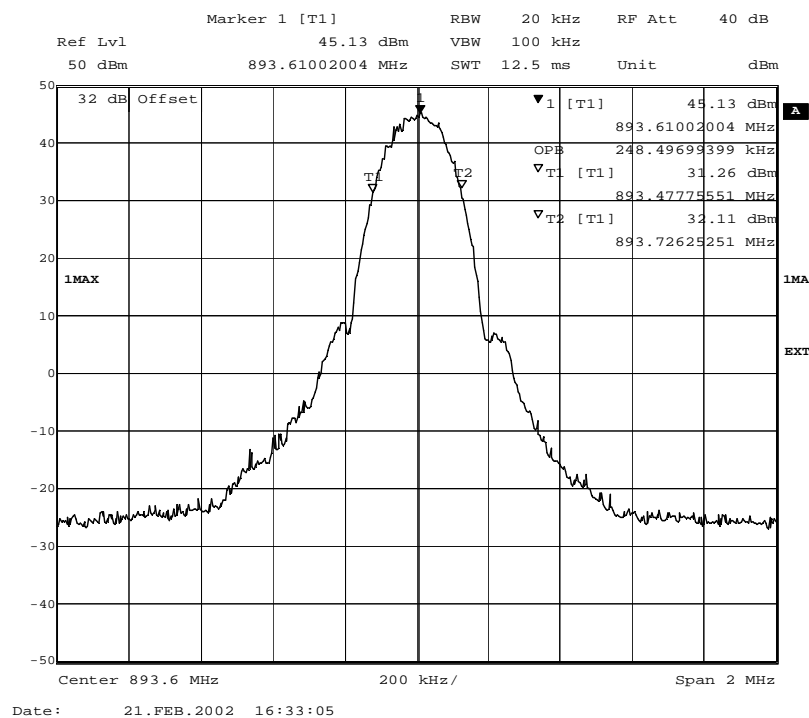

Fig. 15 – Occupied bandwidth (8PSK modulation).

Note: The external attenuation of 32 dB is included in the spectral plot. This accounts for the external attenuator and the cable loss during the testing.

**Test No. 4: Spurious Emissions at the Antenna Terminals
(Carrier Test Frequency = 869.4 MHz)**

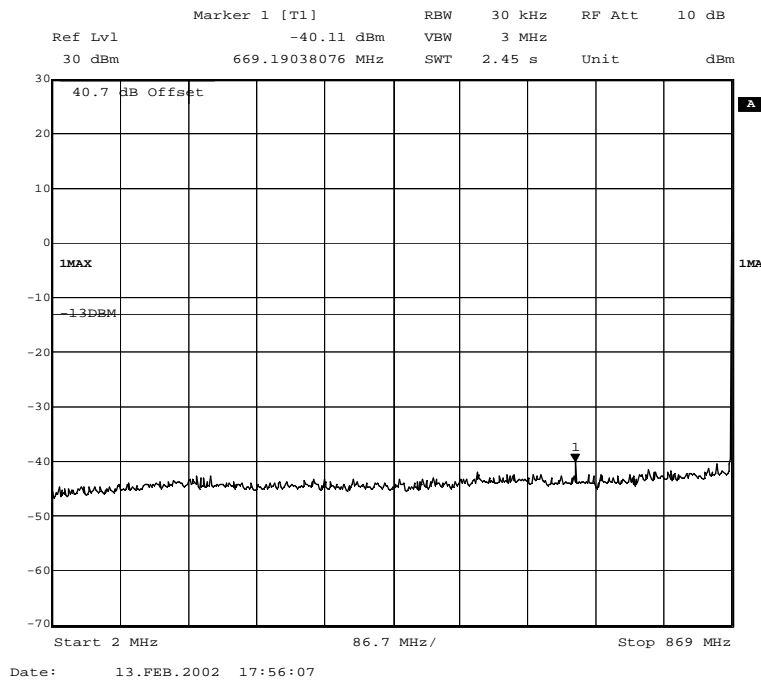

Fig. 16 – Spurious emissions in the frequency range 2 MHz – 869 MHz (GMSK modulation).

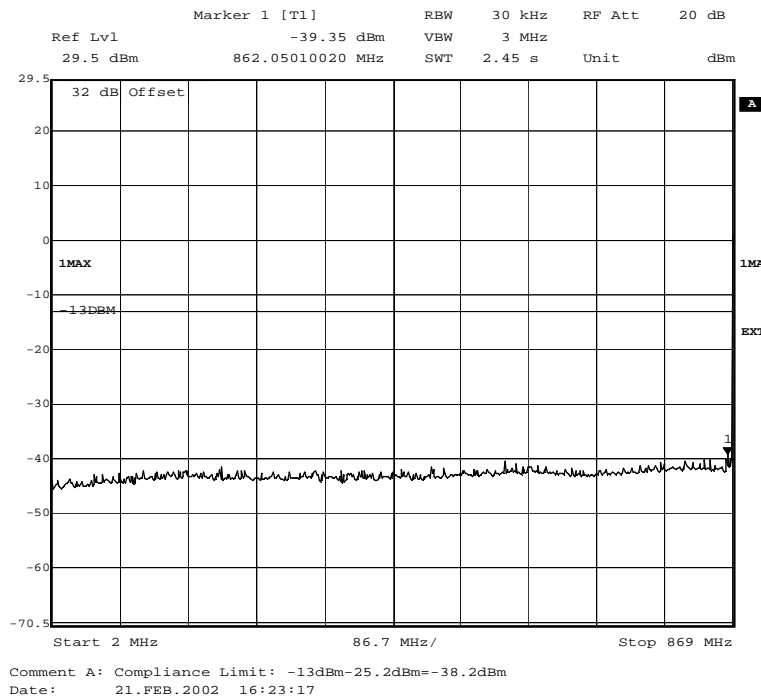

Fig. 17 – Spurious emissions in the frequency range 2 MHz – 869 MHz (8PSK modulation).

Note: The external attenuation of 32 dB is included in the spectral plot. This accounts for the external attenuator and the cable loss during the testing.

**Test No. 4: Spurious Emissions at the Antenna Terminals
(Carrier Test Frequency = 869.4 MHz)**

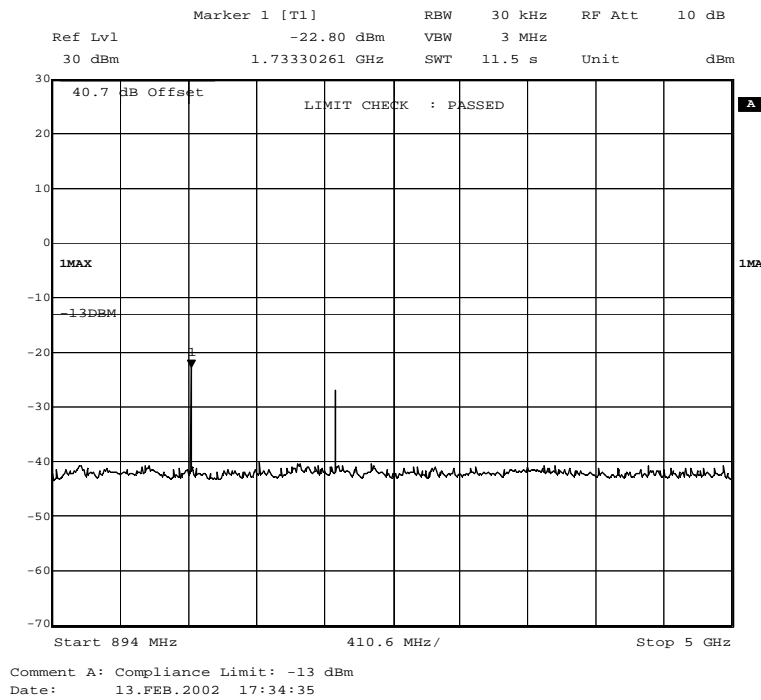

Fig. 18 – Spurious emissions in the frequency range 894 MHz – 5000 MHz (GMSK modulation).

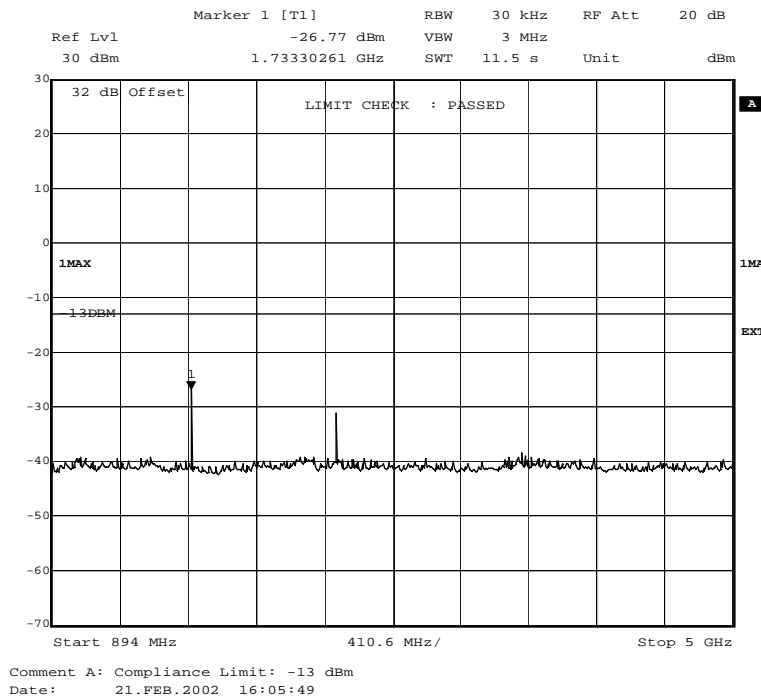

Fig. 19 – Spurious emissions in the frequency range 894 MHz – 5000 MHz (8PSK modulation).

Note: The external attenuation of 32 dB is included in the spectral plot. This accounts for the external attenuator and the cable loss during the testing.

**Test No. 4: Spurious Emissions at the Antenna Terminals
(Carrier Test Frequency = 869.4 MHz)**

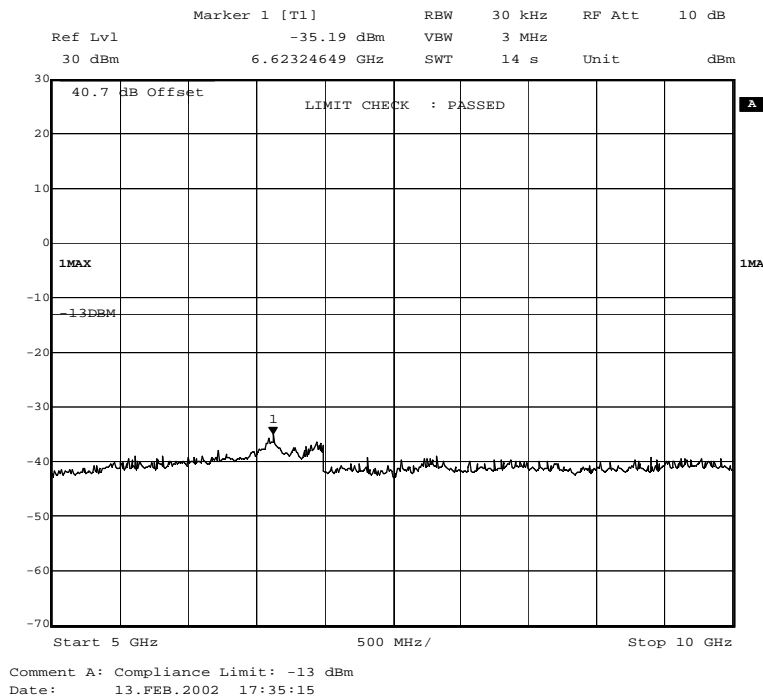

Fig. 20 – Spurious emissions in the frequency range 5000 MHz–10000 MHz (GMSK modulation).

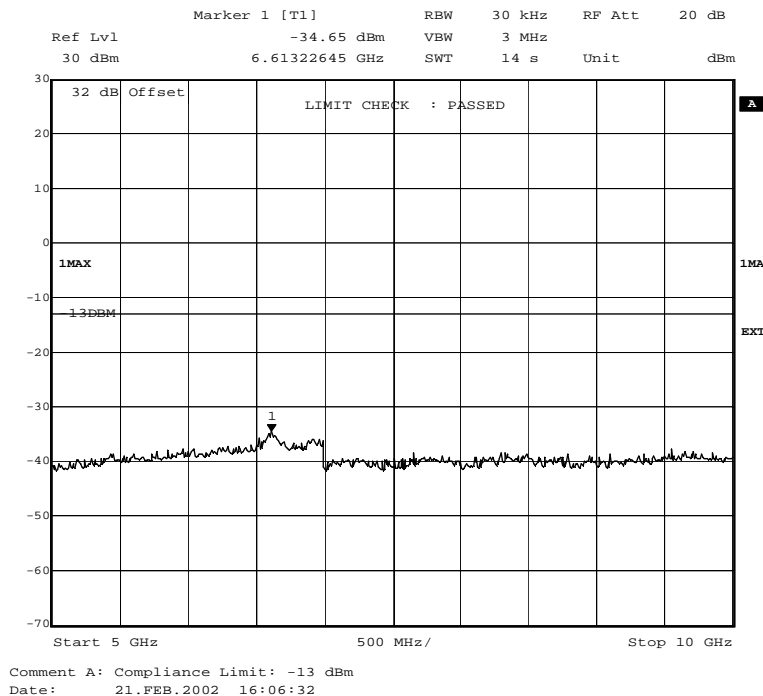

Fig. 21 – Spurious emissions in the frequency range 5000 MHz–10000 MHz (8PSK modulation).

Note: The external attenuation of 32 dB is included in the spectral plot. This accounts for the external attenuator and the cable loss during the testing.

**Test No. 4: Spurious Emissions at the Antenna Terminals
(Carrier Test Frequency = 881.6 MHz)**

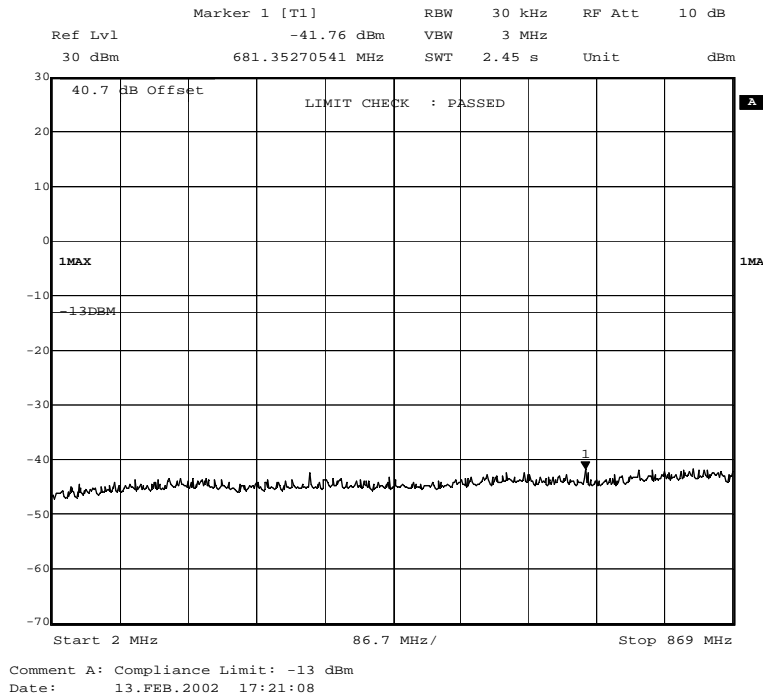

Fig. 22 – Spurious emissions in the frequency range 2 MHz – 869 MHz (GMSK modulation).

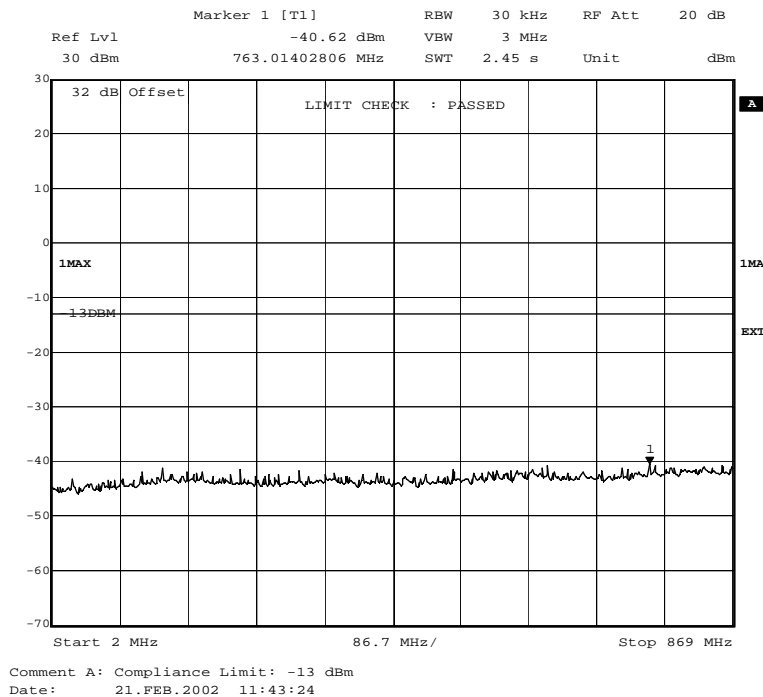

Fig. 23 – Spurious emissions in the frequency range 2 MHz – 869 MHz (8PSK modulation).

Note: The external attenuation of 32 dB is included in the spectral plot. This accounts for the external attenuator and the cable loss during the testing.

**Test No. 4: Spurious Emissions at the Antenna Terminals
(Carrier Test Frequency = 881.6 MHz)**

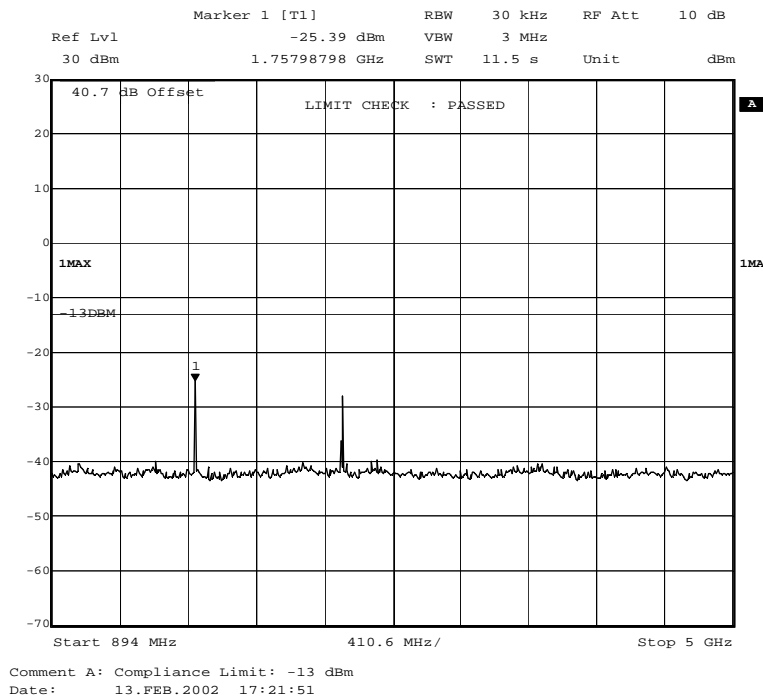

Fig. 24 – Spurious emissions in the frequency range 894 MHz – 5000 MHz (GMSK modulation).

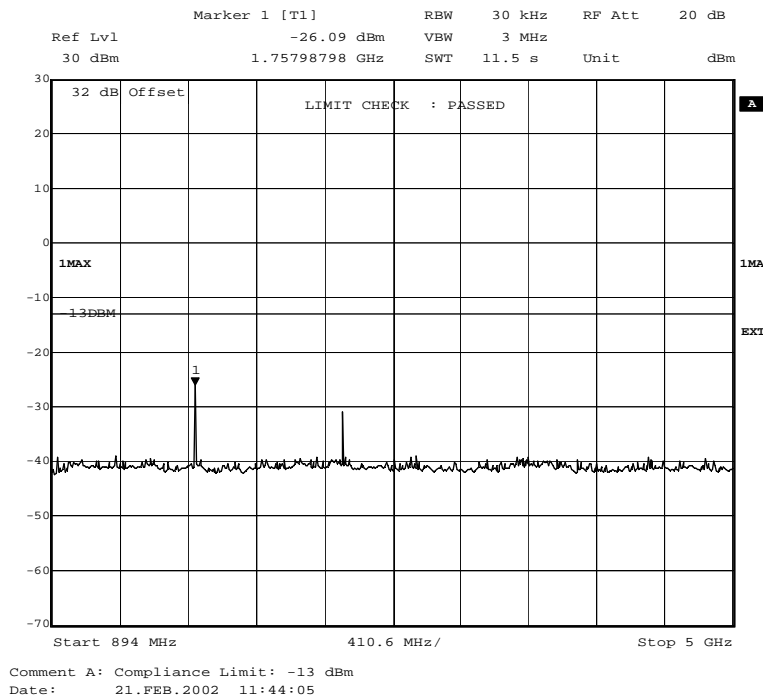

Fig. 25 – Spurious emissions in the frequency range 894 MHz – 5000 MHz (8PSK modulation).

Note: The external attenuation of 32 dB is included in the spectral plot. This accounts for the external attenuator and the cable loss during the testing.

**Test No. 4: Spurious Emissions at the Antenna Terminals
(Carrier Test Frequency = 881.6 MHz)**

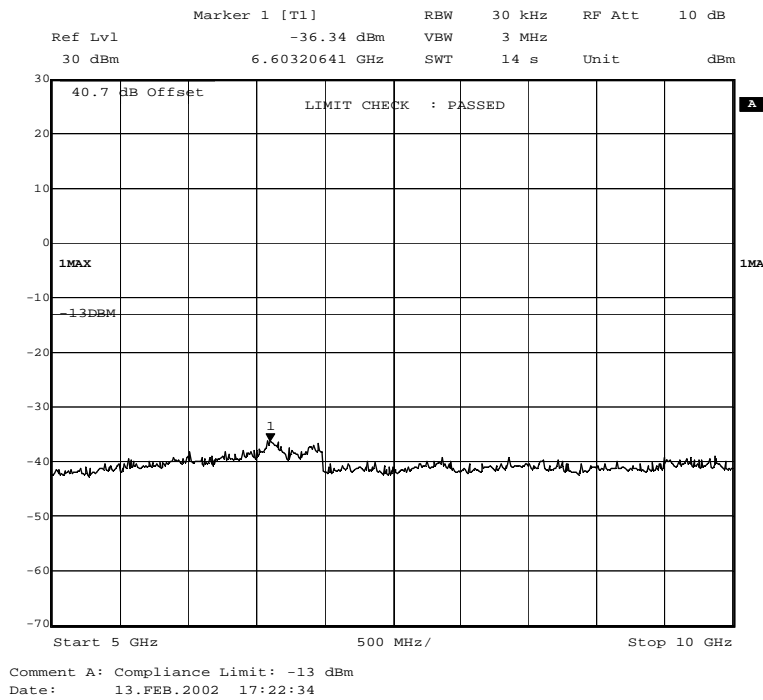

Fig. 26 – Spurious emissions in the frequency range 5000 MHz–10000 MHz (GMSK modulation).

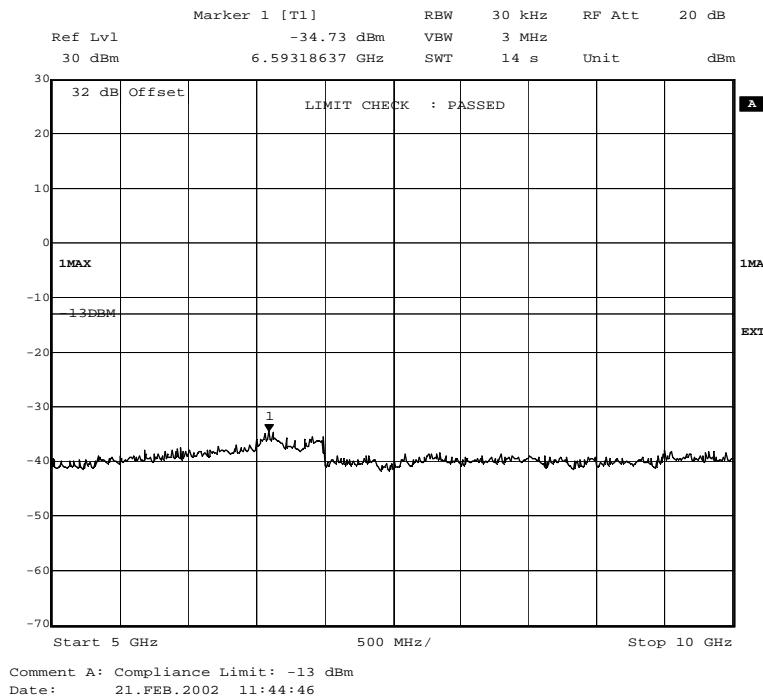

Fig. 27 – Spurious emissions in the frequency range 5000 MHz–10000 MHz (8PSK modulation).

Note: The external attenuation of 32 dB is included in the spectral plot. This accounts for the external attenuator and the cable loss during the testing.

**Test No. 4: Spurious Emissions at the Antenna Terminals
(Carrier Test Frequency = 893.6 MHz)**

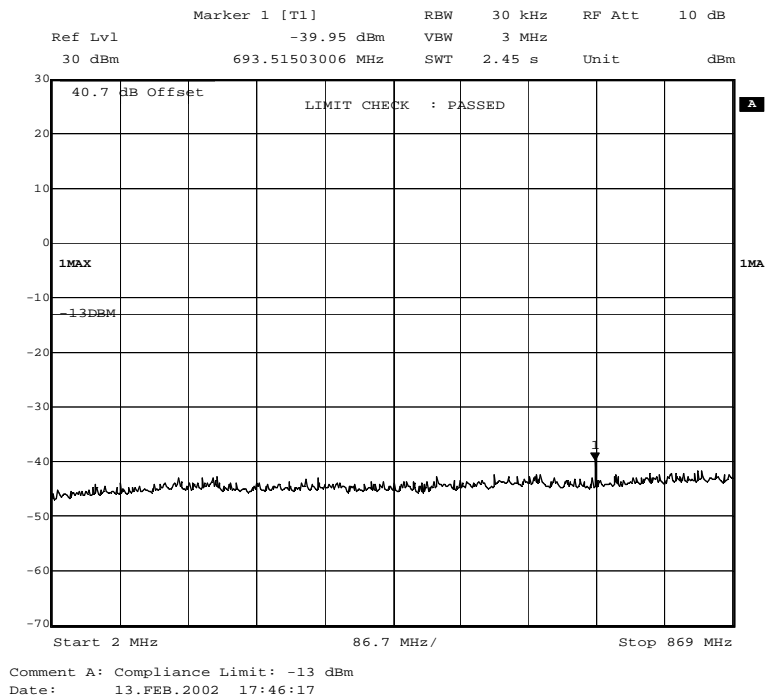

Fig. 28 – Spurious emissions in the frequency range 2 MHz – 869 MHz (GMSK modulation).

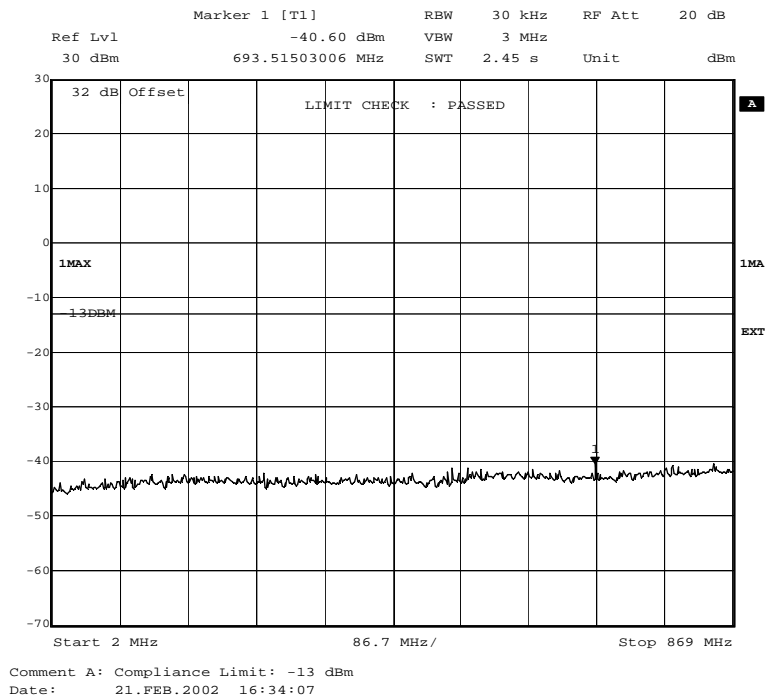

Fig. 29 – Spurious emissions in the frequency range 2 MHz – 869 MHz (8PSK modulation).

Note: The external attenuation of 32 dB is included in the spectral plot. This accounts for the external attenuator and the cable loss during the testing.

**Test No. 4: Spurious Emissions at the Antenna Terminals
(Carrier Test Frequency = 893.6 MHz)**

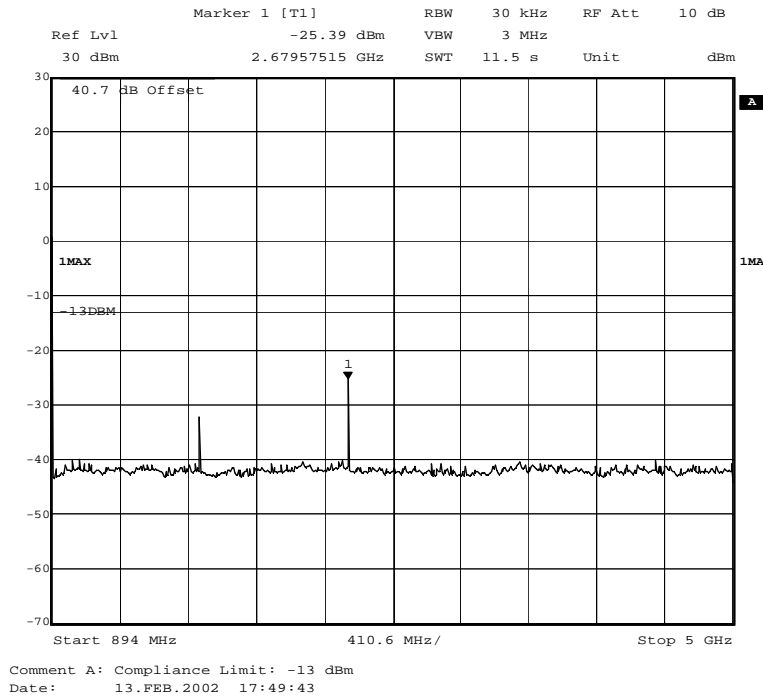

Fig. 30 – Spurious emissions in the frequency range 894 MHz – 5000 MHz (GMSK modulation).

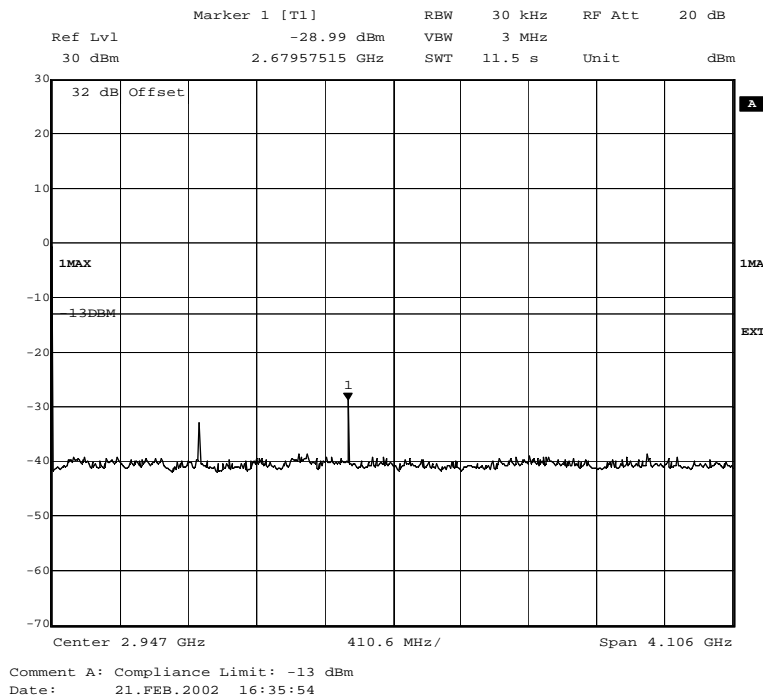

Fig. 31 – Spurious emissions in the frequency range 894 MHz – 5000 MHz (8PSK modulation).

Note: The external attenuation of 32 dB is included in the spectral plot. This accounts for the external attenuator and the cable loss during the testing.

**Test No. 4: Spurious Emissions at the Antenna Terminals
(Carrier Test Frequency = 893.6MHz)**

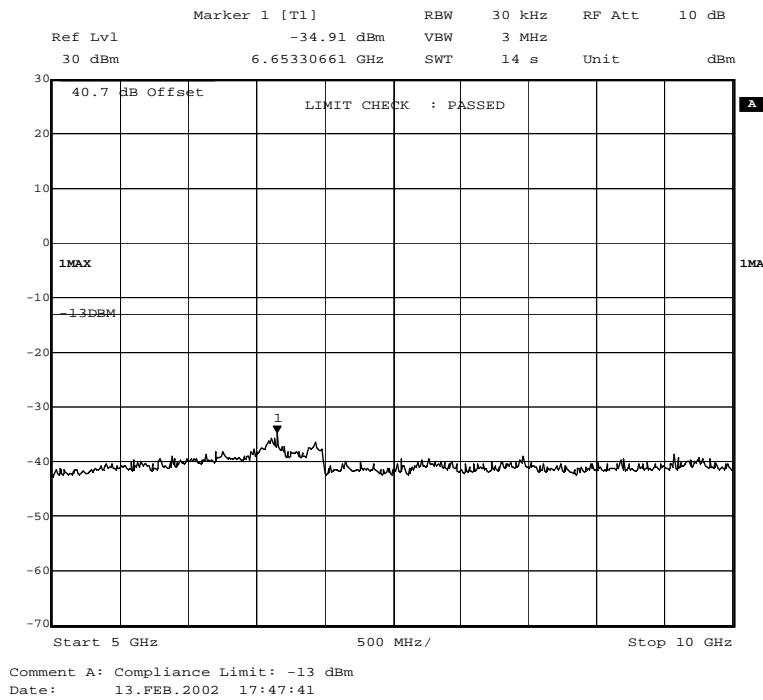

Fig. 32 – Spurious emissions in the frequency range 5000 MHz–10000 MHz (GMSK modulation).

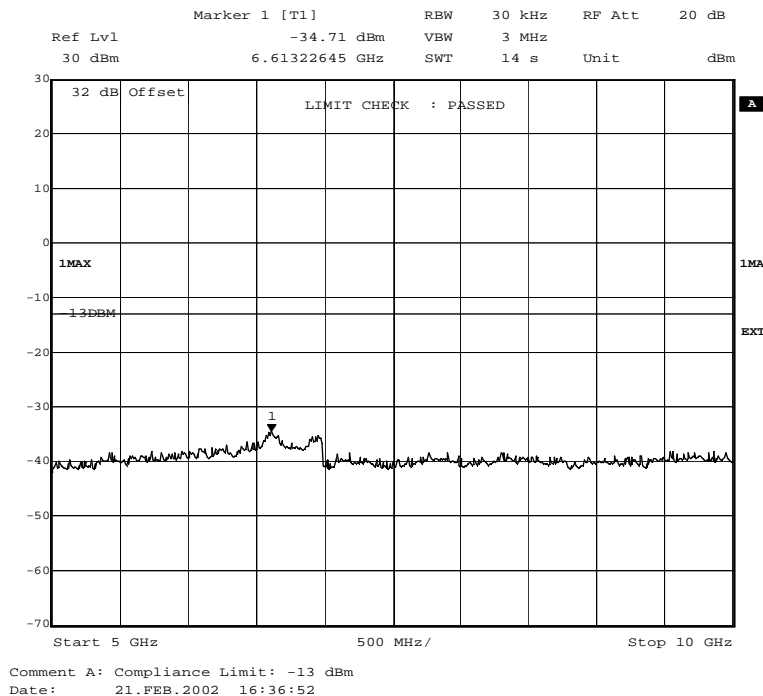

Fig. 33 – Spurious emissions in the frequency range 5000 MHz–10000 MHz (8PSK modulation).

Note: The external attenuation of 32 dB is included in the spectral plot. This accounts for the external attenuator and the cable loss during the testing.

Test No. 5: Field Strength of Spurious Radiation

Fig. 34 -- Photograph of the anechoic chamber with the EUT.



Fig. 35 -- Photograph of the anechoic chamber with the test configuration for substitution method.

Test No. 5: Field strength of spurious radiation

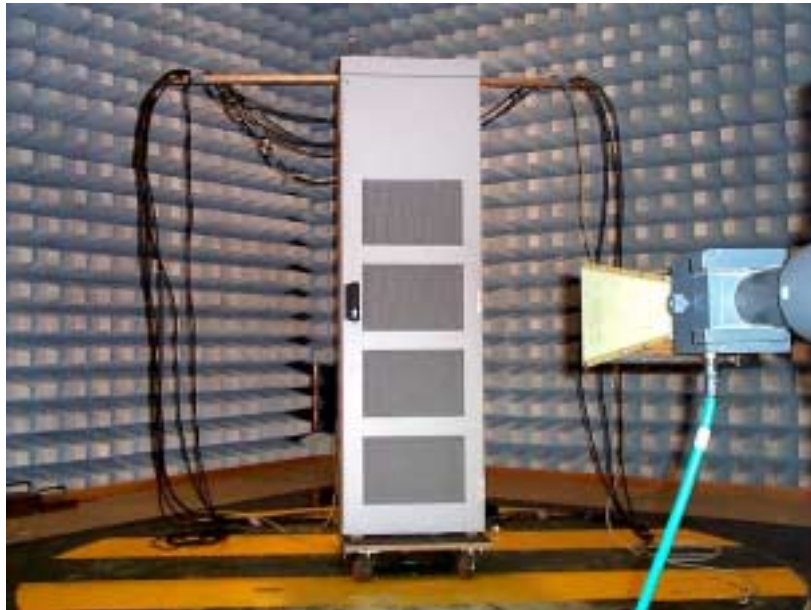
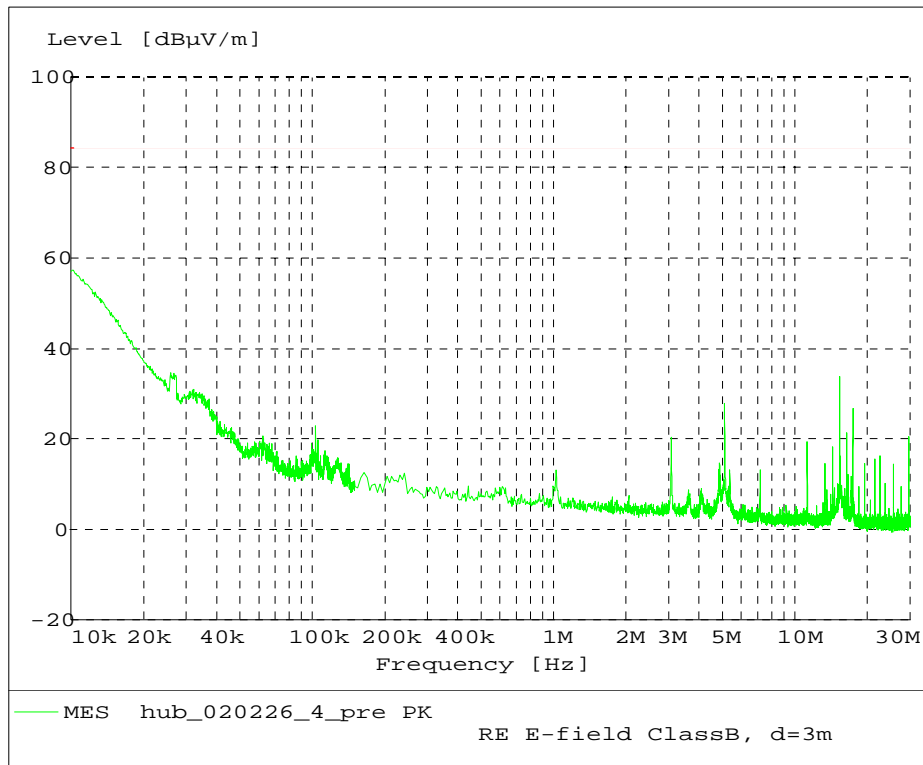

Fig. 36 – Radiated Emission 10 kHz – 30 MHz, GMSK modulation.

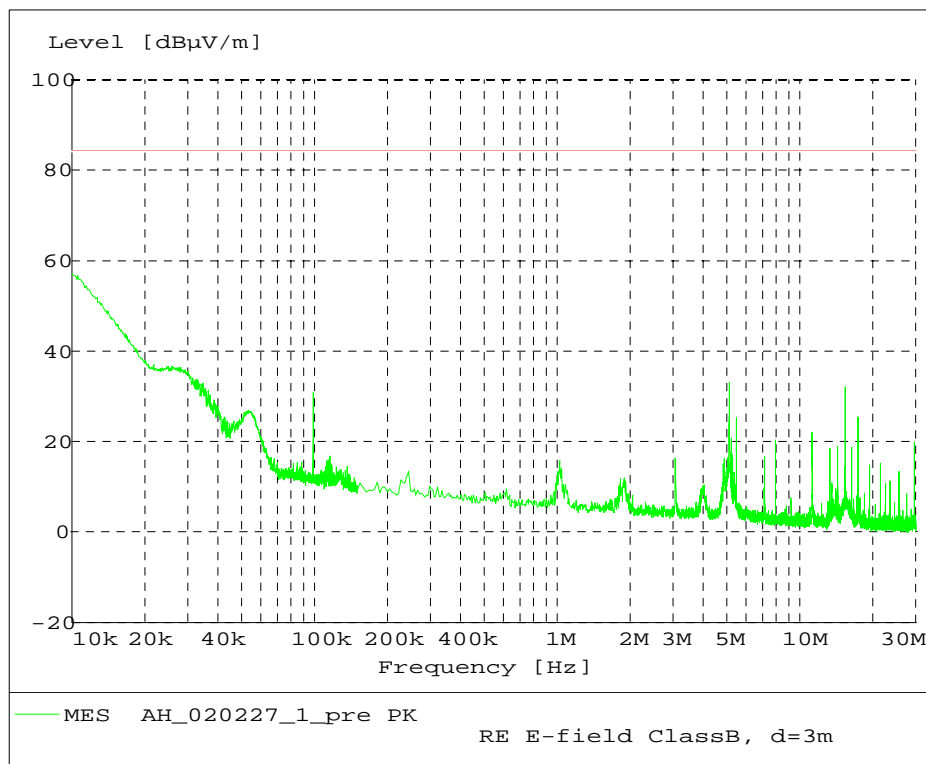

Fig. 37 – Radiated Emission 10 kHz – 30 MHz, 8PSK modulation.

Test No. 5: Field strength of spurious radiation

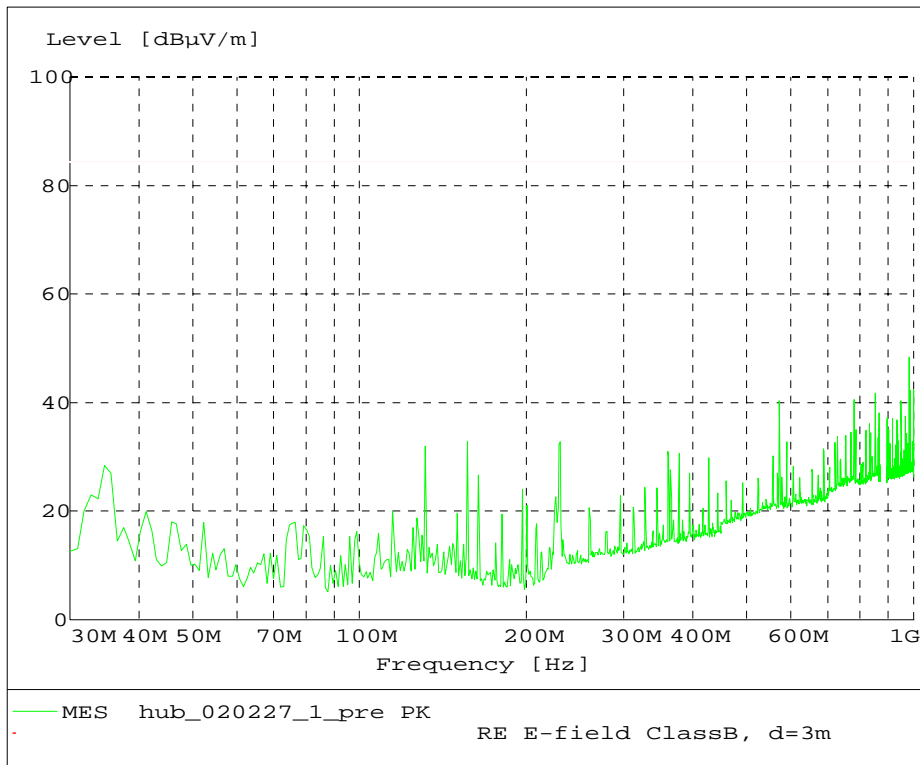

Fig. 38 – Radiated Emission 30 MHz – 1 GHz, GMSK modulation.

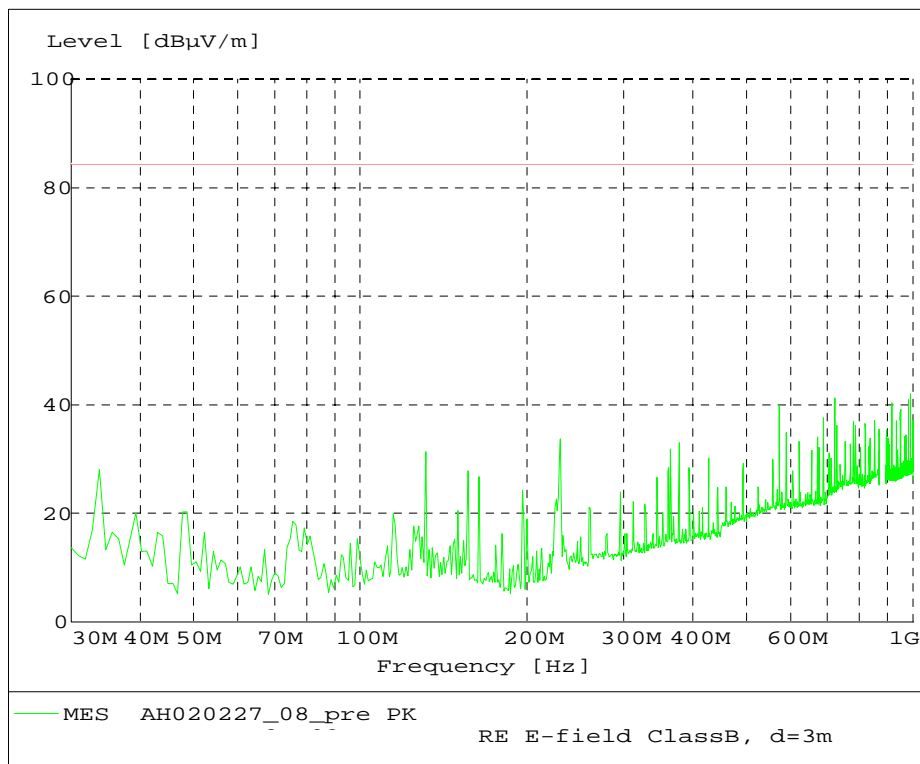

Fig. 39 – Radiated Emission 30 MHz – 1 GHz, 8PSK modulation.

Test No. 5: Field strength of spurious radiation

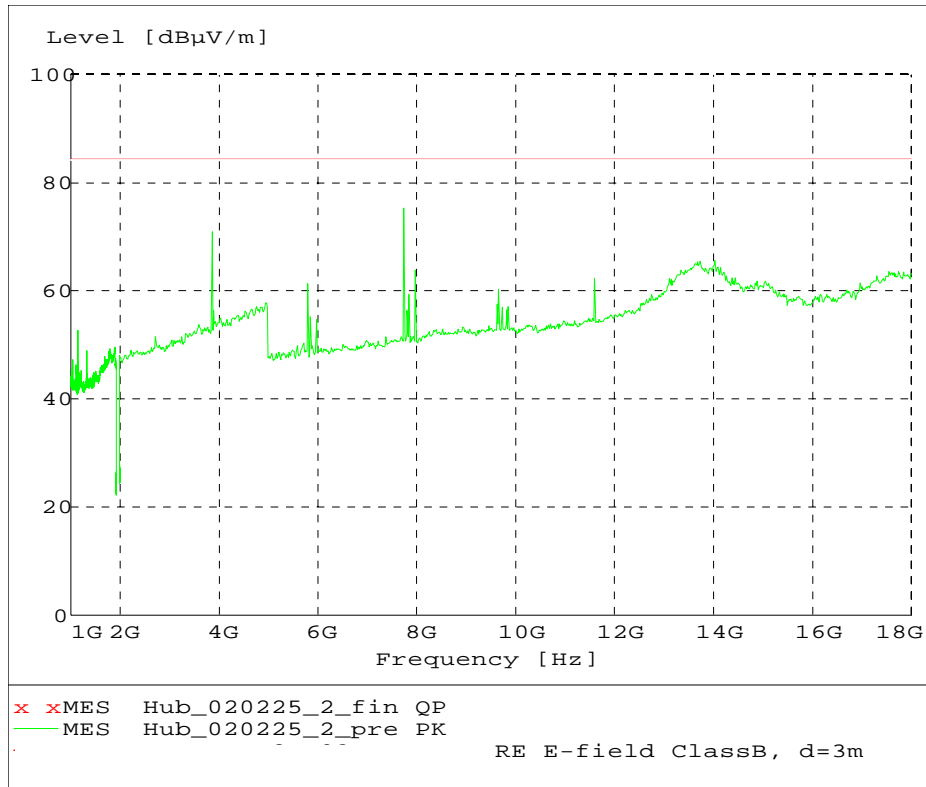

Fig. 40 – Radiated Emission 1 GHz – 18 GHz, GMSK modulation.

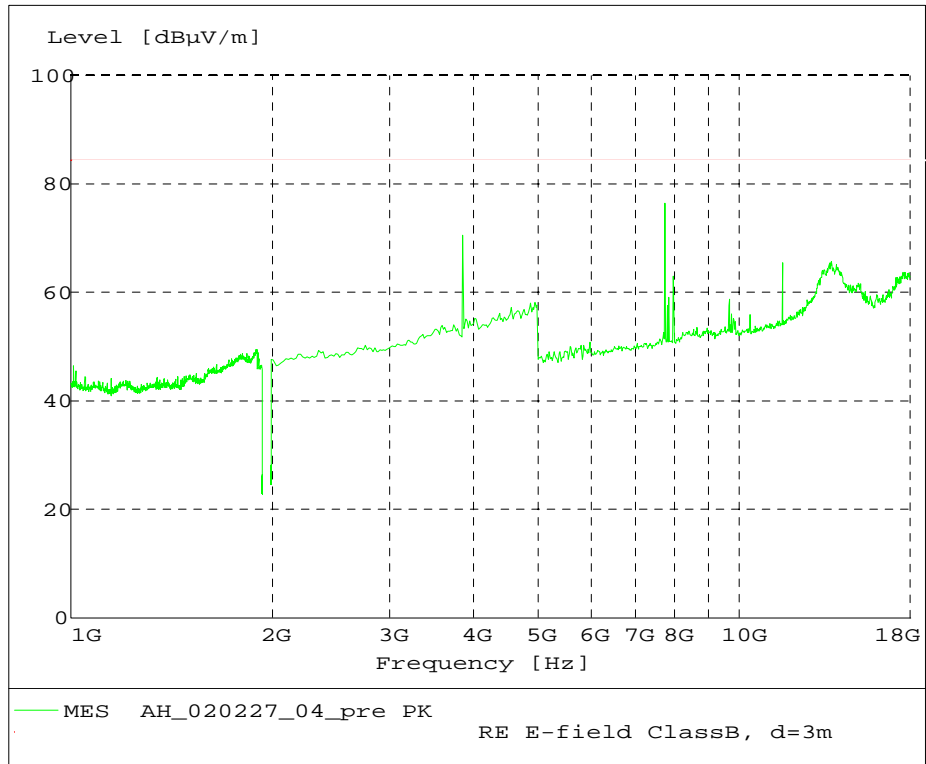

Fig. 41 – Radiated Emission 1 GHz – 18 GHz, 8PSK modulation.

Test No. 5: Field strength of spurious radiation

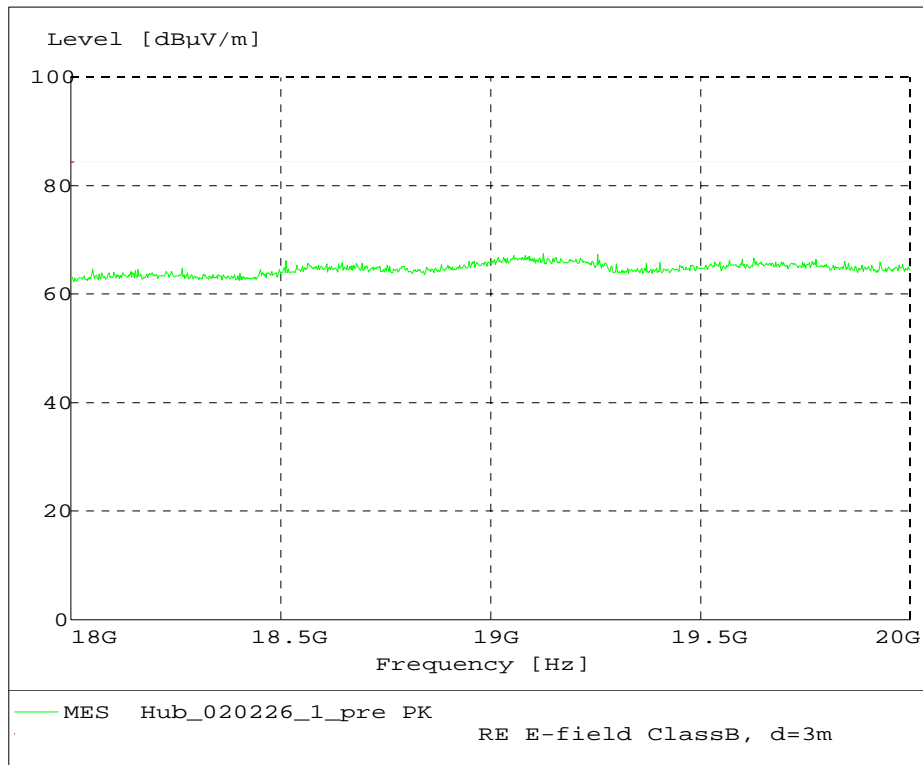

Fig. 42 – Radiated Emission 18 GHz – 20 GHz, GMSK modulation.

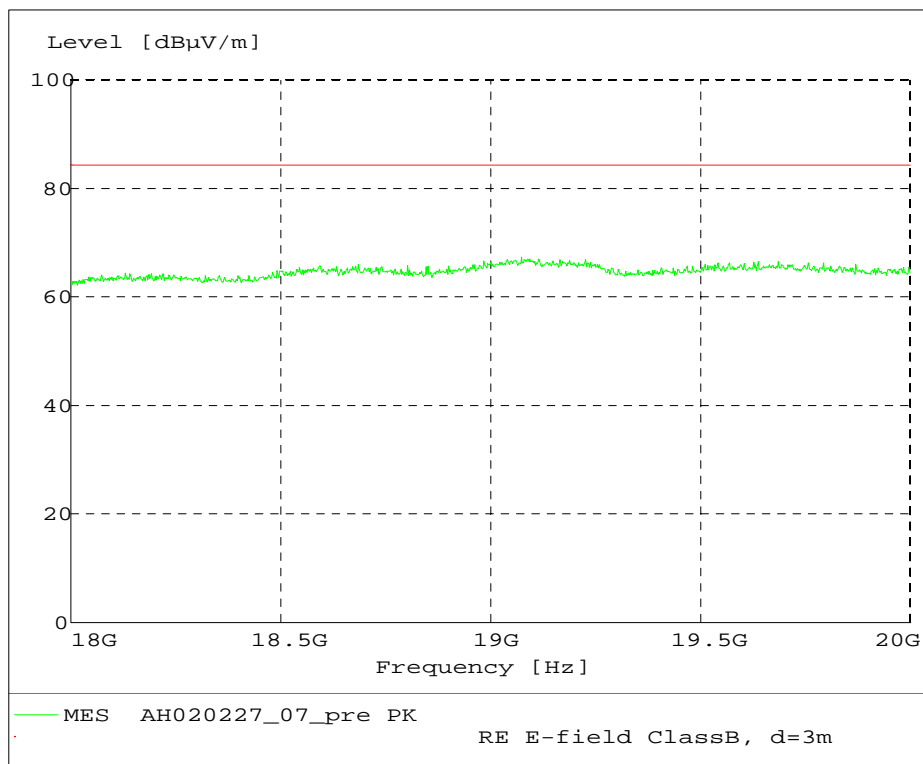

Fig. 43 – Radiated Emission 18 GHz – 20 GHz, 8PSK modulation.

Note: The frequencies shown on the plots were used for the spurious emission measurements using the "dipole substitution method".

Test No. 6: Frequency Stability

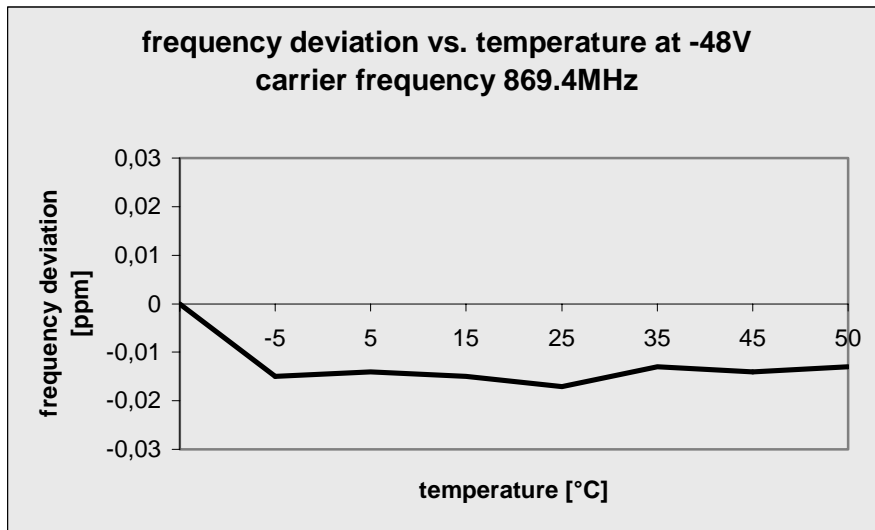

Fig. 44 – Frequency deviation vs. temperature (-48V, 869.4 MHz, GMSK modulation)

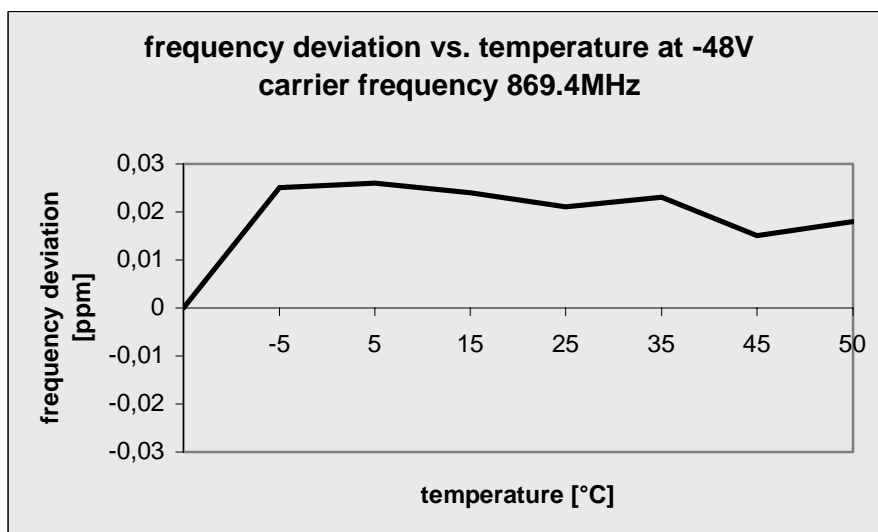

Fig. 45 – Frequency deviation vs. temperature (-48V, 869.4 MHz, 8PSK modulation)

Test No. 6: Frequency Stability

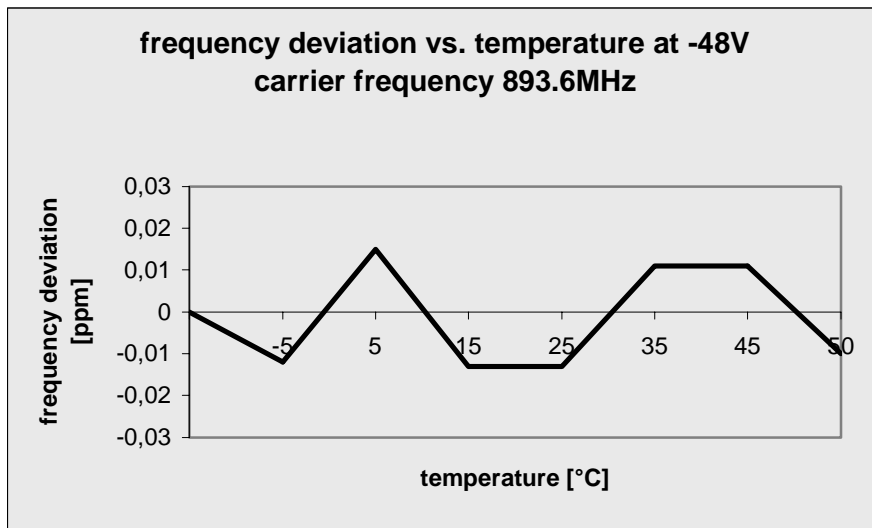

Fig. 46 – Frequency deviation vs. temperature (-48V, 893.6 MHz, GMSK modulation)

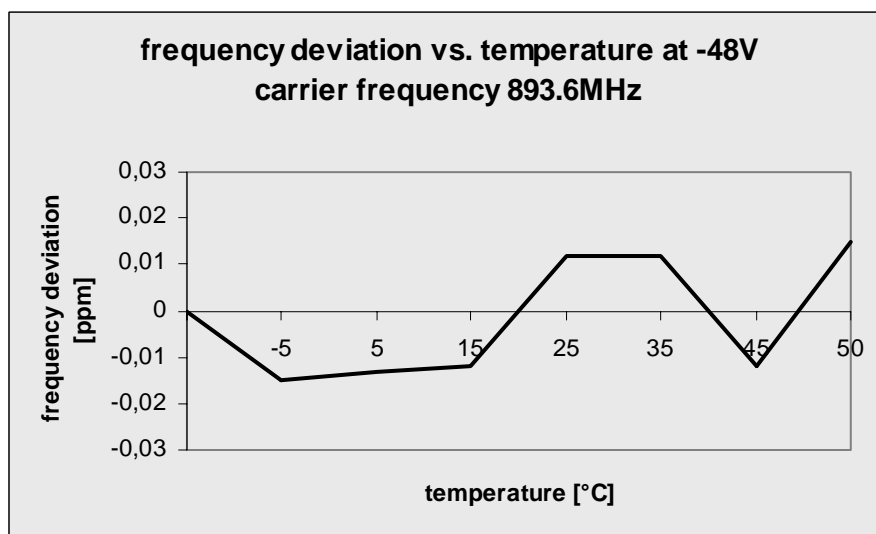

Fig. 47 – Frequency deviation vs. temperature (-48V, 893.6 MHz, 8PSK modulation)

Test No. 7: Slow Frequency Hopping

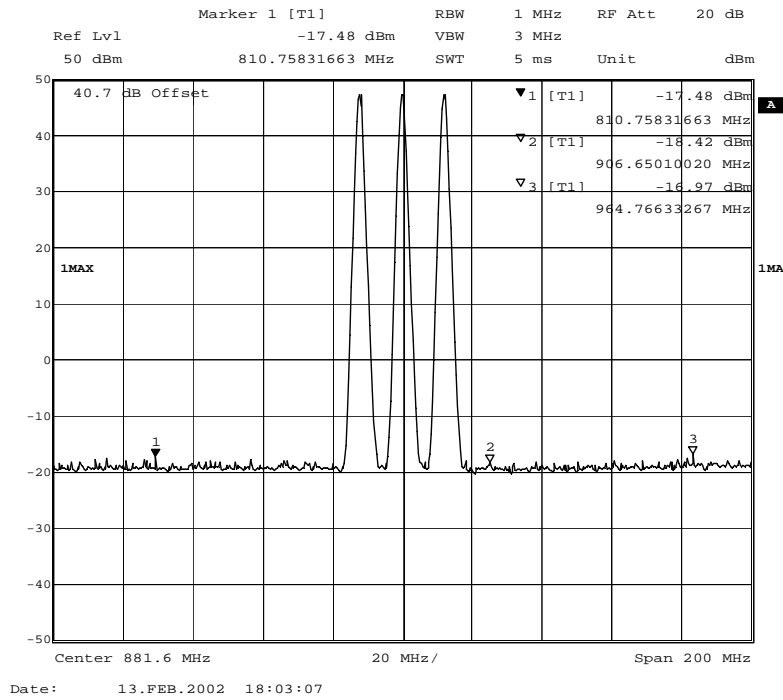

Fig. 48 – Slow frequency hopping – RBW = 1 MHz (GMSK modulation)

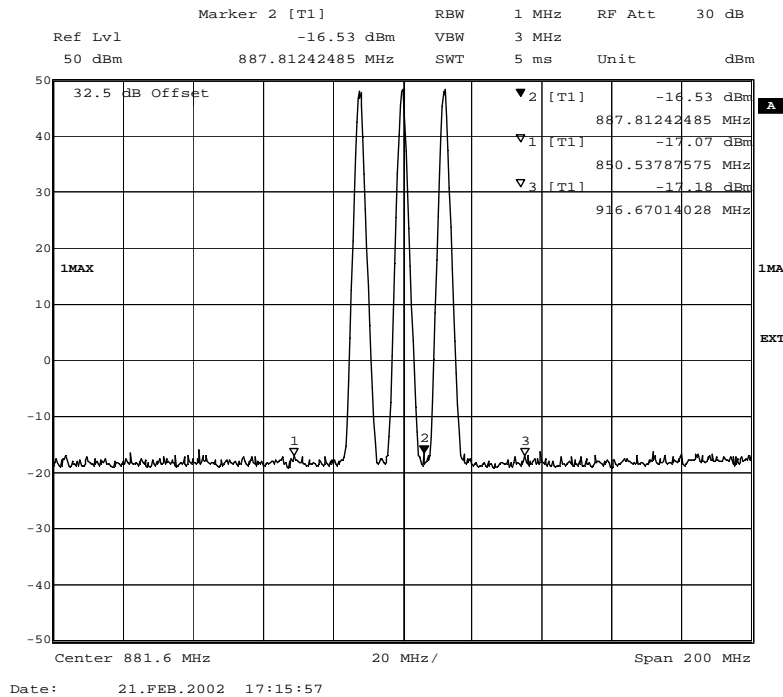

Fig. 49 – Slow frequency hopping – RBW = 1 MHz (8PSK modulation)

Note: The external attenuation of 32 dB is included in the spectral plot. This accounts for the external attenuator and the cable loss during the testing.

Test No. 7: Slow Frequency Hopping

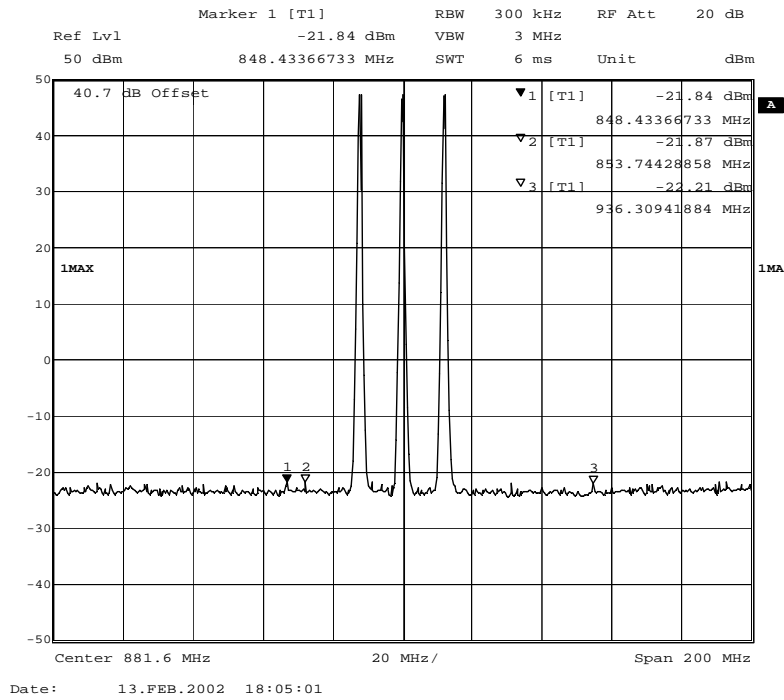

Fig. 50 – Slow frequency hopping – RBW = 300 kHz (GMSK modulation)

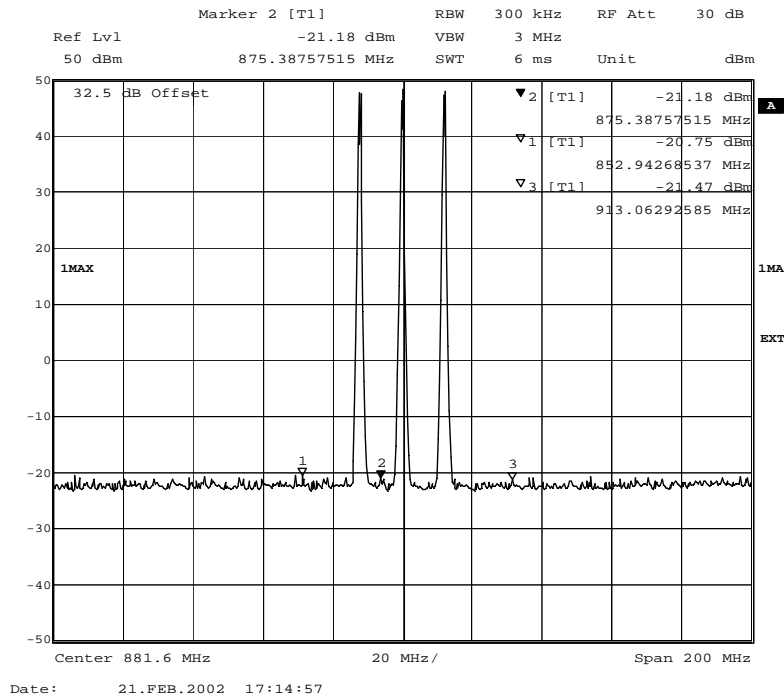

Fig. 51 – Slow frequency hopping – RBW = 300 kHz (8PSK modulation)

Note: The external attenuation of 32 dB is included in the spectral plot. This accounts for the external attenuator and the cable loss during the testing.

Test No. 7: Slow Frequency Hopping

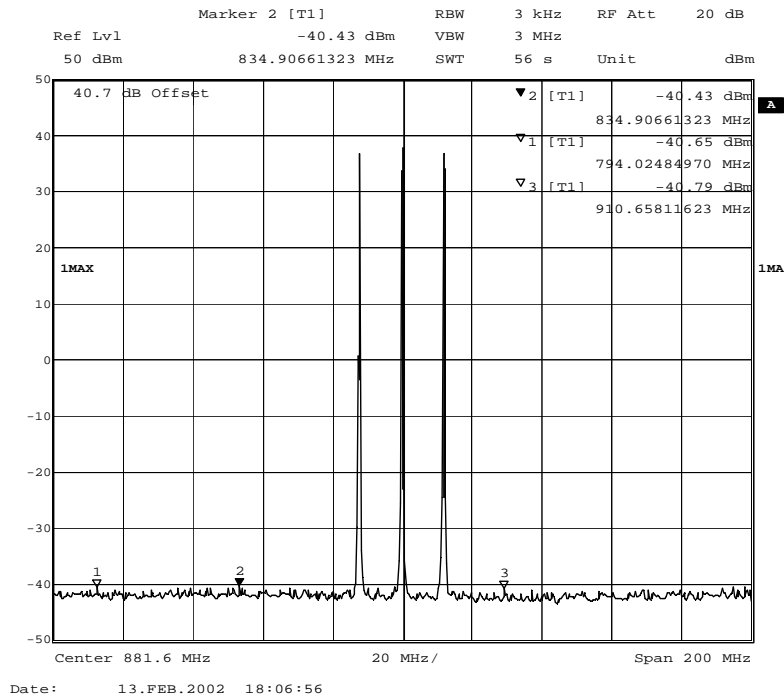

Fig. 52 – Slow frequency hopping – RBW = 3 kHz (GMSK modulation)

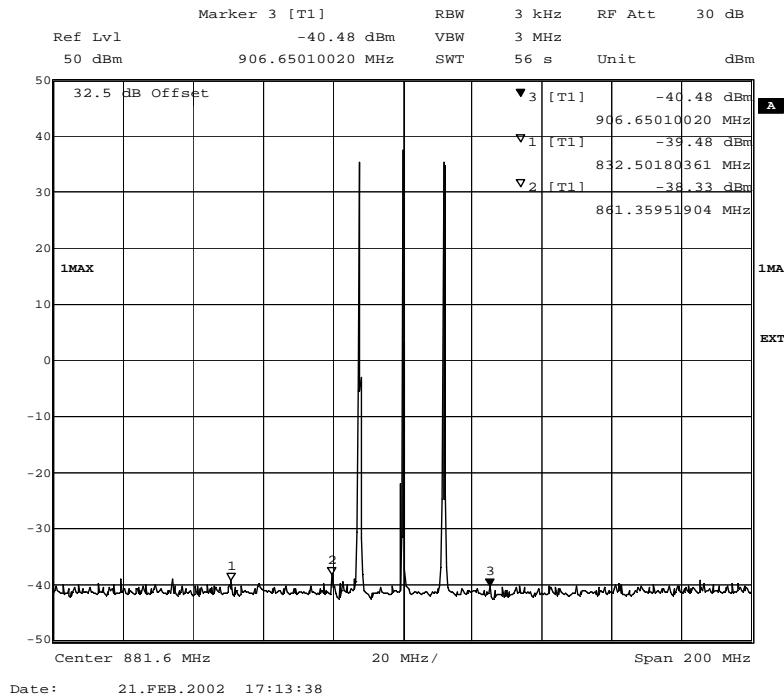

Fig. 53 – Slow frequency hopping – RBW = 3 kHz (8PSK modulation)

Note: The external attenuation of 32 dB is included in the spectral plot. This accounts for the external attenuator and the cable loss during the testing.

Test No. 7: Slow Frequency Hopping

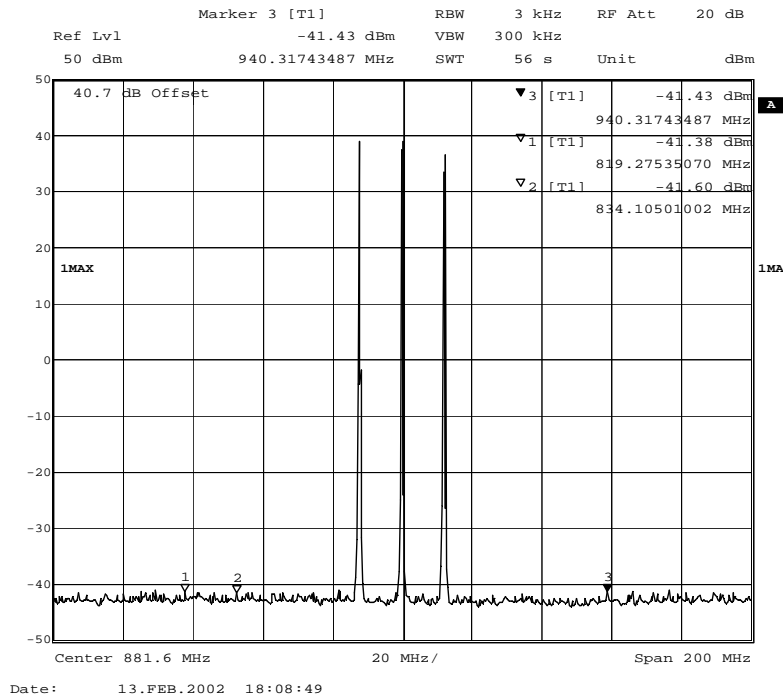

Fig. 54 – Slow frequency hopping – RBW = 3 kHz, reduced video bandwidth VBW = 300kHz (GMSK modulation)

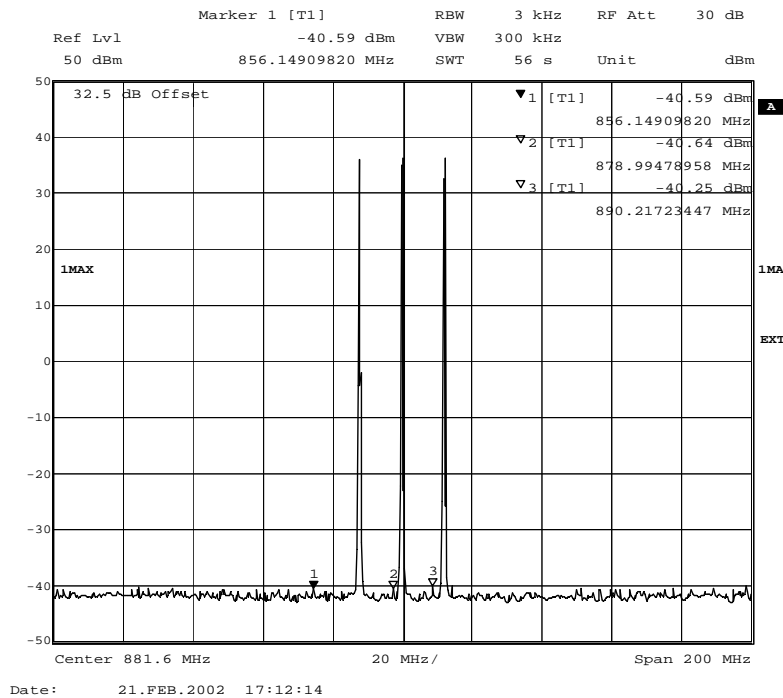

Fig. 55 – Slow frequency hopping – RBW = 3 kHz, reduced video bandwidth VBW = 300kHz (8PSK modulation)

Note: The external attenuation of 32 dB is included in the spectral plot. This accounts for the external attenuator and the cable loss during the testing.