

FCC 47 CFR PART 15 SUBPART C

Product Type : Handheld Terminal
Applicant : Partner Tech Corp.
Address : 10F, NO.233-2. PAO CHIAO ROAD, HSIN TIEN, TAIPEI,
TAIWAN, R. O. C.
Trade Name : PARTNER
Model Number : OT-200
Test Specification : FCC 47 CFR PART 15 SUBPART C: Oct., 2009
Canada RSS-210 ISSUE 7: Jun., 2007
Canada RSS-Gen ISSUE 2: Jun., 2007
ANSI C63.4-2003
Issue Date : Nov. 18, 2010

Issue by

A Test Lab Techno Corp.
No. 140-1, Changan Street, Bade City,
Taoyuan County 334, Taiwan R.O.C.
Tel : +886-3-2710188 / Fax : +886-3-2710190



Taiwan Accreditation Foundation accreditation number: 1330

Note: This report shall not be reproduced except in full, without the written approval of A Test Lab Techno Corp. This document may be altered or revised by A Test Lab Techno Corp. personnel only, and shall be noted in the revision section of the document. The client should not use it to claim product endorsement by TAF, or any government agencies. The test results in the report only apply to the tested sample.

Revision History

Rev.	Issue Date	Revisions	Revised By
00	Nov. 18, 2010	Initial Issue	

Verification

Issued Date: 2010/11/18

Product Type : Handheld Terminal
Applicant : Partner Tech Corp.
Address : 10F, NO.233-2. PAO CHIAO ROAD, HSIN TIEN, TAIPEI,
TAIWAN, R. O. C.
Trade Name : PARTNER
Model Number : OT-200
FCC ID : NDPOT-200
EUT Rated Voltage : DC 5.0V, 2.0A
Test Voltage : 120 Vac / 60 Hz
Applicable Standard : FCC 47 CFR PART 15 SUBPART C: Oct., 2009
Canada RSS-210 ISSUE 7: Jun., 2007
Canada RSS-Gen ISSUE 2: Jun., 2007
ANSI C63.4-2003

Test Result : Complied

Performing Lab. : A Test Lab Techno Corp.

No. 140-1, Changan Street, Bade City,
Taoyuan County 334, Taiwan R.O.C.

Tel : +886-3-2710188 / Fax : +886-3-2710190

Taiwan Accreditation Foundation accreditation number:
1330



<http://www.atl-lab.com.tw/e-index.htm>

The above equipment has been tested by A Test Lab Techno Corp., and found compliance with the requirements set forth in the Electromagnetic Compatibility Directive 2004/108/EC and technical standards mentioned above. The results of testing in this report apply only to the product/system, which was tested. Other similar equipment will not necessarily produce the same results due to production tolerance and measurement uncertainties.

Approved By : 
(Manager) (Miller Lee)

Reviewed By : 
(Testing Engineer) (Gary Wu)

TABLE OF CONTENTS

1	General Information	6
2	EUT Description	7
3	Test Methodology.....	8
	3.1. Mode of Operation.....	8
	3.2. EUT Exercise Software.....	9
	3.3. Configuration of Test System Details.....	9
	3.4. Test Site Environment.....	9
4	Conducted Emission Measurement	10
	4.1. Limit	10
	4.2. Test Instruments	10
	4.3. Test Setup.....	10
	4.4. Test Procedure.....	11
	4.5. Test Result.....	12
5	Radiated Interference Measurement	16
	5.1. Limit	16
	5.2. Test Instruments	16
	5.3. Setup	17
	5.4. Test Procedure.....	17
	5.5. Test Result.....	19
6	Maximum Conducted Output Power Measurement.....	25
	6.1. Limit	25
	6.2. Test Setup.....	25
	6.3. Test Instruments	25
	6.4. Test Procedure.....	25
	6.5. Test Result.....	26
7	Minimum 20dB RF Bandwidth Measurement	28
	7.1. Limit	28
	7.2. Test Setup.....	28
	7.3. Test Instruments	28
	7.4. Test Procedure.....	28
	7.5. Test Result.....	29
	7.6. Test Graphs	30
8	Carrier Frequency Separation Measurement	32
	8.1. Limit	32
	8.2. Test Setup.....	32
	8.3. Test Instruments	32
	8.4. Test Procedure.....	33
	8.5. Test Result.....	33
	8.6. Test Graphs	34

9	Number of Hopping Measurement	35
9.1.	Limit	35
9.2.	Test Setup.....	35
9.3.	Test Instruments	35
9.4.	Test Procedure.....	35
9.5.	Test Result.....	36
9.6.	Test Graphs	37
10	Time of Occupancy (Dwell Time) Measurement.....	39
10.1.	Limit	39
10.2.	Test Setup.....	39
10.3.	Test Instruments	39
10.4.	Test Procedure.....	39
10.5.	Test Result.....	40
10.6.	Test Graphs	42
11	Out of Band Conducted Emissions Measurement	44
11.1.	Limit	44
11.2.	Test Setup.....	44
11.3.	Test Instruments	44
11.4.	Test Procedure.....	44
11.5.	Test Graphs	45
12	Band Edges Measurement	47
12.1.	Limit	47
12.2.	Test Setup.....	47
12.3.	Test Instruments	47
12.4.	Test Procedure.....	48
12.5.	Test Result.....	49
13	99 % Occupied Bandwidth Measurement	57
13.1.	Limit	57
13.2.	Test Setup.....	57
13.3.	Test Instruments	57
13.4.	Test Procedure.....	57
13.5.	Test Result.....	58
13.6.	Test Graphs	59
14	Antenna Measurement.....	61
14.1.	Limit	61
14.2.	Antenna Connector Construction	61

1 General Information

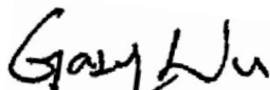
1.1 Summary of Test Result

Standard		Item	Result	Remark
15.247	RSS-GEN			
15.207	7.2.2	AC Power Conducted Emission	PASS	-----
-----	6	Receiver Radiated Emissions	PASS	-----
Standard		Item	Result	Remark
15.247	RSS-210			
15.247(c)	A8.5	Transmitter Radiated Emissions	PASS	-----
15.247(b)(1)	A8.4 (2)	Max. Output Power	PASS	-----
15.247(a)(1)	A8.1 (1)	20dB RF Bandwidth	PASS	-----
15.247(a)(1)(iii)	A8.1 (2)	Carrier Frequency Separation	PASS	-----
15.247(a)(1)(iii)	A8.1 (4)	Number of Hopping	PASS	-----
15.247(a)(1)(iii)	A8.1 (4)	Time of Occupancy (Dwell Time)	PASS	-----
15.247(c)	A8.5	Out of Band Conducted Spurious Emission	PASS	-----
15.247(c)	A8.5	Band Edge Measurement	PASS	-----
15.203	-	Antenna Requirement	PASS	-----

The test results of this report relate only to the tested sample(s) identified in this report. Manufacturer or whom it may concern should recognize the pass or fail of the test result.

1.2 Measurement Uncertainty

Conducted Emission

The measurement uncertainty is evaluated as ± 2.24 dB.

Radiated Emission

The measurement uncertainty of 30 MHz - 1GHz is evaluated as ± 3.072 dB.

2 EUT Description

Product	:	Handheld Terminal		
Trade Name	:	PARTNER		
Model Number	:	OT-200		
Applicant	:	Partner Tech Corp. 10F, NO.233-2. PAO CHIAO ROAD, HSIN TIEN,TAIPEI, TAIWAN, R. O. C.		
Manufacturer	:	Partner Tech Corp. 10F, NO.233-2. PAO CHIAO ROAD, HSIN TIEN,TAIPEI, TAIWAN, R. O. C.		
FCC ID	:	NDPOT-200		
Serial No.	:	T90310700206		
Frequency Range	:	2402 ~ 2480 MHz		
Modulation Type	:	GFSK for 1Mbps		
		$\pi/4$ -DQPSK for 2Mbps		
		8DPSK for 3Mbps		
Antenna Type	:	Internal Type		
Antenna Gain	:	2.94 dBi		
RF Output Power (Conducted)	:	GFSK for 1Mbps	3.44 dBm /	0.002208 W
		$\pi/4$ -DQPSK for 2Mbps	3.83 dBm /	0.002415 W
		8DPSK for 3Mbps	3.89 dBm /	0.002449 W
Component				
Battery	:	PARTNER, OT Series Battery DC 3.7V, 2300mAh		
Power Adapter (1)	:	Touch Electronic Co., Ltd., M8-10US05R Input:100-240Vac, 50-60Hz, 0.5A Output: 5.0 Vdc, 2.0A Cable out: Shielded, 1.8 m		
Power Adapter (2)	:	CWT, KPC-010B Input:100-240Vac, 50/60Hz, 0.8A Output: 5.0 Vdc, 2.0A Cable out: Shielded, 1.45 m		
Handheld Terminal Cradle	:	PARTNER, OT-100 Cradle Rating: 5.0 Vdc, 2.0A		

3 Test Methodology

3.1. Mode of Operation

Decision of Test ATL has verified the construction and function in typical operation. All the test modes were carried out with the EUT in normal operation, which was shown in this test report and defined as:

Test Mode
Mode 1: IDLE Mode
Mode 2: Normal Operation Mode
Mode 3: GFSK Link Mode
Mode 4: $\pi/4$ -DQPSK Link Mode
Mode 5: 8DPSK Link Mode
Mode 6: Receiver Mode

Description of Test Modes

Preliminary tests were performed in different modulation to find the worst case. The modulation shown in the table below is the worst-case. Investigation has been done on all the possible configurations for searching the worst cases. The following table is a list of the test modes shown in this test report.

Modulation Type	Channel	Frequency (MHz)	Packet Type	Peak Conducted Power		Worst Case
				(dBm)	(W)	
GFSK	Low	2402	DH1	3.44	0.00221	<input type="checkbox"/>
	Low	2402	DH3	3.42	0.00220	<input type="checkbox"/>
	Low	2402	DH5	3.35	0.00216	<input type="checkbox"/>
	Middle	2441	DH1	3.03	0.00201	<input type="checkbox"/>
	Middle	2441	DH3	3.08	0.00203	<input type="checkbox"/>
	Middle	2441	DH5	3.09	0.00204	<input type="checkbox"/>
	High	2480	DH1	1.74	0.00149	<input type="checkbox"/>
	High	2480	DH3	1.73	0.00149	<input type="checkbox"/>
	High	2480	DH5	1.73	0.00149	<input type="checkbox"/>
$\pi/4$ -DQPSK	Low	2402	2DH1	3.76	0.00238	<input type="checkbox"/>
	Low	2402	2DH3	3.83	0.00242	<input type="checkbox"/>
	Low	2402	2DH5	3.81	0.00240	<input type="checkbox"/>
	Middle	2441	2DH1	3.39	0.00218	<input type="checkbox"/>
	Middle	2441	2DH3	3.40	0.00219	<input type="checkbox"/>
	Middle	2441	2DH5	3.33	0.00215	<input type="checkbox"/>
	High	2480	2DH1	1.98	0.00158	<input type="checkbox"/>
	High	2480	2DH3	2.00	0.00158	<input type="checkbox"/>
	High	2480	2DH5	2.01	0.00159	<input type="checkbox"/>
8DPSK	Low	2402	3DH1	3.89	0.00245	<input checked="" type="checkbox"/>
	Low	2402	3DH3	3.82	0.00241	<input type="checkbox"/>
	Low	2402	3DH5	3.82	0.00241	<input type="checkbox"/>
	Middle	2441	3DH1	3.42	0.00220	<input type="checkbox"/>
	Middle	2441	3DH3	3.40	0.00219	<input type="checkbox"/>
	Middle	2441	3DH5	3.44	0.00221	<input type="checkbox"/>
	High	2480	3DH1	2.11	0.00163	<input type="checkbox"/>
	High	2480	3DH3	1.99	0.00158	<input type="checkbox"/>
	High	2480	3DH5	2.04	0.00160	<input type="checkbox"/>

Tested System Details

The types for all equipments, plus descriptions of all cables used in the tested system (including inserted cards) are:

	Product	Manufacturer	Model Number	Serial Number	Power Cord
1.	Bluetooth Tester	R & S	CBT	100350	NA

3.2. EUT Exercise Software

1.	Setup the EUT and Bluetooth Tester (CBT) as shown on 3.3.
2.	Turn on the power of all equipment.
3.	EUT run test program.
4.	Open Bluetooth function link to CBT.

3.3. Configuration of Test System Details

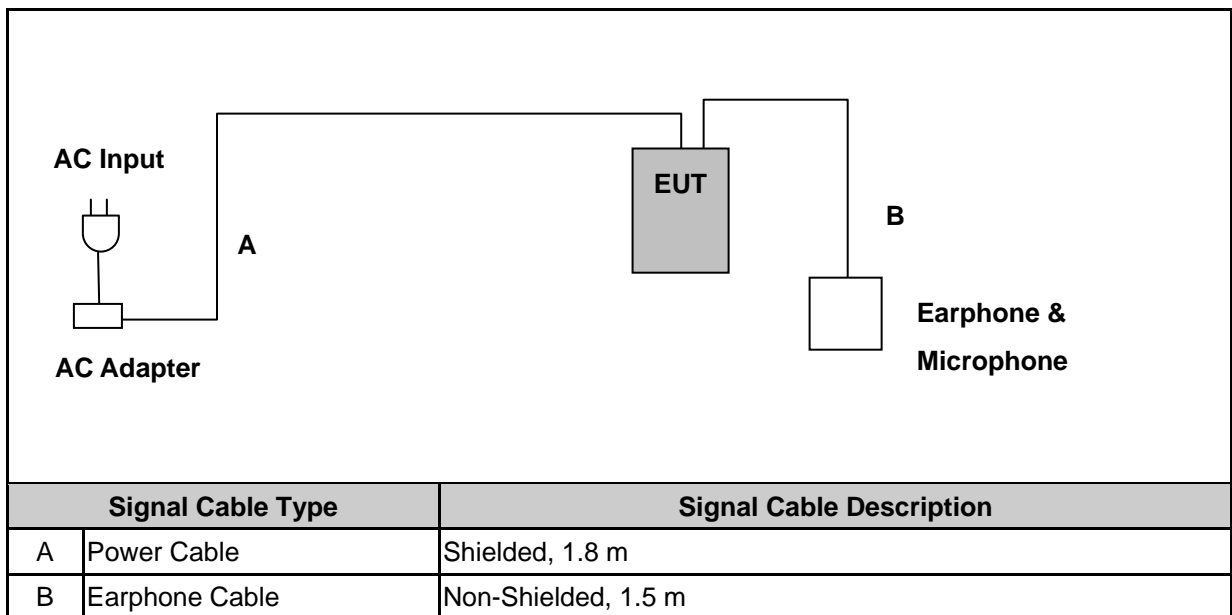

3.4. Test Site Environment

Items	Required (IEC 68-1)	Actual
Temperature (°C)	15-35	25
Humidity (%RH)	25-75	50
Barometric pressure (mbar)	860-1060	950

4 Conducted Emission Measurement

4.1. Limit

Frequency (MHz)	Quasi-peak	Average
0.15 - 0.5	66 to 56	56 to 46
0.50 - 5.0	56	46
5.0 - 30.0	60	50

4.2. Test Instruments

Describe	Manufacturer	Model Number	Serial Number	Cal. Date	Remark
Test Receiver	R&S	ESCI	100367	07/01/2009	(1)
LISN	R&S	ENV216	101040	03/02/2010	(1)
LISN	R&S	ENV216	101041	03/02/2010	(1)
Test Site	ATL	TE02	TE02	N.C.R.	-----

Remark: ⁽¹⁾ Calibration period 1 year. ⁽²⁾ Calibration period 2 years.

NOTE: N.C.R. = No Calibration Request.

4.3. Test Setup

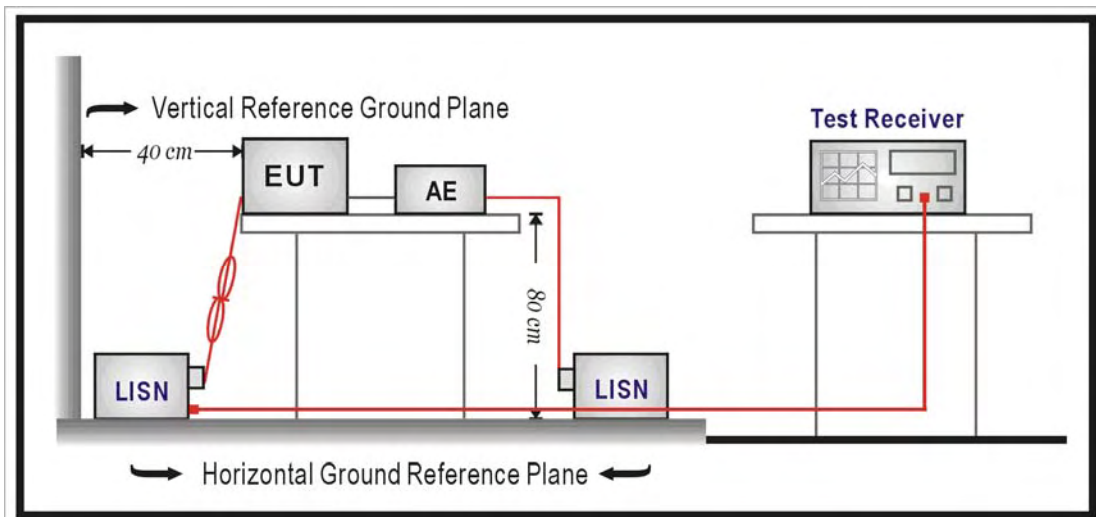

4.4. Test Procedure

The power line conducted emission measurements were performed in a shielded enclosure. The EUT was assembled on a wooden table which is 80 centimeters high, was placed 40 centimeters from the back wall and at least 1 meter from the sidewall.

Power was fed to the EUT from the public utility power grid through a line filter and EMCO Model 3162/2 SH Line Impedance Stabilization Networks (LISN). The LISN housing, measuring instrumentation case, ground plane, etc., were electrically bonded together at the same RF potential. The Spectrum analyzer was connected to the AC line through an isolation transformer. The 50-ohm output of the LISN was connected to the spectrum analyzer directly. Conducted emission levels were in the CISPR quasi-peak detection mode. The analyzer's 6 dB bandwidth was set to 9 KHz. No post-detector video filter was used.

The spectrum was scanned from 150 KHz to 30 MHz. The physical arrangement of the test system and associated cabling was varied (within the scope of arrangements likely to be encountered in actual use) to determine the effect on the unit's emanations in amplitude and frequency. All spurious emission frequencies were observed. The highest emission amplitudes relative to the appropriate limit were measured and have been recorded in paragraph 4.1.

4.5. Test Result

Standard:	FCC Part 15C	Line:	L1
Test item:	Conducted Emission	Power:	AC 120V/60Hz
Model:	OT-200	Temp.(°C)/Hum.(%RH):	26(°C)/60%RH
Mode:	Mode 1	Date:	2010/06/17
		Test By:	Gary Wu
Description:			

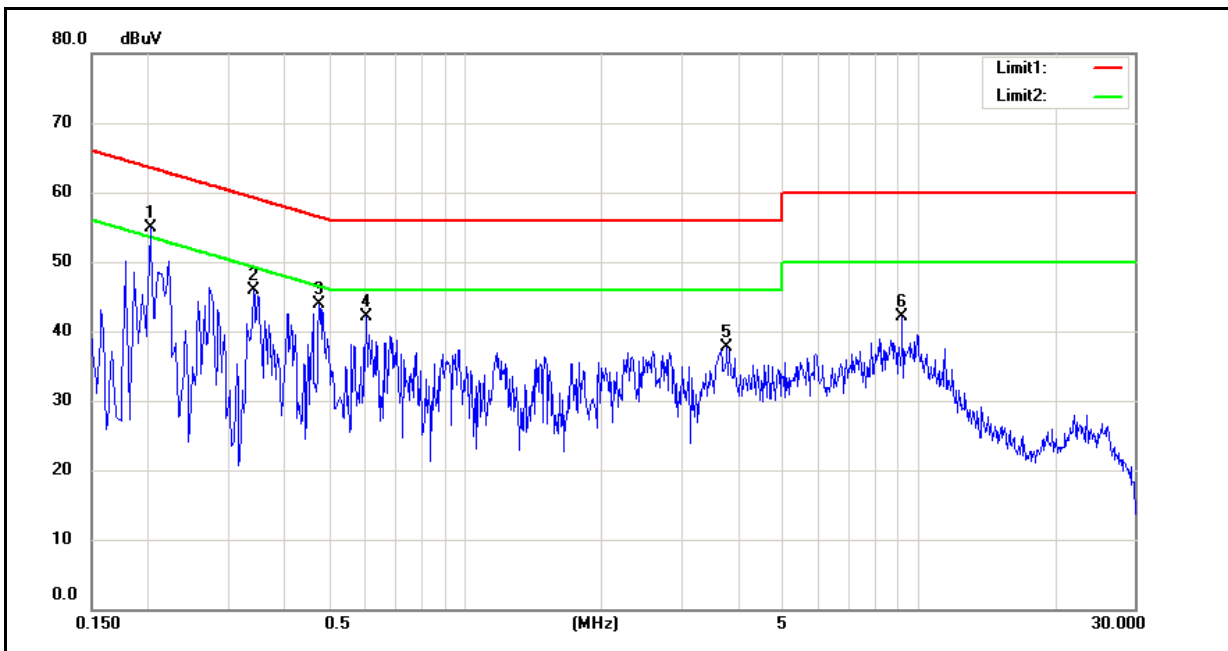

No.	Frequency (MHz)	QP reading (dBuV)	AVG reading (dBuV)	Correction factor (dB)	QP result (dBuV)	AVG result (dBuV)	QP limit (dBuV)	AVG limit (dBuV)	QP margin (dB)	AVG margin (dB)	Remark
1	0.2020	42.59	29.15	10.08	52.67	39.23	63.53	53.53	-10.86	-14.30	Pass
2	0.3420	32.30	19.43	10.02	42.32	29.45	59.15	49.15	-16.83	-19.70	Pass
3	0.4780	30.22	19.48	9.97	40.19	29.45	56.37	46.37	-16.18	-16.92	Pass
4	0.6060	25.49	14.20	9.91	35.40	24.11	56.00	46.00	-20.60	-21.89	Pass
5	3.7860	21.04	11.42	9.84	30.88	21.26	56.00	46.00	-25.12	-24.74	Pass
6	9.2420	21.42	12.02	10.13	31.55	22.15	60.00	50.00	-28.45	-27.85	Pass

Standard:	FCC Part 15C	Line:	N
Test item:	Conducted Emission	Power:	AC 120V/60Hz
Model:	OT-200	Temp.(°C)/Hum.(%RH):	26(°C)/60%RH
Mode:	Mode 1	Date:	2010/06/17
		Test By:	Gary Wu
Description:			

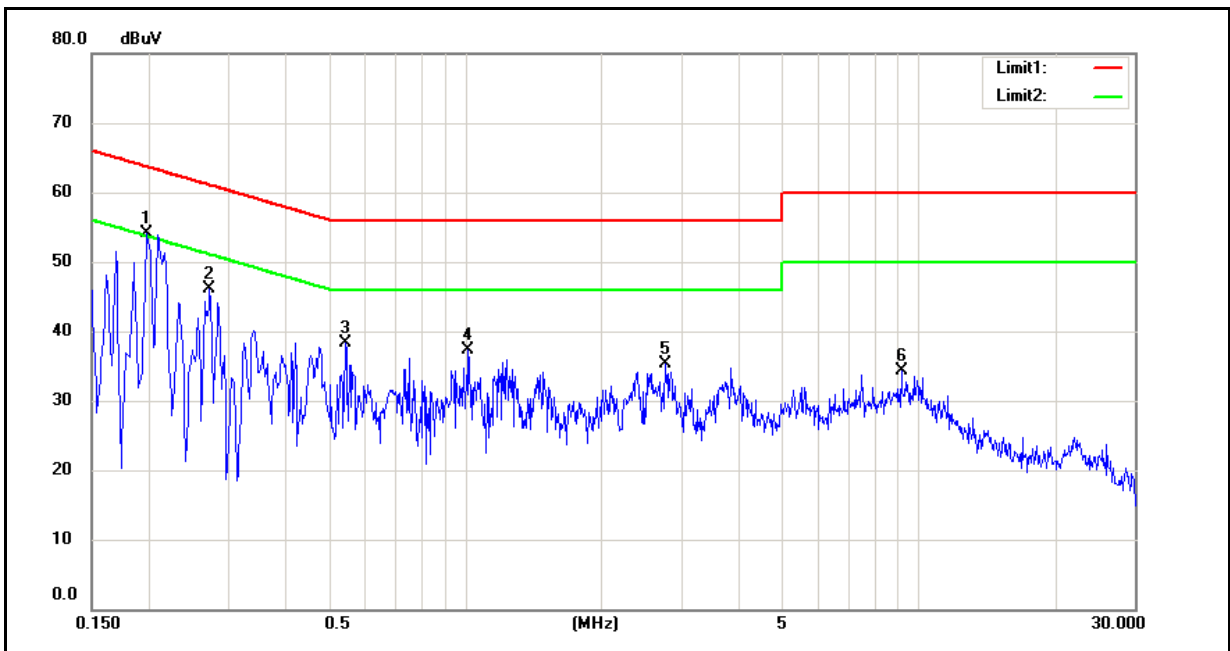

No.	Frequency (MHz)	QP reading (dBuV)	AVG reading (dBuV)	Correction factor (dB)	QP result (dBuV)	AVG result (dBuV)	QP limit (dBuV)	AVG limit (dBuV)	QP margin (dB)	AVG margin (dB)	Remark
1	0.1980	38.29	24.76	10.07	48.36	34.83	63.69	53.69	-15.33	-18.86	Pass
2	0.2740	32.59	18.62	10.04	42.63	28.66	61.00	51.00	-18.37	-22.34	Pass
3	0.5460	24.53	10.76	9.94	34.47	20.70	56.00	46.00	-21.53	-25.30	Pass
4	1.0180	22.74	10.62	9.74	32.48	20.36	56.00	46.00	-23.52	-25.64	Pass
5	2.7740	17.45	9.42	9.80	27.25	19.22	56.00	46.00	-28.75	-26.78	Pass
6	9.1700	16.33	9.72	10.12	26.45	19.84	60.00	50.00	-33.55	-30.16	Pass

Standard:	FCC Part 15C	Line:	L1
Test item:	Conducted Emission	Power:	AC 120V/60Hz
Model:	OT-200	Temp.(°C)/Hum.(%RH):	26(°C)/60%RH
Mode:	Mode 2	Date:	2010/06/17
		Test By:	Gary Wu
Description:			

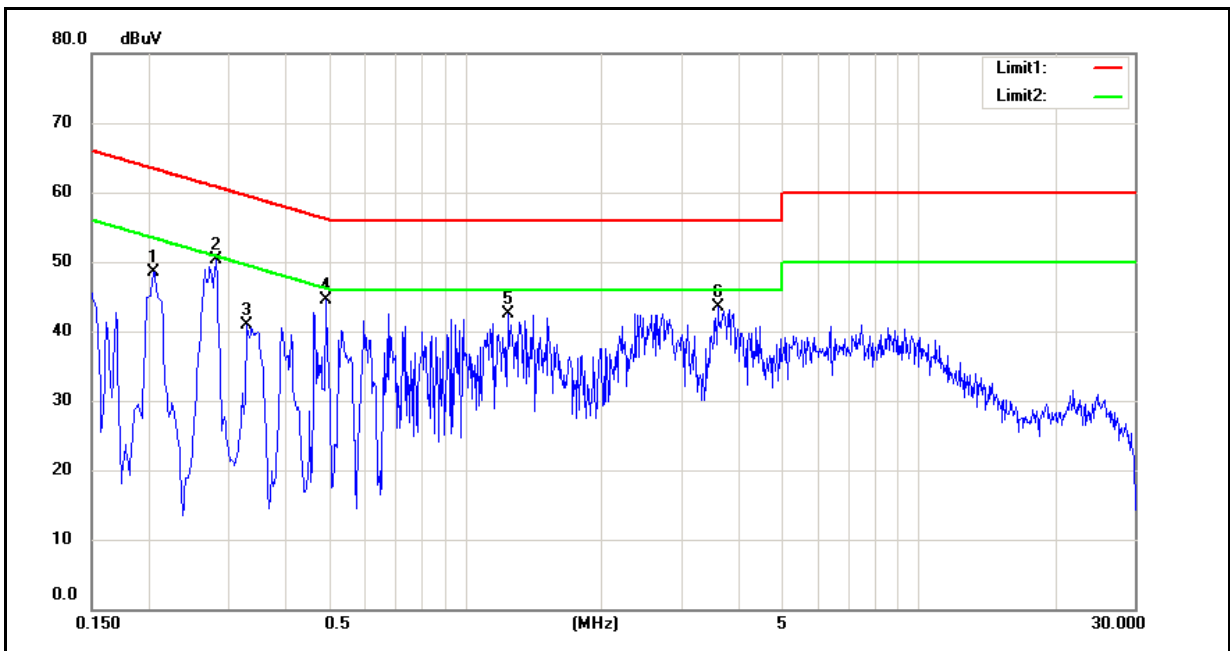

No.	Frequency (MHz)	QP reading (dBuV)	AVG reading (dBuV)	Correction factor (dB)	QP result (dBuV)	AVG result (dBuV)	QP limit (dBuV)	AVG limit (dBuV)	QP margin (dB)	AVG margin (dB)	Remark
1	0.2060	36.88	24.45	10.08	46.96	34.53	63.37	53.37	-16.41	-18.84	Pass
2	0.2820	37.08	23.50	10.05	47.13	33.55	60.76	50.76	-13.63	-17.21	Pass
3	0.3300	29.62	16.74	10.03	39.65	26.77	59.45	49.45	-19.80	-22.68	Pass
4	0.4940	29.52	13.44	9.96	39.48	23.40	56.10	46.10	-16.62	-22.70	Pass
5	1.2460	24.42	11.66	9.65	34.07	21.31	56.00	46.00	-21.93	-24.69	Pass
6	3.6140	28.36	15.67	9.84	38.20	25.51	56.00	46.00	-17.80	-20.49	Pass

Standard:	FCC Part 15C	Line:	N
Test item:	Conducted Emission	Power:	AC 120V/60Hz
Model:	OT-200	Temp.(°C)/Hum.(%RH):	26(°C)/60%RH
Mode:	Mode 2	Date:	2010/06/17
		Test By:	Gary Wu
Description:			

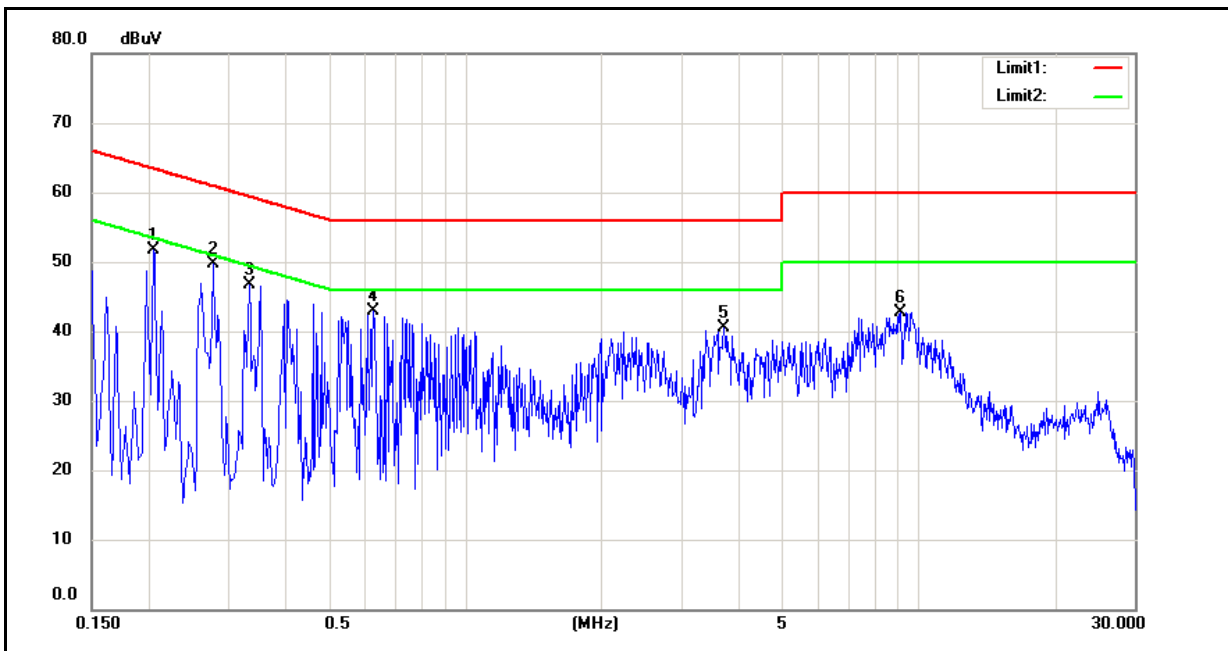

No.	Frequency (MHz)	QP reading (dBuV)	AVG reading (dBuV)	Correction factor (dB)	QP result (dBuV)	AVG result (dBuV)	QP limit (dBuV)	AVG limit (dBuV)	QP margin (dB)	AVG margin (dB)	Remark
1	0.2060	39.23	22.26	10.07	49.30	32.33	63.37	53.37	-14.07	-21.04	Pass
2	0.2780	36.79	21.75	10.04	46.83	31.79	60.88	50.88	-14.05	-19.09	Pass
3	0.3340	33.54	16.71	10.03	43.57	26.74	59.35	49.35	-15.78	-22.61	Pass
4	0.6300	28.07	12.04	9.90	37.97	21.94	56.00	46.00	-18.03	-24.06	Pass
5	3.7340	23.50	10.63	9.83	33.33	20.46	56.00	46.00	-22.67	-25.54	Pass
6	9.1180	24.43	10.95	10.11	34.54	21.06	60.00	50.00	-25.46	-28.94	Pass

5 Radiated Interference Measurement

5.1. Limit

Frequency Range (MHz)	Peak (dBuV)
30 to 88	39
88 to 216	43.5
216 to 960	46.4
Above 960	49.5

5.2. Test Instruments

3 Meter Chamber					
Equipment	Manufacturer	Model Number	Serial Number	Cal. Date	Remark
RF Pre-selector	Agilent	N9039A	MY46520256	01/27/2009	(2)
Spectrum Analyzer	Agilent	E4446A	MY46180578	01/20/2009	(2)
Pre Amplifier	Agilent	8449B	3008A02237	02/24/2010	(1)
Pre Amplifier	Agilent	8447D	2944A10961	02/24/2010	(1)
Bi-log Antenna	SCHWARZBECK MESS-ELEKTRONIK	VULB9163	9163-270	06/23/2009	(2)
Horn Antenna	SCHWARZBECK MESS-ELEKTRONIK	BBHA9120D	9120D-550	07/01/2009	(2)
Horn Antenna	SCHWARZBECK MESS-ELEKTRONIK	BBHA9170	9170-320	06/30/2009	(2)
Test Site	ATL	TE01	888001	08/06/2009	(1)

Remark: ⁽¹⁾ Calibration period 1 year. ⁽²⁾ Calibration period 2 years.

NOTE: N.C.R. = No Calibration Request.

5.3. Setup

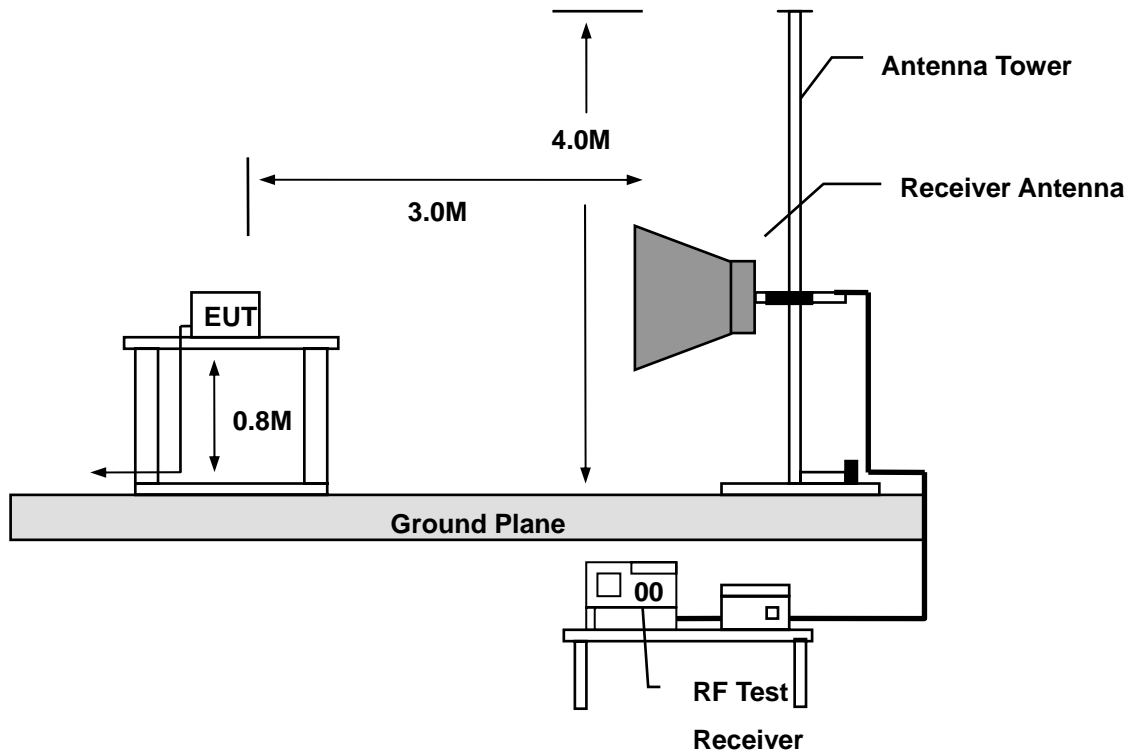

5.4. Test Procedure

Final radiation measurements were made on a three-meter, Semi Anechoic Chamber. The EUT system was placed on a nonconductive turntable which is 0.8 meters height, top surface 1.0 x 1.5 meter. The spectrum was examined from 250 MHz to 2.5 GHz in order to cover the whole spectrum below 10th harmonic which could generate from the EUT. During the test, EUT was set to transmit continuously & Measurements spectrum range from 30 MHz to 26.5 GHz is investigated.

For measurements below 1 GHz the resolution bandwidth is set to 100 kHz for peak detection measurements or 120 kHz for quasi-peak detection measurements. Peak detection is used unless otherwise noted as quasi-peak.

For measurements above 1 GHz the resolution bandwidth is set to 1 MHz, and then the video bandwidth is set to 1 MHz for peak measurements and 10 Hz for average measurements.

A nonconductive material surrounded the EUT to supporting the EUT for standing on three orthogonal planes. At each condition, the EUT was rotated 360 degrees, and the antenna was raised and lowered from one to four meters to find the maximum emission levels. Measurements were taken using both horizontal and vertical antenna polarization.

SCHWARZBECK MESS-ELEKTRONIK Biconilog Antenna (mode VULB9163) at 3 Meter and the SCHWARZBECK Double Ridged Guide Antenna (model BBHA9120D&9170) was used in frequencies 1 – 26.5 GHz at a distance of 1 meter. All test results were extrapolated to equivalent signal at 3 meters utilizing an inverse linear distance extrapolation Factor (20dB/decade).

For testing above 1GHz, the emission level of the EUT in peak mode was 20dB lower than average limit (that means the emission level in peak mode also complies with the limit in average mode), then testing will be stopped and peak values of EUT will be reported, otherwise, the emissions will be measured in average mode again and reported.

Appropriate preamplifiers were used for improving sensitivity and precautions were taken to avoid overloading or desensitizing the spectrum analyzer. No post – detector video filters were used in the test.

The spectrum analyzer's 6 dB bandwidth was set to 1 MHz, and the analyzer was operated in the peak detection mode, for frequencies both below and up 1 GHz. The average levels were obtained by subtracting the duty cycle correction factor from the peak readings.

The following procedures were used to convert the emission levels measured in decibels referenced to 1 microvolt (dBuV) into field intensity in micro volts per meter (uV/m).

The actual field intensity in decibels referenced to 1 microvolt in to field intensity in micro volts per meter (dBuV/m).

The actual field intensity in decibels referenced to 1 microvolt per meter (dBuV/m) is determined by algebraically adding the measured reading in dBuV, the antenna factor (dB), and cable loss (dB) and Subtracting the gain of preamplifier (dB) is auto calculate in spectrum analyzer.

$$(1) \text{ Amplitude (dBuV/m) = FI (dBuV) +AF (dBuV) +CL (dBuV)-Gain (dB)}$$

FI= Reading of the field intensity.

AF= Antenna factor.

CL= Cable loss.

P.S Amplitude is auto calculate in spectrum analyzer.

$$(2) \text{ Actual Amplitude (dBuV/m) = Amplitude (dBuV)-Dis(dB)}$$

The FCC specified emission limits were calculated according the EUT operating frequency and by following linear interpolation equations:

(a) For fundamental frequency : Transmitter Output < +30dBm

(b) For spurious frequency : Spurious emission limits = fundamental emission limit /10

5.5. Test Result

5.5.1. Below 1GHz

Standard:	FCC Part 15C	Test Distance:	3m
Test item:	Radiated Emission	Power:	AC 120V/60Hz
Model:	OT-200	Temp.(°C)/Hum.(%RH):	26(°C)/60%RH
Mode:	Mode 2	Date:	2010/06/20
Ant.Polar.:	Horizontal	Test By:	Gary Wu

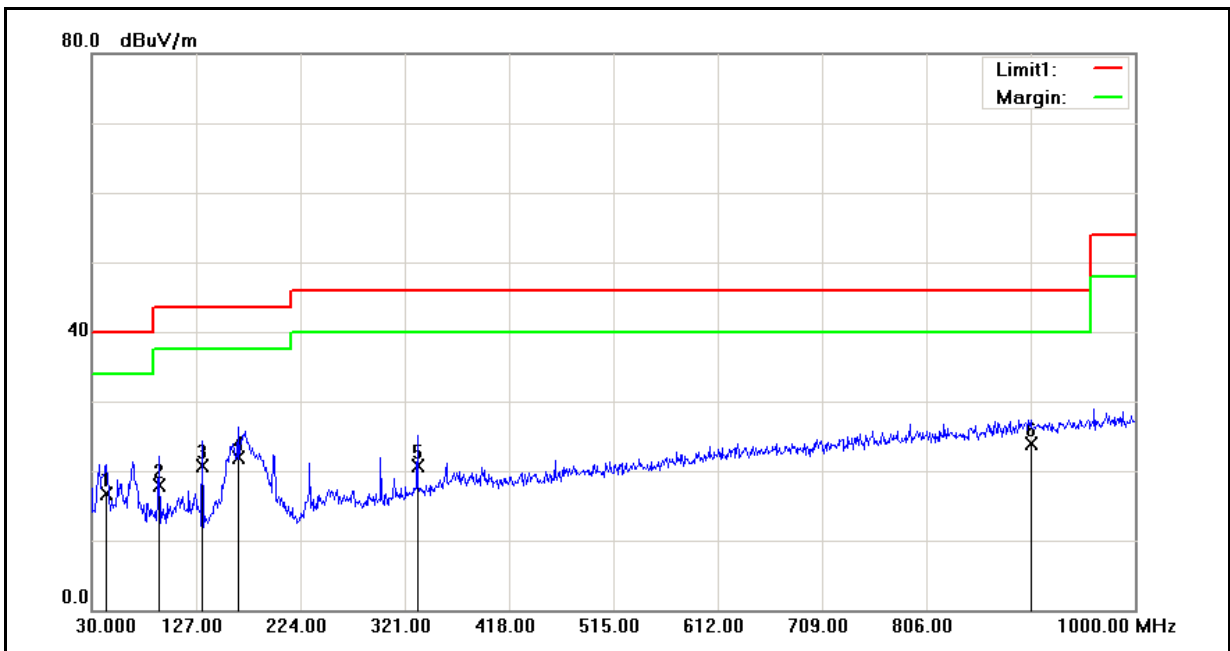

No.	Frequency (MHz)	Reading (dBuV)	Correct Factor(dB/m)	Result (dBuV/m)	Limit (dBuV/m)	Margin (dB)	Remark
1	43.5800	28.36	-11.74	16.62	40.00	-23.38	QP
2	92.5650	33.15	-15.29	17.86	43.50	-25.64	QP
3	132.8200	37.56	-16.84	20.72	43.50	-22.78	QP
4	166.2850	37.45	-15.60	21.85	43.50	-21.65	QP
5	332.6400	30.12	-9.37	20.75	46.00	-25.25	QP
6	903.4850	23.64	0.36	24.00	46.00	-22.00	QP

Standard:	FCC Part 15C	Test Distance:	3m
Test item:	Radiated Emission	Power:	AC 120V/60Hz
Model:	OT-200	Temp.(°C)/Hum.(%RH):	26(°C)/60%RH
Mode:	Mode 2	Date:	2010/06/20
Ant.Polar.:	Vertical	Test By:	Gary Wu

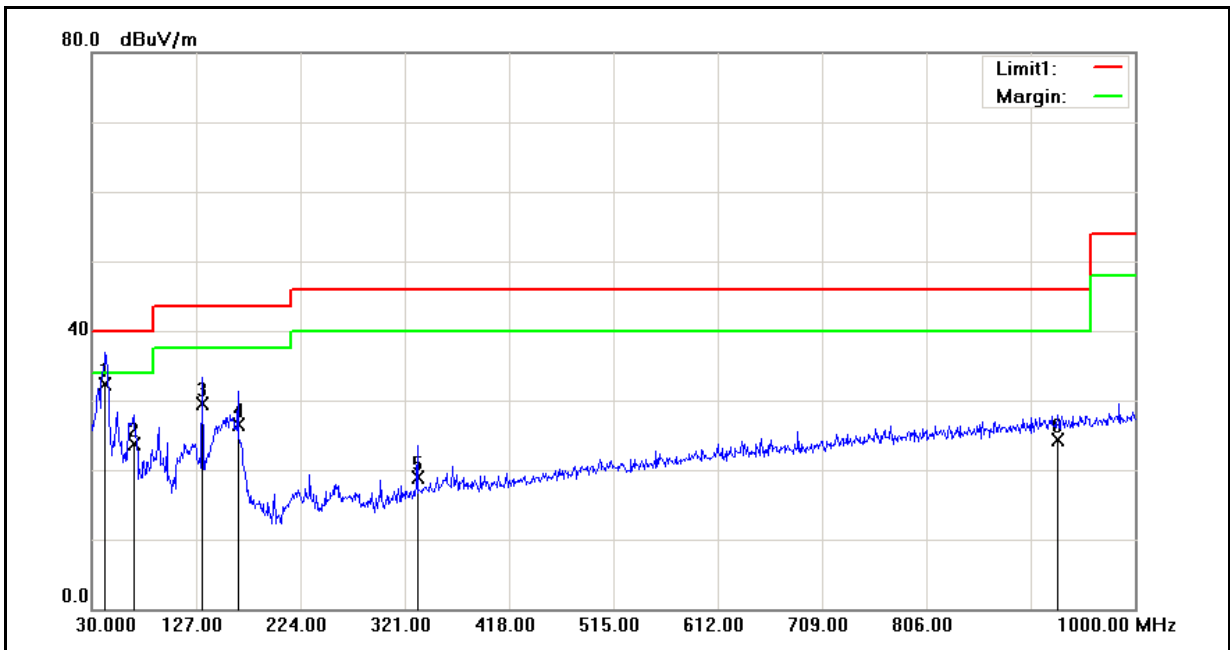

No.	Frequency (MHz)	Reading (dBuV)	Correct Factor(dB/m)	Result (dBuV/m)	Limit (dBuV/m)	Margin (dB)	Remark
1	42.6100	44.21	-11.83	32.38	40.00	-7.62	QP
2	68.8000	39.36	-15.68	23.68	40.00	-16.32	QP
3	132.8200	46.25	-16.84	29.41	43.50	-14.09	QP
4	166.2850	42.12	-15.60	26.52	43.50	-16.98	QP
5	332.6400	28.34	-9.37	18.97	46.00	-27.03	QP
6	928.7050	23.64	0.65	24.29	46.00	-21.71	QP

5.5.2. Above 1GHz

Standard:		FCC Part 15C		Test Distance:		3m	
Test item:		Radiated Emission		Power:		AC 120V/60Hz	
Model:		OT-200		Temp.(°C)/Hum.(%RH):		26(°C)/60%RH	
Mode:		Mode 3		Date:		2010/06/20	
Frequency:		2402 MHz		Test By:		Gary Wu	
Frequency (MHz)	Reading (dBuV)	Correct Factor(dB/m)	Result (dBuV/m)	Limit (dBuV/m)	Margin (dB)	Remark	Ant.Polar. H / V
4804.000	43.42	7.74	51.16	74.00	-22.84	peak	H
7206.000	34.68	15.30	49.98	74.00	-24.02	peak	H
4804.000	42.88	7.74	50.62	74.00	-23.38	peak	V
7206.000	34.80	15.30	50.10	74.00	-23.90	peak	V

Standard:		FCC Part 15C		Test Distance:		3m	
Test item:		Radiated Emission		Power:		AC 120V/60Hz	
Model:		OT-200		Temp.(°C)/Hum.(%RH):		26(°C)/60%RH	
Mode:		Mode 3		Date:		2010/06/20	
Frequency:		2441 MHz		Test By:		Gary Wu	
Frequency (MHz)	Reading (dBuV)	Correct Factor(dB/m)	Result (dBuV/m)	Limit (dBuV/m)	Margin (dB)	Remark	Ant.Polar. H / V
4882.000	47.98	7.96	55.94	74.00	-18.06	peak	H
4882.000	32.11	7.96	40.07	54.00	-13.93	AVG	H
7323.000	34.56	15.63	50.19	74.00	-23.81	peak	H
4882.000	46.85	7.96	54.81	74.00	-19.19	peak	V
4882.000	32.26	7.96	40.22	54.00	-13.78	AVG	V
7323.000	33.75	15.63	49.38	74.00	-24.62	peak	V

Standard:	FCC Part 15C			Test Distance:	3m		
Test item:	Radiated Emission			Power:	AC 120V/60Hz		
Model:	OT-200			Temp.(°C)/Hum.(%RH):	26(°C)/60%RH		
Mode:	Mode 3			Date:	2010/06/20		
Frequency:	2480 MHz			Test By:	Gary Wu		
Frequency (MHz)	Reading (dBuV)	Correct Factor(dB/m)	Result (dBuV/m)	Limit (dBuV/m)	Margin (dB)	Remark	Ant.Polar. H / V
4960.000	51.45	8.18	59.63	74.00	-14.37	peak	H
4960.000	33.75	8.18	41.93	54.00	-12.07	AVG	H
7440.000	34.79	15.96	50.75	74.00	-23.25	peak	H
4960.000	51.40	8.18	59.58	74.00	-14.42	peak	V
4960.000	33.71	8.18	41.89	54.00	-12.11	AVG	V
7440.000	34.37	15.96	50.33	74.00	-23.67	peak	V

Standard:	FCC Part 15C			Test Distance:	3m		
Test item:	Radiated Emission			Power:	AC 120V/60Hz		
Model:	OT-200			Temp.(°C)/Hum.(%RH):	26(°C)/60%RH		
Mode:	Mode 5			Date:	2010/06/20		
Frequency:	2402 MHz			Test By:	Gary Wu		
Frequency (MHz)	Reading (dBuV)	Correct Factor(dB/m)	Result (dBuV/m)	Limit (dBuV/m)	Margin (dB)	Remark	Ant.Polar. H / V
4804.000	38.02	7.74	45.76	74.00	-28.24	peak	H
7206.000	34.72	15.30	50.02	74.00	-23.98	peak	H
4804.000	37.82	7.74	45.56	74.00	-28.44	peak	V
7206.000	36.29	15.30	51.59	74.00	-22.41	peak	V

Standard:	FCC Part 15C			Test Distance:	3m		
Test item:	Radiated Emission			Power:	AC 120V/60Hz		
Model:	OT-200			Temp.(°C)/Hum.(%RH):	26(°C)/60%RH		
Mode:	Mode 5			Date:	2010/06/20		
Frequency:	2441 MHz			Test By:	Gary Wu		
Frequency (MHz)	Reading (dBuV)	Correct Factor(dB/m)	Result (dBuV/m)	Limit (dBuV/m)	Margin (dB)	Remark	Ant.Polar. H / V
4882.000	41.56	7.96	49.52	74.00	-24.48	peak	H
7323.000	34.74	15.63	50.37	74.00	-23.63	peak	H
4882.000	42.01	7.96	49.97	74.00	-24.03	peak	V
7323.000	35.53	15.63	51.16	74.00	-22.84	peak	V

Standard:	FCC Part 15C			Test Distance:	3m		
Test item:	Radiated Emission			Power:	AC 120V/60Hz		
Model:	OT-200			Temp.(°C)/Hum.(%RH):	26(°C)/60%RH		
Mode:	Mode 5			Date:	2010/06/20		
Frequency:	2480 MHz			Test By:	Gary Wu		
Frequency (MHz)	Reading (dBuV)	Correct Factor(dB/m)	Result (dBuV/m)	Limit (dBuV/m)	Margin (dB)	Remark	Ant.Polar. H / V
4960.000	45.46	8.18	53.64	74.00	-20.36	peak	H
4960.000	30.95	8.18	39.13	54.00	-14.87	AVG	H
7440.000	32.78	15.96	48.74	74.00	-25.26	peak	H
4960.000	44.43	8.18	52.61	74.00	-21.39	peak	V
4960.000	30.83	8.18	39.01	54.00	-14.99	AVG	V
7440.000	34.53	15.96	50.49	74.00	-23.51	peak	V

Standard:	FCC Part 15C	Test Distance:	3m
Test item:	Radiated Emission	Power:	AC 120V/60Hz
Model:	OT-200	Temp.(°C)/Hum.(%RH):	26(°C)/60%RH
Mode:	Mode 6	Date:	2010/06/20
Frequency:	2441 MHz	Test By:	Gary Wu

Frequency (MHz)	Reading (dBuV)	Correct Factor(dB/m)	Result (dBuV/m)	Limit (dBuV/m)	Margin (dB)	Remark	Ant.Polar. H / V
2725.500	40.06	1.07	41.13	74.00	-32.87	peak	H
6600.000	35.37	13.26	48.63	74.00	-25.37	peak	H
2736.000	41.30	1.11	42.41	74.00	-31.59	peak	V
6729.500	35.64	13.73	49.37	74.00	-24.63	peak	V

6 Maximum Conducted Output Power Measurement

6.1. Limit

For frequency hopping systems operating in the 2400–2483.5 MHz band employing at least 75 non-overlapping hopping channels < 1 watt.

6.2. Test Setup

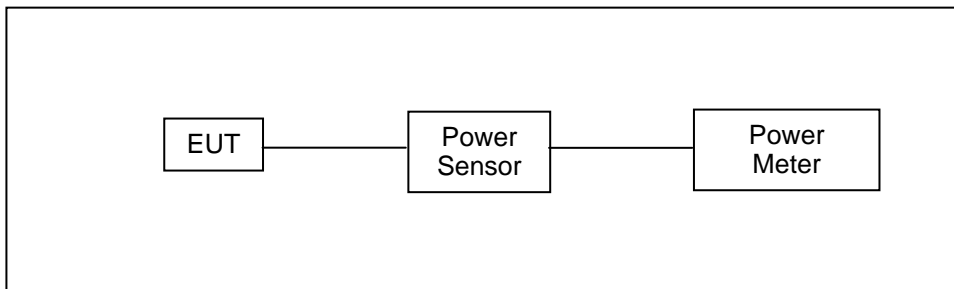

6.3. Test Instruments

Equipment	Manufacturer	Model Number	Serial Number	Cal. Date	Remark
Single Channel PK Power Sensor	Agilent	N1911A	MY15101619	07/14/2009	(1)
Wideband Power Meter	Agilent	N1921A	MY45241957	07/25/2009	(1)
Test Site	ATL	TE06	TE06	N.C.R.	-----

Remark: ⁽¹⁾ Calibration period 1 year. ⁽²⁾ Calibration period 2 years.

NOTE: N.C.R. = No Calibration Request.

6.4. Test Procedure

The tests below are run with the EUT's transmitter set at high power in TX mode. The EUT is needed to force selection of output power level and channel number. While testing, EUT was set to transmit continuously. Remove the Subjective device's antenna and connect the RF output port to power sensor. The maximum peak output power shall not exceed 1 watt.

Use a direct connection between the antenna port of transmitter and the power sensor, for prevent the power sensor input attenuation 40-50 dB. Set the RBW Bandwidth of the emission or use a channel power meter mode.

For antennas with gains of 6 dBi or less, maximum allowed transmitter output is 1 watt (+30 dBm). For antennas with gains greater than 6 dBi, transmitter output level must be decreased by an amount equal to (GAIN - 6)/3 dBm.

The antenna port of the EUT was connected to the input of a power sensor. Power was read directly and cable loss correction was added to the reading to obtain power at the EUT antenna terminals.

6.5. Test Result

Model	OT-200					
Test Item	Maximum Conducted Output Power					
Test Mode	Mode 3: GFSK Link Mode					
Date of Test	06/22/2010			Test Site	TE06	
Frequency (MHz)	Packet Type	Average Power		Peak Power		Limit (W)
		(dBm)	(W)	(dBm)	(W)	
2402	DH1	-2.04	0.00063	3.44	0.00221	< 1
	DH3	1.14	0.00130	3.42	0.00220	< 1
	DH5	1.82	0.00152	3.35	0.00216	< 1
2441	DH1	-2.26	0.00059	3.03	0.00201	< 1
	DH3	0.91	0.00123	3.08	0.00203	< 1
	DH5	1.59	0.00144	3.09	0.00204	< 1
2480	DH1	-3.60	0.00044	1.74	0.00149	< 1
	DH3	-0.43	0.00091	1.73	0.00149	< 1
	DH5	0.25	0.00106	1.73	0.00149	< 1

Model	OT-200					
Test Item	Maximum Conducted Output Power					
Test Mode	Mode 4: $\pi/4$ -DQPSK Mode					
Date of Test	06/22/2010			Test Site	TE06	
Frequency (MHz)	Packet Type	Average Power		Peak Power		Limit (W)
		(dBm)	(W)	(dBm)	(W)	
2402	DH1	-2.81	0.00052	3.76	0.00238	< 1
	DH3	-0.05	0.00099	3.83	0.00242	< 1
	DH5	0.57	0.00114	3.81	0.00240	< 1
2441	DH1	-3.31	0.00047	3.39	0.00218	< 1
	DH3	-0.57	0.00088	3.40	0.00219	< 1
	DH5	0.04	0.00101	3.33	0.00215	< 1
2480	DH1	-4.81	0.00033	1.98	0.00158	< 1
	DH3	-2.10	0.00062	2.00	0.00158	< 1
	DH5	-1.47	0.00071	2.01	0.00159	< 1

Model	OT-200					
Test Item	Maximum Conducted Output Power					
Test Mode	Mode 5: 8DPSK Link Mode					
Date of Test	06/22/2010			Test Site	TE06	
Frequency (MHz)	Packet Type	Average Power		Peak Power		Limit (W)
		(dBm)	(W)	(dBm)	(W)	
2402	DH1	-2.82	0.00052	3.89	0.00245	< 1
	DH3	-0.08	0.00098	3.82	0.00241	< 1
	DH5	0.53	0.00113	3.82	0.00241	< 1
2441	DH1	-3.32	0.00047	3.42	0.00220	< 1
	DH3	-0.59	0.00087	3.40	0.00219	< 1
	DH5	0.03	0.00101	3.44	0.00221	< 1
2480	DH1	-4.79	0.00033	2.11	0.00163	< 1
	DH3	-2.09	0.00062	1.99	0.00158	< 1
	DH5	-1.47	0.00071	2.04	0.00160	< 1

7 Minimum 20dB RF Bandwidth Measurement

7.1. Limit

N/A

7.2. Test Setup

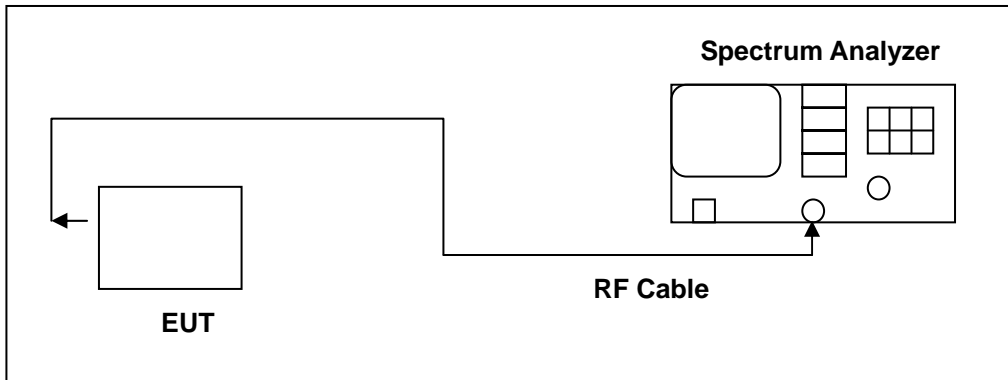

7.3. Test Instruments

Equipment	Manufacturer	Model Number	Serial Number	Cal. Date	Remark
Spectrum Analyzer	Agilent	E4445A	MY46181986	05/14/2009	⁽²⁾
Test Site	ATL	TE06	TE06	N.C.R.	-----

Remark: ⁽¹⁾ Calibration period 1 year. ⁽²⁾ Calibration period 2 years.

NOTE: N.C.R. = No Calibration Request.

7.4. Test Procedure

The RF output port of the Equipment-Under-Test is directly coupled to the input of the EMC analyzer through a specialized RF connector and a 10dB passive attenuator. A fully charged battery was used for the supply voltage. The Bluetooth frequency hopping function of the EUT was enabled. The spectrum analyzer used the following settings:

1. Span = approx. 2 to 3 times the 20dB bandwidth, centered on a hopping frequency
2. RBW \geq 1% of the 20dB span
3. VBW \geq RBW
4. Sweep = auto
5. Detector function = peak
6. Trace = max hold

The trace was allowed to stabilize. The EUT was transmitting at its maximum data rate. The marker-to-peak function was used to set the marker to the peak of the emission. The marker-delta function was used to measure 20dB down one side of the emission. The marker-delta function and marker was moved to the other side of the emission until it was even with the reference marker. The marker-delta reading at this point was the 20dB bandwidth of the emission.

7.5. Test Result

Model	OT-200		
Test Item	Minimum 20dB RF Bandwidth		
Test Mode	Mode 3: GFSK Link Mode		
Date of Test	06/22/2010	Test Site	TE06
Frequency (MHz)	Measurement (MHz)		Limit (MHz)
2402	0.93000		-----
2441	0.93000		-----
2480	0.93375		-----

Model	OT-200		
Test Item	Minimum 20dB RF Bandwidth		
Test Mode	Mode 5: 8DPSK Link Mode		
Date of Test	06/22/2010	Test Site	TE06
Frequency (MHz)	20dB Bandwidth (MHz)		Limit (MHz)
2402	1.26750		-----
2441	1.26750		-----
2480	1.30500		-----

7.6. Test Graphs

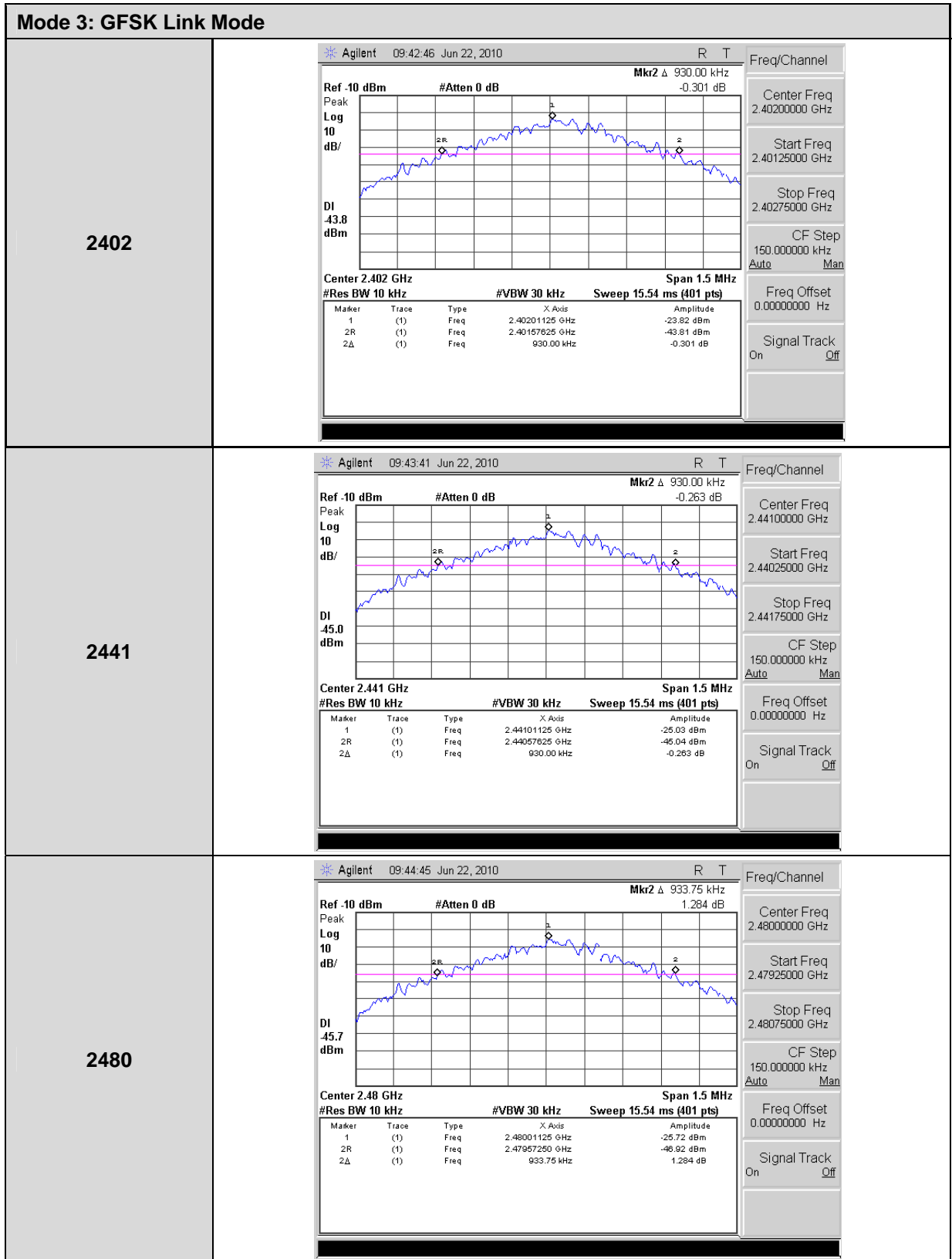

Mode 5: 8DPSK Link Mode

<p>2402</p>	
<p>2441</p>	
<p>2480</p>	

8 Carrier Frequency Separation Measurement

8.1. Limit

Title 47 of the CFR: 2002, Part 15 Subpart (c) 15.247(a)(1)(i) requires the measurement of the bandwidth of the transmission between the -20 dB points on the transmitted spectrum. The results of this test determine the limits for channel spacing. The channel spacing shall be a minimum of 25 kHz or the 20 dB bandwidth.

8.2. Test Setup

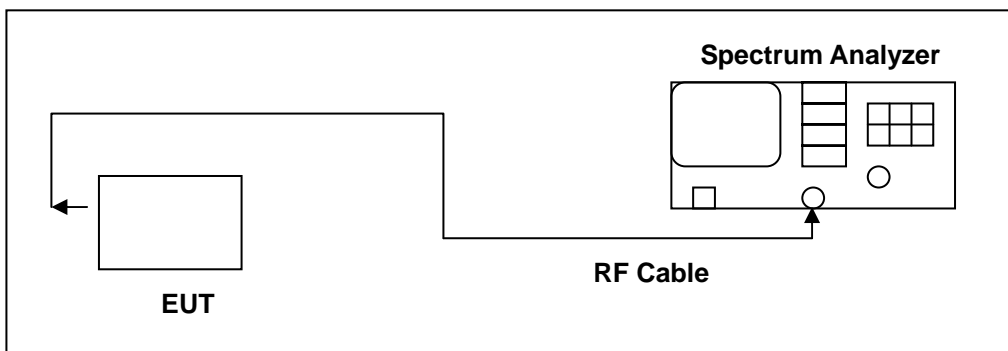

8.3. Test Instruments

Equipment	Manufacturer	Model Number	Serial Number	Cal. Date	Remark
Spectrum Analyzer	Agilent	E4445A	MY46181986	05/14/2009	⁽²⁾
Test Site	ATL	TE06	TE06	N.C.R.	-----

Remark: ⁽¹⁾ Calibration period 1 year. ⁽²⁾ Calibration period 2 years.

NOTE: N.C.R. = No Calibration Request.

8.4. Test Procedure

The RF output port of the Equipment-Under-Test is directly coupled to the input of the EMC analyzer through a specialized RF connector and a 10dB passive attenuator. A fully charged battery was used for the supply voltage. The Bluetooth transmitter of the V6 had its hopping function enabled. The following spectrum analyzer settings were used:

1. Span = wide enough to capture the peaks of two adjacent channels
2. Resolution (or IF) Bandwidth (RBW) \geq 1% of the span
3. Video (or Average) Bandwidth (VBW) \geq RBW
4. Sweep = auto
5. Detector function = peak
6. Trace = max hold

The trace was allowed to stabilize. The marker-delta function was used to determine the separation between the peaks of the adjacent channels.

8.5. Test Result

Model	OT-200		
Test Item	Carrier Frequency Separation		
Test Mode	Mode 3: GFSK Link Mode		
Date of Test	06/22/2010	Test Site	TE06
Frequency (MHz)	Measurement (MHz)		Limit (MHz)
2441	1		minimum of 25 kHz or the 20 dB bandwidth

Model	OT-200		
Test Item	Carrier Frequency Separation		
Test Mode	Mode 5: 8DPSK Link Mode		
Date of Test	06/22/2010	Test Site	TE06
Frequency (MHz)	Measurement (MHz)		Limit (MHz)
2441	1		minimum of 25 kHz or the 20 dB bandwidth

8.6. Test Graphs

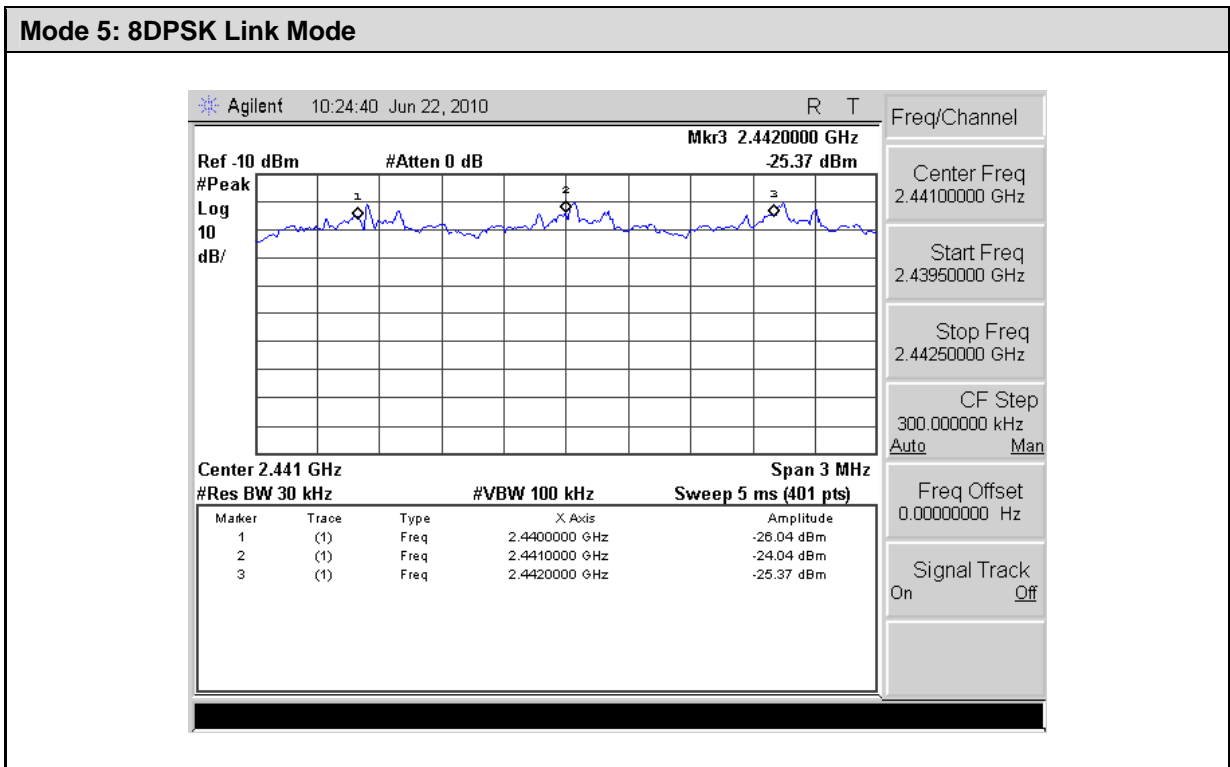
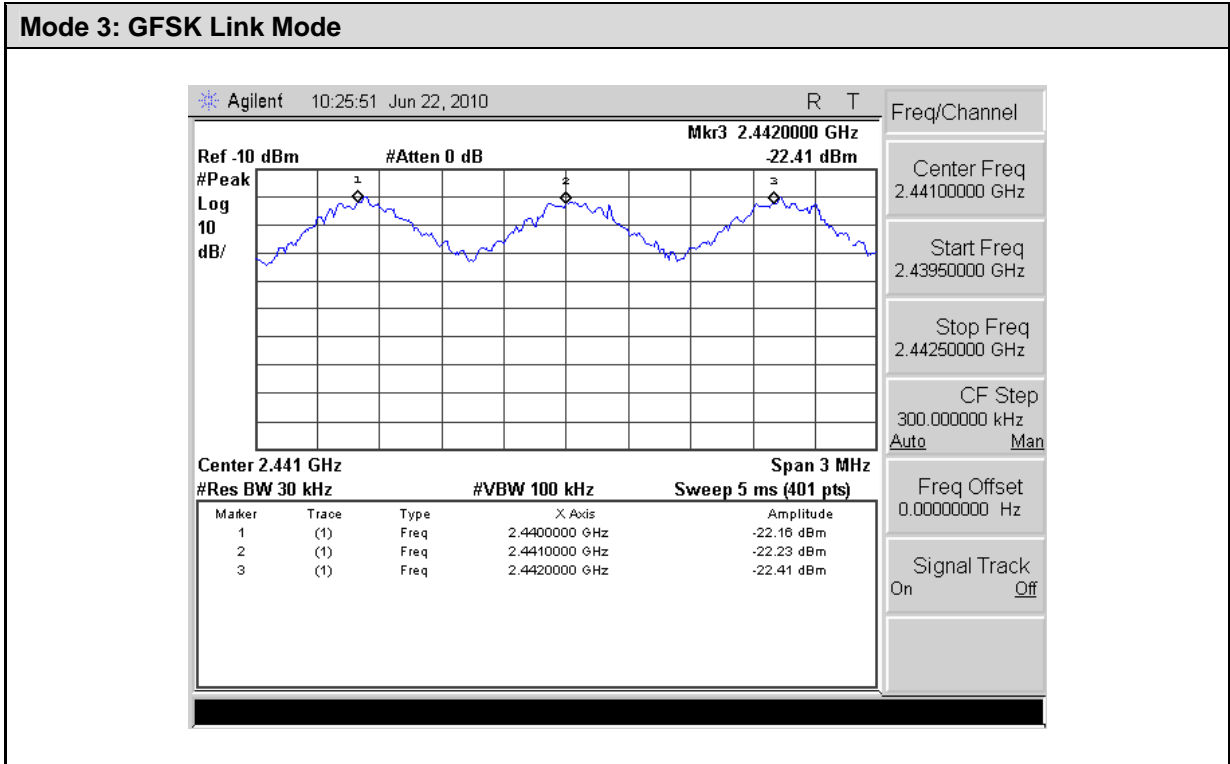

9 Number of Hopping Measurement

9.1. Limit

Frequency hopping systems in the 2400–2483.5 MHz band shall use at least 15 channels.

9.2. Test Setup

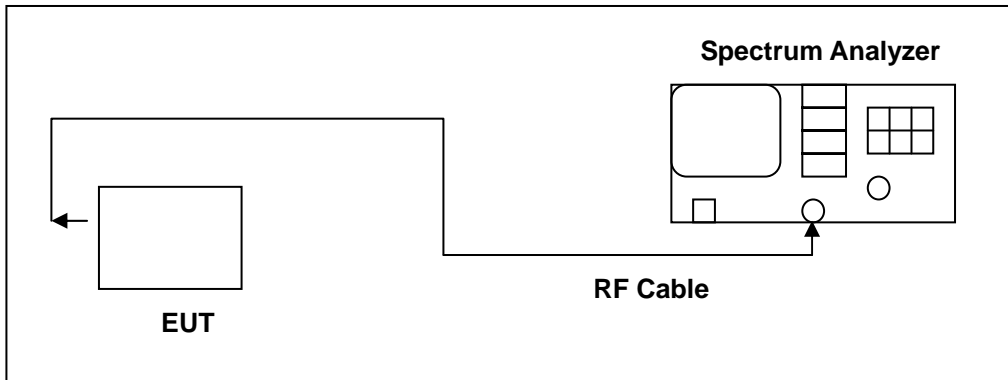

9.3. Test Instruments

Equipment	Manufacturer	Model Number	Serial Number	Cal. Date	Remark
Spectrum Analyzer	Agilent	E4445A	MY46181986	05/14/2009	⁽²⁾
Test Site	ATL	TE06	TE06	N.C.R.	-----

Remark: ⁽¹⁾ Calibration period 1 year. ⁽²⁾ Calibration period 2 years.

NOTE: N.C.R. = No Calibration Request.

9.4. Test Procedure

The RF output port of the Equipment-Under-Test is directly coupled to the input of the EMC analyzer through a specialized RF connector and a 10dB passive attenuator. A fully charged battery was used for the supply voltage. The Bluetooth frequency hopping function of the EUT was enabled. The spectrum analyzer used the following settings:

1. Span = the frequency band of operation
2. RBW \geq 1% of the span
3. VBW \geq RBW
4. Sweep = auto
5. Detector function = peak
6. Trace = max hold

The trace was allowed to stabilize.

9.5. Test Result

Model	OT-200		
Test Item	Number of Hopping		
Test Mode	Mode 3: GFSK Link Mode		
Date of Test	06/22/2010	Test Site	TE06
Frequency Range (MHz)	Measurement (ch)		Limit (ch)
2402 - 2480	79		> 15

Model	OT-200		
Test Item	Number of Hopping		
Test Mode	Mode 5: 8DPSK Link Mode		
Date of Test	06/22/2010	Test Site	TE06
Frequency Range (MHz)	Measurement (ch)		Limit (ch)
2402 - 2480	79		> 15

9.6. Test Graphs

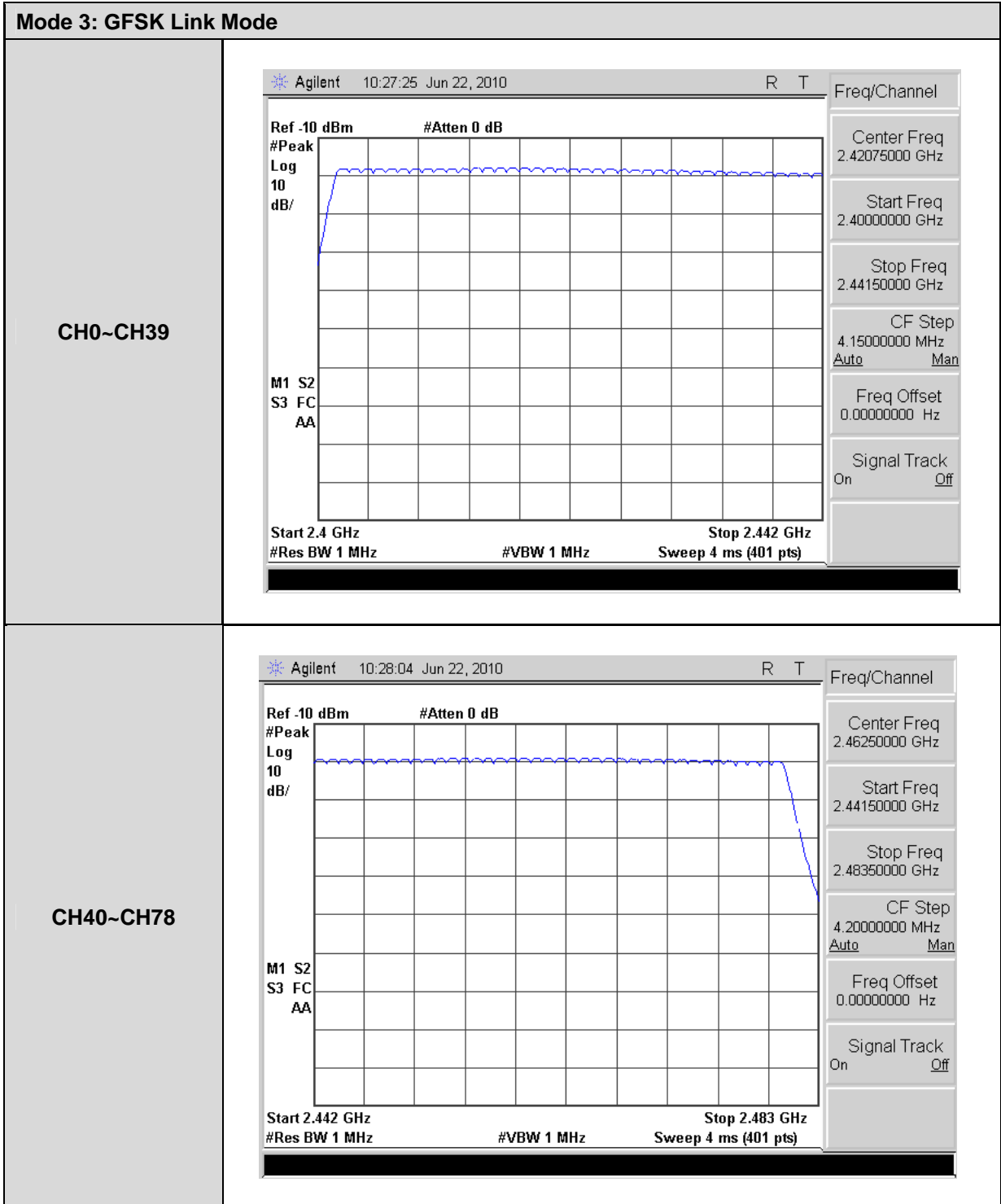

Mode 5: 8DPSK Link Mode

CH0~CH39

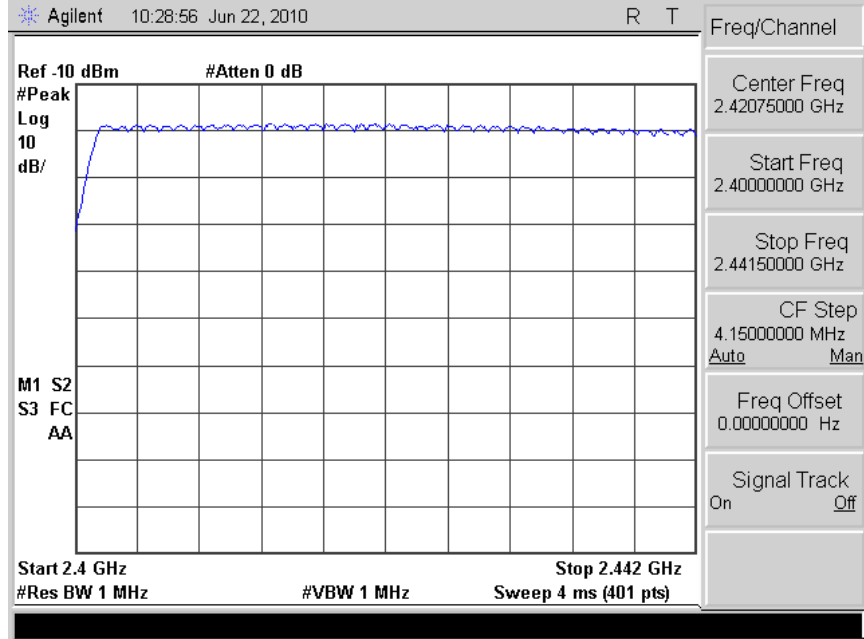

CH40~CH78

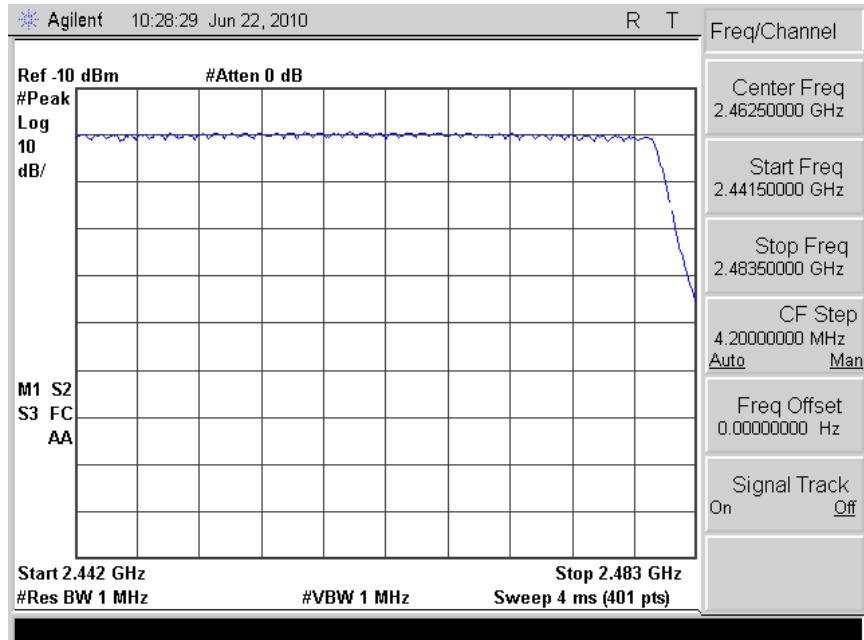

10 Time of Occupancy (Dwell Time) Measurement

10.1. Limit

The average time of occupancy on any channel shall not be greater than 0.4 seconds within a period of 0.4 seconds multiplied by the number of hopping channels employed.

10.2. Test Setup

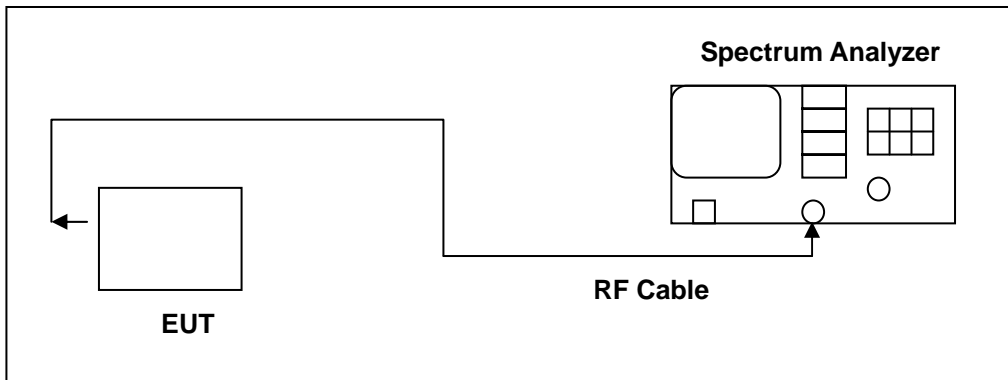

10.3. Test Instruments

Equipment	Manufacturer	Model Number	Serial Number	Cal. Date	Remark
Spectrum Analyzer	Agilent	E4445A	MY46181986	05/14/2009	⁽²⁾
Test Site	ATL	TE06	TE06	N.C.R.	-----

Remark: ⁽¹⁾ Calibration period 1 year. ⁽²⁾ Calibration period 2 years.

NOTE: N.C.R. = No Calibration Request.

10.4. Test Procedure

The RF output port of the Equipment-Under-Test is directly coupled to the input of the EMC analyzer through a specialized RF connector and a 10dB passive attenuator. A fully charged battery was used for the supply voltage. The Bluetooth hopping function of the EUT was enabled. The following spectrum analyzer settings were used:

1. Span = zero span, centered on a hopping channel
2. RBW = 1 MHz
3. VBW \geq RBW
4. Sweep = as necessary to capture the entire dwell time per hopping channel
5. Detector function = peak
6. Trace = max hold

The marker-delta function was used to determine the dwell time.

10.5. Test Result

Model	OT-200		
Test Item	Time of Occupancy (Dwell Time)		
Test Mode	Mode 3: GFSK Link Mode		
Date of Test	06/22/2010	Test Site	TE06
DH1			
Cycle Calculate	79CH * 0.4 = 31.6 (sec)		
The EUT Hopping Number per Sec	1600 times/sec		
Each Channel Dwell Times per Sec	800/79CH = 10.13(times/sec)		
Each Channel Dwell Times (1)	0.450	ms (sec)	
Each Channel Dwell Times on Cycle(2)	31.6 * 10.13 = 320.108(times)		
Dwell Times on Cycle (1) * (2)	144.0486	ms (sec)	
LIMIT(msec)	< = 400		
DH3			
Cycle Calculate	79CH * 0.4 = 31.6 (sec)		
The EUT Hopping Number per Sec	1600 times/sec		
Each Channel Dwell Times per Sec	400/79CH = 5.1(times/sec)		
Each Channel Dwell Times (1)	1.725	ms (sec)	
Each Channel Dwell Times on Cycle(2)	31.6 * 5.1 = 161.16(times)		
Dwell Times on Cycle (1) * (2)	278.0010	ms (sec)	
LIMIT(msec)	< = 400		
DH5			
Cycle Calculate	79CH * 0.4 = 31.6 (sec)		
The EUT Hopping Number per Sec	1600 times/sec		
Each Channel Dwell Times per Sec	266.7/79CH = 3.37(times/sec)		
Each Channel Dwell Times (1)	3.000	ms (sec)	
Each Channel Dwell Times on Cycle(2)	31.6 * 3.37 = 106.492(times)		
Dwell Times on Cycle (1) * (2)	319.4760	ms (sec)	
LIMIT(msec)	< = 400		

Model	OT-200		
Test Item	Time of Occupancy (Dwell Time)		
Test Mode	Mode 5: 8DPSK Link Mode		
Date of Test	06/22/2010	Test Site	TE06
3DH1			
Cycle Calculate	$79\text{CH} * 0.4 = 31.6 \text{ (sec)}$		
The EUT Hopping Number per Sec	1600 times/sec		
Each Channel Dwell Times per Sec	$800/79\text{CH} = 10.13(\text{times/sec})$		
Each Channel Dwell Times (1)	0.575 ms (sec)		
Each Channel Dwell Times on Cycle(2)	$31.6 * 10.13 = 320.108(\text{times})$		
Dwell Times on Cycle (1) * (2)	184.0621 ms (sec)		
LIMIT(msec)	< = 400		
3DH3			
Cycle Calculate	$79\text{CH} * 0.4 = 31.6 \text{ (sec)}$		
The EUT Hopping Number per Sec	1600 times/sec		
Each Channel Dwell Times per Sec	$400/79\text{CH} = 5.1(\text{times/sec})$		
Each Channel Dwell Times (1)	1.850 ms (sec)		
Each Channel Dwell Times on Cycle(2)	$31.6 * 5.1 = 161.16(\text{times})$		
Dwell Times on Cycle (1) * (2)	298.1460 ms (sec)		
LIMIT(msec)	< = 400		
3DH5			
Cycle Calculate	$79\text{CH} * 0.4 = 31.6 \text{ (sec)}$		
The EUT Hopping Number per Sec	1600 times/sec		
Each Channel Dwell Times per Sec	$266.7/79\text{CH} = 3.37(\text{times/sec})$		
Each Channel Dwell Times (1)	3.075 ms (sec)		
Each Channel Dwell Times on Cycle(2)	$31.6 * 3.37 = 106.492(\text{times})$		
Dwell Times on Cycle (1) * (2)	327.4629 ms (sec)		
LIMIT(msec)	< = 400		

10.6. Test Graphs

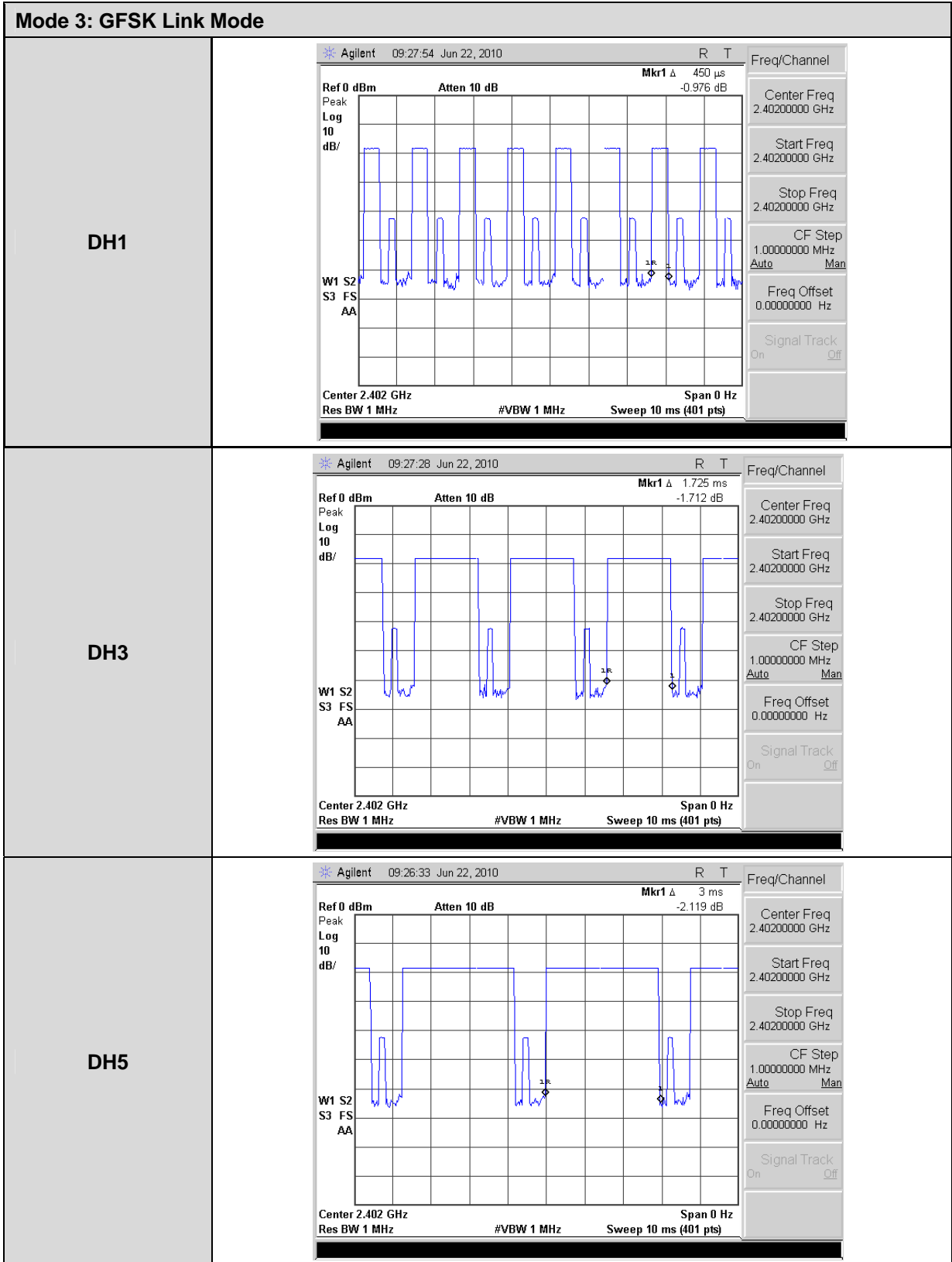

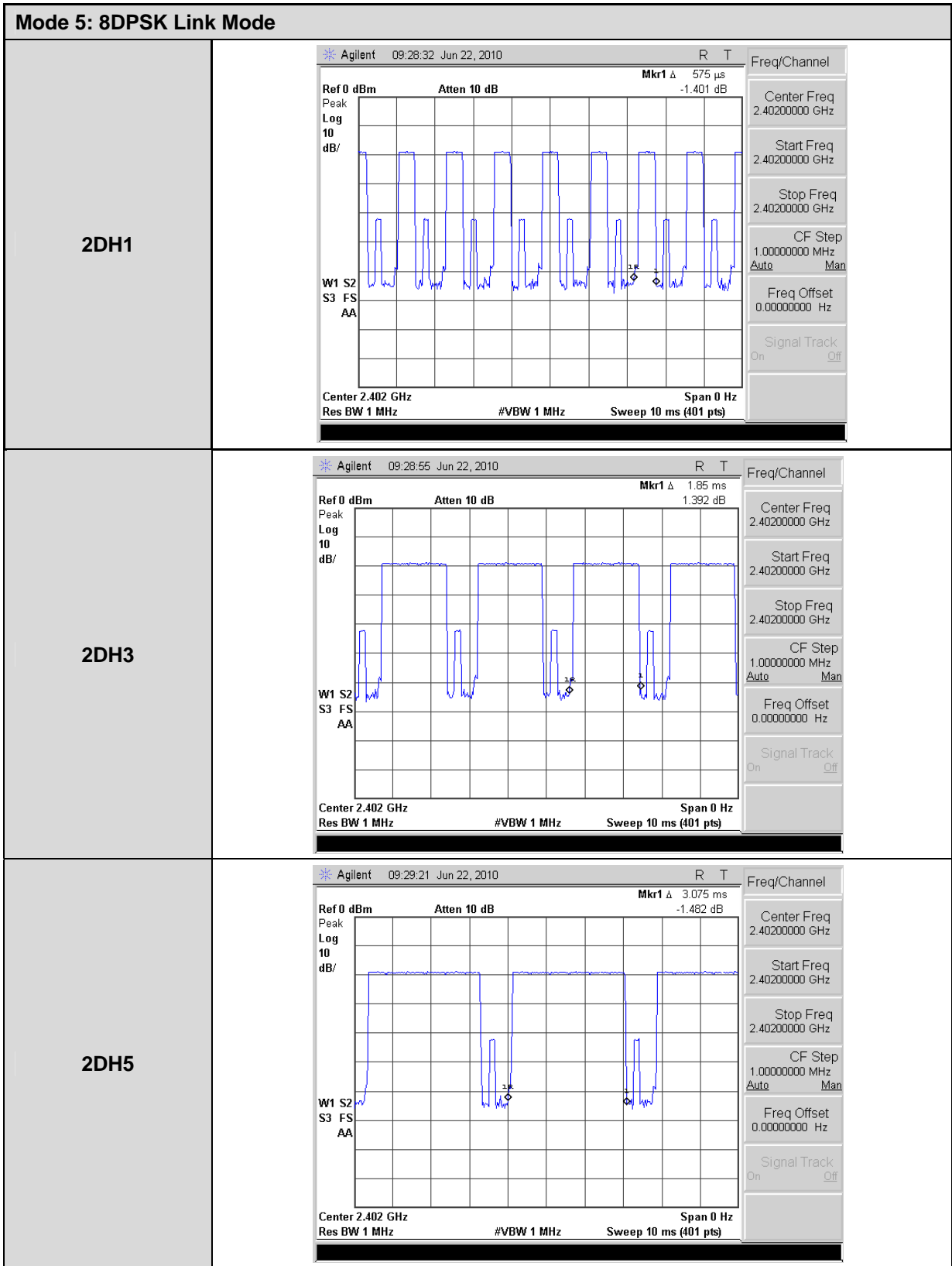

11 Out of Band Conducted Emissions Measurement

11.1. Limit

In any 100 kHz bandwidth outside the frequency band in which the spread spectrum or digitally modulated intentional radiator is operating, the radio frequency power that is produced by the intentional radiator shall be at least 20 dB below that in the 100 kHz bandwidth within the band that contains the highest level of the desired power

11.2. Test Setup

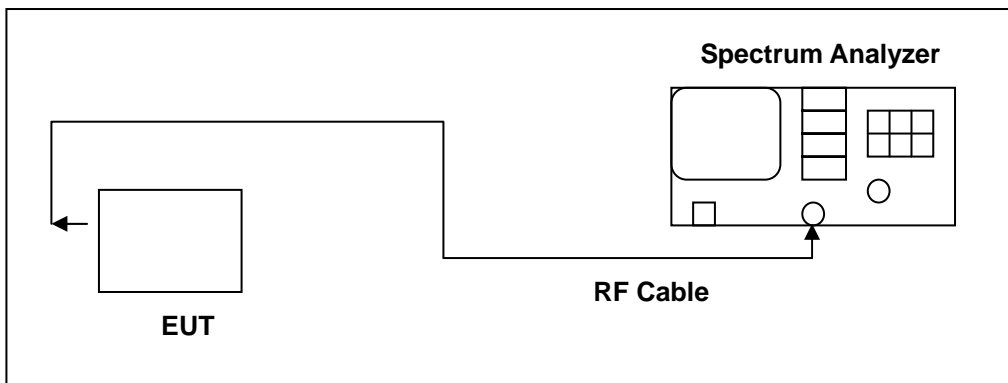

11.3. Test Instruments

Equipment	Manufacturer	Model Number	Serial Number	Cal. Date	Remark
Spectrum Analyzer	Agilent	E4445A	MY46181986	05/14/2009	⁽²⁾
Test Site	ATL	TE06	TE06	N.C.R.	-----

Remark: ⁽¹⁾ Calibration period 1 year. ⁽²⁾ Calibration period 2 years.

NOTE: N.C.R. = No Calibration Request.

11.4. Test Procedure

In any 100 kHz bandwidth outside the EUT pass band, the RF power produced by the modulation products of the spreading sequence, the information sequence, and the carrier frequency shall be at least 20 dB below that of the maximum in-band 100 kHz emission, antenna output of the EUT was coupled directly to spectrum analyzer; if an external attenuator and/or cable was used, these losses are compensated for with the analyzer OFFSET function.

All other types of emissions from the EUT shall meet the general limits for radiated frequencies outside the pass band. The test was performed at 3 channels (Channel 0, 39, 78)

11.5. Test Graphs

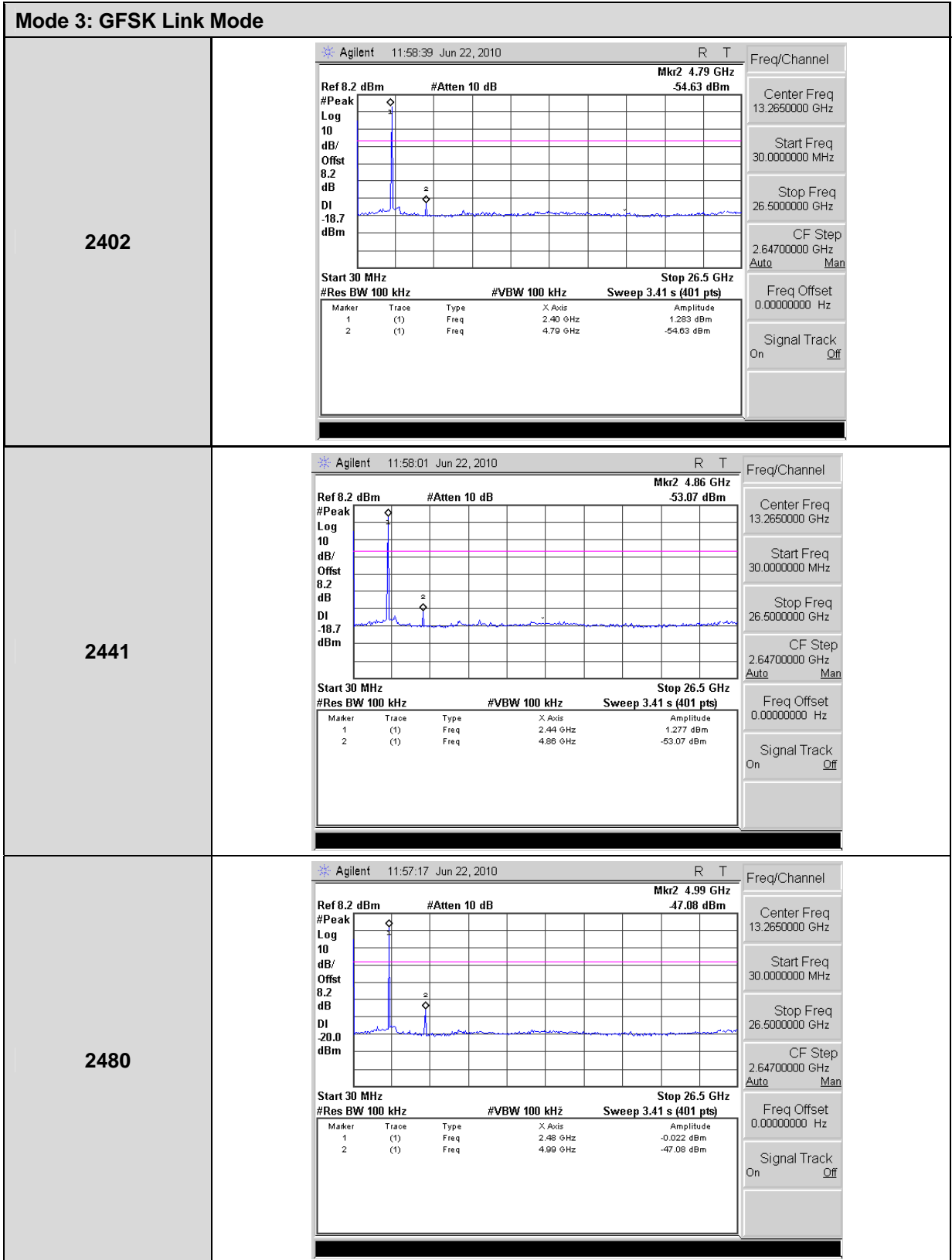

Mode 5: 8DPSK Link Mode	
2402	<p>Agilent 11:55:10 Jun 22, 2010 R T</p> <p>Ref 8.2 dBm #Atten 10 dB Mkr1 2.40 GHz -1.463 dBm</p> <p>#Peak Log 10 dB/Offst 8.2 dB DI -21.5 dBm</p> <p>V1 S2 S3 FC AA</p> <p>Start 30 MHz #Res BW 100 kHz #VBW 100 kHz Stop 26.5 GHz Sweep 3.41 s (401 pts)</p> <p>Freq/Channel: Center Freq 13.2650000 GHz, Start Freq 30.0000000 MHz, Stop Freq 26.5000000 GHz, CF Step 2.64700000 GHz, Freq Offset 0.00000000 Hz, Signal Track On</p>
2441	<p>Agilent 11:55:50 Jun 22, 2010 R T</p> <p>Ref 8.2 dBm #Atten 10 dB Mkr1 2.44 GHz -2.775 dBm</p> <p>#Peak Log 10 dB/Offst 8.2 dB DI -22.8 dBm</p> <p>V1 S2 S3 FC AA</p> <p>Start 30 MHz #Res BW 100 kHz #VBW 100 kHz Stop 26.5 GHz Sweep 3.41 s (401 pts)</p> <p>Freq/Channel: Center Freq 13.2650000 GHz, Start Freq 30.0000000 MHz, Stop Freq 26.5000000 GHz, CF Step 2.64700000 GHz, Freq Offset 0.00000000 Hz, Signal Track On</p>
2480	<p>Agilent 11:56:25 Jun 22, 2010 R T</p> <p>Ref 8.2 dBm #Atten 10 dB Mkr1 2.48 GHz -3.402 dBm</p> <p>#Peak Log 10 dB/Offst 8.2 dB DI -23.4 dBm</p> <p>V1 S2 S3 FC AA</p> <p>Start 30 MHz #Res BW 100 kHz #VBW 100 kHz Stop 26.5 GHz Sweep 3.41 s (401 pts)</p> <p>Freq/Channel: Center Freq 13.2650000 GHz, Start Freq 30.0000000 MHz, Stop Freq 26.5000000 GHz, CF Step 2.64700000 GHz, Freq Offset 0.00000000 Hz, Signal Track On</p>

12 Band Edges Measurement

12.1. Limit

In any 100 kHz bandwidth outside the frequency band in which the spread spectrum or digitally modulated intentional radiator is operating, the radio frequency power that is produced by the intentional radiator shall be at least 20 dB below that in the 100 kHz bandwidth within the band that contains the highest level of the desired power

12.2. Test Setup

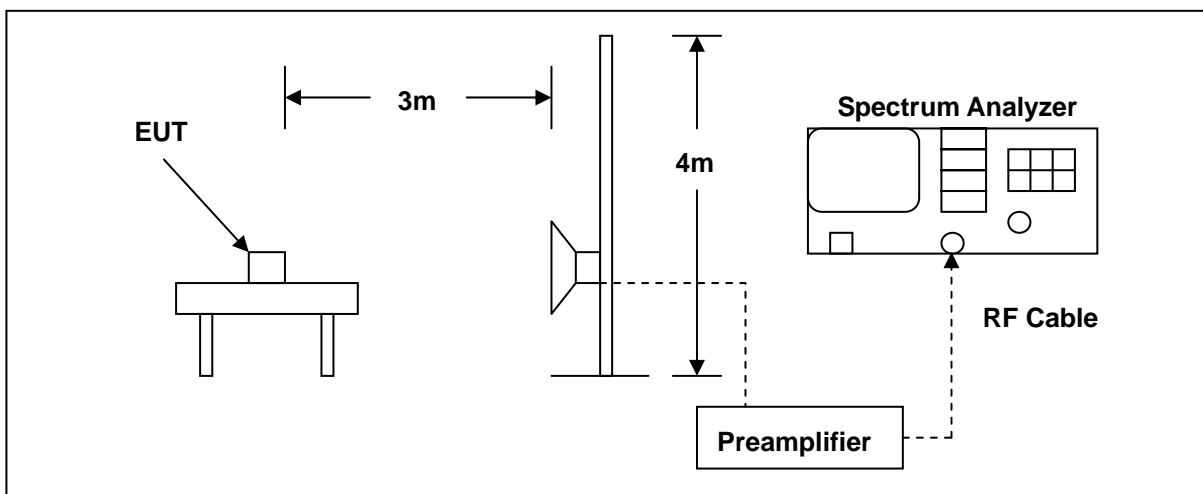

12.3. Test Instruments

Equipment	Manufacturer	Model Number	Serial Number	Cal. Date	Remark
Spectrum Analyzer	Agilent	E4408B	MY45107753	06/23/2009	(2)
Pre Amplifier	Agilent	8449B	3008A02237	07/01/2009	(1)
Horn Antenna	SCHWARZBECK MESS-ELEKTRONIK	9120D	9120D-550	07/01/2009	(2)
Test Site	ATL	TE06	TE06	N.C.R.	-----

Remark: ⁽¹⁾ Calibration period 1 year. ⁽²⁾ Calibration period 2 years.

NOTE: N.C.R. = No Calibration Request.

12.4. Test Procedure

The emissions on the harmonics frequencies, the limits, and the margin of compliance are presented. These tests were made when the transmitter was in full radiated power. The additional test was performed to show compliance with the requirement at the band-edge frequency 2483.5 MHz and up to 2500 MHz and at 2390.0 MHz.

The transmitter was configured with the worst case antenna and setup to transmit at the highest channel. Then the field strength was measured at 2483.5 MHz.

The transmitter was then configured with the worst case antenna and setup to transmit at the lowest channel. Then the field strength was measured at 2390.0 MHz. These tests were performed at 4 different bit rates.

12.5. Test Result

Standard:	FCC Part 15C	Test Distance:	3m
Test item:	Radiated Emission	Power:	AC 120V/60Hz
Model:	OT-200	Temp.(°C)/Hum.(%RH):	26(°C)/60%RH
Mode:	Mode 3	Date:	2010/06/20
Frequency:	2402 MHz	Test By:	Gary Wu
Ant.Polar.:	Horizontal		

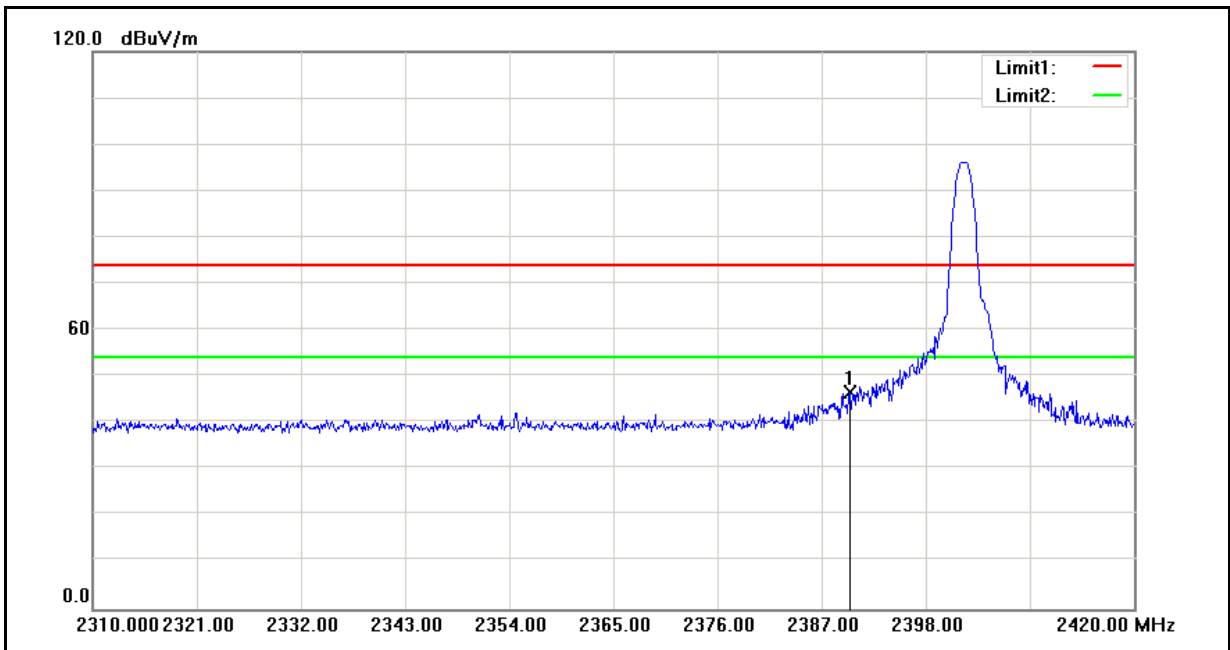

No.	Frequency (MHz)	Reading (dBuV)	Correct Factor(dB/m)	Result (dBuV/m)	Limit (dBuV/m)	Margin (dB)	Remark
1	2390.000	46.94	-0.24	46.70	74.00	-27.30	peak

Standard:	FCC Part 15C	Test Distance:	3m
Test item:	Radiated Emission	Power:	AC 120V/60Hz
Model:	OT-200	Temp.(°C)/Hum.(%RH):	26(°C)/60%RH
Mode:	Mode 3	Date:	2010/06/20
Frequency:	2402 MHz	Test By:	Gary Wu
Ant.Polar.:	Vertical		

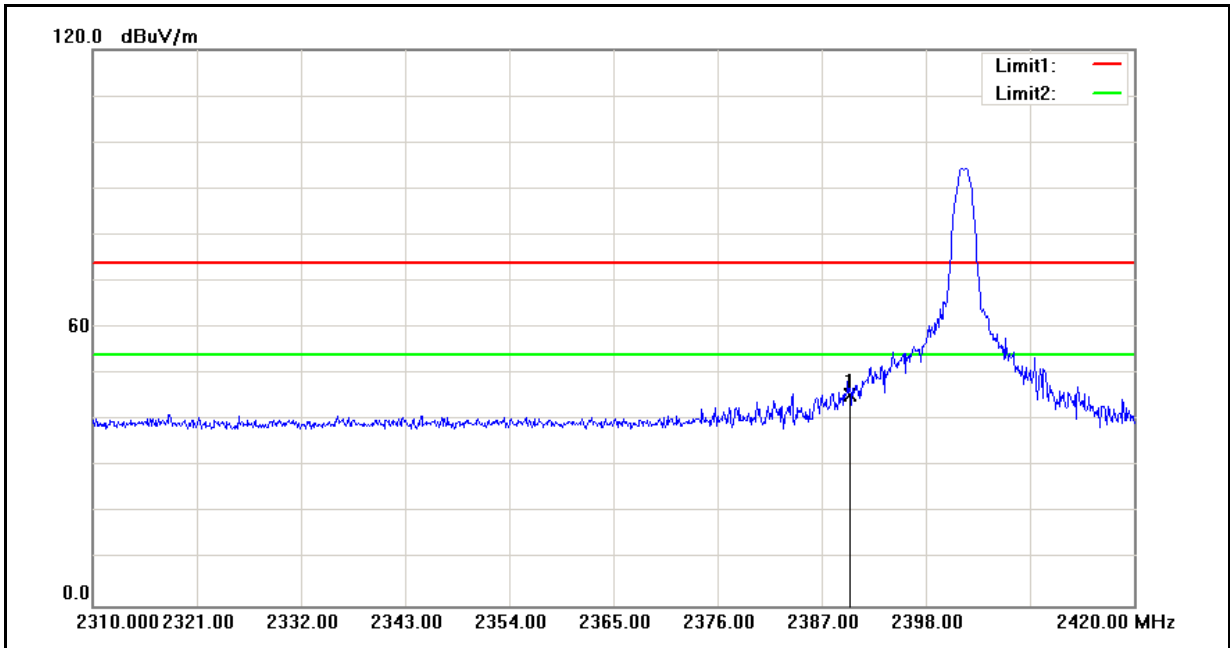

No.	Frequency (MHz)	Reading (dBuV)	Correct Factor(dB/m)	Result (dBuV/m)	Limit (dBuV/m)	Margin (dB)	Remark
1	2390.000	45.76	-0.24	45.52	74.00	-28.48	peak

Standard:	FCC Part 15C	Test Distance:	3m
Test item:	Radiated Emission	Power:	AC 120V/60Hz
Model:	OT-200	Temp.(°C)/Hum.(%RH):	26(°C)/60%RH
Mode:	Mode 3	Date:	2010/06/20
Frequency:	2480 MHz	Test By:	Gary Wu
Ant.Polar.:	Horizontal		

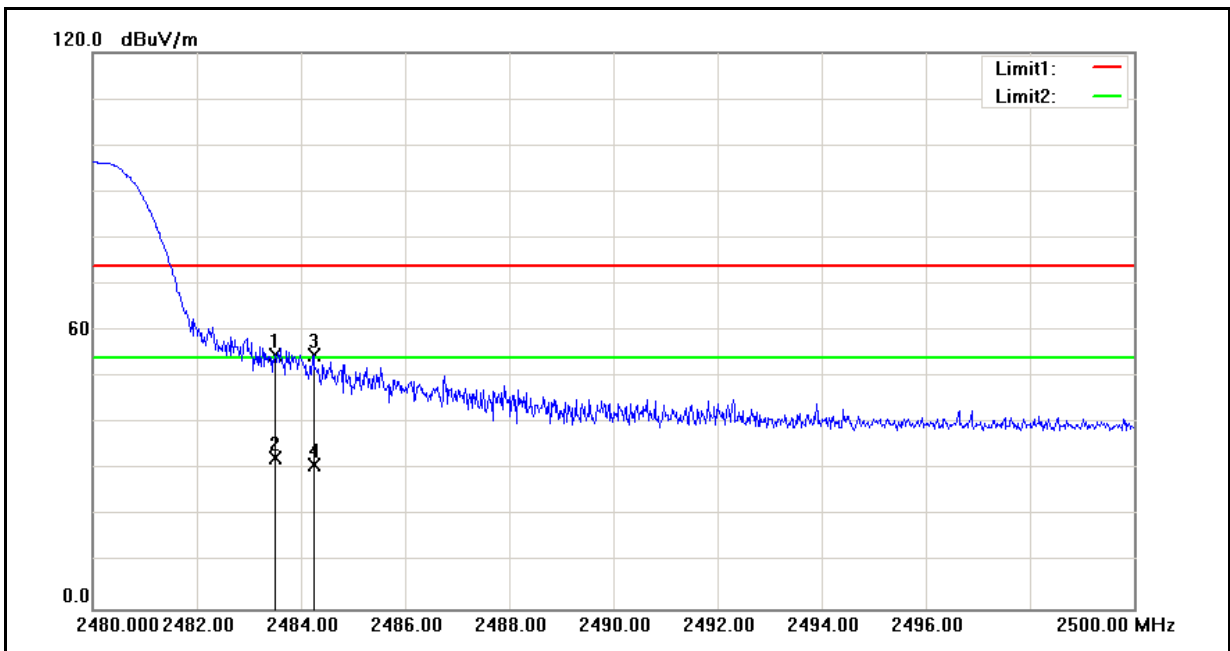

No.	Frequency (MHz)	Reading (dBuV)	Correct Factor(dB/m)	Result (dBuV/m)	Limit (dBuV/m)	Margin (dB)	Remark
1	2483.500	54.50	0.15	54.65	74.00	-19.35	peak
2	2483.500	32.26	0.15	32.41	54.00	-21.59	AVG
3	2484.240	54.58	0.16	54.74	74.00	-19.26	peak
4	2484.240	30.84	0.16	31.00	54.00	-23.00	AVG

Standard:	FCC Part 15C	Test Distance:	3m
Test item:	Radiated Emission	Power:	AC 120V/60Hz
Model:	OT-200	Temp.(°C)/Hum.(%RH):	26(°C)/60%RH
Mode:	Mode 3	Date:	2010/06/20
Frequency:	2480 MHz	Test By:	Gary Wu
Ant.Polar.:	Vertical		

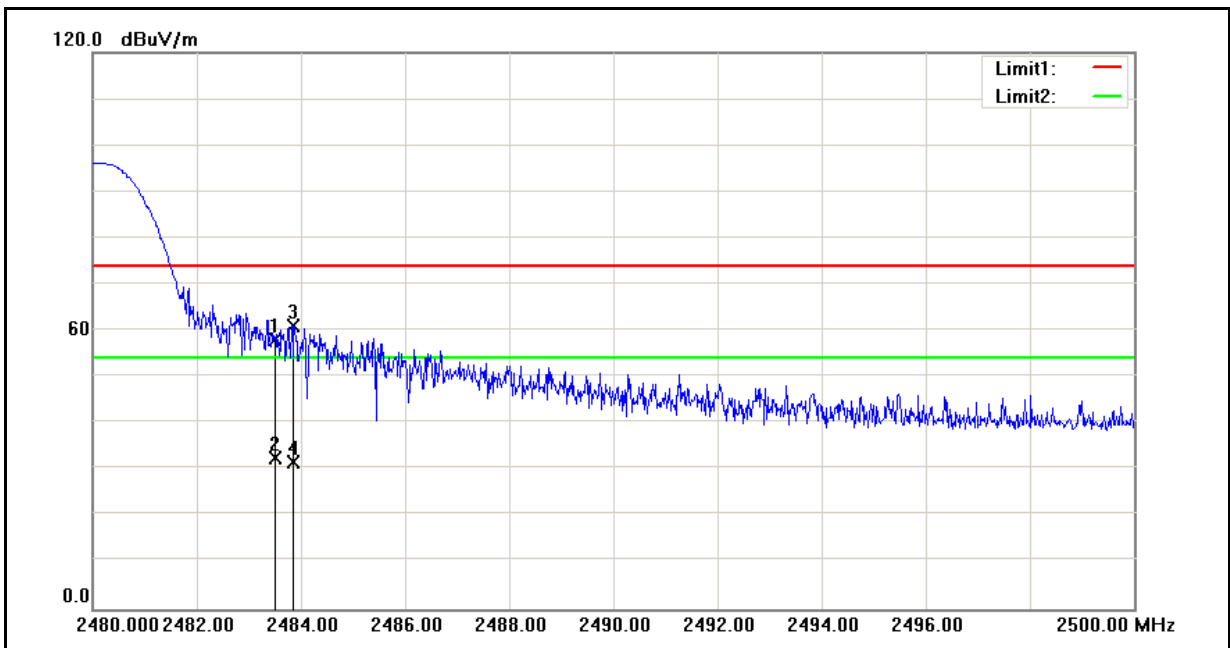

No.	Frequency (MHz)	Reading (dBuV)	Correct Factor(dB/m)	Result (dBuV/m)	Limit (dBuV/m)	Margin (dB)	Remark
1	2483.500	58.01	0.15	58.16	74.00	-15.84	peak
2	2483.500	32.28	0.15	32.43	54.00	-21.57	AVG
3	2483.860	61.00	0.15	61.15	74.00	-12.85	peak
4	2483.860	31.41	0.15	31.56	54.00	-22.44	AVG

Standard:	FCC Part 15C	Test Distance:	3m
Test item:	Radiated Emission	Power:	AC 120V/60Hz
Model:	OT-200	Temp.(°C)/Hum.(%RH):	26(°C)/60%RH
Mode:	Mode 5	Date:	2010/06/20
Frequency:	2402 MHz	Test By:	Gary Wu
Ant.Polar.:	Horizontal		

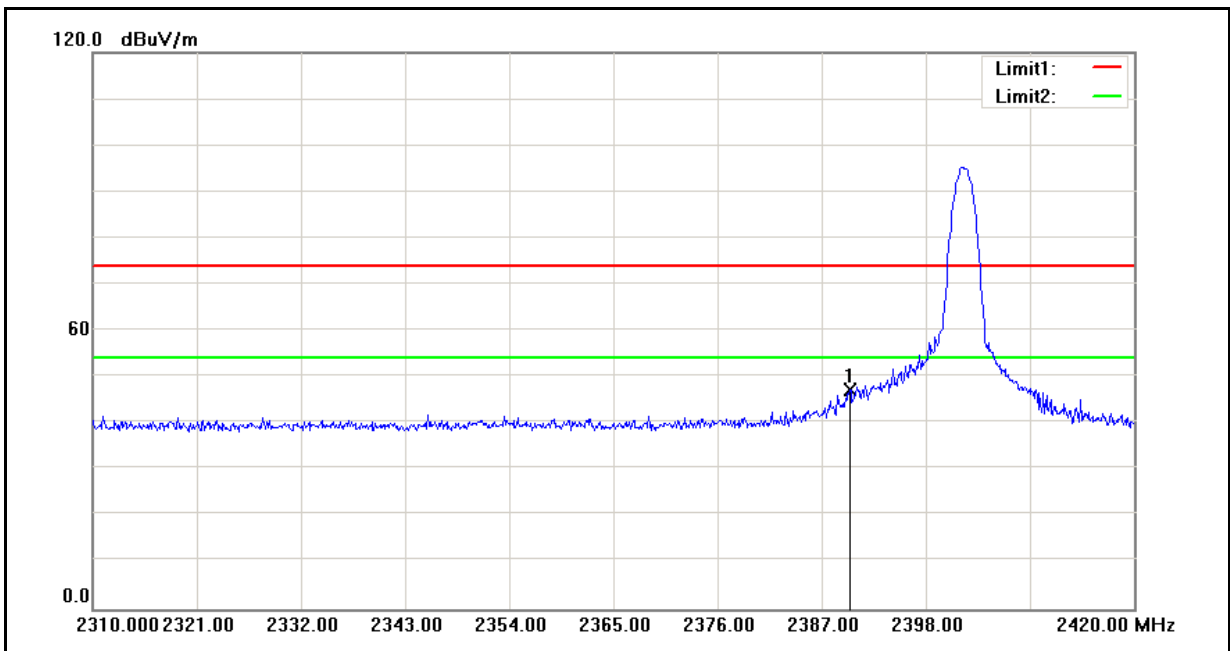

No.	Frequency (MHz)	Reading (dBuV)	Correct Factor(dB/m)	Result (dBuV/m)	Limit (dBuV/m)	Margin (dB)	Remark
1	2390.000	47.37	-0.24	47.13	74.00	-26.87	peak

Standard:	FCC Part 15C	Test Distance:	3m
Test item:	Radiated Emission	Power:	AC 120V/60Hz
Model:	OT-200	Temp.(°C)/Hum.(%RH):	26(°C)/60%RH
Mode:	Mode 5	Date:	2010/06/20
Frequency:	2402 MHz	Test By:	Gary Wu
Ant.Polar.:	Vertical		

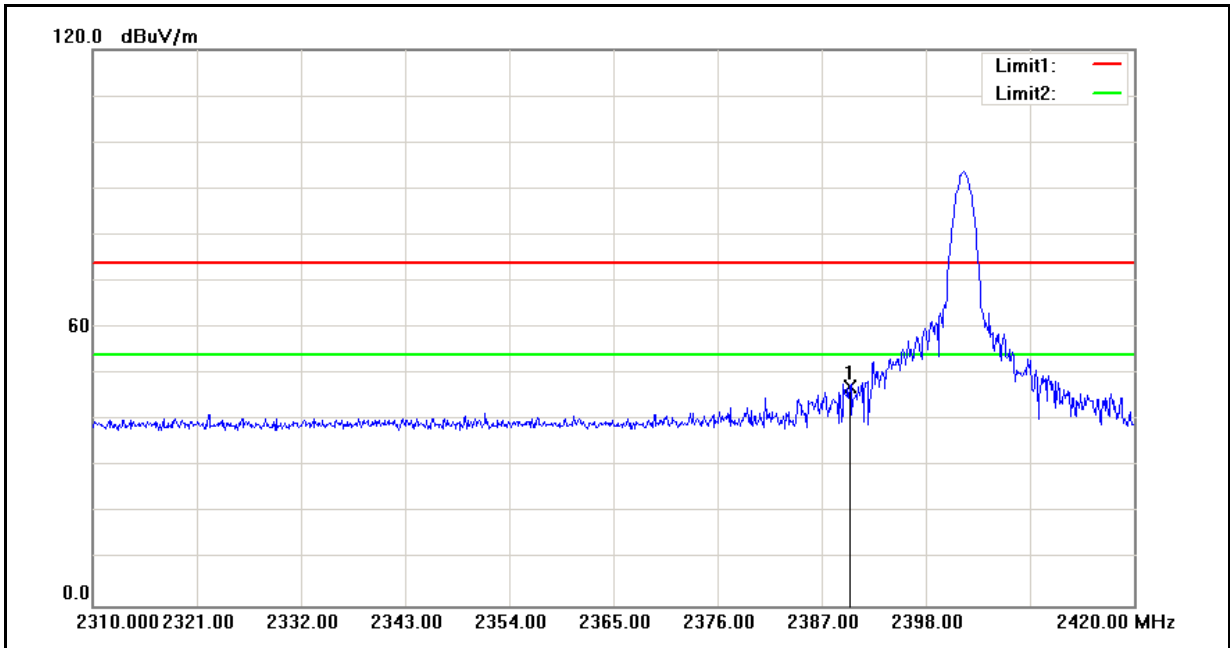

No.	Frequency (MHz)	Reading (dBuV)	Correct Factor(dB/m)	Result (dBuV/m)	Limit (dBuV/m)	Margin (dB)	Remark
1	2390.000	47.36	-0.24	47.12	74.00	-26.88	peak

Standard:	FCC Part 15C	Test Distance:	3m
Test item:	Radiated Emission	Power:	AC 120V/60Hz
Model:	OT-200	Temp.(°C)/Hum.(%RH):	26(°C)/60%RH
Mode:	Mode 5	Date:	2010/06/20
Frequency:	2480 MHz	Test By:	Gary Wu
Ant.Polar.:	Horizontal		

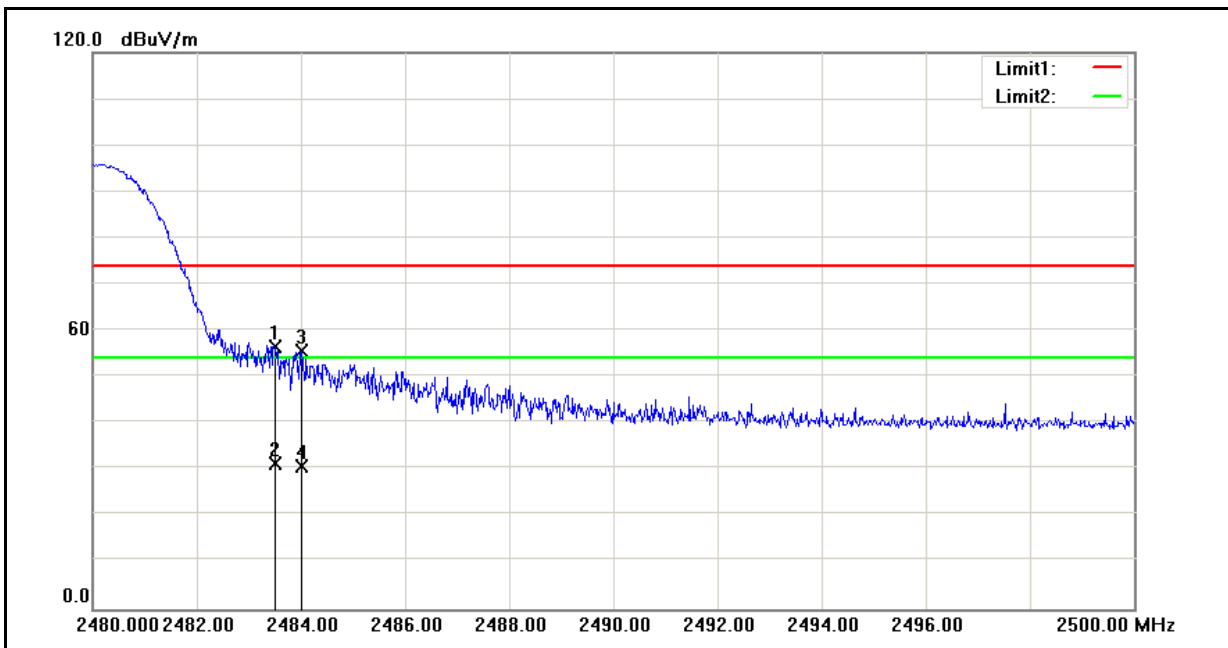

No.	Frequency (MHz)	Reading (dBuV)	Correct Factor(dB/m)	Result (dBuV/m)	Limit (dBuV/m)	Margin (dB)	Remark
1	2483.500	56.27	0.15	56.42	74.00	-17.58	peak
2	2483.500	31.25	0.15	31.40	54.00	-22.60	AVG
3	2484.000	55.48	0.16	55.64	74.00	-18.36	peak
4	2484.000	30.44	0.16	30.60	54.00	-23.40	AVG

Standard:	FCC Part 15C	Test Distance:	3m
Test item:	Radiated Emission	Power:	AC 120V/60Hz
Model:	OT-200	Temp.(°C)/Hum.(%RH):	26(°C)/60%RH
Mode:	Mode 5	Date:	2010/06/20
Frequency:	2480 MHz	Test By:	Gary Wu
Ant.Polar.:	Vertical		

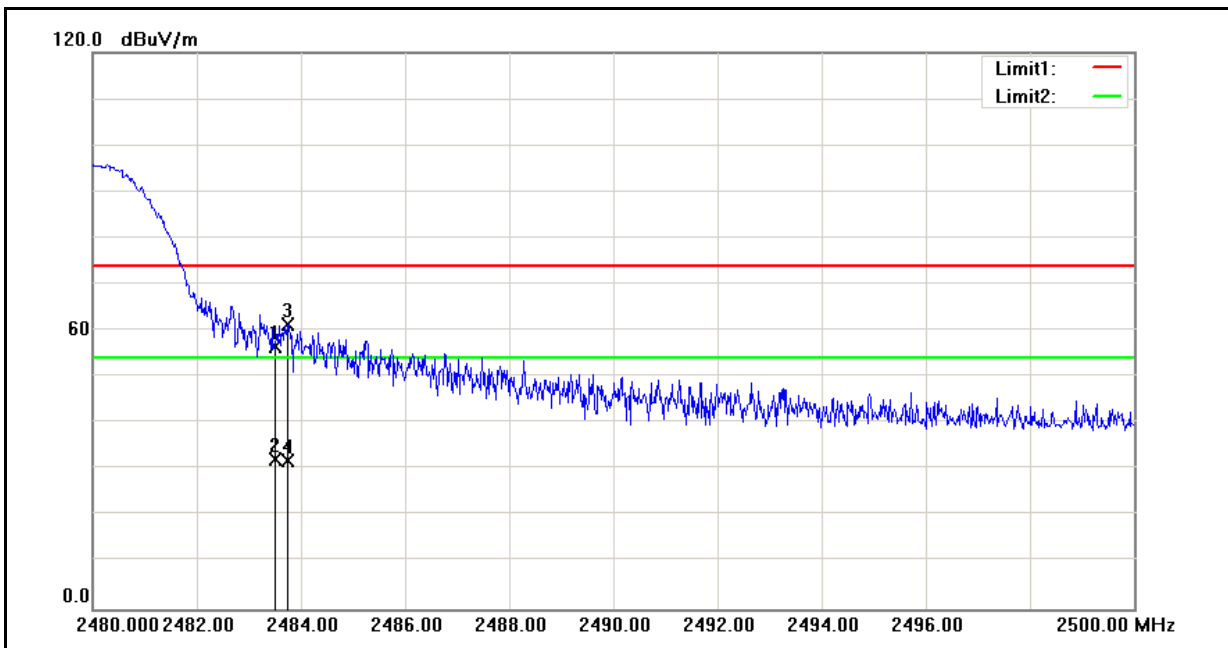

No.	Frequency (MHz)	Reading (dBuV)	Correct Factor(dB/m)	Result (dBuV/m)	Limit (dBuV/m)	Margin (dB)	Remark
1	2483.500	56.32	0.15	56.47	74.00	-17.53	peak
2	2483.500	32.05	0.15	32.20	54.00	-21.80	AVG
3	2483.740	61.27	0.15	61.42	74.00	-12.58	peak
4	2483.740	31.91	0.15	32.06	54.00	-21.94	AVG

13 99 % Occupied Bandwidth Measurement

13.1. Limit

N/A

13.2. Test Setup

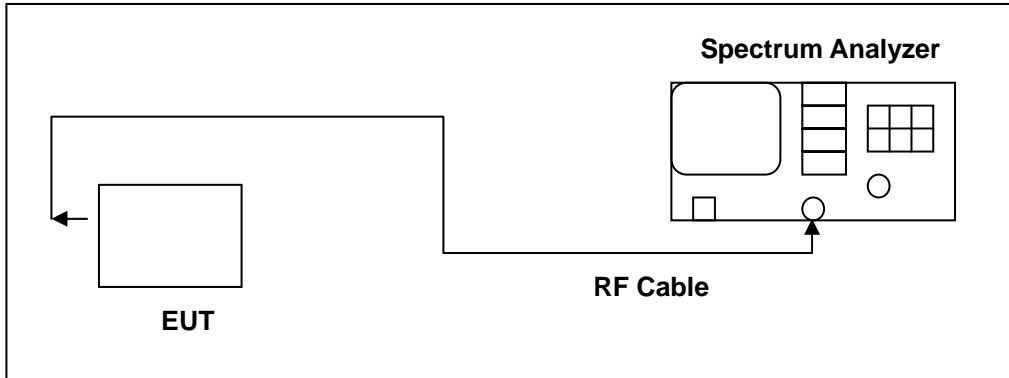

13.3. Test Instruments

Equipment	Manufacturer	Model Number	Serial Number	Cal. Date	Remark
Spectrum Analyzer	Agilent	E4445A	MY46181986	05/14/2009	⁽²⁾
Test Site	ATL	TE06	TE06	N.C.R.	-----

Remark: ⁽¹⁾ Calibration period 1 year. ⁽²⁾ Calibration period 2 years.

NOTE: N.C.R. = No Calibration Request.

13.4. Test Procedure

The transmitter output is connected to the spectrum analyzer. The RBW is set to 1% to 3% of the 99 % bandwidth. The VBW is set to 3 times the RBW. The sweep time is coupled.

13.5. Test Result

Model	OT-200		
Test Item	99 % Occupied Bandwidth		
Test Mode	Mode 3: GFSK Link Mode		
Date of Test	06/22/2010	Test Site	TE06
Frequency (MHz)	Measurement (MHz)		Limit (MHz)
2402	0.8622637		-----
2441	0.8611074		-----
2480	0.8620108		-----

Model	OT-200		
Test Item	99 % Occupied Bandwidth		
Test Mode	Mode 5: 8DPSK Link Mode		
Date of Test	06/22/2010	Test Site	TE06
Frequency (MHz)	Measurement (MHz)		Limit (MHz)
2402	1.2024		-----
2441	1.2044		-----
2480	1.2063		-----

13.6. Test Graphs

Mode 3: GFSK Link Mode	
2402	<p>Agilent 10:20:57 Jun 22, 2010 R T</p> <p>Ch Freq 2.402 GHz Trig Free</p> <p>Occupied Bandwidth</p> <p>Ref -10 dBm #Atten 0 dB</p> <p>#Peak Log 10 dB/</p> <p>Center 2.402 GHz Span 3 MHz #Res BW 10 kHz #VBW 30 kHz Sweep 31.08 ms (401 pts)</p> <p>Occupied Bandwidth 862.2637 kHz Occ BW % Pwr 99.00 % x dB -26.00 dB</p> <p>Transmit Freq Error 28.949 kHz x dB Bandwidth 1.187 MHz</p> <p>Freq/Channel</p> <p>Center Freq 2.4020000 GHz</p> <p>Start Freq 2.4005000 GHz</p> <p>Stop Freq 2.4035000 GHz</p> <p>CF Step 300.000000 kHz Auto Man</p> <p>Freq Offset 0.0000000 Hz</p> <p>Signal Track On Off</p>
2441	<p>Agilent 10:21:14 Jun 22, 2010 R T</p> <p>Ch Freq 2.441 GHz Trig Free</p> <p>Occupied Bandwidth</p> <p>Ref -10 dBm #Atten 0 dB</p> <p>#Peak Log 10 dB/</p> <p>Center 2.441 GHz Span 3 MHz #Res BW 10 kHz #VBW 30 kHz Sweep 31.08 ms (401 pts)</p> <p>Occupied Bandwidth 861.1074 kHz Occ BW % Pwr 99.00 % x dB -26.00 dB</p> <p>Transmit Freq Error 27.456 kHz x dB Bandwidth 1.185 MHz</p> <p>Freq/Channel</p> <p>Center Freq 2.4410000 GHz</p> <p>Start Freq 2.4395000 GHz</p> <p>Stop Freq 2.4425000 GHz</p> <p>CF Step 300.000000 kHz Auto Man</p> <p>Freq Offset 0.0000000 Hz</p> <p>Signal Track On Off</p>
2480	<p>Agilent 10:21:51 Jun 22, 2010 R T</p> <p>Ch Freq 2.48 GHz Trig Free</p> <p>Occupied Bandwidth</p> <p>Ref -10 dBm #Atten 0 dB</p> <p>#Peak Log 10 dB/</p> <p>Center 2.48 GHz Span 3 MHz #Res BW 10 kHz #VBW 30 kHz Sweep 31.08 ms (401 pts)</p> <p>Occupied Bandwidth 862.0108 kHz Occ BW % Pwr 99.00 % x dB -26.00 dB</p> <p>Transmit Freq Error 27.393 kHz x dB Bandwidth 1.182 MHz</p> <p>Freq/Channel</p> <p>Center Freq 2.4800000 GHz</p> <p>Start Freq 2.4785000 GHz</p> <p>Stop Freq 2.4815000 GHz</p> <p>CF Step 300.000000 kHz Auto Man</p> <p>Freq Offset 0.0000000 Hz</p> <p>Signal Track On Off</p>

Mode 5: 8DPSK Link Mode	
2402	<p>Agilent 10:22:45 Jun 22, 2010 R T</p> <p>Ch Freq 2.402 GHz Trig Free</p> <p>Occupied Bandwidth</p> <p>Ref -10 dBm #Atten 0 dB</p> <p>#Peak Log 10 dB/</p> <p>Center 2.402 GHz Span 3 MHz #Res BW 10 kHz #VBW 30 kHz Sweep 31.08 ms (401 pts)</p> <p>Occupied Bandwidth 1.2024 MHz Occ BW % Pwr 99.00 % x dB -26.00 dB</p> <p>Transmit Freq Error 22.169 kHz x dB Bandwidth 1.390 MHz</p> <p>Freq/Channel: Center Freq 2.40200000 GHz, Start Freq 2.40050000 GHz, Stop Freq 2.40350000 GHz, CF Step 300.000000 kHz, Freq Offset 0.00000000 Hz, Signal Track On</p>
2441	<p>Agilent 10:22:26 Jun 22, 2010 R T</p> <p>Ch Freq 2.441 GHz Trig Free</p> <p>Occupied Bandwidth</p> <p>Ref -10 dBm #Atten 0 dB</p> <p>#Peak Log 10 dB/</p> <p>Center 2.441 GHz Span 3 MHz #Res BW 10 kHz #VBW 30 kHz Sweep 31.08 ms (401 pts)</p> <p>Occupied Bandwidth 1.2044 MHz Occ BW % Pwr 99.00 % x dB -26.00 dB</p> <p>Transmit Freq Error 22.597 kHz x dB Bandwidth 1.391 MHz</p> <p>Freq/Channel: Center Freq 2.44100000 GHz, Start Freq 2.43950000 GHz, Stop Freq 2.44250000 GHz, CF Step 300.000000 kHz, Freq Offset 0.00000000 Hz, Signal Track On</p>
2480	<p>Agilent 10:22:08 Jun 22, 2010 R T</p> <p>Ch Freq 2.48 GHz Trig Free</p> <p>Occupied Bandwidth</p> <p>Ref -10 dBm #Atten 0 dB</p> <p>#Peak Log 10 dB/</p> <p>Center 2.48 GHz Span 3 MHz #Res BW 10 kHz #VBW 30 kHz Sweep 31.08 ms (401 pts)</p> <p>Occupied Bandwidth 1.2063 MHz Occ BW % Pwr 99.00 % x dB -26.00 dB</p> <p>Transmit Freq Error 21.662 kHz x dB Bandwidth 1.387 MHz</p> <p>Freq/Channel: Center Freq 2.48000000 GHz, Start Freq 2.47850000 GHz, Stop Freq 2.48150000 GHz, CF Step 300.000000 kHz, Freq Offset 0.00000000 Hz, Signal Track On</p>

14 Antenna Measurement

14.1. Limit

For intentional device, according to 15.203, an intentional radiator shall be designed to ensure that no antenna other than that furnished by the responsible party shall be used with the device.

And According to 15.247 (b), if transmitting antennas of directional gain greater than 6 dBi are used, the power shall be reduced by the amount in dB that the directional gain of the antenna exceeds 6dBi.

14.2. Antenna Connector Construction

The antenna used in this product is **Internal antenna**. And the maximum Gain of this antenna is only **2.94 dBi**.