



FCC TEST REPORT (Bluetooth)

according to

FCC Rules and Regulations Part 15 Subpart C

Applicant	: Partner Tech Corp.
Address	: 10FL, 233-2, Baoqiao Road, Xindian, New Taipei City, Taiwan
Equipment	: Handheld Terminal
Model No.	: OT-110
FCC ID	: NDPOT-110
Trade Name	: Partner

- The test result refers exclusively to the test presented test model / sample.,
- Without written approval of **CerpPASS Technology Corp.** the test report shall not be reproduced except in full.
- The EUT is also considered as a kind of computer peripheral, because the connection to computer is necessary for typical use. It has been verified to comply with the requirements of FCC Part 15, Subpart B, Class B (DoC). The test report has been issued separately.



Contents

1. Report of Measurements and Examinations	5
1.1 List of Measurements and Examinations.....	5
2. Test Configuration of Equipment under Test	6
2.1 Feature of Equipment under Test.....	6
2.2 Test Mode & Test Software	7
2.3 Description of Test System.....	7
2.4 General Information of Test.....	8
2.5 Measurement Uncertainty	8
2.6 History of this test report	9
3. Antenna Requirements	10
3.1 Standard Applicable	10
3.2 Antenna Construction and Directional Gain.....	10
4. Test of Conducted Emission	11
4.1 Test Limit.....	11
4.2 Test Procedures.....	11
4.3 Typical Test Setup	12
4.4 Measurement equipment	12
4.5 Test Result and Data.....	13
4.6 Test Photographs	31
5. Test of Radiated Emission	32
5.1 Test Limit.....	32
5.2 Test Procedures.....	32
5.3 Typical Test Setup	33
5.4 Measurement equipment	33
5.5 Test Result and Data.....	34
5.6 Test Photographs	94
6. 20dB Bandwidth Measurement Data	96
6.1 Test Limit	96
6.2 Test Procedures	96
6.3 Test Setup Layout	96
6.4 Measurement equipment	96
6.5 Test Result and Data.....	97
7. Frequencies Separation	103
7.1 Test Limit	103
7.2 Test Procedures	103
7.3 Test Setup Layout	103
7.4 Measurement equipment	103
7.5 Test Result and Data.....	104
8. Dwell Time on each channel	110
8.1 Test Limit	110
8.2 Test Procedures	110
8.3 Test Setup Layout	110
8.4 Measurement equipment	110
8.5 Test Result and Data.....	111



9. Number of Hopping Channels 121

9.1 Test Limit 121

9.2 Test Procedures 121

9.3 Test Setup Layout 121

9.4 Measurement equipment 121

9.5 Test Result and Data 121

10. Maximum Peak Output Power 124

10.1 Test Limit 124

10.2 Test Procedures 124

10.3 Test Setup Layout 124

10.4 Measurement equipment 124

10.5 Test Result and Data 125

11. Band Edges Measurement 131

11.1 Test Limit 131

11.2 Test Procedure : 131

11.3 Test Setup Layout 131

11.4 List of Measuring Equipment Used 131

11.5 Test Result and Data 132

11.6 Restrict band emission Measurement Data 139

12. Restricted Bands of Operation 142

12.1 Labeling Requirement 142

Appendix A. Photographs of EUT.....A1 ~ A24



CERTIFICATE OF COMPLIANCE

according to

FCC Rules and Regulations Part 15 Subpart C

Applicant : Partner Tech Corp.
Address : 10FL, 233-2, Baoqiao Road, Xindian,
New Taipei City, Taiwan
Equipment : Handheld Terminal
Model No. : OT-110
FCC ID : NDPOT-110

I **HEREBY** CERTIFY THAT :

The measurements shown in this test report were made in accordance with the procedures given in **ANSI C63.4** The equipment was **passed** the test performed according to **FCC Rules and Regulations Part 15 Subpart C (2010)**.

The test was carried out on Jul. 09, 2011 at **Cerpass Technology Corp.**

Signature

Clark Lin
EMC/RF B.U. Deputy Manager



1. Report of Measurements and Examinations

1.1 List of Measurements and Examinations

FCC Rule	Description of Test	Result
15.203	. Antenna Requirement	Pass
15.207	. Conducted Emission	Pass
15.209	. Radiated Emission	Pass
15.247(a)(1)	. Channel Carrier Frequencies Separation	Pass
15.247(a)(1)	. 20dB Bandwidth Measurement	Pass
15.247(a)(1)	. Dwell Time	Pass
15.247(b)	. Number of Hopping Channels	Pass
15.247(b)	. Peak Output Power Measurement Data	Pass
15.247(d)	. Band Edges Measurement Data	Pass



2. Test Configuration of Equipment under Test

2.1 Feature of Equipment under Test

CPU	CPU Samsung S3C 6410 667MHz
Memory	Mobile DDR 128MB, NAND flash 256MB
LCD	4.3" widescreen (resolution 272*480)
WiFi	802.11 b/g
Frequency	2412-2462MHz
Bluetooth	Class 2
Connection Interface	WLAN 802.11 b/g, Mini USB 2.0 (Client) / 1.1 (Host)
Numbers of channel	WLAN: 11channels; Bluetooth: 79channels
Modulation	DSSS, OFDM, FHSS
Audio	Speaker, Internal microphone, earphone jack, microphone jack
Storage	Micro SD Card (support SDHC)
Special features	Vibrator motor (for alerts) 4-way direction sensor Ambient light sensor Backup restore utility
Battery	Li-ion 2200mAh (with Gas Gauge)
Ruggedness	IP54, 1.2 meter drop test
Operating System	Windows CE 6.0
Dimensions	133 * 82 * 19 mm(H x W x D)
Option	Sunlight-readable panel with power-saving function MSR Track 1, 2, 3 Barcode Scanner 1D/2D RFID 13.56MHz (Mifare)
Weight	Approx. 220g with battery
Adapter	Touch \ M8-10US05R CWT \ KPC-010B

Bluetooth:

Transmit Power	GFSK: -0.04dBm, $\pi/4$ -DQPSK: -4.33dBm, 8DPSK: -3.87dBm
----------------	---

RFID:

Type of Modulation	FSK
Number of Channels	1
Frequency Band	13.56MHz
Carrier Frequency of each channel	13.56MHz



2.2 Test Mode & Test Software

- a. During testing, the interface cables and equipment positions were varied according to ANSI C63.4
- b. The complete test system included EUT and Earphone for EMI test.
- c. The EUT was executed to keep transmitting and receiving data via Bluetooth.
- d. The following test mode was performed for conduction and radiation test:

Adapter: CWT \ KPC-010B

- GFSK: CH 00: 2402MHz, CH 39: 2441MHz, CH 78: 2480MHz.
- $\pi/4$ -DQPSK: CH 00: 2402MHz, CH 39: 2441MHz, CH 78: 2480MHz.
- 8DPSK: CH 00: 2402MHz, CH 39: 2441MHz, CH 78: 2480MHz.

Adapter: Touch \ M8-10US05R

- GFSK: CH 00: 2402MHz, CH 39: 2441MHz, CH 78: 2480MHz.
- $\pi/4$ -DQPSK: CH 00: 2402MHz, CH 39: 2441MHz, CH 78: 2480MHz.
- 8DPSK: CH 00: 2402MHz, CH 39: 2441MHz, CH 78: 2480MHz.

2.3 Description of Test System

Device	Manufacturer	Model No.	Description
Earphone	MIC	MIC-4	Audio Cable, Unshielding 1.35 m



2.4 General Information of Test

Test Site :	CerpPASS Technology Corp. 2F-11, No. 3, Yuan Qu St., (Nankang Software Park), Taipei, Taiwan 115, R.O.C.
Test Site Location (OATS2-SD) :	No.68-1, Shihbachongsi, Shihding Township, Taipei City 223, Taiwan, R.O.C.
FCC Registration Number :	TW1049, TW1061, 488071, 390316
IC Registration Number :	4934B-1, 4934D-1
VCCI Registration Number :	T-543 for Telecommunication Test C-3328 for Conducted emission test R-3013 for Radiated emission test G-97 for radiated disturbance above 1GHz
Test Voltage:	AC 120V/ 60Hz
Test in Compliance with:	ANSI C63.4-2009 FCC Part 15 Subpart C
Frequency Range Investigated:	Conducted: from 150kHz to 30 MHz Radiation: from 30 MHz to 248000MHz
Test Distance:	The test distance of radiated emission from antenna to EUT is 3 M.

2.5 Measurement Uncertainty

Measurement Item	Measurement Frequency	Polarization	Uncertainty
Conducted Emission	9 kHz ~ 30 MHz	LINE/NEUTRAL	2.71 dB
Radiated Emission	30 MHz ~ 1GHz	Vertical	4.11 dB
		Horizontal	4.10 dB
6 dB Bandwidth	---	---	7500 Hz
Maximum Peak Output Power	---	---	1.4 dB
100kHz Bandwidth of Frequency Band Edges	---	---	2.2 dB
Power Spectral Density	---	---	2.2 dB

**2.6 History of this test report** ORIGINAL. Additional attachment as following record:

Attachment No.	Issue Date	Description



3. Antenna Requirements

3.1 Standard Applicable

For intentional device, according to FCC 47 CFR Section 15.203, an intentional radiator shall be designed to ensure that no antenna other than that furnished by the responsible party shall be used with the device.

And according to FCC 47 CFR Section 15.247 (b), if transmitting antennas of directional gain greater than 6dBi are used, the power shall be reduced by the amount in dB that the directional gain of the antenna exceeds 6dBi.

3.2 Antenna Construction and Directional Gain

Antenna type: PIFA Antenna

Antenna Gain: 2.9231 dBi



4. Test of Conducted Emission

4.1 Test Limit

Conducted Emissions were measured from 150 kHz to 30 MHz with a bandwidth of 9 KHz on the 120 VAC power and return leads of the EUT according to the methods defined in ANSI C63.4-2003 Section 3.1. The EUT was placed on a nonmetallic stand in a shielded room 0.8 meters above the ground plane as shown in section 2.2. The interface cables and equipment positioning were varied within limits of reasonable applications to determine the position produced maximum conducted emissions.

Frequency (MHz)	Quasi Peak (dB μ V)	Average (dB μ V)
0.15 – 0.5	66-56*	56-46*
0.5 – 5.0	56	46
5.0 – 30.0	60	50

*Decreases with the logarithm of the frequency.

4.2 Test Procedures

- a. The EUT was placed 0.4 meter from the conducting wall of the shielding room was kept at least 80 centimeters from any other grounded conducting surface.
- b. Connect EUT to the power mains through a line impedance stabilization network (LISN).
- c. All the support units are connecting to the other LISN.
- d. The LISN provides 50 ohm coupling impedance for the measuring instrument.
- e. The FCC states that a 50 ohm, 50 micro-Henry LISN should be used.
- f. Both sides of AC line were checked for maximum conducted interference.
- g. The frequency range from 150 kHz to 30 MHz was searched.
- h. Set the test-receiver system to Peak Detect Function and Specified Bandwidth with Maximum Hold Mode.



4.3 Typical Test Setup

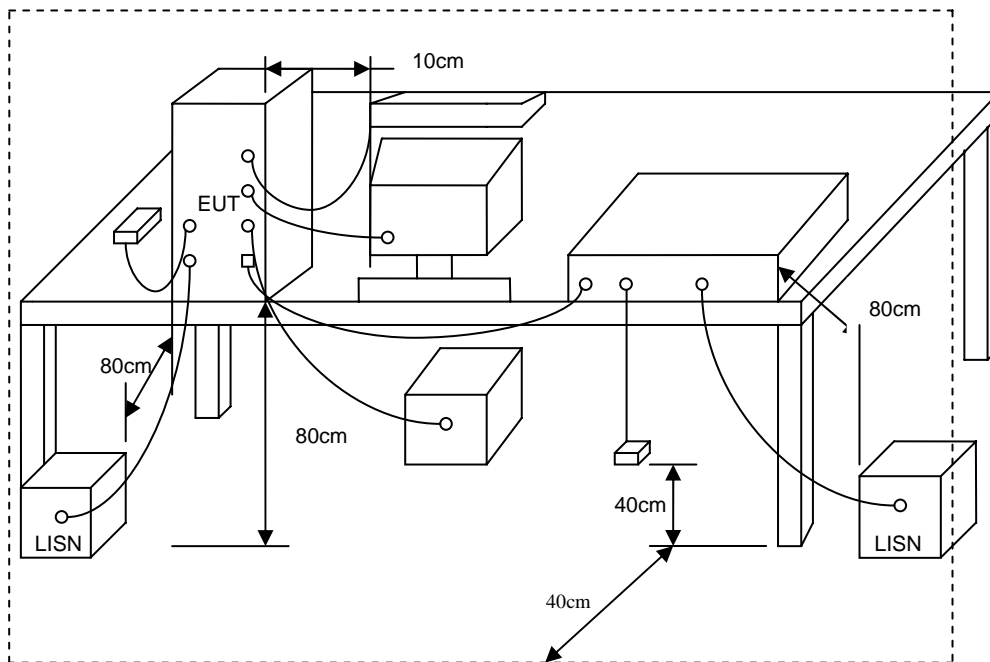

4.4 Measurement equipment

Instrument/Ancillary	Manufacturer	Model No.	Serial No.	Calibration Date	Valid Date.
EMI Receiver	R&S	ESCI	100443	2011/02/08	2012/02/07
LISN	Schwarzbeck	NSLK 8127	8127-516	2011/05/05	2012/05/04
LISN	MessTec	NNS-2/16L	02/10191	2010/07/19	2011/07/18



4.5 Test Result and Data

Power	: AC 120V	Pol/Phase	: LINE
Test Mode	: GFSK CH0	Temperature	: 25 °C
Memo	: Adapter: CWT \ KPC-010B	Humidity	: 50 %

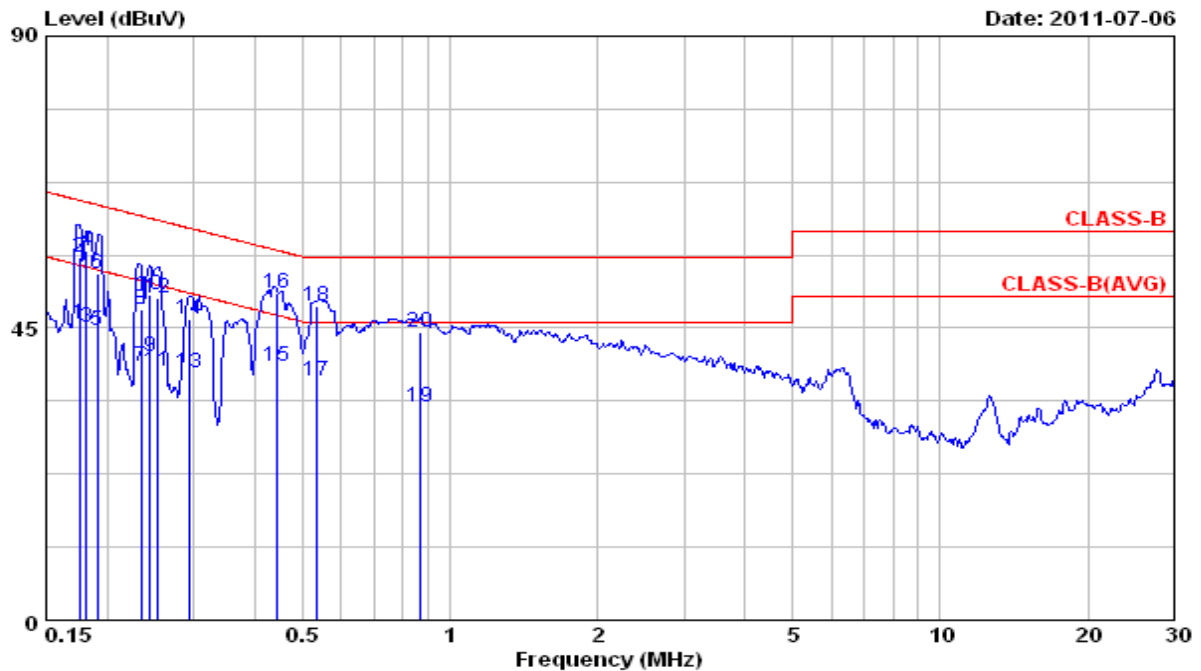

Item	Freq MHz	Read Value dBuV	Factor dB/m	Result dBuV/m	Limit dBuV/m	Margin dB	Remark
1	0.175	45.51	0.07	45.58	54.70	-9.12	Average
2	0.175	55.81	0.07	55.88	64.70	-8.82	QP
3	0.182	45.11	0.07	45.18	54.41	-9.23	Average
4	0.182	56.73	0.07	56.80	64.41	-7.61	QP
5	0.191	44.53	0.07	44.60	54.01	-9.41	Average
6	0.191	53.27	0.07	53.34	64.01	-10.67	QP
7	0.234	39.13	0.07	39.20	52.30	-13.10	Average
8	0.234	47.84	0.07	47.91	62.30	-14.39	QP
9	0.244	40.50	0.07	40.57	51.95	-11.38	Average
10	0.244	50.17	0.07	50.24	61.95	-11.71	QP
11	0.252	38.33	0.07	38.40	51.69	-13.29	Average
12	0.252	49.47	0.07	49.54	61.69	-12.15	QP
13	0.295	37.98	0.08	38.06	50.38	-12.32	Average
14	0.295	46.19	0.08	46.27	60.38	-14.11	QP
15	0.444	38.95	0.08	39.03	46.99	-7.96	Average
16	0.444	50.21	0.08	50.29	56.99	-6.70	QP
17	0.535	36.67	0.09	36.76	46.00	-9.24	Average
18	0.535	48.23	0.09	48.32	56.00	-7.68	QP

Notes:

1. Result = Read Value + Factor
2. Factor = LISN Factor + Cable Loss
3. According to technical experiences, all spurious emission of BT mode at channel 0,39,78 are almost the same below 1GHz, so that the channel 0 was chosen as representative in final test.
4. The data is worst case.



Power	: AC 120V	Pol/Phase	: LINE
Test Mode	: GFSK CH0	Temperature	: 25 °C
Memo	: Adapter: CWT \ KPC-010B	Humidity	: 50 %

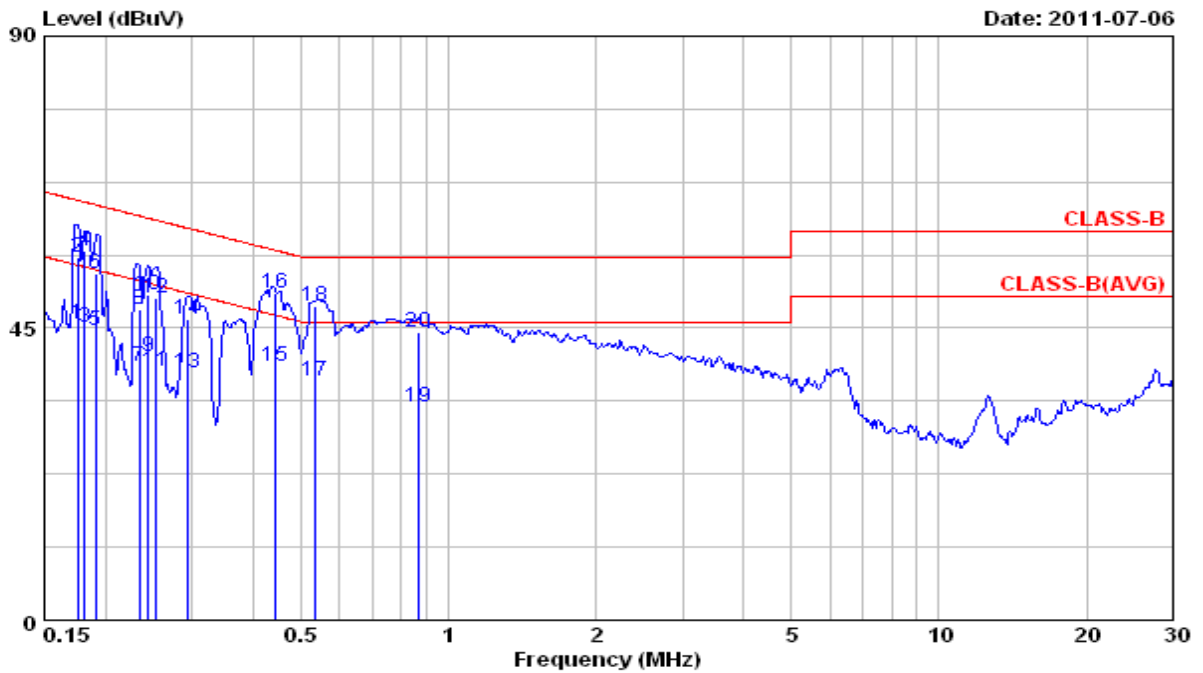

Item	Freq	Read Value	Factor	Result	Limit	Margin	Remark
	MHz	dBuV	dB/m	dBuV/m	dBuV/m	dB	
19	0.865	32.72	0.10	32.82	46.00	-13.18	Average
20	0.865	44.40	0.10	44.50	56.00	-11.50	QP

Notes:

1. Result = Read Value + Factor
2. Factor = LISN Factor + Cable Loss
3. According to technical experiences, all spurious emission of BT mode at channel 0,39,78 are almost the same below 1GHz, so that the channel 0 was chosen as representative in final test.
4. The data is worst case.



Power	: AC 120V	Pol/Phase	: NEUTRAL
Test Mode	: GFSK CH0	Temperature	: 25 °C
Memo	: Adapter: CWT \ KPC-010B	Humidity	: 50 %

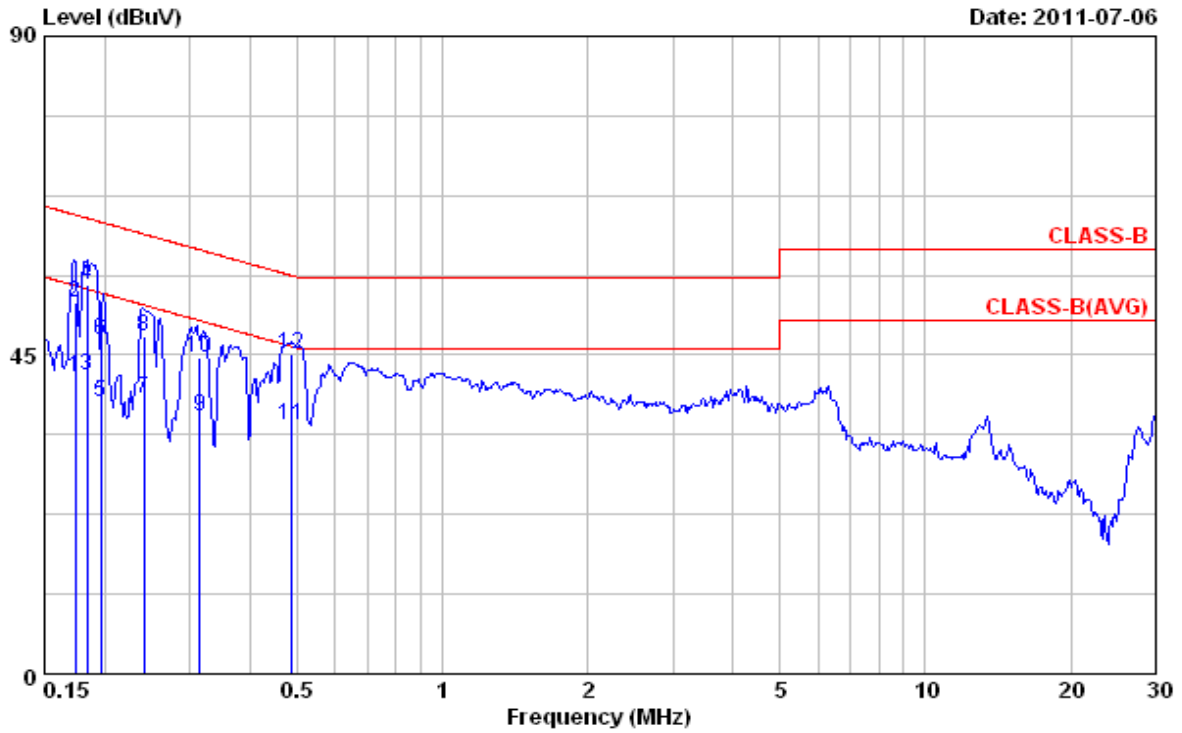

Item	Freq	Read Value	Factor	Result	Limit	Margin	Remark
	MHz	dBuV	dB/m	dBuV/m	dBuV/m	dB	
1	0.174	41.85	0.07	41.92	54.76	-12.84	Average
2	0.174	52.33	0.07	52.40	64.76	-12.36	QP
3	0.183	42.11	0.07	42.18	54.33	-12.15	Average
4	0.183	54.83	0.07	54.90	64.33	-9.43	QP
5	0.196	38.22	0.07	38.29	53.77	-15.48	Average
6	0.196	47.03	0.07	47.10	63.77	-16.67	QP
7	0.241	38.87	0.07	38.94	52.07	-13.13	Average
8	0.241	47.56	0.07	47.63	62.07	-14.44	QP
9	0.314	36.34	0.08	36.42	49.87	-13.45	Average
10	0.314	44.67	0.08	44.75	59.87	-15.12	QP
11	0.488	35.12	0.08	35.20	46.21	-11.01	Average
12	0.488	45.03	0.08	45.11	56.21	-11.10	QP

Notes:

1. Result = Read Value + Factor
2. Factor = LISN Factor + Cable Loss
3. According to technical experiences, all spurious emission of BT mode at channel 0,39,78 are almost the same below 1GHz, so that the channel 0 was chosen as representative in final test.
4. The data is worst case.



Power	: AC 120V	Pol/Phase	: LINE
Test Mode	: $\pi/4$ -DQPSK CH0	Temperature	: 25 °C
Memo	: Adapter: CWT \ KPC-010B	Humidity	: 50 %

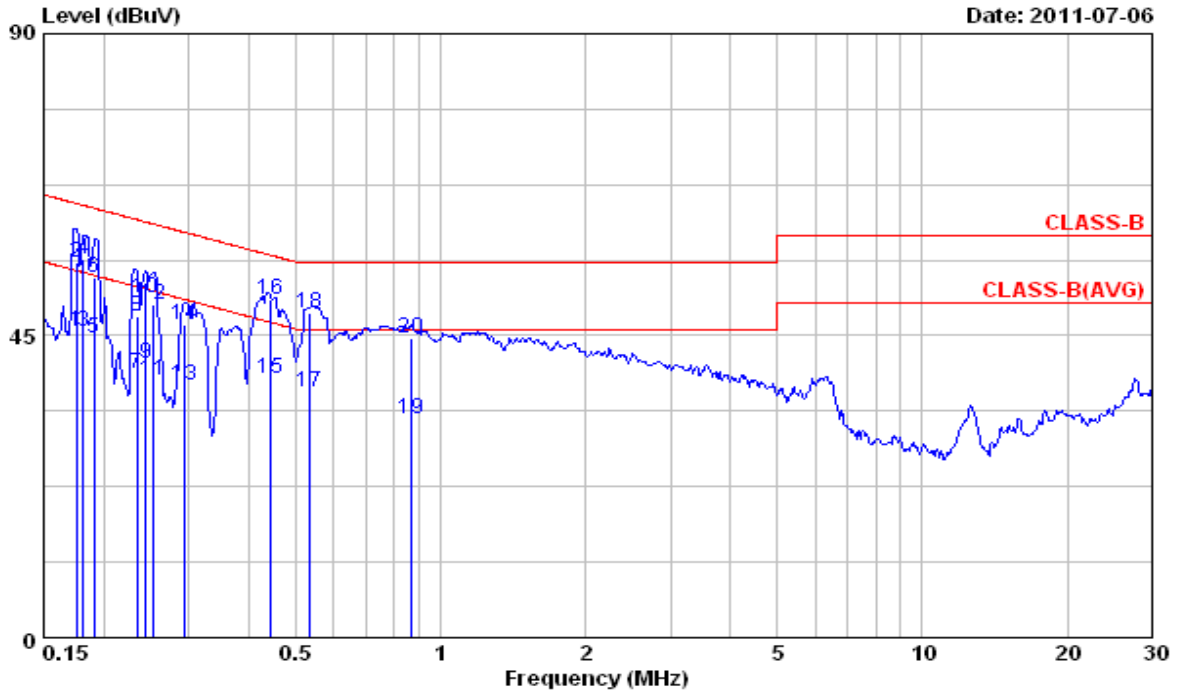

Item	Freq	Read Value	Factor	Result	Limit	Margin	Remark
	MHz	dBuV	dB/m	dBuV/m	dBuV/m	dB	
1	0.175	45.58	0.07	45.65	54.70	-9.05	Average
2	0.175	55.83	0.07	55.90	64.70	-8.80	QP
3	0.182	45.56	0.07	45.63	54.41	-8.78	Average
4	0.182	56.46	0.07	56.53	64.41	-7.88	QP
5	0.191	44.56	0.07	44.63	54.01	-9.38	Average
6	0.191	53.65	0.07	53.72	64.01	-10.29	QP
7	0.234	39.23	0.07	39.30	52.30	-13.00	Average
8	0.234	47.86	0.07	47.93	62.30	-14.37	QP
9	0.244	40.68	0.07	40.75	51.95	-11.20	Average
10	0.244	50.57	0.07	50.64	61.95	-11.31	QP
11	0.252	38.40	0.07	38.47	51.69	-13.22	Average
12	0.252	49.67	0.07	49.74	61.69	-11.95	QP
13	0.295	37.56	0.08	37.64	50.38	-12.74	Average
14	0.295	46.59	0.08	46.67	60.38	-13.71	QP
15	0.444	38.50	0.08	38.58	46.99	-8.41	Average
16	0.444	50.24	0.08	50.32	56.99	-6.67	QP
17	0.535	36.55	0.09	36.64	46.00	-9.36	Average
18	0.535	48.29	0.09	48.38	56.00	-7.62	QP

Notes:

1. Result = Read Value + Factor
2. Factor = LISN Factor + Cable Loss
3. According to technical experiences, all spurious emission of BT mode at channel 0,39,78 are almost the same below 1GHz, so that the channel 0 was chosen as representative in final test.
4. The data is worst case.



Power	: AC 120V	Pol/Phase	: LINE
Test Mode	: $\pi/4$ -DQPSK CH0	Temperature	: 25 °C
Memo	: Adapter: CWT \ KPC-010B	Humidity	: 50 %

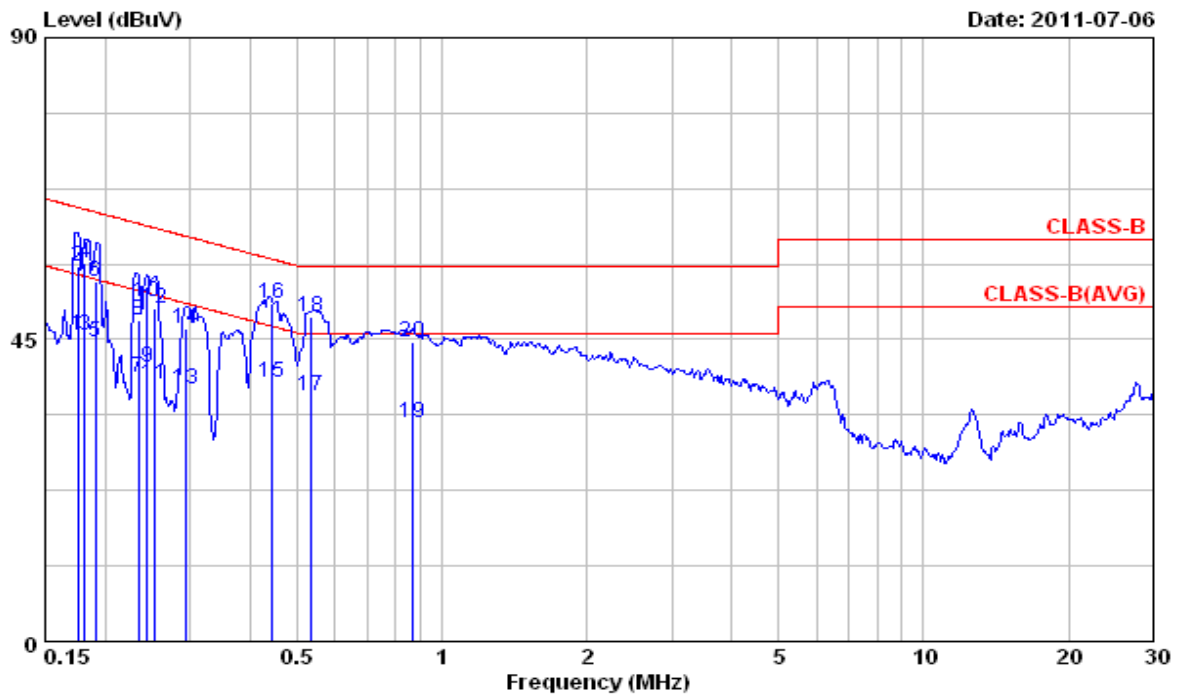

Item	Freq	Read Value	Factor	Result	Limit	Margin	Remark
	MHz	dBuV	dB/m	dBuV/m	dBuV/m	dB	
19	0.865	32.53	0.10	32.63	46.00	-13.37	Average
20	0.865	44.41	0.10	44.51	56.00	-11.49	QP

Notes:

1. Result = Read Value + Factor
2. Factor = LISN Factor + Cable Loss
3. According to technical experiences, all spurious emission of BT mode at channel 0,39,78 are almost the same below 1GHz, so that the channel 0 was chosen as representative in final test.
4. The data is worst case.



Power	: AC 120V	Pol/Phase	: NEUTRAL
Test Mode	: $\pi/4$ -DQPSK CH0	Temperature	: 25 °C
Memo	: Adapter: CWT \ KPC-010B	Humidity	: 50 %

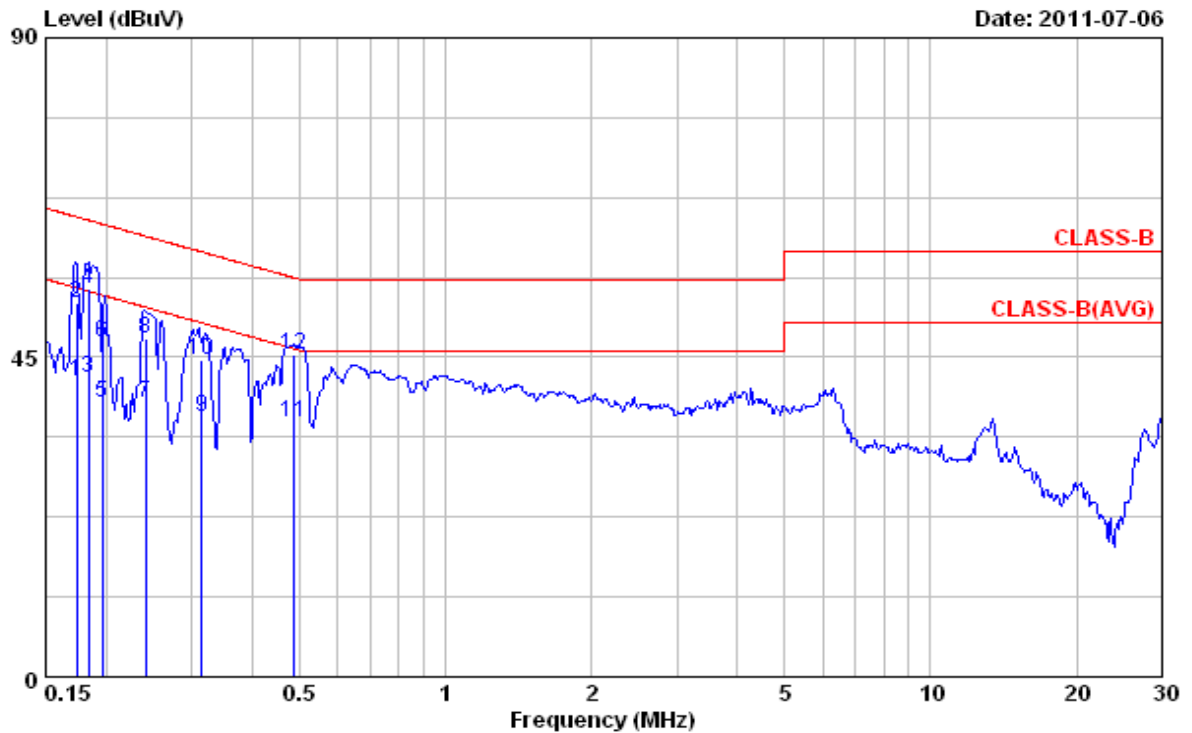

Item	Freq MHz	Read Value dBuV	Factor dB/m	Result dBuV/m	Limit dBuV/m	Margin dB	Remark
1	0.174	41.55	0.07	41.62	54.76	-13.14	Average
2	0.174	52.56	0.07	52.63	64.76	-12.13	QP
3	0.183	42.13	0.07	42.20	54.33	-12.13	Average
4	0.183	54.67	0.07	54.74	64.33	-9.59	QP
5	0.196	38.65	0.07	38.72	53.77	-15.05	Average
6	0.196	47.02	0.07	47.09	63.77	-16.68	QP
7	0.241	38.52	0.07	38.59	52.07	-13.48	Average
8	0.241	47.51	0.07	47.58	62.07	-14.49	QP
9	0.314	36.43	0.08	36.51	49.87	-13.36	Average
10	0.314	44.59	0.08	44.67	59.87	-15.20	QP
11	0.488	35.65	0.08	35.73	46.21	-10.48	Average
12	0.488	45.26	0.08	45.34	56.21	-10.87	QP

Notes:

1. Result = Read Value + Factor
2. Factor = LISN Factor + Cable Loss
3. According to technical experiences, all spurious emission of BT mode at channel 0,39,78 are almost the same below 1GHz, so that the channel 0 was chosen as representative in final test.
4. The data is worst case.



Power	: AC 120V	Pol/Phase	: LINE
Test Mode	: 8DPSK CH0	Temperature	: 25 °C
Memo	: Adapter: CWT \ KPC-010B	Humidity	: 50 %

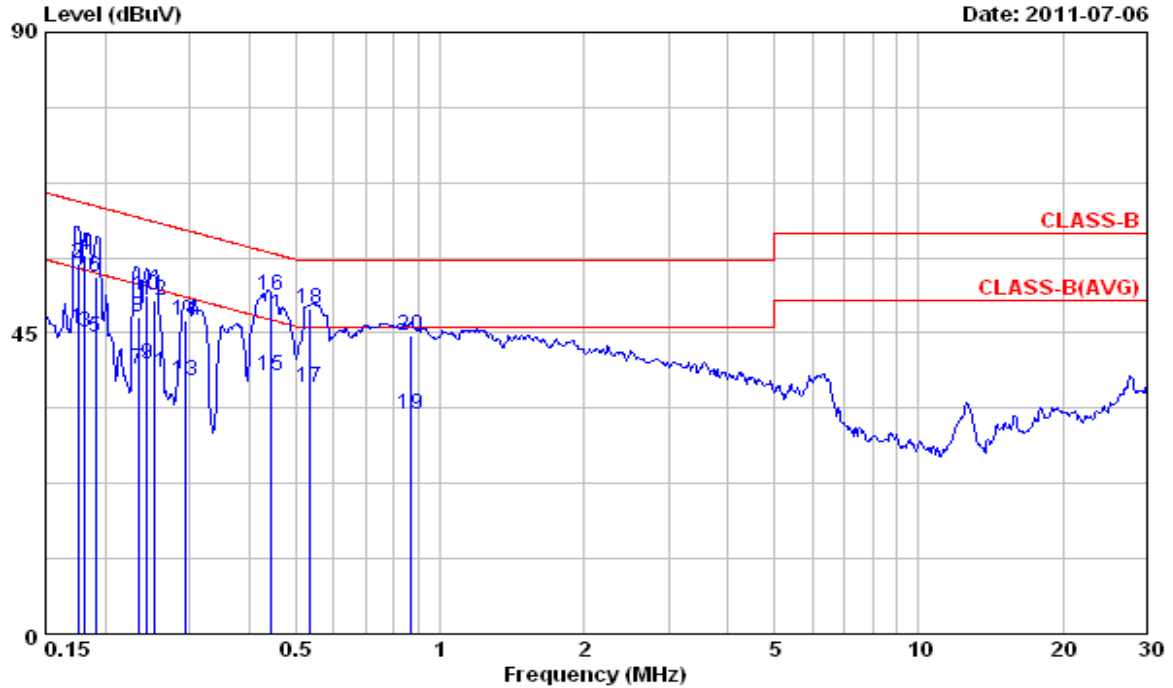

Item	Freq	Read Value	Factor	Result	Limit	Margin	Remark
	MHz	dBuV	dB/m	dBuV/m	dBuV/m	dB	
1	0.175	45.68	0.07	45.75	54.70	-8.95	Average
2	0.175	55.32	0.07	55.39	64.70	-9.31	QP
3	0.182	45.10	0.07	45.17	54.41	-9.24	Average
4	0.182	56.69	0.07	56.76	64.41	-7.65	QP
5	0.191	44.33	0.07	44.40	54.01	-9.61	Average
6	0.191	53.45	0.07	53.52	64.01	-10.49	QP
7	0.234	39.63	0.07	39.70	52.30	-12.60	Average
8	0.234	47.36	0.07	47.43	62.30	-14.87	QP
9	0.244	40.33	0.07	40.40	51.95	-11.55	Average
10	0.244	50.65	0.07	50.72	61.95	-11.23	QP
11	0.252	38.95	0.07	39.02	51.69	-12.67	Average
12	0.252	49.87	0.07	49.94	61.69	-11.75	QP
13	0.295	37.86	0.08	37.94	50.38	-12.44	Average
14	0.295	46.69	0.08	46.77	60.38	-13.61	QP
15	0.444	38.50	0.08	38.58	46.99	-8.41	Average
16	0.444	50.64	0.08	50.72	56.99	-6.27	QP
17	0.535	36.68	0.09	36.77	46.00	-9.23	Average
18	0.535	48.59	0.09	48.68	56.00	-7.32	QP

Notes:

1. Result = Read Value + Factor
2. Factor = LISN Factor + Cable Loss
3. According to technical experiences, all spurious emission of BT mode at channel 0,39,78 are almost the same below 1GHz, so that the channel 0 was chosen as representative in final test.
4. The data is worst case.



Power	: AC 120V	Pol/Phase	: LINE
Test Mode	: 8DPSK CH0	Temperature	: 25 °C
Memo	: Adapter: CWT \ KPC-010B	Humidity	: 50 %

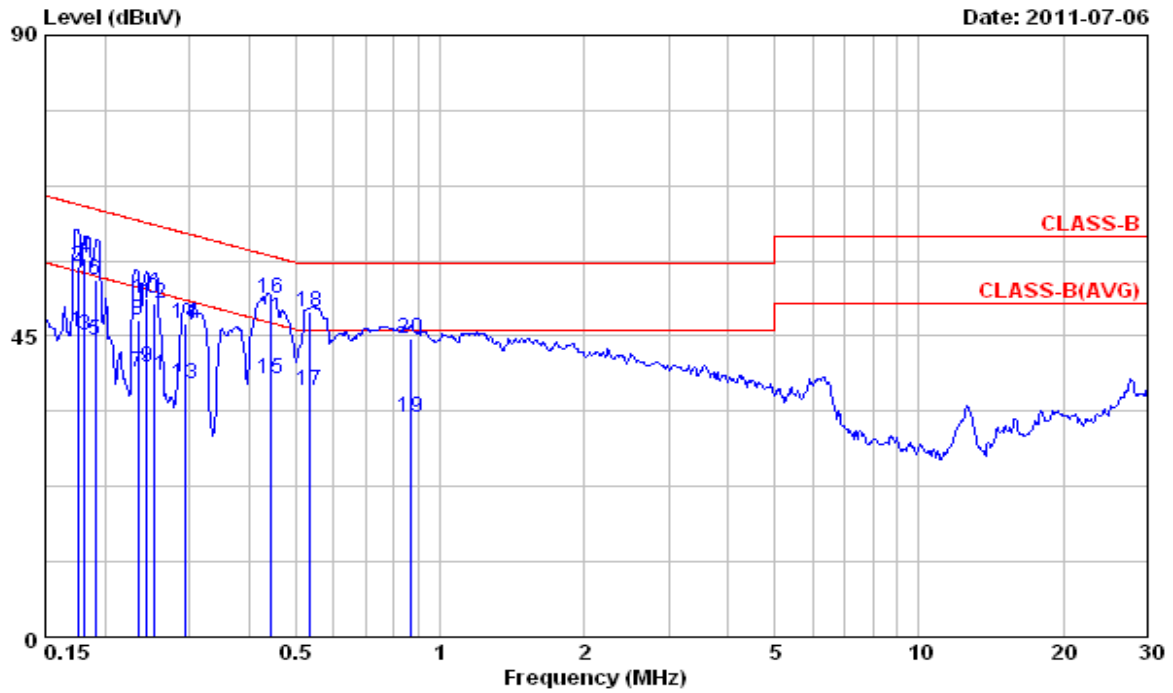

Item	Freq	Read Value	Factor	Result	Limit	Margin	Remark
	MHz	dBuV	dB/m	dBuV/m	dBuV/m	dB	
19	0.865	32.83	0.10	32.93	46.00	-13.07	Average
20	0.865	44.41	0.10	44.51	56.00	-11.49	QP

Notes:

1. Result = Read Value + Factor
2. Factor = LISN Factor + Cable Loss
3. According to technical experiences, all spurious emission of BT mode at channel 0,39,78 are almost the same below 1GHz, so that the channel 0 was chosen as representative in final test.
4. The data is worst case.



Power	: AC 120V	Pol/Phase	: NEUTRAL
Test Mode	: 8DPSK CH0	Temperature	: 25 °C
Memo	: Adapter: CWT \ KPC-010B	Humidity	: 50 %

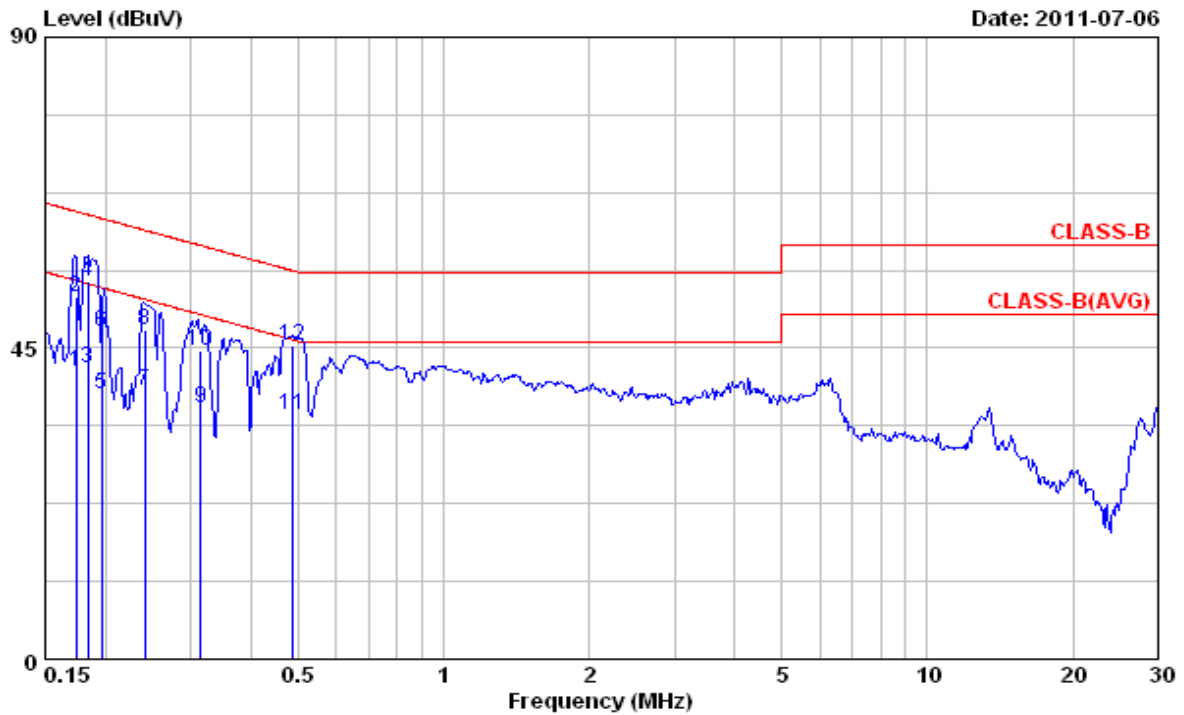

Item	Freq	Read Value	Factor	Result	Limit	Margin	Remark
	MHz	dBuV	dB/m	dBuV/m	dBuV/m	dB	
1	0.174	41.56	0.07	41.63	54.76	-13.13	Average
2	0.174	52.26	0.07	52.33	64.76	-12.43	QP
3	0.183	42.13	0.07	42.20	54.33	-12.13	Average
4	0.183	54.57	0.07	54.64	64.33	-9.69	QP
5	0.196	38.25	0.07	38.32	53.77	-15.45	Average
6	0.196	47.32	0.07	47.39	63.77	-16.38	QP
7	0.241	38.82	0.07	38.89	52.07	-13.18	Average
8	0.241	47.61	0.07	47.68	62.07	-14.39	QP
9	0.314	36.33	0.08	36.41	49.87	-13.46	Average
10	0.314	44.67	0.08	44.75	59.87	-15.12	QP
11	0.488	35.15	0.08	35.23	46.21	-10.98	Average
12	0.488	45.26	0.08	45.34	56.21	-10.87	QP

Notes:

1. Result = Read Value + Factor
2. Factor = LISN Factor + Cable Loss
3. According to technical experiences, all spurious emission of BT mode at channel 0,39,78 are almost the same below 1GHz, so that the channel 0 was chosen as representative in final test.
4. The data is worst case.



Power	: AC 120V	Pol/Phase	: LINE
Test Mode	: GFSK CH0	Temperature	: 25 °C
Memo	: Adapter: Touch \ M8-10US05R	Humidity	: 50 %

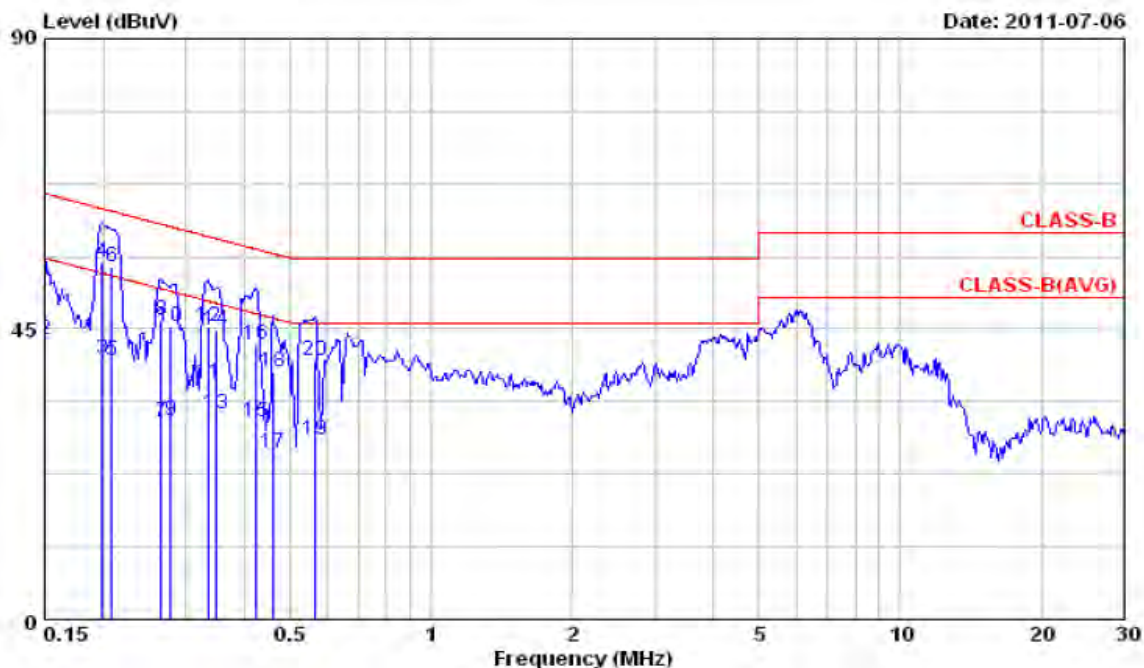

Item	Freq	Read Value	Factor	Result	Limit	Margin	Remark
	MHz	dBuV	dB/m	dBuV/m	dBuV/m	dB	
1	0.150	27.03	0.07	27.10	55.99	-28.89	Average
2	0.150	43.36	0.07	43.43	65.99	-22.56	QP
3	0.199	40.35	0.07	40.42	53.64	-13.22	Average
4	0.199	55.42	0.07	55.49	63.64	-8.15	QP
5	0.208	39.98	0.07	40.05	53.27	-13.22	Average
6	0.208	54.64	0.07	54.71	63.27	-8.56	QP
7	0.266	30.63	0.07	30.70	51.25	-20.55	Average
8	0.266	46.28	0.07	46.35	61.25	-14.90	QP
9	0.278	30.88	0.07	30.95	50.87	-19.92	Average
10	0.278	45.33	0.07	45.40	60.87	-15.47	QP
11	0.334	36.44	0.08	36.52	49.36	-12.84	Average
12	0.334	45.26	0.08	45.34	59.36	-14.02	QP
13	0.349	31.84	0.08	31.92	48.99	-17.07	Average
14	0.349	44.74	0.08	44.82	58.99	-14.17	QP
15	0.424	30.43	0.08	30.51	47.37	-16.86	Average
16	0.424	42.66	0.08	42.74	57.37	-14.63	QP
17	0.462	25.71	0.08	25.79	46.65	-20.86	Average
18	0.462	38.27	0.08	38.35	56.65	-18.30	QP

Notes:

1. Result = Read Value + Factor
2. Factor = LISN Factor + Cable Loss
3. According to technical experiences, all spurious emission of BT mode at channel 0,39,78 are almost the same below 1GHz, so that the channel 0 was chosen as representative in final test.
4. The data is worst case.



Power	: AC 120V	Pol/Phase	: LINE
Test Mode	: GFSK CH0	Temperature	: 25 °C
Memo	: Adapter: Touch \ M8-10US05R	Humidity	: 50 %

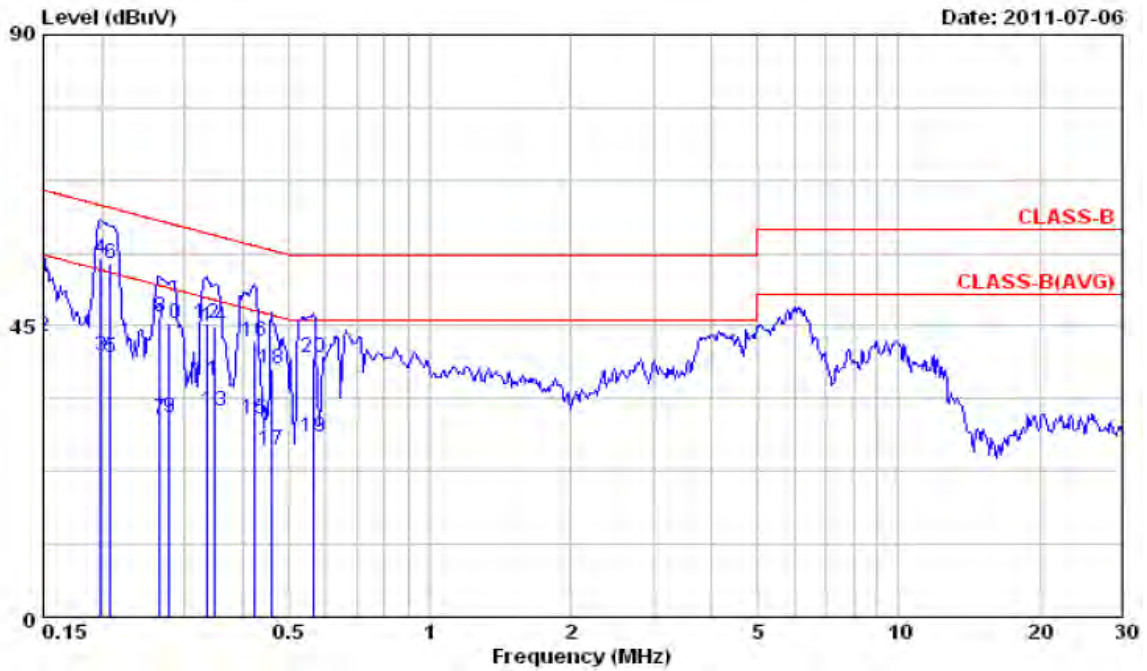

Item	Freq	Read Value	Factor	Result	Limit	Margin	Remark
	MHz	dBuV	dB/m	dBuV/m	dBuV/m	dB	
19	0.564	27.72	0.09	27.81	46.00	-18.19	Average
20	0.564	39.98	0.09	40.07	56.00	-15.93	QP

Notes:

1. Result = Read Value + Factor
2. Factor = LISN Factor + Cable Loss
3. According to technical experiences, all spurious emission of BT mode at channel 0,39,78 are almost the same below 1GHz, so that the channel 0 was chosen as representative in final test.
4. The data is worst case.



Power	: AC 120V	Pol/Phase	: NEUTRAL
Test Mode	: GFSK CH0	Temperature	: 25 °C
Memo	: Adapter: Touch \ M8-10US05R	Humidity	: 50 %

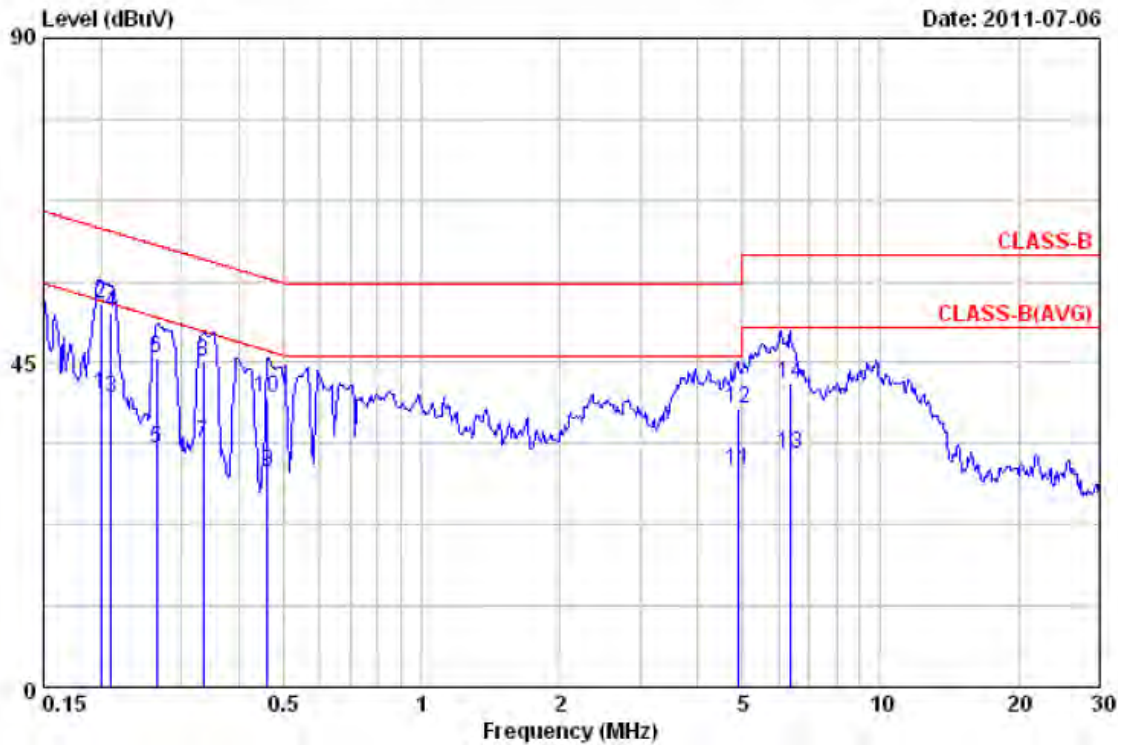

Item	Freq	Read Value	Factor	Result	Limit	Margin	Remark
	MHz	dBuV	dB/m	dBuV/m	dBuV/m	dB	
1	0.200	40.51	0.07	40.58	53.63	-13.05	Average
2	0.200	53.12	0.07	53.19	63.63	-10.44	QP
3	0.211	40.04	0.07	40.11	53.18	-13.07	Average
4	0.211	51.84	0.07	51.91	63.18	-11.27	QP
5	0.264	32.98	0.07	33.05	51.29	-18.24	Average
6	0.264	45.58	0.07	45.65	61.29	-15.64	QP
7	0.335	33.87	0.08	33.95	49.33	-15.38	Average
8	0.335	44.96	0.08	45.04	59.33	-14.29	QP
9	0.462	29.71	0.08	29.79	46.66	-16.87	Average
10	0.462	40.02	0.08	40.10	56.66	-16.56	QP
11	4.884	29.93	0.23	30.16	46.00	-15.84	Average
12	4.884	38.48	0.23	38.71	56.00	-17.29	QP
13	6.378	32.16	0.27	32.43	50.00	-17.57	Average
14	6.378	41.90	0.27	42.17	60.00	-17.83	QP

Notes:

1. Result = Read Value + Factor
2. Factor = LISN Factor + Cable Loss
3. According to technical experiences, all spurious emission of BT mode at channel 0,39,78 are almost the same below 1GHz, so that the channel 0 was chosen as representative in final test.
4. The data is worst case.



Power	: AC 120V	Pol/Phase	: LINE
Test Mode	: $\pi/4$ -DQPSK CH0	Temperature	: 25 °C
Memo	: Adapter: Touch \ M8-10US05R	Humidity	: 50 %

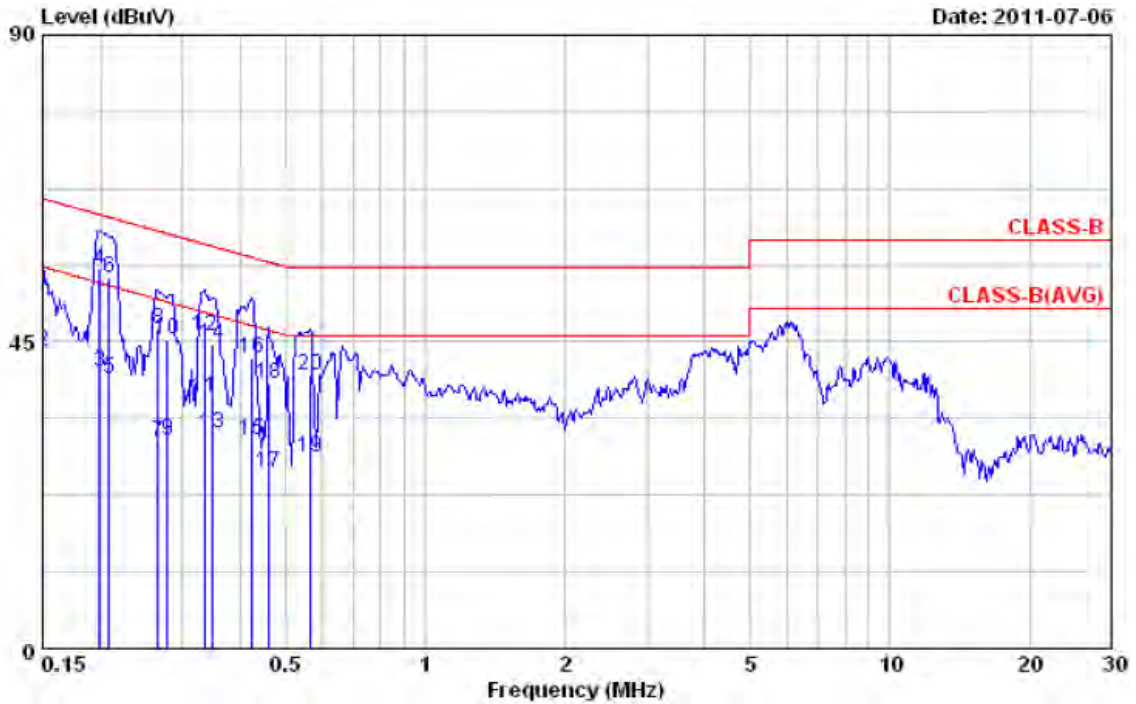

Item	Freq	Read Value	Factor	Result	Limit	Margin	Remark
	MHz	dBuV	dB/m	dBuV/m	dBuV/m	dB	
1	0.150	27.47	0.07	27.54	55.99	-28.45	Average
2	0.150	43.66	0.07	43.73	65.99	-22.26	QP
3	0.199	40.51	0.07	40.58	53.64	-13.06	Average
4	0.199	55.68	0.07	55.75	63.64	-7.89	QP
5	0.208	39.50	0.07	39.57	53.27	-13.70	Average
6	0.208	54.42	0.07	54.49	63.27	-8.78	QP
7	0.266	30.29	0.07	30.36	51.25	-20.89	Average
8	0.266	46.69	0.07	46.76	61.25	-14.49	QP
9	0.278	30.57	0.07	30.64	50.87	-20.23	Average
10	0.278	45.39	0.07	45.46	60.87	-15.41	QP
11	0.334	36.67	0.08	36.75	49.36	-12.61	Average
12	0.334	45.80	0.08	45.88	59.36	-13.48	QP
13	0.349	31.38	0.08	31.46	48.99	-17.53	Average
14	0.349	44.57	0.08	44.65	58.99	-14.34	QP
15	0.424	30.47	0.08	30.55	47.37	-16.82	Average
16	0.424	42.48	0.08	42.56	57.37	-14.81	QP
17	0.462	25.76	0.08	25.84	46.65	-20.81	Average
18	0.462	38.66	0.08	38.74	56.65	-17.91	QP

Notes:

1. Result = Read Value + Factor
2. Factor = LISN Factor + Cable Loss
3. According to technical experiences, all spurious emission of BT mode at channel 0,39,78 are almost the same below 1GHz, so that the channel 0 was chosen as representative in final test.
4. The data is worst case.



Power	: AC 120V	Pol/Phase	: LINE
Test Mode	: $\pi/4$ -DQPSK CH0	Temperature	: 25 °C
Memo	: Adapter: Touch \ M8-10US05R	Humidity	: 50 %

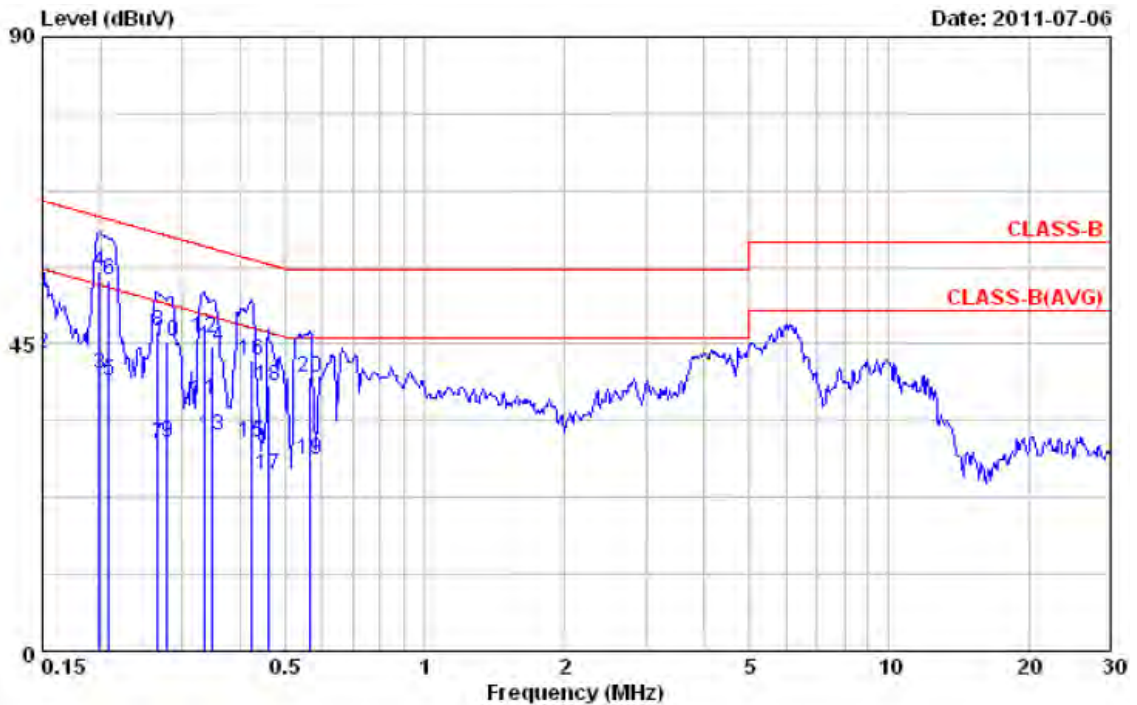

Item	Freq	Read Value	Factor	Result	Limit	Margin	Remark
	MHz	dBuV	dB/m	dBuV/m	dBuV/m	dB	
19	0.564	27.89	0.09	27.98	46.00	-18.02	Average
20	0.564	39.92	0.09	40.01	56.00	-15.99	QP

Notes:

1. Result = Read Value + Factor
2. Factor = LISN Factor + Cable Loss
3. According to technical experiences, all spurious emission of BT mode at channel 0,39,78 are almost the same below 1GHz, so that the channel 0 was chosen as representative in final test.
4. The data is worst case.



Power	: AC 120V	Pol/Phase	: NEUTRAL
Test Mode	: $\pi/4$ -DQPSK CH0	Temperature	: 25 °C
Memo	: Adapter: Touch \ M8-10US05R	Humidity	: 50 %

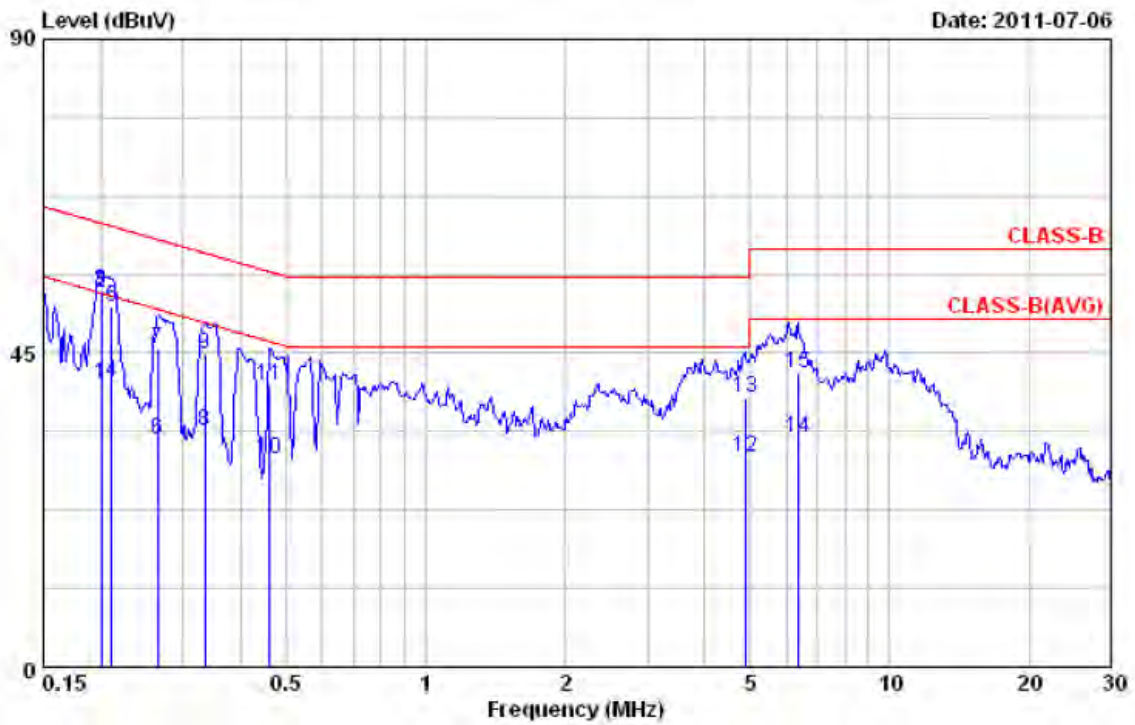

Item	Freq	Read Value	Factor	Result	Limit	Margin	Remark
	MHz	dBuV	dB/m	dBuV/m	dBuV/m	dB	
1	0.200	40.52	0.07	40.59	53.63	-13.04	Average
2	0.200	53.66	0.07	53.73	63.63	-9.90	QP
3	0.200	53.87	0.07	53.94	63.63	-9.69	QP
4	0.211	40.68	0.07	40.75	53.18	-12.43	Average
5	0.211	51.57	0.07	51.64	63.18	-11.54	QP
6	0.264	32.65	0.07	32.72	51.29	-18.57	Average
7	0.264	45.63	0.07	45.70	61.29	-15.59	QP
8	0.335	33.85	0.08	33.93	49.33	-15.40	Average
9	0.335	44.69	0.08	44.77	59.33	-14.56	QP
10	0.462	29.79	0.08	29.87	46.66	-16.79	Average
11	0.462	40.35	0.08	40.43	56.66	-16.23	QP
12	4.884	29.89	0.23	30.12	46.00	-15.88	Average
13	4.884	38.35	0.23	38.58	56.00	-17.42	QP
14	6.378	32.53	0.27	32.80	50.00	-17.20	Average
15	6.378	41.97	0.27	42.24	60.00	-17.76	QP

Notes:

1. Result = Read Value + Factor
2. Factor = LISN Factor + Cable Loss
3. According to technical experiences, all spurious emission of BT mode at channel 0,39,78 are almost the same below 1GHz, so that the channel 0 was chosen as representative in final test.
4. The data is worst case.



Power	: AC 120V	Pol/Phase	: LINE
Test Mode	: 8DPSK CH0	Temperature	: 25 °C
Memo	: Adapter: Touch \ M8-10US05R	Humidity	: 50 %

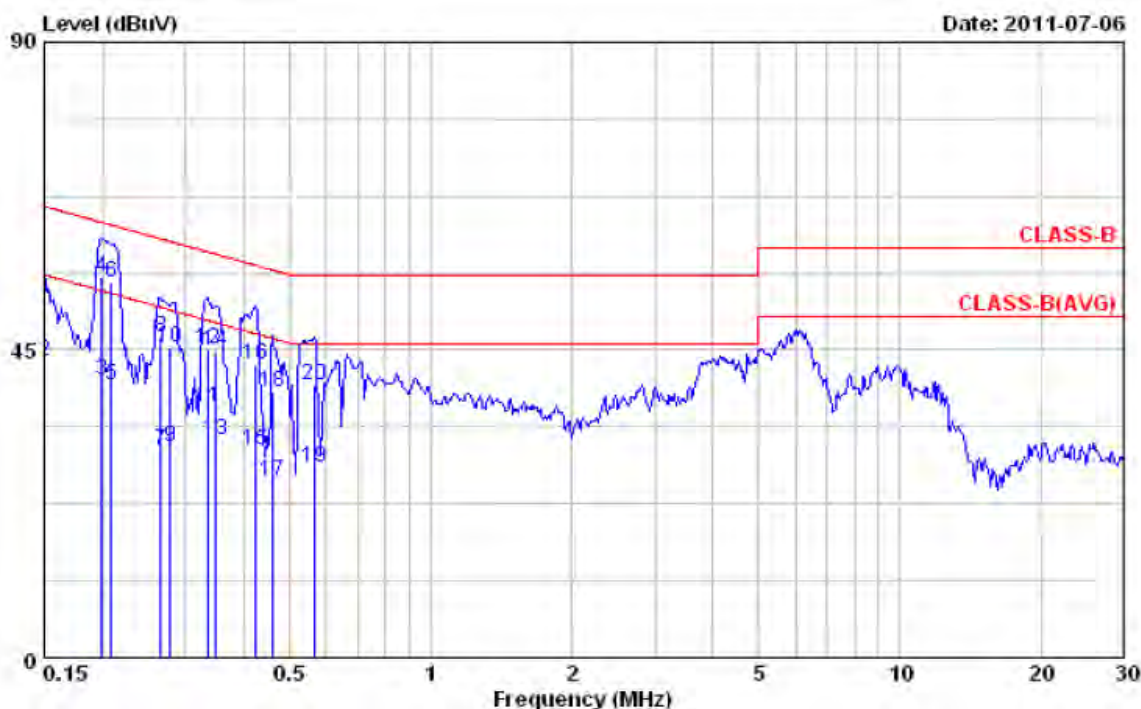

Item	Freq	Read Value	Factor	Result	Limit	Margin	Remark
	MHz	dBuV	dB/m	dBuV/m	dBuV/m	dB	
1	0.150	27.94	0.07	28.01	55.99	-27.98	Average
2	0.150	43.36	0.07	43.43	65.99	-22.56	QP
3	0.199	40.51	0.07	40.58	53.64	-13.06	Average
4	0.199	55.68	0.07	55.75	63.64	-7.89	QP
5	0.208	39.90	0.07	39.97	53.27	-13.30	Average
6	0.208	54.82	0.07	54.89	63.27	-8.38	QP
7	0.266	30.29	0.07	30.36	51.25	-20.89	Average
8	0.266	46.79	0.07	46.86	61.25	-14.39	QP
9	0.278	30.87	0.07	30.94	50.87	-19.93	Average
10	0.278	45.21	0.07	45.28	60.87	-15.59	QP
11	0.334	36.47	0.08	36.55	49.36	-12.81	Average
12	0.334	45.06	0.08	45.14	59.36	-14.22	QP
13	0.349	31.88	0.08	31.96	48.99	-17.03	Average
14	0.349	44.77	0.08	44.85	58.99	-14.14	QP
15	0.424	30.27	0.08	30.35	47.37	-17.02	Average
16	0.424	42.80	0.08	42.88	57.37	-14.49	QP
17	0.462	25.73	0.08	25.81	46.65	-20.84	Average
18	0.462	38.72	0.08	38.80	56.65	-17.85	QP

Notes:

1. Result = Read Value + Factor
2. Factor = LISN Factor + Cable Loss
3. According to technical experiences, all spurious emission of BT mode at channel 0,39,78 are almost the same below 1GHz, so that the channel 0 was chosen as representative in final test.
4. The data is worst case.



Power	: AC 120V	Pol/Phase	: LINE
Test Mode	: 8DPSK CH0	Temperature	: 25 °C
Memo	: Adapter: Touch \ M8-10US05R	Humidity	: 50 %

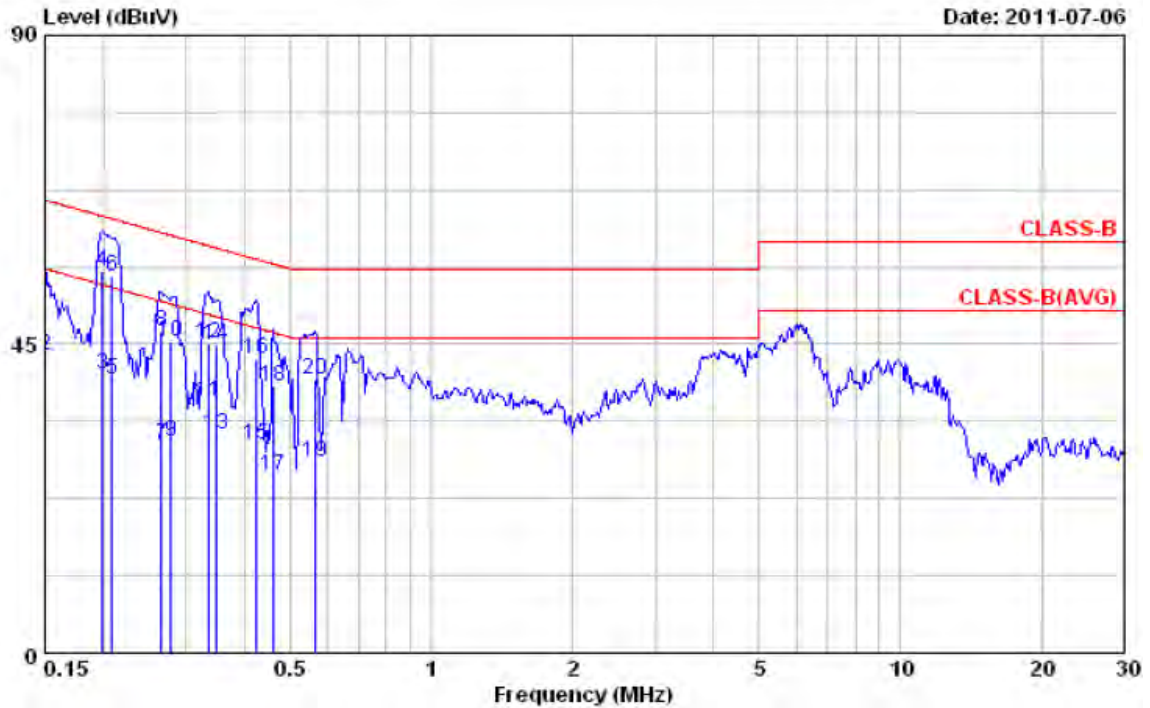

Item	Freq	Read Value	Factor	Result	Limit	Margin	Remark
	MHz	dBuV	dB/m	dBuV/m	dBuV/m	dB	
19	0.564	27.62	0.09	27.71	46.00	-18.29	Average
20	0.564	39.82	0.09	39.91	56.00	-16.09	QP

Notes:

1. Result = Read Value + Factor
2. Factor = LISN Factor + Cable Loss
3. According to technical experiences, all spurious emission of BT mode at channel 0,39,78 are almost the same below 1GHz, so that the channel 0 was chosen as representative in final test.
4. The data is worst case.



Power	: AC 120V	Pol/Phase	: NEUTRAL
Test Mode	: 8DPSK CH0	Temperature	: 25 °C
Memo	: Adapter: Touch \ M8-10US05R	Humidity	: 50 %

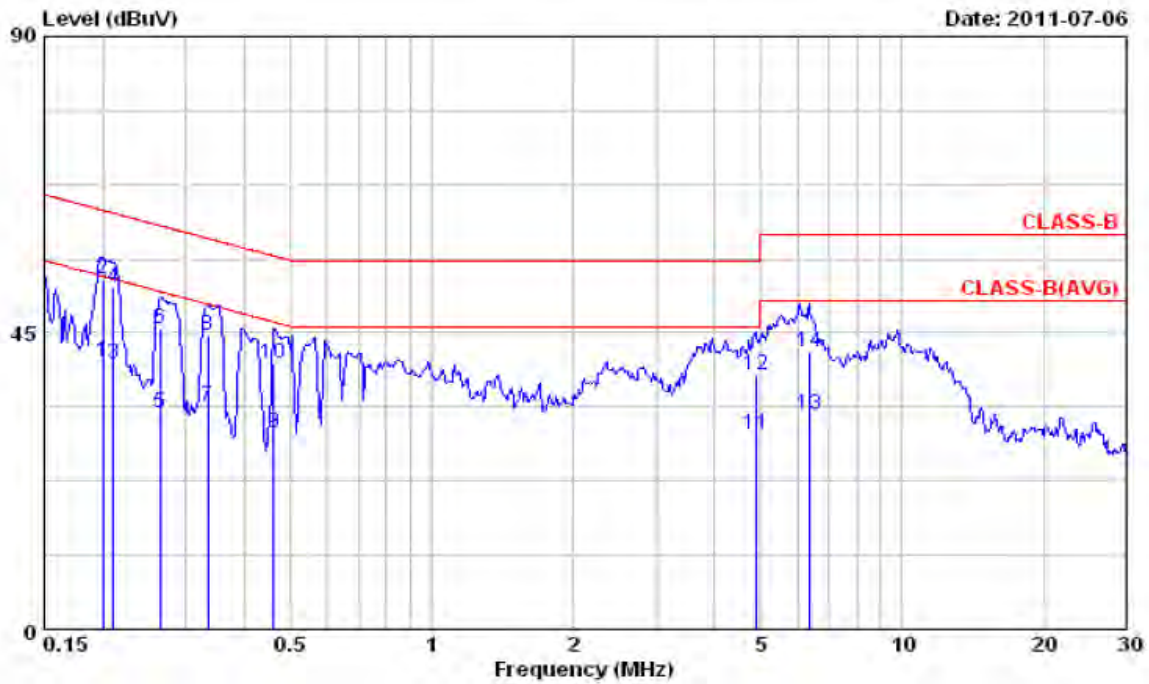

Item	Freq	Read Value	Factor	Result	Limit	Margin	Remark
	MHz	dBuV	dB/m	dBuV/m	dBuV/m	dB	
1	0.200	40.59	0.07	40.66	53.63	-12.97	Average
2	0.200	53.19	0.07	53.26	63.63	-10.37	QP
3	0.211	40.38	0.07	40.45	53.18	-12.73	Average
4	0.211	51.87	0.07	51.94	63.18	-11.24	QP
5	0.264	32.72	0.07	32.79	51.29	-18.50	Average
6	0.264	45.53	0.07	45.60	61.29	-15.69	QP
7	0.335	33.85	0.08	33.93	49.33	-15.40	Average
8	0.335	44.66	0.08	44.74	59.33	-14.59	QP
9	0.462	29.79	0.08	29.87	46.66	-16.79	Average
10	0.462	40.35	0.08	40.43	56.66	-16.23	QP
11	4.884	29.38	0.23	29.61	46.00	-16.39	Average
12	4.884	38.45	0.23	38.68	56.00	-17.32	QP
13	6.378	32.33	0.27	32.60	50.00	-17.40	Average
14	6.378	41.97	0.27	42.24	60.00	-17.76	QP

Notes:

1. Result = Read Value + Factor
2. Factor = LISN Factor + Cable Loss
3. According to technical experiences, all spurious emission of BT mode at channel 0,39,78 are almost the same below 1GHz, so that the channel 0 was chosen as representative in final test.
4. The data is worst case.

Test engineer: Ben



5. Test of Radiated Emission

5.1 Test Limit

Radiated emissions from 30 MHz to 25 GHz were measured according to the methods defines in ANSI C63.4-2003. The EUT was placed, 0.8 meter above the ground plane, as shown in section 5.6.3. The interface cables and equipment positions were varied within limits of reasonable applications to determine the positions producing maximum radiated emissions For unintentional device, according to § 15.109(a), except for Class A digital devices, the field strength of radiated emissions from unintentional radiators at a distance of 3 meters shall not exceed the following values:

Frequency (MHz)	Distance Meters	Radiated (μ V / M)	Radiated (dB μ V / M)
30-88	3	100	40.0
88-216	3	150	43.5
216-960	3	200	46.0
Above 960	3	500	54.0

For unintentional device, according to CISPR PUB.22, for Class B digital devices, the general requirement of field strength of radiated emissions from intentional radiators at a distance of 10 meters shall not exceed the above table.

Frequency (MHz)	Distance Meters	Radiated (dB μ V / M)
30-230	10	30
230-1000	10	37

5.2 Test Procedures

- The EUT was placed on a rotatable table top 0.8 meter above ground.
- The EUT was set 3 meters from the interference receiving antenna which was mounted on the top of a variable height antenna tower.
- The table was rotated 360 degrees to determine the position of the highest radiation.
- The antenna is a broadband antenna and its height is varied between one meter and four meters above ground to find the maximum value of the field strength both horizontal polarization and vertical polarization of the antenna are set to make the measurement.
- For each suspected emission the EUT was arranged to its worst case and then tune the antenna tower (from 1 M to 4 M) and turn table (from 0 degree to 360 degrees) to find the maximum reading.
- Set the test-receiver system to Peak or CISPR quasi-peak Detect Function and specified bandwidth with Maximum Hold Mode.
- If the emission level of the EUT in peak mode was 3 dB lower than the limit specified, then testing will be stopped and peak values of EUT will be reported, otherwise, the emissions which do not have 3 dB margin will be repeated one by one using the quasi-peak method and reported.
- For testing above 1GHz, the emission level of the EUT in peak mode was 20dB lower than average limit (that means the emission level in peak mode also complies with the limit in average mode), then testing will be stopped and peak values of EUT will be reported, otherwise, the emissions will be measured in average mode again and reported.



5.3 Typical Test Setup

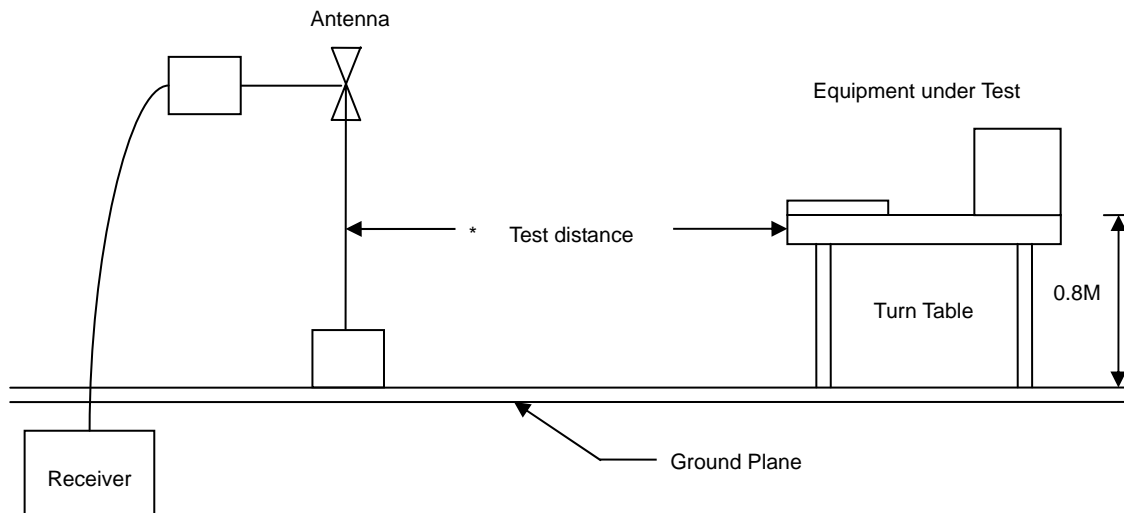

5.4 Measurement equipment

Instrument/Ancillary	Manufacturer	Model No.	Serial No.	Calibration Date	Valid Date
Amplifier	Agilent	8447D	2944A10531	2011/01/21	2012/01/20
Bilog Antenna	Schaffner	CBL6112D	22242	2011/02/09	2012/02/08
EMI Receiver	HP	8546A	3807A00454	2010/09/27	2011/09/26
RF Filter Section	HP	85460A	3704A00386	2010/09/27	2011/09/26
SPECTRUM ANALYZER	R&S	FSP40	100219	2010/11/05	2011/11/04
HORN ANTENNA	EMCO	3115	31589	2011/05/02	2012/05/01
Preamplifier	Agilent	8449B	3008A01954	2011/03/02	2012/03/01



5.5 Test Result and Data

Power	: AC 120V	Pol/Phase	: VERTICAL
Test Mode	: Transmit / Receive	Temperature	: 23 °C
Operation Channel	: 0	Humidity	: 65 %
Modulation Type	: GFSK	Atmospheric Pressure	: 1020 hPa
Memo	: Adapter: CWT \ KPC-010B	Rate	: 1 Mbps

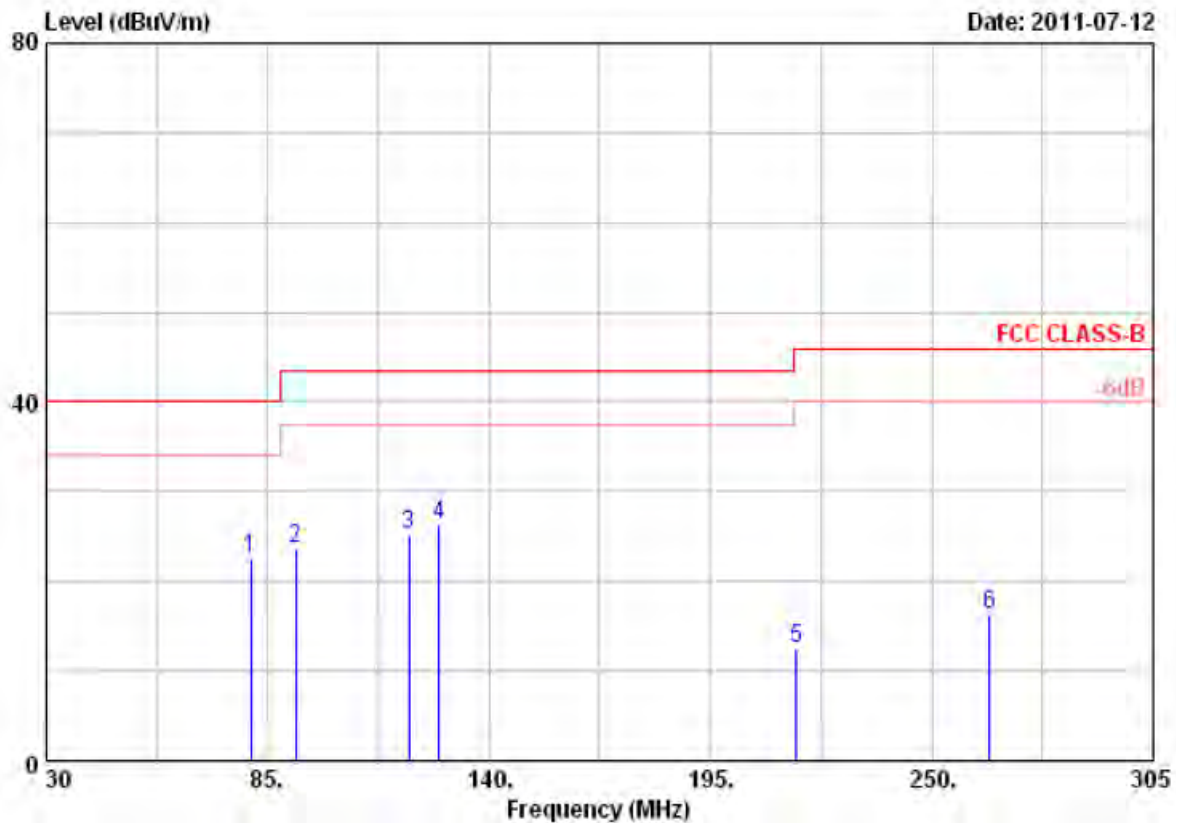

Item	Freq	Read Value	Factor	Result	Limit	Margin	Remark	Ant Pos	Tab Pos
	MHz	dBuV	dB/m	dBuV/m	dBuV/m	dB		cm	Deg
1	80.88	36.56	-13.95	22.61	40.00	-17.39	Peak	100	360
2	91.88	35.60	-11.89	23.71	43.50	-19.79	Peak	100	360
3	120.20	34.81	-9.73	25.08	43.50	-18.42	Peak	100	360
4	127.63	33.90	-7.52	26.38	43.50	-17.12	Peak	100	360
5	216.45	29.11	-16.57	12.54	46.00	-33.46	Peak	100	360
6	264.30	29.90	-13.74	16.16	46.00	-29.84	Peak	100	360

- Remarks:
1. Result = Read Value + Factor
 2. Factor = Antenna Factor + Cable Loss - Amplifier
 3. According to technical experiences, all spurious emission of BT mode at channel 0,39,78 are almost the same below 1GHz, so that the channel 0 was chosen as representative in final test.
 4. The data is worst case.



Power	: AC 120V	Pol/Phase	: VERTICAL
Test Mode	: Transmit / Receive	Temperature	: 23 °C
Operation Channel	: 0	Humidity	: 65 %
Modulation Type	: GFSK	Atmospheric Pressure	: 1020 hPa
Memo	: Adapter: CWT \ KPC-010B	Rate	: 1 Mbps

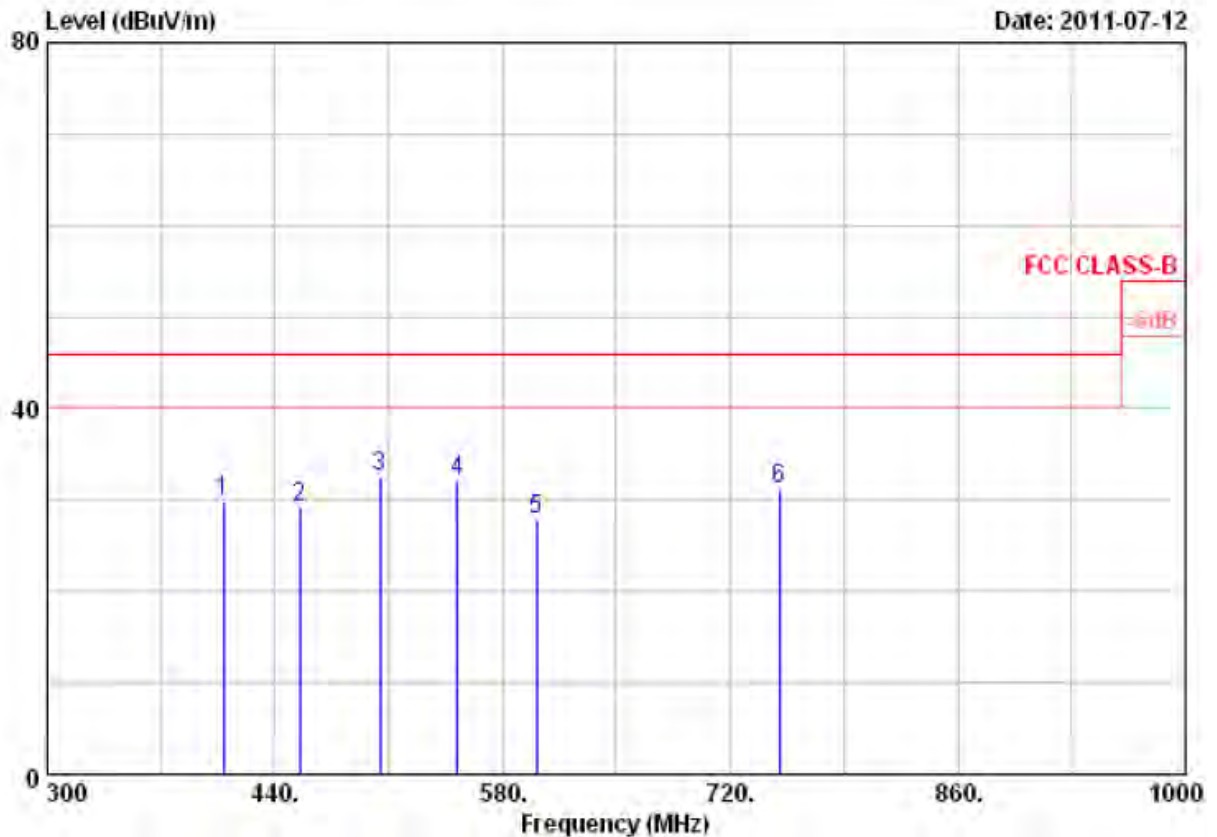

Item	Freq	Read Value	Factor	Result	Limit	Margin	Remark	Ant Pos	Tab Pos
	MHz	dBuV	dB/m	dBuV/m	dBuV/m	dB		cm	Deg
1	408.50	39.85	-10.09	29.76	46.00	-16.24	Peak	100	0
2	455.40	37.86	-8.59	29.27	46.00	-16.73	Peak	100	0
3	504.40	40.98	-8.46	32.52	46.00	-13.48	Peak	100	0
4	552.00	40.54	-8.38	32.16	46.00	-13.84	Peak	100	0
5	601.00	35.89	-8.02	27.87	46.00	-18.13	Peak	100	0
6	750.10	25.89	5.32	31.21	46.00	-14.79	Peak	100	0

Remarks: 1. Result = Read Value + Factor
 2. Factor = Antenna Factor + Cable Loss - Amplifier
 3. According to technical experiences, all spurious emission of BT mode at channel 0,39,78 are almost the same below 1GHz, so that the channel 0 was chosen as representative in final test.
 4. The data is worst case.



Power	: AC 120V	Pol/Phase	: HORIZONTAL
Test Mode	: Transmit / Receive	Temperature	: 23 °C
Operation Channel	: 0	Humidity	: 65 %
Modulation Type	: GFSK	Atmospheric Pressure	: 1020 hPa
Memo	: Adapter: CWT \ KPC-010B	Rate	: 1 Mbps

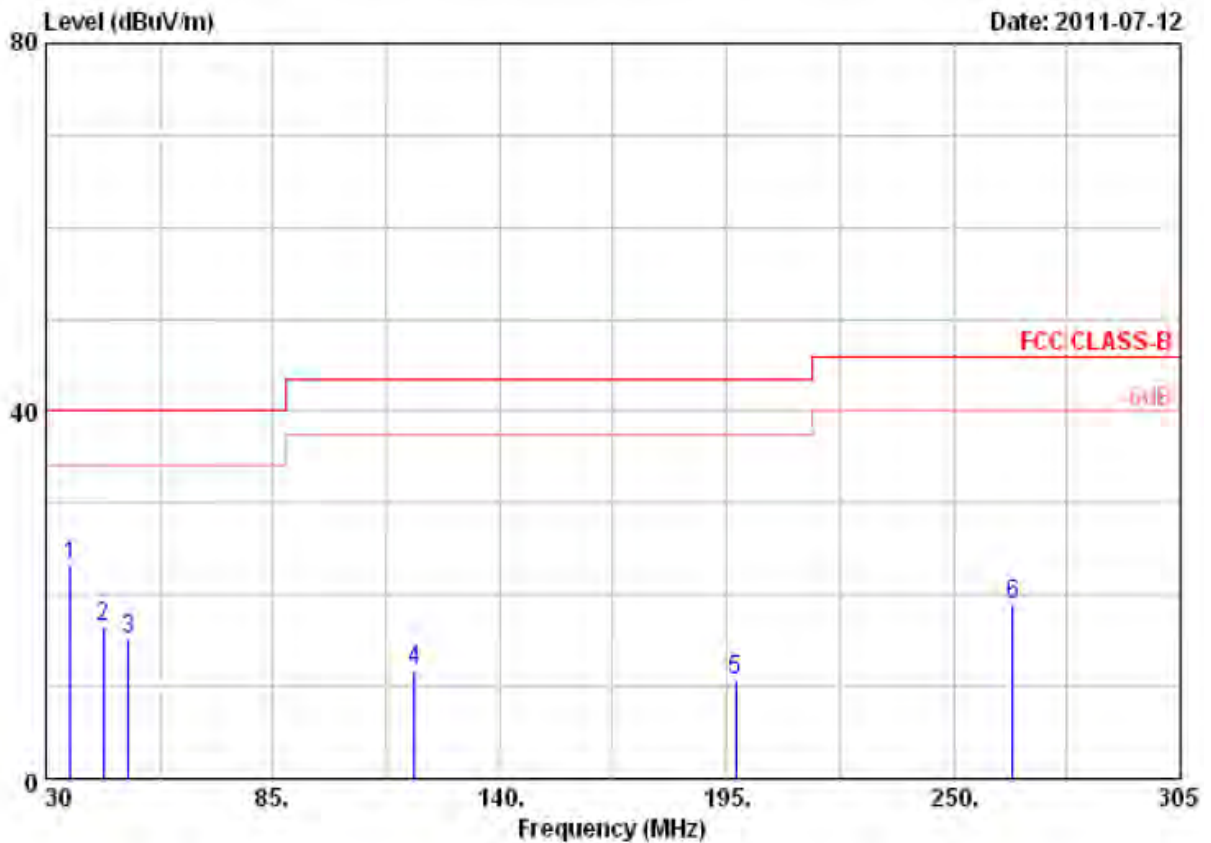

Item	Freq	Read Value	Factor	Result	Limit	Margin	Remark	Ant Pos	Tab Pos
	MHz	dBuV	dB/m	dBuV/m	dBuV/m	dB		cm	Deg
1	36.05	30.84	-7.76	23.08	40.00	-16.92	Peak	100	360
2	44.03	30.28	-13.89	16.39	40.00	-23.61	Peak	100	360
3	50.08	28.95	-13.84	15.11	40.00	-24.89	Peak	100	360
4	119.38	28.58	-16.79	11.79	43.50	-31.71	Peak	100	360
5	197.20	27.69	-16.91	10.78	43.50	-32.72	Peak	100	360
6	264.30	34.16	-15.13	19.03	46.00	-26.97	Peak	100	360

Remarks: 1. Result = Read Value + Factor
 2. Factor = Antenna Factor + Cable Loss - Amplifier
 3. According to technical experiences, all spurious emission of BT mode at channel 0,39,78 are almost the same below 1GHz, so that the channel 0 was chosen as representative in final test.
 4. The data is worst case.



Power	: AC 120V	Pol/Phase	: HORIZONTAL
Test Mode	: Transmit / Receive	Temperature	: 23 °C
Operation Channel	: 0	Humidity	: 65 %
Modulation Type	: GFSK	Atmospheric Pressure	: 1020 hPa
Memo	: Adapter: CWT \ KPC-010B	Rate	: 1 Mbps

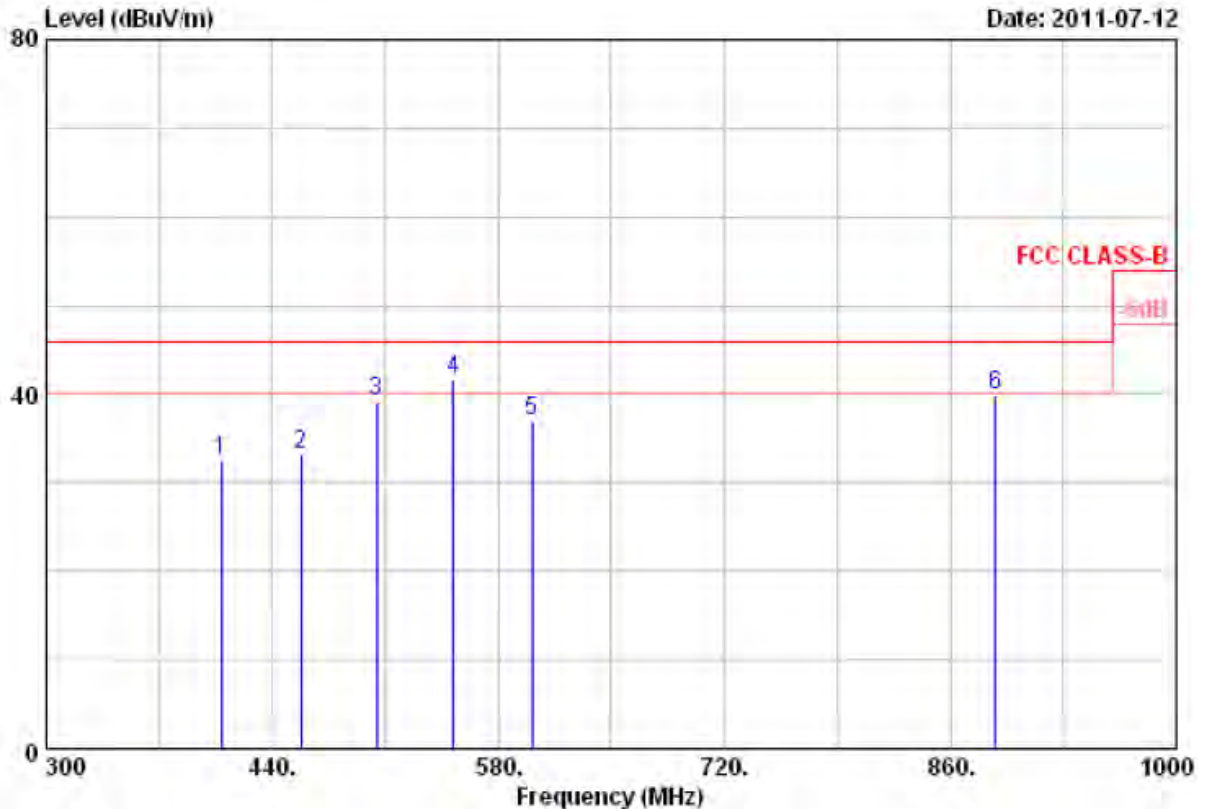

Item	Freq	Read Value	Factor	Result	Limit	Margin	Remark	Ant. Pos	Tab Pos
	MHz	dBuV	dB/m	dBuV/m	dBuV/m	dB		cm	Deg
1	408.50	42.84	-10.33	32.51	46.00	-13.49	Peak	100	0
2	457.50	41.38	-8.27	33.11	46.00	-12.89	Peak	100	0
3	504.40	43.66	-4.54	39.12	46.00	-6.88	Peak	100	0
4	552.00	42.52	-0.76	41.76	46.00	-4.24	QP	100	0
5	601.00	36.55	0.42	36.97	46.00	-9.03	Peak	100	0
6	888.00	29.60	10.34	39.94	46.00	-6.06	Peak	100	0

- Remarks:
1. Result = Read Value + Factor
 2. Factor = Antenna Factor + Cable Loss - Amplifier
 3. According to technical experiences, all spurious emission of BT mode at channel 0,39,78 are almost the same below 1GHz, so that the channel 0 was chosen as representative in final test.
 4. The data is worst case.



Power	: AC 120V	Pol/Phase	: VERTICAL
Test Mode	: Transmit / Receive	Temperature	: 25 °C
Operation Channel	: 0	Humidity	: 60 %
Modulation Type	: GFSK	Atmospheric Pressure	: 1020 hPa
Memo	: Adapter: CWT \ KPC-010B	Rate	: 1 Mbps

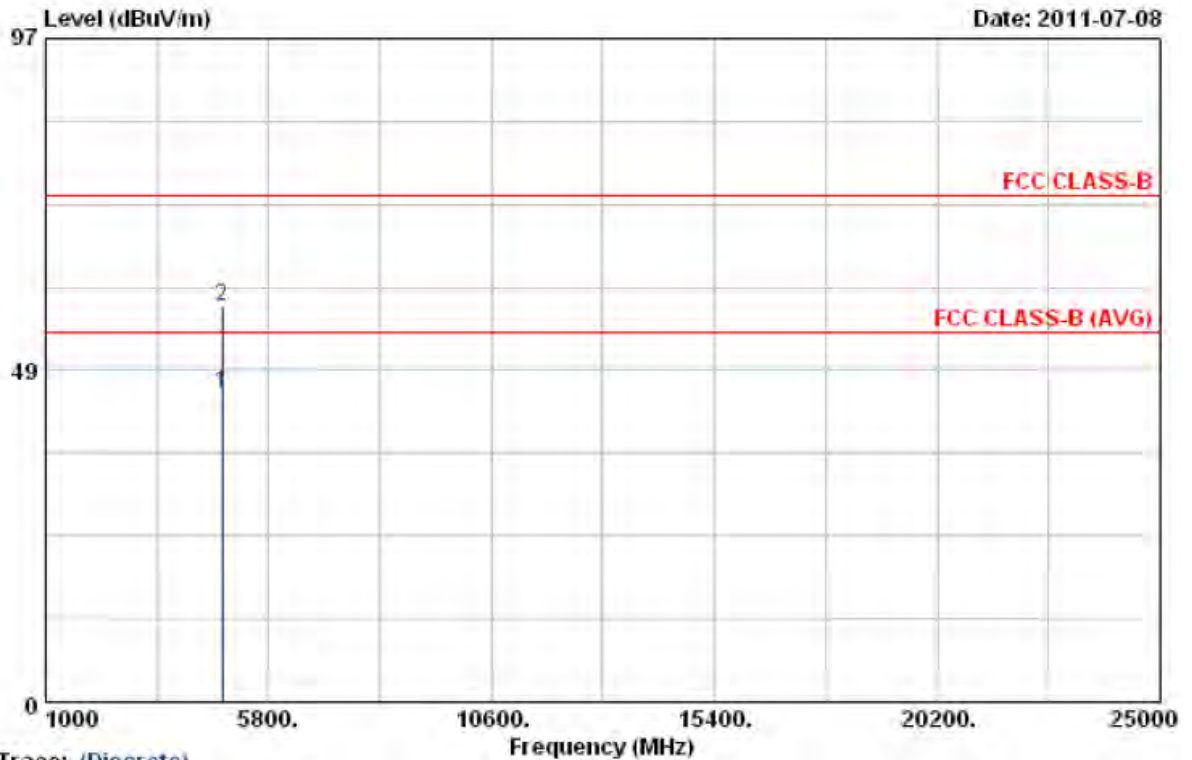

Trace: (Discrete)

Item	Freq	Read Value	Factor	Result	Limit	Margin	Remark	Ant Pos	Tab Pos
	MHz	dBuV	dB/m	dBuV/m	dBuV/m	dB		cm	Deg
1	4804.03	36.33	8.76	45.09	54.00	-8.91	Average	119	240
2	4804.03	48.99	8.76	57.75	74.00	-16.25	Peak	119	240

Notes:

1. Result = Read Value + Factor
2. Factor = Antenna Factor + Cable Loss - Amplifier
3. The resolution bandwidth of test receiver/spectrum analyzer is 120KHz and video bandwidth is 300kHz for Peak detection and Quasi-peak detection at frequency below 1GHz.
4. The resolution bandwidth of test receiver/spectrum analyzer is 1MHz and video bandwidth is 3MHz for Peak detection at frequency above 1GHz.
5. The resolution bandwidth of test receiver/spectrum analyzer is 1MHz and video bandwidth is 10Hz for Average detection at frequency above 1GHz.
6. The other emissions is too low to be measured.
7. The data is worse case.



Power	: AC 120V	Pol/Phase	: HORIZONTAL
Test Mode	: Transmit / Receive	Temperature	: 25 °C
Operation Channel	: 0	Humidity	: 60 %
Modulation Type	: GFSK	Atmospheric Pressure	: 1020 hPa
Memo	: Adapter: CWT \ KPC-010B	Rate	: 1 Mbps

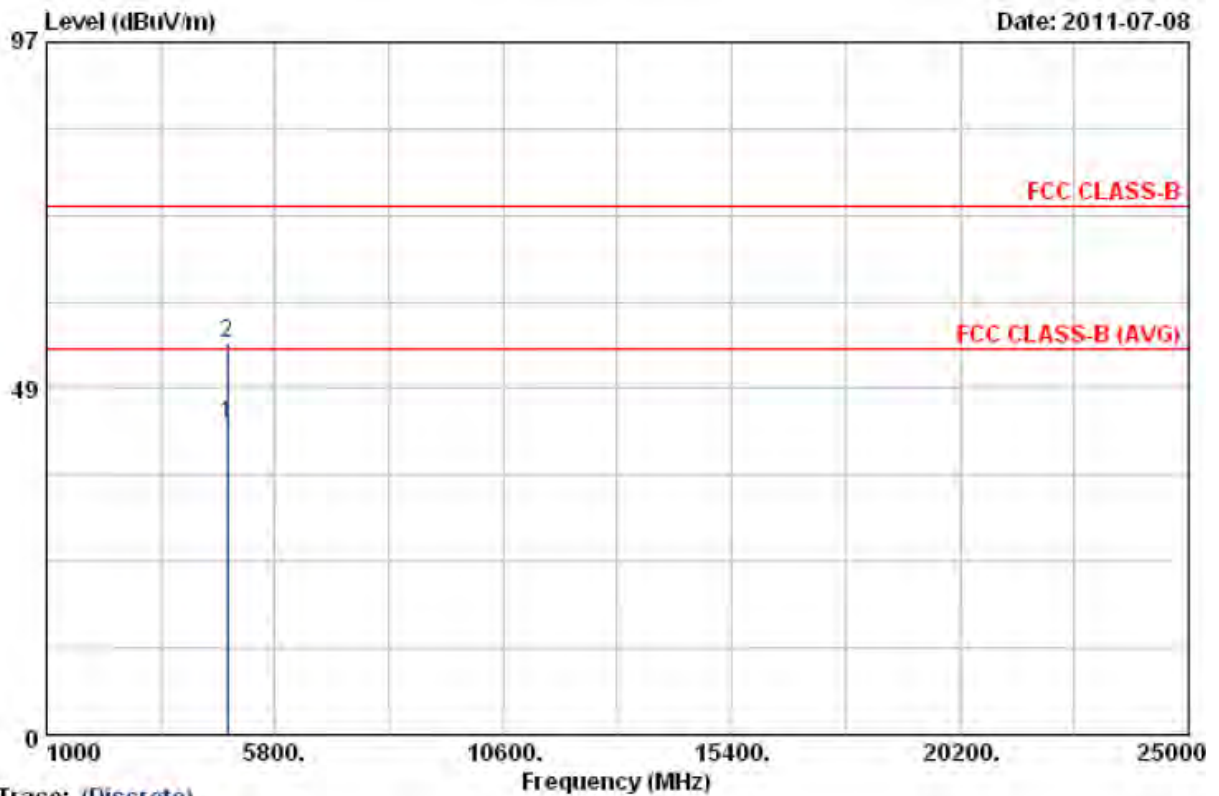

Trace: (Discrete)

Item	Freq	Read Value	Factor	Result	Limit	Margin	Remark	Ant Pos	Tab Pos
	MHz	dBuV	dB/m	dBuV/m	dBuV/m	dB		cm	Deg
1	4803.95	34.65	8.76	43.41	54.00	-10.59	Average	150	250
2	4803.95	46.22	8.76	54.98	74.00	-19.02	Peak	150	250

Notes:

1. Result = Read Value + Factor
2. Factor = Antenna Factor + Cable Loss - Amplifier
3. The resolution bandwidth of test receiver/spectrum analyzer is 120KHz and video bandwidth is 300kHz for Peak detection and Quasi-peak detection at frequency below 1GHz.
4. The resolution bandwidth of test receiver/spectrum analyzer is 1MHz and video bandwidth is 3MHz for Peak detection at frequency above 1GHz.
5. The resolution bandwidth of test receiver/spectrum analyzer is 1MHz and video bandwidth is 10Hz for Average detection at frequency above 1GHz.
6. The other emissions is too low to be measured.
7. The data is worse case.



Power	: AC 120V	Pol/Phase	: VERTICAL
Test Mode	: Transmit / Receive	Temperature	: 25 °C
Operation Channel	: 39	Humidity	: 60 %
Modulation Type	: GFSK	Atmospheric Pressure	: 1020 hPa
Memo	: Adapter: CWT \ KPC-010B	Rate	: 1 Mbps

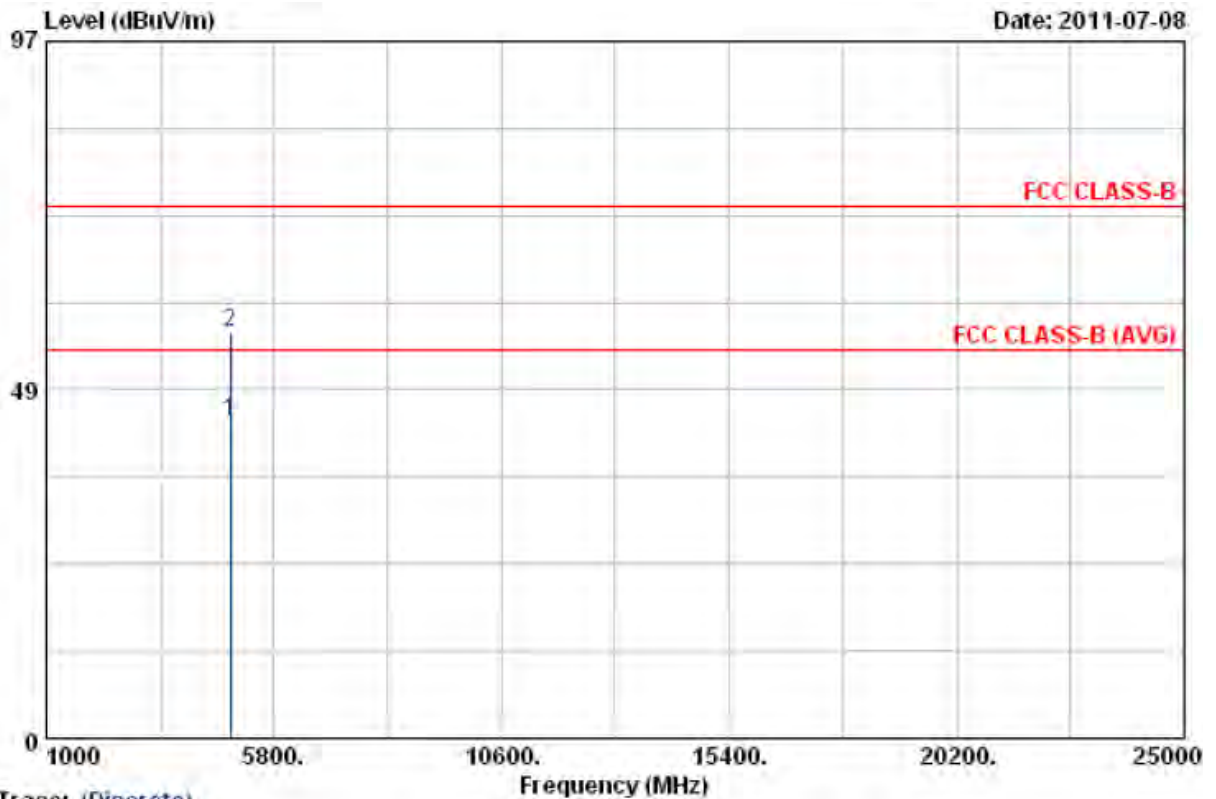

Trace: (Discrete)

Item	Freq	Read Value	Factor	Result	Limit	Margin	Remark	Ant Pos	Tab Pos
	MHz	dBuV	dB/m	dBuV/m	dBuV/m	dB		cm	Deg
1	4882.03	34.87	9.06	43.93	54.00	-10.07	Average	119	240
2	4882.03	47.46	9.06	56.54	74.00	-17.46	Peak	119	240

Notes:

1. Result = Read Value + Factor
2. Factor = Antenna Factor + Cable Loss - Amplifier
3. The resolution bandwidth of test receiver/spectrum analyzer is 120KHz and video bandwidth is 300kHz for Peak detection and Quasi-peak detection at frequency below 1GHz.
4. The resolution bandwidth of test receiver/spectrum analyzer is 1MHz and video bandwidth is 3MHz for Peak detection at frequency above 1GHz.
5. The resolution bandwidth of test receiver/spectrum analyzer is 1MHz and video bandwidth is 10Hz for Average detection at frequency above 1GHz.
6. The other emissions is too low to be measured.
7. The data is worse case.



Power	: AC 120V	Pol/Phase	: HORIZONTAL
Test Mode	: Transmit / Receive	Temperature	: 25 °C
Operation Channel	: 39	Humidity	: 60 %
Modulation Type	: GFSK	Atmospheric Pressure	: 1020 hPa
Memo	: Adapter: CWT \ KPC-010B	Rate	: 1 Mbps

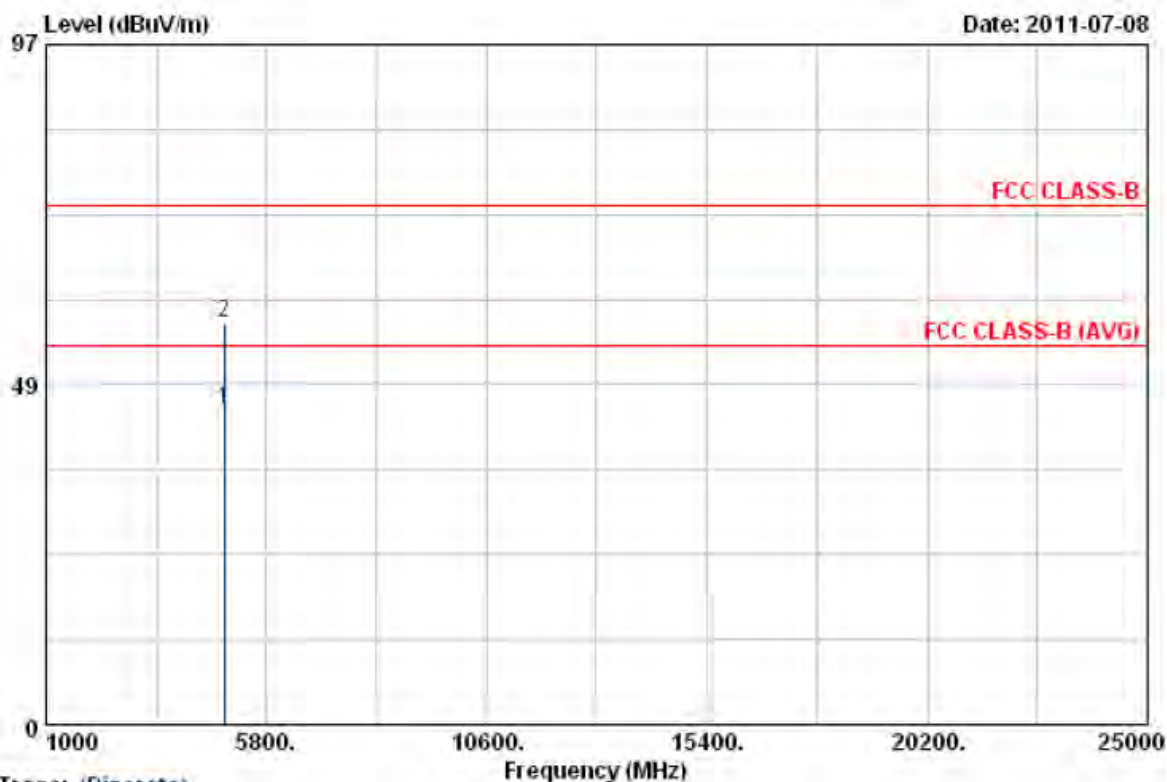

Trace: (Discrete)

Item	Freq	Read Value	Factor	Result	Limit	Margin	Remark	Ant Pos	Tab Pos
	MHz	dBuV	dB/m	dBuV/m	dBuV/m	dB		cm	Deg
1	4882.08	35.84	9.06	44.90	54.00	-9.10	Average	150	250
2	4882.08	48.16	9.06	57.24	74.00	-16.76	Peak	150	250

Notes:

1. Result = Read Value + Factor
2. Factor = Antenna Factor + Cable Loss - Amplifier
3. The resolution bandwidth of test receiver/spectrum analyzer is 120KHz and video bandwidth is 300kHz for Peak detection and Quasi-peak detection at frequency below 1GHz.
4. The resolution bandwidth of test receiver/spectrum analyzer is 1MHz and video bandwidth is 3MHz for Peak detection at frequency above 1GHz.
5. The resolution bandwidth of test receiver/spectrum analyzer is 1MHz and video bandwidth is 10Hz for Average detection at frequency above 1GHz.
6. The other emissions is too low to be measured.
7. The data is worse case.



Power	: AC 120V	Pol/Phase	: VERTICAL
Test Mode	: Transmit / Receive	Temperature	: 25 °C
Operation Channel	: 78	Humidity	: 60 %
Modulation Type	: GFSK	Atmospheric Pressure	: 1020 hPa
Memo	: Adapter: CWT \ KPC-010B	Rate	: 1 Mbps

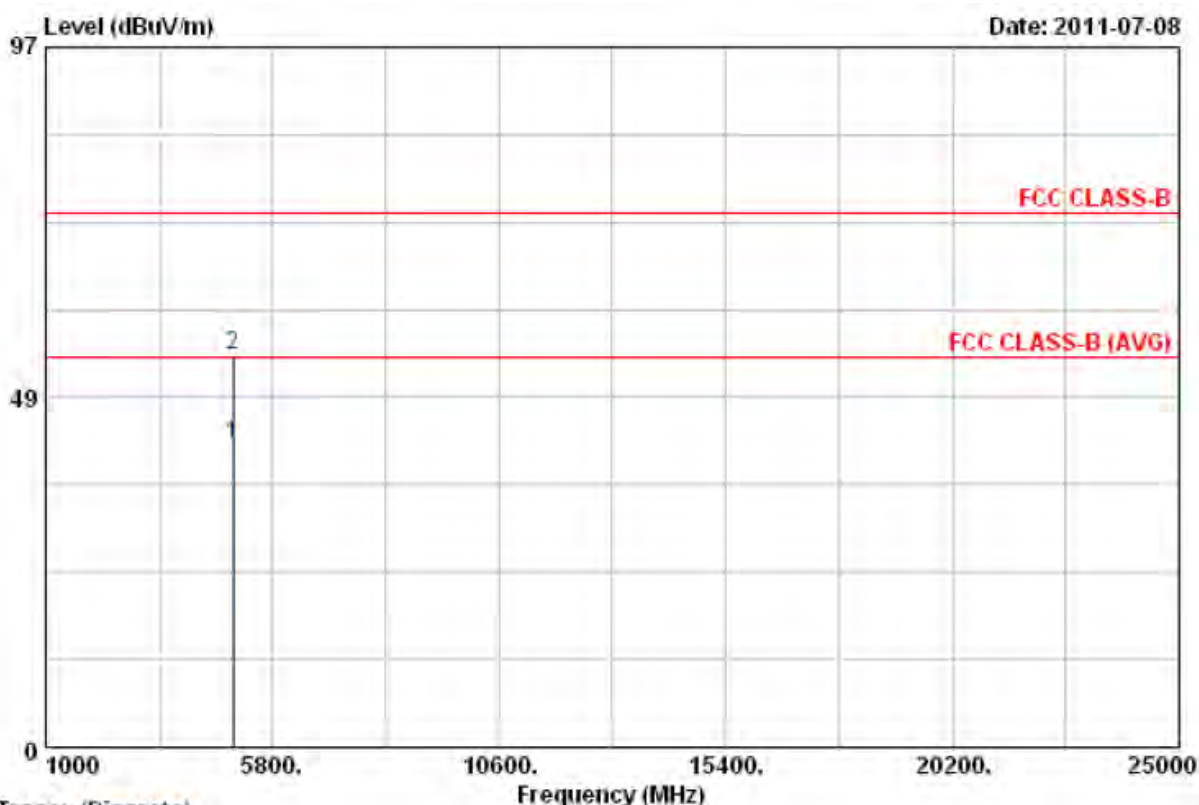

Trace: (Discrete)

Item	Freq	Read Value	Factor	Result	Limit	Margin	Remark	Ant Pos	Tab Pos
	MHz	dBuV	dB/m	dBuV/m	dBuV/m	dB		cm	Deg
1	4959.93	32.57	9.35	41.92	54.00	-12.08	Average	119	240
2	4959.93	44.96	9.35	54.31	74.00	-19.69	Peak	119	240

Notes:

1. Result = Read Value + Factor
2. Factor = Antenna Factor + Cable Loss - Amplifier
3. The resolution bandwidth of test receiver/spectrum analyzer is 120kHz and video bandwidth is 300kHz for Peak detection and Quasi-peak detection at frequency below 1GHz.
4. The resolution bandwidth of test receiver/spectrum analyzer is 1MHz and video bandwidth is 3MHz for Peak detection at frequency above 1GHz.
5. The resolution bandwidth of test receiver/spectrum analyzer is 1MHz and video bandwidth is 10Hz for Average detection at frequency above 1GHz.
6. The other emissions is too low to be measured.
7. The data is worse case.



Power	: AC 120V	Pol/Phase	: HORIZONTAL
Test Mode	: Transmit / Receive	Temperature	: 25 °C
Operation Channel	: 78	Humidity	: 60 %
Modulation Type	: GFSK	Atmospheric Pressure	: 1020 hPa
Memo	: Adapter: CWT \ KPC-010B	Rate	: 1 Mbps

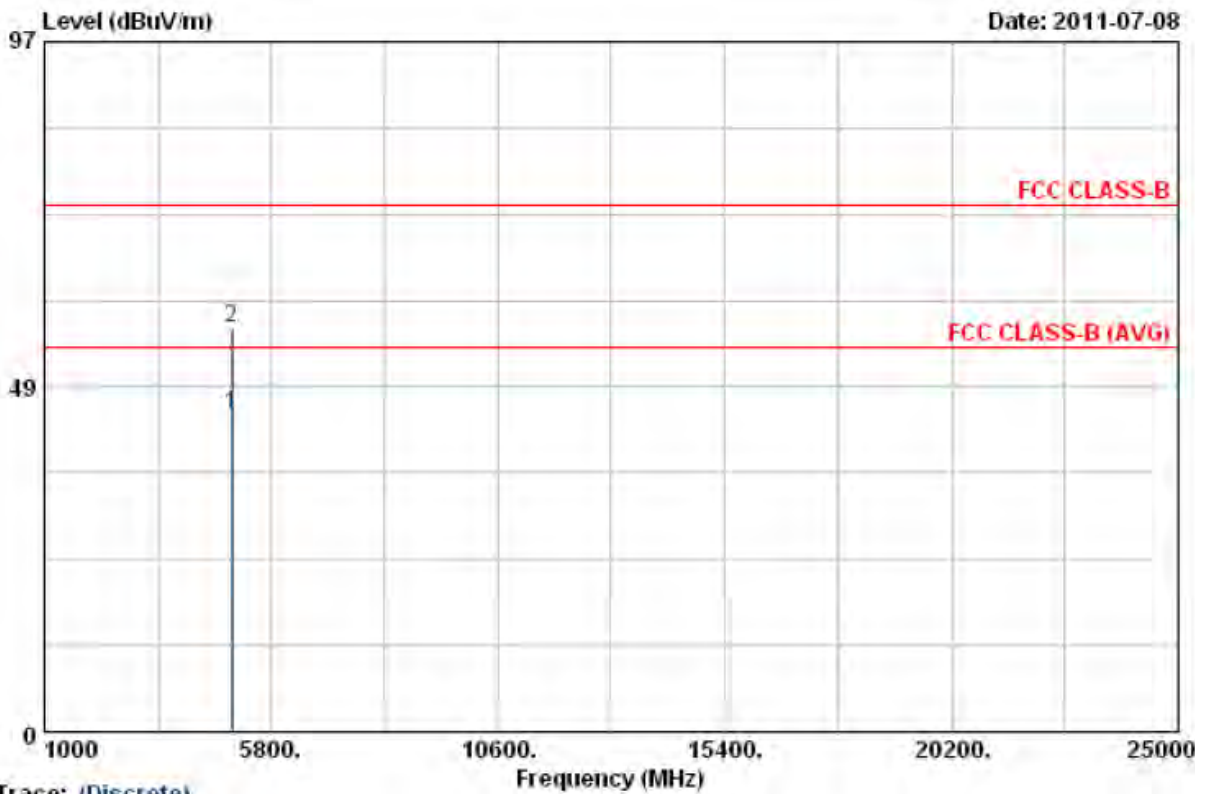

Trace: (Discrete)

Item	Freq	Read Value	Factor	Result	Limit	Margin	Remark	Ant Pos	Tab Pos
	MHz	dBuV	dB/m	dBuV/m	dBuV/m	dB		cm	Deg
1	4960.05	35.28	9.35	44.63	54.00	-9.37	Average	150	250
2	4960.05	47.37	9.35	56.72	74.00	-17.28	Peak	150	250

Notes:

1. Result = Read Value + Factor
2. Factor = Antenna Factor + Cable Loss - Amplifier
3. The resolution bandwidth of test receiver/spectrum analyzer is 120KHz and video bandwidth is 300kHz for Peak detection and Quasi-peak detection at frequency below 1GHz.
4. The resolution bandwidth of test receiver/spectrum analyzer is 1MHz and video bandwidth is 3MHz for Peak detection at frequency above 1GHz.
5. The resolution bandwidth of test receiver/spectrum analyzer is 1MHz and video bandwidth is 10Hz for Average detection at frequency above 1GHz.
6. The other emissions is too low to be measured.
7. The data is worse case.



Power	: AC 120V	Pol/Phase	: VERTICAL
Test Mode	: Transmit / Receive	Temperature	: 23 °C
Operation Channel	: 0	Humidity	: 65 %
Modulation Type	: $\pi/4$ -DQPSK	Atmospheric Pressure	: 1020 hPa
Memo	: Adapter: CWT \ KPC-010B	Rate	: 2 Mbps

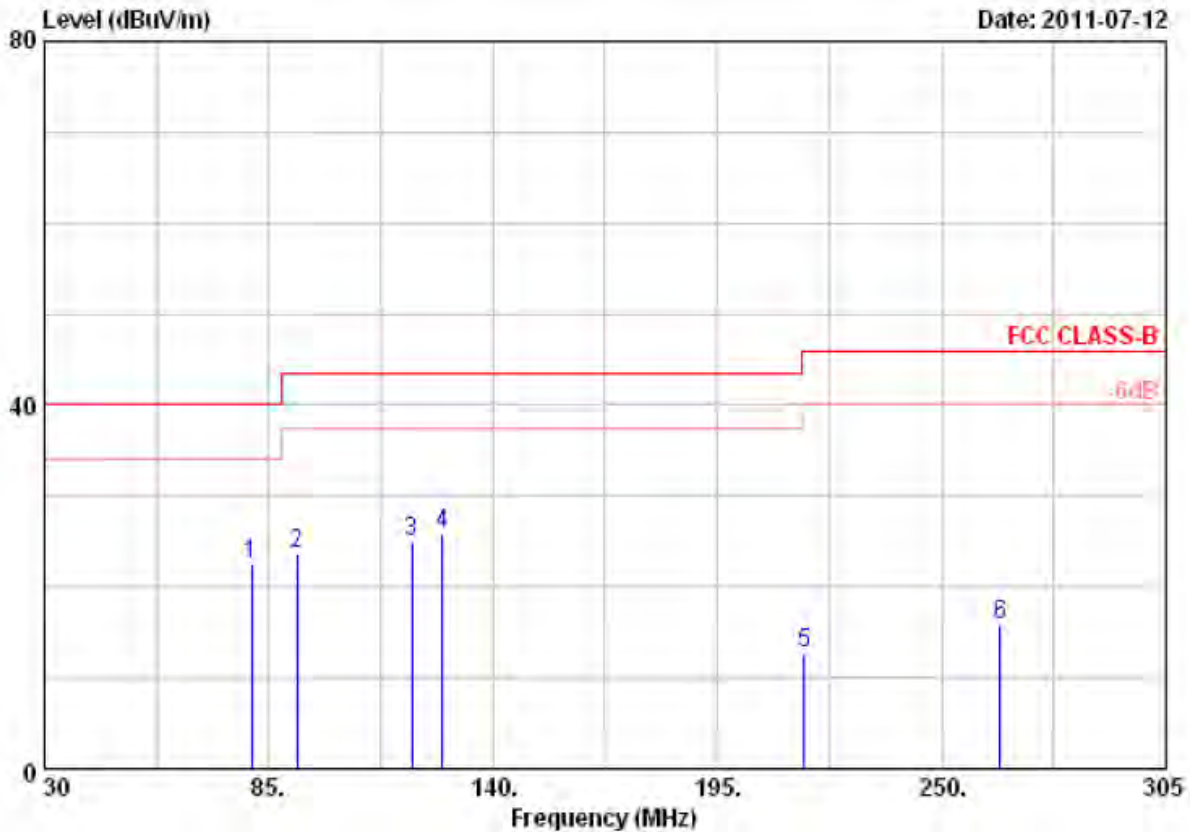

Item	Freq	Read Value	Factor	Result	Limit	Margin	Remark	Ant Pos	Tab Pos
	MHz	dBuV	dB/m	dBuV/m	dBuV/m	dB		cm	Deg
1	80.88	36.54	-13.95	22.59	40.00	-17.41	Peak	100	360
2	91.88	35.55	-11.89	23.66	43.50	-19.84	Peak	100	360
3	120.20	34.65	-9.73	24.92	43.50	-18.58	Peak	100	360
4	127.63	33.36	-7.52	25.84	43.50	-17.66	Peak	100	360
5	216.45	29.27	-16.57	12.70	46.00	-33.30	Peak	100	360
6	264.30	29.46	-13.74	15.72	46.00	-30.28	Peak	100	360

- Remarks:
1. Result = Read Value + Factor
 2. Factor = Antenna Factor + Cable Loss - Amplifier
 3. According to technical experiences, all spurious emission of BT mode at channel 0, 39, 78 are almost the same below 1GHz, so that the channel 0 was chosen as representative in final test.
 4. The data is worst case.



Power	: AC 120V	Pol/Phase	: VERTICAL
Test Mode	: Transmit / Receive	Temperature	: 23 °C
Operation Channel	: 0	Humidity	: 65 %
Modulation Type	: $\pi/4$ -DQPSK	Atmospheric Pressure	: 1020 hPa
Memo	: Adapter: CWT \ KPC-010B	Rate	: 2 Mbps

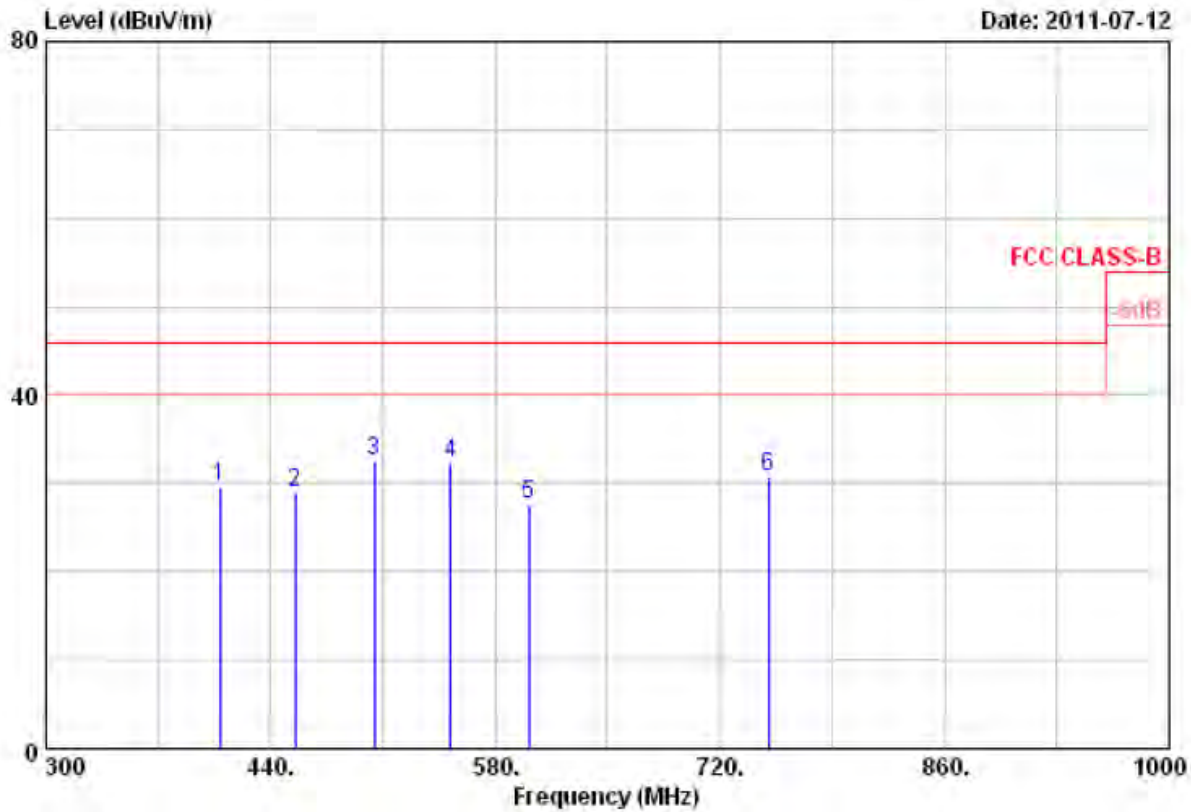

Item	Freq	Read Value	Factor	Result	Limit	Margin	Remark	Ant Pos	Tab Pos
	MHz	dBuV	dB/m	dBuV/m	dBuV/m	dB		cm	Deg
1	408.50	39.82	-10.09	29.73	46.00	-16.27	Peak	100	0
2	455.40	37.66	-8.59	29.07	46.00	-16.93	Peak	100	0
3	504.40	40.98	-8.46	32.52	46.00	-13.48	Peak	100	0
4	552.00	40.65	-8.38	32.27	46.00	-13.73	Peak	100	0
5	601.00	35.66	-8.02	27.64	46.00	-18.36	Peak	100	0
6	750.10	25.51	5.32	30.83	46.00	-15.17	Peak	100	0

- Remarks:
1. Result = Read Value + Factor
 2. Factor = Antenna Factor + Cable Loss - Amplifier
 3. According to technical experiences, all spurious emission of BT mode at channel 0,39,78 are almost the same below 1GHz, so that the channel 0 was chosen as representative in final test.
 4. The data is worst case.



Power	: AC 120V	Pol/Phase	: HORIZONTAL
Test Mode	: Transmit / Receive	Temperature	: 23 °C
Operation Channel	: 0	Humidity	: 65 %
Modulation Type	: $\pi/4$ -DQPSK	Atmospheric Pressure	: 1020 hPa
Memo	: Adapter: CWT \ KPC-010B	Rate	: 2 Mbps

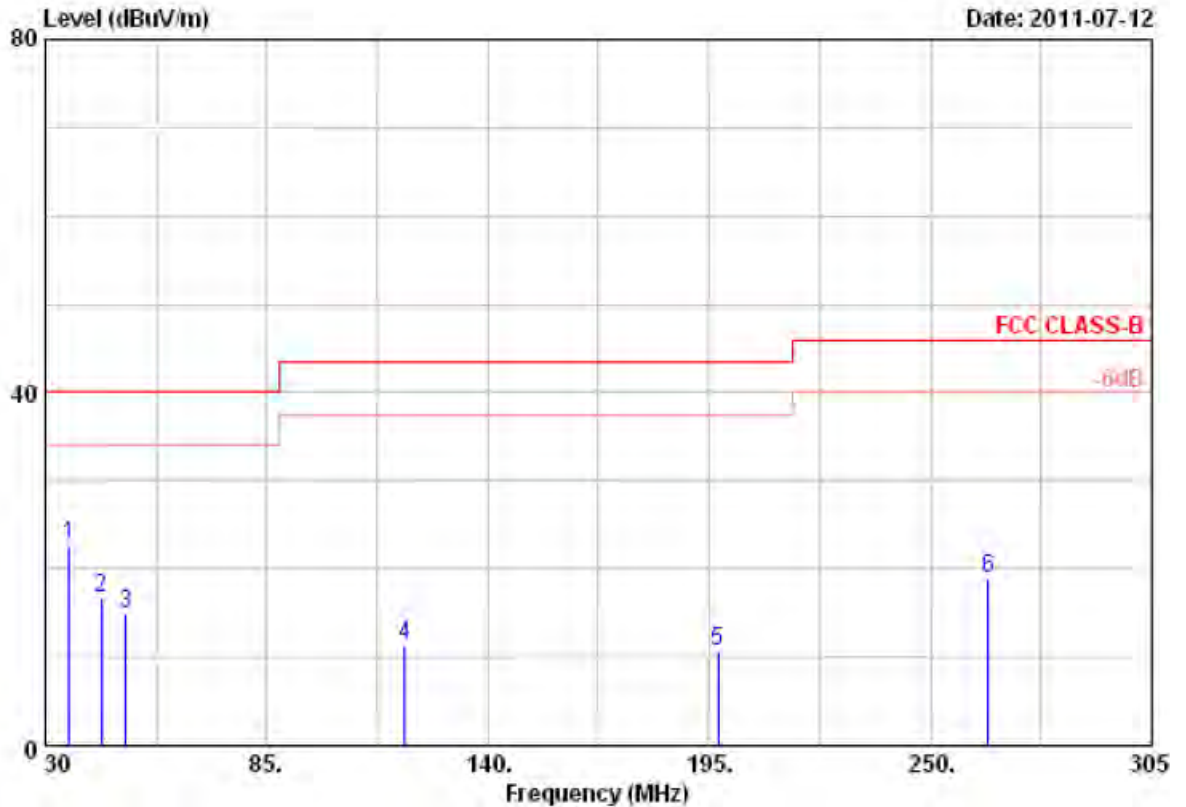

Item	Freq	Read Value	Factor	Result	Limit	Margin	Remark	Ant Pos	Tab Pos
	MHz	dBuV	dB/m	dBuV/m	dBuV/m	dB		cm	Deg
1	36.05	30.45	-7.76	22.69	40.00	-17.31	Peak	100	360
2	44.03	30.62	-13.89	16.73	40.00	-23.27	Peak	100	360
3	50.08	28.85	-13.84	15.01	40.00	-24.99	Peak	100	360
4	119.38	28.18	-16.79	11.39	43.50	-32.11	Peak	100	360
5	197.20	27.64	-16.91	10.73	43.50	-32.77	Peak	100	360
6	264.30	34.16	-15.13	19.03	46.00	-26.97	Peak	100	360

Remarks: 1. Result = Read Value + Factor
 2. Factor = Antenna Factor + Cable Loss - Amplifier
 3. According to technical experiences, all spurious emission of BT mode at channel 0,39,78 are almost the same below 1GHz, so that the channel 0 was chosen as representative in final test.
 4. The data is worst case.



Power	: AC 120V	Pol/Phase	: HORIZONTAL
Test Mode	: Transmit / Receive	Temperature	: 23 °C
Operation Channel	: 0	Humidity	: 65 %
Modulation Type	: $\pi/4$ -DQPSK	Atmospheric Pressure	: 1020 hPa
Memo	: Adapter: CWT \ KPC-010B	Rate	: 2 Mbps

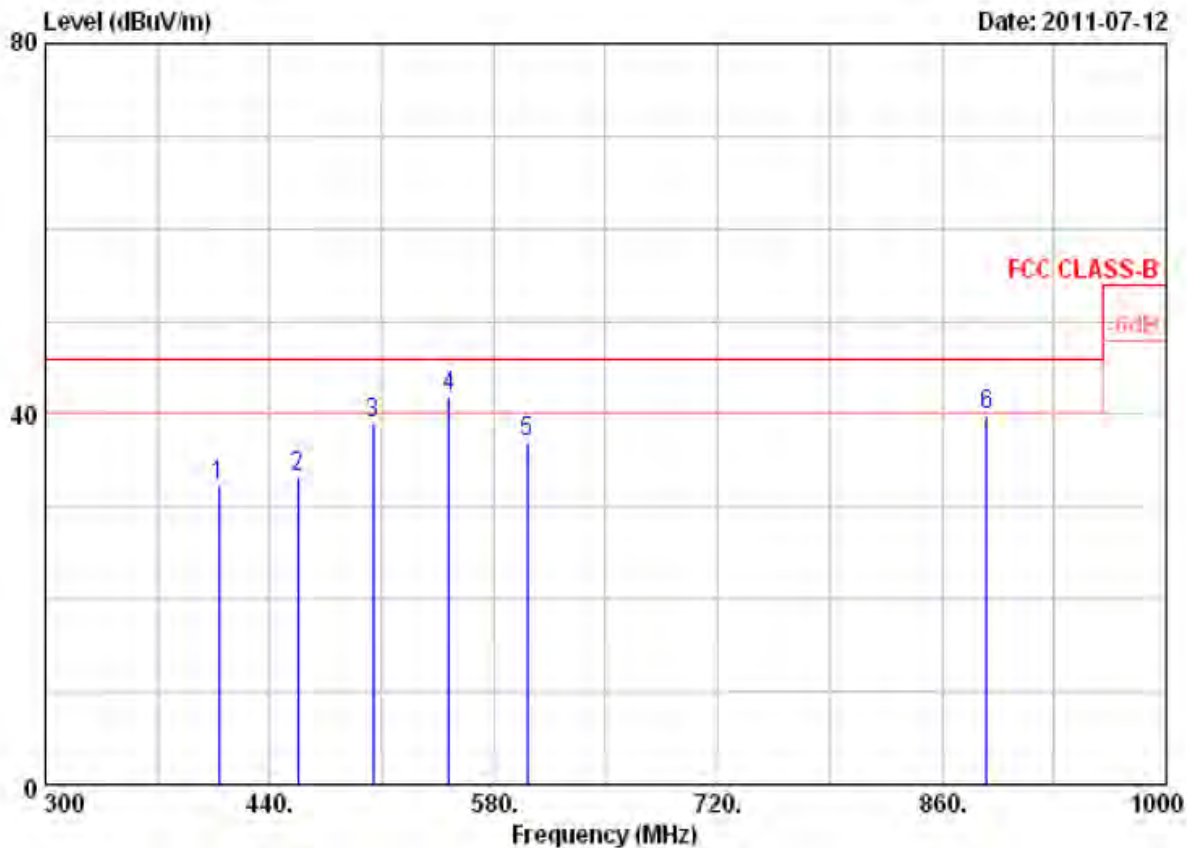

Item	Freq MHz	Read Value dBuV	Factor dB/m	Result dBuV/m	Limit dBuV/m	Margin dB	Remark	Ant Pos cm	Tab Pos Deg
1	408.50	42.63	-10.33	32.30	46.00	-13.70	Peak	100	0
2	457.50	41.38	-8.27	33.11	46.00	-12.89	Peak	100	0
3	504.40	43.47	-4.54	38.93	46.00	-7.07	Peak	100	0
4	552.00	42.64	-0.76	41.88	46.00	-4.12	QP	100	0
5	601.00	36.66	0.42	37.08	46.00	-8.92	Peak	100	0
6	888.00	29.64	10.34	39.98	46.00	-6.02	Peak	100	0

- Remarks:
1. Result = Read Value + Factor
 2. Factor = Antenna Factor + Cable Loss - Amplifier
 3. According to technical experiences, all spurious emission of BT mode at channel 0,39,78 are almost the same below 1GHz, so that the channel 0 was chosen as representative in final test.
 4. The data is worst case.



Power	: AC 120V	Pol/Phase	: VERTICAL
Test Mode	: Transmit / Receive	Temperature	: 25 °C
Operation Channel	: 0	Humidity	: 60 %
Modulation Type	: $\pi/4$ -DQPSK	Atmospheric Pressure	: 1020 hPa
Memo	: Adapter: CWT \ KPC-010B	Rate	: 2 Mbps

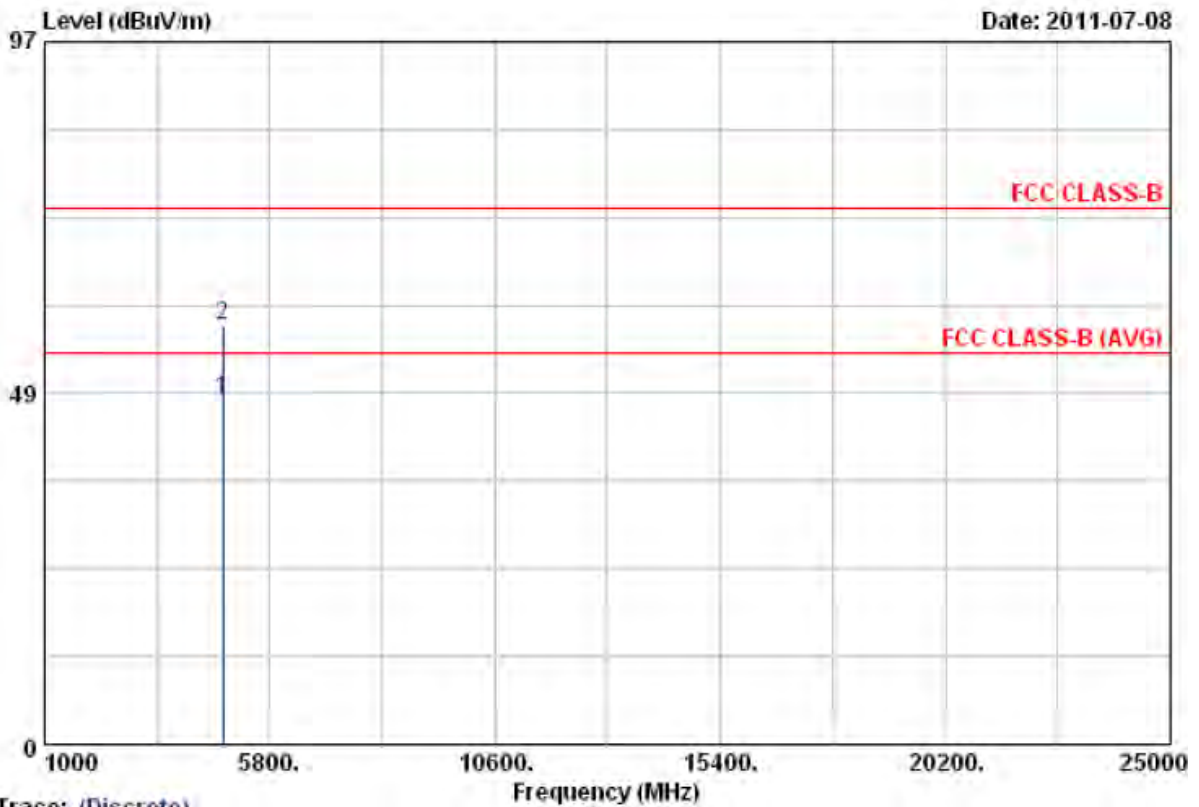

Trace: (Discrete)

Item	Freq	Read Value	Factor	Result	Limit	Margin	Remark	Ant Pos	Tab Pos
	MHz	dBuV	dB/m	dBuV/m	dBuV/m	dB		cm	Deg
1	4803.98	38.80	8.76	47.56	54.00	-6.44	Average	119	240
2	4803.98	48.96	8.76	57.72	74.00	-16.28	Peak	119	240

Notes:

1. Result = Read Value + Factor
2. Factor = Antenna Factor + Cable Loss - Amplifier
3. The resolution bandwidth of test receiver/spectrum analyzer is 120kHz and video bandwidth is 300kHz for Peak detection and Quasi-peak detection at frequency below 1GHz.
4. The resolution bandwidth of test receiver/spectrum analyzer is 1MHz and video bandwidth is 3MHz for Peak detection at frequency above 1GHz.
5. The resolution bandwidth of test receiver/spectrum analyzer is 1MHz and video bandwidth is 10Hz for Average detection at frequency above 1GHz.
6. The other emissions is too low to be measured.
7. The data is worse case.



Power	: AC 120V	Pol/Phase	: VERTICAL
Test Mode	: Transmit / Receive	Temperature	: 25 °C
Operation Channel	: 0	Humidity	: 60 %
Modulation Type	: $\pi/4$ -DQPSK	Atmospheric Pressure	: 1020 hPa
Memo	: Adapter: CWT \ KPC-010B	Rate	: 2 Mbps

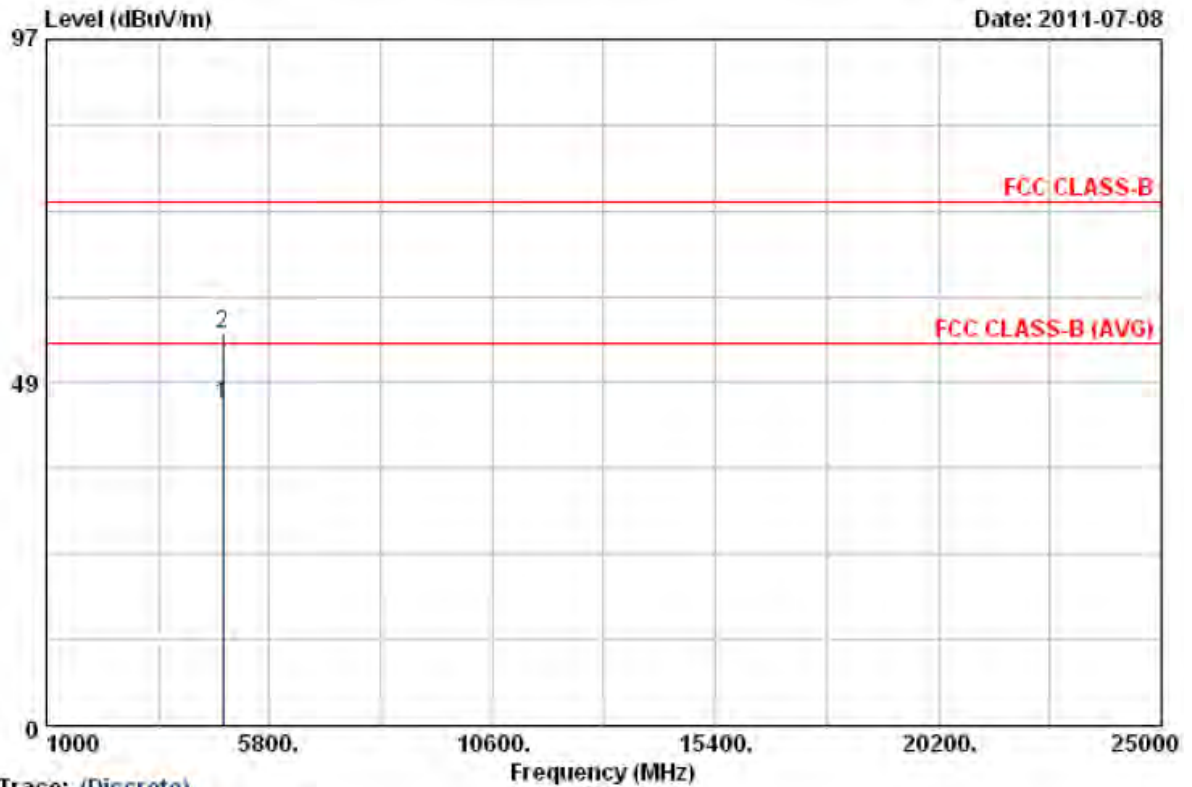

Trace: (Discrete)

Item	Freq	Read Value	Factor	Result	Limit	Margin	Remark	Ant Pos	Tab Pos
	MHz	dBuV	dB/m	dBuV/m	dBuV/m	dB		cm	Deg
1	4804.00	36.75	8.76	45.51	54.00	-8.49	Average	150	250
2	4804.00	46.61	8.76	55.37	74.00	-18.63	Peak	150	250

Notes:

1. Result = Read Value + Factor
2. Factor = Antenna Factor + Cable Loss - Amplifier
3. The resolution bandwidth of test receiver/spectrum analyzer is 120KHz and video bandwidth is 300kHz for Peak detection and Quasi-peak detection at frequency below 1GHz.
4. The resolution bandwidth of test receiver/spectrum analyzer is 1MHz and video bandwidth is 3MHz for Peak detection at frequency above 1GHz.
5. The resolution bandwidth of test receiver/spectrum analyzer is 1MHz and video bandwidth is 10Hz for Average detection at frequency above 1GHz.
6. The other emissions is too low to be measured.
7. The data is worse case.



Power	: AC 120V	Pol/Phase	: VERTICAL
Test Mode	: Transmit / Receive	Temperature	: 25 °C
Operation Channel	: 39	Humidity	: 60 %
Modulation Type	: $\pi/4$ -DQPSK	Atmospheric Pressure	: 1020 hPa
Memo	: Adapter: CWT \ KPC-010B	Rate	: 2 Mbps

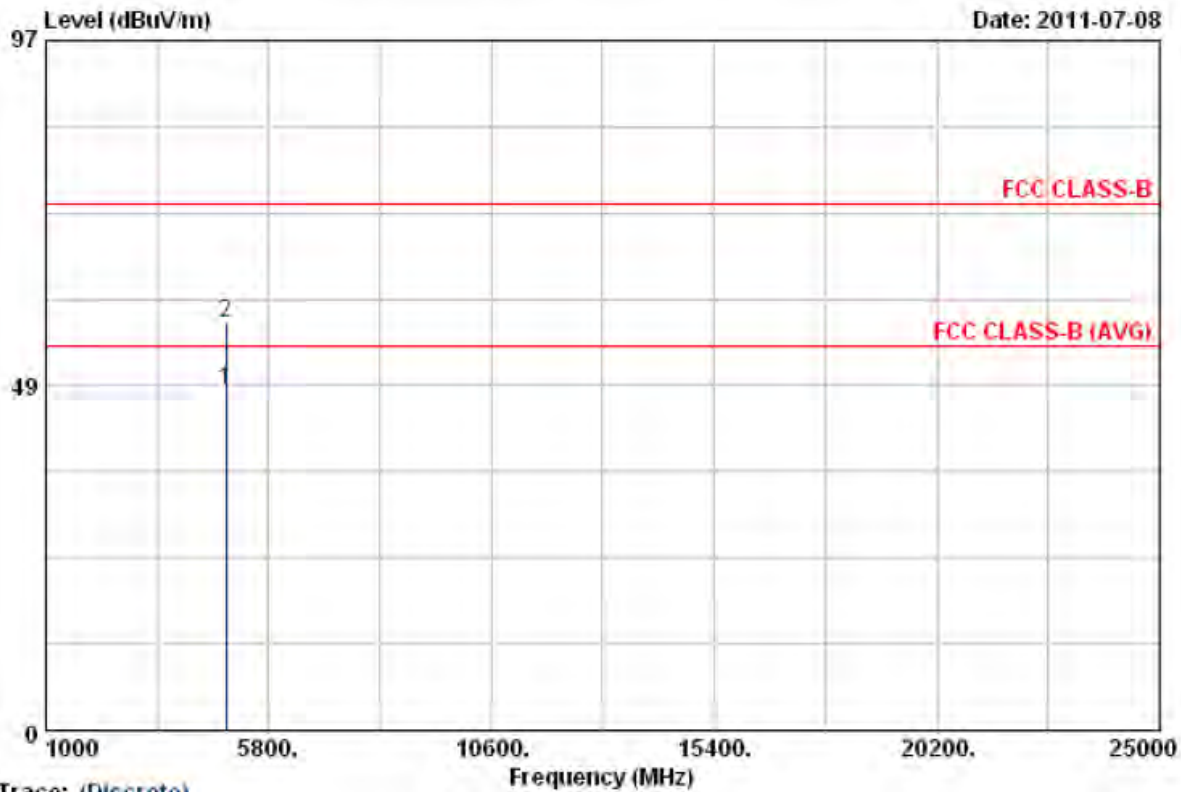

Trace: (Discrete)

Item	Freq	Read Value	Factor	Result	Limit	Margin	Remark	Ant Pos	Tab Pos
	MHz	dBuV	dB/m	dBuV/m	dBuV/m	dB		cm	Deg
1	4882.00	38.77	9.06	47.83	54.00	-6.17	Average	119	240
2	4882.00	48.30	9.06	57.36	74.00	-16.64	Peak	119	240

Notes:

1. Result = Read Value + Factor
2. Factor = Antenna Factor + Cable Loss - Amplifier
3. The resolution bandwidth of test receiver/spectrum analyzer is 120KHz and video bandwidth is 300kHz for Peak detection and Quasi-peak detection at frequency below 1GHz.
4. The resolution bandwidth of test receiver/spectrum analyzer is 1MHz and video bandwidth is 3MHz for Peak detection at frequency above 1GHz.
5. The resolution bandwidth of test receiver/spectrum analyzer is 1MHz and video bandwidth is 10Hz for Average detection at frequency above 1GHz.
6. The other emissions is too low to be measured.
7. The data is worse case.



Power	: AC 120V	Pol/Phase	: HORIZONTAL
Test Mode	: Transmit / Receive	Temperature	: 25 °C
Operation Channel	: 39	Humidity	: 60 %
Modulation Type	: $\pi/4$ -DQPSK	Atmospheric Pressure	: 1020 hPa
Memo	: Adapter: CWT \ KPC-010B	Rate	: 2 Mbps

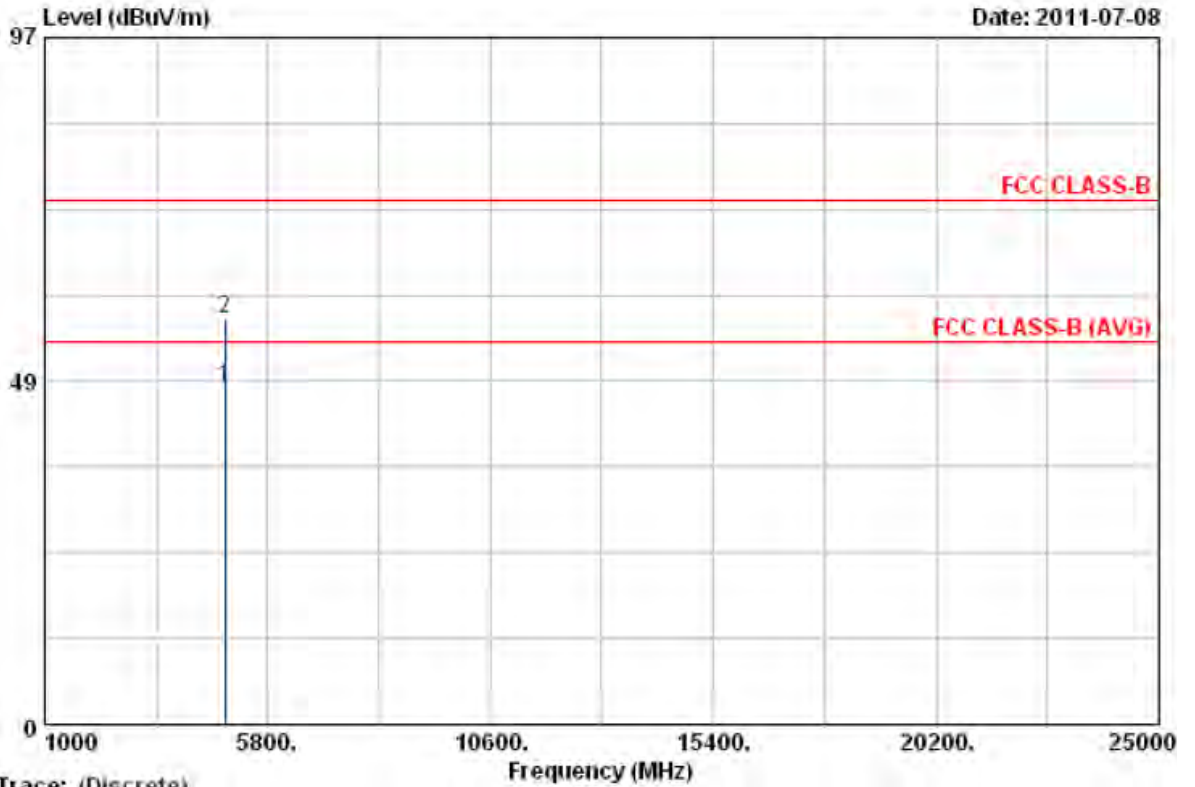

Trace: (Discrete)

Item	Freq	Read Value	Factor	Result	Limit	Margin	Remark	Ant Pos	Tab Pos
	MHz	dBuV	dB/m	dBuV/m	dBuV/m	dB		cm	Deg
1	4882.03	38.62	9.06	47.68	54.00	-6.32	Average	150	250
2	4882.03	48.12	9.06	57.18	74.00	-16.82	Peak	150	250

Notes:

1. Result = Read Value + Factor
2. Factor = Antenna Factor + Cable Loss - Amplifier
3. The resolution bandwidth of test receiver/spectrum analyzer is 120KHz and video bandwidth is 300kHz for Peak detection and Quasi-peak detection at frequency below 1GHz.
4. The resolution bandwidth of test receiver/spectrum analyzer is 1MHz and video bandwidth is 3MHz for Peak detection at frequency above 1GHz.
5. The resolution bandwidth of test receiver/spectrum analyzer is 1MHz and video bandwidth is 10Hz for Average detection at frequency above 1GHz.
6. The other emissions is too low to be measured.
7. The data is worse case.



Power	: AC 120V	Pol/Phase	: VERTICAL
Test Mode	: Transmit / Receive	Temperature	: 25 °C
Operation Channel	: 78	Humidity	: 60 %
Modulation Type	: $\pi/4$ -DQPSK	Atmospheric Pressure	: 1020 hPa
Memo	: Adapter: CWT \ KPC-010B	Rate	: 2 Mbps

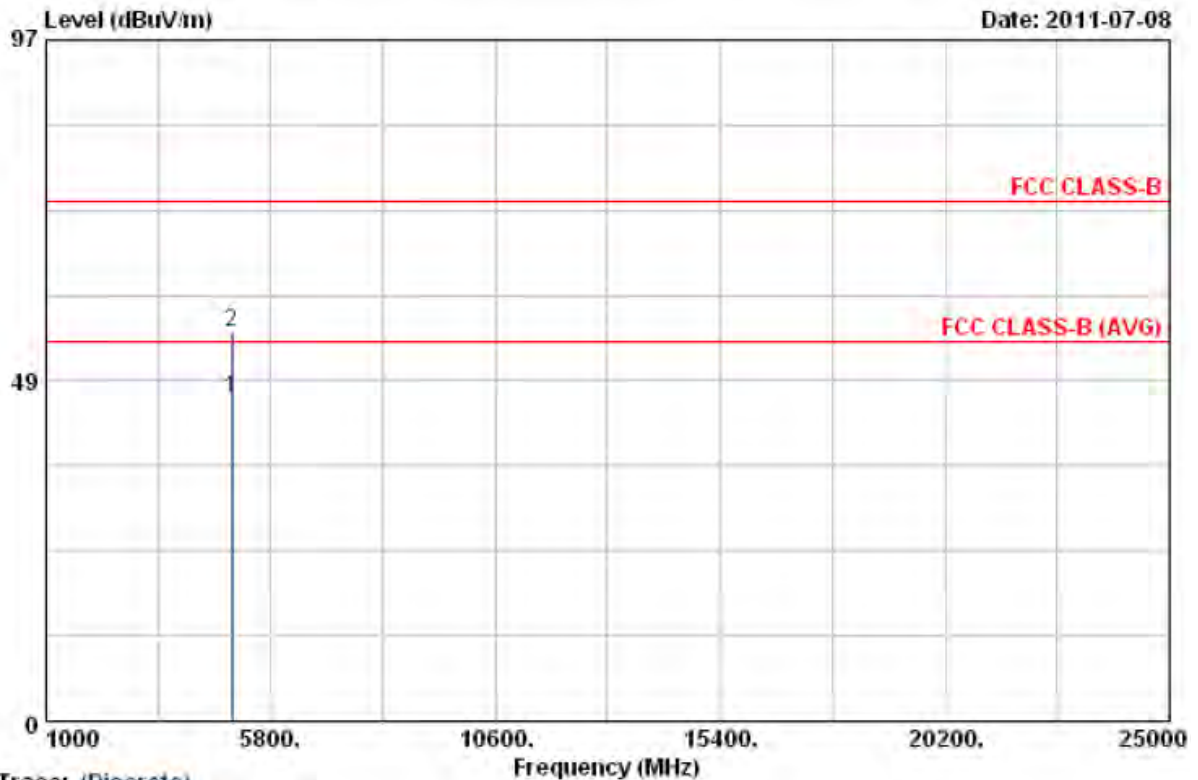

Trace: (Discrete)

Item	Freq	Read Value	Factor	Result	Limit	Margin	Remark	Ant Pos	Tab Pos
	MHz	dBuV	dB/m	dBuV/m	dBuV/m	dB		cm	Deg
1	4960.00	36.58	9.35	45.93	54.00	-8.07	Average	119	240
2	4960.00	46.05	9.35	55.40	74.00	-18.60	Peak	119	240

Notes:

1. Result = Read Value + Factor
2. Factor = Antenna Factor + Cable Loss - Amplifier
3. The resolution bandwidth of test receiver/spectrum analyzer is 120KHz and video bandwidth is 300kHz for Peak detection and Quasi-peak detection at frequency below 1GHz.
4. The resolution bandwidth of test receiver/spectrum analyzer is 1MHz and video bandwidth is 3MHz for Peak detection at frequency above 1GHz.
5. The resolution bandwidth of test receiver/spectrum analyzer is 1MHz and video bandwidth is 10Hz for Average detection at frequency above 1GHz.
6. The other emissions is too low to be measured.
7. The data is worse case.



Power	: AC 120V	Pol/Phase	: HORIZONTAL
Test Mode	: Transmit / Receive	Temperature	: 25 °C
Operation Channel	: 78	Humidity	: 60 %
Modulation Type	: $\pi/4$ -DQPSK	Atmospheric Pressure	: 1020 hPa
Memo	: Adapter: CWT \ KPC-010B	Rate	: 2 Mbps

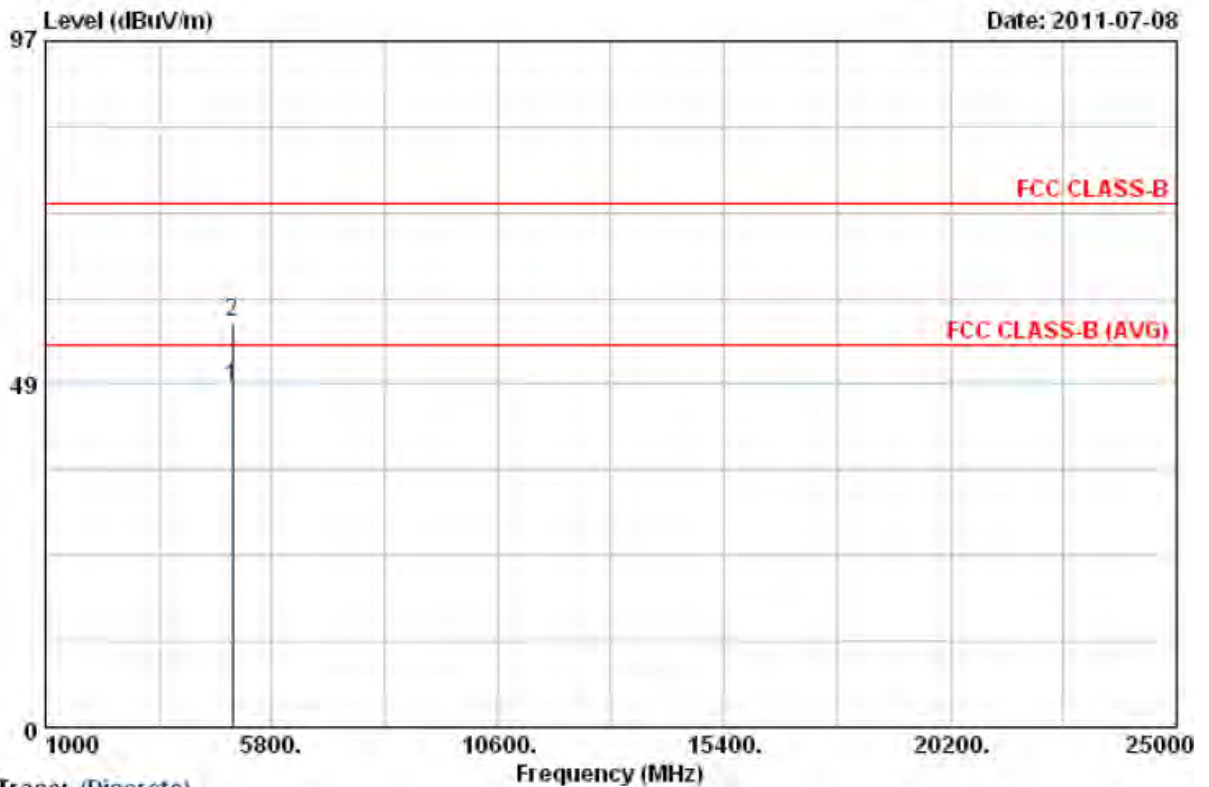

Trace: (Discrete)

Item	Freq	Read Value	Factor	Result	Limit	Margin	Remark	Ant Pos	Tab Pos
	MHz	dBuV	dB/m	dBuV/m	dBuV/m	dB		cm	Deg
1	4959.98	38.64	9.35	47.99	54.00	-6.01	Average	150	250
2	4959.98	48.00	9.35	57.35	74.00	-16.65	Peak	150	250

Notes:

1. Result = Read Value + Factor
2. Factor = Antenna Factor + Cable Loss - Amplifier
3. The resolution bandwidth of test receiver/spectrum analyzer is 120KHz and video bandwidth is 300kHz for Peak detection and Quasi-peak detection at frequency below 1GHz.
4. The resolution bandwidth of test receiver/spectrum analyzer is 1MHz and video bandwidth is 3MHz for Peak detection at frequency above 1GHz.
5. The resolution bandwidth of test receiver/spectrum analyzer is 1MHz and video bandwidth is 10Hz for Average detection at frequency above 1GHz.
6. The other emissions is too low to be measured.
7. The data is worse case.



Power	: AC 120V	Pol/Phase	: VERTICAL
Test Mode	: Transmit / Receive	Temperature	: 23 °C
Operation Channel	: 0	Humidity	: 65 %
Modulation Type	: 8DPSK	Atmospheric Pressure	: 1020 hPa
Memo	: Adapter: CWT \ KPC-010B	Rate	: 3 Mbps

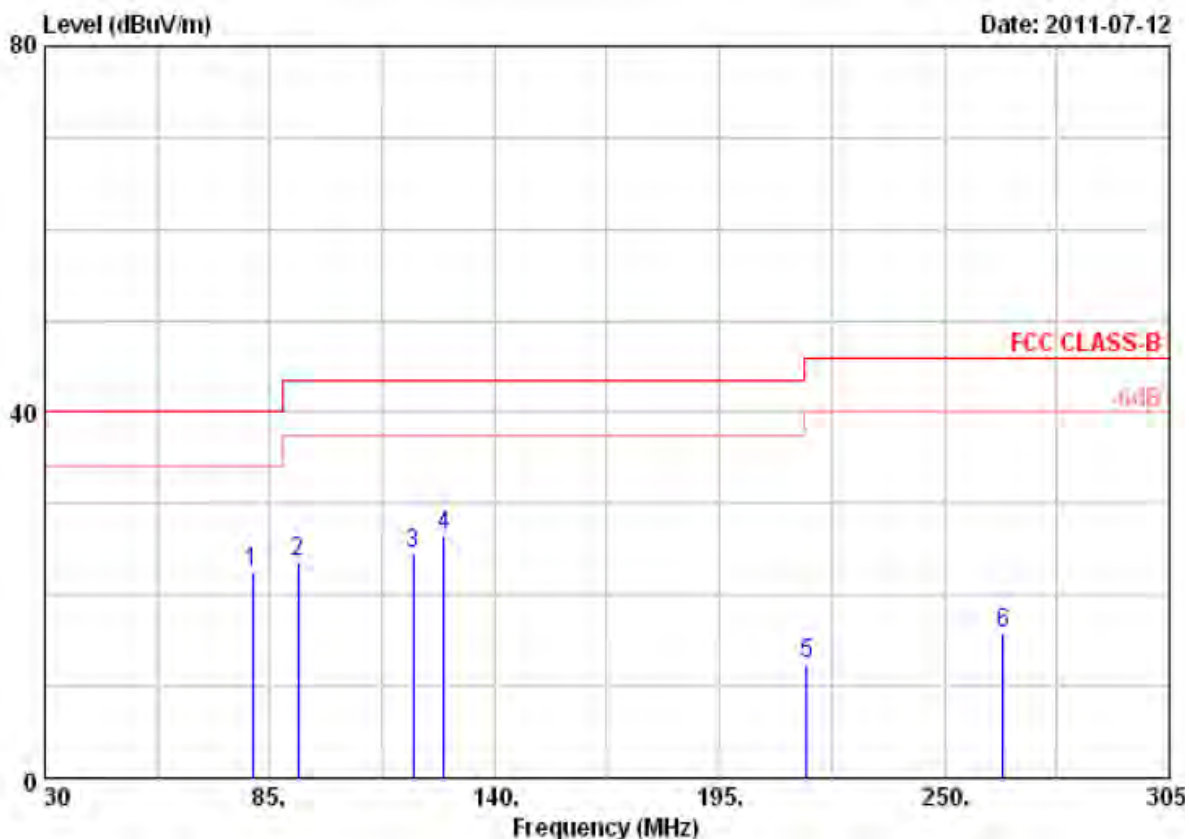

Item	Freq	Read Value	Factor	Result	Limit	Margin	Remark	Ant Pos	Tab Pos
	MHz	dBuV	dB/m	dBuV/m	dBuV/m	dB		cm	Deg
1	80.88	36.49	-13.95	22.54	40.00	-17.46	Peak	100	360
2	91.88	35.58	-11.89	23.69	43.50	-19.81	Peak	100	360
3	120.20	34.19	-9.73	24.46	43.50	-19.04	Peak	100	360
4	127.63	33.99	-7.52	26.47	43.50	-17.03	Peak	100	360
5	216.45	29.11	-16.57	12.54	46.00	-33.46	Peak	100	360
6	264.30	29.60	-13.74	15.86	46.00	-30.14	Peak	100	360

Remarks:

1. Result = Read Value + Factor
2. Factor = Antenna Factor + Cable Loss - Amplifier
3. According to technical experiences, all spurious emission of BT mode at channel 0,39,78 are almost the same below 1GHz, so that the channel 0 was chosen as representative in final test.
4. The data is worst case.



Power	: AC 120V	Pol/Phase	: VERTICAL
Test Mode	: Transmit / Receive	Temperature	: 23 °C
Operation Channel	: 0	Humidity	: 65 %
Modulation Type	: 8DPSK	Atmospheric Pressure	: 1020 hPa
Memo	: Adapter: CWT \ KPC-010B	Rate	: 3 Mbps

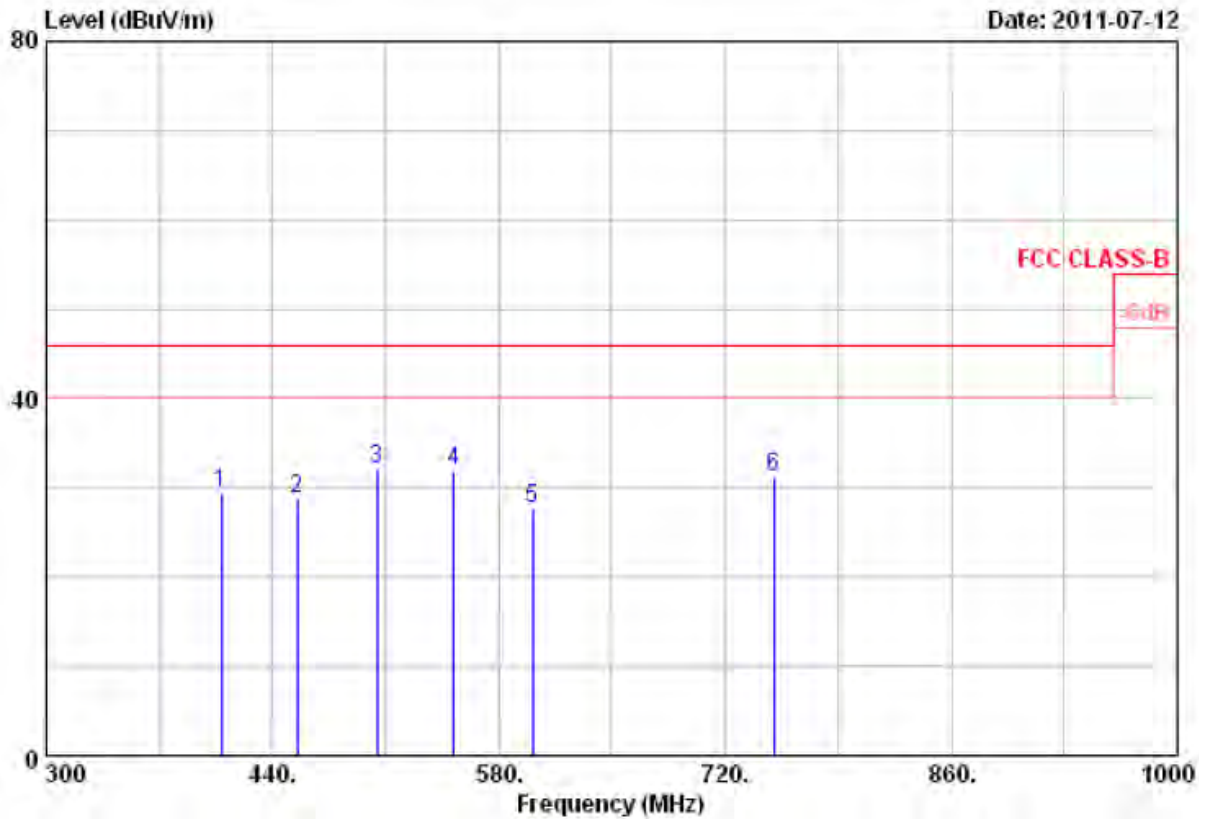

Item	Freq	Read Value	Factor	Result	Limit	Margin	Remark	Ant Pos	Tab Pos
	MHz	dBuV	dB/m	dBuV/m	dBuV/m	dB		cm	Deg
1	408.50	39.47	-10.09	29.38	46.00	-16.62	Peak	100	0
2	455.40	37.43	-8.59	28.84	46.00	-17.16	Peak	100	0
3	504.40	40.46	-8.46	32.00	46.00	-14.00	Peak	100	0
4	552.00	40.16	-8.38	31.78	46.00	-14.22	Peak	100	0
5	601.00	35.66	-8.02	27.64	46.00	-18.36	Peak	100	0
6	750.10	25.84	5.32	31.16	46.00	-14.84	Peak	100	0

- Remarks:
1. Result = Read Value + Factor
 2. Factor = Antenna Factor + Cable Loss - Amplifier
 3. According to technical experiences, all spurious emission of BT mode at channel 0,39,78 are almost the same below 1GHz, so that the channel 0 was chosen as representative in final test.
 4. The data is worst case.



Power	: AC 120V	Pol/Phase	: HORIZONTAL
Test Mode	: Transmit / Receive	Temperature	: 23 °C
Operation Channel	: 0	Humidity	: 65 %
Modulation Type	: 8DPSK	Atmospheric Pressure	: 1020 hPa
Memo	: Adapter: CWT \ KPC-010B	Rate	: 3 Mbps

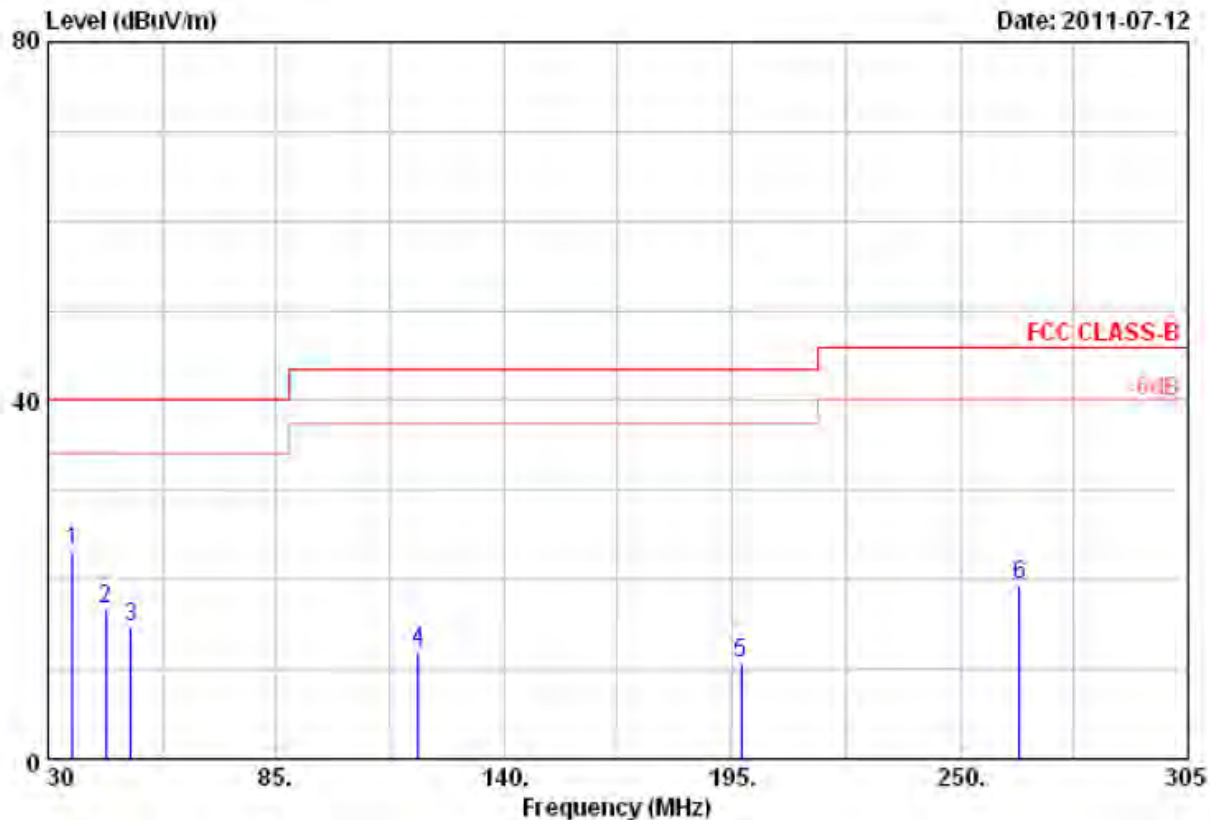

Item	Freq	Read Value	Factor	Result	Limit	Margin	Remark	Ant Pos	Tab Pos
	MHz	dBuV	dB/m	dBuV/m	dBuV/m	dB		cm	Deg
1	36.05	30.84	-7.76	23.08	40.00	-16.92	Peak	100	360
2	44.03	30.65	-13.89	16.76	40.00	-23.24	Peak	100	360
3	50.08	28.59	-13.84	14.75	40.00	-25.25	Peak	100	360
4	119.38	28.89	-16.79	12.10	43.50	-31.40	Peak	100	360
5	197.20	27.64	-16.91	10.73	43.50	-32.77	Peak	100	360
6	264.30	34.46	-15.13	19.33	46.00	-26.67	Peak	100	360

Remarks: 1. Result = Read Value + Factor
 2. Factor = Antenna Factor + Cable Loss - Amplifier
 3. According to technical experiences, all spurious emission of BT mode at channel 0,39,78 are almost the same below 1GHz, so that the channel 0 was chosen as representative in final test.
 4. The data is worst case.



Power	: AC 120V	Pol/Phase	: HORIZONTAL
Test Mode	: Transmit / Receive	Temperature	: 23 °C
Operation Channel	: 0	Humidity	: 65 %
Modulation Type	: 8DPSK	Atmospheric Pressure	: 1020 hPa
Memo	: Adapter: CWT \ KPC-010B	Rate	: 3 Mbps

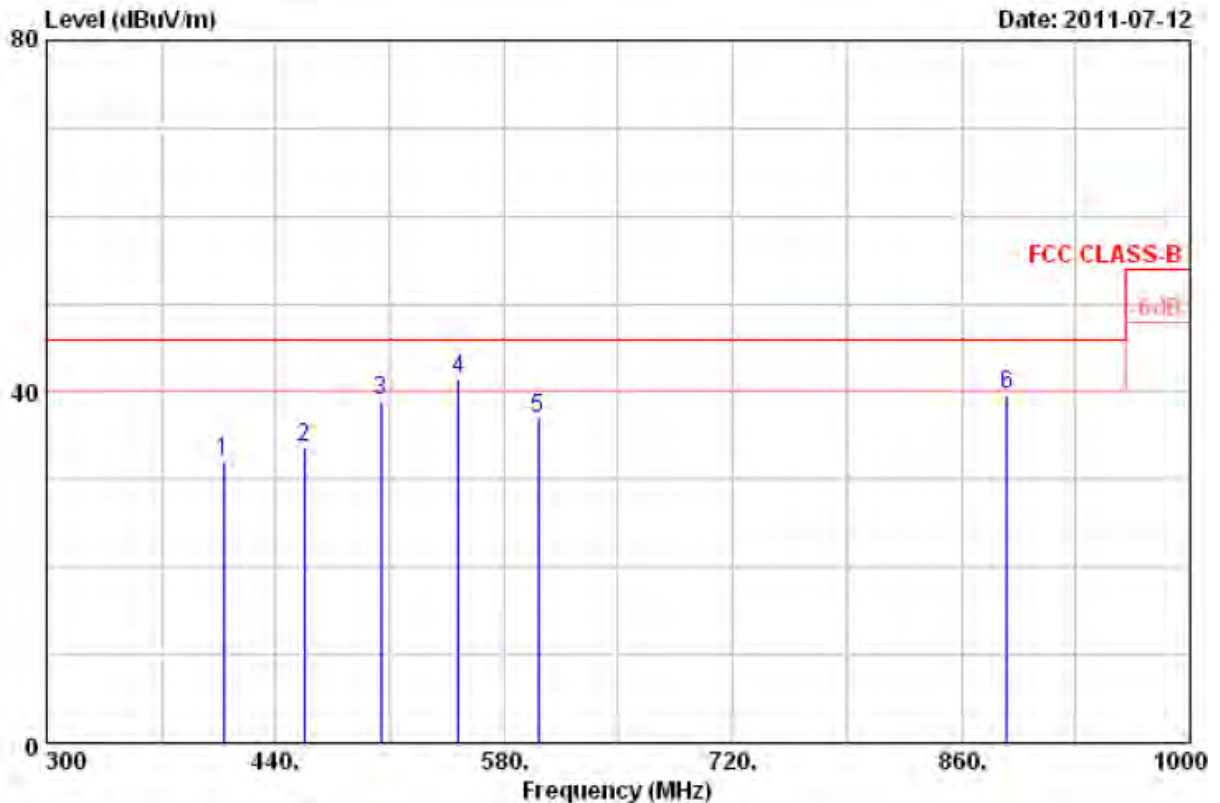

Item	Freq	Read Value	Factor	Result	Limit	Margin	Remark	Ant Pos	Tab Pos
	MHz	dBuV	dB/m	dBuV/m	dBuV/m	dB		cm	Deg
1	408.50	42.48	-10.33	32.15	46.00	-13.85	Peak	100	0
2	457.50	41.98	-8.27	33.71	46.00	-12.29	Peak	100	0
3	504.40	43.54	-4.54	39.00	46.00	-7.00	Peak	100	0
4	552.00	42.31	-0.76	41.55	46.00	-4.45	QP	100	0
5	601.00	36.52	0.42	36.94	46.00	-9.06	Peak	100	0
6	888.00	29.32	10.34	39.66	46.00	-6.34	Peak	100	0

- Remarks:
1. Result = Read Value + Factor
 2. Factor = Antenna Factor + Cable Loss - Amplifier
 3. According to technical experiences, all spurious emission of BT mode at channel 0,39,78 are almost the same below 1GHz, so that the channel 0 was chosen as representative in final test.
 4. The data is worst case.



Power	: AC 120V	Pol/Phase	: VERTICAL
Test Mode	: Transmit / Receive	Temperature	: 25 °C
Operation Channel	: 0	Humidity	: 60 %
Modulation Type	: 8DPSK	Atmospheric Pressure	: 1007 hPa
Memo	: Adapter: CWT \ KPC-010B	Rate	: 3 Mbps

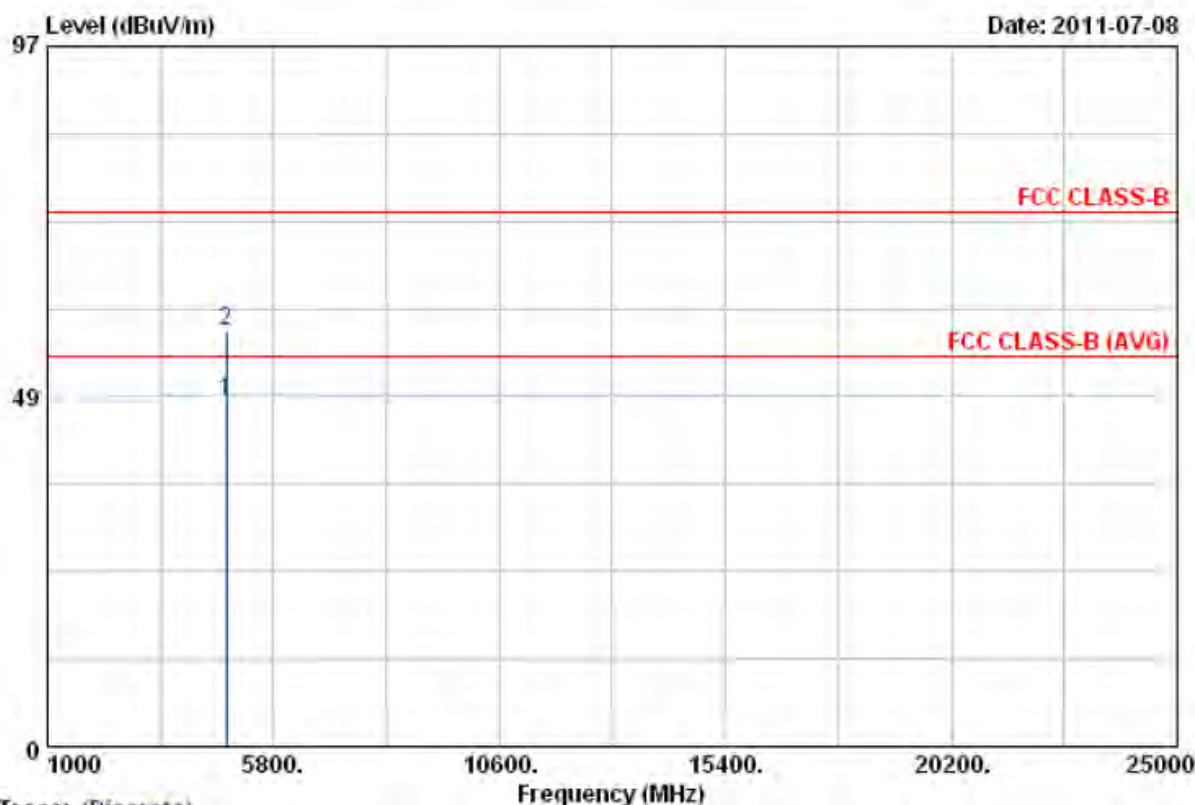

Trace: (Discrete)

Item	Freq	Read Value	Factor	Result	Limit	Margin	Remark	Ant Pos	Tab Pos
	MHz	dBuV	dB/m	dBuV/m	dBuV/m	dB		cm	Deg
1	4604.00	38.97	8.76	47.73	54.00	-6.27	Average	119	240
2	4604.00	48.68	8.76	57.44	74.00	-16.56	Peak	119	240

Notes:

1. Result = Read Value + Factor
2. Factor = Antenna Factor + Cable Loss - Amplifier
3. The resolution bandwidth of test receiver/spectrum analyzer is 120KHz and video bandwidth is 300kHz for Peak detection and Quasi-peak detection at frequency below 1GHz.
4. The resolution bandwidth of test receiver/spectrum analyzer is 1MHz and video bandwidth is 3MHz for Peak detection at frequency above 1GHz.
5. The resolution bandwidth of test receiver/spectrum analyzer is 1MHz and video bandwidth is 10Hz for Average detection at frequency above 1GHz.
6. The other emissions is too low to be measured.
7. The data is worse case.



Power	: AC 120V	Pol/Phase	: HORIZONTAL
Test Mode	: Transmit / Receive	Temperature	: 25 °C
Operation Channel	: 0	Humidity	: 60 %
Modulation Type	: 8DPSK	Atmospheric Pressure	: 1007 hPa
Memo	: Adapter: CWT \ KPC-010B	Rate	: 3 Mbps

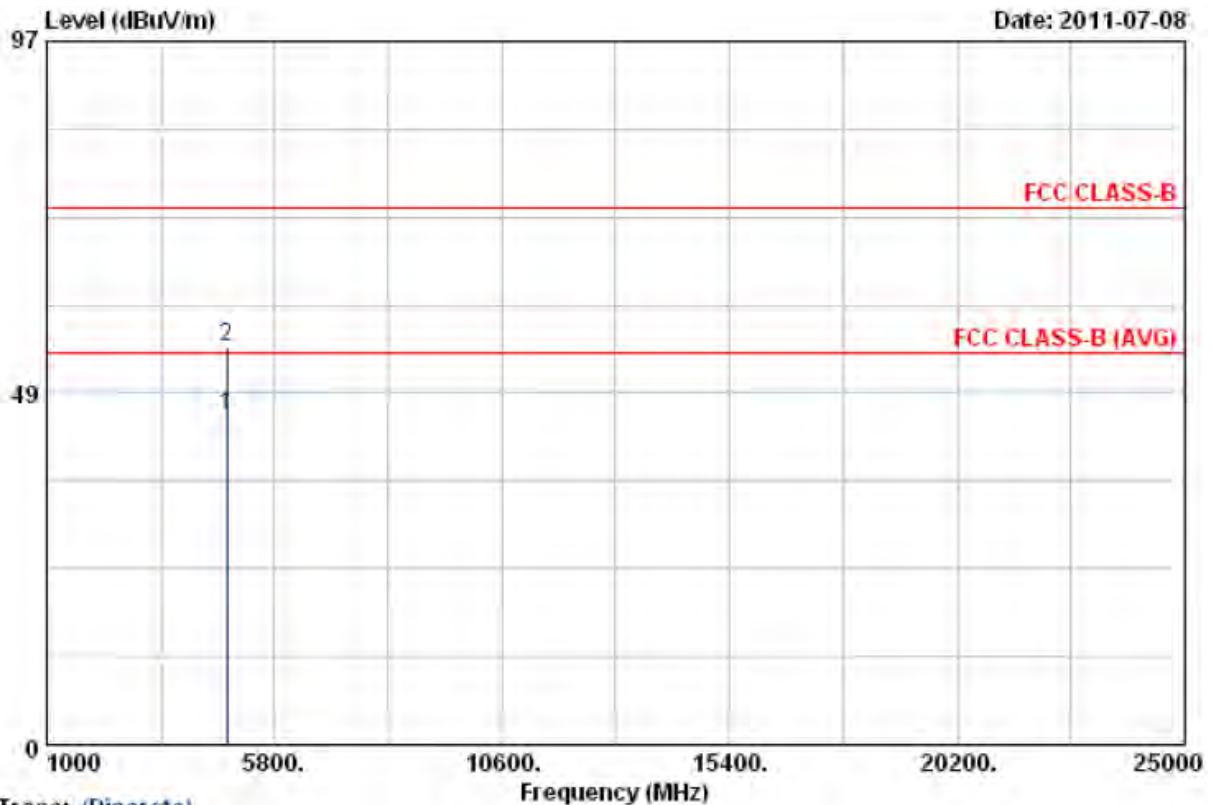

Trace: (Discrete)

Item	Freq	Read Value	Factor	Result	Limit	Margin	Remark	Ant Pos	Tab Pos
	MHz	dBuV	dB/m	dBuV/m	dBuV/m	dB		cm	Deg
1	4804.00	36.66	8.76	45.42	54.00	-8.58	Average	150	250
2	4804.00	46.10	8.76	54.86	74.00	-19.14	Peak	150	250

Notes:

1. Result = Read Value + Factor
2. Factor = Antenna Factor + Cable Loss - Amplifier
3. The resolution bandwidth of test receiver/spectrum analyzer is 120KHz and video bandwidth is 300kHz for Peak detection and Quasi-peak detection at frequency below 1GHz.
4. The resolution bandwidth of test receiver/spectrum analyzer is 1MHz and video bandwidth is 3MHz for Peak detection at frequency above 1GHz.
5. The resolution bandwidth of test receiver/spectrum analyzer is 1MHz and video bandwidth is 10Hz for Average detection at frequency above 1GHz.
6. The other emissions is too low to be measured.
7. The data is worse case.



Power	: AC 120V	Pol/Phase	: VERTICAL
Test Mode	: Transmit / Receive	Temperature	: 25 °C
Operation Channel	: 39	Humidity	: 60 %
Modulation Type	: 8DPSK	Atmospheric Pressure	: 1007 hPa
Memo	: Adapter: CWT \ KPC-010B	Rate	: 3 Mbps

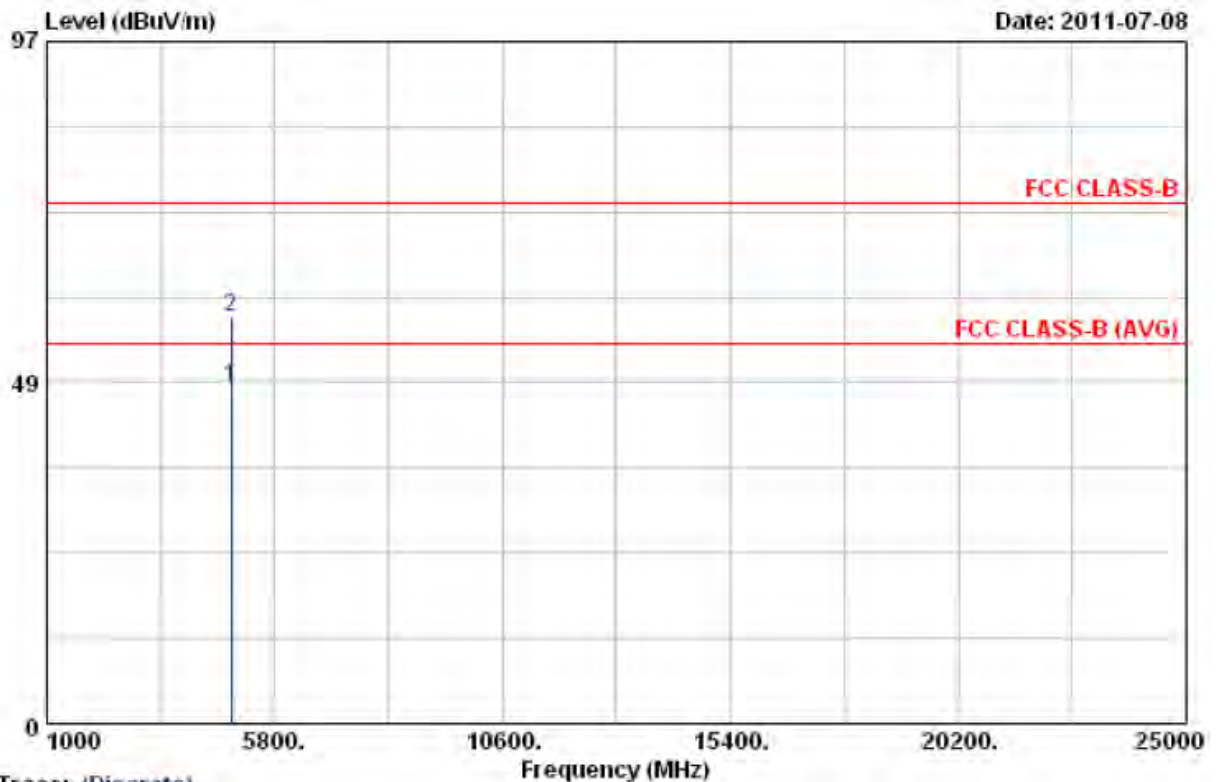

Trace: {Discrete}

Item	Freq	Read Value	Factor	Result	Limit	Margin	Remark	Ant Pos	Tab Pos
	MHz	dBuV	dB/m	dBuV/m	dBuV/m	dB		cm	Deg
1	4881.98	38.88	9.06	47.94	54.00	-6.06	Average	119	240
2	4881.98	48.70	9.06	57.76	74.00	-16.24	Peak	119	240

Notes:

1. Result = Read Value + Factor
2. Factor = Antenna Factor + Cable Loss - Amplifier
3. The resolution bandwidth of test receiver/spectrum analyzer is 120KHz and video bandwidth is 300kHz for Peak detection and Quasi-peak detection at frequency below 1GHz.
4. The resolution bandwidth of test receiver/spectrum analyzer is 1MHz and video bandwidth is 3MHz for Peak detection at frequency above 1GHz.
5. The resolution bandwidth of test receiver/spectrum analyzer is 1MHz and video bandwidth is 10Hz for Average detection at frequency above 1GHz.
6. The other emissions is too low to be measured.
7. The data is worse case.



Power	: AC 120V	Pol/Phase	: HORIZONTAL
Test Mode	: Transmit / Receive	Temperature	: 25 °C
Operation Channel	: 39	Humidity	: 60 %
Modulation Type	: 8DPSK	Atmospheric Pressure	: 1007 hPa
Memo	: Adapter: CWT \ KPC-010B	Rate	: 3 Mbps

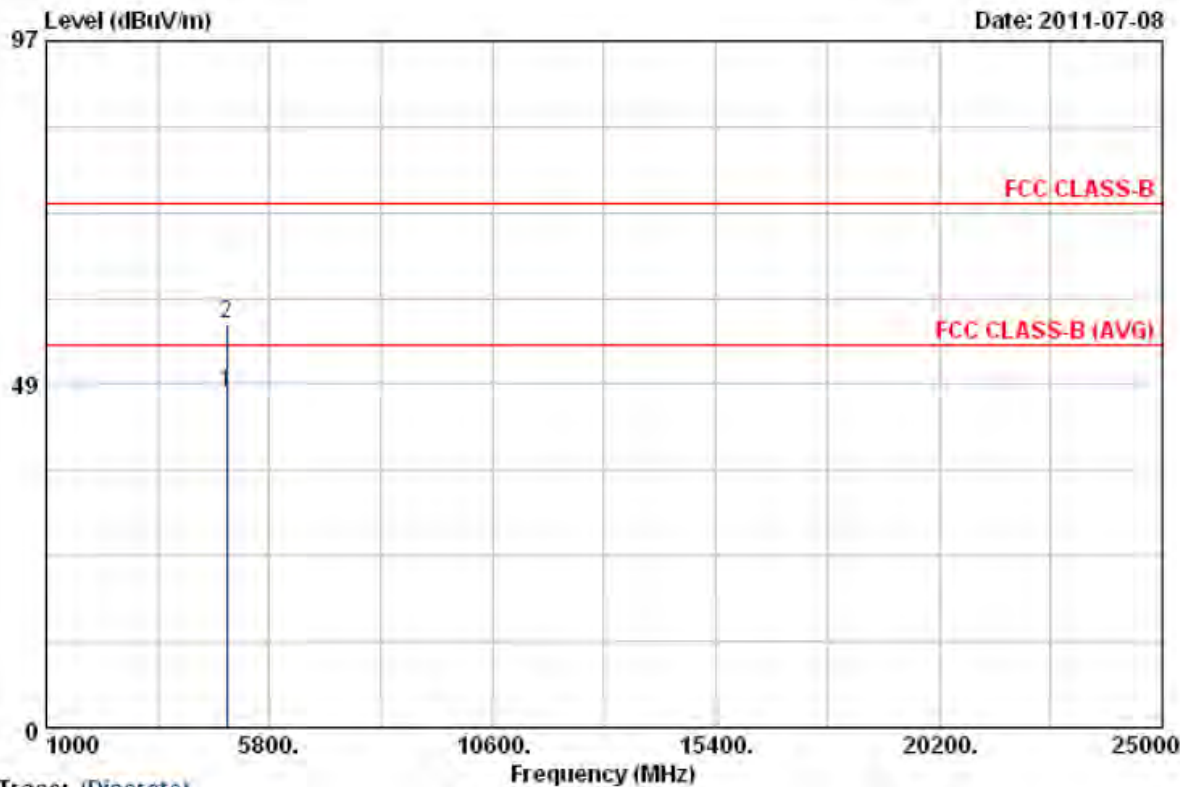

Trace: (Discrete)

Item	Freq	Read Value	Factor	Result	Limit	Margin	Remark	Ant Pos	Tab Pos
	MHz	dBuV	dB/m	dBuV/m	dBuV/m	dB		cm	Deg
1	4882.00	38.19	9.06	47.25	54.00	-6.75	Average	150	250
2	4882.00	48.02	9.06	57.08	74.00	-16.92	Peak	150	250

Notes:

1. Result = Read Value + Factor
2. Factor = Antenna Factor + Cable Loss - Amplifier
3. The resolution bandwidth of test receiver/spectrum analyzer is 120KHz and video bandwidth is 300kHz for Peak detection and Quasi-peak detection at frequency below 1GHz.
4. The resolution bandwidth of test receiver/spectrum analyzer is 1MHz and video bandwidth is 3MHz for Peak detection at frequency above 1GHz.
5. The resolution bandwidth of test receiver/spectrum analyzer is 1MHz and video bandwidth is 10Hz for Average detection at frequency above 1GHz.
6. The other emissions is too low to be measured.
7. The data is worse case.



Power	: AC 120V	Pol/Phase	: VERTICAL
Test Mode	: Transmit / Receive	Temperature	: 25 °C
Operation Channel	: 78	Humidity	: 60 %
Modulation Type	: 8DPSK	Atmospheric Pressure	: 1007 hPa
Memo	: Adapter: CWT \ KPC-010B	Rate	: 3 Mbps

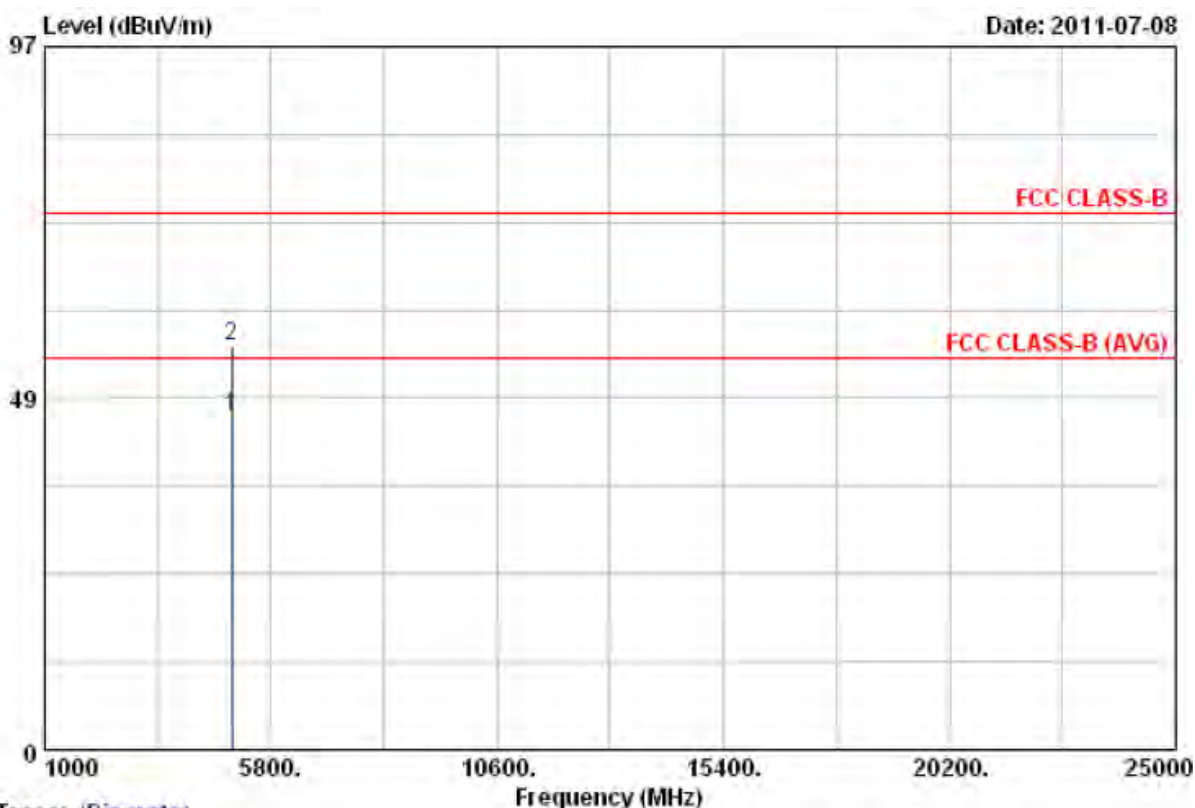

Trace: (Discrete)

Item	Freq MHz	Read Value dBuV	Factor dB/m	Result dBuV/m	Limit dBuV/m	Margin dB	Remark	Ant Pos cm	Tab Pos Deg
1	4960.00	36.56	9.35	45.91	54.00	-8.09	Average	119	240
2	4960.00	46.44	9.35	55.79	74.00	-18.21	Peak	119	240

Notes:

1. Result = Read Value + Factor
2. Factor = Antenna Factor + Cable Loss - Amplifier
3. The resolution bandwidth of test receiver/spectrum analyzer is 120KHz and video bandwidth is 300kHz for Peak detection and Quasi-peak detection at frequency below 1GHz.
4. The resolution bandwidth of test receiver/spectrum analyzer is 1MHz and video bandwidth is 3MHz for Peak detection at frequency above 1GHz.
5. The resolution bandwidth of test receiver/spectrum analyzer is 1MHz and video bandwidth is 10Hz for Average detection at frequency above 1GHz.
6. The other emissions is too low to be measured.
7. The data is worse case.



Power	: AC 120V	Pol/Phase	: HORIZONTAL
Test Mode	: Transmit / Receive	Temperature	: 25 °C
Operation Channel	: 78	Humidity	: 60 %
Modulation Type	: 8DPSK	Atmospheric Pressure	: 1007 hPa
Memo	: Adapter: CWT \ KPC-010B	Rate	: 3 Mbps

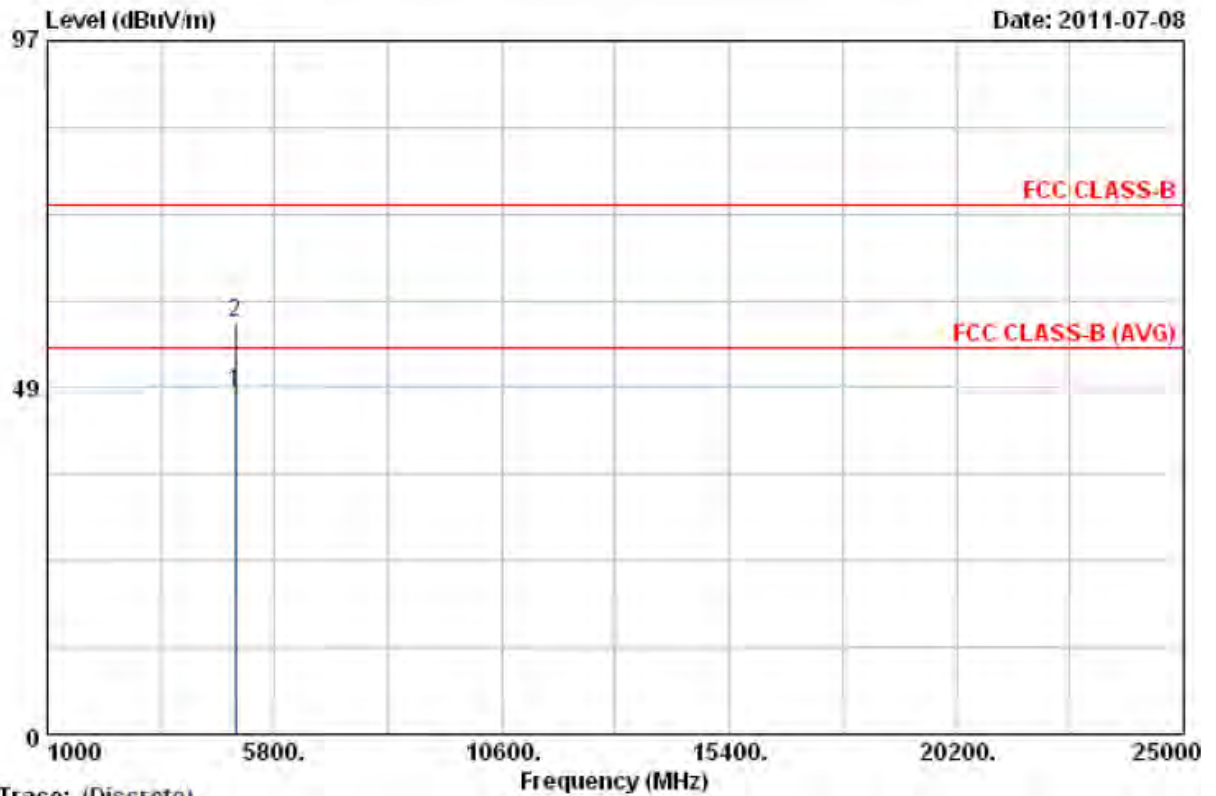

Trace: (Discrete)

Item	Freq	Read Value	Factor	Result	Limit	Margin	Remark	Ant Pos	Tab Pos
	MHz	dBuV	dB/m	dBuV/m	dBuV/m	dB		cm	Deg
1	4960.03	38.56	9.35	47.91	54.00	-6.09	Average	150	250
2	4960.03	48.10	9.35	57.45	74.00	-16.55	Peak	150	250

Notes:

1. Result = Read Value + Factor
2. Factor = Antenna Factor + Cable Loss - Amplifier
3. The resolution bandwidth of test receiver/spectrum analyzer is 120kHz and video bandwidth is 300kHz for Peak detection and Quasi-peak detection at frequency below 1GHz.
4. The resolution bandwidth of test receiver/spectrum analyzer is 1MHz and video bandwidth is 3MHz for Peak detection at frequency above 1GHz.
5. The resolution bandwidth of test receiver/spectrum analyzer is 1MHz and video bandwidth is 10Hz for Average detection at frequency above 1GHz.
6. The other emissions is too low to be measured.
7. The data is worse case.



Power	: AC 120V	Pol/Phase	: VERTICAL
Test Mode	: Transmit / Receive	Temperature	: 23 °C
Operation Channel	: 0	Humidity	: 65 %
Modulation Type	: GFSK	Atmospheric Pressure	: 1020 hPa
Memo	: Adapter: Touch \ M8-10US05R	Rate	: 1 Mbps

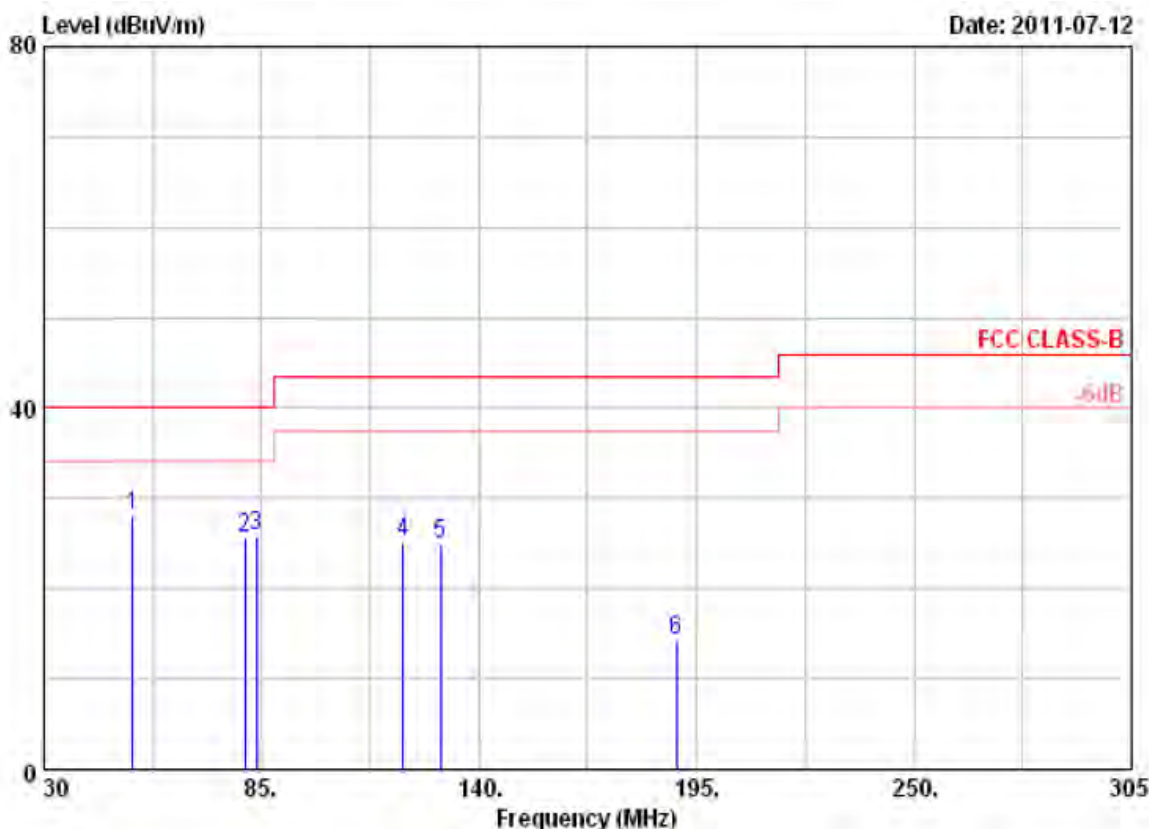

Item	Freq	Read Value	Factor	Result	Limit	Margin	Remark	Ant Pos	Tab Pos
	MHz	dBuV	dB/m	dBuV/m	dBuV/m	dB		cm	Deg
1	52.55	42.60	-14.47	28.13	40.00	-11.87	Peak	100	0
2	80.88	39.49	-13.95	25.54	40.00	-14.46	Peak	100	0
3	83.63	38.65	-12.86	25.79	40.00	-14.21	Peak	100	0
4	120.75	34.57	-9.47	25.10	43.50	-18.40	Peak	100	0
5	130.38	32.61	-7.57	25.04	43.50	-18.46	Peak	100	0
6	190.05	27.95	-13.72	14.23	43.50	-29.27	Peak	100	0

- Remarks:
1. Result = Read Value + Factor
 2. Factor = Antenna Factor + Cable Loss - Amplifier
 3. According to technical experiences, all spurious emission of BT mode at channel 0, 39, 78 are almost the same below 1GHz, so that the channel 0 was chosen as representative in final test.
 4. The data is worst case.



Power	: AC 120V	Pol/Phase	: VERTICAL
Test Mode	: Transmit / Receive	Temperature	: 23 °C
Operation Channel	: 0	Humidity	: 65 %
Modulation Type	: GFSK	Atmospheric Pressure	: 1020 hPa
Memo	: Adapter: Touch \ M8-10US05R	Rate	: 1 Mbps

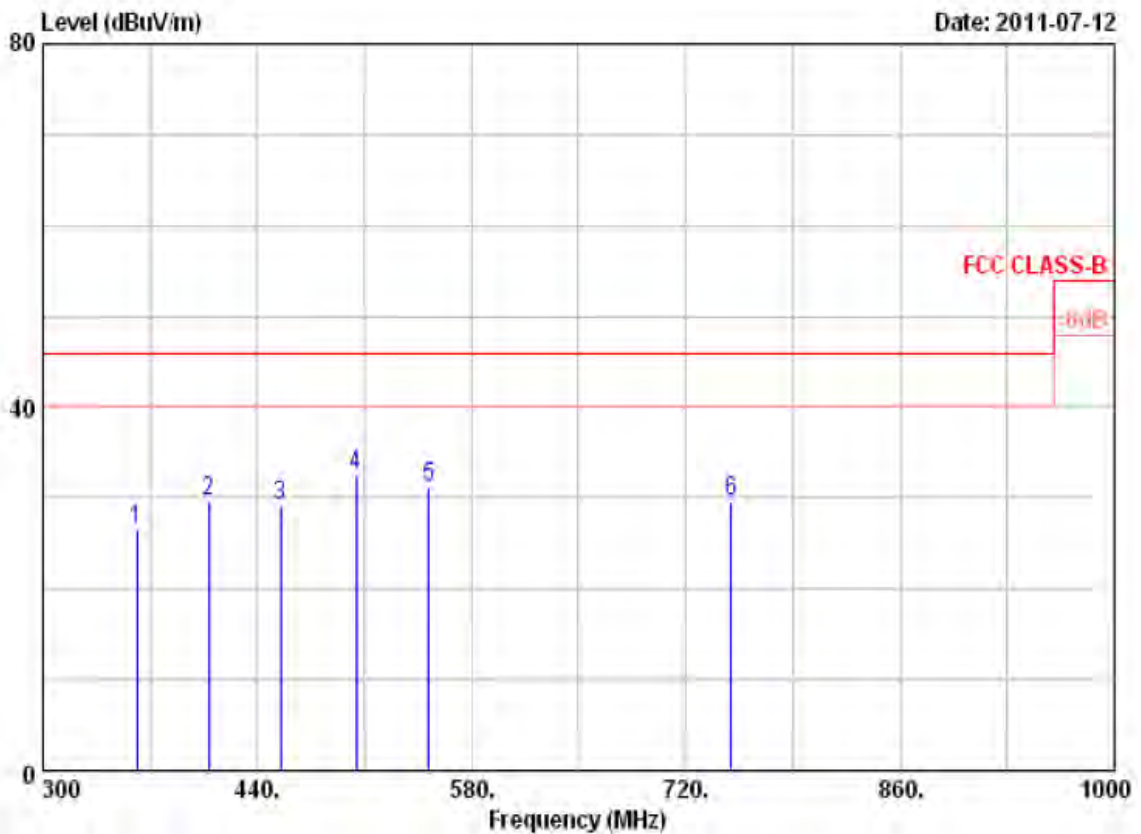

Item	Freq	Read Value	Factor	Result	Limit	Margin	Remark	Ant Pos	Tab Pos
	MHz	dBuV	dB/m	dBuV/m	dBuV/m	dB		cm	Deg
1	361.60	37.64	-11.17	26.47	46.00	-19.53	Peak	100	360
2	408.50	39.69	-10.09	29.60	46.00	-16.40	Peak	100	360
3	455.40	37.72	-8.59	29.13	46.00	-16.87	Peak	100	360
4	504.40	40.90	-8.46	32.44	46.00	-13.56	Peak	100	360
5	552.00	39.65	-8.38	31.27	46.00	-14.73	Peak	100	360
6	749.40	24.47	5.09	29.56	46.00	-16.44	Peak	100	360

- Remarks:
1. Result = Read Value + Factor
 2. Factor = Antenna Factor + Cable Loss - Amplifier
 3. According to technical experiences, all spurious emission of BT mode at channel 0,39,78 are almost the same below 1GHz, so that the channel 0 was chosen as representative in final test.
 4. The data is worst case.



Power	: AC 120V	Pol/Phase	: HORIZONTAL
Test Mode	: Transmit / Receive	Temperature	: 23 °C
Operation Channel	: 0	Humidity	: 65 %
Modulation Type	: GFSK	Atmospheric Pressure	: 1020 hPa
Memo	: Adapter: Touch \ M8-10US05R	Rate	: 1 Mbps

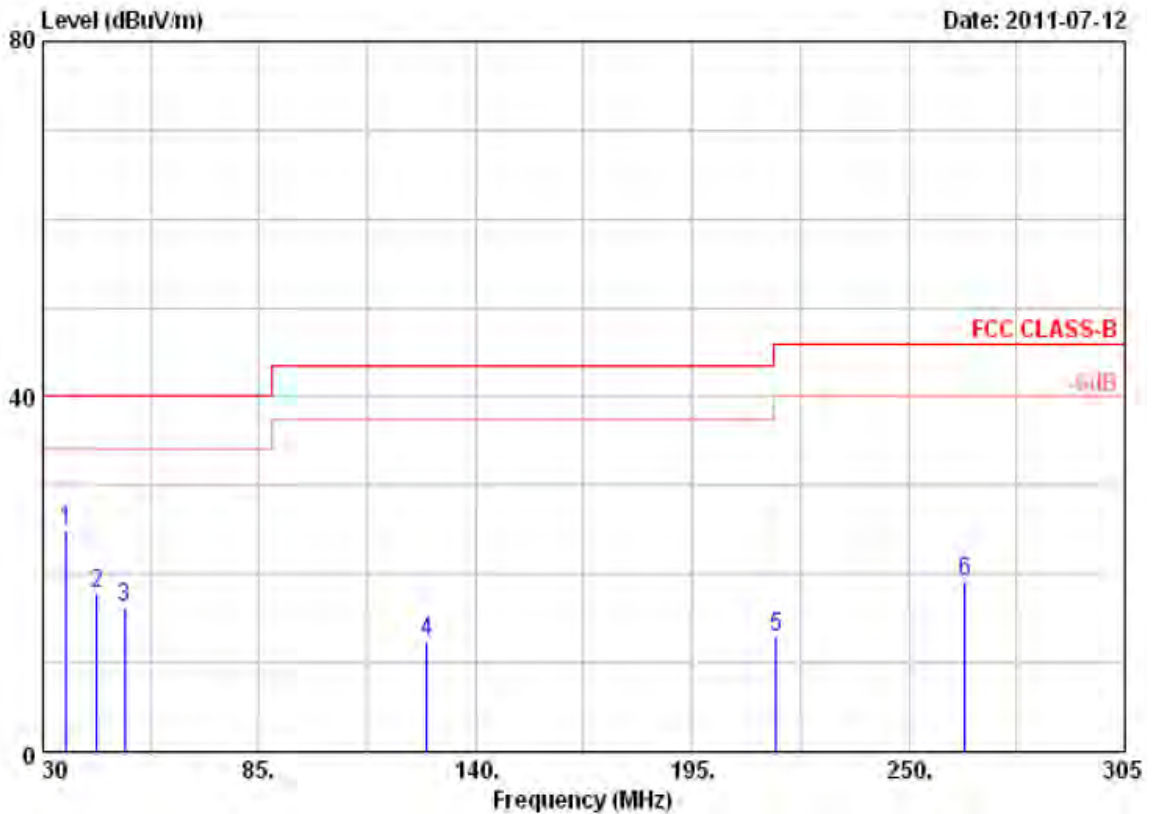

Item	Freq	Read Value	Factor	Result	Limit	Margin	Remark	Ant Pos	Tab Pos
	MHz	dBuV	dB/m	dBuV/m	dBuV/m	dB		cm	Deg
1	36.05	32.66	-7.76	24.90	40.00	-15.10	Peak	100	0
2	43.75	31.65	-13.79	17.86	40.00	-22.14	Peak	100	0
3	50.63	30.64	-14.27	16.37	40.00	-23.63	Peak	100	0
4	127.63	28.65	-16.07	12.58	43.50	-30.92	Peak	100	0
5	216.45	29.40	-16.55	12.85	46.00	-33.15	Peak	100	0
6	264.30	34.32	-15.13	19.19	46.00	-26.81	Peak	100	0

- Remarks:
1. Result = Read Value + Factor
 2. Factor = Antenna Factor + Cable Loss - Amplifier
 3. According to technical experiences, all spurious emission of BT mode at channel 0,39,78 are almost the same below 1GHz, so that the channel 0 was chosen as representative in final test.
 4. The data is worst case.



Power	: AC 120V	Pol/Phase	: HORIZONTAL
Test Mode	: Transmit / Receive	Temperature	: 23 °C
Operation Channel	: 0	Humidity	: 65 %
Modulation Type	: GFSK	Atmospheric Pressure	: 1020 hPa
Memo	: Adapter: Touch \ M8-10US05R	Rate	: 1 Mbps

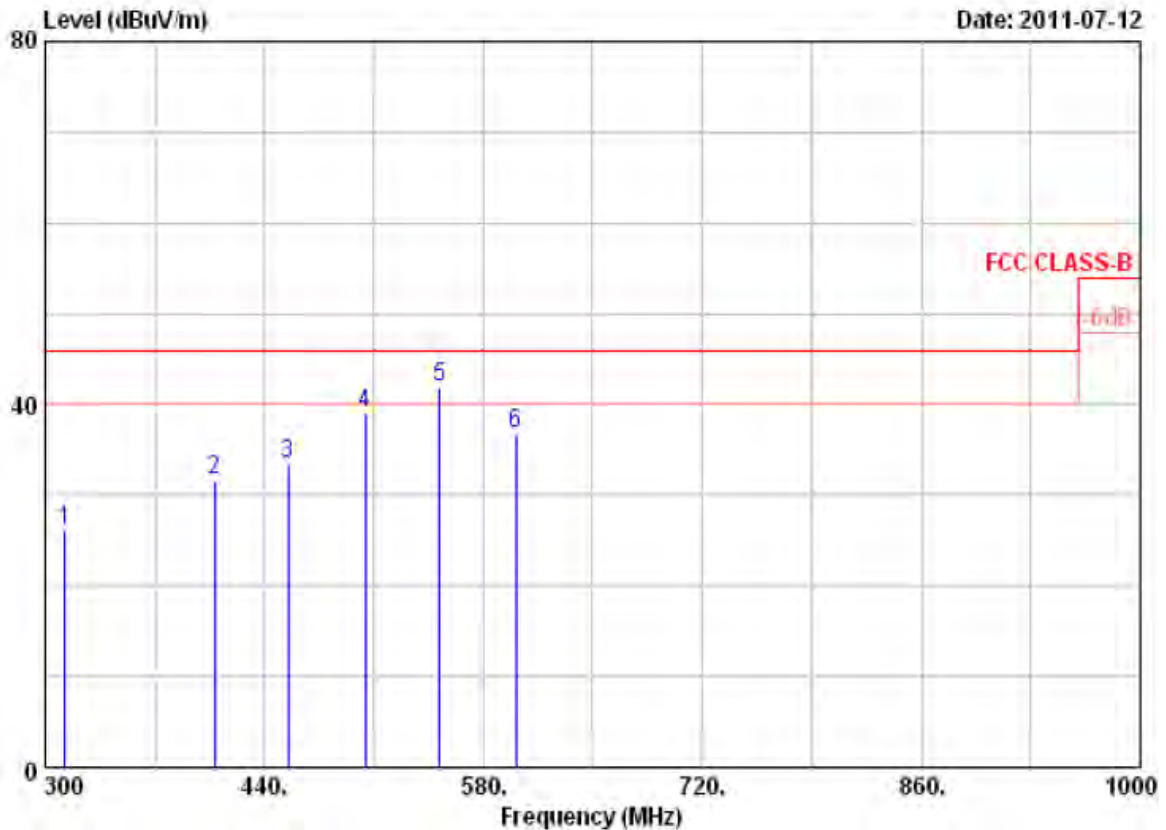

Item	Freq	Read Value	Factor	Result	Limit	Margin	Remark	Ant Pos	Tab Pos
	MHz	dBuV	dB/m	dBuV/m	dBuV/m	dB		cm	Deg
1	312.60	40.15	-14.00	26.15	46.00	-19.85	Peak	100	360
2	408.50	41.91	-10.33	31.58	46.00	-14.42	Peak	100	360
3	455.40	41.66	-8.31	33.35	46.00	-12.65	Peak	100	360
4	504.40	43.57	-4.54	39.03	46.00	-6.97	Peak	100	360
5	552.00	42.65	-0.76	41.89	46.00	-4.11	QP	100	360
6	601.00	36.27	0.42	36.69	46.00	-9.31	Peak	100	360

- Remarks:
1. Result = Read Value + Factor
 2. Factor = Antenna Factor + Cable Loss - Amplifier
 3. According to technical experiences, all spurious emission of BT mode at channel 0,39,78 are almost the same below 1GHz, so that the channel 0 was chosen as representative in final test.
 4. The data is worst case.



Power	: AC 120V	Pol/Phase	: VERTICAL
Test Mode	: Transmit / Receive	Temperature	: 25 °C
Operation Channel	: 0	Humidity	: 60 %
Modulation Type	: GFSK	Atmospheric Pressure	: 1020 hPa
Memo	: Adapter: Touch \ M8-10US05R	Rate	: 1 Mbps

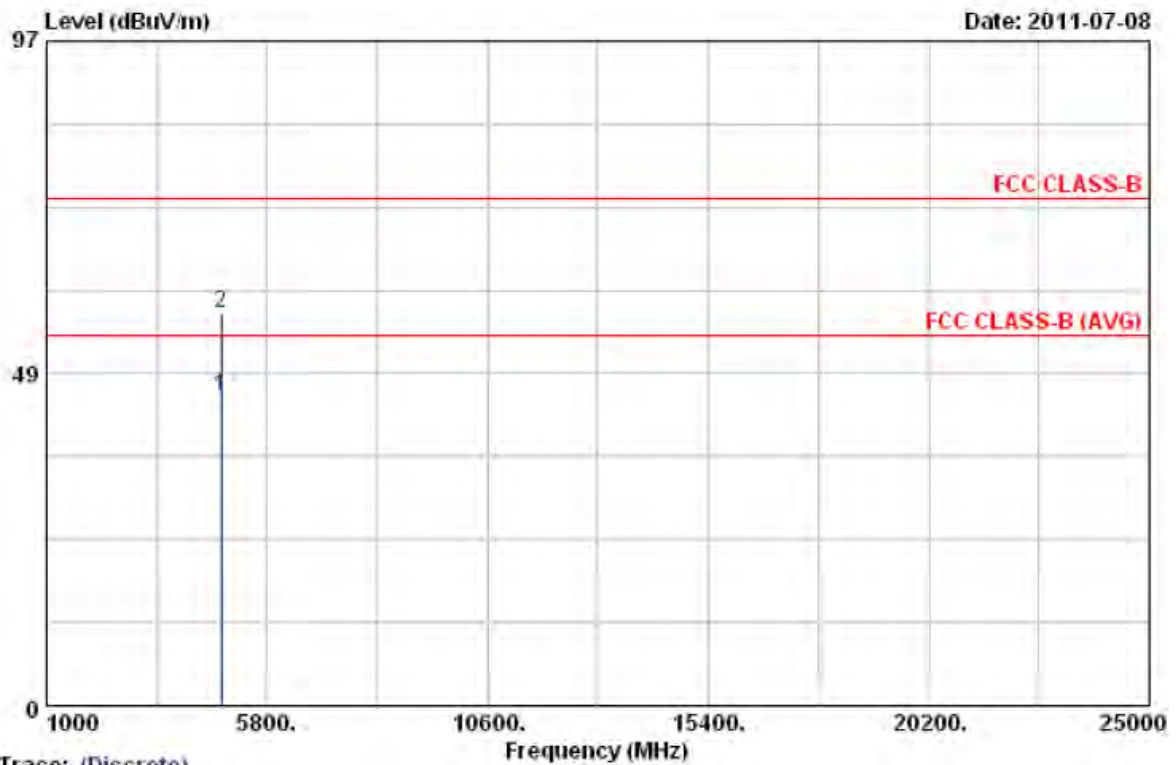

Trace: (Discrete)

Item	Freq	Read Value	Factor	Result	Limit	Margin	Remark	Ant Pos	Tab Pos
	MHz	dBuV	dB/m	dBuV/m	dBuV/m	dB		cm	Deg
1	4804.03	36.28	8.76	45.04	54.00	-8.96	Average	119	240
2	4804.03	48.57	8.76	57.33	74.00	-16.67	Peak	119	240

Notes:

1. Result = Read Value + Factor
2. Factor = Antenna Factor + Cable Loss - Amplifier
3. The resolution bandwidth of test receiver/spectrum analyzer is 120KHz and video bandwidth is 300kHz for Peak detection and Quasi-peak detection at frequency below 1GHz.
4. The resolution bandwidth of test receiver/spectrum analyzer is 1MHz and video bandwidth is 3MHz for Peak detection at frequency above 1GHz.
5. The resolution bandwidth of test receiver/spectrum analyzer is 1MHz and video bandwidth is 10Hz for Average detection at frequency above 1GHz.
6. The other emissions is too low to be measured.
7. The data is worse case.



Power	: AC 120V	Pol/Phase	: HORIZONTAL
Test Mode	: Transmit / Receive	Temperature	: 25 °C
Operation Channel	: 0	Humidity	: 60 %
Modulation Type	: GFSK	Atmospheric Pressure	: 1020 hPa
Memo	: Adapter: Touch \ M8-10US05R	Rate	: 1 Mbps

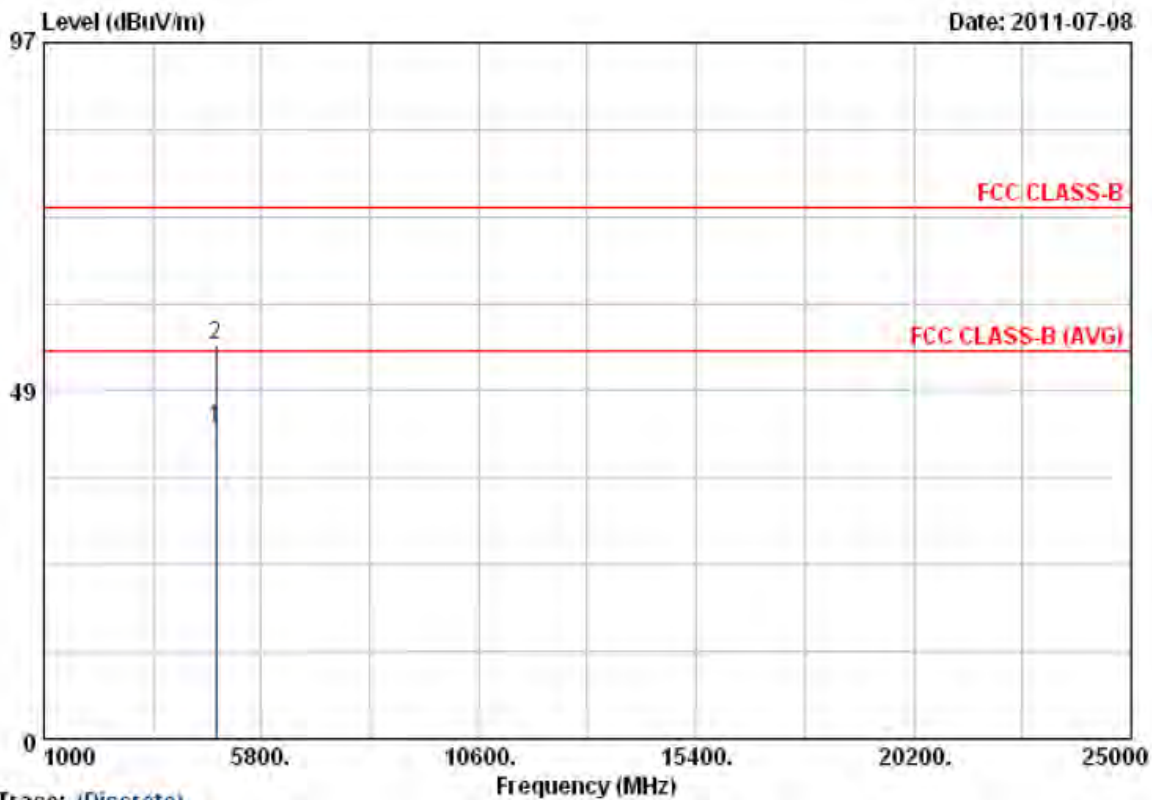

Trace: (Discrete)

Item	Freq	Read Value	Factor	Result	Limit	Margin	Remark	Ant Pos	Tab Pos
	MHz	dBuV	dB/m	dBuV/m	dBuV/m	dB		cm	Deg
1	4803.95	34.55	8.76	43.31	54.00	-10.69	Average	150	250
2	4803.95	46.16	8.76	54.92	74.00	-19.08	Peak	150	250

Notes:

1. Result = Read Value + Factor
2. Factor = Antenna Factor + Cable Loss - Amplifier
3. The resolution bandwidth of test receiver/spectrum analyzer is 120KHz and video bandwidth is 300kHz for Peak detection and Quasi-peak detection at frequency below 1GHz.
4. The resolution bandwidth of test receiver/spectrum analyzer is 1MHz and video bandwidth is 3MHz for Peak detection at frequency above 1GHz.
5. The resolution bandwidth of test receiver/spectrum analyzer is 1MHz and video bandwidth is 10Hz for Average detection at frequency above 1GHz.
6. The other emissions is too low to be measured.
7. The data is worse case.



Power	: AC 120V	Pol/Phase	: VERTICAL
Test Mode	: Transmit / Receive	Temperature	: 25 °C
Operation Channel	: 39	Humidity	: 60 %
Modulation Type	: GFSK	Atmospheric Pressure	: 1020 hPa
Memo	: Adapter: Touch \ M8-10US05R	Rate	: 1 Mbps

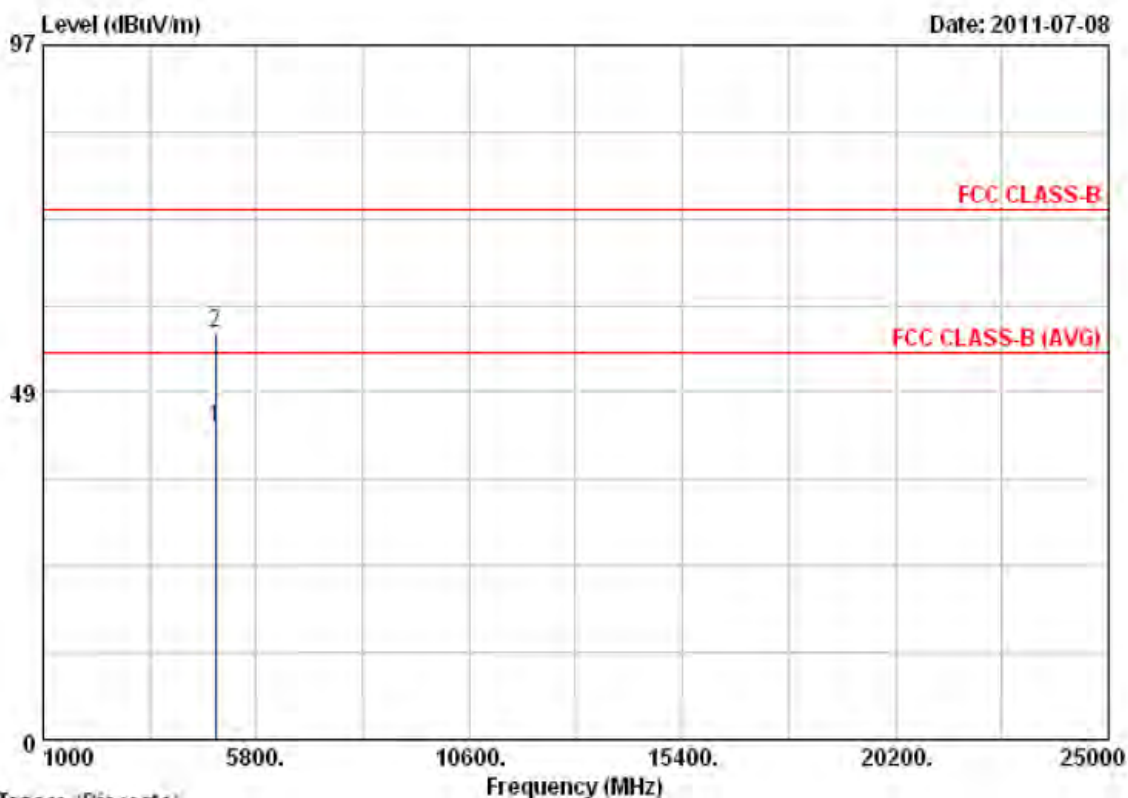

Trace: (Discrete)

Item	Freq	Read Value	Factor	Result	Limit	Margin	Remark	Ant Pos	Tab Pos
	MHz	dBuV	dB/m	dBuV/m	dBuV/m	dB		cm	Deg
1	4882.03	34.55	9.06	43.61	54.00	-10.39	Average	119	240
2	4882.03	47.59	9.06	56.65	74.00	-17.35	Peak	119	240

Notes:

1. Result = Read Value + Factor
2. Factor = Antenna Factor + Cable Loss - Amplifier
3. The resolution bandwidth of test receiver/spectrum analyzer is 120KHz and video bandwidth is 300kHz for Peak detection and Quasi-peak detection at frequency below 1GHz.
4. The resolution bandwidth of test receiver/spectrum analyzer is 1MHz and video bandwidth is 3MHz for Peak detection at frequency above 1GHz.
5. The resolution bandwidth of test receiver/spectrum analyzer is 1MHz and video bandwidth is 10Hz for Average detection at frequency above 1GHz.
6. The other emissions is too low to be measured.
7. The data is worse case.



Power	: AC 120V	Pol/Phase	: HORIZONTAL
Test Mode	: Transmit / Receive	Temperature	: 25 °C
Operation Channel	: 39	Humidity	: 60 %
Modulation Type	: GFSK	Atmospheric Pressure	: 1020 hPa
Memo	: Adapter: Touch \ M8-10US05R	Rate	: 1 Mbps

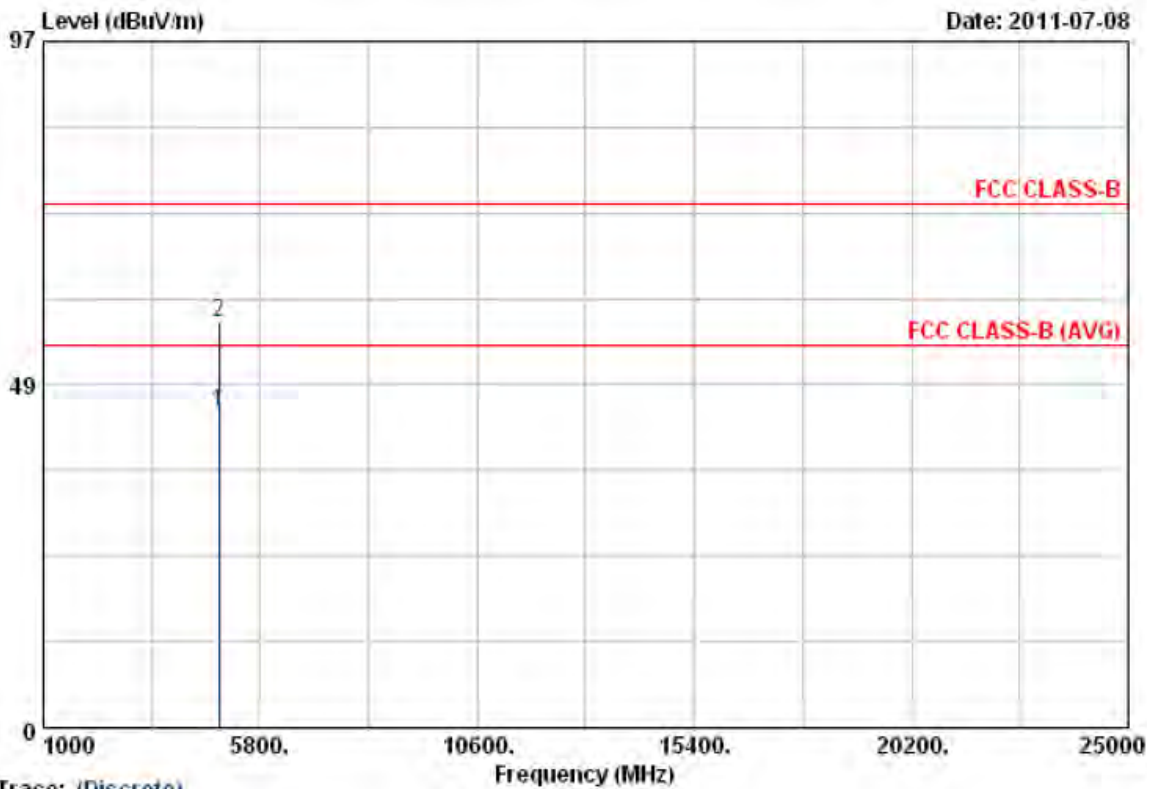

Trace: (Discrete)

Item	Freq	Read Value	Factor	Result	Limit	Margin	Remark	Ant Pos	Tab Pos
	MHz	dBuV	dB/m	dBuV/m	dBuV/m	dB		cm	Deg
1	4882.08	35.54	9.06	44.60	54.00	-9.40	Average	150	250
2	4882.08	48.16	9.06	57.22	74.00	-16.78	Peak	150	250

Notes:

1. Result = Read Value + Factor
2. Factor = Antenna Factor + Cable Loss - Amplifier
3. The resolution bandwidth of test receiver/spectrum analyzer is 120KHz and video bandwidth is 300kHz for Peak detection and Quasi-peak detection at frequency below 1GHz.
4. The resolution bandwidth of test receiver/spectrum analyzer is 1MHz and video bandwidth is 3MHz for Peak detection at frequency above 1GHz.
5. The resolution bandwidth of test receiver/spectrum analyzer is 1MHz and video bandwidth is 10Hz for Average detection at frequency above 1GHz.
6. The other emissions is too low to be measured.
7. The data is worse case.



Power	: AC 120V	Pol/Phase	: VERTICAL
Test Mode	: Transmit / Receive	Temperature	: 25 °C
Operation Channel	: 78	Humidity	: 60 %
Modulation Type	: GFSK	Atmospheric Pressure	: 1020 hPa
Memo	: Adapter: Touch \ M8-10US05R	Rate	: 1 Mbps

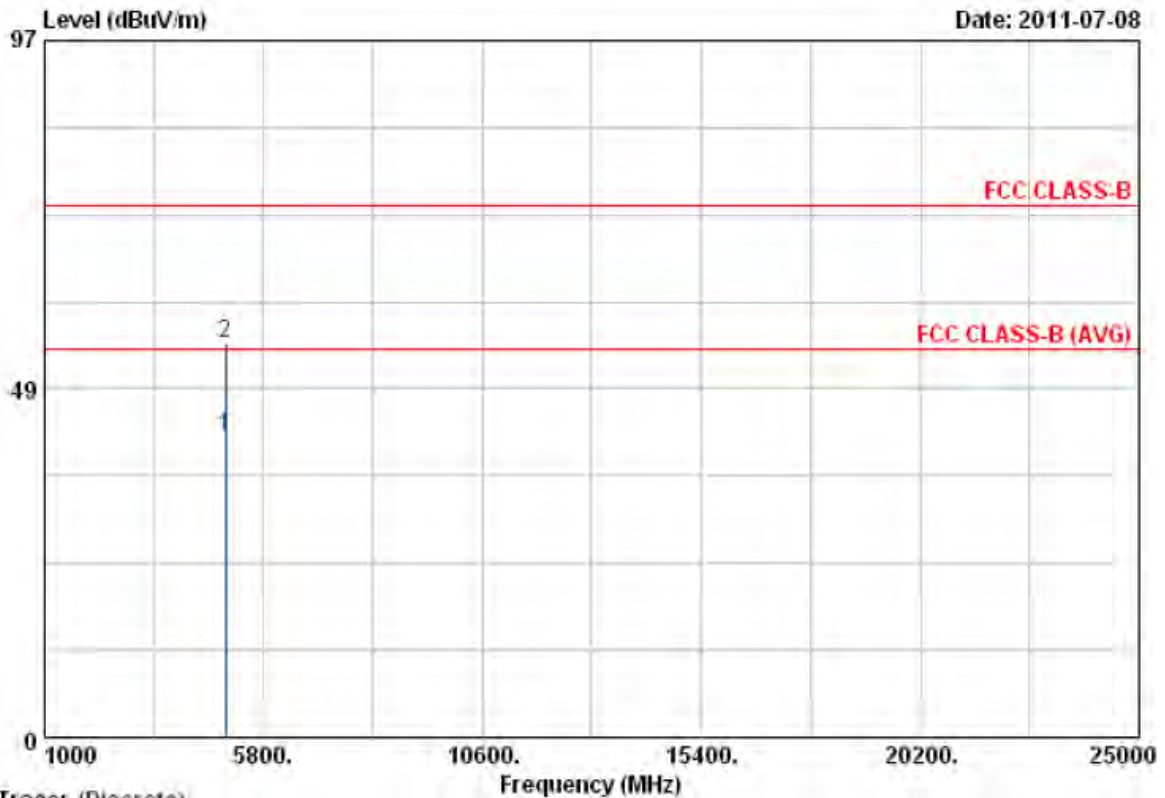

Trace: (Discrete)

Item	Freq	Read Value	Factor	Result	Limit	Margin	Remark	Ant Pos	Tab Pos
	MHz	dBuV	dB/m	dBuV/m	dBuV/m	dB		cm	Deg
1	4959.93	32.66	9.35	42.01	54.00	-11.99	Average	119	240
2	4959.93	45.37	9.35	54.72	74.00	-19.28	Peak	119	240

Notes:

1. Result = Read Value + Factor
2. Factor = Antenna Factor + Cable Loss - Amplifier
3. The resolution bandwidth of test receiver/spectrum analyzer is 120KHz and video bandwidth is 300kHz for Peak detection and Quasi-peak detection at frequency below 1GHz.
4. The resolution bandwidth of test receiver/spectrum analyzer is 1MHz and video bandwidth is 3MHz for Peak detection at frequency above 1GHz.
5. The resolution bandwidth of test receiver/spectrum analyzer is 1MHz and video bandwidth is 10Hz for Average detection at frequency above 1GHz.
6. The other emissions is too low to be measured.
7. The data is worse case.



Power	: AC 120V	Pol/Phase	: HORIZONTAL
Test Mode	: Transmit / Receive	Temperature	: 25 °C
Operation Channel	: 78	Humidity	: 60 %
Modulation Type	: GFSK	Atmospheric Pressure	: 1020 hPa
Memo	: Adapter: Touch \ M8-10US05R	Rate	: 1 Mbps

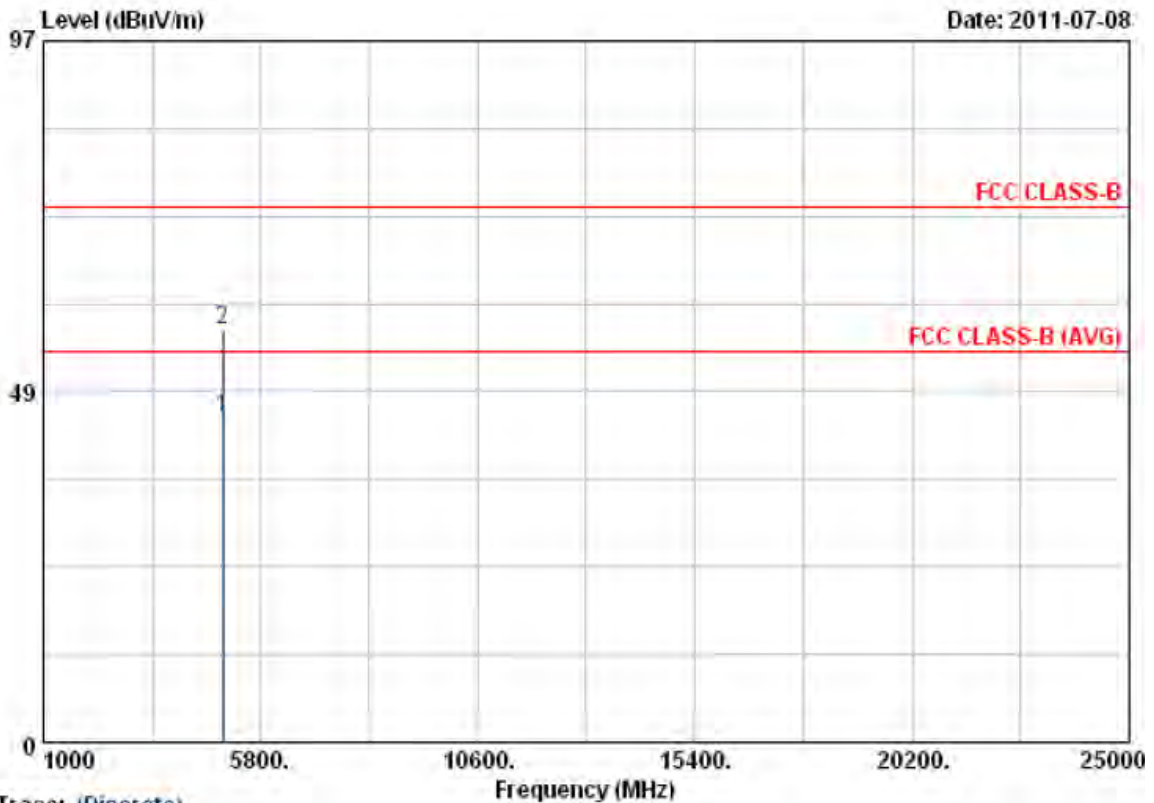

Trace: (Discrete)

Item	Freq	Read Value	Factor	Result	Limit	Margin	Remark	Ant Pos	Tab Pos
	MHz	dBuV	dB/m	dBuV/m	dBuV/m	dB		cm	Deg
1	4960.05	35.37	9.35	44.72	54.00	-9.28	Average	150	250
2	4960.05	47.67	9.35	57.02	74.00	-16.98	Peak	150	250

Notes:

1. Result = Read Value + Factor
2. Factor = Antenna Factor + Cable Loss - Amplifier
3. The resolution bandwidth of test receiver/spectrum analyzer is 120KHz and video bandwidth is 300kHz for Peak detection and Quasi-peak detection at frequency below 1GHz.
4. The resolution bandwidth of test receiver/spectrum analyzer is 1MHz and video bandwidth is 3MHz for Peak detection at frequency above 1GHz.
5. The resolution bandwidth of test receiver/spectrum analyzer is 1MHz and video bandwidth is 10Hz for Average detection at frequency above 1GHz.
6. The other emissions is too low to be measured.
7. The data is worse case.



Power	: AC 120V	Pol/Phase	: VERTICAL
Test Mode	: Transmit / Receive	Temperature	: 23 °C
Operation Channel	: 0	Humidity	: 65 %
Modulation Type	: $\pi/4$ -DQPSK	Atmospheric Pressure	: 1020 hPa
Memo	: Adapter: Touch \ M8-10US05R	Rate	: 2 Mbps

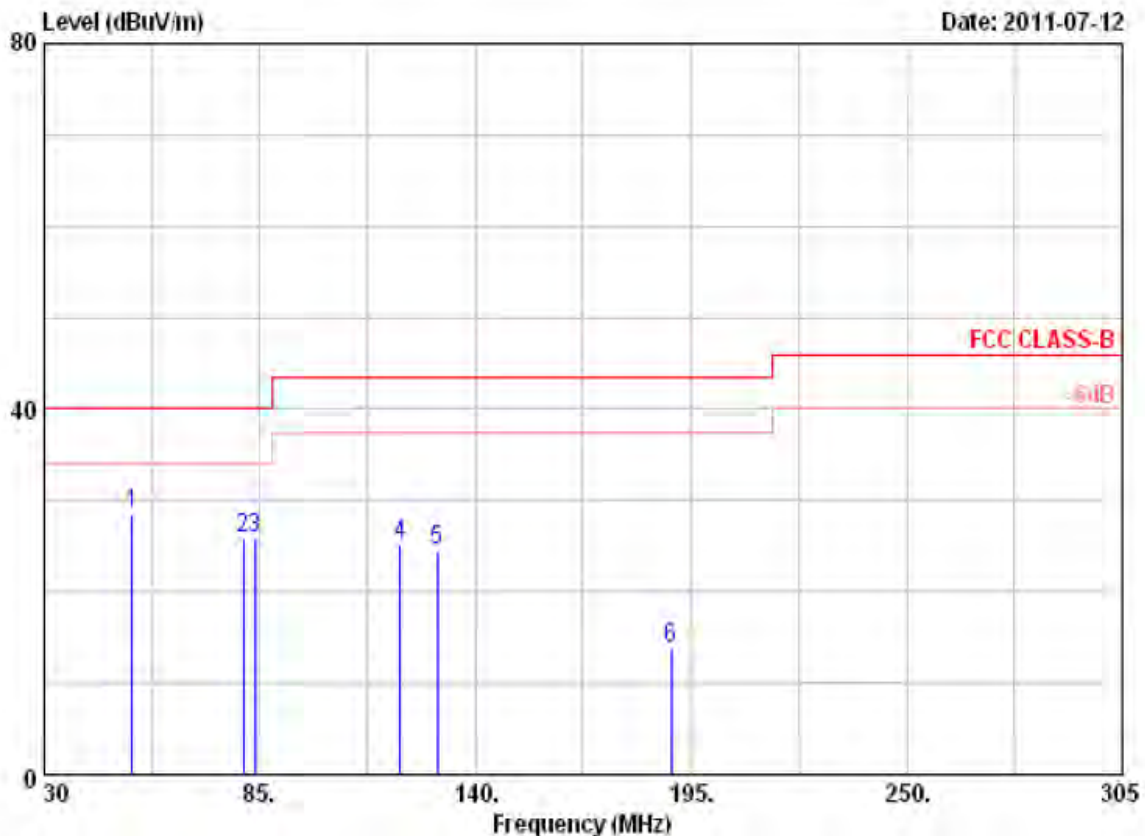

Item	Freq	Read Value	Factor	Result	Limit	Margin	Remark	Ant Pos	Tab Pos
	MHz	dBuV	dB/m	dBuV/m	dBuV/m	dB		cm	Deg
1	52.55	42.89	-14.47	28.42	40.00	-11.58	Peak	100	0
2	80.88	39.85	-13.95	25.90	40.00	-14.10	Peak	100	0
3	83.63	38.64	-12.86	25.78	40.00	-14.22	Peak	100	0
4	120.75	34.67	-9.47	25.20	43.50	-18.30	Peak	100	0
5	130.38	32.01	-7.57	24.44	43.50	-19.06	Peak	100	0
6	190.05	27.55	-13.72	13.83	43.50	-29.67	Peak	100	0

- Remarks:
1. Result = Read Value + Factor
 2. Factor = Antenna Factor + Cable Loss - Amplifier
 3. According to technical experiences, all spurious emission of BT mode at channel 0,39,78 are almost the same below 1GHz, so that the channel 0 was chosen as representative in final test.
 4. The data is worst case.



Power	: AC 120V	Pol/Phase	: VERTICAL
Test Mode	: Transmit / Receive	Temperature	: 23 °C
Operation Channel	: 0	Humidity	: 65 %
Modulation Type	: $\pi/4$ -DQPSK	Atmospheric Pressure	: 1020 hPa
Memo	: Adapter: Touch \ M8-10US05R	Rate	: 2 Mbps

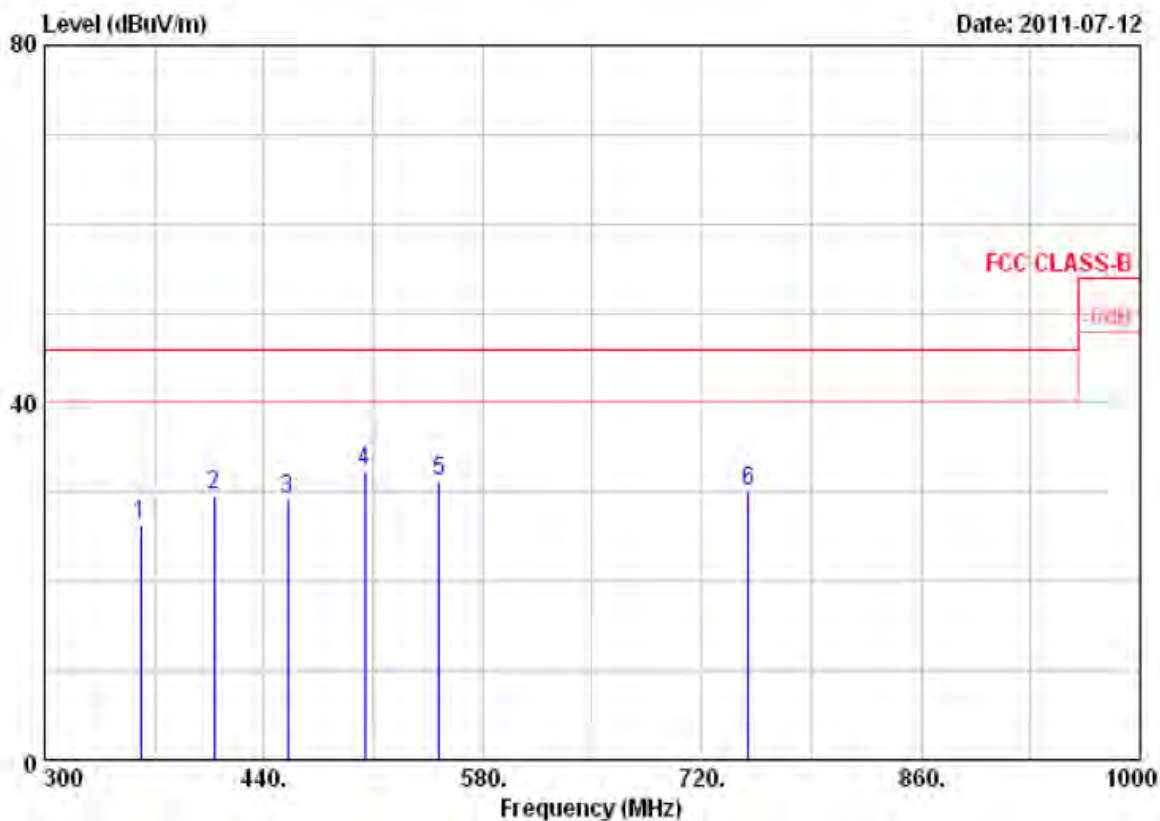

Item	Freq	Read Value	Factor	Result	Limit	Margin	Remark	Ant Pos	Tab Pos
	MHz	dBuV	dB/m	dBuV/m	dBuV/m	dB		cm	Deg
1	361.60	37.48	-11.17	26.31	46.00	-19.69	Peak	100	360
2	408.50	39.64	-10.09	29.55	46.00	-16.45	Peak	100	360
3	455.40	37.82	-8.59	29.23	46.00	-16.77	Peak	100	360
4	504.40	40.69	-8.46	32.23	46.00	-13.77	Peak	100	360
5	552.00	39.65	-8.38	31.27	46.00	-14.73	Peak	100	360
6	749.40	24.99	5.09	30.08	46.00	-15.92	Peak	100	360

- Remarks:
1. Result = Read Value + Factor
 2. Factor = Antenna Factor + Cable Loss - Amplifier
 3. According to technical experiences, all spurious emission of BT mode at channel 0, 39, 78 are almost the same below 1GHz, so that the channel 0 was chosen as representative in final test.
 4. The data is worst case.



Power	: AC 120V	Pol/Phase	: HORIZONTAL
Test Mode	: Transmit / Receive	Temperature	: 23 °C
Operation Channel	: 0	Humidity	: 65 %
Modulation Type	: $\pi/4$ -DQPSK	Atmospheric Pressure	: 1020 hPa
Memo	: Adapter: Touch \ M8-10US05R	Rate	: 2 Mbps

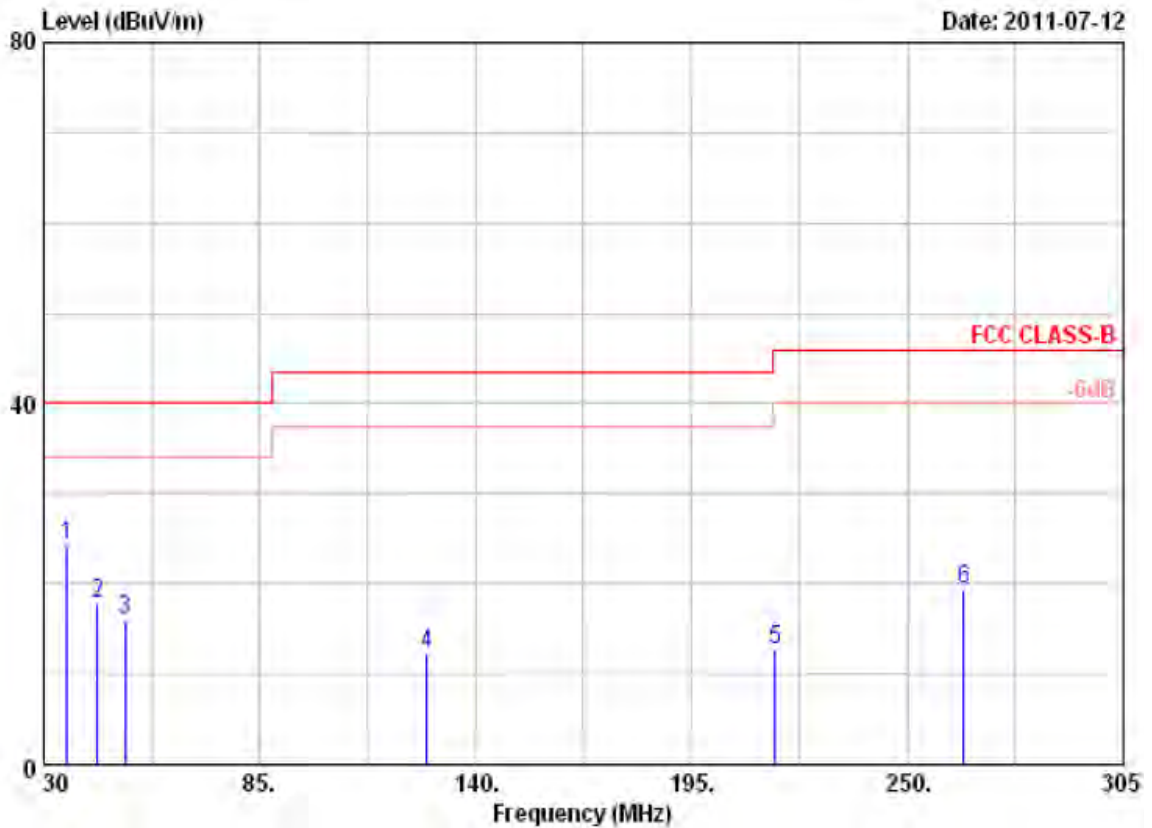

Item	Freq	Read Value	Factor	Result	Limit	Margin	Remark	Ant Pos	Tab Pos
	MHz	dBuV	dB/m	dBuV/m	dBuV/m	dB		cm	Deg
1	36.05	32.11	-7.76	24.35	40.00	-15.65	Peak	100	0
2	43.75	31.67	-13.79	17.88	40.00	-22.12	Peak	100	0
3	50.63	30.31	-14.27	16.04	40.00	-23.96	Peak	100	0
4	127.63	28.33	-16.07	12.26	43.50	-31.24	Peak	100	0
5	216.45	29.18	-16.55	12.63	46.00	-33.37	Peak	100	0
6	264.30	34.46	-15.13	19.33	46.00	-26.67	Peak	100	0

Remarks:

1. Result = Read Value + Factor
2. Factor = Antenna Factor + Cable Loss - Amplifier
3. According to technical experiences, all spurious emission of BT mode at channel 0, 39, 78 are almost the same below 1GHz, so that the channel 0 was chosen as representative in final test.
4. The data is worst case.



Power	: AC 120V	Pol/Phase	: HORIZONTAL
Test Mode	: Transmit / Receive	Temperature	: 23 °C
Operation Channel	: 0	Humidity	: 65 %
Modulation Type	: $\pi/4$ -DQPSK	Atmospheric Pressure	: 1020 hPa
Memo	: Adapter: Touch \ M8-10US05R	Rate	: 2 Mbps

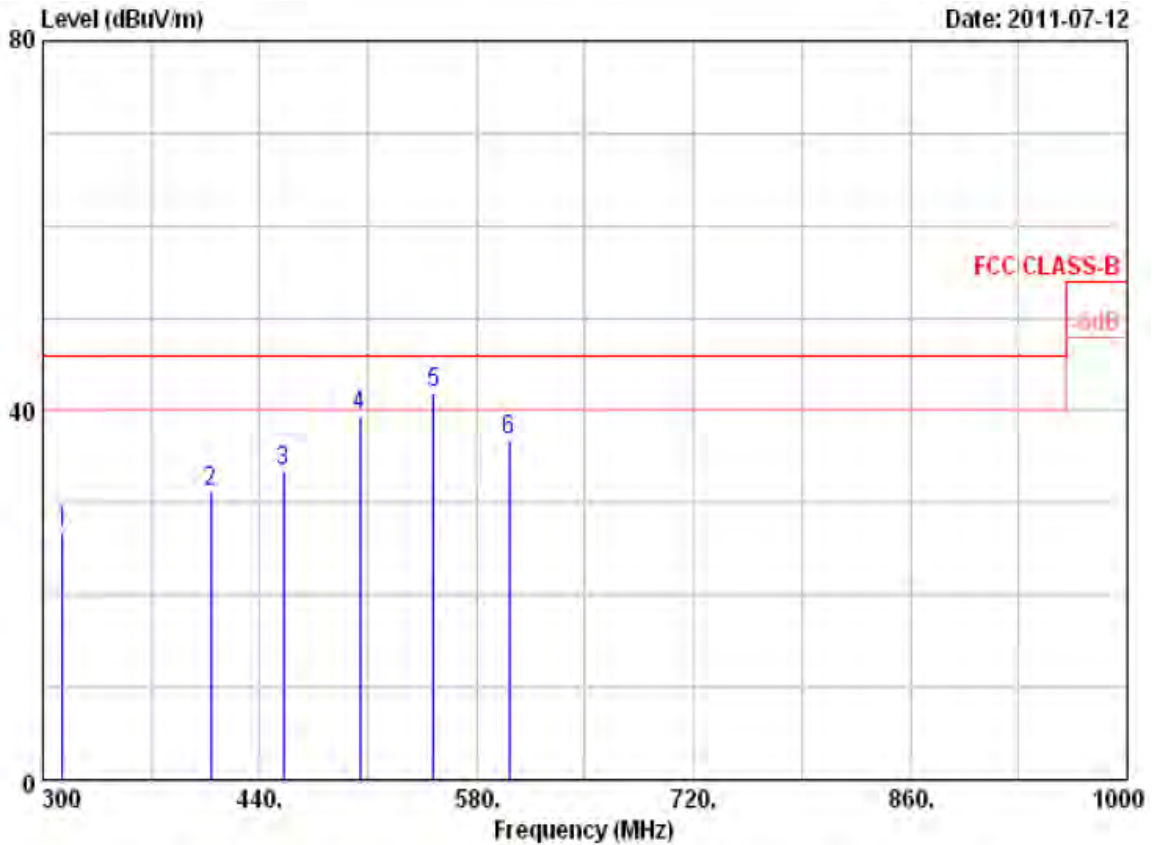

Item	Freq	Read Value	Factor	Result	Limit	Margin	Remark	Ant Pos	Tab Pos
	MHz	dBuV	dB/m	dBuV/m	dBuV/m	dB		cm	Deg
1	312.60	40.64	-14.00	26.64	46.00	-19.36	Peak	100	360
2	408.50	41.61	-10.33	31.28	46.00	-14.72	Peak	100	360
3	455.40	41.67	-8.31	33.36	46.00	-12.64	Peak	100	360
4	504.40	43.90	-4.54	39.36	46.00	-6.64	Peak	100	360
5	552.00	42.65	-0.76	41.89	46.00	-4.11	QP	100	360
6	601.00	36.45	0.42	36.87	46.00	-9.13	Peak	100	360

- Remarks:
1. Result = Read Value + Factor
 2. Factor = Antenna Factor + Cable Loss - Amplifier
 3. According to technical experiences, all spurious emission of BT mode at channel 0,39,78 are almost the same below 1GHz, so that the channel 0 was chosen as representative in final test.
 4. The data is worst case.



Power	: AC 120V	Pol/Phase	: VERTICAL
Test Mode	: Transmit / Receive	Temperature	: 25 °C
Operation Channel	: 0	Humidity	: 60 %
Modulation Type	: $\pi/4$ -DQPSK	Atmospheric Pressure	: 1020 hPa
Memo	: Adapter: Touch \ M8-10US05R	Rate	: 2 Mbps

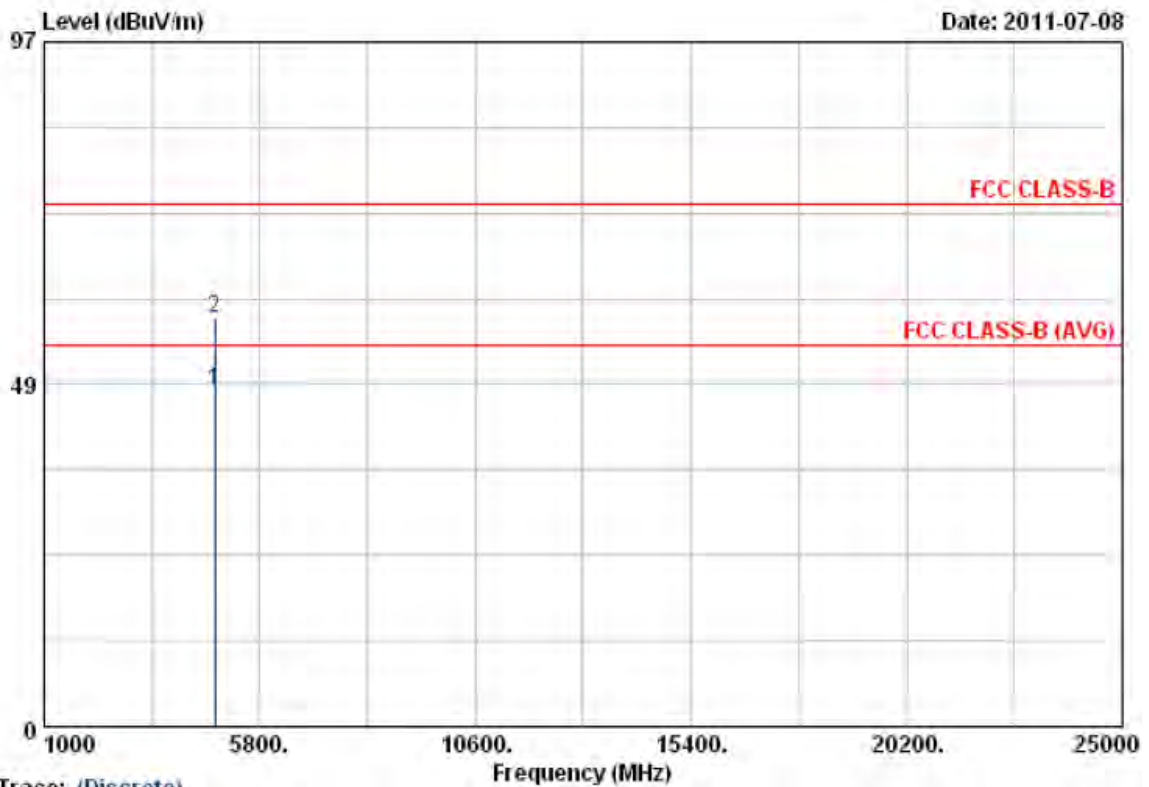

Trace: (Discrete)

Item	Freq	Read Value	Factor	Result	Limit	Margin	Remark	Ant Pos	Tab Pos
	MHz	dBuV	dB/m	dBuV/m	dBuV/m	dB		cm	Deg
1	4803.98	38.88	8.76	47.64	54.00	-6.36	Average	119	240
2	4803.98	48.96	8.76	57.72	74.00	-16.28	Peak	119	240

Notes:

1. Result = Read Value + Factor
2. Factor = Antenna Factor + Cable Loss - Amplifier
3. The resolution bandwidth of test receiver/spectrum analyzer is 120kHz and video bandwidth is 300kHz for Peak detection and Quasi-peak detection at frequency below 1GHz.
4. The resolution bandwidth of test receiver/spectrum analyzer is 1MHz and video bandwidth is 3MHz for Peak detection at frequency above 1GHz.
5. The resolution bandwidth of test receiver/spectrum analyzer is 1MHz and video bandwidth is 10Hz for Average detection at frequency above 1GHz.
6. The other emissions is too low to be measured.
7. The data is worse case.



Power	: AC 120V	Pol/Phase	: HORIZONTAL
Test Mode	: Transmit / Receive	Temperature	: 25 °C
Operation Channel	: 0	Humidity	: 60 %
Modulation Type	: $\pi/4$ -DQPSK	Atmospheric Pressure	: 1020 hPa
Memo	: Adapter: Touch \ M8-10US05R	Rate	: 2 Mbps

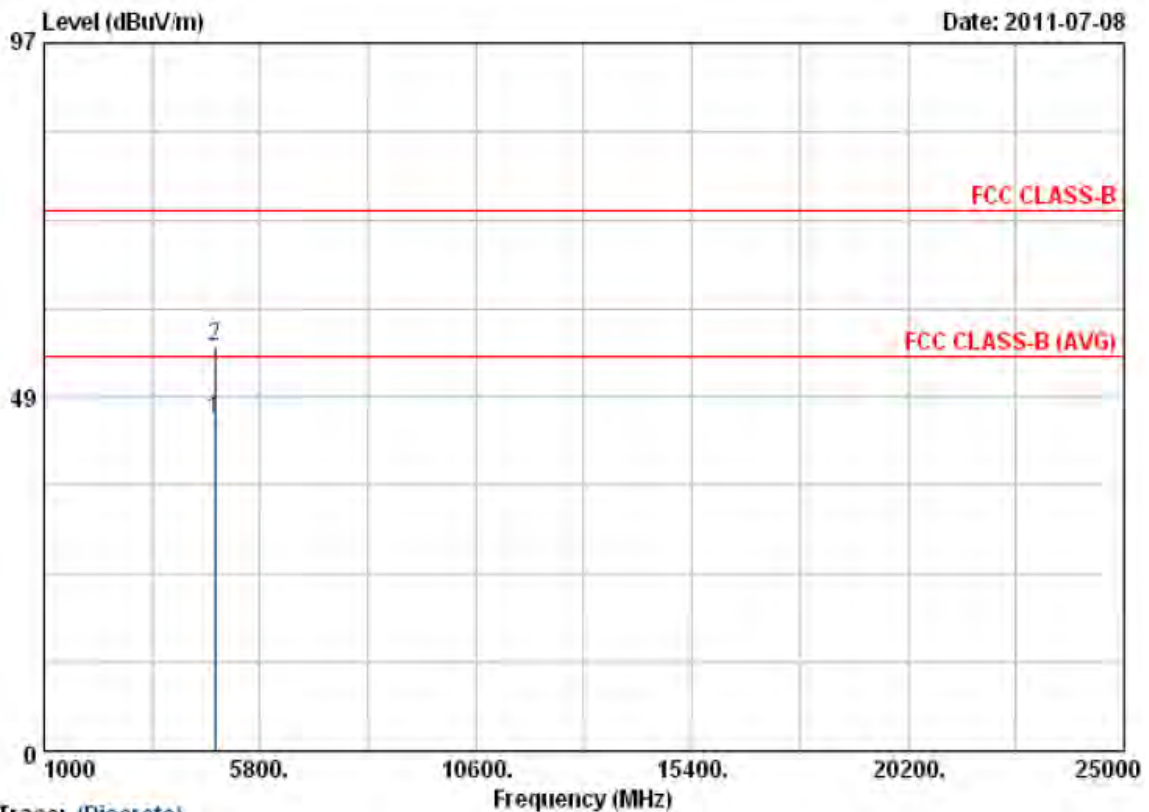

Trace: (Discrete)

Item	Freq	Read Value	Factor	Result	Limit	Margin	Remark	Ant Pos	Tab Pos
	MHz	dBuV	dB/m	dBuV/m	dBuV/m	dB		cm	Deg
1	4804.00	36.60	8.76	45.36	54.00	-8.64	Average	150	250
2	4804.00	46.63	8.76	55.39	74.00	-18.61	Peak	150	250

Notes:

1. Result = Read Value + Factor
2. Factor = Antenna Factor + Cable Loss - Amplifier
3. The resolution bandwidth of test receiver/spectrum analyzer is 120KHz and video bandwidth is 300kHz for Peak detection and Quasi-peak detection at frequency below 1GHz.
4. The resolution bandwidth of test receiver/spectrum analyzer is 1MHz and video bandwidth is 3MHz for Peak detection at frequency above 1GHz.
5. The resolution bandwidth of test receiver/spectrum analyzer is 1MHz and video bandwidth is 10Hz for Average detection at frequency above 1GHz.
6. The other emissions is too low to be measured.
7. The data is worse case.



Power	: AC 120V	Pol/Phase	: VERTICAL
Test Mode	: Transmit / Receive	Temperature	: 25 °C
Operation Channel	: 39	Humidity	: 60 %
Modulation Type	: $\pi/4$ -DQPSK	Atmospheric Pressure	: 1020 hPa
Memo	: Adapter: Touch \ M8-10US05R	Rate	: 2 Mbps

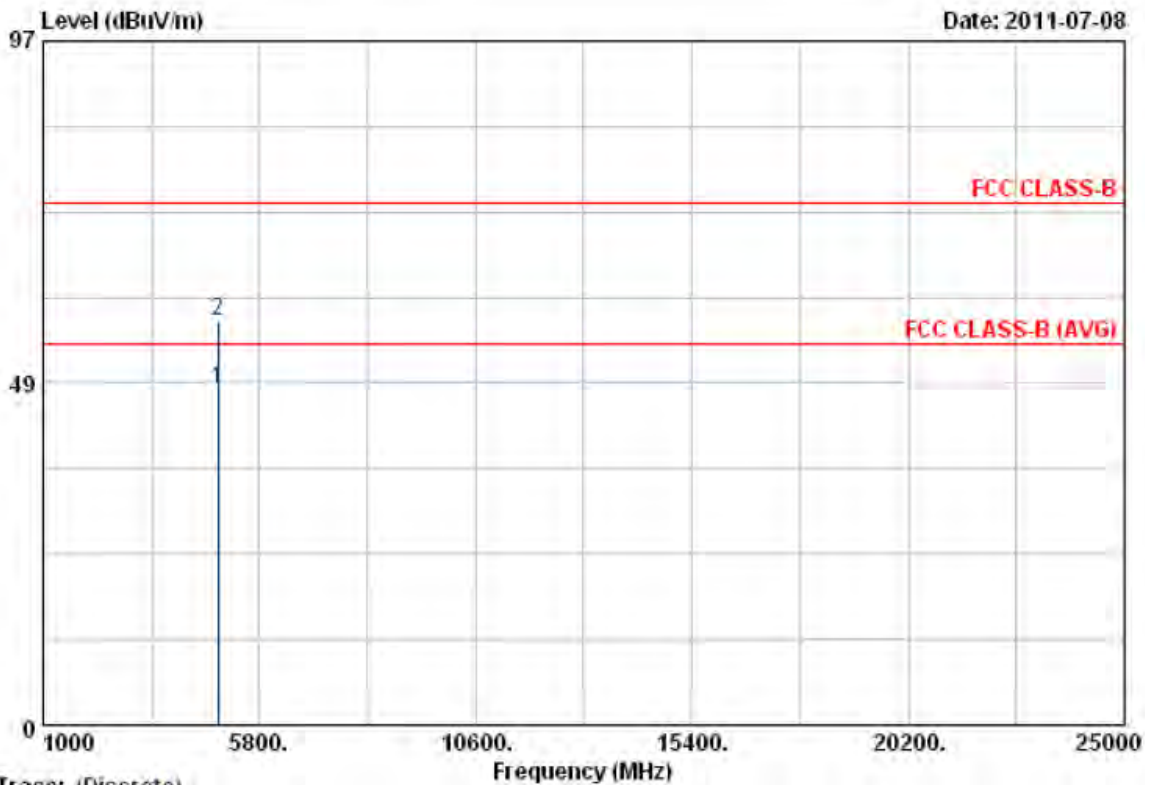

Trace: (Discrete)

Item	Freq	Read Value	Factor	Result	Limit	Margin	Remark	Ant Pos	Tab Pos
	MHz	dBuV	dB/m	dBuV/m	dBuV/m	dB		cm	Deg
1	4882.00	38.57	9.06	47.63	54.00	-6.37	Average	119	240
2	4882.00	48.33	9.06	57.39	74.00	-16.61	Peak	119	240

Notes:

1. Result = Read Value + Factor
2. Factor = Antenna Factor + Cable Loss - Amplifier
3. The resolution bandwidth of test receiver/spectrum analyzer is 120kHz and video bandwidth is 300kHz for Peak detection and Quasi-peak detection at frequency below 1GHz.
4. The resolution bandwidth of test receiver/spectrum analyzer is 1MHz and video bandwidth is 3MHz for Peak detection at frequency above 1GHz.
5. The resolution bandwidth of test receiver/spectrum analyzer is 1MHz and video bandwidth is 10Hz for Average detection at frequency above 1GHz.
6. The other emissions is too low to be measured.
7. The data is worse case.



Power	: AC 120V	Pol/Phase	: HORIZONTAL
Test Mode	: Transmit / Receive	Temperature	: 25 °C
Operation Channel	: 39	Humidity	: 60 %
Modulation Type	: $\pi/4$ -DQPSK	Atmospheric Pressure	: 1020 hPa
Memo	: Adapter: Touch \ M8-10US05R	Rate	: 2 Mbps

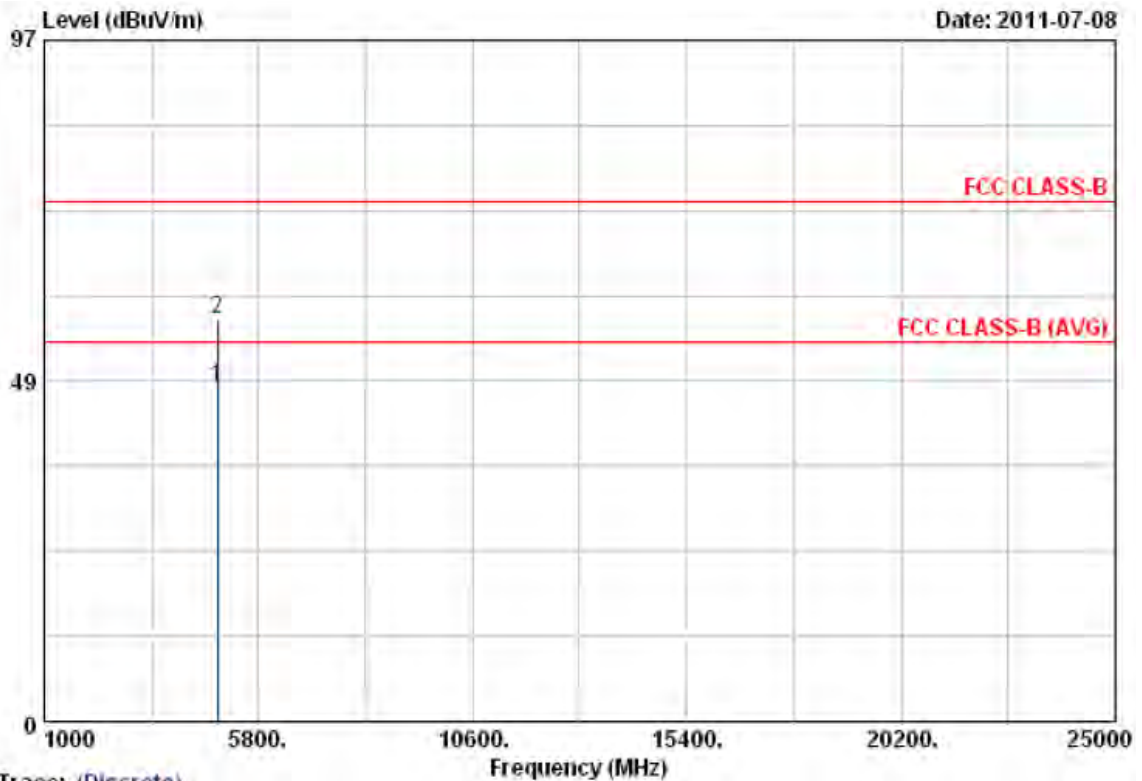

Trace: (Discrete)

Item	Freq	Read Value	Factor	Result	Limit	Margin	Remark	Ant Pos	Tab Pos
	MHz	dBuV	dB/m	dBuV/m	dBuV/m	dB		cm	Deg
1	4882.03	38.57	9.06	47.63	54.00	-6.37	Average	150	250
2	4882.03	48.19	9.06	57.25	74.00	-16.75	Peak	150	250

Notes:

1. Result = Read Value + Factor
2. Factor = Antenna Factor + Cable Loss - Amplifier
3. The resolution bandwidth of test receiver/spectrum analyzer is 120KHz and video bandwidth is 300kHz for Peak detection and Quasi-peak detection at frequency below 1GHz.
4. The resolution bandwidth of test receiver/spectrum analyzer is 1MHz and video bandwidth is 3MHz for Peak detection at frequency above 1GHz.
5. The resolution bandwidth of test receiver/spectrum analyzer is 1MHz and video bandwidth is 10Hz for Average detection at frequency above 1GHz.
6. The other emissions is too low to be measured.
7. The data is worse case.



Power	: AC 120V	Pol/Phase	: VERTICAL
Test Mode	: Transmit / Receive	Temperature	: 25 °C
Operation Channel	: 78	Humidity	: 60 %
Modulation Type	: $\pi/4$ -DQPSK	Atmospheric Pressure	: 1020 hPa
Memo	: Adapter: Touch \ M8-10US05R	Rate	: 2 Mbps

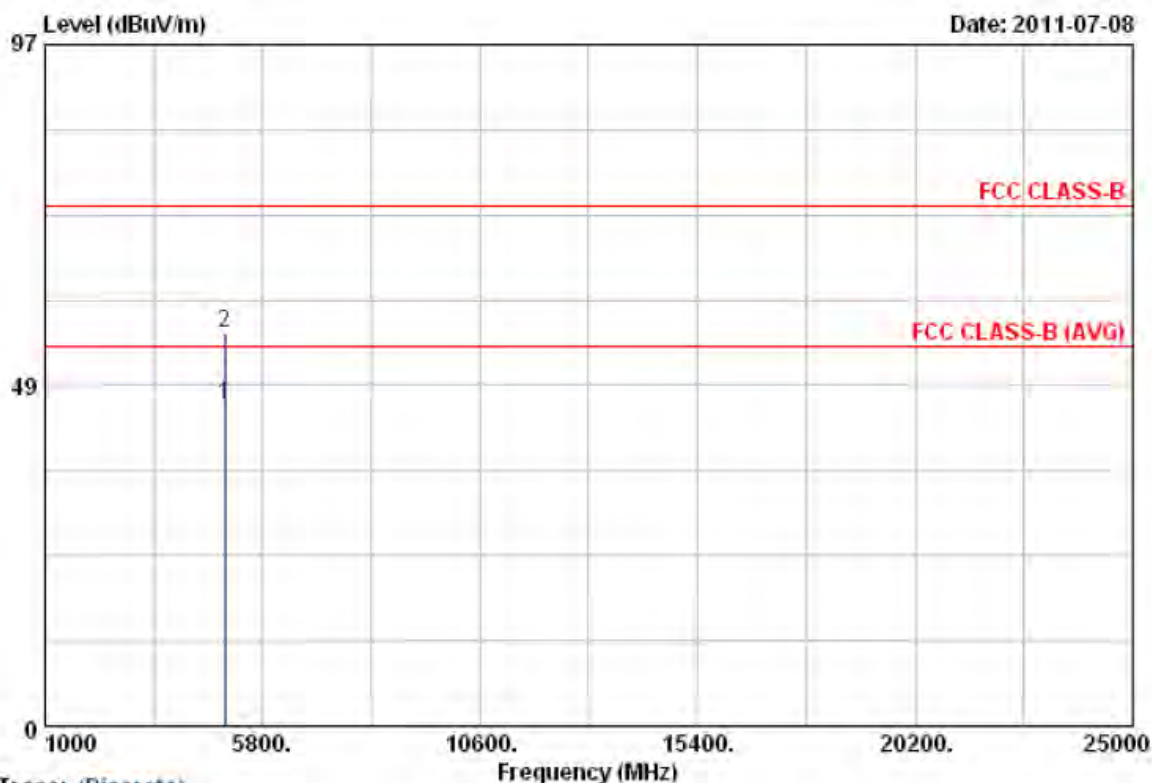

Trace: (Discrete)

Item	Freq	Read Value	Factor	Result	Limit	Margin	Remark	Ant Pos	Tab Pos
	MHz	dBuV	dB/m	dBuV/m	dBuV/m	dB		cm	Deg
1	4960.00	36.37	9.35	45.72	54.00	-8.28	Average	119	240
2	4960.00	46.47	9.35	55.82	74.00	-18.18	Peak	119	240

Notes:

1. Result = Read Value + Factor
2. Factor = Antenna Factor + Cable Loss - Amplifier
3. The resolution bandwidth of test receiver/spectrum analyzer is 120KHz and video bandwidth is 300kHz for Peak detection and Quasi-peak detection at frequency below 1GHz.
4. The resolution bandwidth of test receiver/spectrum analyzer is 1MHz and video bandwidth is 3MHz for Peak detection at frequency above 1GHz.
5. The resolution bandwidth of test receiver/spectrum analyzer is 1MHz and video bandwidth is 10Hz for Average detection at frequency above 1GHz.
6. The other emissions is too low to be measured.
7. The data is worse case.



Power	: AC 120V	Pol/Phase	: HORIZONTAL
Test Mode	: Transmit / Receive	Temperature	: 25 °C
Operation Channel	: 78	Humidity	: 60 %
Modulation Type	: $\pi/4$ -DQPSK	Atmospheric Pressure	: 1020 hPa
Memo	: Adapter: Touch \ M8-10US05R	Rate	: 2 Mbps

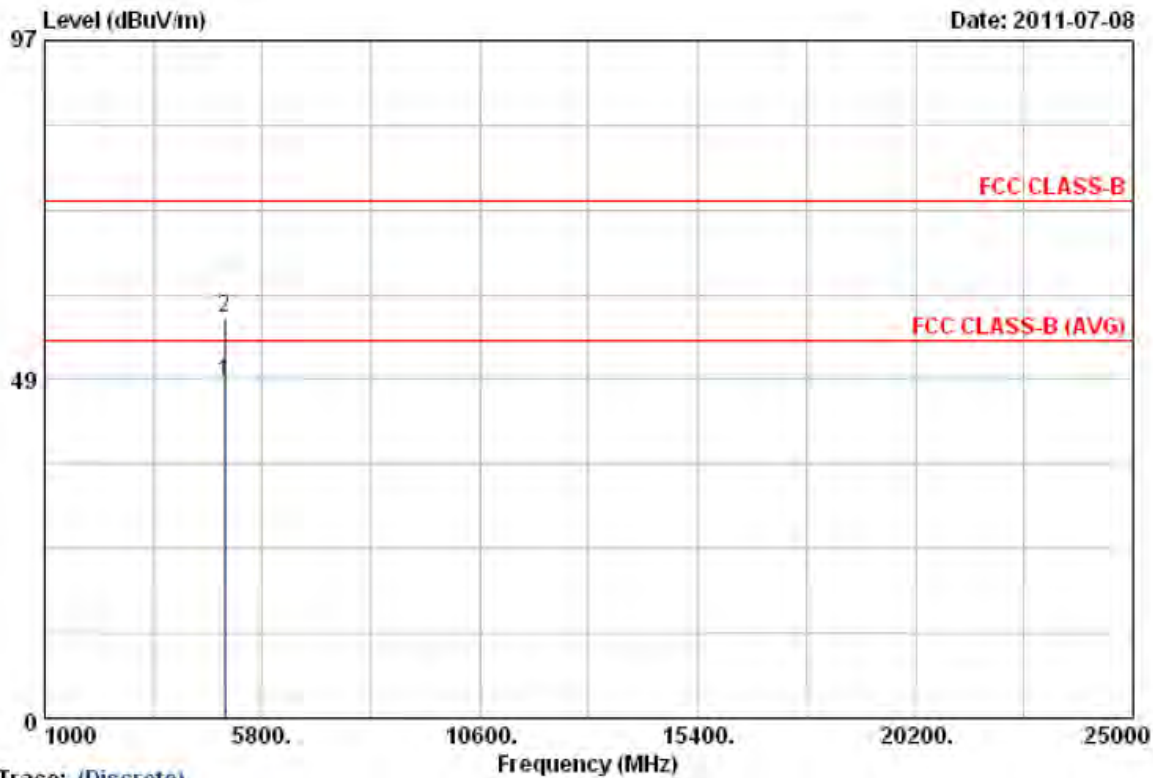

Trace: (Discrete)

Item	Freq	Read Value	Factor	Result	Limit	Margin	Remark	Ant Pos	Tab Pos
	MHz	dBuV	dB/m	dBuV/m	dBuV/m	dB		cm	Deg
1	4959.98	38.67	9.35	48.02	54.00	-5.98	Average	150	250
2	4959.98	48.03	9.35	57.38	74.00	-16.62	Peak	150	250

Notes:

1. Result = Read Value + Factor
2. Factor = Antenna Factor + Cable Loss - Amplifier
3. The resolution bandwidth of test receiver/spectrum analyzer is 120KHz and video bandwidth is 300kHz for Peak detection and Quasi-peak detection at frequency below 1GHz.
4. The resolution bandwidth of test receiver/spectrum analyzer is 1MHz and video bandwidth is 3MHz for Peak detection at frequency above 1GHz.
5. The resolution bandwidth of test receiver/spectrum analyzer is 1MHz and video bandwidth is 10Hz for Average detection at frequency above 1GHz.
6. The other emissions is too low to be measured.
7. The data is worse case.



Power	: AC 120V	Pol/Phase	: VERTICAL
Test Mode	: Transmit / Receive	Temperature	: 23 °C
Operation Channel	: 0	Humidity	: 65 %
Modulation Type	: 8DPSK	Atmospheric Pressure	: 1020 hPa
Memo	: Adapter: Touch \ M8-10US05R	Rate	: 3 Mbps

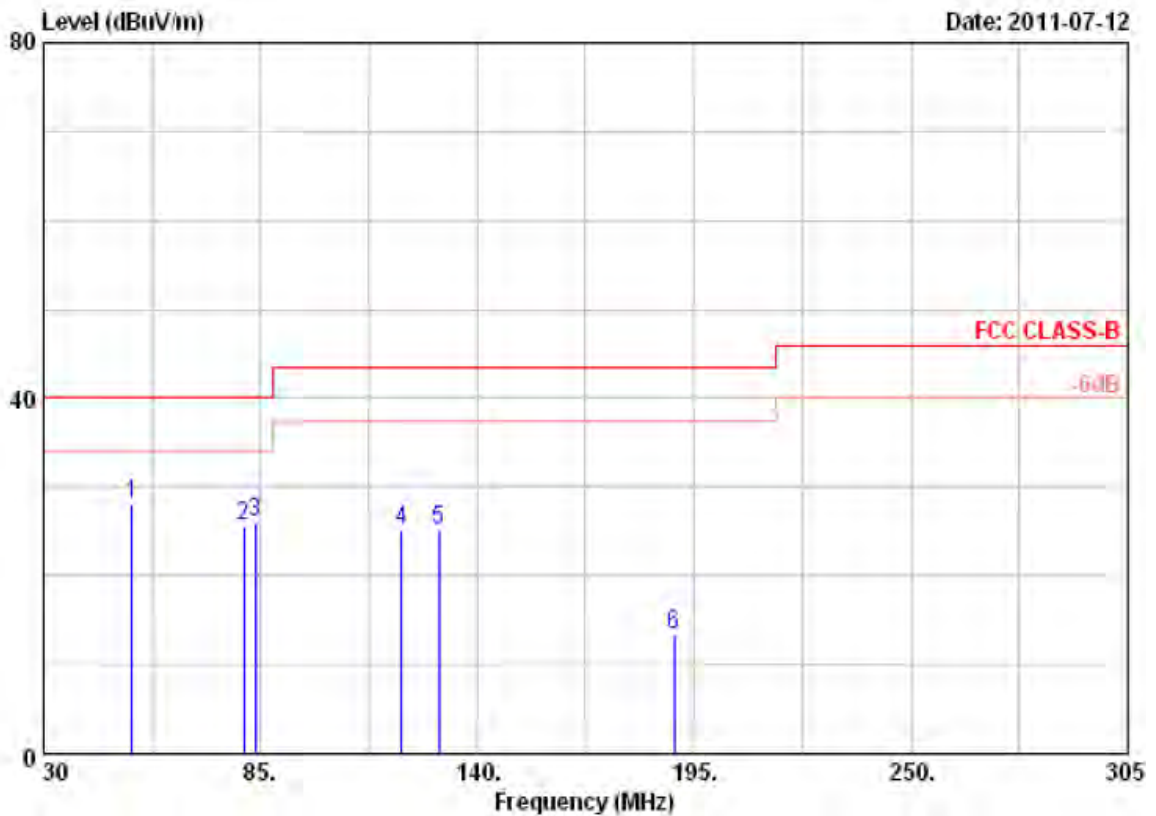

Item	Freq	Read Value	Factor	Result	Limit	Margin	Remark	Ant Pos	Tab Pos
	MHz	dBuV	dB/m	dBuV/m	dBuV/m	dB		cm	Deg
1	52.55	42.48	-14.47	28.01	40.00	-11.99	Peak	100	0
2	80.88	39.62	-13.95	25.67	40.00	-14.33	Peak	100	0
3	83.63	38.98	-12.86	26.12	40.00	-13.88	Peak	100	0
4	120.75	34.67	-9.47	25.20	43.50	-18.30	Peak	100	0
5	130.38	32.68	-7.57	25.11	43.50	-18.39	Peak	100	0
6	190.05	27.15	-13.72	13.43	43.50	-30.07	Peak	100	0

- Remarks:
1. Result = Read Value + Factor
 2. Factor = Antenna Factor + Cable Loss - Amplifier
 3. According to technical experiences, all spurious emission of BT mode at channel 0,39,78 are almost the same below 1GHz, so that the channel 0 was chosen as representative in final test.
 4. The data is worst case.



Power	: AC 120V	Pol/Phase	: VERTICAL
Test Mode	: Transmit / Receive	Temperature	: 23 °C
Operation Channel	: 0	Humidity	: 65 %
Modulation Type	: 8DPSK	Atmospheric Pressure	: 1020 hPa
Memo	: Adapter: Touch \ M8-10US05R	Rate	: 3 Mbps

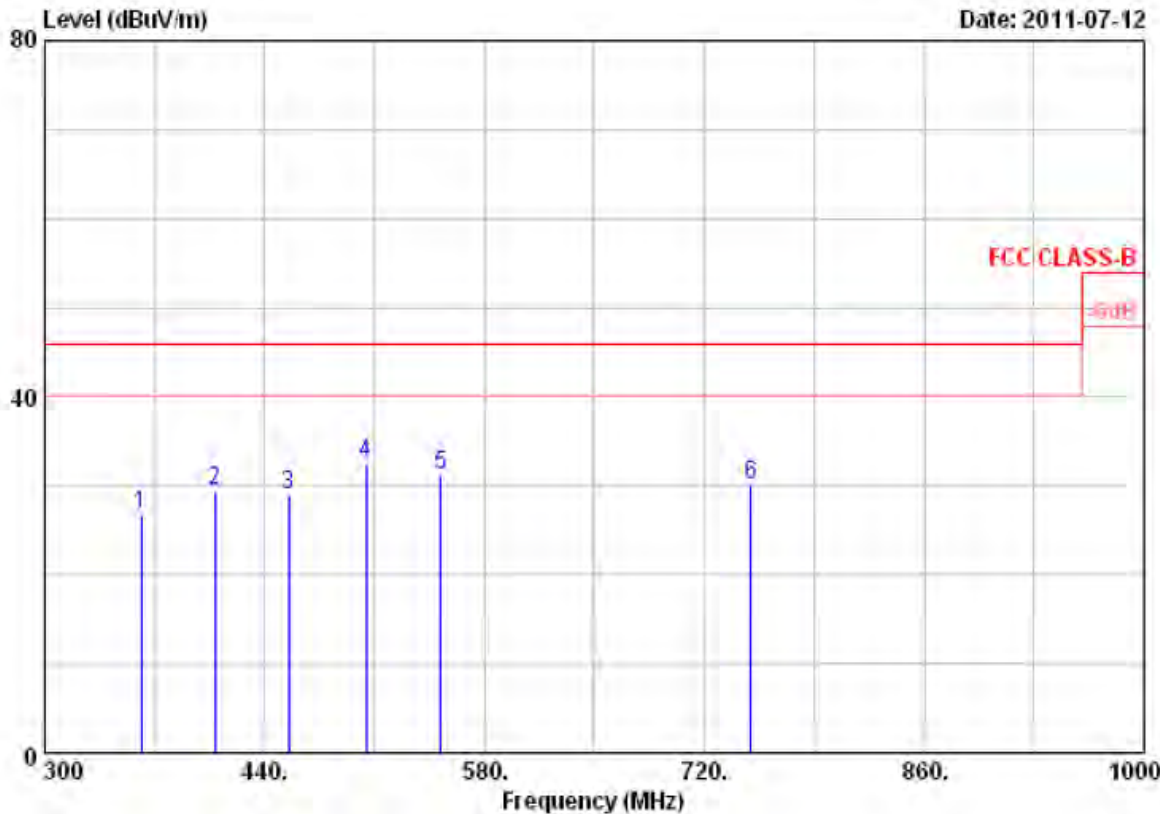

Item	Freq	Read Value	Factor	Result	Limit	Margin	Remark	Ant Pos	Tab Pos
	MHz	dBuV	dB/m	dBuV/m	dBuV/m	dB		cm	Deg
1	361.60	37.81	-11.17	26.64	46.00	-19.36	Peak	100	360
2	408.50	39.55	-10.09	29.46	46.00	-16.54	Peak	100	360
3	455.40	37.66	-8.59	29.07	46.00	-16.93	Peak	100	360
4	504.40	40.90	-8.46	32.44	46.00	-13.56	Peak	100	360
5	552.00	39.49	-8.38	31.11	46.00	-14.89	Peak	100	360
6	749.40	24.99	5.09	30.08	46.00	-15.92	Peak	100	360

- Remarks:
1. Result = Read Value + Factor
 2. Factor = Antenna Factor + Cable Loss - Amplifier
 3. According to technical experiences, all spurious emission of BT mode at channel 0,39,78 are almost the same below 1GHz, so that the channel 0 was chosen as representative in final test.
 4. The data is worst case.



Power	: AC 120V	Pol/Phase	: HORIZONTAL
Test Mode	: Transmit / Receive	Temperature	: 23 °C
Operation Channel	: 0	Humidity	: 65 %
Modulation Type	: 8DPSK	Atmospheric Pressure	: 1020 hPa
Memo	: Adapter: Touch \ M8-10US05R	Rate	: 3 Mbps

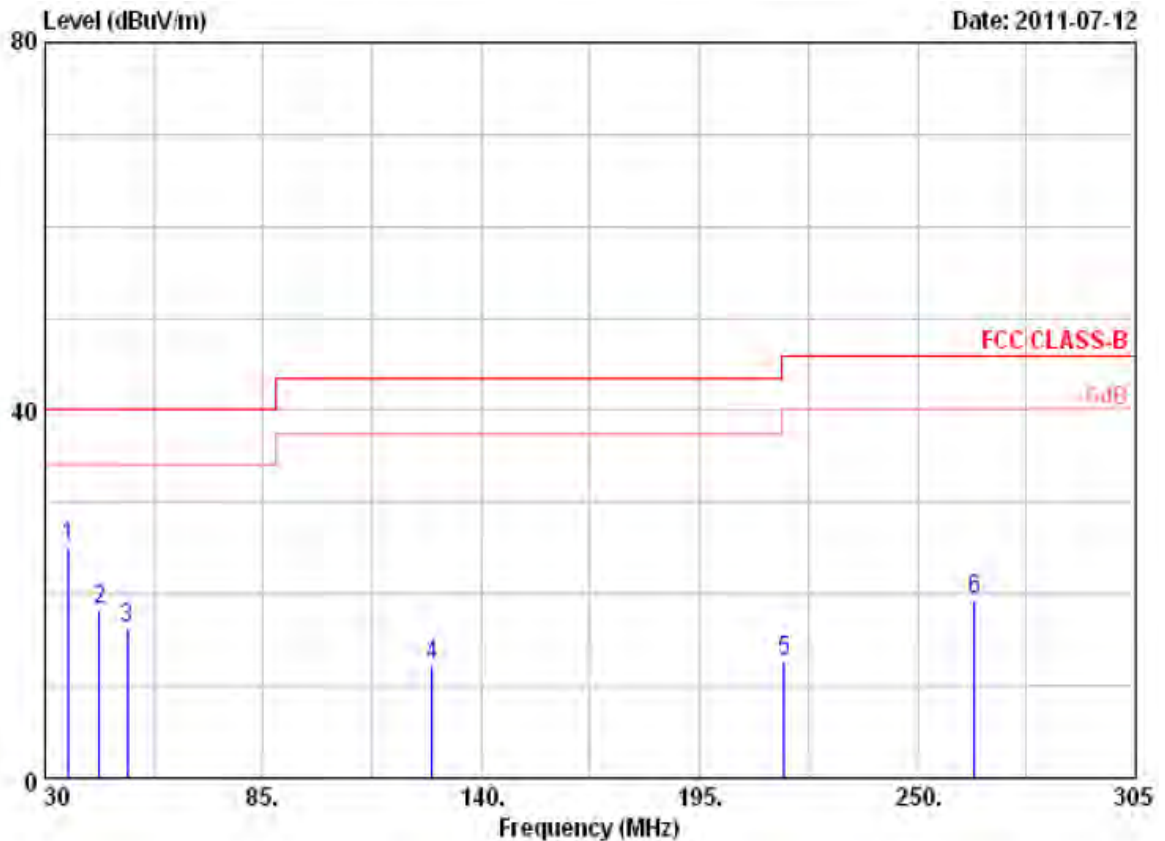

Item	Freq	Read Value	Factor	Result	Limit	Margin	Remark	Ant Pos	Tab Pos
	MHz	dBuV	dB/m	dBuV/m	dBuV/m	dB		cm	Deg
1	36.05	32.99	-7.76	25.23	40.00	-14.77	Peak	100	0
2	43.75	31.98	-13.79	18.19	40.00	-21.81	Peak	100	0
3	50.63	30.44	-14.27	16.17	40.00	-23.83	Peak	100	0
4	127.63	28.23	-16.07	12.16	43.50	-31.34	Peak	100	0
5	216.45	29.30	-16.55	12.75	46.00	-33.25	Peak	100	0
6	264.30	34.46	-15.13	19.33	46.00	-26.67	Peak	100	0

Remarks: 1. Result = Read Value + Factor
 2. Factor = Antenna Factor + Cable Loss - Amplifier
 3. According to technical experiences, all spurious emission of BT mode at channel 0,39,78 are almost the same below 1GHz, so that the channel 0 was chosen as representative in final test.
 4. The data is worst case.



Power	: AC 120V	Pol/Phase	: HORIZONTAL
Test Mode	: Transmit / Receive	Temperature	: 23 °C
Operation Channel	: 0	Humidity	: 65 %
Modulation Type	: 8DPSK	Atmospheric Pressure	: 1020 hPa
Memo	: Adapter: Touch \ M8-10US05R	Rate	: 3 Mbps

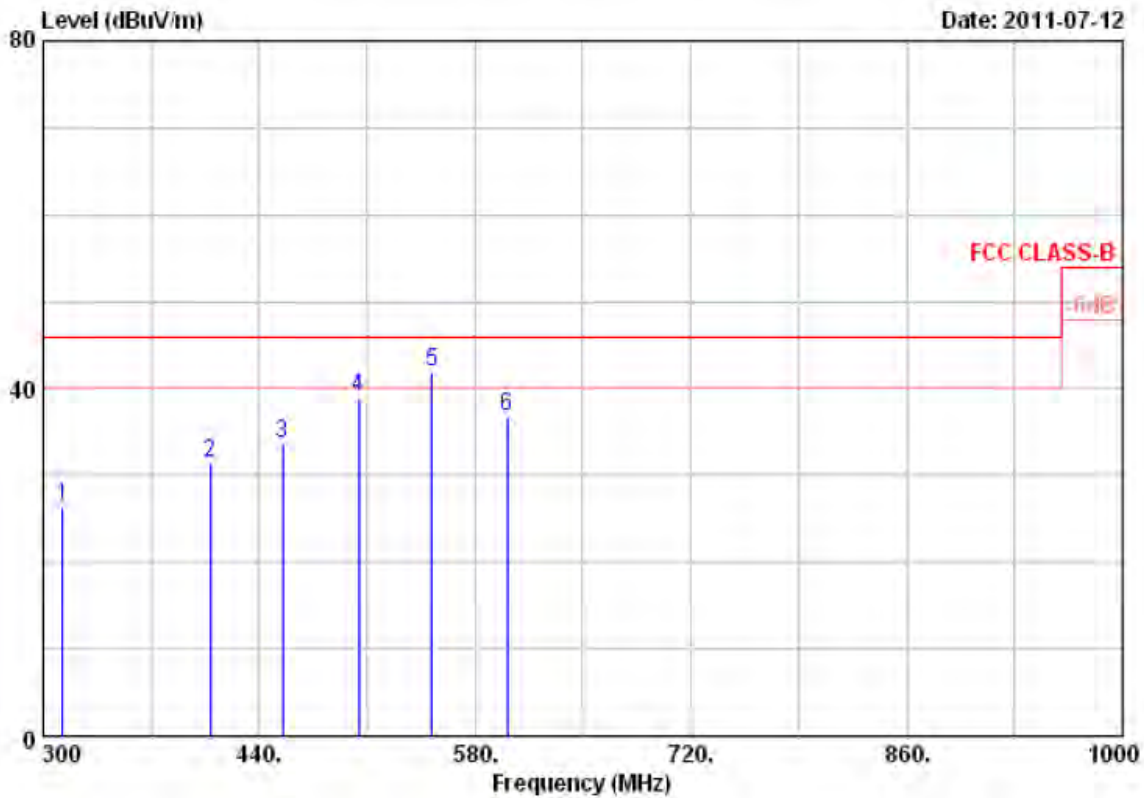

Item	Freq	Read Value	Factor	Result	Limit	Margin	Remark	Ant Pos	Tab Pos
	MHz	dBuV	dB/m	dBuV/m	dBuV/m	dB		cm	Deg
1	312.60	40.45	-14.00	26.45	46.00	-19.55	Peak	100	360
2	408.50	41.75	-10.33	31.42	46.00	-14.58	Peak	100	360
3	455.40	41.99	-8.31	33.68	46.00	-12.32	Peak	100	360
4	504.40	43.57	-4.54	39.03	46.00	-6.97	Peak	100	360
5	552.00	42.55	-0.76	41.79	46.00	-4.21	QP	100	360
6	601.00	36.40	0.42	36.82	46.00	-9.18	Peak	100	360

- Remarks:
1. Result = Read Value + Factor
 2. Factor = Antenna Factor + Cable Loss - Amplifier
 3. According to technical experiences, all spurious emission of BT mode at channel 0,39,78 are almost the same below 1GHz, so that the channel 0 was chosen as representative in final test.
 4. The data is worst case.



Power	: AC 120V	Pol/Phase	: VERTICAL
Test Mode	: Transmit / Receive	Temperature	: 25 °C
Operation Channel	: 0	Humidity	: 60 %
Modulation Type	: 8DPSK	Atmospheric Pressure	: 1020 hPa
Memo	: Adapter: Touch \ M8-10US05R	Rate	: 3 Mbps

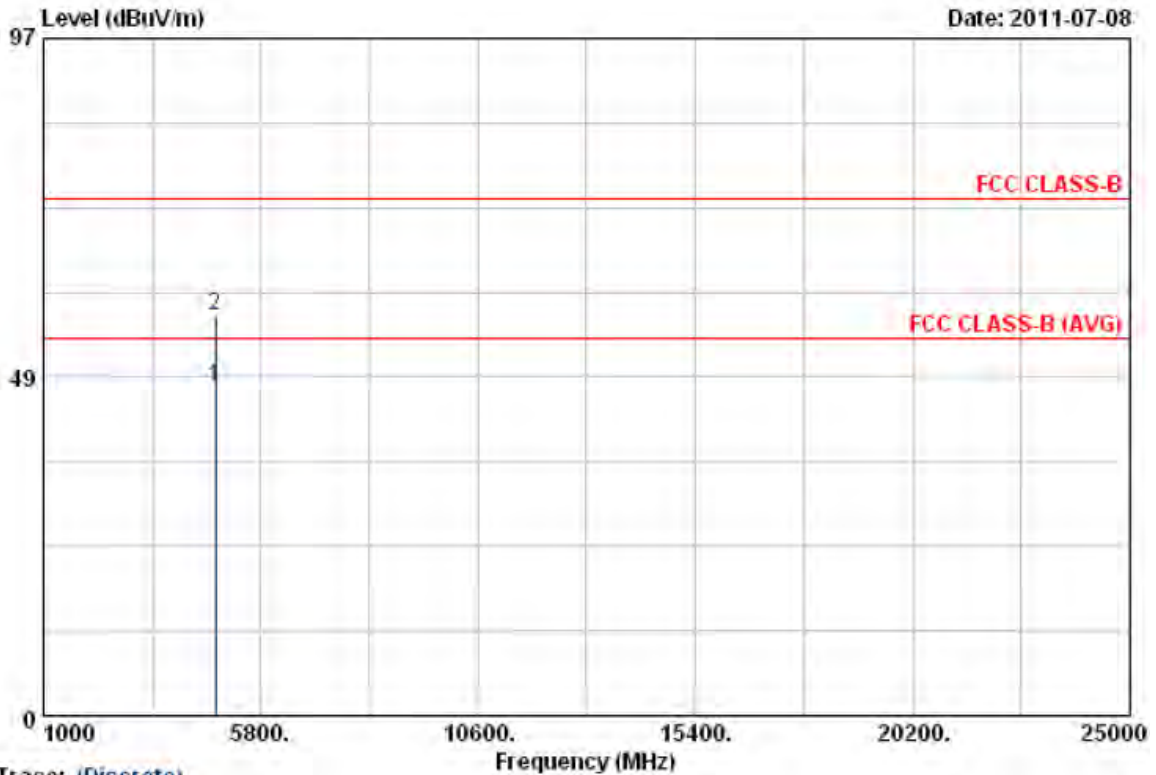

Trace: (Discrete)

Item	Freq	Read Value	Factor	Result	Limit	Margin	Remark	Ant Pos	Tab Pos
	MHz	dBuV	dB/m	dBuV/m	dBuV/m	dB		cm	Deg
1	4804.00	38.37	8.76	47.13	54.00	-6.87	Average	119	240
2	4804.00	48.62	8.76	57.38	74.00	-16.62	Peak	119	240

Notes:

1. Result = Read Value + Factor
2. Factor = Antenna Factor + Cable Loss - Amplifier
3. The resolution bandwidth of test receiver/spectrum analyzer is 120KHz and video bandwidth is 300kHz for Peak detection and Quasi-peak detection at frequency below 1GHz.
4. The resolution bandwidth of test receiver/spectrum analyzer is 1MHz and video bandwidth is 3MHz for Peak detection at frequency above 1GHz.
5. The resolution bandwidth of test receiver/spectrum analyzer is 1MHz and video bandwidth is 10Hz for Average detection at frequency above 1GHz.
6. The other emissions is too low to be measured.
7. The data is worse case.



Power	: AC 120V	Pol/Phase	: HORIZONTAL
Test Mode	: Transmit / Receive	Temperature	: 25 °C
Operation Channel	: 0	Humidity	: 60 %
Modulation Type	: 8DPSK	Atmospheric Pressure	: 1020 hPa
Memo	: Adapter: Touch \ M8-10US05R	Rate	: 3 Mbps

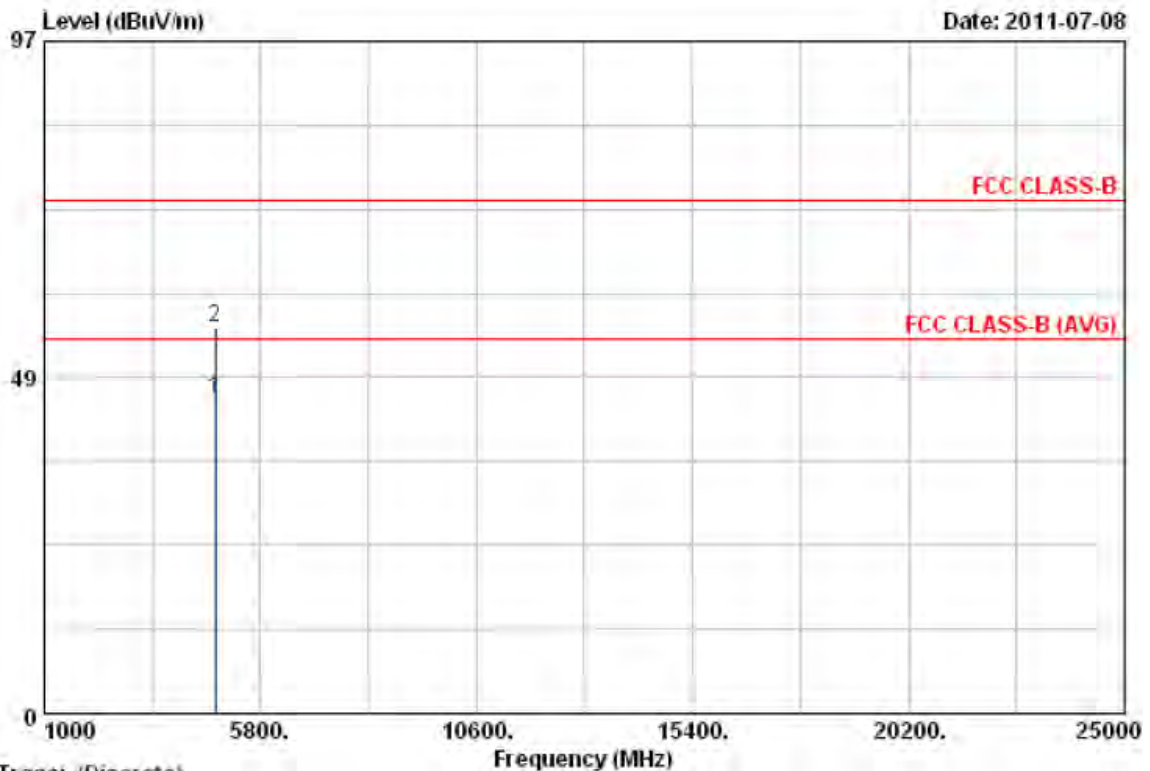

Trace: (Discrete)

Item	Freq	Read Value	Factor	Result	Limit	Margin	Remark	Ant Pos	Tab Pos
	MHz	dBuV	dB/m	dBuV/m	dBuV/m	dB		cm	Deg
1	4804.00	36.68	8.76	45.44	54.00	-8.56	Average	150	250
2	4804.00	46.91	8.76	55.67	74.00	-18.33	Peak	150	250

Notes:

1. Result = Read Value + Factor
2. Factor = Antenna Factor + Cable Loss - Amplifier
3. The resolution bandwidth of test receiver/spectrum analyzer is 120KHz and video bandwidth is 300kHz for Peak detection and Quasi-peak detection at frequency below 1GHz.
4. The resolution bandwidth of test receiver/spectrum analyzer is 1MHz and video bandwidth is 3MHz for Peak detection at frequency above 1GHz.
5. The resolution bandwidth of test receiver/spectrum analyzer is 1MHz and video bandwidth is 10Hz for Average detection at frequency above 1GHz.
6. The other emissions is too low to be measured.
7. The data is worse case.



Power	: AC 120V	Pol/Phase	: VERTICAL
Test Mode	: Transmit / Receive	Temperature	: 25 °C
Operation Channel	: 39	Humidity	: 60 %
Modulation Type	: 8DPSK	Atmospheric Pressure	: 1020 hPa
Memo	: Adapter: Touch \ M8-10US05R	Rate	: 3 Mbps

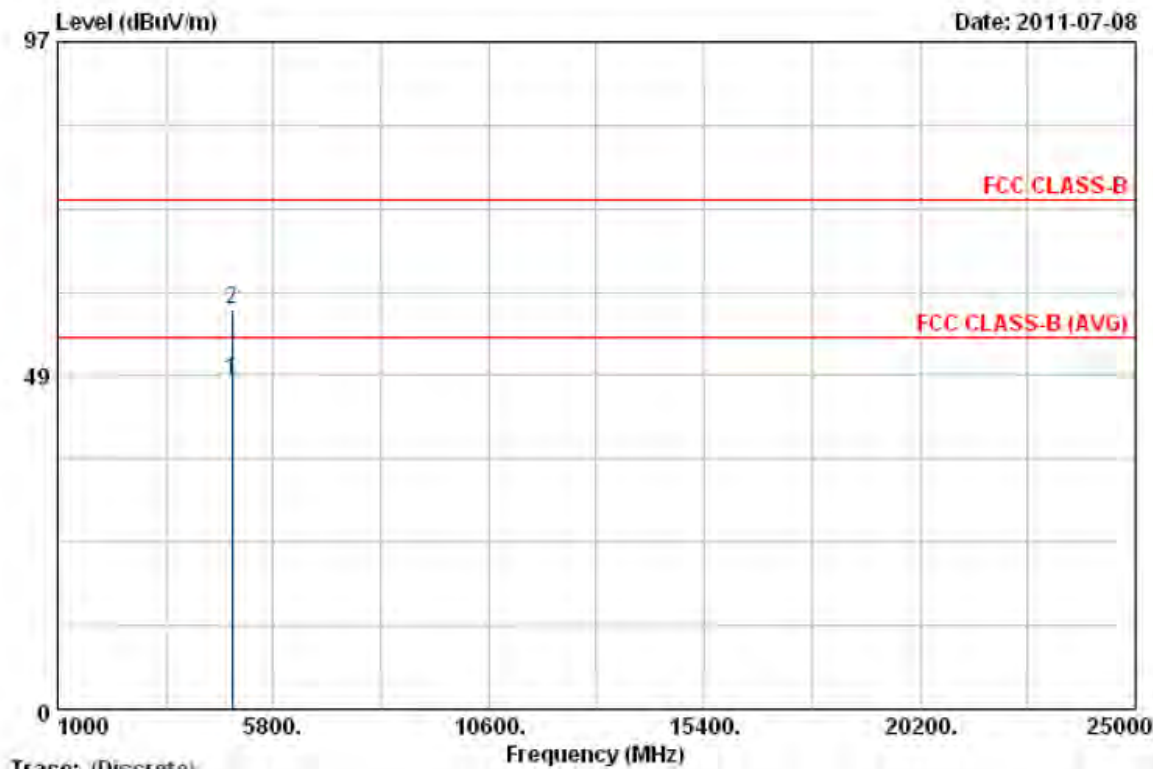

Trace: (Discrete)

Item	Freq	Read Value	Factor	Result	Limit	Margin	Remark	Ant Pos	Tab Pos
	MHz	dBuV	dB/m	dBuV/m	dBuV/m	dB		cm	Deg
1	4881.98	38.87	9.06	47.93	54.00	-6.07	Average	119	240
2	4881.98	48.98	9.06	58.04	74.00	-15.96	Peak	119	240

Notes:

1. Result = Read Value + Factor
2. Factor = Antenna Factor + Cable Loss - Amplifier
3. The resolution bandwidth of test receiver/spectrum analyzer is 120KHz and video bandwidth is 300kHz for Peak detection and Quasi-peak detection at frequency below 1GHz.
4. The resolution bandwidth of test receiver/spectrum analyzer is 1MHz and video bandwidth is 3MHz for Peak detection at frequency above 1GHz.
5. The resolution bandwidth of test receiver/spectrum analyzer is 1MHz and video bandwidth is 10Hz for Average detection at frequency above 1GHz.
6. The other emissions is too low to be measured.
7. The data is worse case.



Power	: AC 120V	Pol/Phase	: HORIZONTAL
Test Mode	: Transmit / Receive	Temperature	: 25 °C
Operation Channel	: 39	Humidity	: 60 %
Modulation Type	: 8DPSK	Atmospheric Pressure	: 1020 hPa
Memo	: Adapter: Touch \ M8-10US05R	Rate	: 3 Mbps

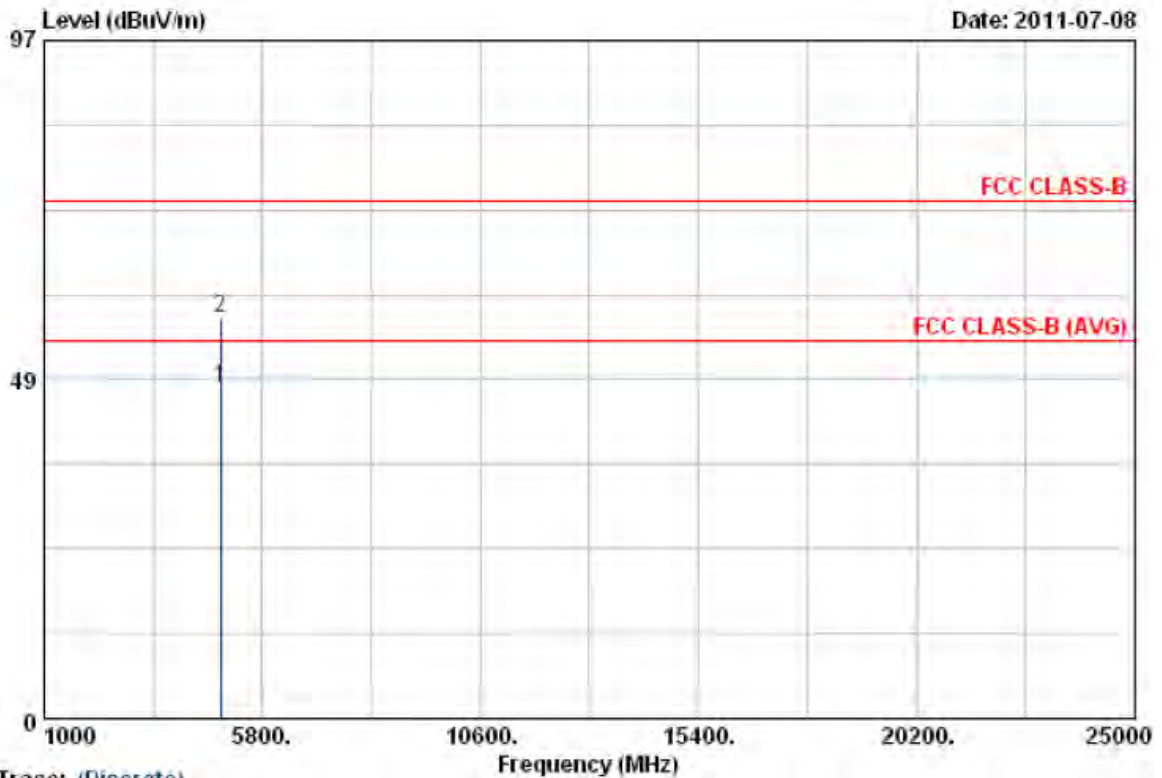

Trace: (Discrete)

Item	Freq	Read Value	Factor	Result	Limit	Margin	Remark	Ant Pos	Tab Pos
	MHz	dBuV	dB/m	dBuV/m	dBuV/m	dB		cm	Deg
1	4882.00	38.17	9.06	47.23	54.00	-6.77	Average	150	250
2	4882.00	48.25	9.06	57.31	74.00	-16.69	Peak	150	250

Notes:

1. Result = Read Value + Factor
2. Factor = Antenna Factor + Cable Loss - Amplifier
3. The resolution bandwidth of test receiver/spectrum analyzer is 120KHz and video bandwidth is 300kHz for Peak detection and Quasi-peak detection at frequency below 1GHz.
4. The resolution bandwidth of test receiver/spectrum analyzer is 1MHz and video bandwidth is 3MHz for Peak detection at frequency above 1GHz.
5. The resolution bandwidth of test receiver/spectrum analyzer is 1MHz and video bandwidth is 10Hz for Average detection at frequency above 1GHz.
6. The other emissions is too low to be measured.
7. The data is worse case.



Power	: AC 120V	Pol/Phase	: VERTICAL
Test Mode	: Transmit / Receive	Temperature	: 25 °C
Operation Channel	: 78	Humidity	: 60 %
Modulation Type	: 8DPSK	Atmospheric Pressure	: 1020 hPa
Memo	: Adapter: Touch \ M8-10US05R	Rate	: 3 Mbps

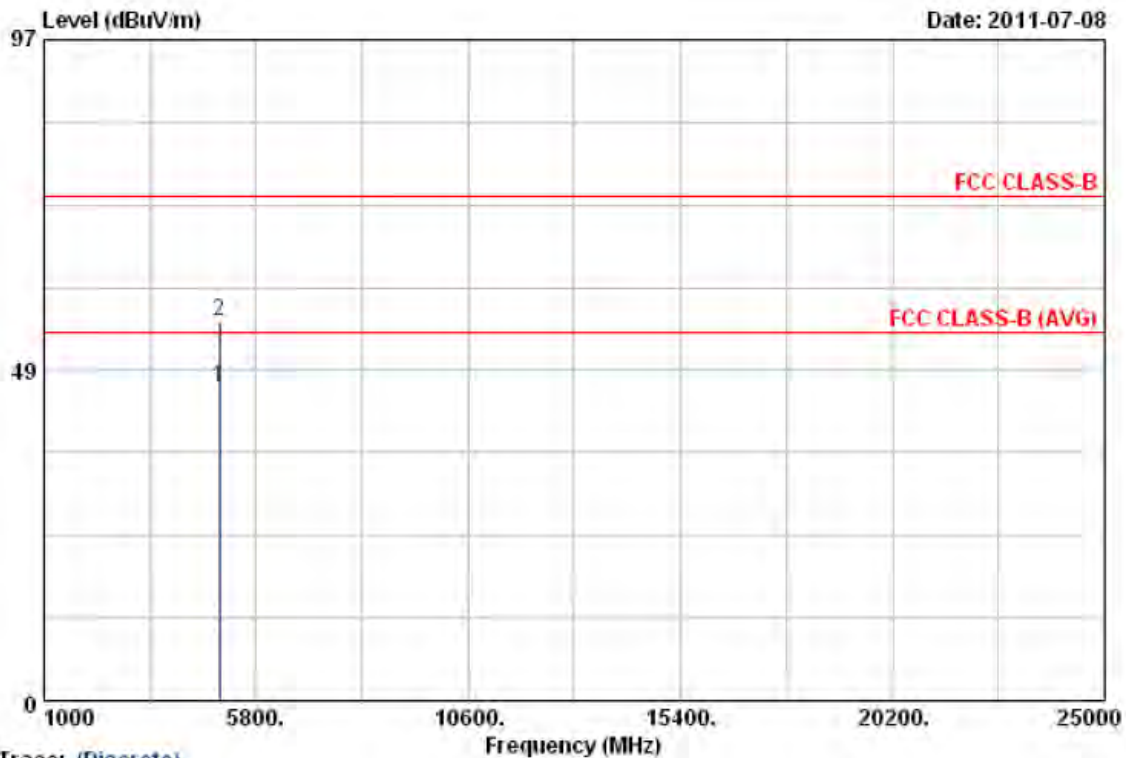

Trace: (Discrete)

Item	Freq	Read Value	Factor	Result	Limit	Margin	Remark	Ant Pos	Tab Pos
	MHz	dBuV	dB/m	dBuV/m	dBuV/m	dB		cm	Deg
1	4960.00	36.67	9.35	46.02	54.00	-7.98	Average	119	240
2	4960.00	46.39	9.35	55.74	74.00	-18.26	Peak	119	240

Notes:

1. Result = Read Value + Factor
2. Factor = Antenna Factor + Cable Loss - Amplifier
3. The resolution bandwidth of test receiver/spectrum analyzer is 120KHz and video bandwidth is 300kHz for Peak detection and Quasi-peak detection at frequency below 1GHz.
4. The resolution bandwidth of test receiver/spectrum analyzer is 1MHz and video bandwidth is 3MHz for Peak detection at frequency above 1GHz.
5. The resolution bandwidth of test receiver/spectrum analyzer is 1MHz and video bandwidth is 10Hz for Average detection at frequency above 1GHz.
6. The other emissions is too low to be measured.
7. The data is worse case.



Power	: AC 120V	Pol/Phase	: VERTICAL
Test Mode	: Transmit / Receive	Temperature	: 25 °C
Operation Channel	: 78	Humidity	: 60 %
Modulation Type	: 8DPSK	Atmospheric Pressure	: 1020 hPa
Memo	: Adapter: Touch \ M8-10US05R	Rate	: 3 Mbps

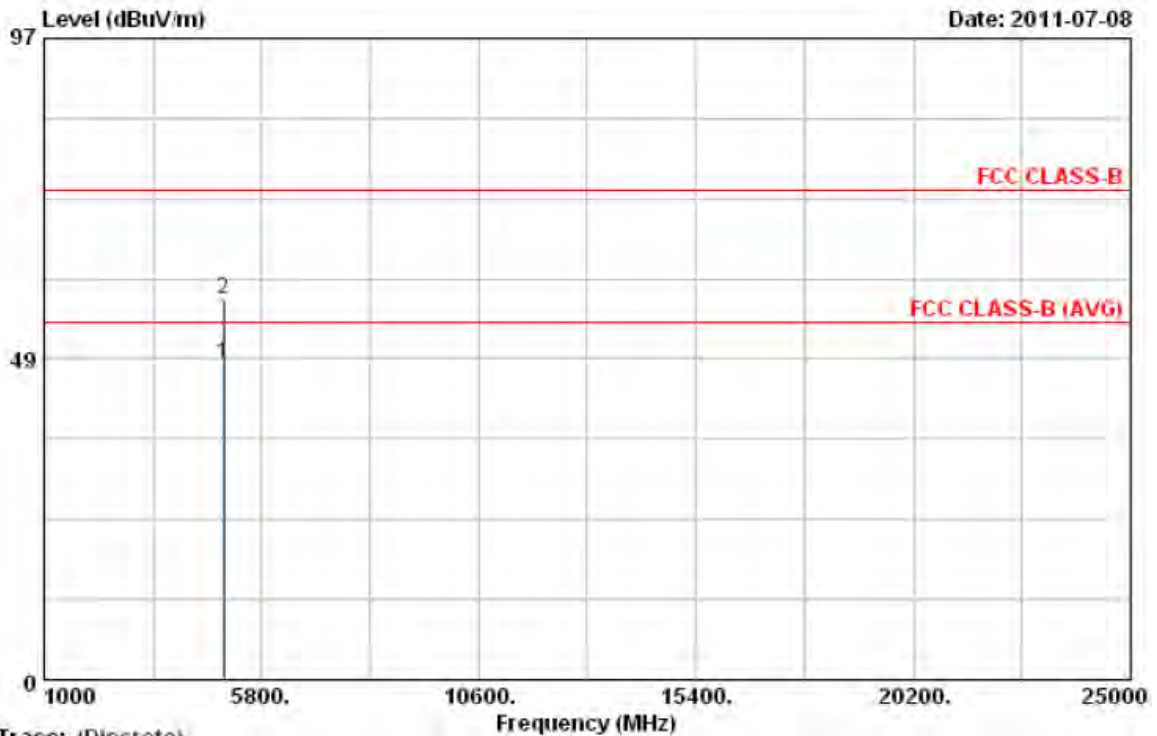

Trace: (Discrete)

Item	Freq	Read Value	Factor	Result	Limit	Margin	Remark	Ant Pos	Tab Pos
	MHz	dBuV	dB/m	dBuV/m	dBuV/m	dB		cm	Deg
1	4960.03	38.57	9.35	47.92	54.00	-6.08	Average	150	250
2	4960.03	48.07	9.35	57.42	74.00	-16.58	Peak	150	250

Notes:

1. Result = Read Value + Factor
2. Factor = Antenna Factor + Cable Loss - Amplifier
3. The resolution bandwidth of test receiver/spectrum analyzer is 120KHz and video bandwidth is 300KHz for Peak detection and Quasi-peak detection at frequency below 1GHz.
4. The resolution bandwidth of test receiver/spectrum analyzer is 1MHz and video bandwidth is 3MHz for Peak detection at frequency above 1GHz.
5. The resolution bandwidth of test receiver/spectrum analyzer is 1MHz and video bandwidth is 10Hz for Average detection at frequency above 1GHz.
6. The other emissions is too low to be measured.
7. The data is worse case.

Test engineer: Ben



6. 20dB Bandwidth Measurement Data

6.1 Test Limit

Frequency hopping systems shall have hopping channel carrier frequencies separated by a minimum of 25 kHz or the 20 dB bandwidth of the hopping channel, whichever is greater. Alternatively, frequency hopping systems operating in the 2400–2483.5 MHz band may have hopping channel carrier frequencies that are separated by 25 kHz or two-thirds of the 20 dB bandwidth of the hopping channel, whichever is greater, provided the systems operate with an output power no greater than 125 mW.

6.2 Test Procedures

- a. The transmitter output was connected to the spectrum analyzer.
- b. Set RBW of spectrum analyzer to 30 KHz and VBW to 100 KHz.
- c. The 20 dB bandwidth is defined as the total spectrum the power of which is higher than peak power minus 20 dB.

6.3 Test Setup Layout

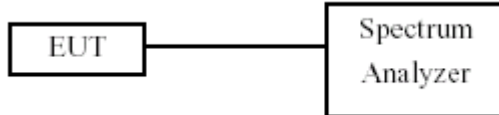

6.4 Measurement equipment

Instrument/Ancillary	Model No.	Manufacturer	Serial No.	Calibration Date	Valid Date
Spectrum Analyzer	R&S	FSP40	100047	2011/05/05	2012/05/04



6.5 Test Result and Data

Modulation Standard: GFSK (1Mbps)

Test Date: Jul. 06, 2011

Temperature: 25

Atmospheric pressure: 1020 hPa

Humidity: 65%

Channel	Frequency (MHz)	20dB Bandwidth (KHz)
00	2402	796.00
39	2441	800.00
78	2480	796.00

Modulation Standard: $\pi/4$ -DQPSK (2Mbps)

Test Date: Jul. 06, 2011

Temperature: 25

Atmospheric pressure: 1020 hPa

Humidity: 65%

Channel	Frequency (MHz)	20dB Bandwidth (KHz)
00	2402	1294.00
39	2441	1222.00
78	2480	1250.00

Modulation Standard: 8DPSK (3Mbps)

Test Date: Jul. 06, 2011

Temperature: 25

Atmospheric pressure: 1020 hPa

Humidity: 65%

Channel	Frequency (MHz)	20dB Bandwidth (KHz)
00	2402	1264.00
39	2441	1272.00
78	2480	1260.00



Modulation Standard: GFSK (1Mbps)
Channel: 00

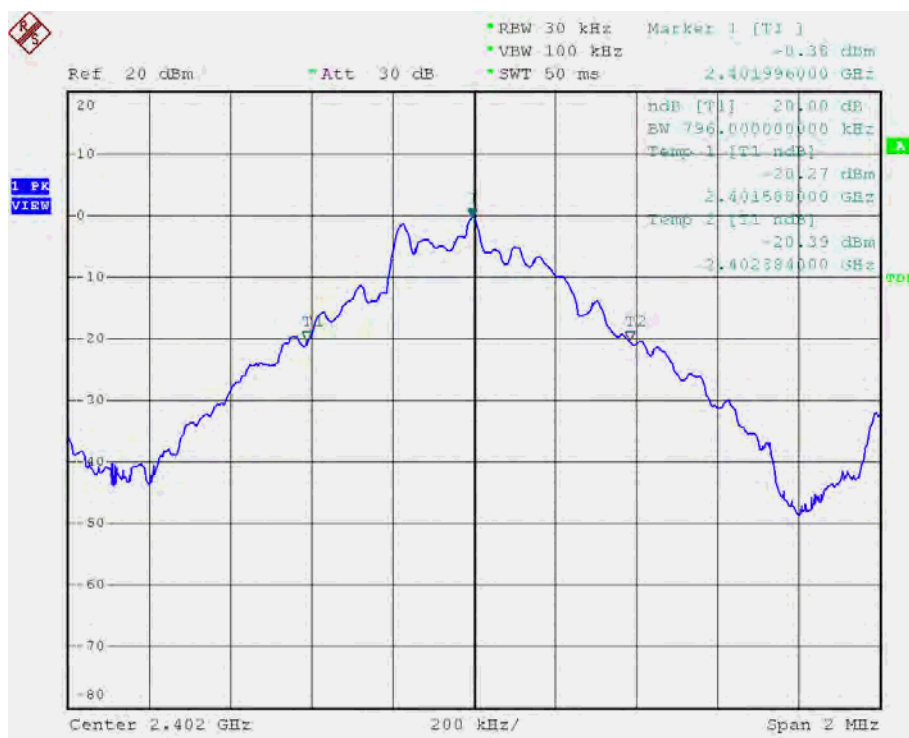

Modulation Standard: GFSK (1Mbps)
Channel: 39

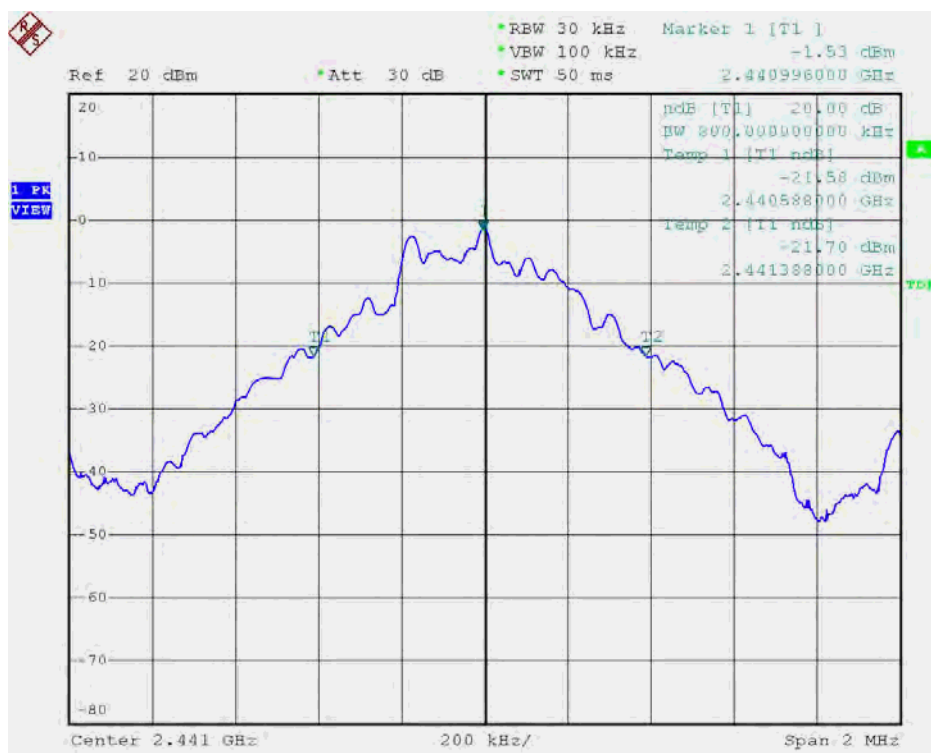



Modulation Standard: GFSK (1Mbps)
Channel: 78

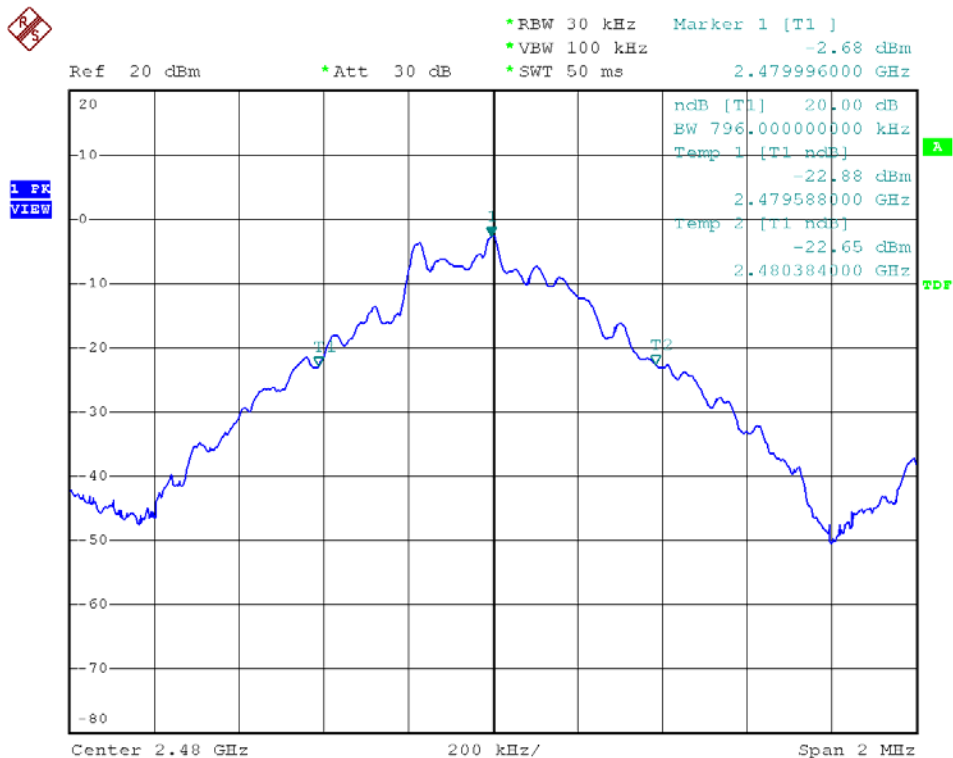

Modulation Standard: $\pi/4$ -DQPSK (2Mbps)
Channel: 00

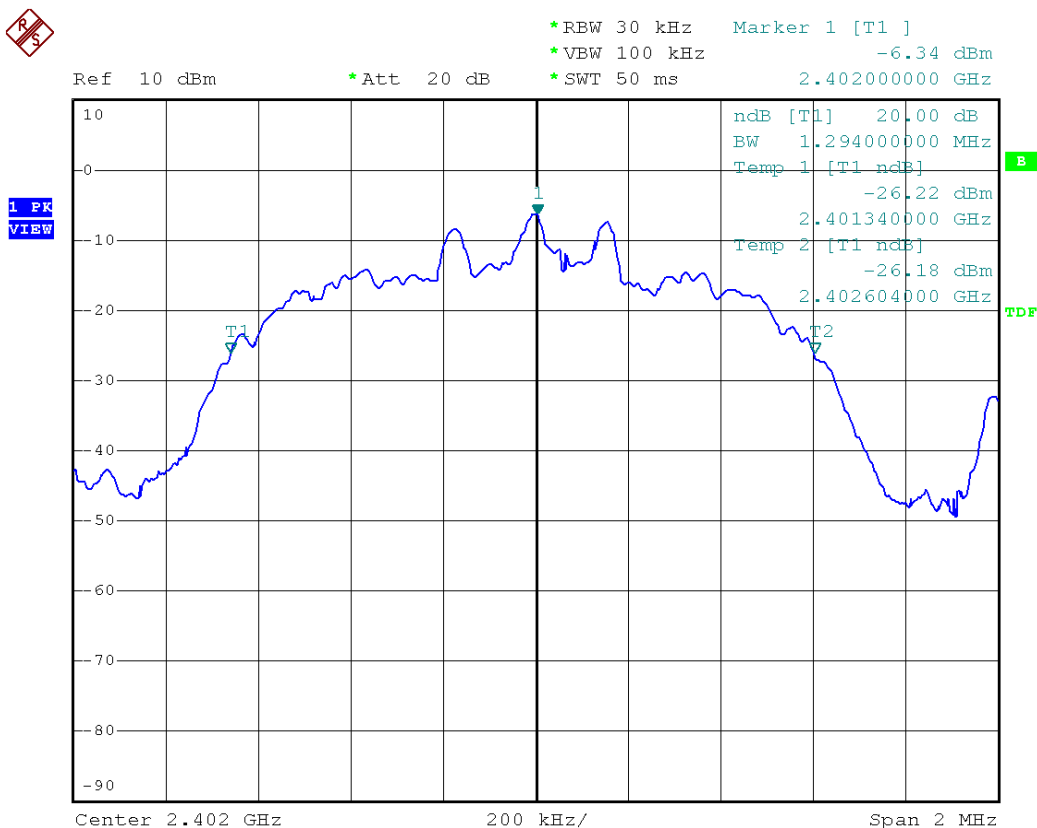



Modulation Standard: $\pi/4$ -DQPSK (2Mbps)
Channel: 39

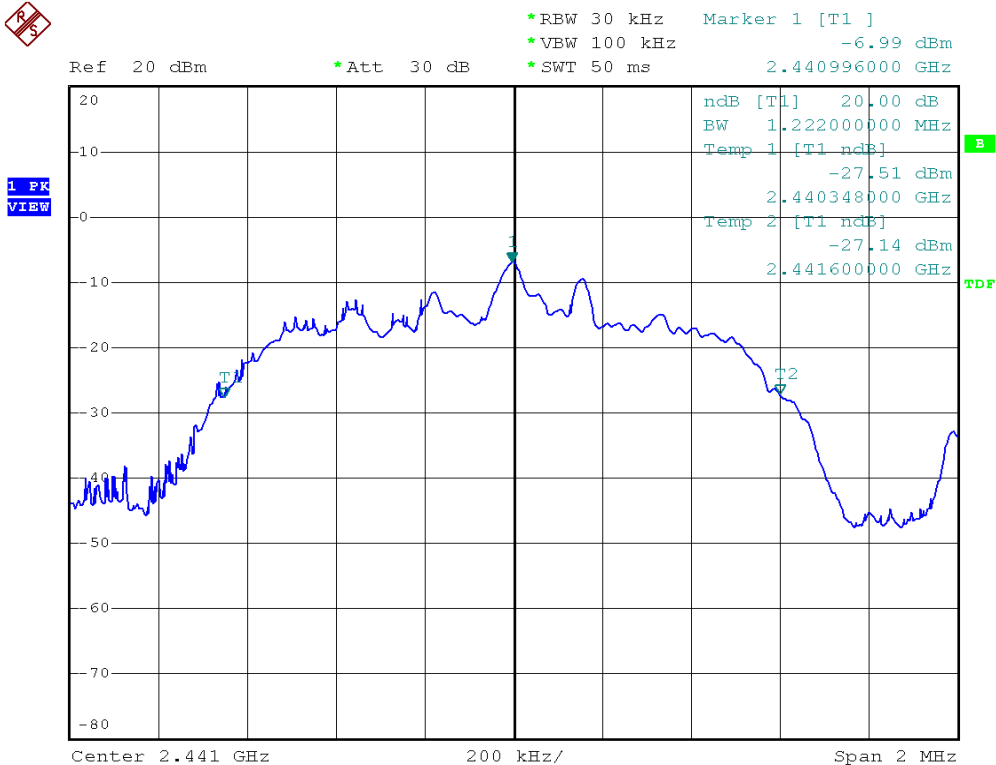

Modulation Standard: $\pi/4$ -DQPSK (2Mbps)
Channel: 78

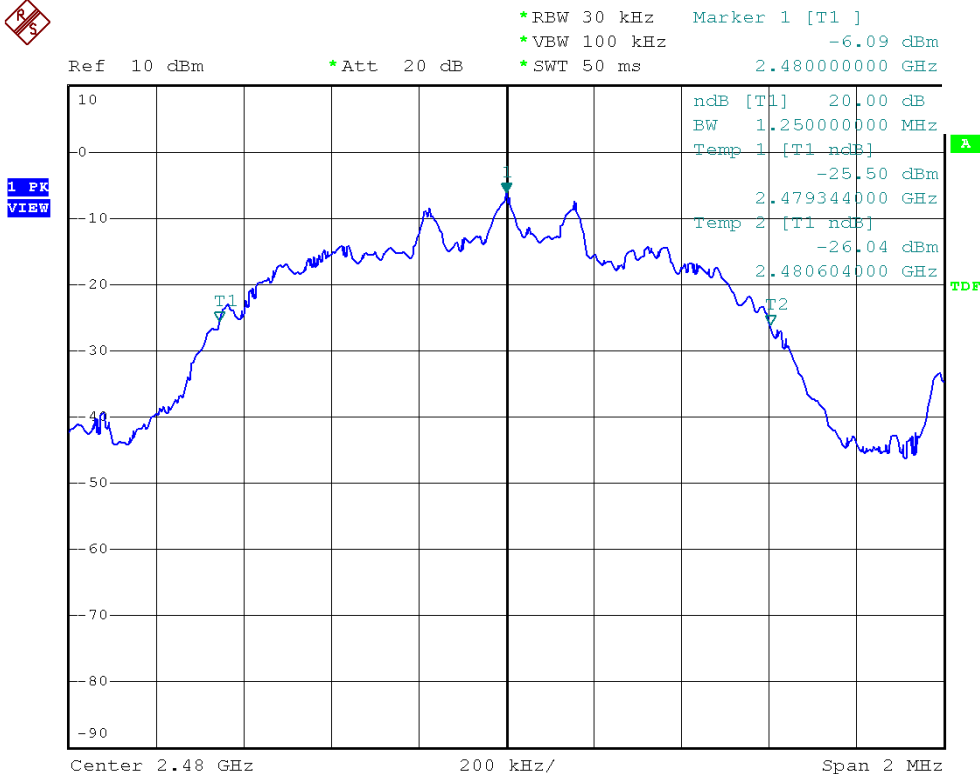



Modulation Standard: 8DPSK (3Mbps)
Channel: 00

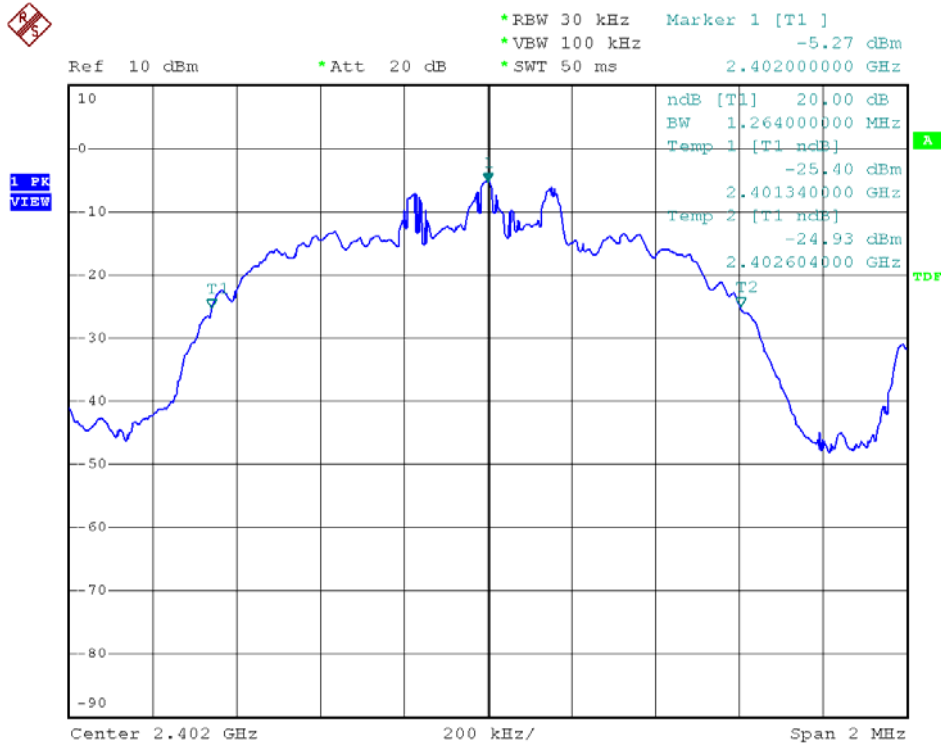

Modulation Standard: 8DPSK (3Mbps)
Channel: 39

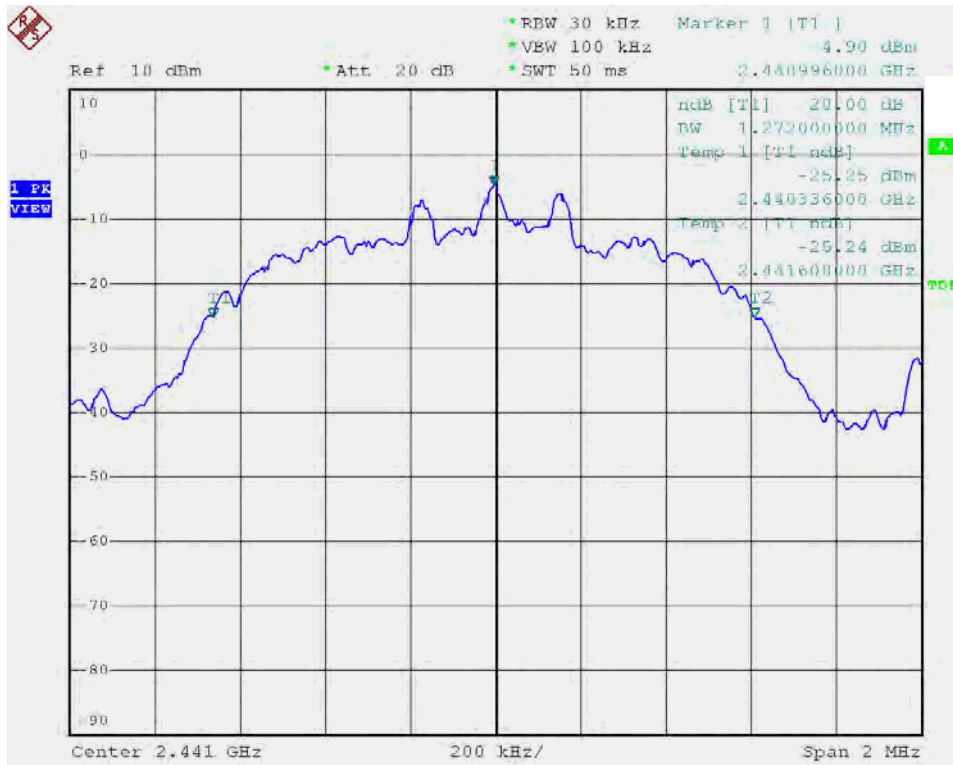



Modulation Standard: 8DPSK (3Mbps)
Channel: 78



*RBW 30 kHz Marker 1 [T1]
*VBW 100 kHz -6.09 dBm
*SWT 50 ms 2.480000000 GHz

Ref 10 dBm

*Att 20 dB

PK
VIEW

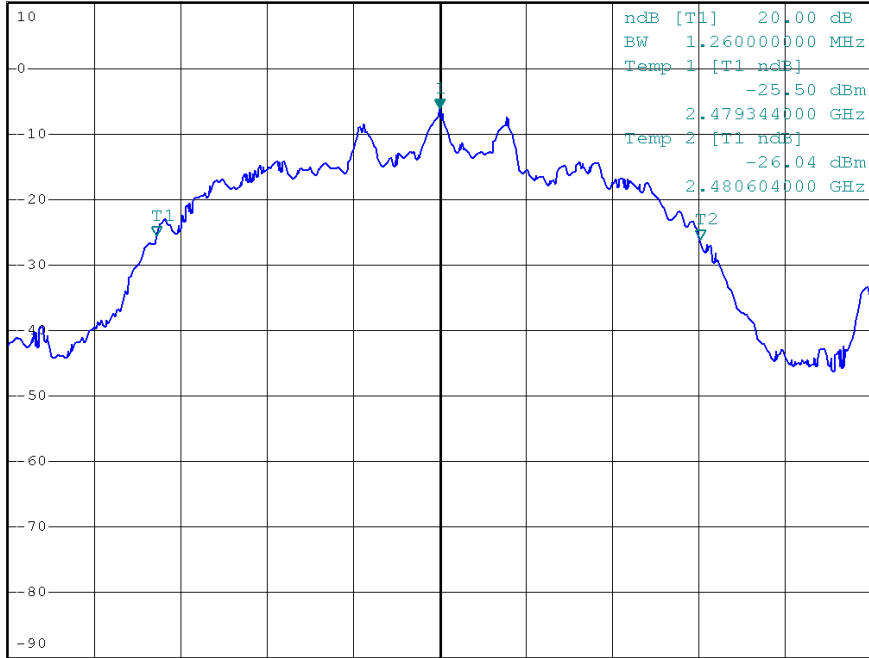

Center 2.48 GHz

200 kHz/

Span 2 MHz

ndB [T1]	20.00 dB
BW	1.260000000 MHz
Temp 1 [T1 ndB]	-25.50 dBm
	2.479344000 GHz
Temp 2 [T1 ndB]	-26.04 dBm
	2.480604000 GHz



7. Frequencies Separation

7.1 Test Limit

Frequency hopping systems shall have hopping channel carrier frequencies separated by a minimum of 25 kHz or the 20 dB bandwidth of the hopping channel, whichever is greater.

7.2 Test Procedures

- a. The transmitter output was connected to the spectrum analyzer.
- b. Set RBW of spectrum analyzer to 100 KHz and VBW to 100 KHz.
- c. By using the MaxHold function record the separation of two adjacent channels.
- d. Measure the frequency difference of these two adjacent channels.

7.3 Test Setup Layout

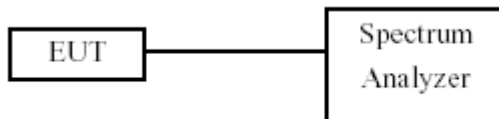

7.4 Measurement equipment

Instrument/Ancillary	Model No.	Manufacturer	Serial No.	Calibration Date	Valid Date
Spectrum Analyzer	R&S	FSP40	100047	2011/05/05	2012/05/04



7.5 Test Result and Data

Modulation Standard: GFSK (1Mbps)

Test Date: Jul. 06, 2011

Temperature: 25

Atmospheric pressure: 1020 hPa

Humidity: 65%

Channel	Frequency (MHz)	Channel Separation (MHz)
00	2402	1.004
39	2441	1.000
78	2480	1.004

Modulation Standard: $\pi/4$ -DQPSK (2Mbps)

Test Date: Jul. 06, 2011

Temperature: 25

Atmospheric pressure: 1020 hPa

Humidity: 65%

Channel	Frequency (MHz)	Channel Separation (MHz)
00	2402	1.002
39	2441	1.004
78	2480	1.009

Modulation Standard: 8DPSK (3Mbps)

Test Date: Jul. 06, 2011

Temperature: 25

Atmospheric pressure: 1020 hPa

Humidity: 65%

Channel	Frequency (MHz)	Channel Separation (MHz)
00	2402	1.008
39	2441	0.996
78	2480	1.008



Modulation Standard: GFSK (1Mbps)
Channel: 00

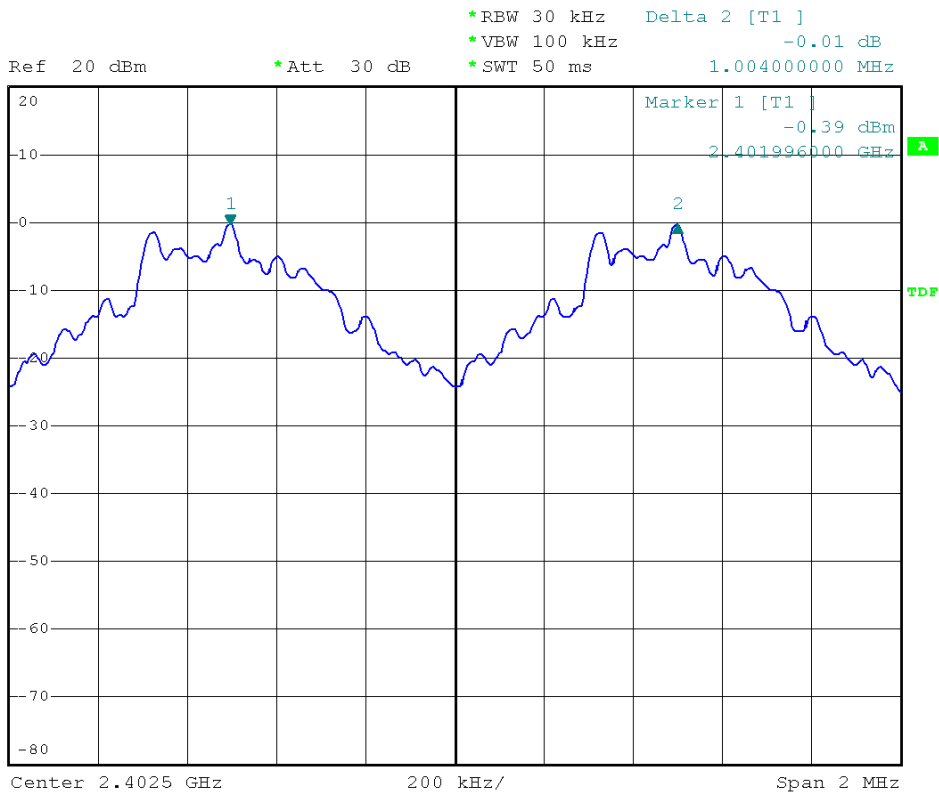

Modulation Standard: GFSK (1Mbps)
Channel: 39

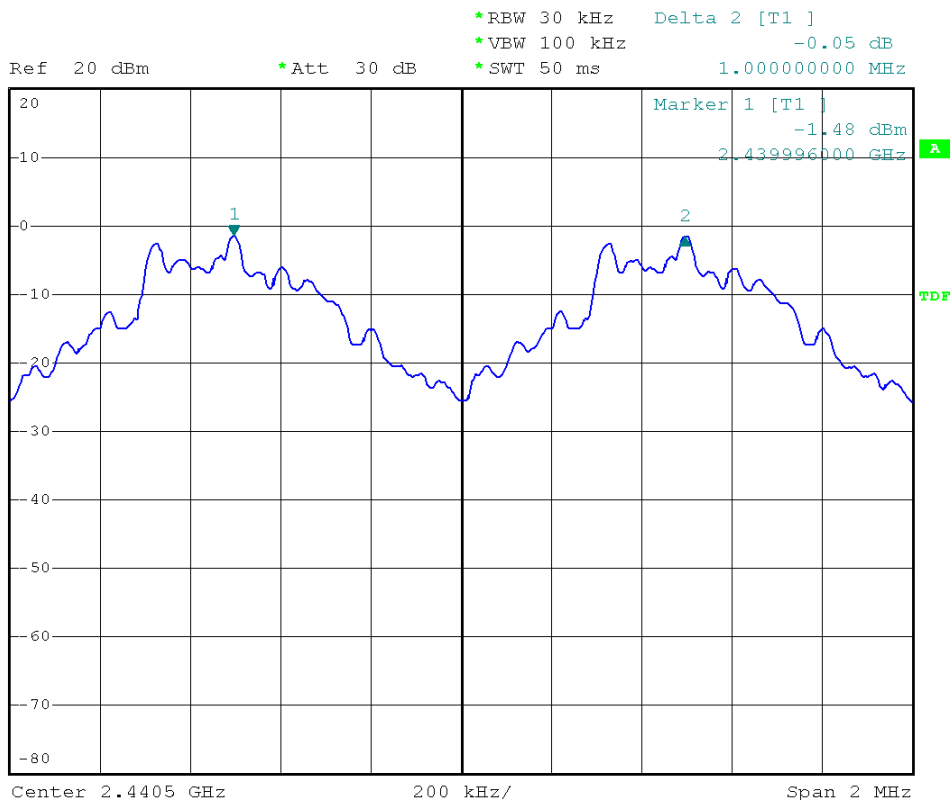



Modulation Standard: GFSK (1Mbps)
Channel: 78

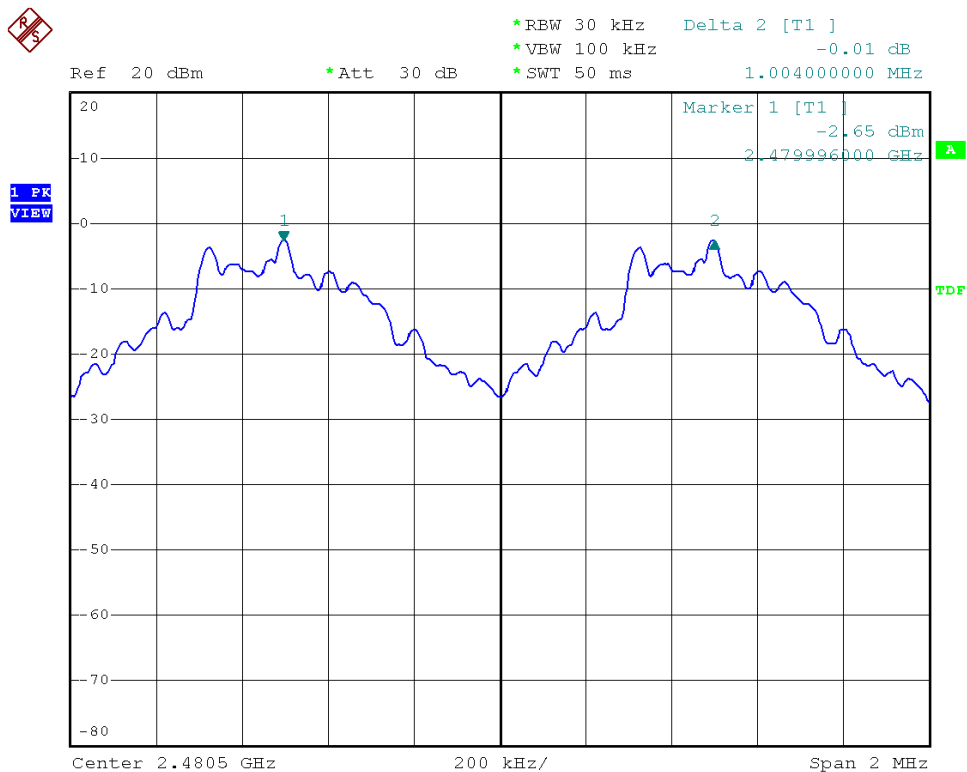

Modulation Standard: $\pi/4$ -DQPSK (2Mbps)
Channel: 00

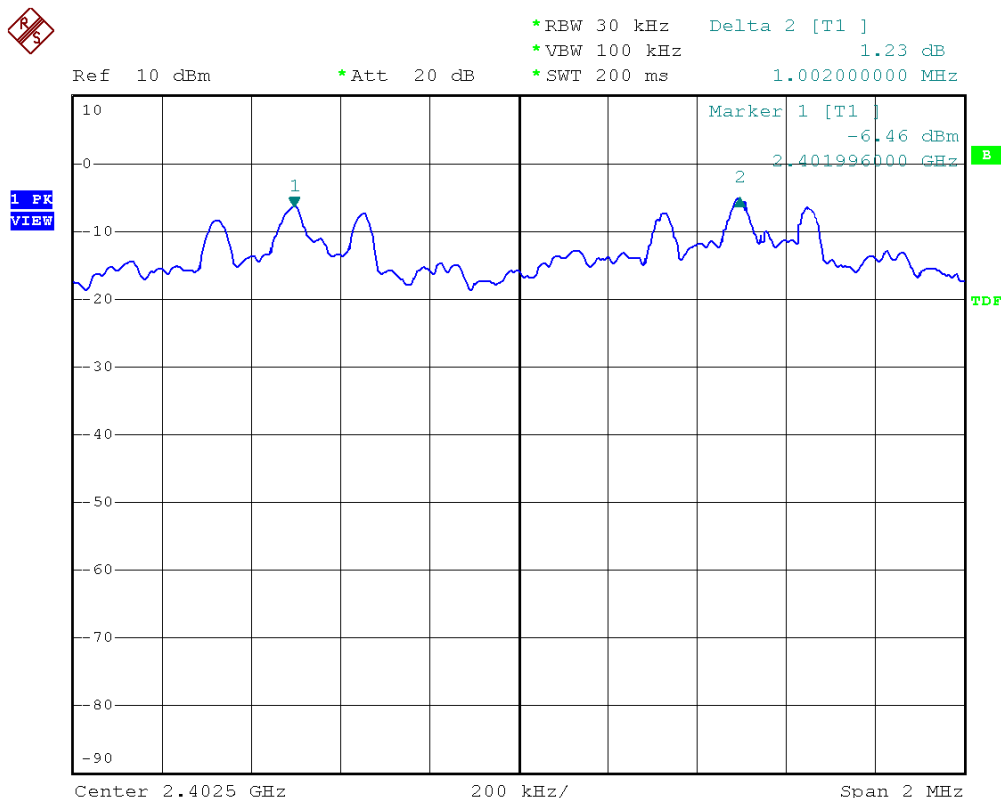



Modulation Standard: $\pi/4$ -DQPSK (2Mbps)
Channel: 39

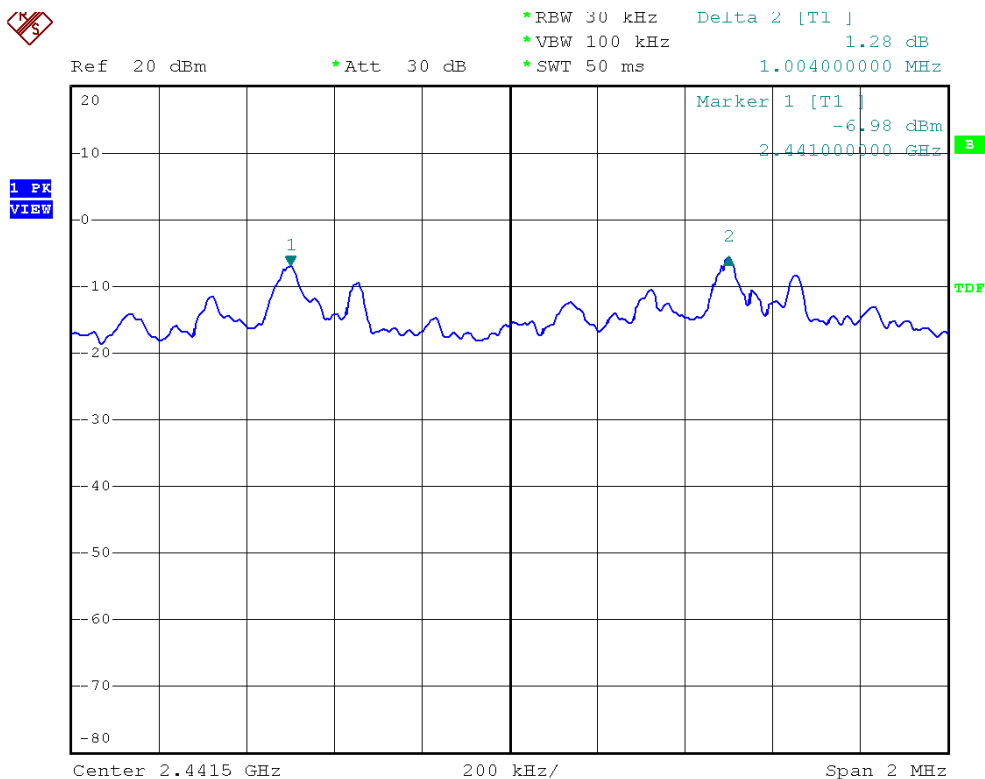

Modulation Standard: $\pi/4$ -DQPSK (2Mbps)
Channel: 78

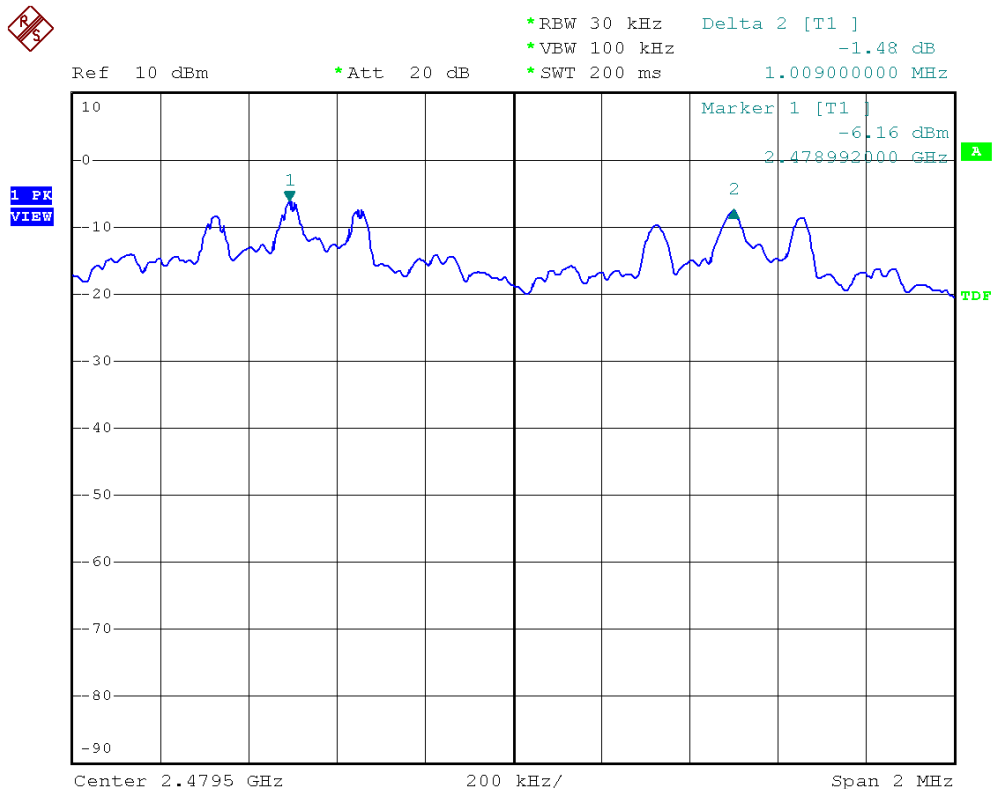



Modulation Standard: 8DQPSK (3Mbps)
Channel: 00

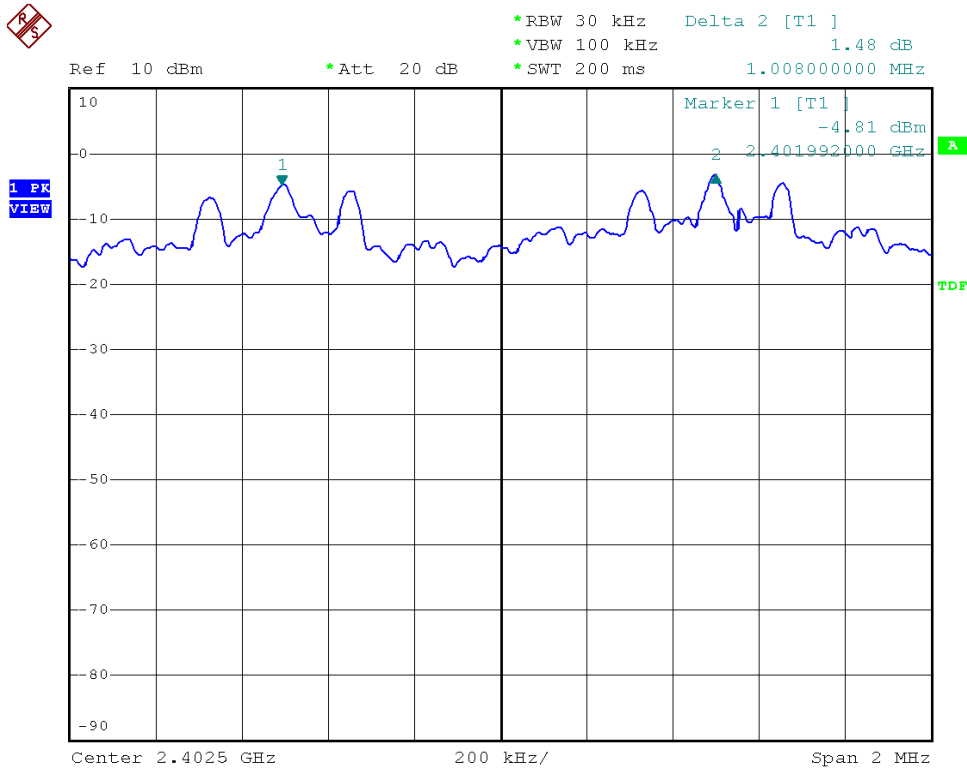

Modulation Standard: 8DQPSK (3Mbps)
Channel: 39

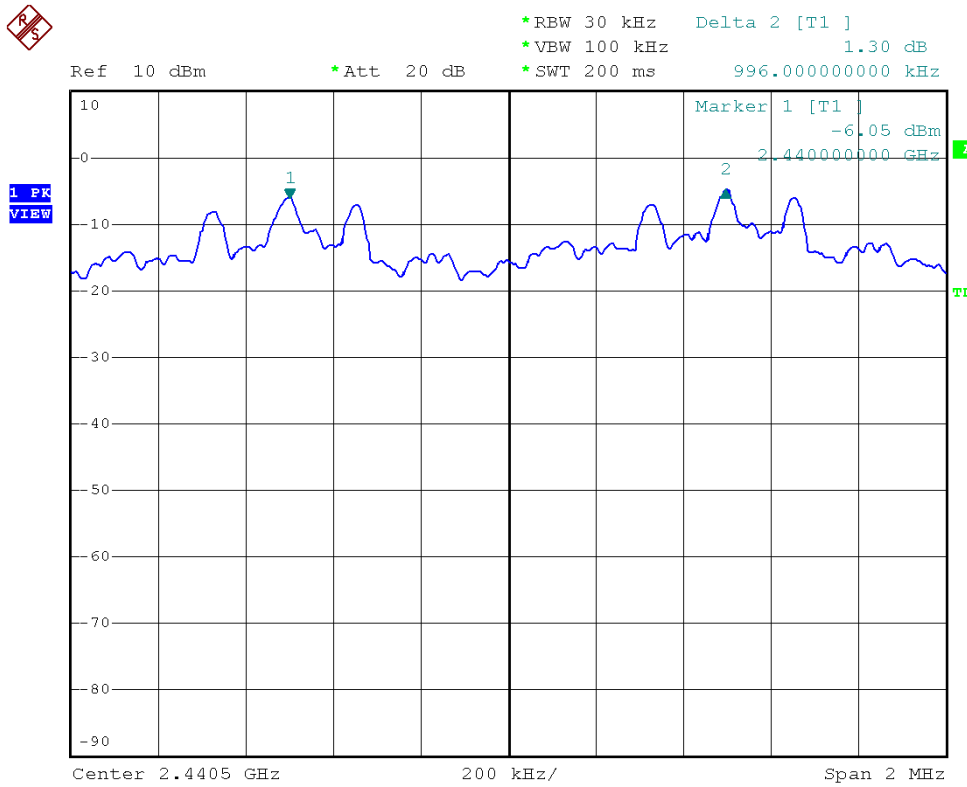



Modulation Standard: 8DQPSK (3Mbps)
Channel: 78

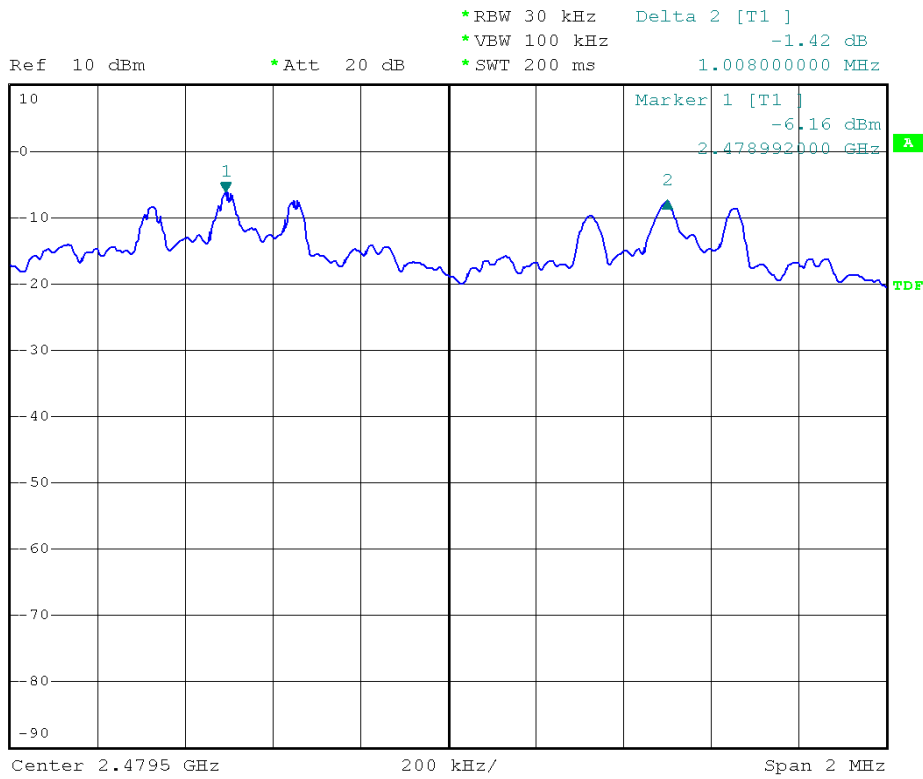



8. Dwell Time on each channel

8.1 Test Limit

The average time of occupancy on any channel shall not be greater than 0.4 seconds within a period of 0.4 seconds multiplied by the number of hopping channels employed.

8.2 Test Procedures

1. The transmitter output was connected to the spectrum analyzer.
2. Adjust the center frequency to measure frequency, then set zero span mode.
2. Set RBW of spectrum analyzer to 100 KHz and VBW to 100 KHz.
4. Measure the time duration of one transmission on the measured frequency.

8.3 Test Setup Layout

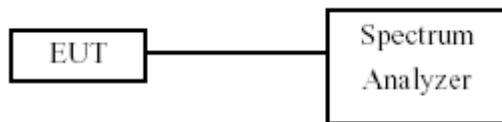

8.4 Measurement equipment

Instrument/Ancillary	Model No.	Manufacturer	Serial No.	Calibration Date	Valid Date
Spectrum Analyzer	R&S	FSP40	100047	2011/05/05	2012/05/04



8.5 Test Result and Data

Modulation Standard: GFSK (1Mbps)

Test Date: Jul. 06, 2011

Temperature: 25

Atmospheric pressure: 1020 hPa

Humidity: 65%

a) 2402 MHz Dwell Time is	=	132.48 ms
b) 2441 MHz Dwell Time is	=	132.48 ms
c) 2480 MHz Dwell Time is	=	130.56 ms

Modulation Standard: $\pi/4$ -DQPSK (2Mbps)

Test Date: Jul. 06, 2011

Temperature: 25

Atmospheric pressure: 1020 hPa

Humidity: 65%

a) 2402 MHz Dwell Time is	=	323.84 ms
b) 2441 MHz Dwell Time is	=	322.96 ms
c) 2480 MHz Dwell Time is	=	323.84 ms

Modulation Standard: 8DPSK (3Mbps)

Test Date: Jul. 06, 2011

Temperature: 25

Atmospheric pressure: 1020 hPa

Humidity: 65%

a) 2402 MHz Dwell Time is	=	323.84 ms
b) 2441 MHz Dwell Time is	=	324.72 ms
c) 2480 MHz Dwell Time is	=	323.84 ms



Modulation Standard: GFSK (1Mbps)
Channel: 00

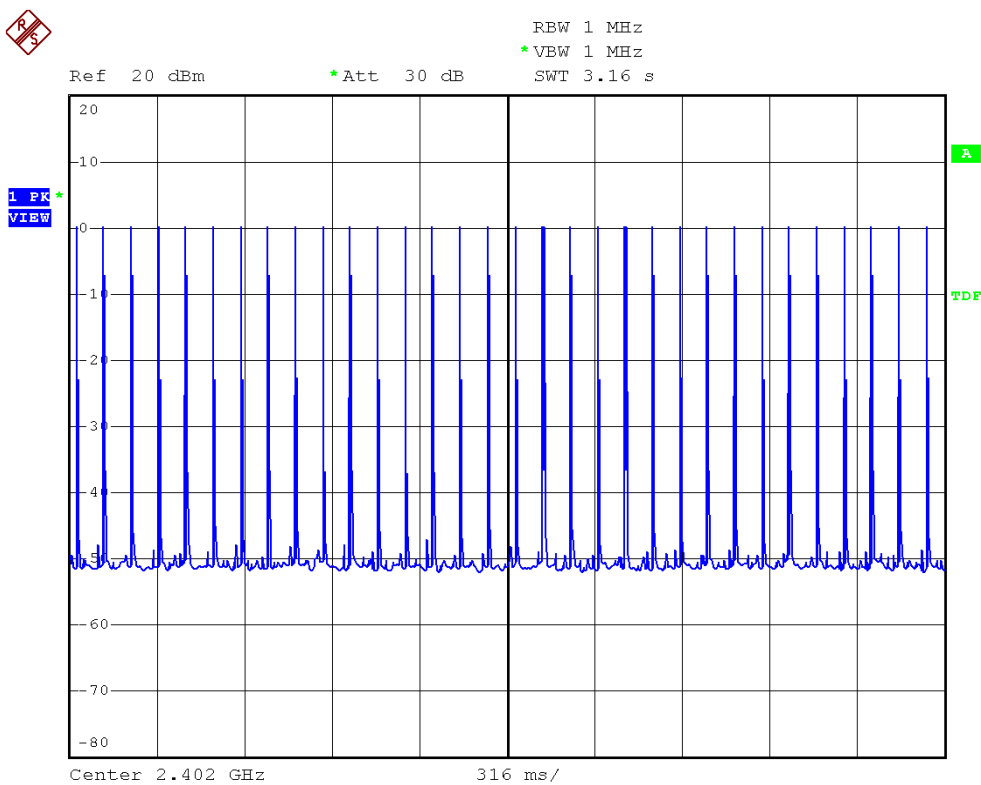
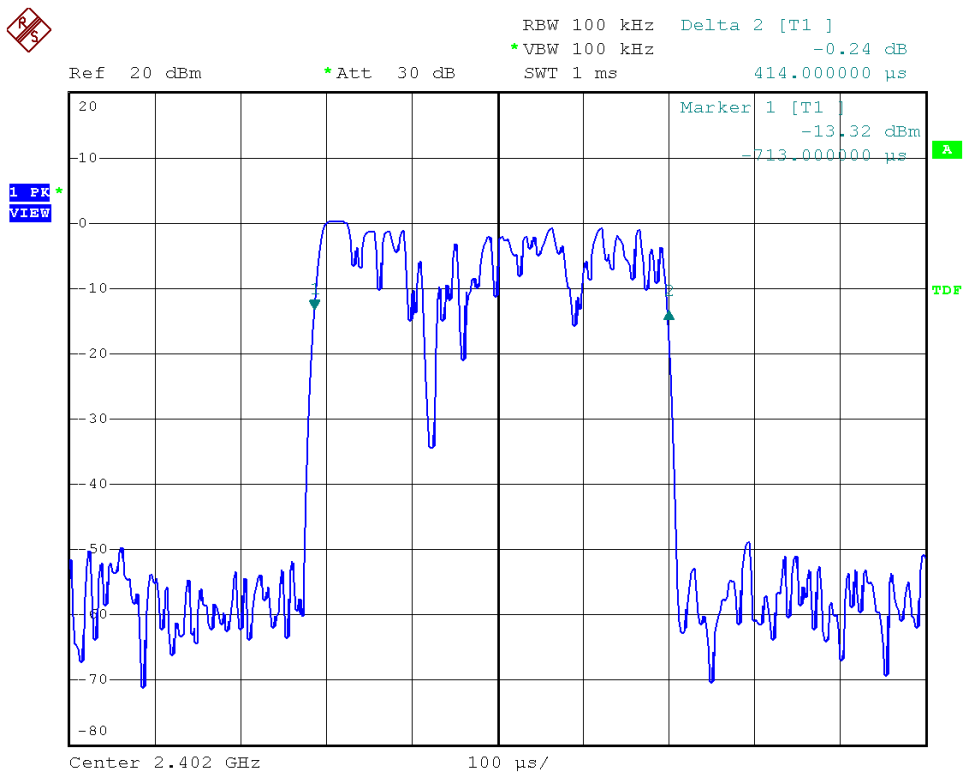



Modulation Standard: GFSK (1Mbps)
Channel: 39

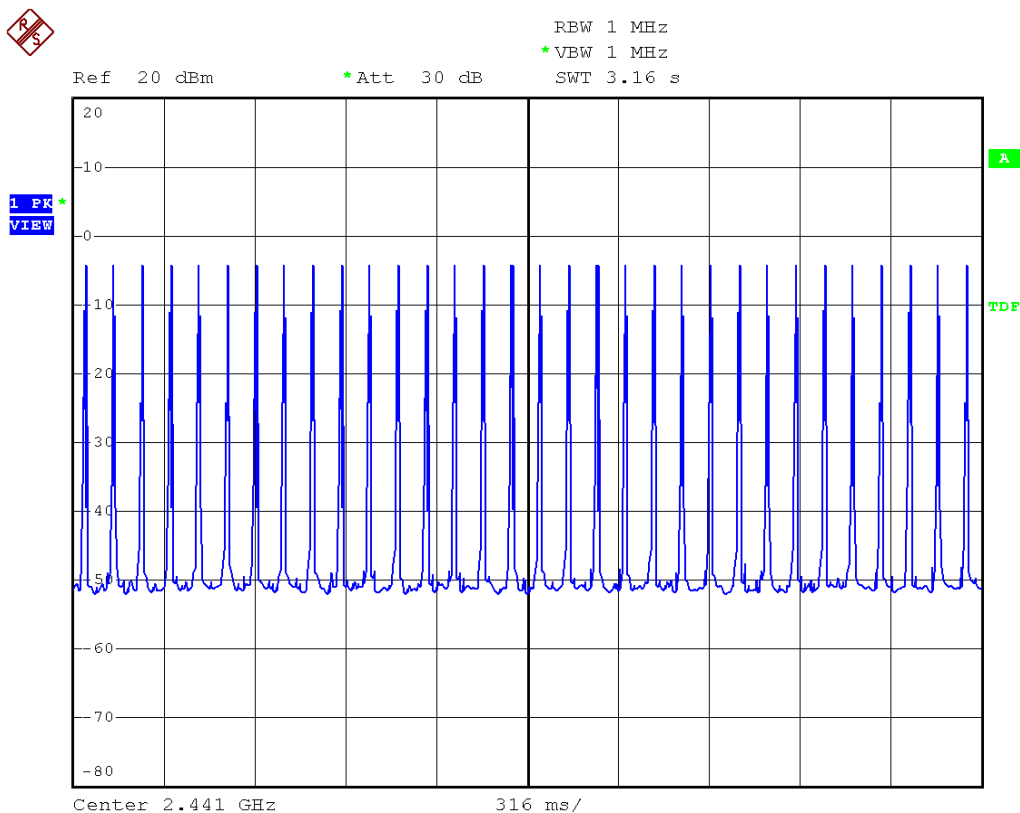
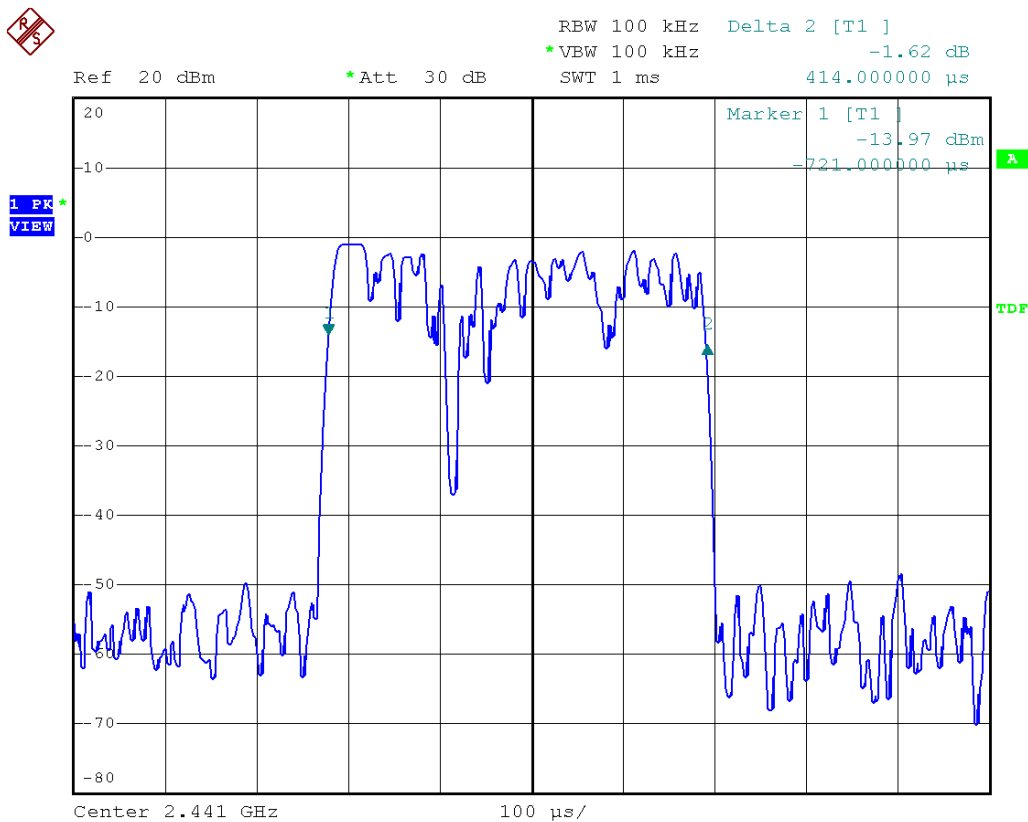



Modulation Standard: GFSK (1Mbps)
Channel: 78



Ref 20 dBm *Att 30 dB RBW 100 kHz Delta 2 [T1] 2.45 dB
*VBW 100 kHz SWT 1 ms 408.000000 μ s

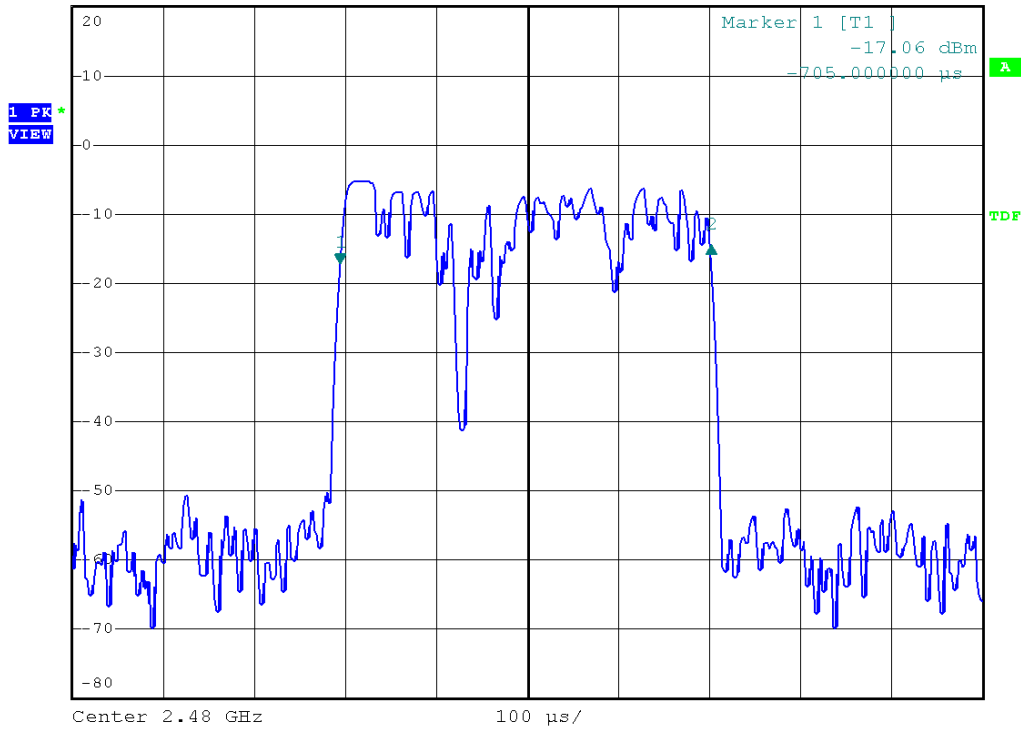

Ref 20 dBm *Att 30 dB RBW 1 MHz Delta 2 [T1] 0.00 dB
*VBW 1 MHz SWT 3.16 s 408.000000 μ s

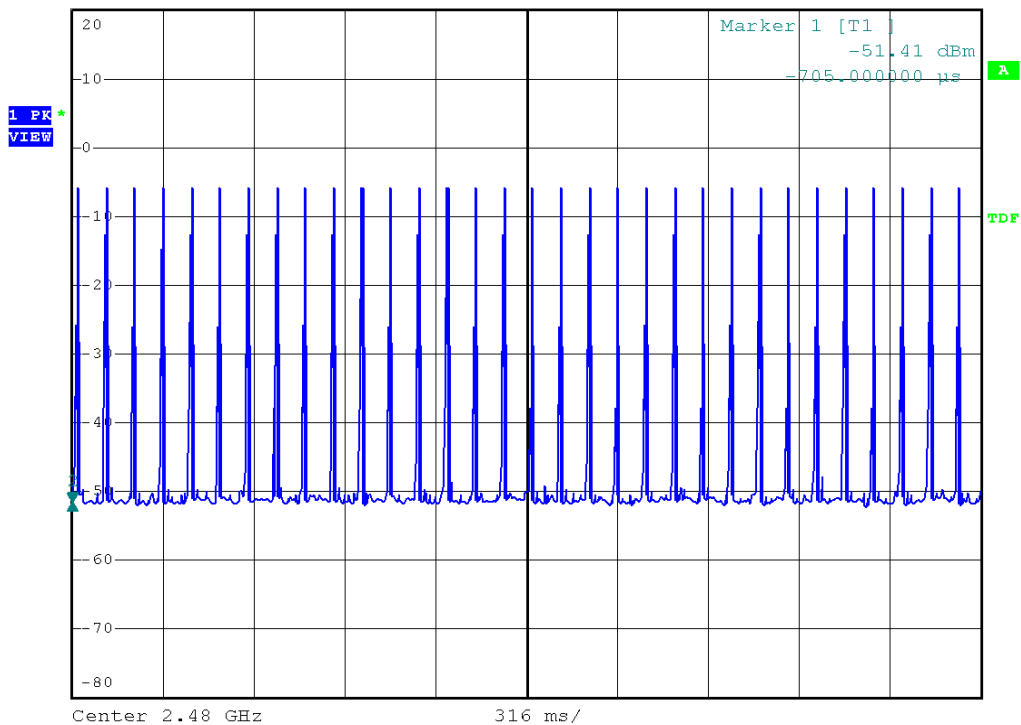



Modulation Standard: $\pi/4$ -DQPSK (2Mbps)
Channel: 00

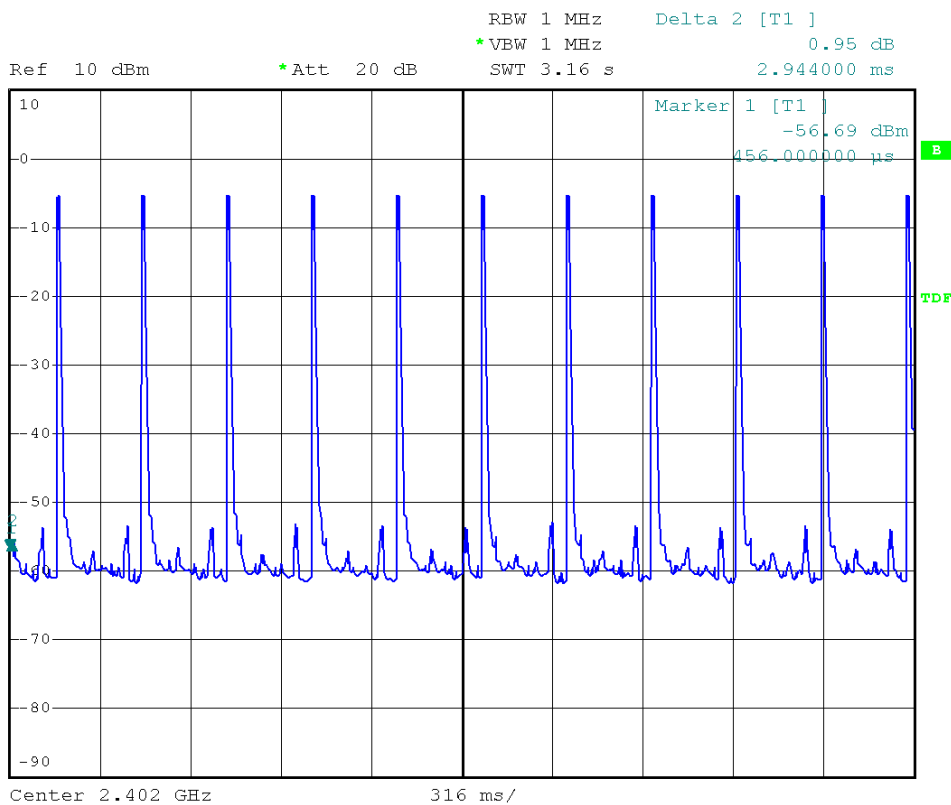
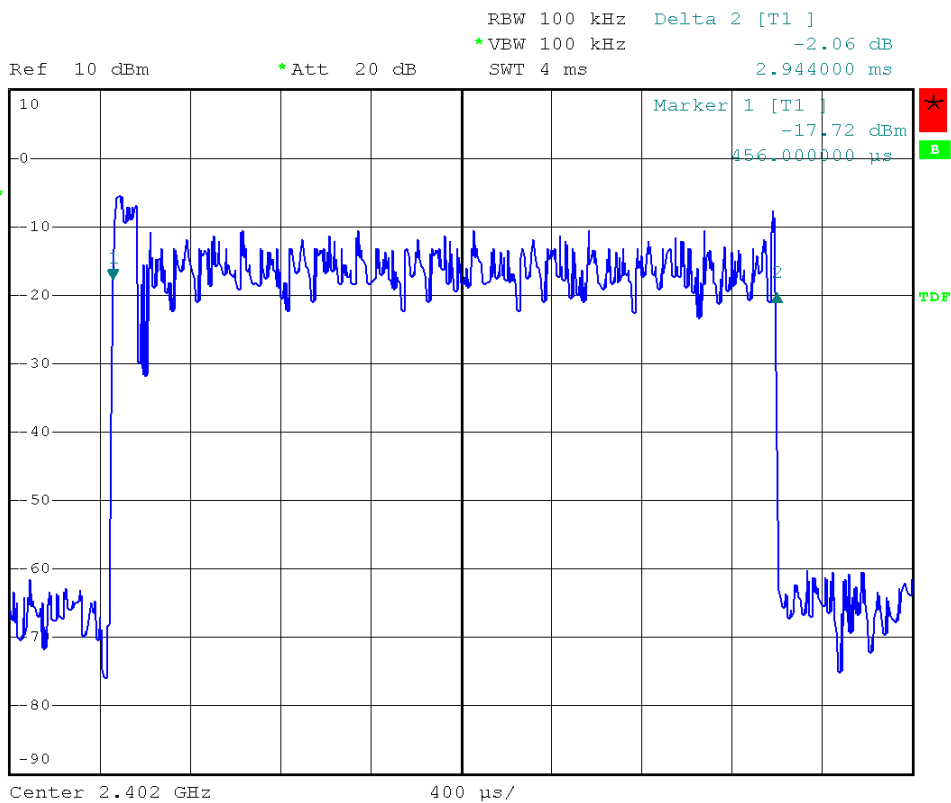



Modulation Standard: $\pi/4$ -DQPSK (2Mbps)
Channel: 39

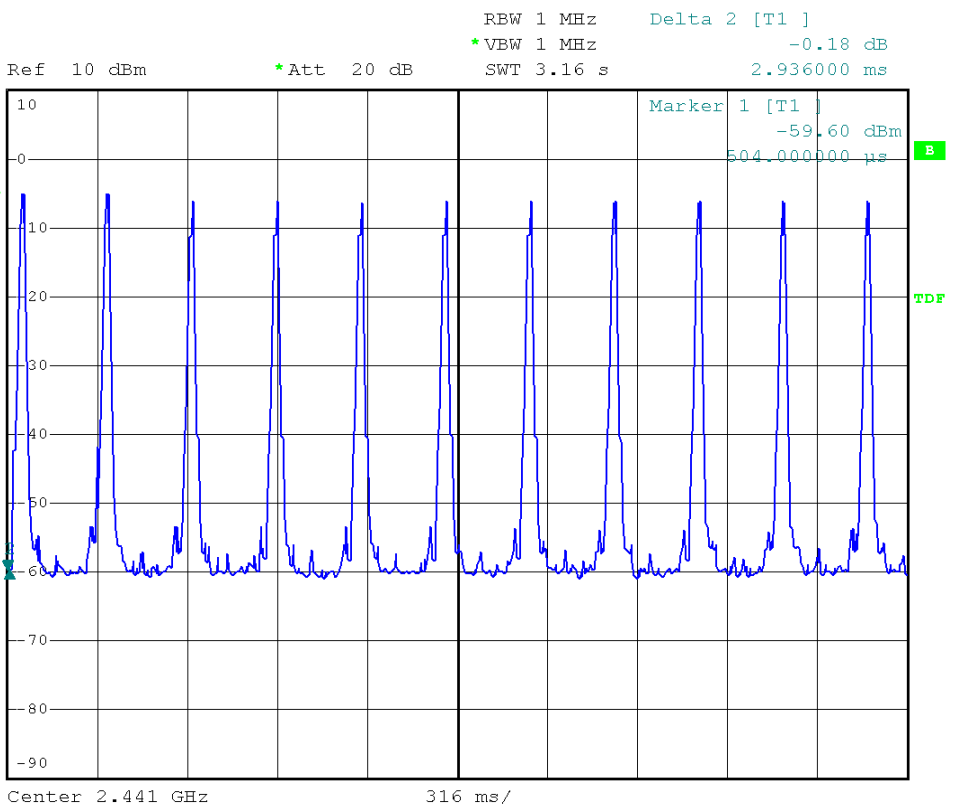
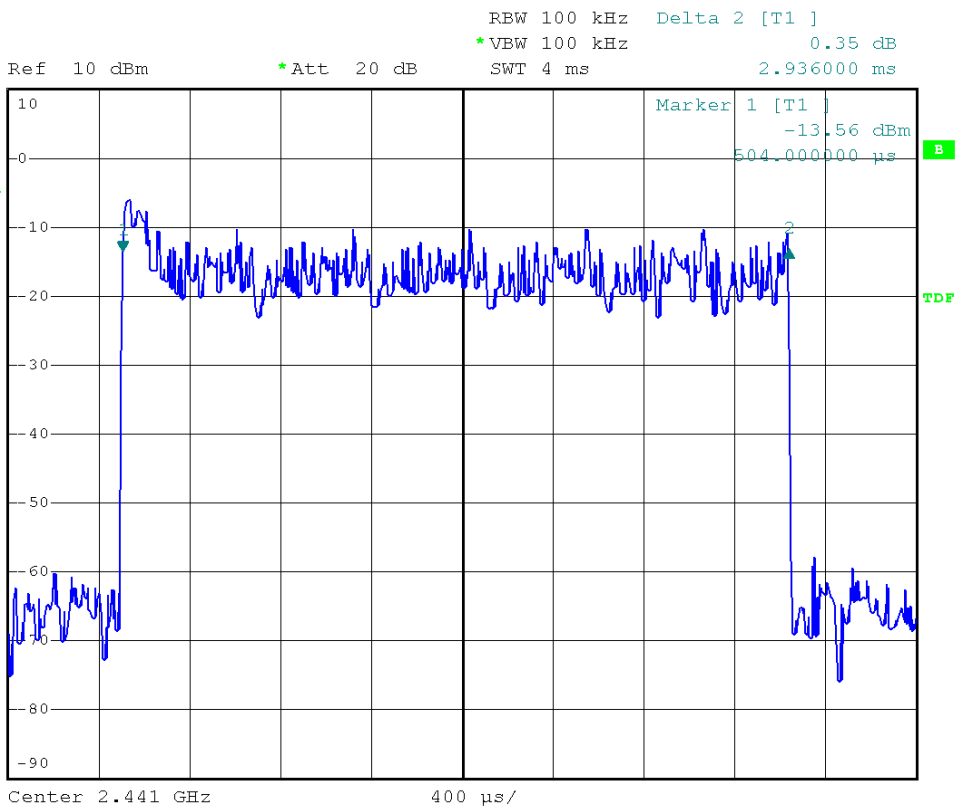



Modulation Standard: $\pi/4$ -DQPSK (2Mbps)
Channel: 78

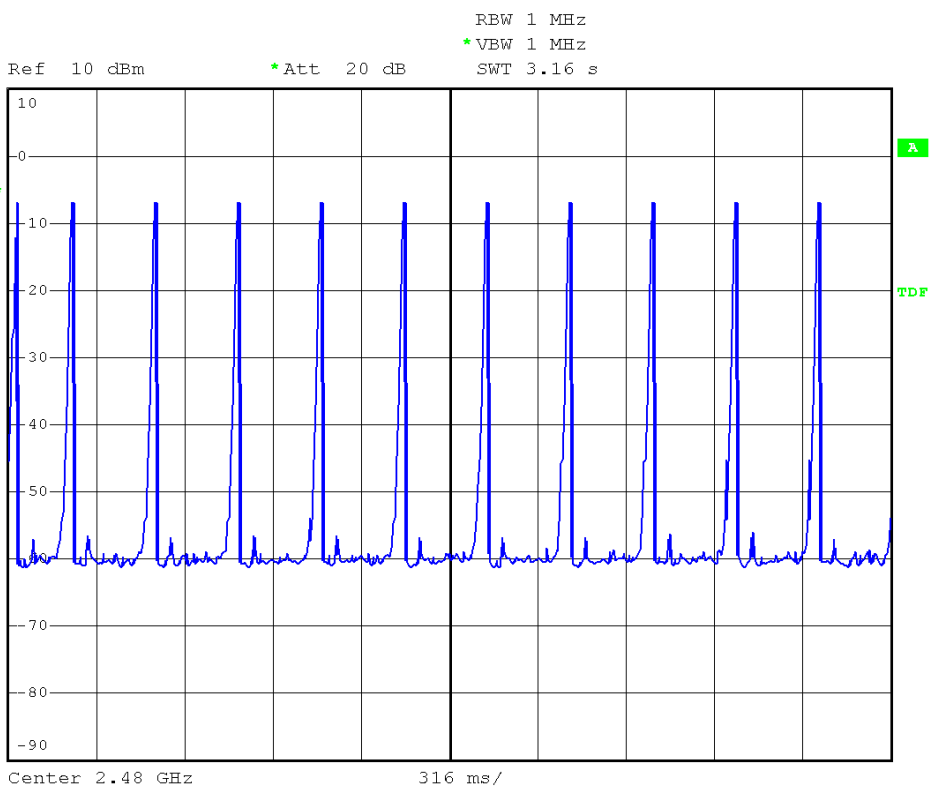
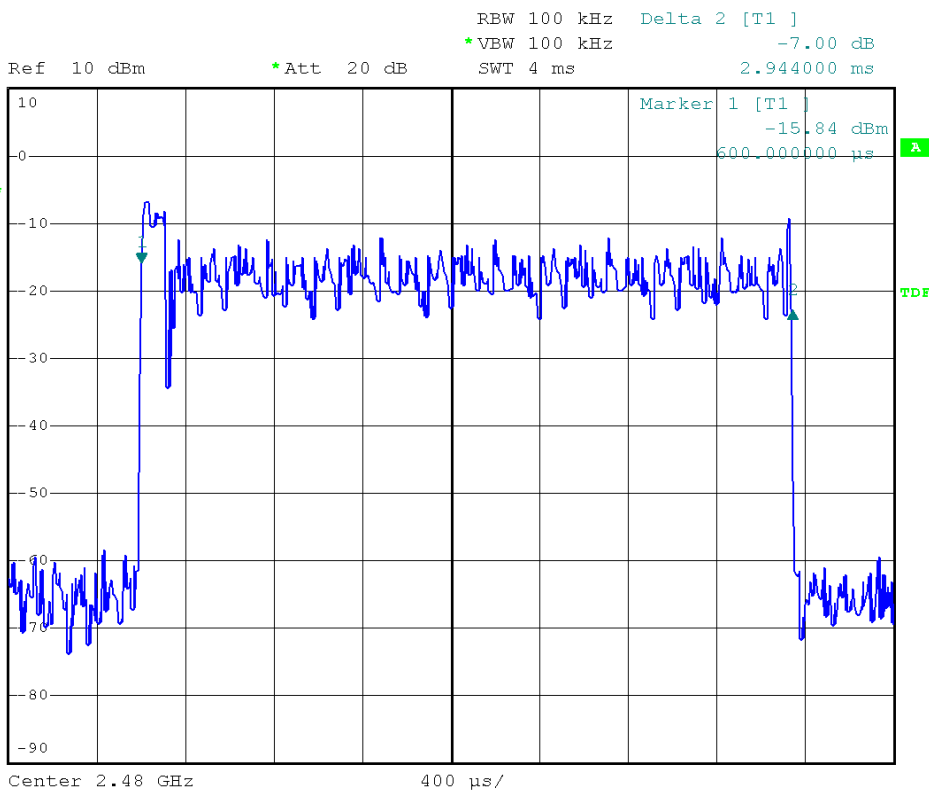



Modulation Standard: 8DPSK (3Mbps)
Channel: 00

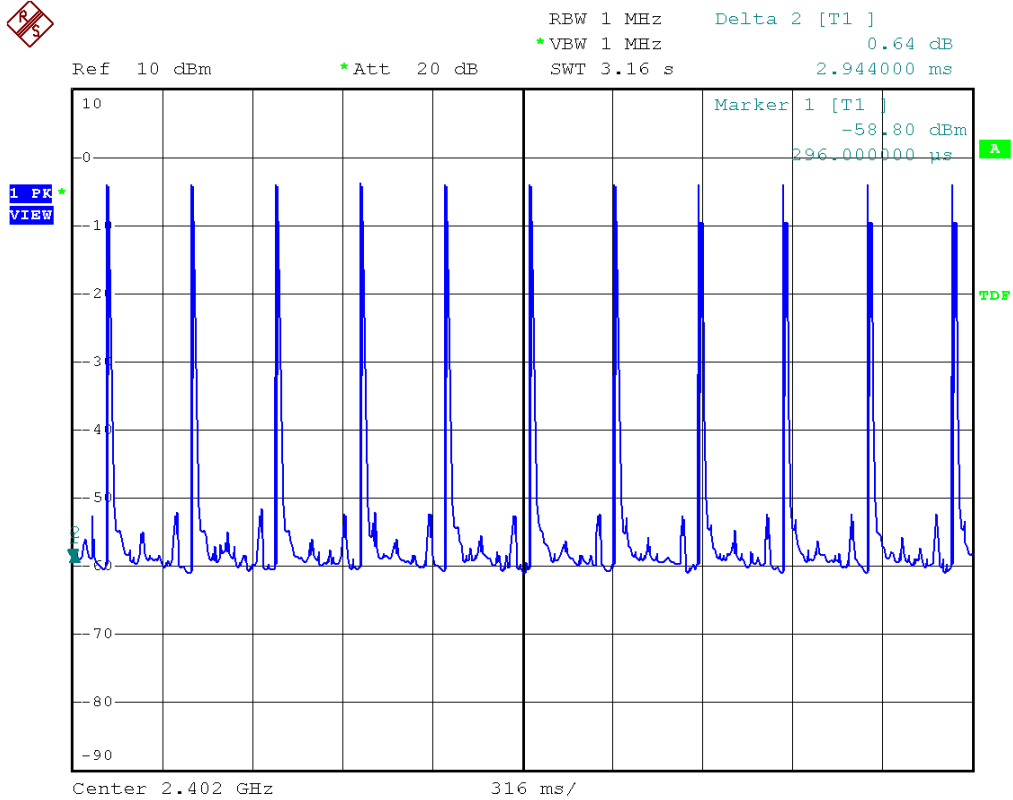
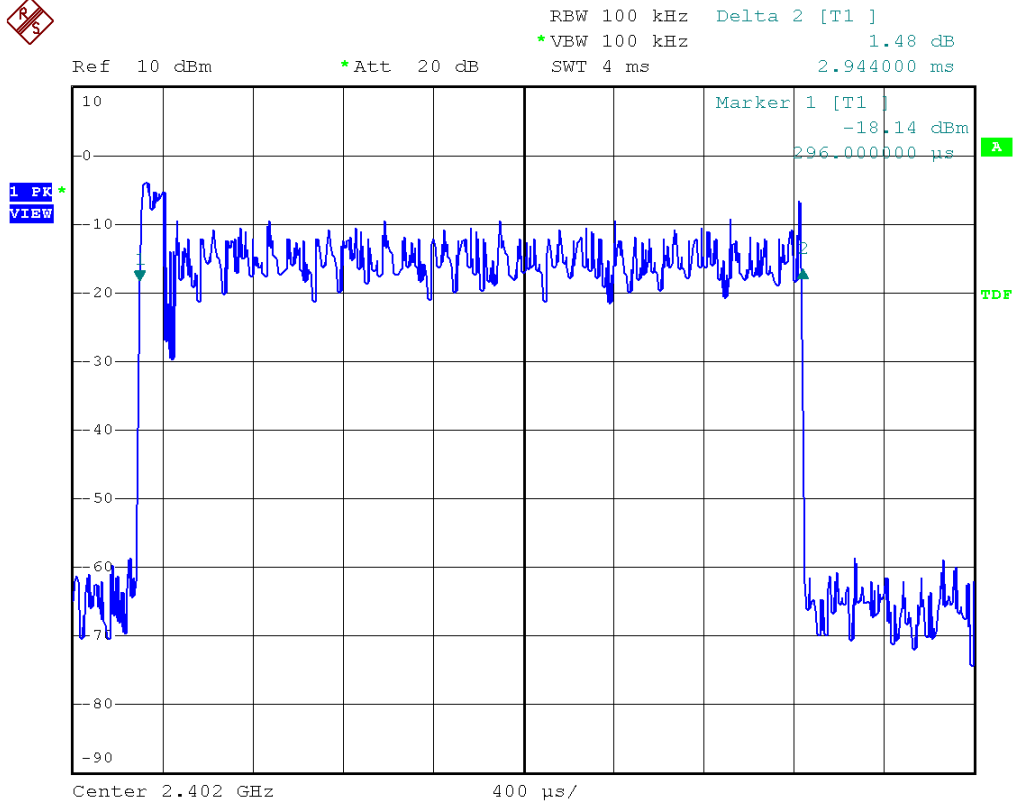



Modulation Standard: 8DPSK (3Mbps)
Channel: 39

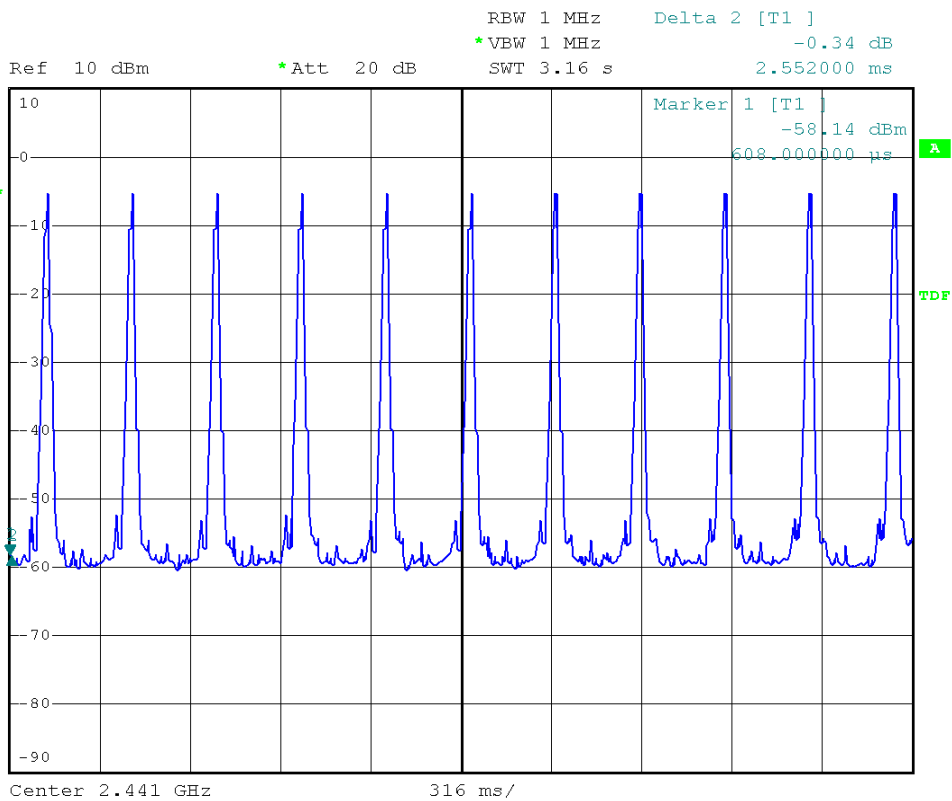
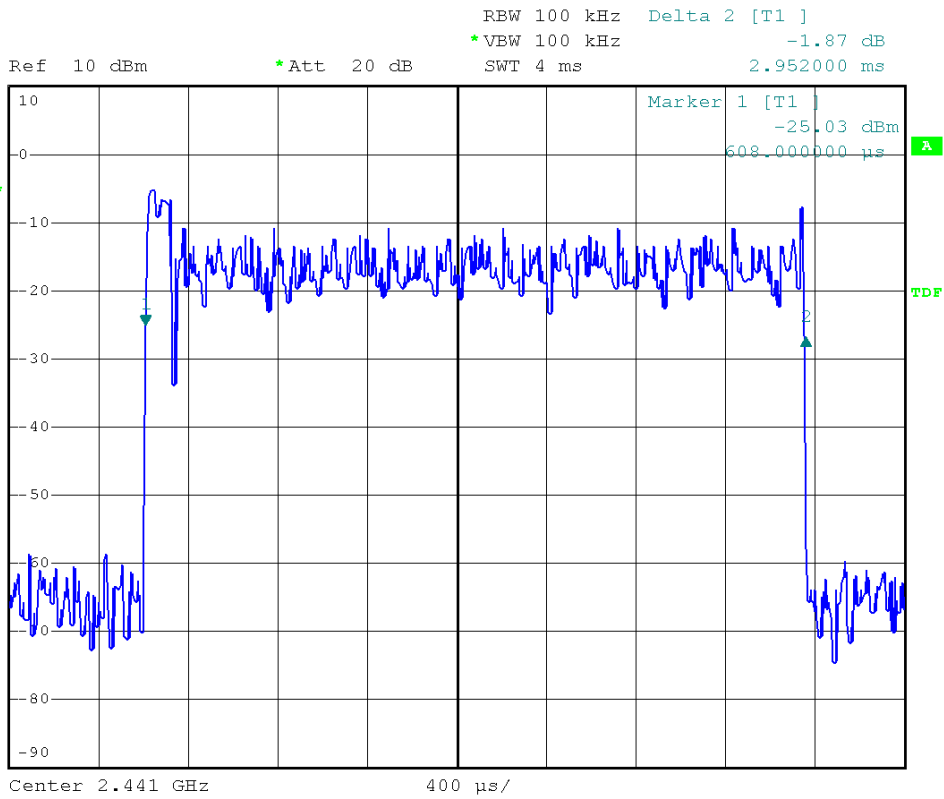



Modulation Standard: 8DPSK (3Mbps)
Channel: 78

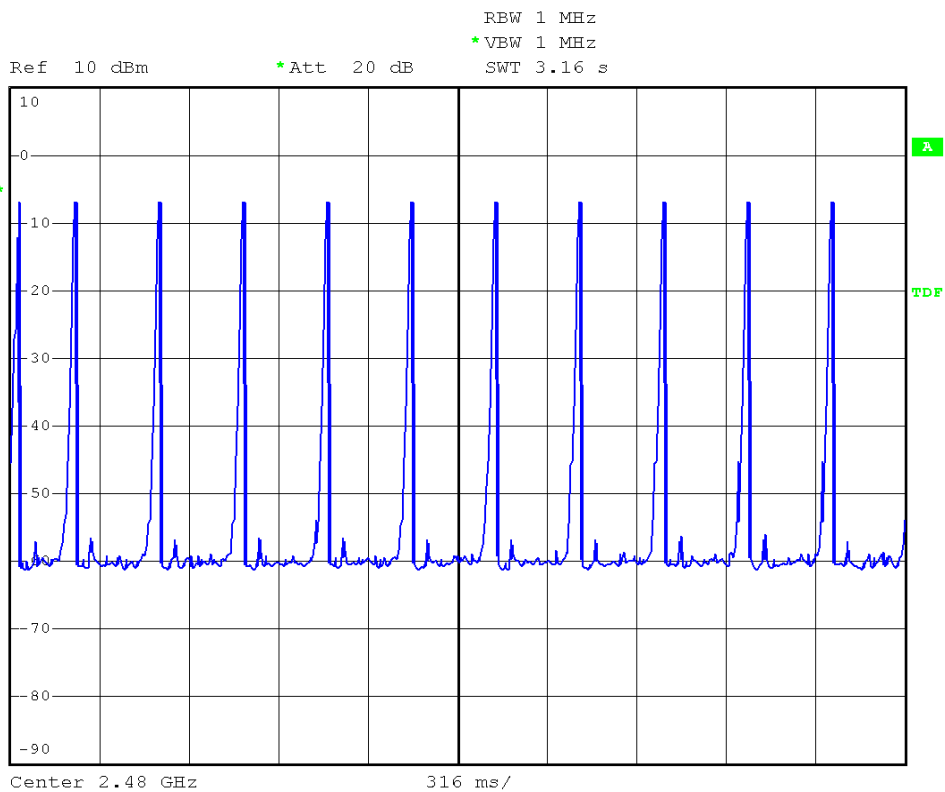
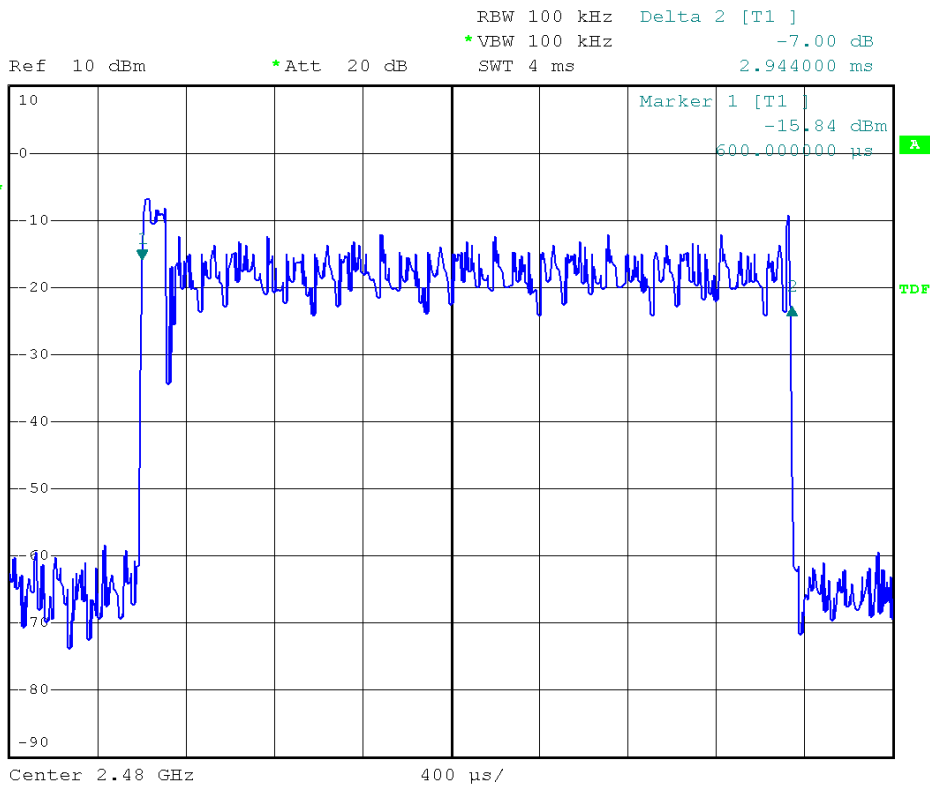



9. Number of Hopping Channels

9.1 Test Limit

Frequency hopping systems in the 2400 ~ 2483.5 MHz band shall use at least 15 channels.

9.2 Test Procedures

- a. The transmitter output was connected to the spectrum analyzer.
- b. 2. Set RBW of spectrum analyzer to 100 KHz and VBW to 100 KHz.
- c. 3. Set the MaxHold function, and then keep the EUT in hopping mode. Record all the signals from each channel until each one has been record.

9.3 Test Setup Layout

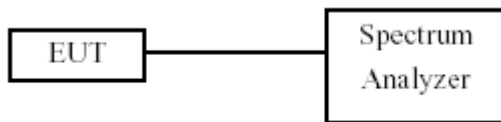

9.4 Measurement equipment

Instrument/Ancillary	Model No.	Manufacturer	Serial No.	Calibration Date	Valid Date
Spectrum Analyzer	R&S	FSP40	100047	2011/05/05	2012/05/04

9.5 Test Result and Data

Modulation Standard: GFSK (1Mbps)

Test Date: Jul. 06, 2011

Temperature: 25

Atmospheric pressure: 1020 hPa

Humidity: 65%

Number of hopping channels:	79	Channels
-----------------------------	----	----------

Modulation Standard: $\pi/4$ -DQPSK (2Mbps)

Test Date: Jul. 06, 2011

Temperature: 25

Atmospheric pressure: 1020 hPa

Humidity: 65%

Number of hopping channels:	79	Channels
-----------------------------	----	----------

Modulation Standard: 8DPSK (3Mbps)

Test Date: Jul. 06, 2011

Temperature: 25

Atmospheric pressure: 1020 hPa

Humidity: 65%

Number of hopping channels:	79	Channels
-----------------------------	----	----------



Modulation Standard: GFSK (1Mbps)

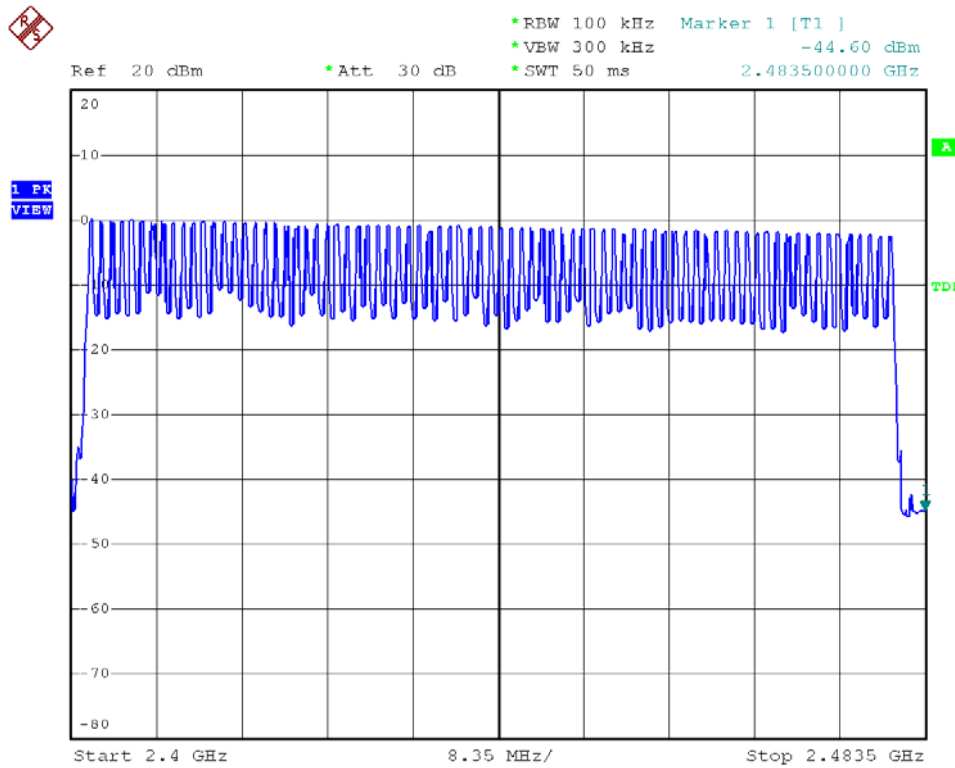

Modulation Standard: $\pi/4$ -DQPSK (2Mbps)

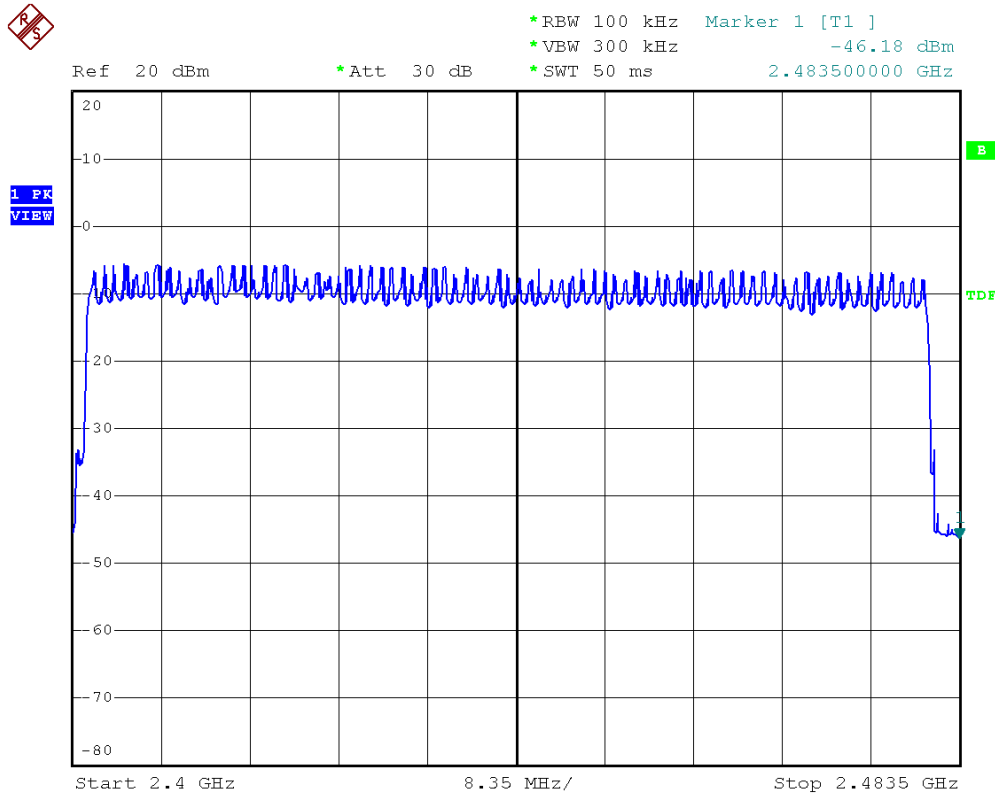



Modulation Standard: 8DPSK (3Mbps)

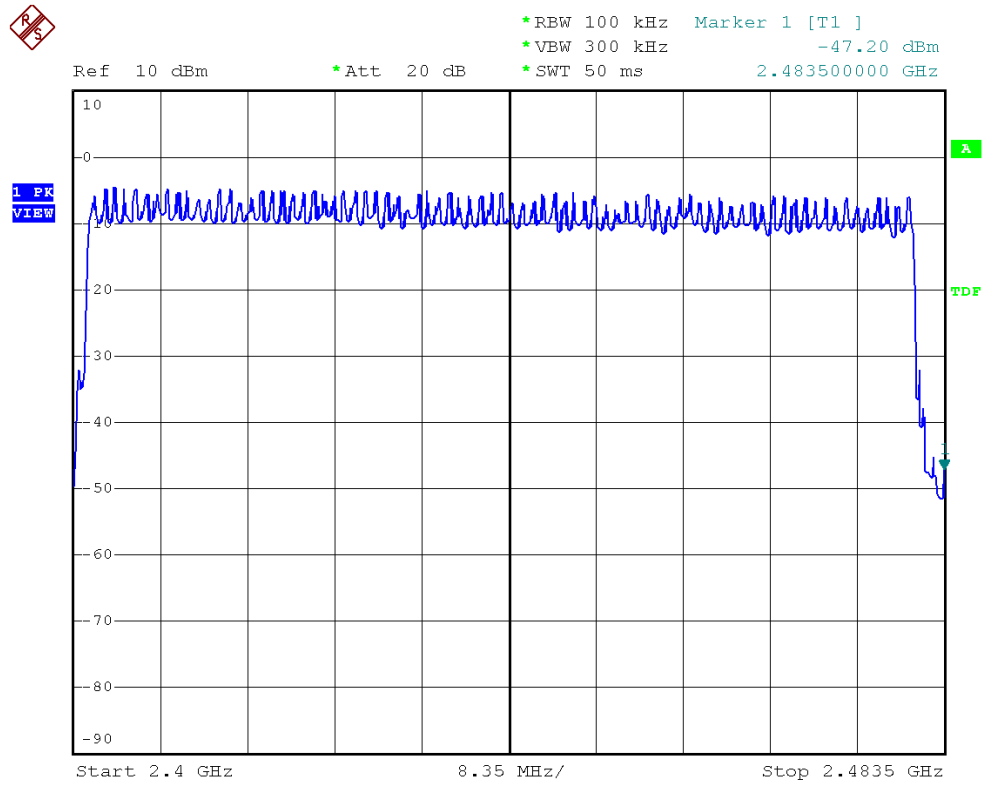



10. Maximum Peak Output Power

10.1 Test Limit

The Maximum Peak Output Power Measurement is 30dBm.

10.2 Test Procedures

The antenna port(RF output)of the EUT was connected to the input(RF input)of a power meter. Power was read directly from the meter and cable loss connection was added to the reading to obtain power at the EUT antenna terminal. The EUT Output Power was set to maximum to produce the worse case test result.

10.3 Test Setup Layout

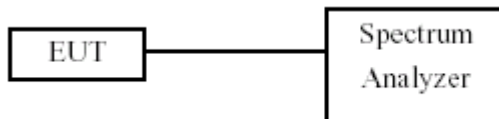

10.4 Measurement equipment

Instrument/Ancillary	Model No.	Manufacturer	Serial No.	Calibration Date	Valid Date
Spectrum Analyzer	R&S	FSP40	100047	2011/05/05	2012/05/04



10.5 Test Result and Data

Modulation Standard: GFSK (1Mbps)

Test Date: Jul. 06, 2011

Temperature: 25

Atmospheric pressure: 1020 hPa

Humidity: 65%

Channel	Frequency (MHz)	Peak Power Output (dBm)	Peak Power Output (mW)
00	2402	-0.04	1.0
39	2441	-0.90	0.8
78	2478	-1.77	0.7

Modulation Standard: $\pi/4$ -DQPSK (2Mbps)

Test Date: Jul. 06, 2011

Temperature: 25

Atmospheric pressure: 1020 hPa

Humidity: 65%

Channel	Frequency (MHz)	Peak Power Output (dBm)	Peak Power Output (mW)
00	2402	-5.13	0.3
39	2441	-5.95	0.3
78	2478	-4.33	0.4

Modulation Standard: 8DPSK (3Mbps)

Test Date: Jul. 06, 2011

Temperature: 25

Atmospheric pressure: 1020 hPa

Humidity: 65%

Channel	Frequency (MHz)	Peak Power Output (dBm)	Peak Power Output (mW)
00	2402	-4.32	0.4
39	2441	-3.87	0.4
78	2478	-4.33	0.4



Modulation Standard: GFSK (1Mbps)
Channel: 78

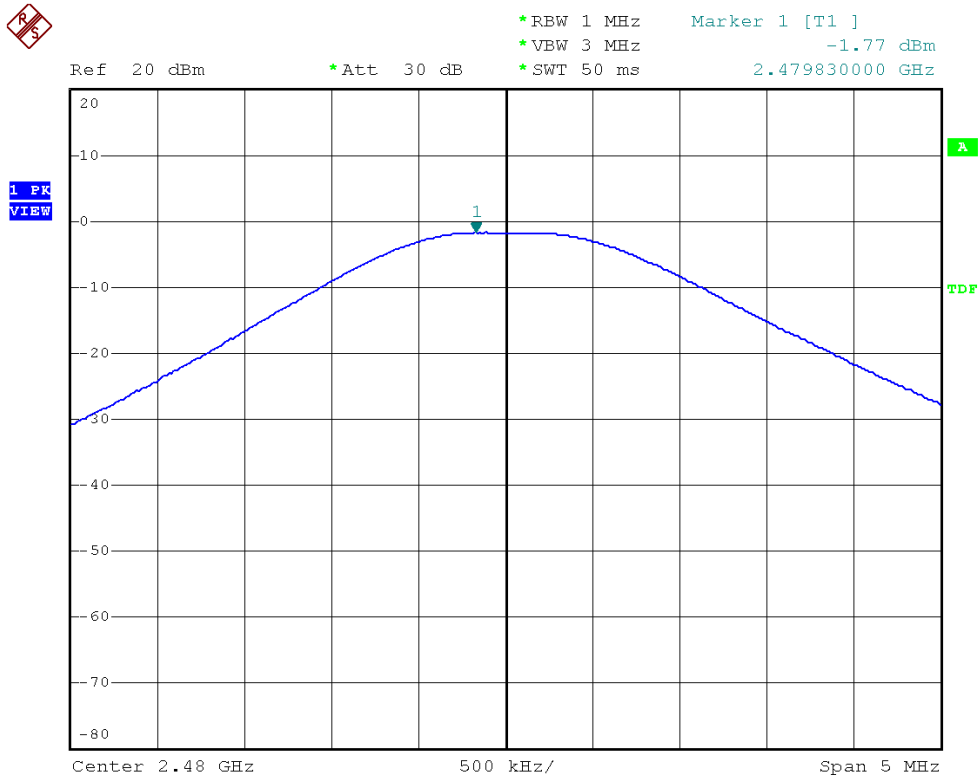

Modulation Standard: $\pi/4$ -DQPSK (2Mbps)
Channel: 00

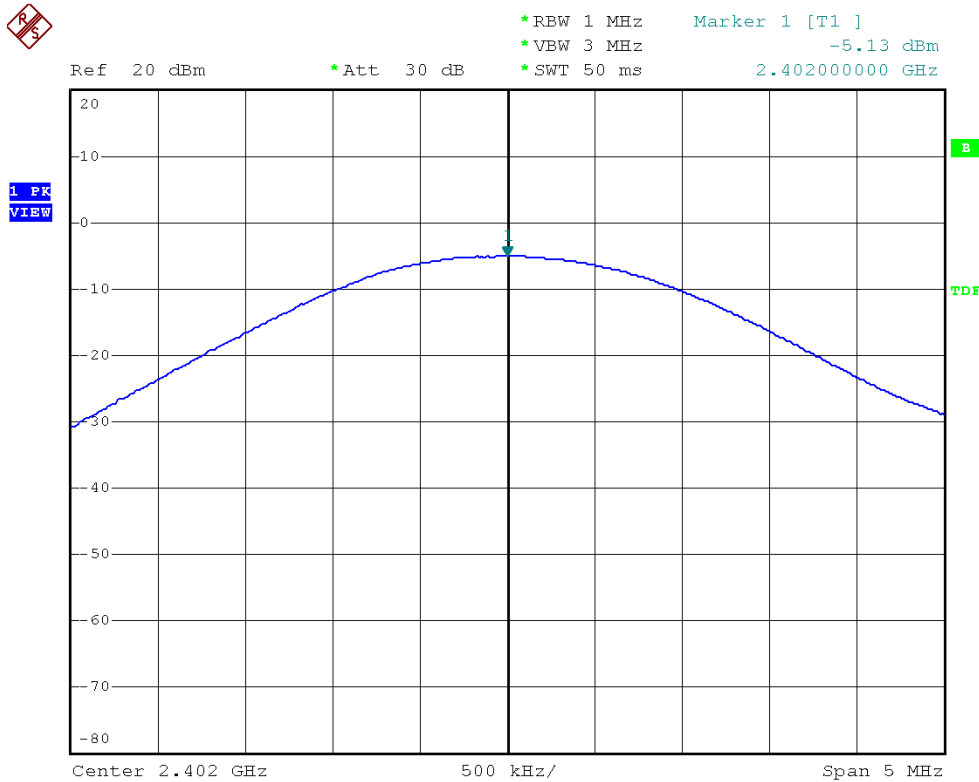



Modulation Standard: $\pi/4$ -DQPSK (2Mbps)
Channel: 39

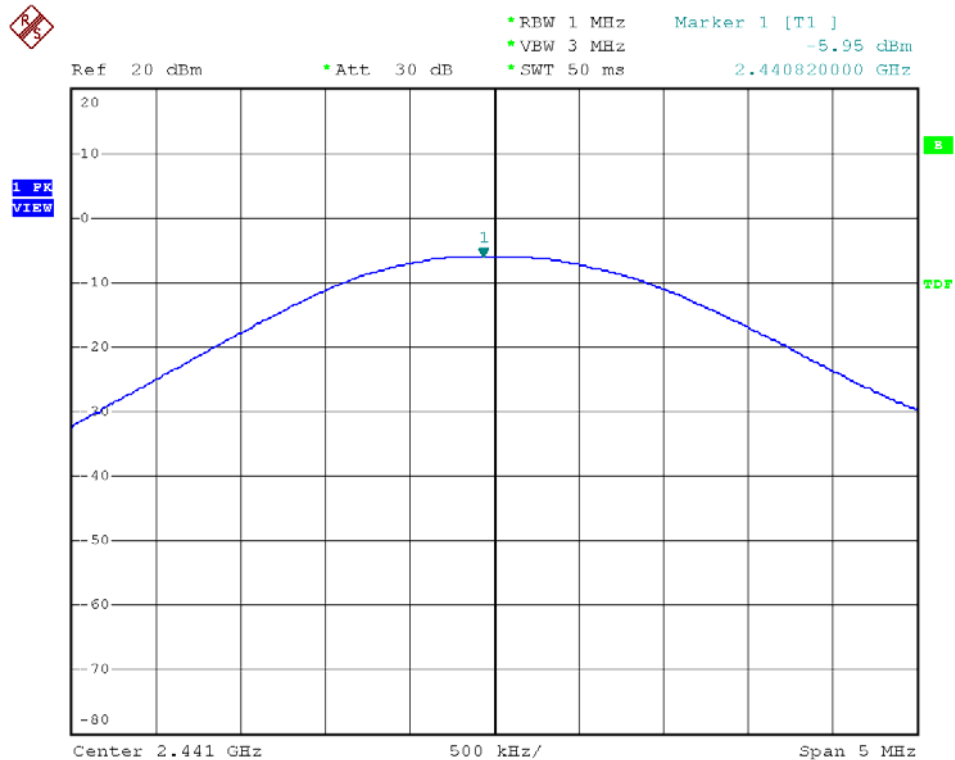

Modulation Standard: $\pi/4$ -DQPSK (2Mbps)
Channel: 78

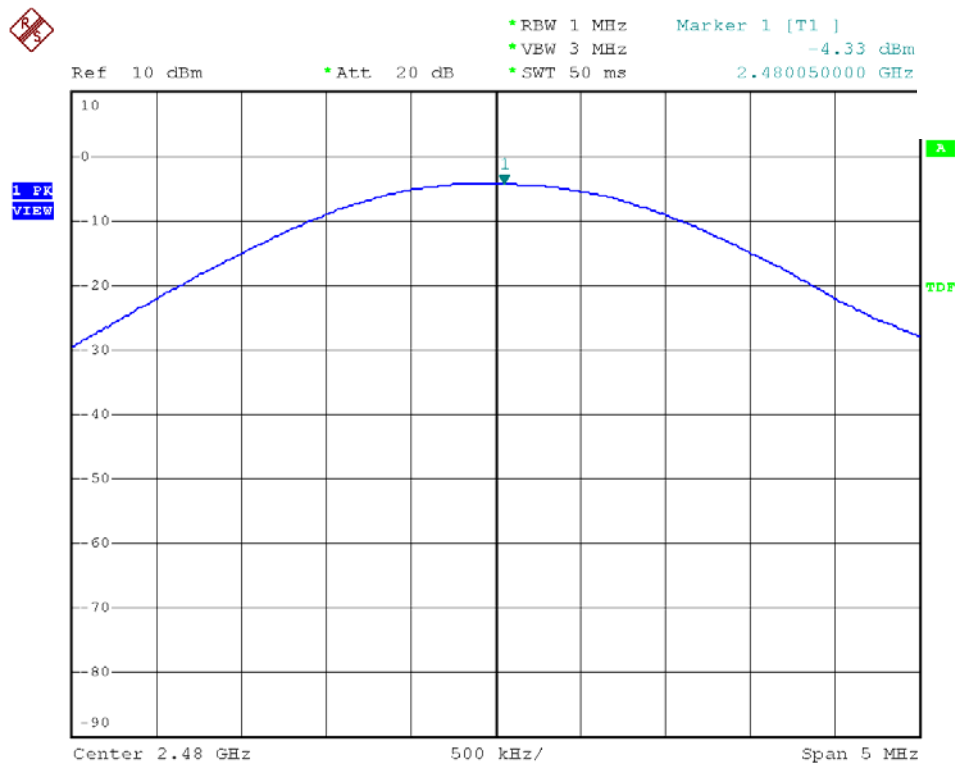



Modulation Standard: 8DPSK (3Mbps)
Channel: 00



Ref 10 dBm *Att 20 dB *RBW 1 MHz Marker 1 [T1] -4.32 dBm
*VBW 3 MHz 2.401990000 GHz
*SWT 50 ms

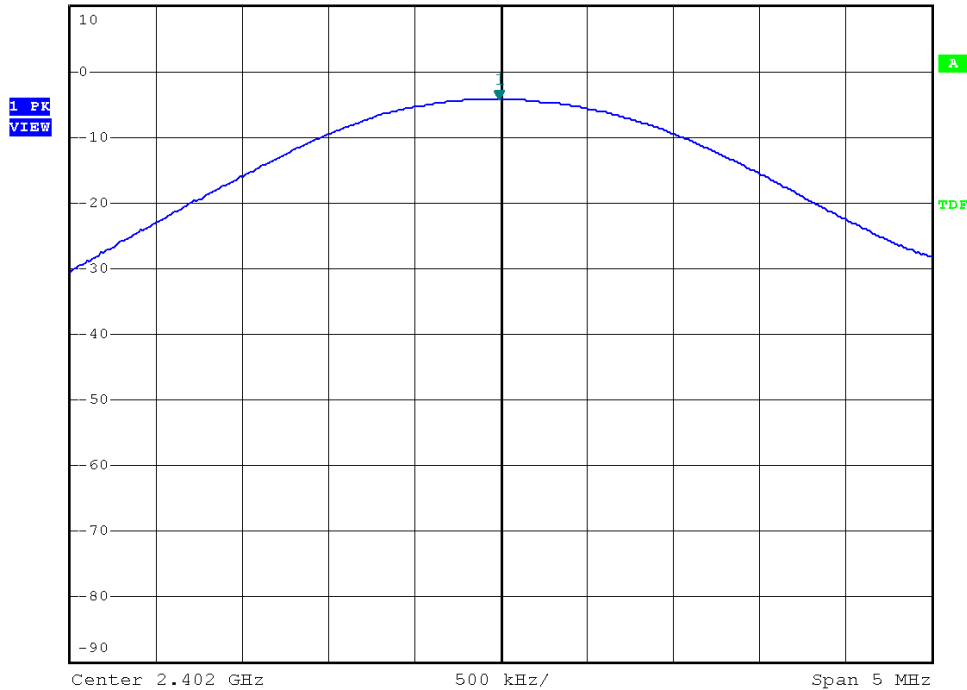

Modulation Standard: 8DPSK (3Mbps)
Channel: 39



Ref 10 dBm *Att 20 dB *RBW 1 MHz Marker 1 [T1] -3.87 dBm
*VBW 3 MHz 2.440870000 GHz
*SWT 50 ms

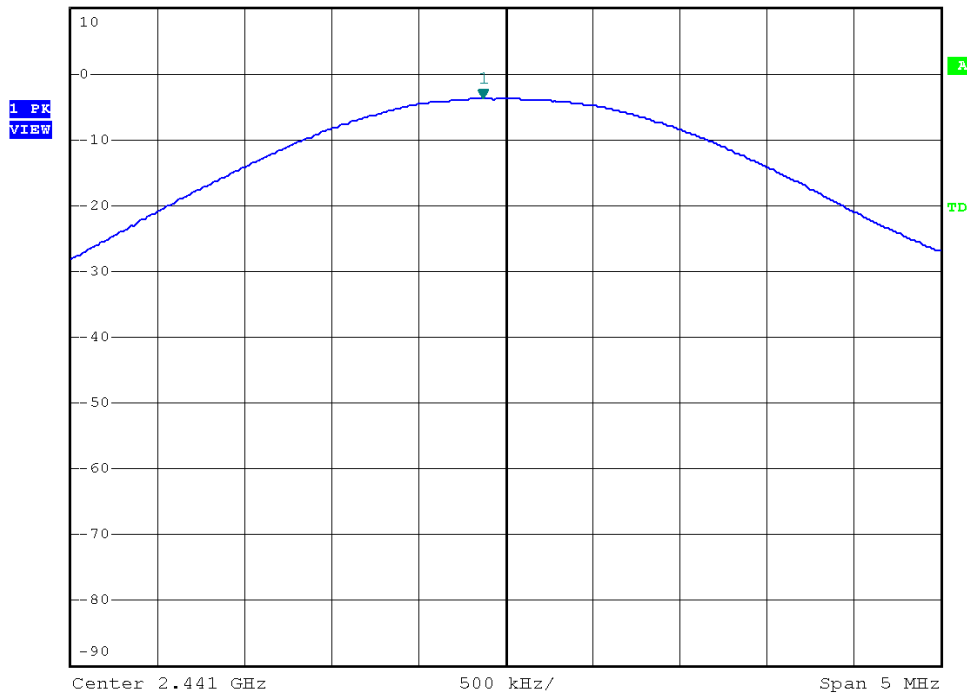



Modulation Standard: 8DPSK (3Mbps)
Channel: 78



Ref 10 dBm *Att 20 dB *RBW 1 MHz Marker 1 [T1]
*VBW 3 MHz -4.33 dBm
*SWT 50 ms 2.480050000 GHz

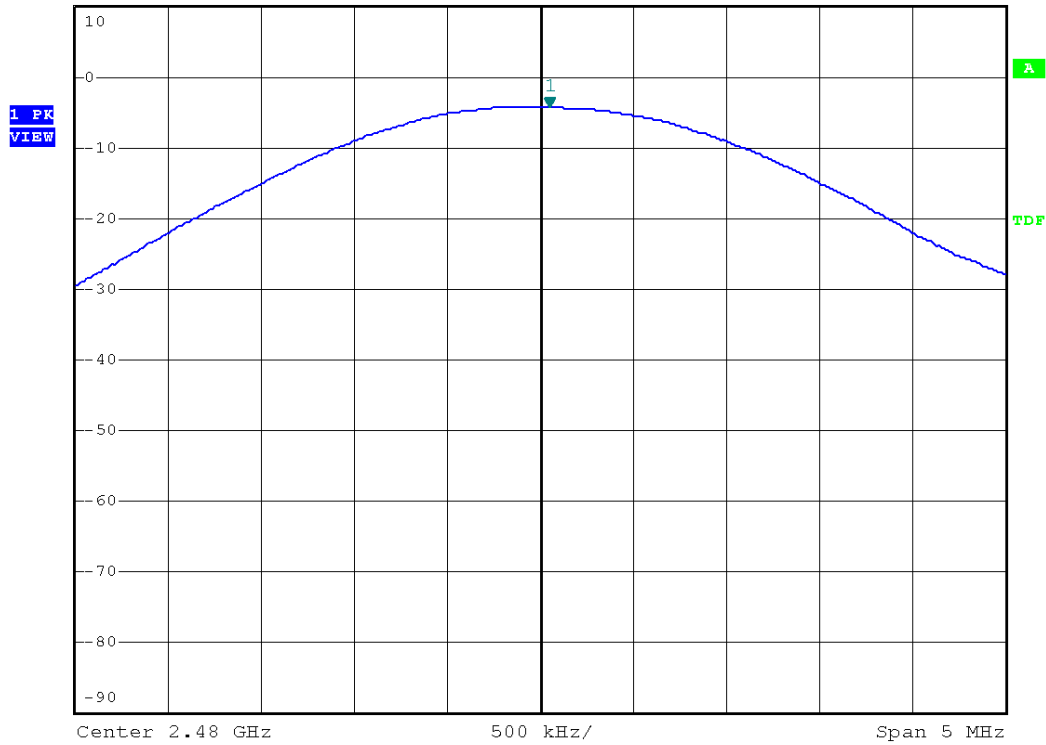



11. Band Edges Measurement

11.1 Test Limit

Below -20dB of the highest emission level of operating band (in 100kHz Resolution Bandwidth).

11.2 Test Procedure :

- a. The transmitter output was connected to the spectrum analyzer via a low lose cable.
- b. Set both RBW and VBW of spectrum analyzer to 100 KHz with convenient frequency span including 100 KHz bandwidth from band edge.
- c. The band edges was measured and recorded.

11.3 Test Setup Layout

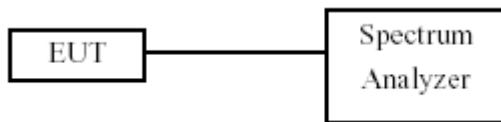

11.4 List of Measuring Equipment Used

Instrument/Ancillary	Model No.	Manufacturer	Serial No.	Calibration Date	Valid Date
Spectrum Analyzer	R&S	FSP40	100047	2011/05/05	2012/05/04



11.5 Test Result and Data

Modulation Standard: GFSK (1Mbps)

Test Date: Jul. 06, 2011

Temperature: 25

Atmospheric pressure: 1020 hPa

Humidity: 65%

Channel	Frequency	maximum value in frequency (MHz)	maximum value is (dBm)
00	2402	2399.92	-43.08
78	2480	2484.46	-48.09

Modulation Standard: $\pi/4$ -DQPSK (2Mbps)

Test Date: Jul. 06, 2011

Temperature: 25

Atmospheric pressure: 1020 hPa

Humidity: 65%

Channel	Frequency	maximum value in frequency (MHz)	maximum value is (dBm)
00	2402	2399.40	-52.97
78	2480	2483.79	-51.15

Modulation Standard: 8DPSK (3Mbps)

Test Date: Jul. 06, 2011

Temperature: 25

Atmospheric pressure: 1020 hPa

Humidity: 65%

Channel	Frequency	maximum value in frequency (MHz)	maximum value is (dBm)
00	2402	2399.60	-52.05
78	2480	2483.58	-51.17



Modulation Standard: GFSK (1Mbps)
Channel: 00

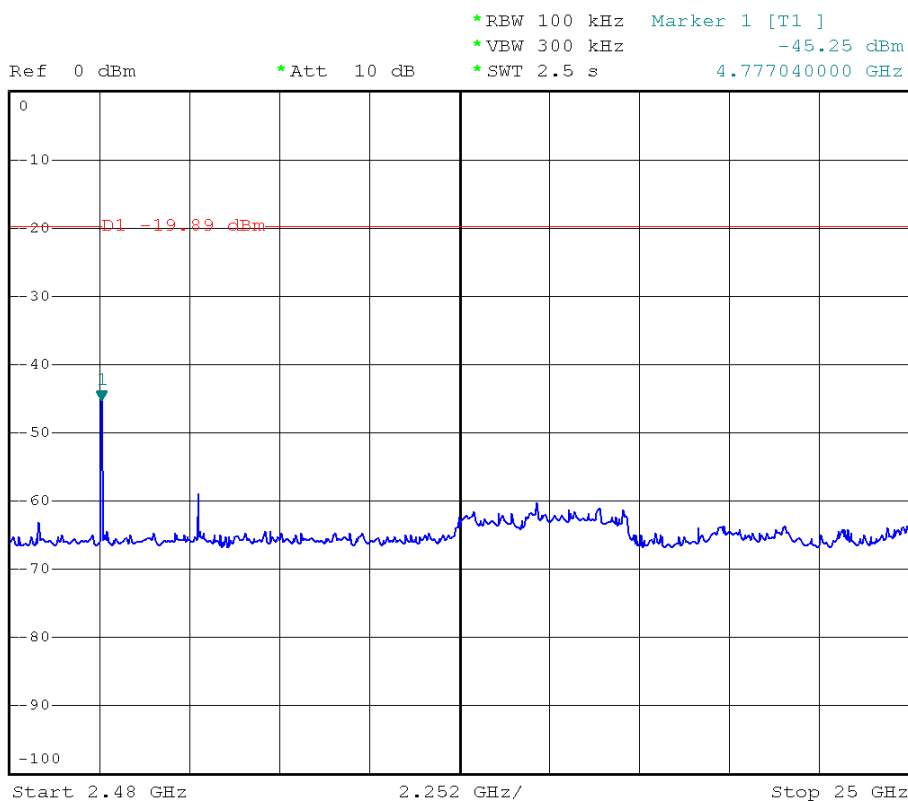
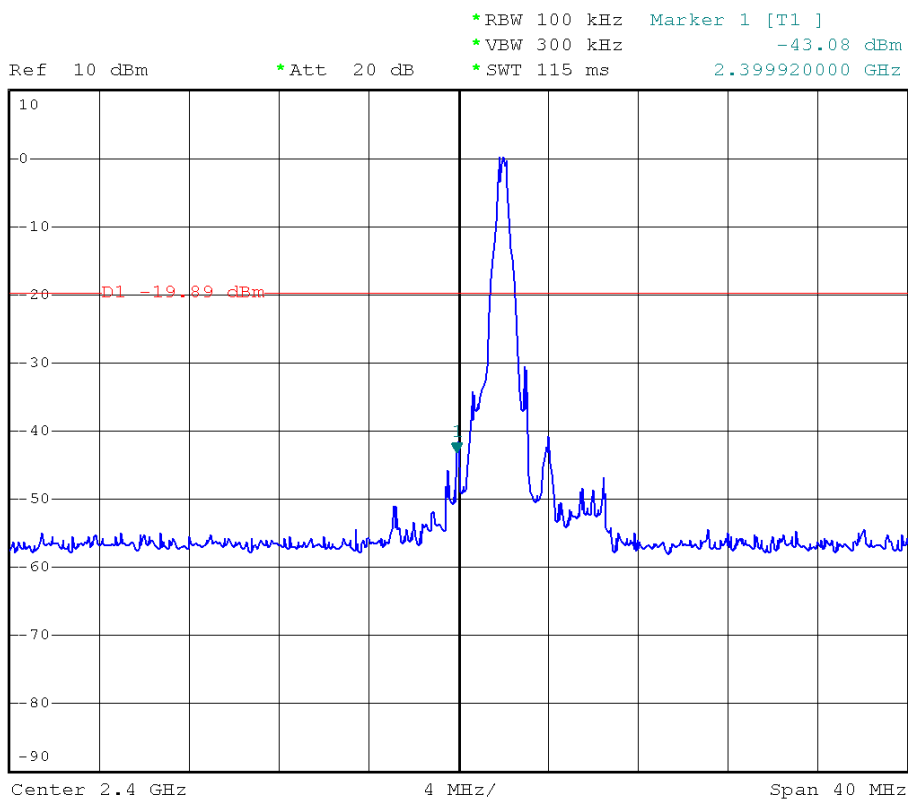



Modulation Standard: GFSK (1Mbps)
Channel: 78



Ref 10 dBm *Att 20 dB *RBW 100 kHz Marker 1 [T1]
*VBW 300 kHz -48.09 dBm
*SWT 115 ms 2.484460000 GHz

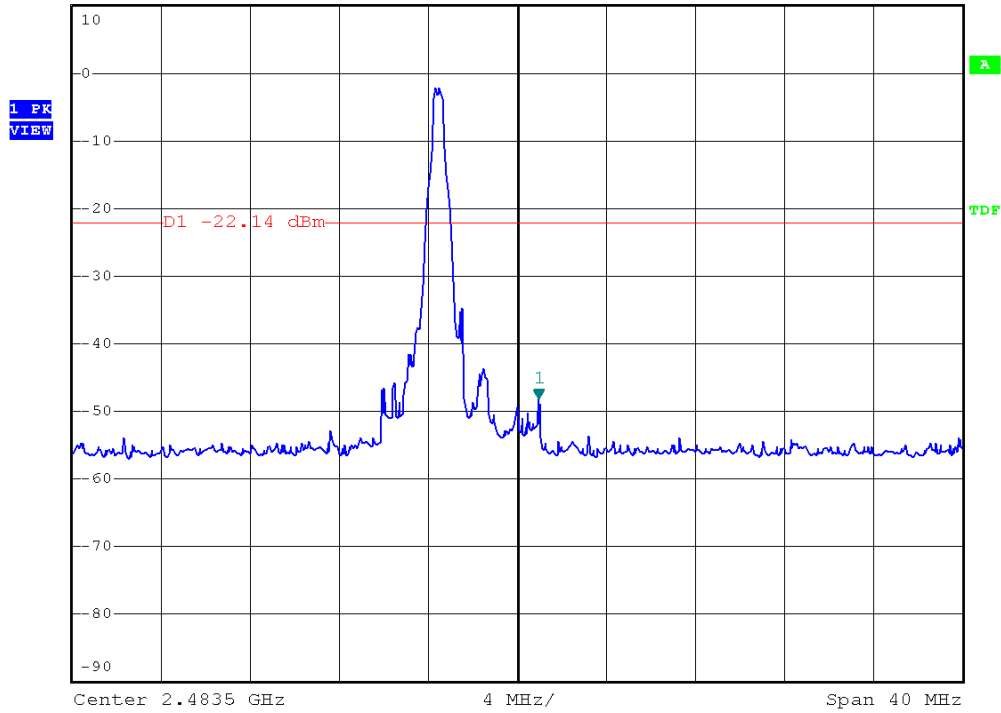

Ref 10 dBm *Att 20 dB *RBW 100 kHz Marker 1 [T1]
*VBW 300 kHz -54.77 dBm
*SWT 2.5 s 2.500000000 GHz

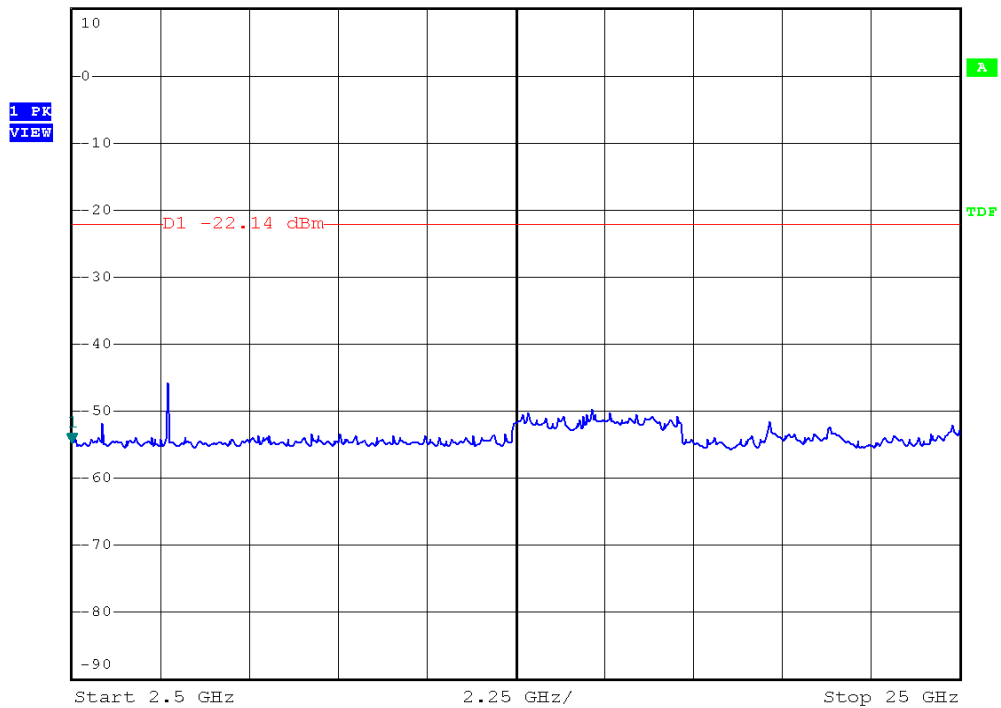



Modulation Standard: $\pi/4$ -DQPSK (2Mbps)
Channel: 00

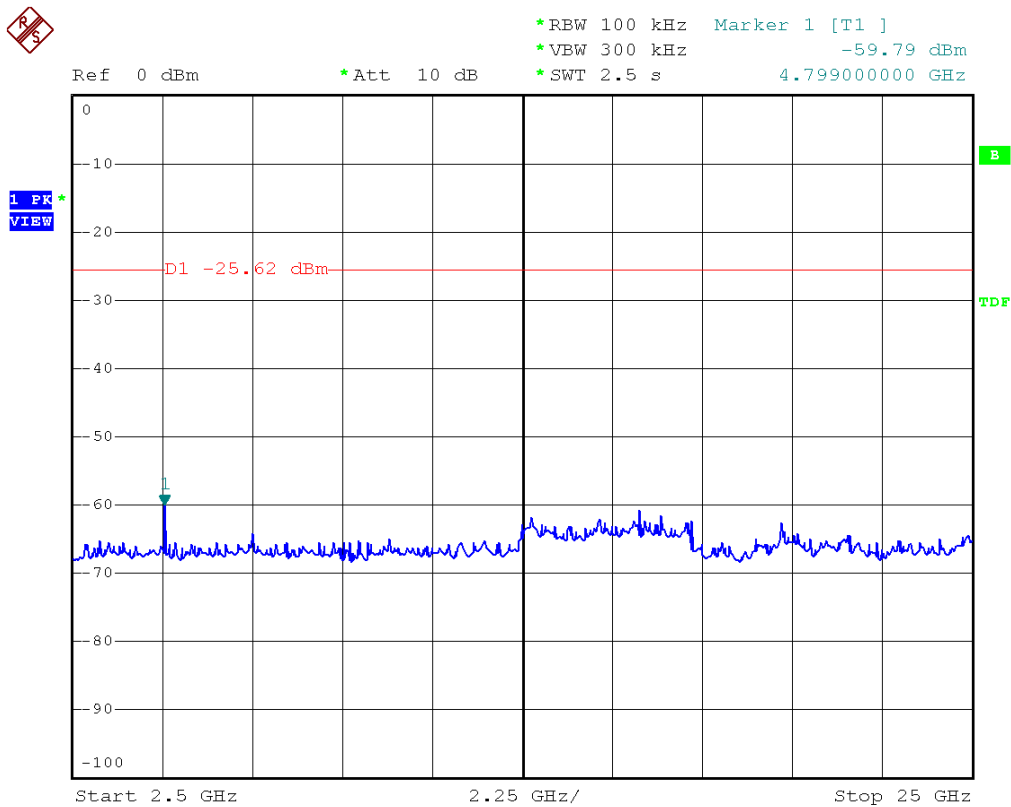
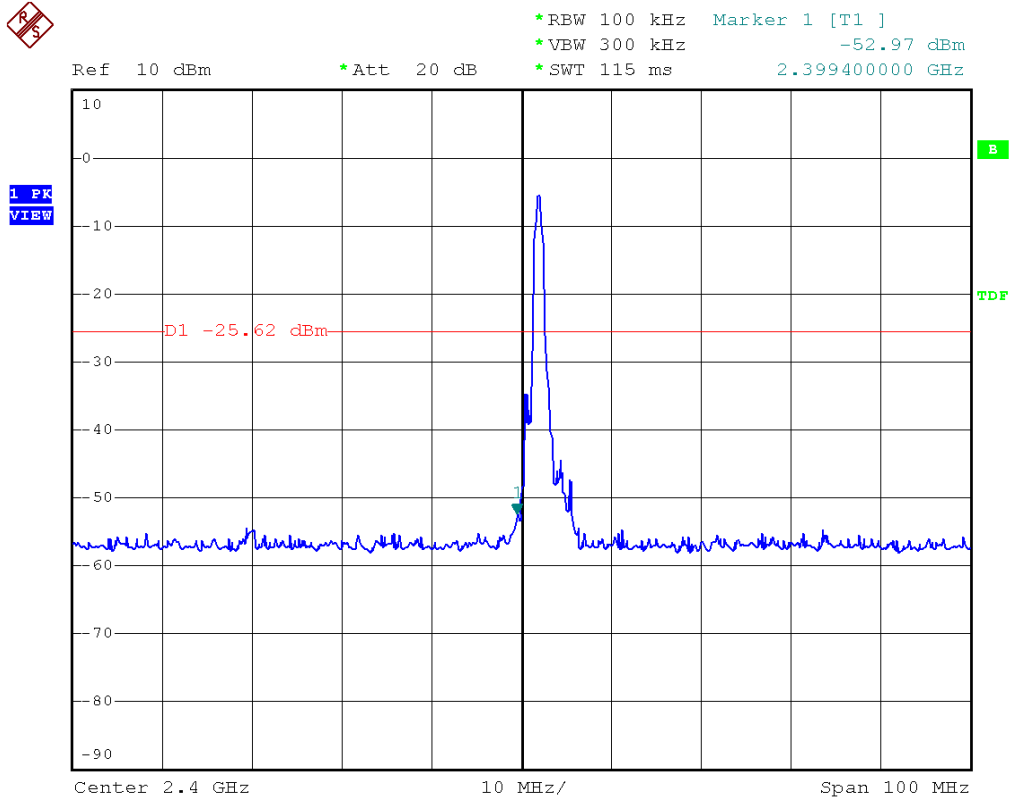



Modulation Standard: $\pi/4$ -DQPSK (2Mbps)
Channel: 78



*RBW 100 kHz Marker 1 [T1]
*VBW 300 kHz -51.15 dBm
*SWT 115 ms 2.483790000 GHz

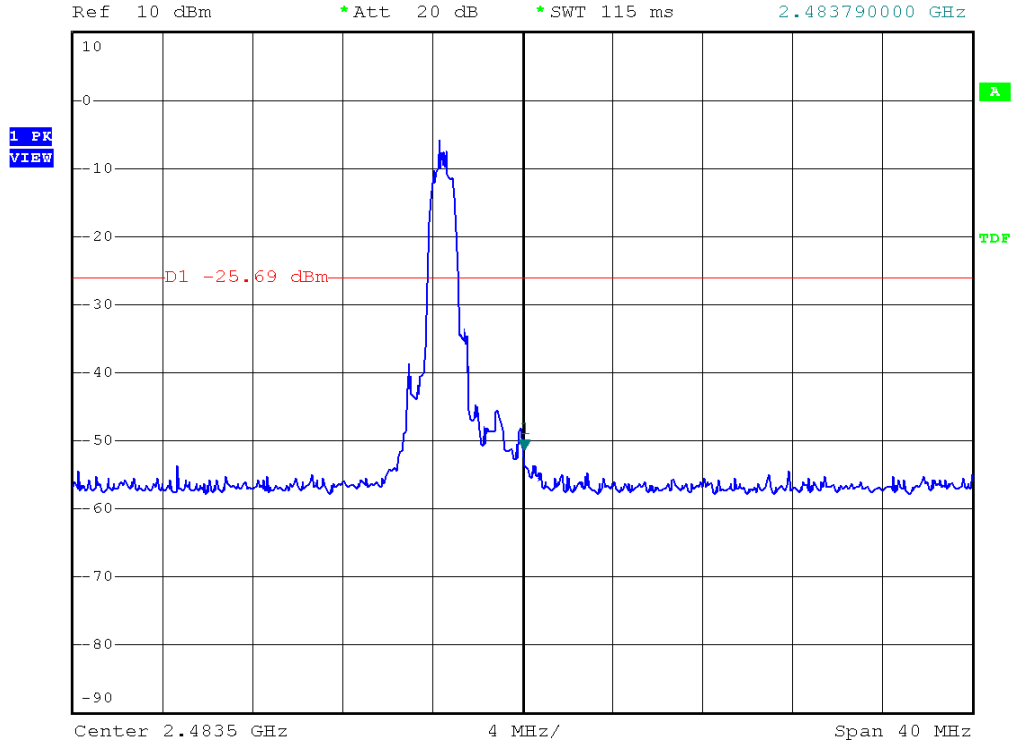

*RBW 100 kHz Marker 1 [T1]
*VBW 300 kHz -60.81 dBm
*SWT 2.5 s 4.979000000 GHz

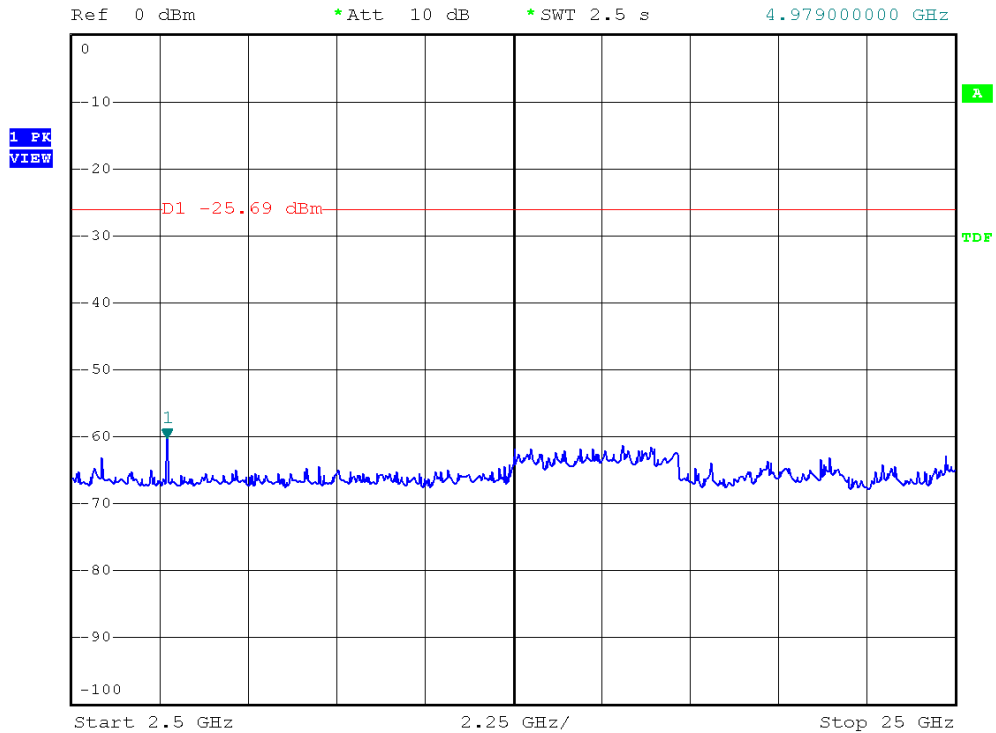



Modulation Standard: 8DPSK (3Mbps)
Channel: 00

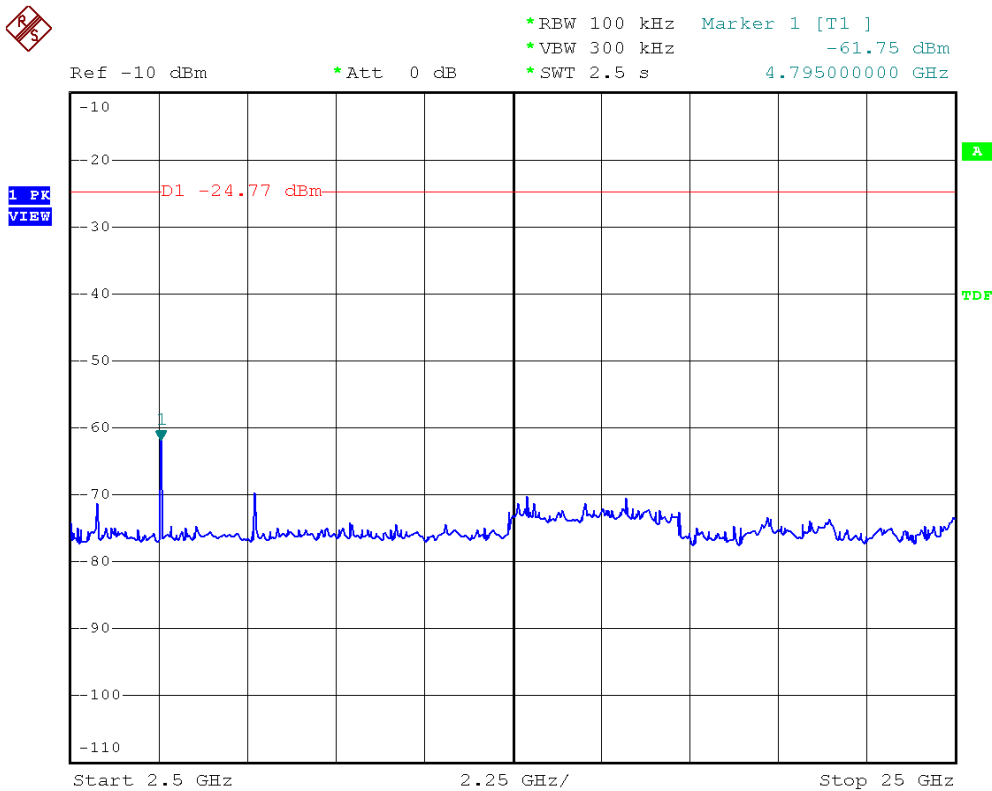
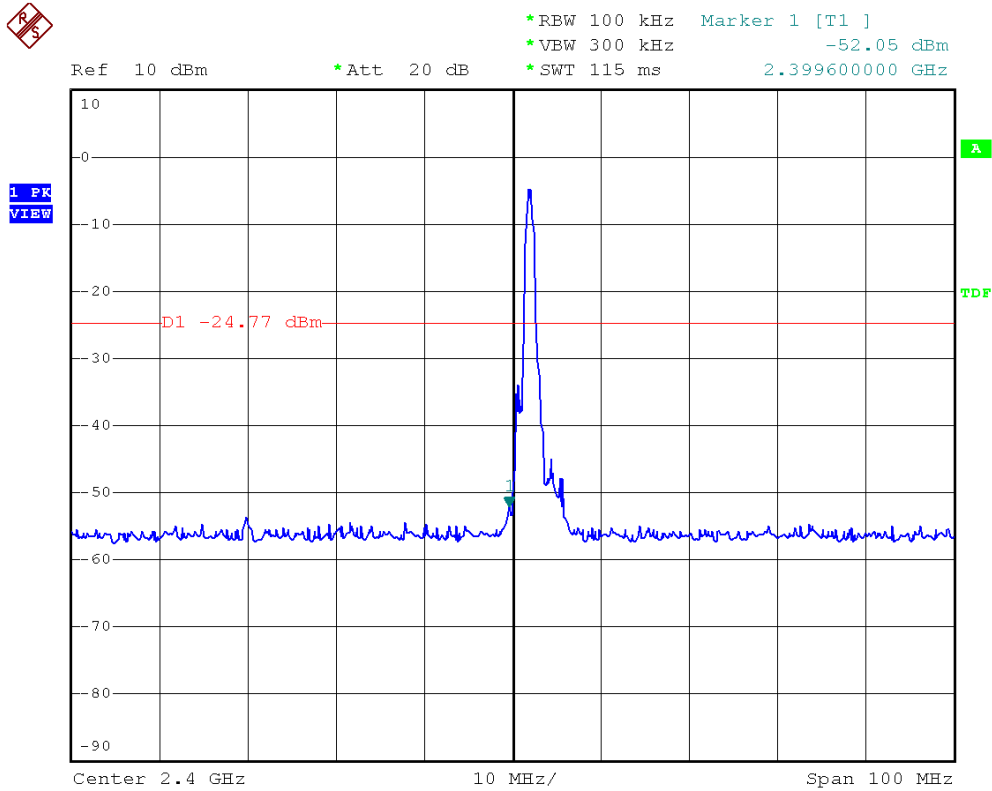



Modulation Standard: 8DPSK (3Mbps)
Channel: 78



*RBW 100 kHz Marker 1 [T1]
*VBW 300 kHz -51.17 dBm
*SWT 115 ms 2.483580000 GHz

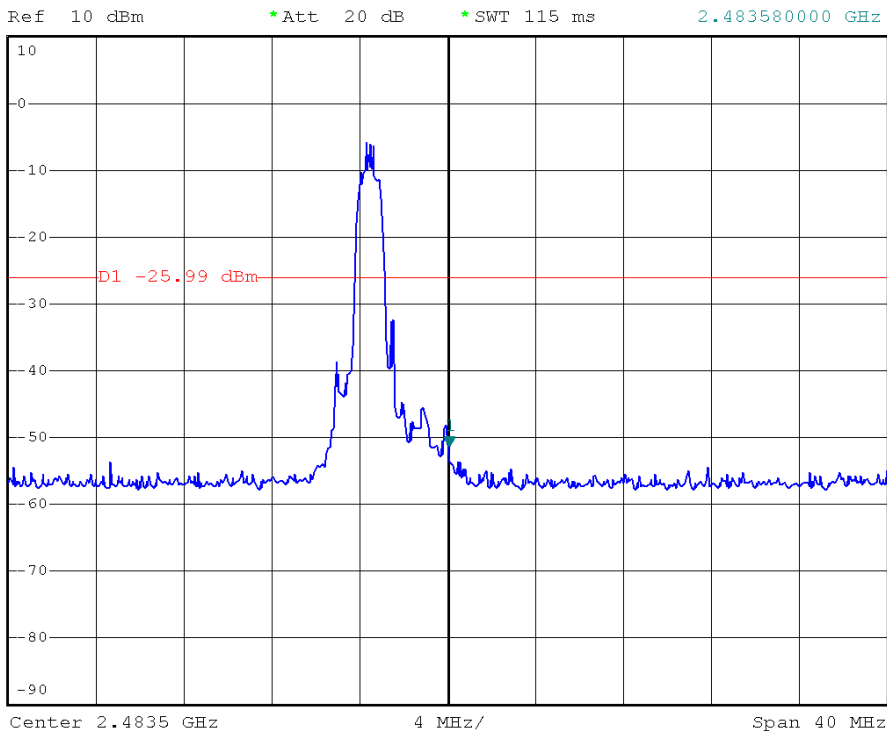

*RBW 100 kHz Marker 1 [T1]
*VBW 300 kHz -60.11 dBm
*SWT 2.5 s 4.930000000 GHz

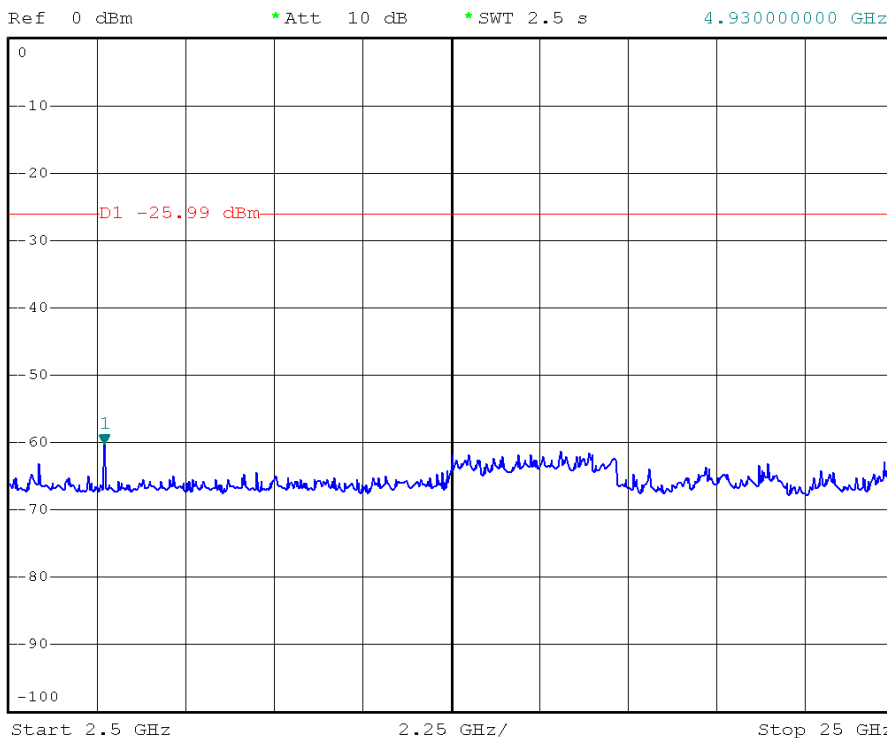

**11.6 Restrict band emission Measurement Data**

Test Date : Jul. 06, 2011
 Temperature : 26
 Humidity : 60%
 Atmospheric Pressure : 1020 hPa
 Modulation Standard : GFSK (1Mbps)
 Adapter : CWT \ KPC-010B

Channel 0						Fundamental Frequency: 2402 MHz				
Frequency (MHz)	Ant-Pol H/V	Meter Reading	Corrected Factor	Result (dBuV/m)	Remark	Limit@3m (dBuV/m)		Margin (dB)	Table (Deg.)	Ant High (m)
						Peak	Ave.			
2385.89	H	54.15	-0.36	53.79	Peak	74	54	-20.21	176	1.00
2385.89	H	40.61	-0.36	40.25	Ave	74	54	-13.75	176	1.00
2385.89	V	51.45	-0.36	51.09	Peak	74	54	-22.91	206	1.50
2385.89	V	39.61	-0.36	39.25	Ave	74	54	-14.75	206	1.50
Channel 78						Fundamental Frequency: 2480 MHz				
2483.58	H	55.64	0.00	55.64	Peak	74	54	-18.36	170	1.21
2483.51	H	40.61	0.00	40.61	Ave	74	54	-13.39	170	1.21
2483.55	V	52.74	0.00	52.74	Peak	74	54	-21.26	176	1.50
2483.51	V	39.46	0.00	39.46	Ave	74	54	-14.54	176	1.50

Test Date : Jul. 06, 2011
 Temperature : 26
 Humidity : 60%
 Atmospheric Pressure : 1020 hPa
 Modulation Standard : GFSK (1Mbps)
 Adapter : Touch \ M8-10US05R

Channel 0						Fundamental Frequency: 2402 MHz				
Frequency (MHz)	Ant-Pol H/V	Meter Reading	Corrected Factor	Result (dBuV/m)	Remark	Limit@3m (dBuV/m)		Margin (dB)	Table (Deg.)	Ant High (m)
						Peak	Ave.			
2386.19	H	53.51	-0.36	53.15	Peak	74	54	-20.85	176	1.00
2386.19	H	40.55	-0.36	40.19	Ave	74	54	-13.81	176	1.00
2385.79	V	52.17	-0.36	51.81	Peak	74	54	-22.19	206	1.50
2385.79	V	39.85	-0.36	39.49	Ave	74	54	-14.51	206	1.50
Channel 78						Fundamental Frequency: 2480 MHz				
2483.55	H	54.72	0.00	54.72	Peak	74	54	-19.28	170	1.21
2483.51	H	40.67	0.00	40.67	Ave	74	54	-13.33	170	1.21
2483.96	V	52.35	0.00	52.35	Peak	74	54	-21.65	176	1.50
2483.96	V	39.42	0.00	39.42	Ave	74	54	-14.58	176	1.50



Test Date : Jul. 06, 2011
 Temperature : 26
 Humidity : 60%
 Atmospheric Pressure : 1020 hPa
 Modulation Standard : $\pi/4$ -DQPSK (2Mbps)
 Adapter : CWT \ KPC-010B

Channel 0						Fundamental Frequency: 2402 MHz				
Frequency (MHz)	Ant-Pol H/V	Meter Reading	Corrected Factor	Result (dBuV/m)	Remark	Limit@3m (dBuV/m)		Margin (dB)	Table (Deg.)	Ant High (m)
						Peak	Ave.			
2385.89	H	52.41	-0.36	52.05	Peak	74	54	-21.95	176	1.00
2385.89	H	45.62	-0.36	45.26	Ave	74	54	-8.74	176	1.00
2385.89	V	51.88	-0.36	51.52	Peak	74	54	-22.48	208	1.50
2385.89	V	43.27	-0.36	42.91	Ave	74	54	-11.09	208	1.50
Channel 78						Fundamental Frequency: 2480 MHz				
2484.00	H	54.54	0.00	54.54	Peak	74	54	-19.46	170	1.21
2483.93	H	46.10	0.00	46.10	Ave	74	54	-7.90	170	1.21
2483.93	V	52.49	0.00	52.49	Peak	74	54	-21.51	176	1.50
2483.93	V	43.42	0.00	43.42	Ave	74	54	-10.68	176	1.50

Test Date : Jul. 06, 2011
 Temperature : 26
 Humidity : 60%
 Atmospheric Pressure : 1020 hPa
 Modulation Standard : $\pi/4$ -DQPSK (2Mbps)
 Adapter : Touch \ M8-10US05R

Channel 0						Fundamental Frequency: 2402 MHz				
Frequency (MHz)	Ant-Pol H/V	Meter Reading	Corrected Factor	Result (dBuV/m)	Remark	Limit@3m (dBuV/m)		Margin (dB)	Table (Deg.)	Ant High (m)
						Peak	Ave.			
2386.30	H	52.02	-0.36	51.66	Peak	74	54	-22.34	176	1.00
2386.30	H	45.58	-0.36	45.22	Ave	74	54	-8.78	176	1.00
2385.79	V	52.38	-0.36	52.02	Peak	74	54	-21.98	208	1.50
2385.79	V	43.51	-0.36	43.15	Ave	74	54	-10.35	208	1.50
Channel 78						Fundamental Frequency: 2480 MHz				
2484.15	H	53.83	0.01	53.84	Peak	74	54	-20.16	170	1.21
2484.15	H	46.12	0.01	46.13	Ave	74	54	-7.87	170	1.21
2483.55	V	52.81	0.00	52.81	Peak	74	54	-21.19	176	1.50
2483.55	V	43.48	0.00	43.48	Ave	74	54	-10.52	176	1.50



Test Date : Jul. 06, 2011
 Temperature : 26
 Humidity : 60%
 Atmospheric Pressure : 1020 hPa
 Modulation Standard : 8DPSK (3Mbps)
 Adapter : CWT \ KPC-010B

Channel 0						Fundamental Frequency: 2402 MHz				
Frequency (MHz)	Ant-Pol H/V	Meter Reading	Corrected Factor	Result (dBuV/m)	Remark	Limit@3m (dBuV/m)		Margin (dB)	Table (Deg.)	Ant High (m)
						Peak	Ave.			
2385.89	H	52.15	-0.36	51.79	Peak	74	54	-22.21	176	1.00
2385.89	H	45.69	-0.36	45.33	Ave	74	54	-8.67	176	1.00
2385.89	V	51.77	-0.36	51.41	Peak	74	54	-22.59	207	1.50
2385.89	V	43.87	-0.36	43.51	Ave	74	54	-10.49	207	1.50
Channel 78						Fundamental Frequency: 2480 MHz				
2483.81	H	55.74	0.00	55.74	Peak	74	54	-18.26	170	1.21
2483.93	H	48.38	0.00	48.38	Ave	74	54	-5.62	170	1.21
2484.00	V	54.69	0.00	54.69	Peak	74	54	-19.31	176	1.50
2483.93	V	45.72	0.00	45.72	Ave	74	54	-8.28	176	1.50

Test Date : Jul. 06, 2011
 Temperature : 26
 Humidity : 60%
 Atmospheric Pressure : 1020 hPa
 Modulation Standard : 8DPSK (3Mbps)
 Adapter : Touch \ M8-10US05R

Channel 0						Fundamental Frequency: 2402 MHz				
Frequency (MHz)	Ant-Pol H/V	Meter Reading	Corrected Factor	Result (dBuV/m)	Remark	Limit@3m (dBuV/m)		Margin (dB)	Table (Deg.)	Ant High (m)
						Peak	Ave.			
2385.89	H	53.12	-0.36	52.76	Peak	74	54	-21.24	176	1.00
2385.89	H	45.77	-0.36	45.41	Ave	74	54	-8.59	176	1.00
2385.79	V	52.08	-0.36	51.72	Peak	74	54	-22.28	207	1.50
2385.79	V	43.88	-0.36	43.52	Ave	74	54	-10.48	207	1.50
Channel 78						Fundamental Frequency: 2480 MHz				
2483.89	H	56.59	0.00	56.59	Peak	74	54	-17.41	170	1.21
2483.89	H	48.48	0.00	48.48	Ave	74	54	-5.52	170	1.21
2484.08	V	54.00	0.00	54.00	Peak	74	54	-20.00	176	1.50
2484.08	V	45.87	0.00	45.87	Ave	74	54	-8.22	176	1.50



Notes:

1. Result = Meter Reading + Factor
2. Factor = Antenna Factor + Cable Loss – Amplifier
3. The resolution bandwidth of test receiver/spectrum analyzer is 1 MHz and video bandwidth is 3 MHz for Peak detection at frequency above 1GHz.
4. The resolution bandwidth of test receiver/spectrum analyzer is 1MHz and video bandwidth is 10Hz for Average detection at frequency above 1GHz

12. Restricted Bands of Operation

Only spurious emissions are permitted in any of the frequency bands listed below:

MHz	MHz	MHz	GHz
0.09000 – 0.11000	16.42000 – 16.42300	399.9 – 410.0	4.500 – 5.250
0.49500 – 0.505**	16.69475 – 16.69525	608.0 – 614.0	5.350 – 5.460
2.17350 – 2.19050	16.80425 – 16.80475	960.0 – 1240.0	7.250 – 7.750
4.12500 – 4.12800	25.50000 – 25.67000	1300.0 – 1427.0	8.025 – 8.500
4.17725 – 4.17775	37.50000 – 38.25000	1435.0 – 1626.5	9.000 – 9.200
4.20725 – 4.20775	73.00000 – 74.60000	1645.5 – 1646.5	9.300 – 9.500
6.21500 – 6.21800	74.80000 – 75.20000	1660.0 – 1710.0	10.600 – 12.700
6.26775 – 6.26825	108.00000 – 121.94000	1718.8 – 1722.2	13.250 – 13.400
6.31175 – 6.31225	123.00000 – 138.00000	2200.0 – 2300.0	14.470 – 14.500
8.29100 – 8.29400	149.90000 – 150.05000	2310.0 – 2390.0	15.350 – 16.200
8.36200 – 8.36600	156.52475 – 156.52525	2483.5 – 2500.0	17.700 – 21.400
8.37625 – 8.38675	156.70000 – 156.90000	2655.0 – 2900.0	22.010 – 23.120
8.41425 – 8.41475	162.01250 – 167.17000	3260.0 – 3267.0	23.600 – 24.000
12.29000 – 12.29300	167.72000 – 173.20000	3332.0 – 3339.0	31.200 – 31.800
12.51975 – 12.52025	240.00000 – 285.00000	3345.8 – 3358.0	36.430 – 36.500
12.57675 – 12.57725	322.00000 – 335.40000	3600.0 – 4400.0	Above 38.6
13.36000 – 13.41000			

** : Until February 1, 1999, this restricted band shall be 0.490-0.510 MHz

12.1 Labeling Requirement

The device shall bear the following statement in a conspicuous location on the device:

This device complies with part 15 of the FCC Rules. Operation is subject to the following two conditions: (1) This device may not cause harmful interference, and (2) this device must accept any interference received, including interference that may cause undesired operation.