

# **TEST REPORT**

of

## **FCC Part 15 Subpart C**

Product : **Mifare USB Reader**

Model(s): **MD-150M**

Applicant: **Partner Tech Corp.**

Address: **10F, No. 233-2, Pao Chiao Rd.,  
Shin Tien, Taipei,  
Taiwan**

Test Performed by:

### **International Standards Laboratory**

<Lung-Tan LAB>

\*Site Registration No.

BSMI: SL2-IN-E-0013; TAF: 0997; IC: IC4067B-1;

VCCI: R-1435, C-1440, T-299, R-2598, C-2845; NEMKO: ELA 113B

\*Address:

No. 120, Lane 180, San Ho Tsuen, Hsin Ho Rd.

Lung-Tan Hsiang, Tao Yuan County 325, Taiwan

\*Tel : 886-3-407-1718; Fax: 886-3-407-1738

Report No.: **ISL-09LR022FC**

Issue Date : **2009/08/31**

## Contents of Report

1.	General .....	1
1.1	Certification of Accuracy of Test Data .....	1
1.2	Test Results Summary .....	2
2.	Description of Equipment Under Test (EUT) .....	3
3.	Description of Support Equipment.....	4
3.1	Description of Support Equipment .....	4
3.2	Software for Controlling Support Unit.....	4
3.3	I/O Cable Condition of EUT and Support Units .....	4
4.	TEST RESULTS .....	5
4.1	Powerline Conducted Emissions [Section 15.207] .....	5
4.1.1	EUT Configuration .....	5
4.1.2	Test Procedure .....	5
4.1.3	EMI Receiver/Spectrum Analyzer Configuration (for the frequencies tested).....	5
4.1.4	Test Data:.....	6
4.2	Radiated Emission Measurement [Section [15.225(a)(b)(c)(d)]].....	8
4.2.1	EUT Configuration .....	8
4.2.2	Test Procedure .....	8
4.2.3	EMI Receiver/Spectrum Analyzer Configuration (for the frequencies tested).....	8
4.2.4	Radiated Emission Limit .....	9
4.2.5	Test Data (Radiated of Fundamental Emission) .....	10
4.2.6	Test Data(Band Edge measurement)(X axis) .....	11
4.2.7	Test Data (RADIATED OF SPURIOUS EMISSION)(9KHz – 1GHz):.....	14
4.3	Frequency Stability Measurement.....	17
7.1.1.	Limits of Frequency Stability Measurement.....	17
7.1.2.	Test Procedure .....	17
7.1.3.	Test Setup .....	17
4.3.1	Test Data.....	18
4.4	Occupied bandwidth measurements [ANSI C63.4 section 13.1.7] .....	20
4.4.1	Test Procedure .....	20
4.4.2	Test Setup .....	20
4.4.3	Test Data:.....	20
5.	Appendix .....	21
5.1	Appendix A: Measurement Procedure for Power line Conducted Emissions.....	21
5.2	Appendix B: Test Procedure for Radiated Emissions .....	22
5.3	Appendix C: Test Equipment .....	23
5.3.1	Test Equipment List.....	23
5.3.2	Software for Controlling Spectrum/Receiver and Calculating Test Data .....	23
5.4	Appendix D: Layout of EUT and Support Equipment.....	24
5.4.1	General Conducted Test Configuration .....	24
5.4.2	General Radiation Test Configuration.....	25
5.5	Appendix E: Accuracy of Measurement .....	27
5.6	Appendix F: Photographs of EUT Configuration Test Set Up.....	28
5.7	Appendix G: Photographs of EUT .....	31

## 1. General

### 1.1 Certification of Accuracy of Test Data

**Standards:** CFR 47 Part 15 Subpart C (Section 15.225)

**Test Procedure:** ANSI C63.4:2003

**Equipment Tested:** Mifare USB Reader

**Model:** MD-150M

**Applied by:** **Partner Tech Corp.**

**Sample received Date:** 2009/08/18

**Final test Date :** 2009/08/18-2009/08/29

**Test Result** PASS

**Test Site:** Chamber 12, Chamber 14, Conduction 02

**Temperature** Refer to each site test data

**Humidity:** Refer to each site test data

**Test Engineer:**

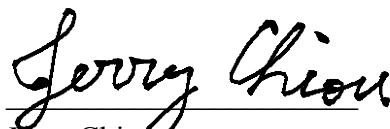
  
Jerry Chiou

All the tests in this report have been performed and recorded in accordance with the standards described above and performed by an independent electromagnetic compatibility consultant, International Standards Laboratory.

The test results contained in this report accurately represent the measurements of the characteristics and the energy generated by sample equipment under test at the time of the test. The sample equipment tested as described in this report is in compliance with the limits of above standards.



Jim Chu/ Director

Test results given in this report apply only to the specific sample(s) tested under stated test conditions.

This report shall not be reproduced other than in full without the explicit written consent of ISL.

This report totally contains 37 pages, including 1 cover page, 1 contents page, and 35 pages for the test description.

This report must not be used to claim product endorsement by NVLAP or any agency of the U.S. Government.

This test data shown below is traceable to NIST or national or international standard.

International Standards Laboratory certifies that no party to this application has been denied the FCC benefits pursuant to Section 5301 of the Anti-Drug Abuse Act of 1988, 21 U.S.C. 853(a).

## 1.2 Test Results Summary

The RFID functions of EUT has been tested according to the FCC regulations listed below:

Tested Standards: 47 CFR Part 15 Subpart C			
Standard Section	Test Type	Result	Remarks
15.207	AC Power Line Emissions	Pass	
15.225(a)(b)(c)	Peak Output Power	Pass	
15.225(d)	Radiated Emissions	Pass	
15.225(d)	Band Edge Measurement	Pass	
15.225(e)	Frequency Stability	Pass	

## 2. Description of Equipment Under Test (EUT)

### EUT

Description: Mifare USB Reader  
Model No.: MD-150M

RFID module: Sunion(Model: MD150M-P)  
Frequency Range: 13.56 MHz  
Support channel: 1 Channel  
Modulation Skill: ASK  
Antennas Type: Loop  
Antenna Connected: Printed on PCB.  
Power Type of wireless module: 5V DC from EUT  
The channel and the operation frequency is listed below:  
Channel Frequency (MHz)  
01 13.56

The RFID module reads/writes the RFID pre-paid card to assist the work of cashier.

#### The EUT was built in a POS Terminal as following:

Description: POS Terminal  
Condition: Pre-Production  
Model: PT-62XXXX(C can be 0-9, A-Z or BLANK))  
Serial Number: N/A  
Power Supply Type: Power adapter (100-240Vac~, 12V/12.5A)  
FSP (Model: FSP150-AHAN1)  
Hard Disk Driver: Seagate SATA (Model: ST380815AS) 80G or  
Seagate SATA (Model: ST3160318AS) 160G or  
Western Digital SATA (Model: WD1600AAJS) 160G

IO port:  
Keyboard Connector: one 6-pins  
Serial Port: four 9-pins  
USB Connector: four 4-pins  
VGA Connector: one 15-pins  
Cash drawer Connector: one 6-pins  
LAN Port: one 8-pins (10/100/1000Mbps)  
Memory: DDR2 512MB (up to 2G)  
LCD panel: 12.1" Hydis (Model: HT121X01-300)  
VGA tested Resolution: 1024 X 768

### 3. Description of Support Equipment

#### 3.1 Description of Support Equipment

Unit	Model Serial No.	Brand	Power Cord	FCC ID
Keyboard	SK-8110, S/N: MY-05N456-38843-2BK-3315	DELL	N/A	FCC DOC
Mouse	MO71KC S/N: 511092011	DELL	N/A	FCC DOC

#### 3.2 Software for Controlling Support Unit

Test programs exercising various part of EUT were used. The programs were executed as follows:

- A. Read and write to the disk drives.
- B. The RF software makes the tranceiver continuously sending and receiving RF signals
- C. Repeat the above steps.

	Filename	Issued Date
RFID	MD_150M.exe	12/23/2008

#### 3.3 I/O Cable Condition of EUT and Support Units

Description	Path	Cable Length	Cable Type	Connector Type
AC Power Cord	110V (~240V) to AC Power Cord Inlet (3-pin)	1.8M	Non-shielded, Detachable	Plastic Head
USB Mouse Data Cable	USB Mouse to EUT USB Port	1.8M	Shielded, Un-detachable	Metal Head
USB Keyboard Data Cable	USB Keyboard to EUT USB Port	1.8M	Shielded, Un-detachable	Metal Head

## 4. TEST RESULTS

### 4.1 Powerline Conducted Emissions [Section 15.207]

#### 4.1.1 EUT Configuration

The EUT was set up on the non-conductive table that is 1.0 by 1.5 meter, 80cm above ground. The wall of the shielded room was located 40cm to the rear of the EUT.

Power to the EUT was provided through the LISN. The impedance vs. frequency characteristic of the LISN is complied with the limit used.

Both lines (neutral and hot) were connected to the LISN in series at testing. A coaxial-type connector which provides one 50 ohms terminating impedance was provided for connecting the test instrument. The excess length of the power cord was folded back and forth at the center of the lead so as to form a bundle not exceeding 40cm in length.

Any changes made to the configuration, or modifications made to the EUT, during testing are noted in the following test record.

If the EUT is a Personal Computer or a peripheral of personal computer, and the personal computer has an auxiliary AC outlet which can be used for providing power to an external monitor, then all measurements will be made with the monitor power from first the computer-mounted AC outlet and then a floor-mounted AC outlet.

#### 4.1.2 Test Procedure

The system was set up as described above, with the EMI diagnostic software running. The main power line conducted EMI tests were run on the hot and neutral conductors of the power cord and the results were recorded. The effect of varying the position of the interface cables has been investigated to find the configuration that produces maximum emission.

At the frequencies where the peak values of the emissions were higher than 6dB below the applicable limits, the emissions were also measured with the quasi-peak detectors. At the frequencies where the quasi-peak values of the emissions were higher than 6dB below the applicable average limits, the emissions were also measured with the average detectors.

The highest emissions were analyzed in details by operating the spectrum analyzer in fixed tuned mode to determine the nature of the emissions and to provide information which could be useful in reducing their amplitude.

Powerline Conducted Emissions Test Mode:

1. Transmitter with antenna
2. Transmitter with 50ohm dummy load.

#### 4.1.3 EMI Receiver/Spectrum Analyzer Configuration (for the frequencies tested)

Frequency Range	150 KHz--30MHz
Detector Function	Quasi-Peak/Average
Bandwidth (RBW)	9KHz

4.1.4 Test Data:

Power Line Conducted Emissions (Hot)

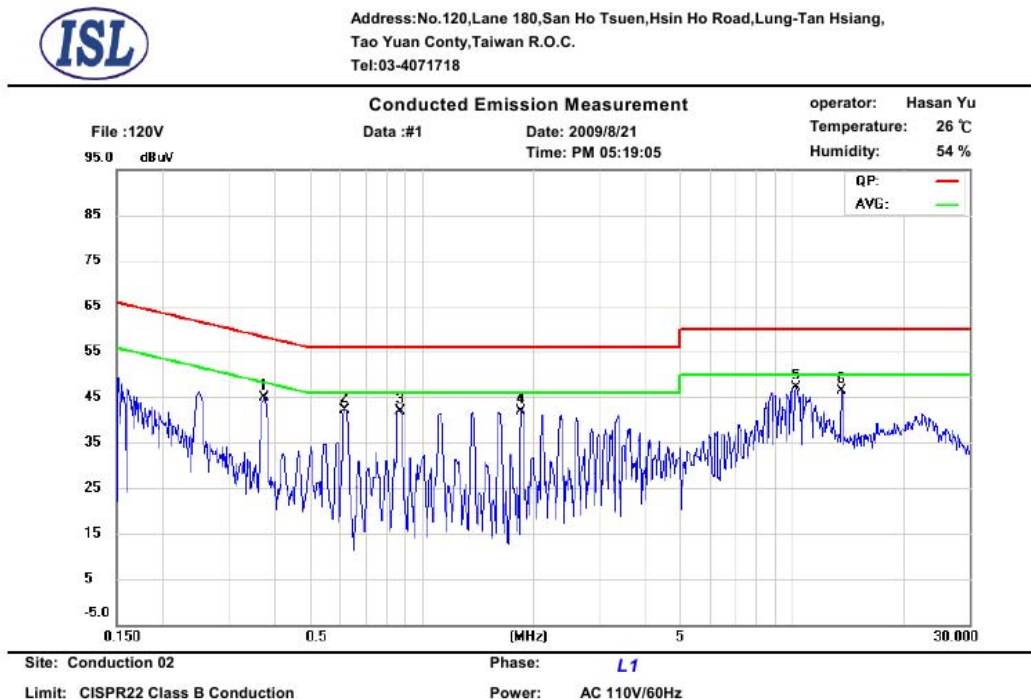

No.	Frequency MHz	LISN Loss dB	Cable Loss dB	QP Correct. dBuV	QP Limit dBuV	QP Margin dB	AVG Correct. dBuV	AVG Limit dBuV	AVG Margin dB	Note
1	0.3724	0.18	0.01	43.80	58.4	-14.6	42.94	48.4	-5.51	
2	0.6206	0.19	0.02	41.54	56.0	-14.4	38.79	46.0	-7.21	
3	0.8665	0.2	0.03	41.03	56.0	-14.9	36.25	46.0	-9.75	
4	1.8500	0.24	0.05	40.75	56.0	-15.2	31.13	46.0	-14.8	
5	10.2250	0.45	0.12	39.37	60.0	-20.6	29.80	50.0	-20.2	
6	13.5500	0.54	0.13	35.87	60.0	-24.1	26.17	50.0	-23.8	



### Power Line Conducted Emissions (Neutral)



Address: No.120, Lane 180, San Ho Tsuen, Hsin Ho Road, Lung-Tan Hsiang,  
Tao Yuan Conty, Taiwan R.O.C.  
Tel: 03-4071718

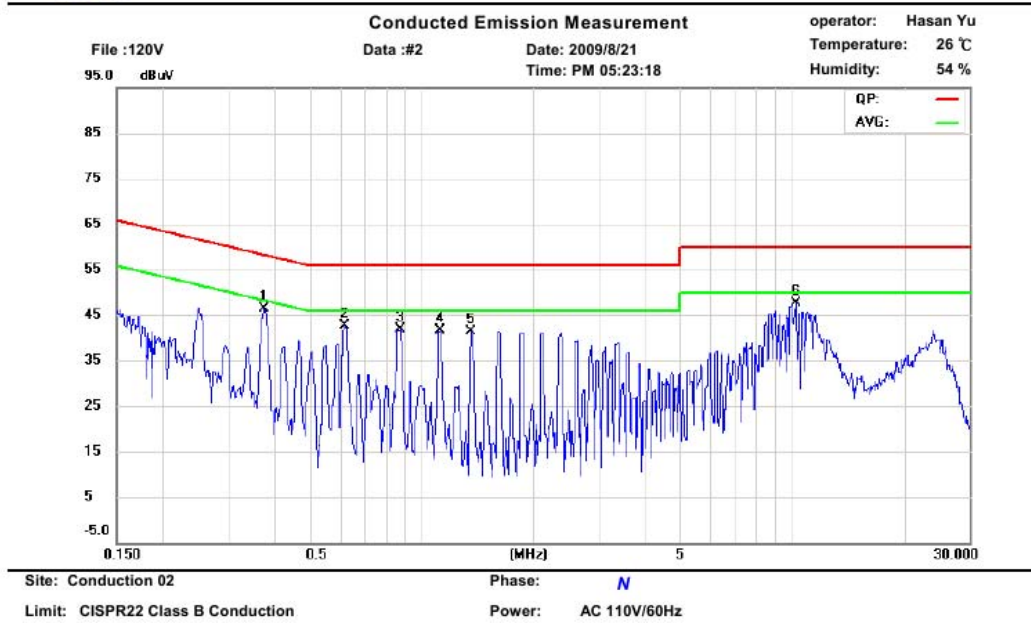

No.	Frequency MHz	LISN Loss dB	Cable Loss dB	QP Correct. dBuV	QP Limit dBuV	QP Margin dB	AVG Correct. dBuV	AVG Limit dBuV	AVG Margin dB	Note
1	0.3725	0.15	0.01	44.44	58.4	-14.0	43.35	48.4	-5.09	
2	0.6206	0.16	0.02	41.72	56.0	-14.2	39.56	46.0	-6.44	
3	0.8690	0.17	0.03	41.06	56.0	-14.9	36.51	46.0	-9.49	
4	1.1210	0.18	0.03	41.00	56.0	-15.0	33.14	46.0	-12.8	
5	1.3587	0.19	0.04	40.69	56.0	-15.3	32.28	46.0	-13.7	
6	10.2060	0.37	0.12	46.62	60.0	-13.3	30.71	50.0	-19.2	

\* NOTE: Margin = Amplitude + Insertion Loss - Limit  
 A margin of -8dB means that the emission is 8dB below the limit

## 4.2 Radiated Emission Measurement [Section [15.225(a)(b)(c)(d)]]

### 4.2.1 EUT Configuration

The equipment under test was set up on the 10 meter chamber with measurement distance of 3 and 10 meters. The EUT was placed on a non-conductive table 80cm above ground. Any changes made to the configuration, or modifications made to the EUT, during testing are noted in the following test record.

### 4.2.2 Test Procedure

The system was set up as described above, with the EMI diagnostic software running. We found the maximum readings by varying the height of antenna and then rotating the turntable. Both polarization of antenna, horizontal and vertical, are measured.

30M to 1GHz: The highest emissions between 30 MHz to 1000 MHz were also analyzed in details by operating the spectrum analyzer and/or EMI receiver in quasi-peak mode to determine the precise amplitude of the emissions. While doing so, the interconnecting cables and major parts of the system were moved around, the antenna height was varied between one and four meters, its polarization was varied between vertical and horizontal, and the turntable was slowly rotated, to maximize the emission.

For the test of 2<sup>nd</sup> to 10<sup>th</sup> harmonics frequencies, the equipment setup was also refer to EMI Receiver/Spectrum Analyzer Configuration. The frequencies were tested using Peak mode first, if the test data is higher than the emissions limit, an additional measurement using Average mode will be performed and the average reading will be compared to the limit and record in test report.

### 4.2.3 EMI Receiver/Spectrum Analyzer Configuration (for the frequencies tested)

#### RADIATED OF FUNDAMENTAL EMISSION

Frequency Range Tested:	13.56MHz
Detector Function:	Peak Mode
Resolution Bandwidth (RBW):	10KHz
Video Bandwidth (VBW)	100KHz
Measurement distance	3m and 10m

#### BAND EDGE

Frequency Range Tested:	13.11 MHz ~14.01MHz
Detector Function:	Peak Mode
Resolution Bandwidth (RBW):	10KHz
Video Bandwidth (VBW)	100KHz
Measurement distance	3m and 10m

#### RADIATED OF SPURIOUS EMISSION

Frequency Range Tested:	9KHz~30MHz
Detector Function:	Peak Mode
Resolution Bandwidth (RBW):	10KHz
Video Bandwidth (VBW)	100KHz
Measurement distance	3m and 10m

Frequency Range Tested:	30MHz~1000MHz
Detector Function:	Quasi-Peak Mode
Resolution Bandwidth (RBW):	120KHz
Video Bandwidth (VBW)	360KHz
Measurement distance	3m

#### 4.2.4 Radiated Emission Limit

##### FCC 15.225 Fundamental Emission Limits

Frequency MHz	Distance Meter	Field Strength of Fundamental	
		$\mu\text{V/m}$	$\text{dB}\mu\text{V/m}$
13.110 – 13.410	30	106	40.5
13.410 – 13.553	30	334	50.4
<b>13.553 – 13.567</b>	<b>30</b>	<b>15848</b>	<b>84</b>
13.567 – 13.710	30	334	50.4
13.710 – 14.010	30	106	40.5

Note: RF Voltage ( $\text{dB}\mu\text{V/m}$ ) =  $20 \log$  RF Voltage ( $\mu\text{V/m}$ )

Limit Conversion:  
FCC section 15.209

Frequency (MHz)	Field Strength (microvolts / meter)	Measurement Distance (meters)
1.705~30	30	30

Ex: Limit of 13.11 MHz  
 $30(\text{ microvolts / meter}) = 20 * \log(30) \text{dB}\mu\text{V/m} = 29.54 \text{ dB}\mu\text{V/m}$

If  $D1=30, D2=10$   
 $L2 = L1(D1/D2)$   
 $L2 = 29.54 + 40 \log(D1/D2) = 48.63 \text{ (dB}\mu\text{V/m)}$

4.2.5 Test Data (Radiated of Fundamental Emission)

**Radiated of Fundamental Emission**

Measurement Distance 10m

Mode	Frequency	Rx Amp.	Correction Factor	Correct. Emi.	Limit	Margin	Antenna Polarization
axis	MHz	(dBuV)	(dB)	(dBuV/m)	(dBuV/m)	(dB)	
X	13.56	25.07	7.8	32.87	103.08	-70.21	H
X	13.56	23.72	7.8	31.52	103.08	-71.56	V
Y	13.56	25.39	7.8	33.19	103.08	-69.89	H
Y	13.56	23.46	7.8	31.26	103.08	-71.82	V
Z	13.56	24.76	7.8	32.56	103.08	-70.52	H
Z	13.56	<b>26.27</b>	7.8	34.07	103.08	-69.01	V

Measurement Distance 3m

Mode	Frequency	Rx Amp.	Correction Factor	Correct. Emi.	Limit	Margin	Antenna Polarization
axis	MHz	(dBuV)	(dB)	(dBuV/m)	(dBuV/m)	(dB)	
X	13.56	39.27	7.8	47.07	124	-76.93	H
X	13.56	<b>44.56</b>	7.8	52.36	124	-71.64	V
Y	13.56	36.52	7.8	44.32	124	-79.68	H
Y	13.56	43.34	7.8	51.14	124	-72.86	V
Z	13.56	44.08	7.8	51.88	124	-72.12	H
Z	13.56	39.97	7.8	47.77	124	-76.23	V

#### 4.2.6 Test Data(Band Edge measurement)(X axis)

Measurement Distance 10m

Frequency	Rx Amp.	Correction Factor	Correct. Emi.	Limit	Margin	Antenna Polarization
MHz	(dBuV)	(dB)	(dBuV/m)	(dBuV/m)	(dB)	
13.11	19.12*	9.32	28.44	48.63	-20.19	H
13.11	18.89*	9.32	28.21	48.63	-20.42	V
14.01	18.83*	6.47	25.3	48.63	-23.33	H
14.01	17.72*	6.47	24.19	48.63	-24.44	V

Measurement Distance 3m

Frequency	Rx Amp.	Correction Factor	Correct. Emi.	Limit	Margin	Antenna Polarization
MHz	(dBuV)	(dB)	(dBuV/m)	(dBuV/m)	(dB)	
13.11	17.68*	9.32	27	69.54	-42.54	H
13.11	17.64*	9.32	26.96	69.54	-42.58	V
14.01	18.87*	6.47	25.34	69.54	-44.2	H
14.01	17.97*	6.47	24.44	69.54	-45.1	V

Note:

- ‘\*’ The value is detect on the Spectrum noise level.

**Band Edge measurement at 10m, Horizontal**

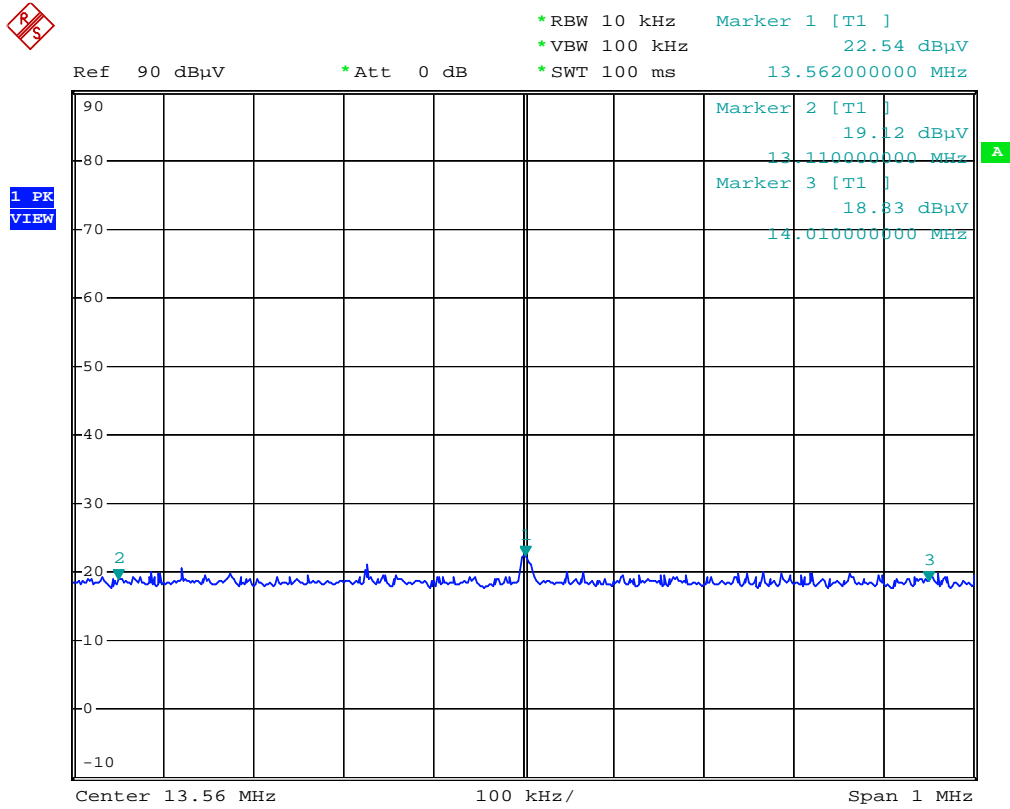

**Band Edge measurement at 10m, Vertical**

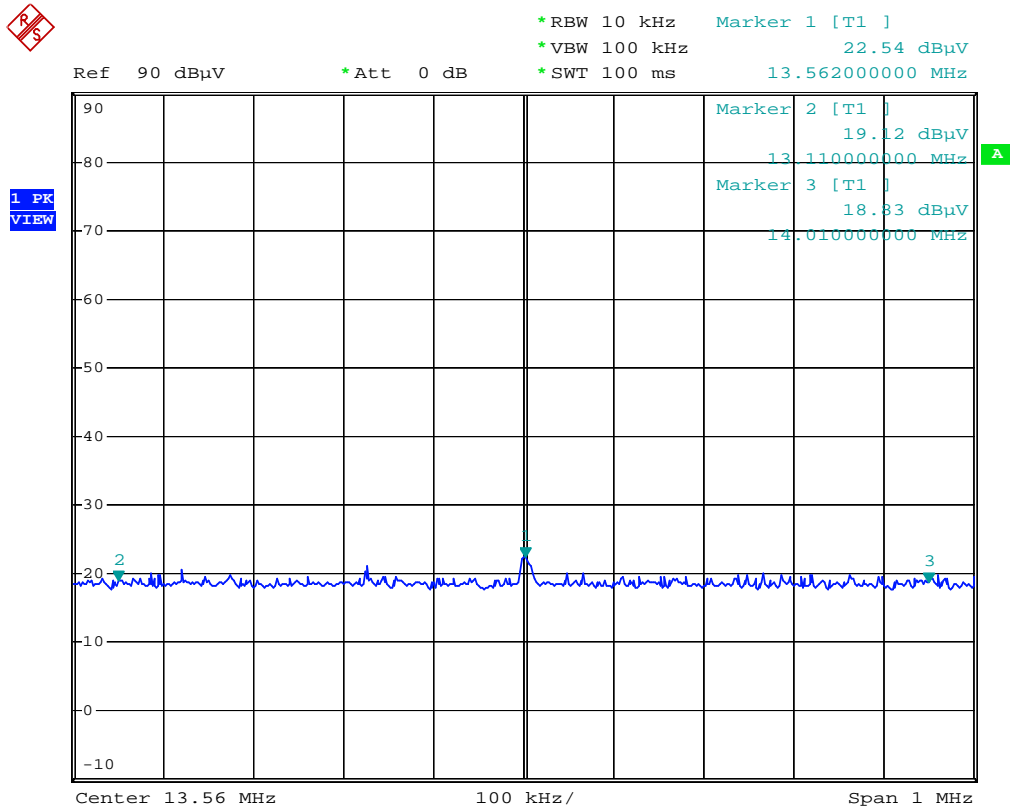

**Band Edge measurement at 3m, Horizontal**

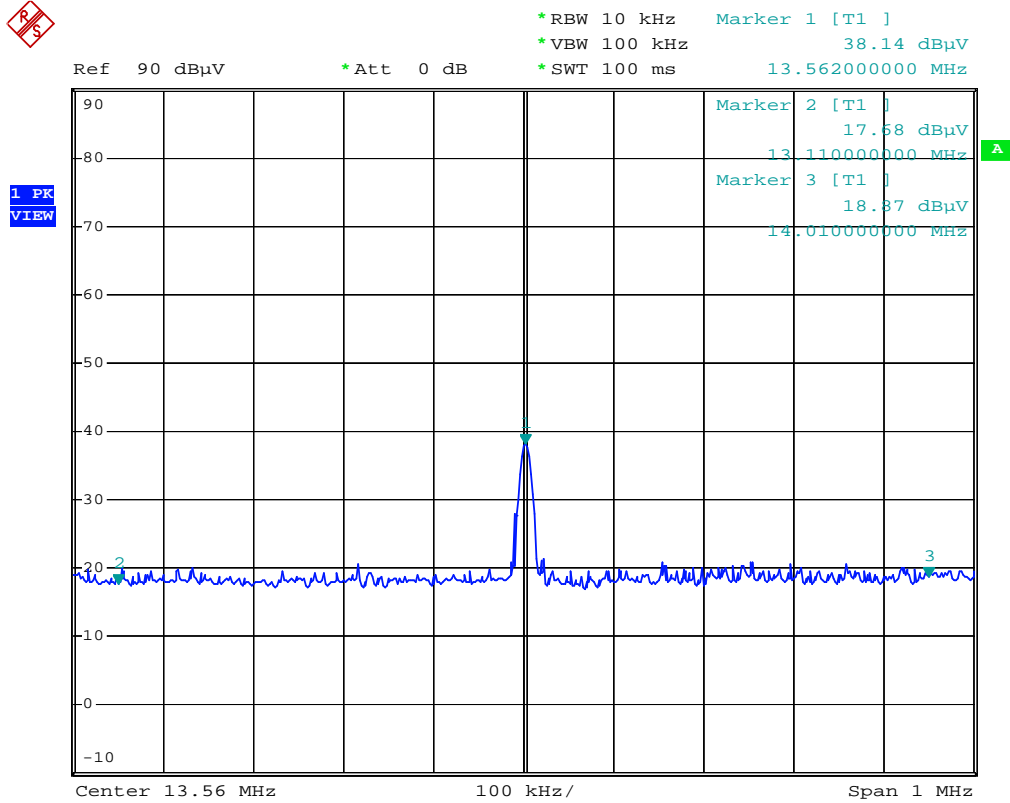

**Band Edge measurement at 3m, Vertical**

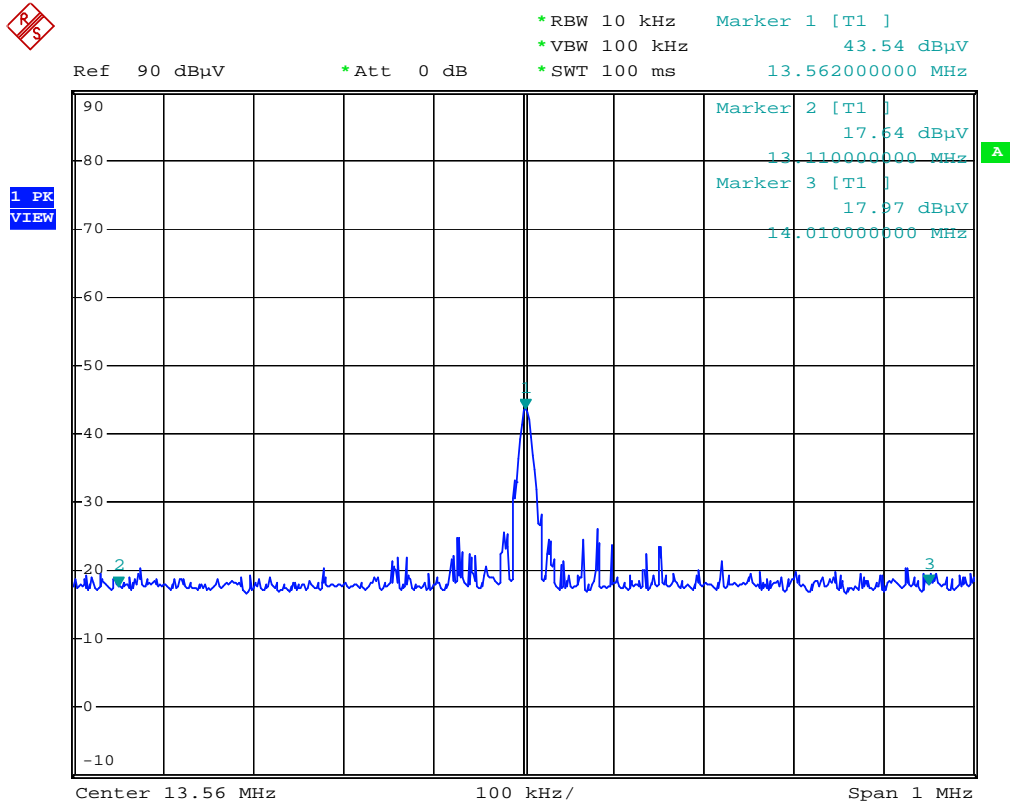

**4.2.7 Test Data (RADIATED OF SPURIOUS EMISSION)(9KHz – 1GHz):**

**9KHz - 30MHz Open Field Radiated Emissions**

Measurement Distance 10m

Frequency	Rx Amp.	Correction Factor	Correct. Emi.	Limit	Margin	Antenna Polarization
MHz	(dBuV)	(dB)	(dBuV/m)	(dBuV/m)	(dB)	
27.12	17.48*	10.09	27.57	48.63	-21.06	H
27.12	17.27*	10.09	27.36	48.63	-21.27	V

Measurement Distance 3m

Frequency	Rx Amp.	Correction Factor	Correct. Emi.	Limit	Margin	Antenna Polarization
MHz	(dBuV)	(dB)	(dBuV/m)	(dBuV/m)	(dB)	
27.12	17.48*	10.09	27.57	69.54	-41.97	H
27.12	17.06*	10.09	27.15	69.54	-42.39	V

Note:

- “\*” The value is detect on the Spectrum noise level.



### 30M – 1GHz Open Field Radiated Emissions (Horizontal)



Address: No.120, Lane 180, San Ho Tsuen, Hsin Ho Road  
Lung-Tan Hsiang, Tao Yuan Conty, Taiwan R.O.C.  
Tel: 03-4071718

Radiated Emission Measurement

Date: 2009/8/18  
Time: AM 10:29:42

Operator: Scott  
Temperature: 25 °C  
Humidity: 55 %

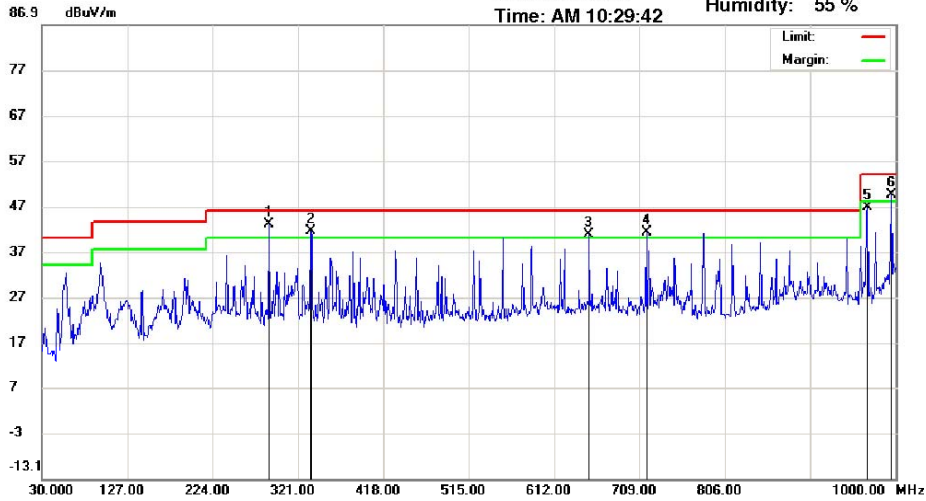

Site : Chamber 14

Condition : FCC Class B 3M Radiation

Polarization: *Horizontal*

Mk.	Frequency (MHz)	RX_R (dBuV/m)	Ant_F (dB)	Cab_L (dB)	PreAmp (dB)	Emission (dBuV/m)	Limit (dBuV/m)	Margin (dB)	Ant.Pos (cm)	Tab.Pos (deg.)	Detector
1	288.0200	63.39	12.96	3.81	37.01	43.15	46.00	-2.85	100	115	peak
2	335.5500	59.97	14.34	4.21	36.93	41.59	46.00	-4.41	112	322	peak
3	651.7700	52.00	19.1	6.17	36.5	40.77	46.00	-5.23	100	201	peak
4	716.7600	51.75	19.3	6.53	36.38	41.20	46.00	-4.80	361	2	peak
5	967.9900	53.79	20.98	7.83	35.93	46.67	54.00	-7.33	100	137	peak
6	995.1500	56.01	21.25	8.07	35.9	49.43	54.00	-4.57	339	228	peak

\*:Maximum data    x:Over limit    !:over margin

30MHz~ 1 GHz (Vertical)



Address: No.120, Lane 180, San Ho Tsuen, Hsin Ho Road  
Lung-Tan Hsiang, Tao Yuan Conty, Taiwan R.O.C.  
Tel: 03-4071718

Radiated Emission Measurement  
Date: 2009/8/18  
Time: AM 10:35:58

Operator: Scott  
Temperature: 25 °C  
Humidity: 55 %

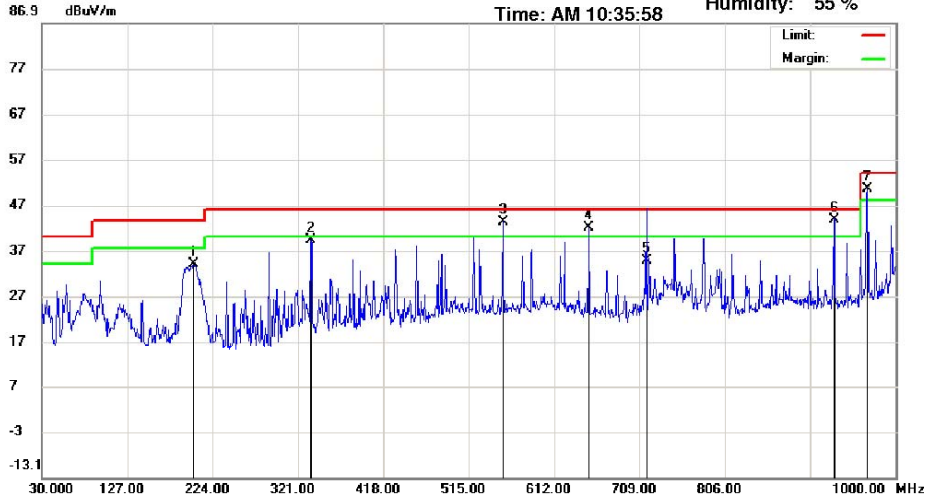

Site : Chamber 14

Condition : FCC Class B 3M Radiation

Polarization: Vertical

Mic.	Frequency (MHz)	RX_R (dBuV/m)	Ant_F (dB)	Cab_L (dB)	PreAmp (dB)	Emission (dBuV/m)	Limit (dBuV/m)	Margin (dB)	Ant.Pos (cm)	Tab.Pos (deg.)	Detector
1	202.6600	58.73	9.27	3.13	37.1	34.03	43.50	-9.47	321	102	peak
2	335.5500	57.67	14.34	4.21	36.93	39.29	46.00	-6.71	100	295	peak
3	553.8000	55.01	19.08	5.73	36.65	43.17	46.00	-2.83	100	104	peak
4	651.7700	53.20	19.1	6.17	36.5	41.97	46.00	-4.03	366	84	peak
5	716.6220	45.45	19.3	6.53	36.38	34.90	46.00	-11.10	100	360	QP
6	930.1600	51.64	20.64	7.59	35.97	43.90	46.00	-2.10	369	155	peak
7	967.9900	57.73	20.98	7.83	35.93	50.61	54.00	-3.39	281	155	peak

\*:Maximum data x:Over limit !:over margin

### 4.3 Frequency Stability Measurement

#### 7.1.1. Limits of Frequency Stability Measurement

The frequency tolerance of the carrier signal shall be maintained within  $\pm 0.01\%$  of the operating frequency over a temperature variation of  $-20^{\circ}\text{C}$  to  $+50^{\circ}\text{C}$  at normal supply voltage, and for a variation in the primary supply voltage from 85% to 115% of the rated supply voltage at a temperature of  $20^{\circ}\text{C}$ . For battery operated equipment, the equipment tests shall be performed using a new battery. The emission limit is based on measurement instrumentation employing an average detector.

#### 7.1.2. Test Procedure

1. The EUT was placed in the Temperature/Humidity Chamber and powered by a Voltage/Frequency Power converter.
2. Connect the RF output of EUT to Spectrum.
3. Set the temperature of chamber to  $20^{\circ}\text{C}$ .
4. While maintaining a constant temperature inside the Temperature/Humidity Chamber, turn the EUT on and record the operating frequency at startup and two, five, and ten minutes after the EUT is energized.
5. Turn the EUT off and set the chamber to the highest temperature specified.
6. Reduce  $10^{\circ}\text{C}$  and repeat step 4, 5, 6 until the temperature of chamber set to the lowest temperature.
7. Set the temperature of chamber to  $20^{\circ}\text{C}$  and the Voltage/Frequency Power Converter to 85% and 115% of supply voltage, then repeat step 4.

#### 7.1.3. Test Setup

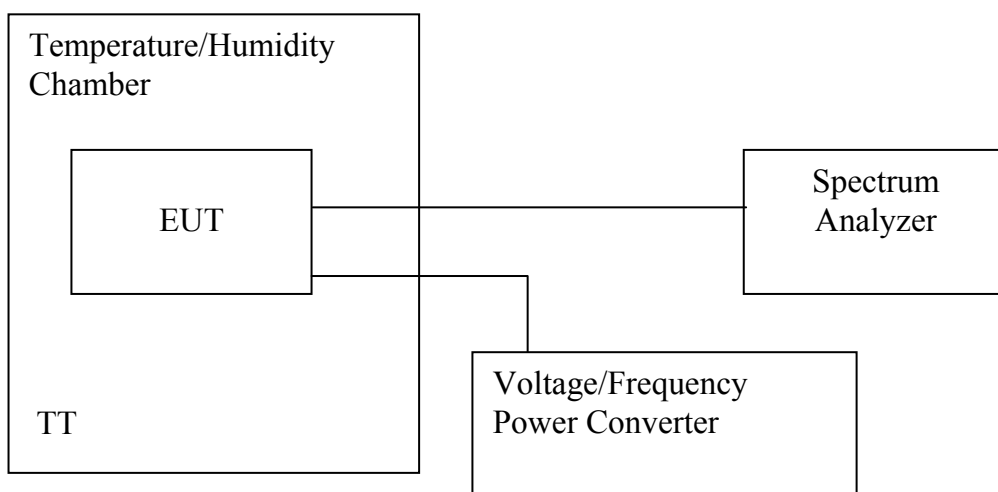

### 4.3.1 Test Data

#### Frequency Stability

Temp.	Power Supply	Observe Time	Read Frequency	Tolerance	Pass or Fail
(°C)	(V AC)		(MHz)	(%)	Limit: +/- 0.01%
20	120	Start	13.56228	N/A	0
		2mins	13.56229	N/A	0
		5mins	13.56229	N/A	0
		10mins	13.56229	N/A	0
50	120	Start	13.56227	-0.000074	PASS
		2mins	13.56227	-0.000147	PASS
		5mins	13.56227	-0.000147	PASS
		10mins	13.56227	-0.000147	PASS
40	120	Start	13.56228	0.000000	PASS
		2mins	13.56228	-0.000074	PASS
		5mins	13.56227	-0.000147	PASS
		10mins	13.56227	-0.000147	PASS
30	120	Start	13.56234	0.000442	PASS
		2mins	13.56233	0.000295	PASS
		5mins	13.56233	0.000295	PASS
		10mins	13.56231	0.000147	PASS
10	120	Start	13.56231	0.000221	PASS
		2mins	13.56235	0.000442	PASS
		5mins	13.56234	0.000369	PASS
		10mins	13.56234	0.000369	PASS
0	120	Start	13.56236	0.000590	PASS
		2mins	13.56236	0.000516	PASS
		5mins	13.56236	0.000516	PASS
		10mins	13.56236	0.000516	PASS
-10	120	Start	13.56236	0.000590	PASS
		2mins	13.56236	0.000516	PASS
		5mins	13.56236	0.000516	PASS
		10mins	13.56236	0.000516	PASS

Temp.	Power Supply	Observe Time	Read Frequency	Tolerance	Pass or Fail
(°C)	(V AC)		(MHz)	(%)	Limit: +/- 0.01%
-20	120	Start	13.56235	0.000516	PASS
		2mins	13.56236	0.000516	PASS
		5mins	13.56237	0.000590	PASS
		10mins	13.56236	0.000516	PASS
20	138	Start	13.56229	0.000074	PASS
		2mins	13.56229	0.000000	PASS
		5mins	13.56229	0.000000	PASS
		10mins	13.56229	0.000000	PASS
20	102	Start	13.56231	0.000221	PASS
		2mins	13.56231	0.000147	PASS
		5mins	13.56231	0.000147	PASS
		10mins	13.56231	0.000147	PASS

## 4.4 Occupied bandwidth measurements [ANSI C63.4 section 13.1.7]

### 4.4.1 Test Procedure

The Transmitter output of EUT was connected to the spectrum analyzer. The 26 dB bandwidth of the fundamental frequency was measured. The setting of spectrum analyzer is as follows

Equipment mode	Spectrum analyzer
Detector function	Peak mode
RBW	1KHz
VBW	10KHz

### 4.4.2 Test Setup

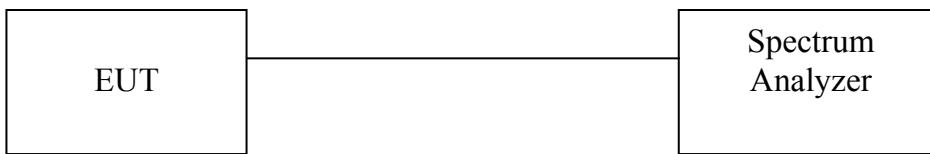

### 4.4.3 Test Data:

Frequency (MHz)	26dB Bandwidth (KHz)
13.56	9.8

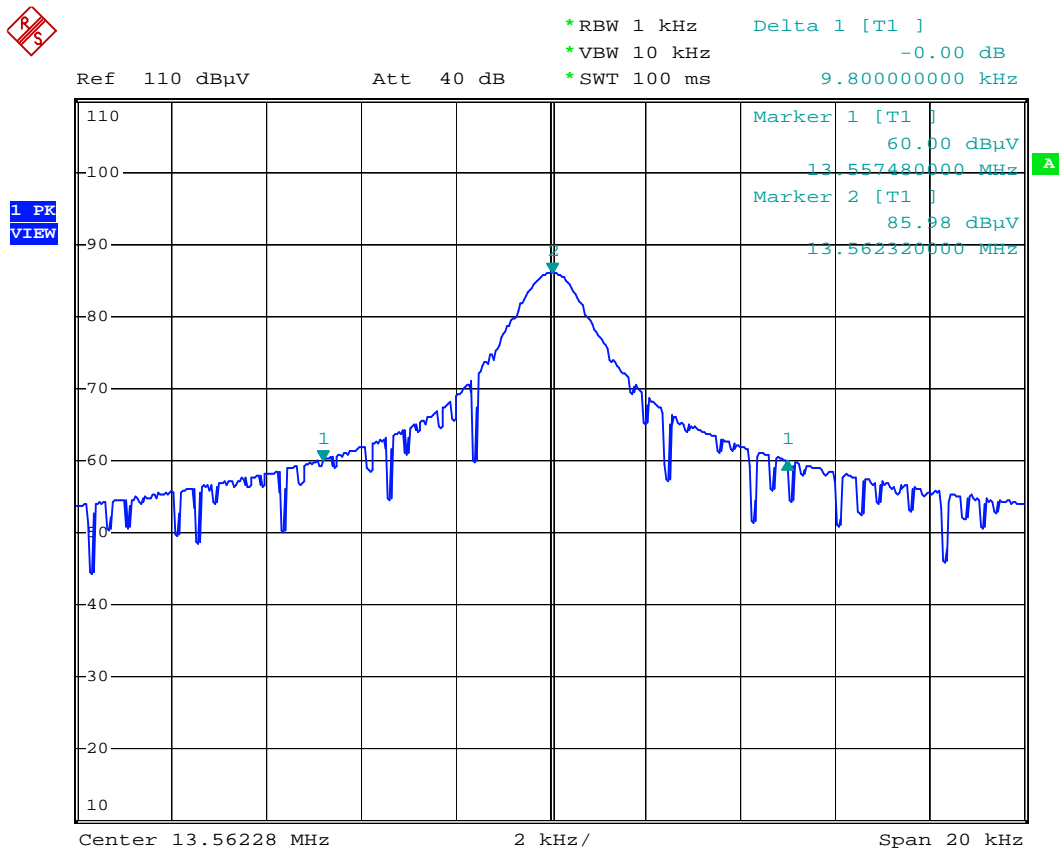

## 5. Appendix

### 5.1 Appendix A: Measurement Procedure for Power line Conducted Emissions

The measurements are performed in a 3.5m x 3.4m x 2.5m shielded room, which referred as Conduction 01 test site, or a 3m x 3m x 2.3m test site, which referred as Conduction 02 test site. The EUT was placed on non-conduction 1.0m x 1.5m table, which is 0.8 meters above an earth-grounded.

Power to the EUT was provided through the LISN which has the Impedance (50ohm/50uH) vs. Frequency Characteristic in accordance with the required standard. Power to the LISNs were filtered to eliminate ambient signal interference and these filters were bonded to the ground plane. Peripheral equipment required to provide a functional system (support equipment) for EUT testing was powered from the second LISN through a ganged, metal power outlet box which is bonded to the ground plane at the LISN.

If the EUT is supplied with a flexible power cord, the power cord length in excess of the distance separating the EUT from the LISN shall be folded back and forth at the center of the lead so as to form a bundle not exceeding 40cm in length. If the EUT is provided with a permanently coiled power cord, bundling of the cord is not required. If the EUT is supplied without a power cord, the EUT shall be connected to the LISN by a power cord of the type specified by the manufacturer which shall not be longer than 1 meter. The excess power cord shall be bundled as described above. If a non-flexible power cord is provided with the EUT, it shall be cut to the length necessary to attach the EUT to the LISN and shall not be bundled.

The interconnecting cables were arranged and moved to get the maximum emission. Both the line of power cord, hot and neutral, were measured.

The highest emissions were analyzed in details by operating the spectrum analyzer in fixed tuned mode to determine the nature of the emissions and to provide information which could be useful in reducing their amplitude.

## 5.2 Appendix B: Test Procedure for Radiated Emissions

### Preliminary Measurements in the Anechoic Chamber

The radiated emissions are initially measured in the anechoic chamber at a measurement distance of 3 meters. Desktop EUT are placed on a wooden stand 0.8 meter in height. The measurement antenna is 3 meters from the EUT. The test setup in anechoic chamber is the same as open site. The turntable rotated 360°. The antenna height is varied from 1-2.5m. The primary objective of the radiated measurements in the anechoic chamber is to identify the frequency spectrum in the absence of the electromagnetic environment existing on the open test site. The frequencies can then be pre-selected on the open test site to obtain the corresponding amplitude. The initial scan is made with the spectrum analyzer in automatic sweep mode. The spectrum peaks are then measured manually to determine the exact frequencies.

### Measurements on the Open Site or 10m EMC Chamber

The radiated emissions test will then be repeated on the open site or 10m EMC chamber to measure the amplitudes accurately and without the multiple reflections existing in the shielded room. The EUT and support equipment are set up on the turntable of one of the 3 or 10 meter open field sites. Desktop EUT are set up on a wooden stand 0.8 meter above the ground.

For the initial measurements, the receiving antenna is varied from 1-4 meter height and is changed in the vertical plane from vertical to horizontal polarization at each frequency. Both reading are recorded with the quasi-peak detector with 120KHz bandwidth. For frequency between 30 MHz and 1000MHz, the reading is recorded with peak detector or quasi-peak detector. For frequency above 1 GHz, the reading is recorded with peak detector or average detector with 1 MHz bandwidth.

At the highest amplitudes observed, the EUT is rotated in the horizontal plane while changing the antenna polarization in the vertical plane to maximize the reading. The interconnecting cables were arranged and moved to get the maximum emission. Once the maximum reading is obtained, the antenna elevation and polarization will be varied between specified limits to maximize the readings.



## 5.3 Appendix C: Test Equipment

### 5.3.1 Test Equipment List

Location	Equipment Name	Brand	Model	S/N	Last Cal. Date	Next Cal. Date
Radiation (Chamber12)	Coaxial Cable Chmb 12-10M-01	PEWC	CFD400-NL	Chmb 12-10M-01	06/15/2009	06/15/2010
Radiation (Chamber12)	EMI Receiver 10	ROHDE & SCHWARZ	ESCI	100567	06/09/2009	06/09/2010
Radiation	Loop Antenna 03	Com-Power	AL-130	17101	10/23/2008	10/23/2010
Radiation (Chamber14)	BILOG Antenna 14	Schaffner	CBL6112D	22612	03/17/2009	03/17/2010
Radiation (Chamber14)	Coaxial Cable Chmb 14-3M	NOKIA KABEL	M17/74-RG21 3	Chmb 14-3M	07/08/2009	07/08/2010
Radiation (Chamber14)	EMI Receiver 06	Schwarzbeck Mess-Elektronik	FCVU 1534	1534-149	07/02/2009	07/02/2010
Radiation (Chamber14)	Spectrum Analyzer 21	Agilent	N9010A	MY49060537	07/03/2009	07/03/2010
Rad. Above 1GHz (Chamber14)	SUCOFLEX 1GHz~18GHz cable	HUBER+SUHN ER AG.	Sucoflex 106 & 104	60404/6 & 286303/4	07/06/2009	07/06/2010
Rad. Above 1GHz (Chamber14)	SUCOFLEX 1GHz~40GHz cable	HUBER+SUHN ER AG.	Sucoflex 102	27963/2	09/10/2008	09/10/2009

Location	Equipment Name	Brand	Model	S/N	Last Cal. Date	Next Cal. Date
Conduction 02	Conduction 02 -1 Cable	WOKEN	CFD 300-NL	Conduction 02 -1	06/15/2009	06/15/2010
Conduction 02	Spectrum Analyzer 20	Agilent Technologies	E4443A	MY48250315	04/14/2009	04/14/2010
Conduction 02	RF Pre-selector 01	Agilent Technologies	N9039A	MY46520296	04/24/2009	04/24/2010
Conduction 02	ISN T2 01	FCC	FCC-TLISN-T 2-02	20253	07/20/2009	07/20/2010
Conduction 02	ISN T4 03	FCC	FCC-TLISN-T 4-02	20254	07/20/2009	07/20/2010
Conduction 02	ISN T8 01	FCC	FCC-TLINS-T 8-02	20255	07/20/2009	07/20/2010
Conduction 02	LISN 01	R&S	ESH2-Z5	890485/013	12/25/2008	12/25/2009
Conduction 02	LISN 04	EMCO	3810/2	9604-1429	05/13/2009	05/13/2010

Note: Calibration is traceable to NIST or national or international standards.

### 5.3.2 Software for Controlling Spectrum/Receiver and Calculating Test Data

Radiation/Conduction	Filename	Version	Issued Date
Lung_Tan Conduction	EZ EMC	1.1.4.2	2/10/2007
Lung_Tan Radiation	EZ EMC	1.1.4.2	1/24/2007

## 5.4 Appendix D: Layout of EUT and Support Equipment

### 5.4.1 General Conducted Test Configuration

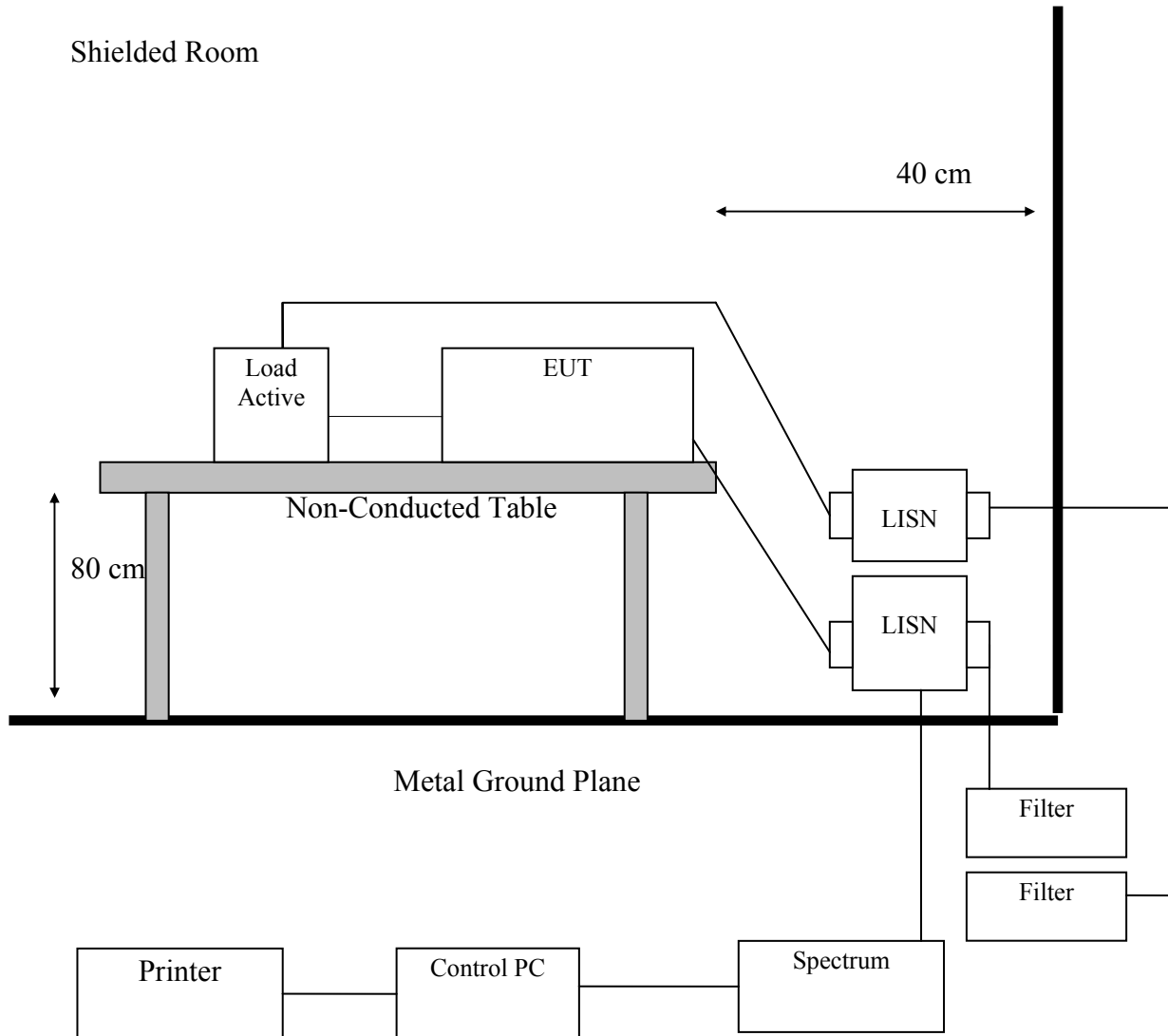

**5.4.2 General Radiation Test Configuration**

**9KHz~30MHz**

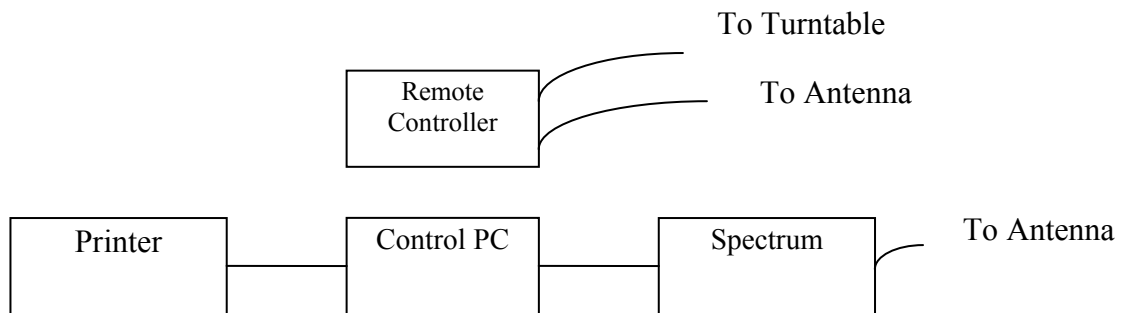
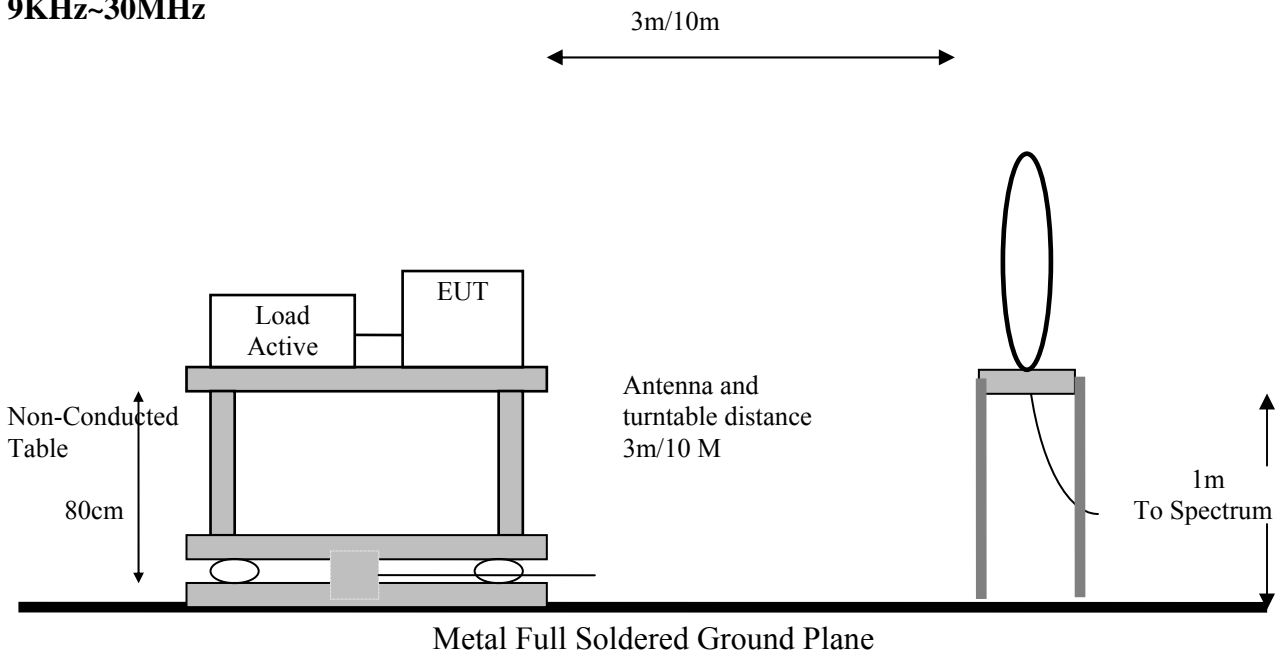

30MHz~1GHz

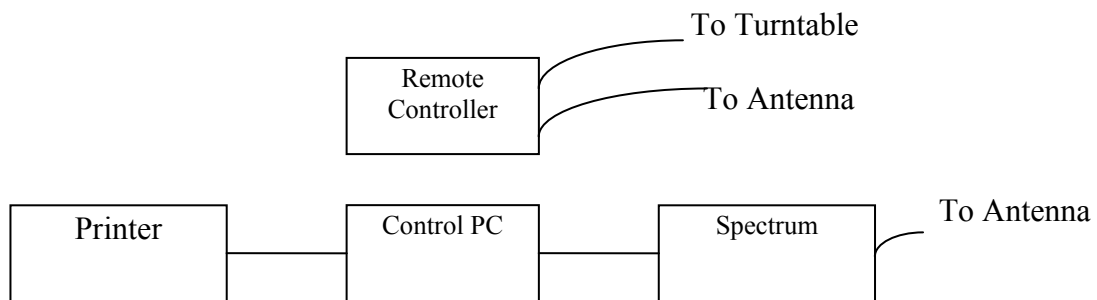
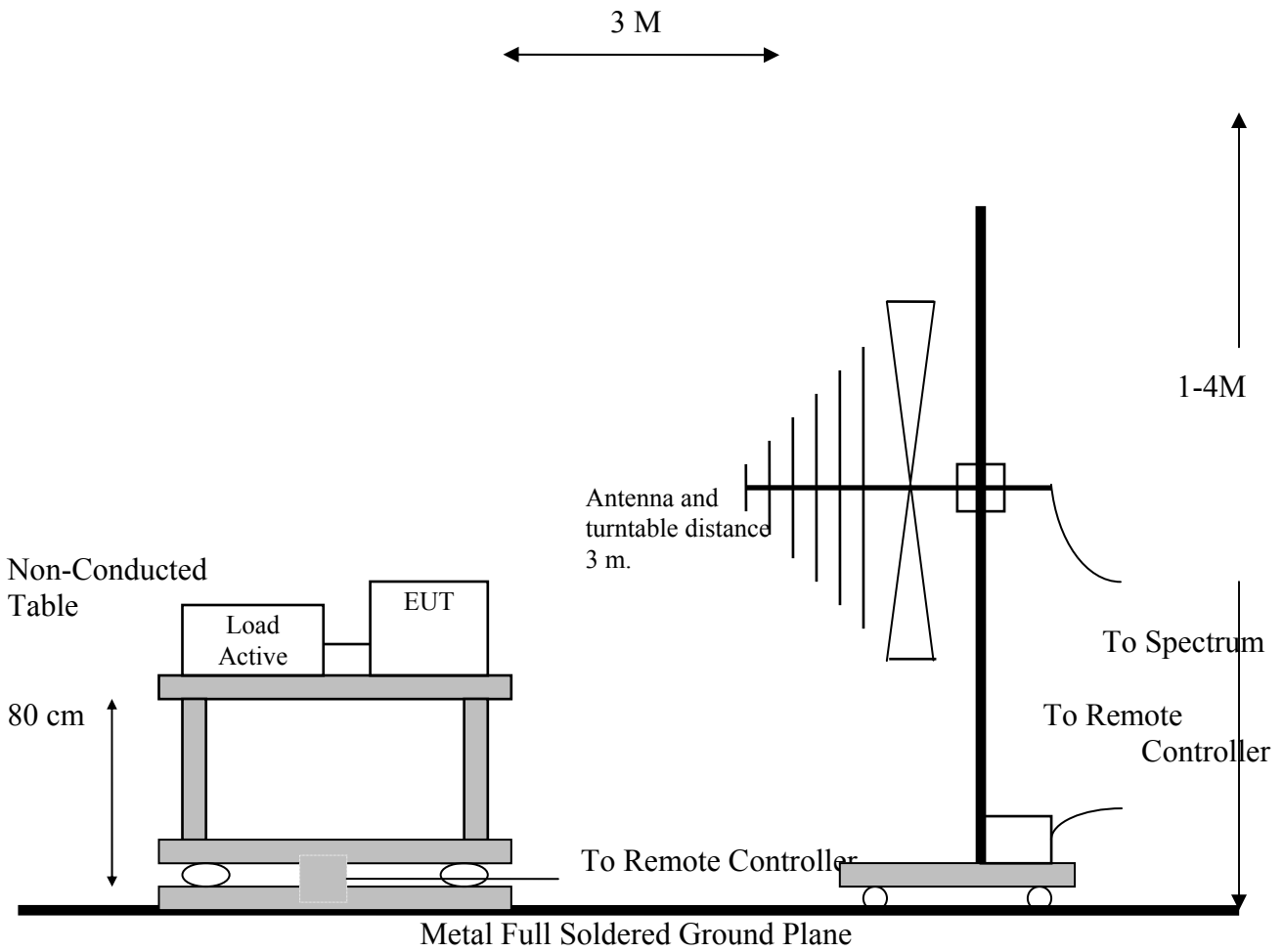

## 5.5 Appendix E: Accuracy of Measurement

The measurement uncertainty refers to CISPR 16-4-2:2003. The coverage factor  $k = 2$  yields approximately a 95 % level of confidence.

<Conduction 02>:  $\pm 3.233$  dB

<Chamber 12 (10M)>

9kHz~30MHz:  $\pm 2.597$  dB

<Chamber 14 (3M)>

30MHz~1GHz:  $\pm 4.166$  dB

1GHz~18GHz:  $\pm 3.722$  dB

18GHz~26GHz:  $\pm 3.688$  dB

26GHz~40GHz:  $\pm 3.723$  dB

## 5.6 Appendix F: Photographs of EUT Configuration Test Set Up

The Front View of Highest Conducted Set-up For EUT

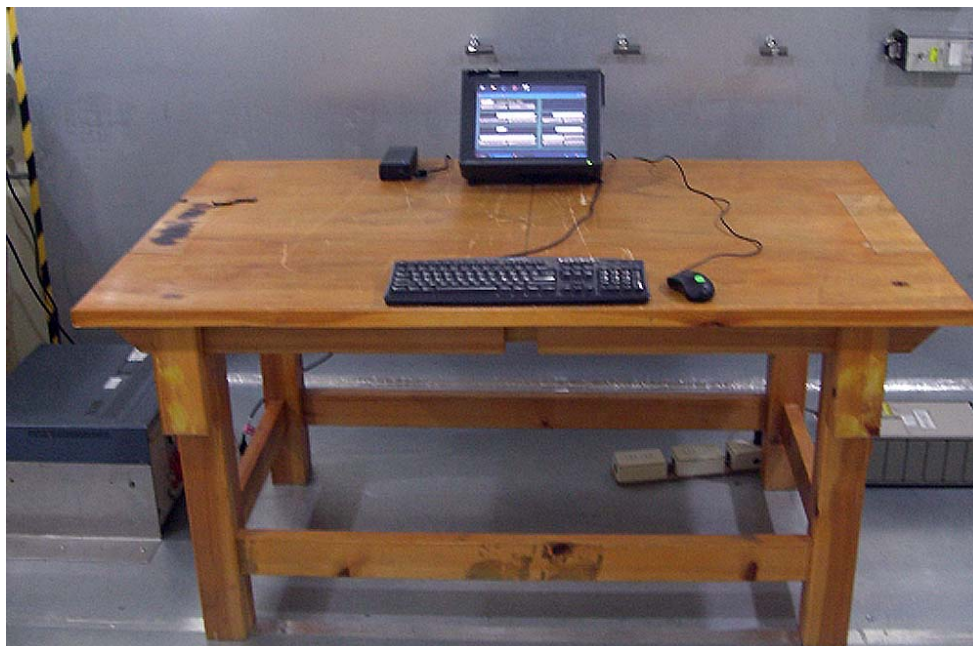

The Front View of Highest Radiated Set-up For EUT (9KHz~30MHz)



The Back View of Highest Radiated Set-up For EUT (9KHz~30MHz)

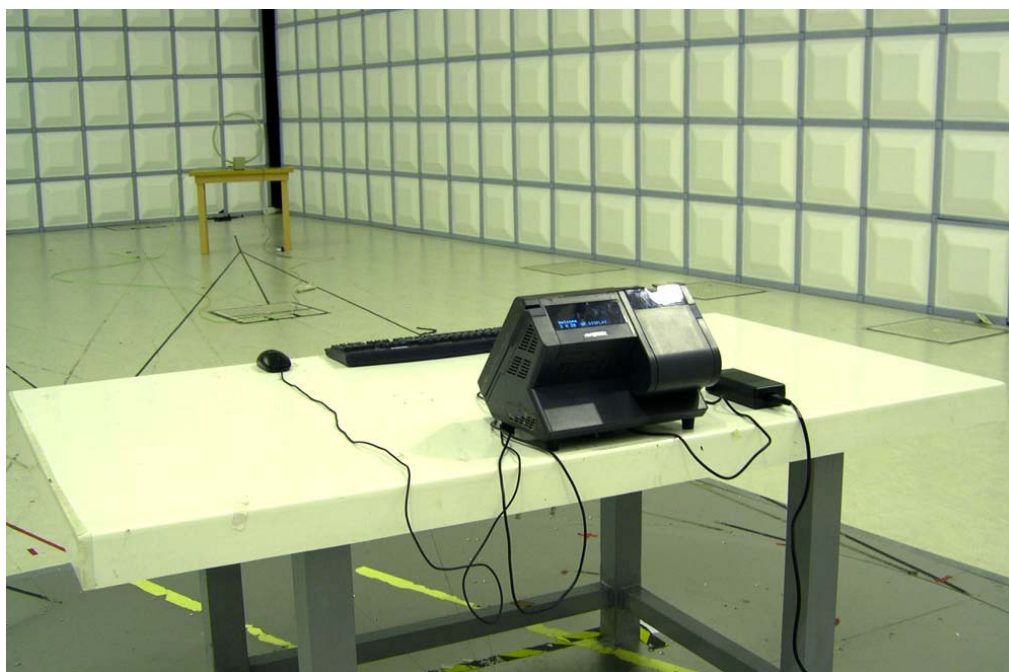

The Front View of Highest Radiated Set-up For EUT (30MHz~1GHz)



The Back View of Highest Radiated Set-up For EUT (30MHz~1GHz)





## 5.7 Appendix G: Photographs of EUT

### EUT-1. POS Terminal



EUT-2. **POS Terminal**



EUT-3. POS Terminal built in RFID module

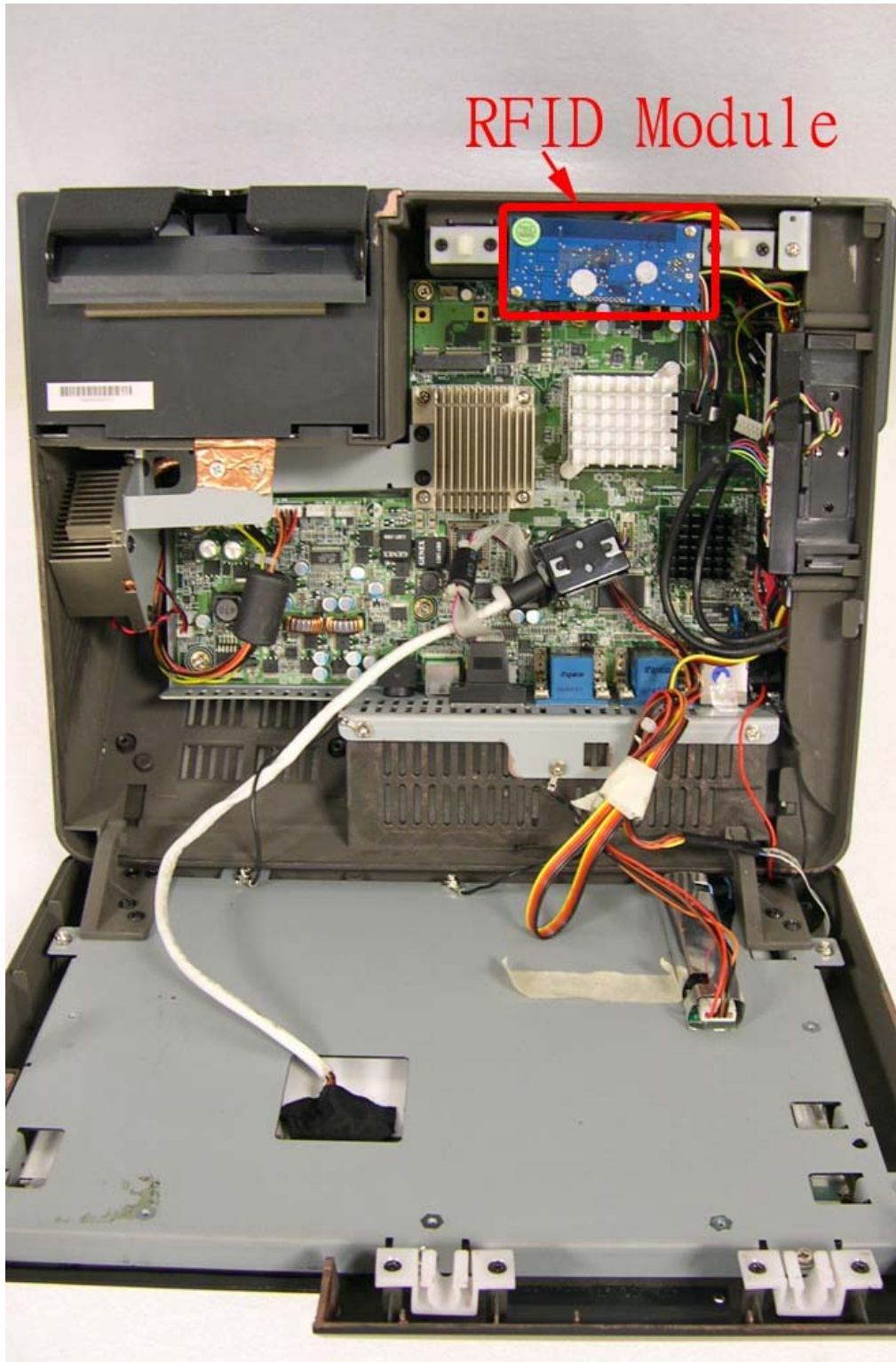

EUT-4. **RFID module**

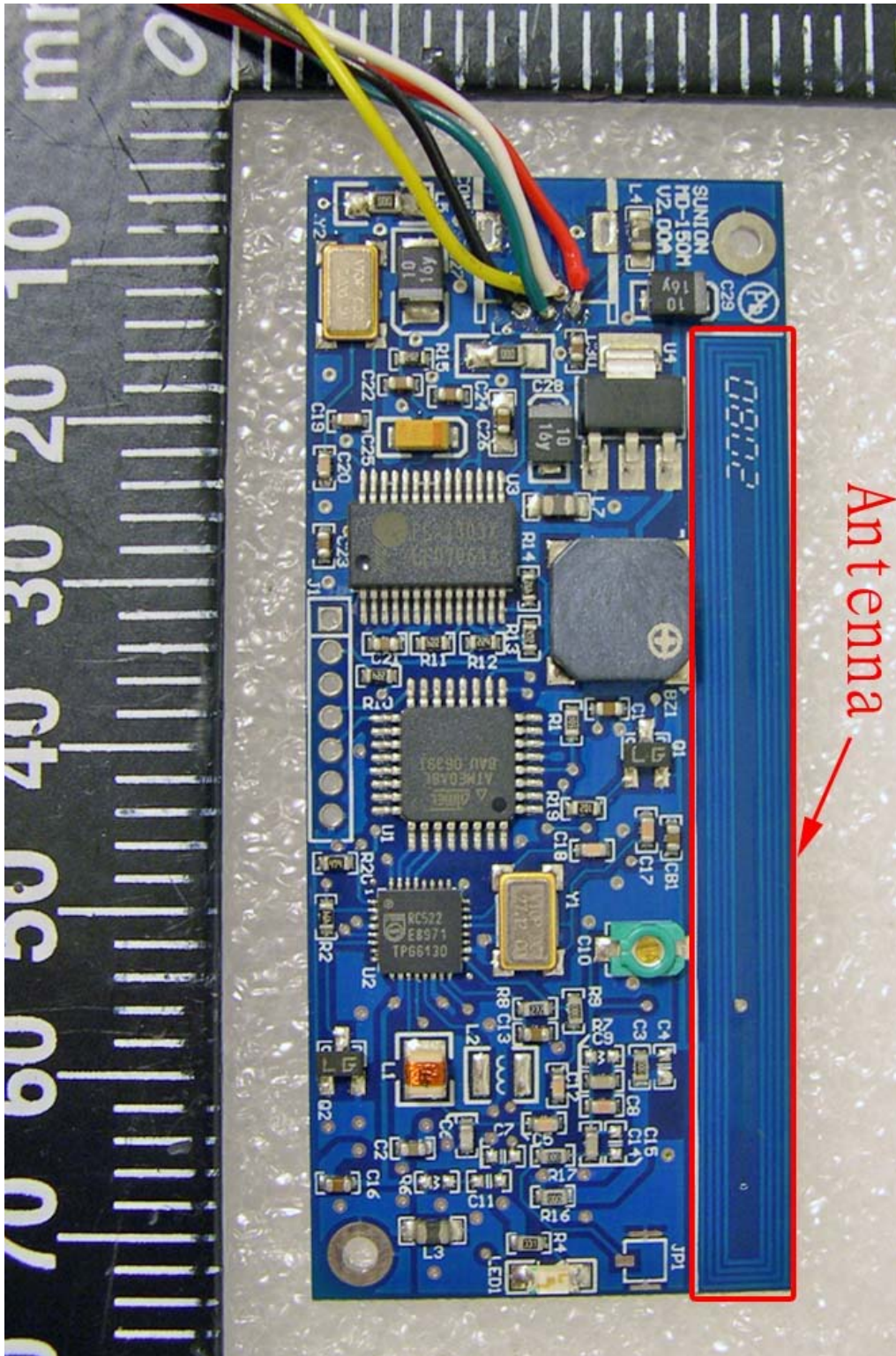

EUT-5. **RFID module**

