



FCC 47 CFR PART 15 SUBPART E

TEST REPORT

For

AC1200 Wireless LAN Dual Band Concurrent Gigabit Router

Model: BR-6477AC

Trade Name: EDIMAX

Issued to

EDIMAX TECHNOLOGY CO., LTD.

No.3,Wu-Chuan 3rd Road,Wu-Ku Industrial Park, New Taipei City, Taiwan

Issued by

Compliance Certification Services Inc.

**No.11, Wugong 6th Rd., Wugu Dist.,
New Taipei City 24891, Taiwan. (R.O.C.)**

<http://www.ccsrf.com>

service@ccsrf.com

Issued Date: October 30, 2014



Note: This report shall not be reproduced except in full, without the written approval of Compliance Certification Services Inc. This document may be altered or revised by Compliance Certification Services Inc. personnel only, and shall be noted in the revision section of the document.



Revision History

Rev.	Issue Date	Revisions	Effect Page	Revised By
00	October 30, 2014	Initial Issue	ALL	Doris Chu



TABLE OF CONTENTS

1. TEST RESULT CERTIFICATION.....	4
2. EUT DESCRIPTION	5
3. TEST METHODOLOGY	6
3.1 EUT CONFIGURATION	6
3.2 EUT EXERCISE	6
3.3 GENERAL TEST PROCEDURES.....	6
3.4 FCC PART 15.205 RESTRICTED BANDS OF OPERATIONS.....	7
3.5 DESCRIPTION OF TEST MODES.....	8
4. INSTRUMENT CALIBRATION.....	9
4.1 MEASURING INSTRUMENT CALIBRATION	9
4.2 MEASUREMENT EQUIPMENT USED.....	9
4.3 MEASUREMENT UNCERTAINTY.....	10
5. FACILITIES AND ACCREDITATIONS	11
5.1 FACILITIES	11
5.2 EQUIPMENT.....	11
5.3 TABLE OF ACCREDITATIONS AND LISTINGS	12
6. SETUP OF EQUIPMENT UNDER TEST	13
6.1 SETUP CONFIGURATION OF EUT	13
6.2 SUPPORT EQUIPMENT	13
7. FCC PART 15 REQUIREMENTS.....	14
7.1 26 DB EMISSION BANDWIDTH	14
7.2 MAXIMUM CONDUCTED OUTPUT POWER	35
7.3 BAND EDGES MEASUREMENT	40
7.4 PEAK POWER SPECTRAL DENSITY	49
7.5 RADIATED UNDESIRABLE EMISSION	70
7.6 POWERLINE CONDUCTED EMISSIONS	93
7.7 FREQUENCY STABILITY	96
APPENDIX I PHOTOGRAPHS OF TEST SETUP	112
APPENDIX 1 - PHOTOGRAPHS OF EUT	



1. TEST RESULT CERTIFICATION

Applicant: EDIMAX TECHNOLOGY CO., LTD.
 No.3,Wu-Chuan 3rd Road,Wu-Ku Industrial Park, New Taipei City,
 Taiwan

Equipment Under Test: AC1200 Wireless LAN Dual Band Concurrent Gigabit Router

Trade Name: EDIMAX

Model: BR-6477AC

Date of Test: October 10 ~ 22, 2014

APPLICABLE STANDARDS	
STANDARD	TEST RESULT
FCC 47 CFR Part 15 Subpart E	No non-compliance noted

We hereby certify that:

Compliance Certification Services Inc. tested the above equipment. The test data, data evaluation, test procedures, and equipment configurations shown in this report were made in accordance with the procedures given in ANSI C63.4: 2003 and the energy emitted by the sample EUT tested as described in this report is in compliance with conducted and radiated emission limits of FCC Rules Part 15.407.

The test results of this report relate only to the tested sample identified in this report.

Approved by:

Reviewed by:

Miller Lee
 Section Manager
 Compliance Certification Services Inc.

Angel Cheng
 Section Manager
 Compliance Certification Services Inc.



2. EUT DESCRIPTION

Product	AC1200 Wireless LAN Dual Band Concurrent Gigabit Router				
Trade Name	EDIMAX				
Model Number	BR-6477AC				
Model Discrepancy	N/A				
Received Date	September 30, 2014				
Power Adapter	DVE / DSA-12PFA-09 FUS 120100 I/P: 100-240Vac, 50/60Hz, 0.5A O/P: +12Vdc, 1A				
Frequency Range	IEEE 802.11a, IEEE 802.11n HT20 : 5180MHz ~ 5240MHz; 5745 ~ 5825MHz IEEE 802.11n HT40 : 5190MHz ~ 5230MHz; 5755 ~ 5795MHz IEEE 802.11ac VHT80 mode: 5210MHz; 5775MHz				
Channel Number	IEEE 802.11a, IEEE 802.11n HT20 : 5180MHz ~ 5825MHz : 9 Channels IEEE 802.11n HT40 : 5190MHz ~ 5795MHz : 4 Channels IEEE 802.11ac VHT80 mode: 5210MHz ~ 5775MHz : 2 Channels				
Transmit Power		Mode	Frequency Range (MHz)	Transmit Power (dBm)	Transmit Power (W)
	UNII Band I	IEEE 802.11a	5180 – 5240	16.95	0.0495
		IEEE 802.11n HT 20 mode	5180 – 5240	17.79	0.0601
		IEEE 802.11n HT 40 mode	5190 ~ 5230	16.87	0.0486
		IEEE 802.11ac VHT80 mode	5210	18.01	0.0632
	UNII Band VI	IEEE 802.11a	5745 ~ 5825	18.68	0.0738
		IEEE 802.11n HT 20 mode	5745 ~ 5825	18.67	0.0736
		IEEE 802.11n HT 40 mode	5755 ~ 5815	18.66	0.0735
		IEEE 802.11ac VHT80 mode	5775	18.30	0.0676
Modulation Technique	OFDM (QPSK, BPSK, 16-QAM, 64-QAM, 256QAM)				
Transmit Data Rate	IEEE 802.11a mode: 54, 48, 36, 24, 18, 12, 9, 6 Mbps IEEE 802.11n HT 20 mode: OFDM (6.5, 7.2, 13, 14.4, 14.44, 19.5, 21.7, 26, 28.89, 28.9, 39, 43.3, 43.33 52, 57.78, 57.8, 58.5, 65.0, 72.2, 78, 86.67, 104, 115.56, 117, 130, 144.44 Mbps) IEEE 802.11n HT 40 mode: OFDM (13.5, 15, 27, 30, 40.5, 45, 54, 60, 81, 90, 108, 120, 121.5, 135, 150, 162, 180, 216, 240, 243, 270, 300 Mbps) IEEE 802.11ac VHT80 mode: OFDM (29.3, 58.5, 87.8, 117, 175.5, 234, 263.3, 292.5, 351, 390, 468, 526.5, 585, 702, 780 Mbps)				
Antenna Specification	PIFA Antenna / Gain: 3 dBi				

Remark:

1. The sample selected for test was engineering sample that approximated to production product and was provided by manufacturer.
2. This submittal(s) (test report) is intended for FCC ID: NDD9564771412 filing to comply with Section 15.407 of the FCC Part 15, Subpart E Rules.



3. TEST METHODOLOGY

Both conducted and radiated testing was performed according to the procedures in ANSI C63.4. Radiated testing was performed at an antenna to EUT distance 3 meters.

3.1 EUT CONFIGURATION

The EUT configuration for testing is installed for RF field strength measurement to meet the Commissions requirement, and is operated in a manner intended to generate the maximum emission in a continuous normal application.

3.2 EUT EXERCISE

The EUT is operated in the engineering mode to fix the Tx frequency for the purposes of measurement.

According to its specifications, the EUT must comply with the requirements of Section 15.407 under the FCC Rules Part 15 Subpart E.

3.3 GENERAL TEST PROCEDURES

Conducted Emissions

The EUT is placed on the turntable, which is positioned at 0.8 m above the ground plane. According to the requirements in Section 13.1.4.1 of ANSI C63.4, the conducted emission from the EUT is measured in the frequency range between 0.15 MHz and 30MHz, using the CISPR Quasi-Peak detector mode.

Radiated Emissions

The EUT is placed on the turntable, which is 0.8 m above the ground plane. The turntable is then rotated for 360 degrees to determine the proper orientation for the maximum emission level. The EUT is set 3m away from the receiving antenna, which is varied from 1m to 4m to find out the highest emission level. And, each emission is to be maximized by changing the horizontal and vertical polarization of the receiving antenna. In order to find out the maximum emissions, exploratory radiated emission measurements were made according to the requirements in Section 13.1.4.1 of ANSI C63.4.



3.4 FCC PART 15.205 RESTRICTED BANDS OF OPERATIONS

(a) Except as shown in paragraph (d) of this section, only spurious emissions are permitted in any of the frequency bands listed below:

MHz	MHz	MHz	GHz
0.090 - 0.110	16.42 - 16.423	399.9 - 410	4.5 - 5.15
¹ 0.495 - 0.505	16.69475 - 16.69525	608 - 614	5.35 - 5.46
2.1735 - 2.1905	16.80425 - 16.80475	960 - 1240	7.25 - 7.75
4.125 - 4.128	25.5 - 25.67	1300 - 1427	8.025 - 8.5
4.17725 - 4.17775	37.5 - 38.25	1435 - 1626.5	9.0 - 9.2
4.20725 - 4.20775	73 - 74.6	1645.5 - 1646.5	9.3 - 9.5
6.215 - 6.218	74.8 - 75.2	1660 - 1710	10.6 - 12.7
6.26775 - 6.26825	108 - 121.94	1718.8 - 1722.2	13.25 - 13.4
6.31175 - 6.31225	123 - 138	2200 - 2300	14.47 - 14.5
8.291 - 8.294	149.9 - 150.05	2310 - 2390	15.35 - 16.2
8.362 - 8.366	156.52475 -	2483.5 - 2500	17.7 - 21.4
8.37625 - 8.38675	156.52525	2655 - 2900	22.01 - 23.12
8.41425 - 8.41475	156.7 - 156.9	3260 - 3267	23.6 - 24.0
12.29 - 12.293	162.0125 - 167.17	3332 - 3339	31.2 - 31.8
12.51975 - 12.52025	167.72 - 173.2	3345.8 - 3358	36.43 - 36.5
12.57675 - 12.57725	240 - 285	3600 - 4400	(²)
13.36 - 13.41	322 - 335.4		

¹ Until February 1, 1999, this restricted band shall be 0.490-0.510 MHz.

² Above 38.6

(b) Except as provided in paragraphs (d) and (e), the field strength of emissions appearing within these frequency bands shall not exceed the limits shown in Section 15.209. At frequencies equal to or less than 1000 MHz, compliance with the limits in Section 15.209 shall be demonstrated using measurement instrumentation employing a CISPR quasi-peak detector. Above 1000 MHz, compliance with the emission limits in Section 15.209 shall be demonstrated based on the average value of the measured emissions. The provisions in Section 15.35 apply to these measurements.



3.5 DESCRIPTION OF TEST MODES

The EUT (model: BR-6477AC) had been tested under operating condition.

The EUT is a 2x2 configuration spatial MIMO (2Tx & 2Rx) without beam forming function that operate in double TX chains and double RX chains. The 2x2 configuration is implemented with two outside TX & RX chains (Chain 0 and 1).

Software used to control the EUT for staying in continuous transmitting mode was programmed.

The field strength of spurious emission was measured in the following position: EUT stand-up position (Z axis), lie-down position (X, Y axis). The worst emission was found in lie-down position (Y axis) and the worst case was recorded.

After verification, all tests were carried out with the worst case test modes as shown below except radiated spurious emission below 1GHz, which worst case was in normal link mode only.

Band I

IEEE 802.11a mode / 5180 ~ 5240MHz:

Channel Low (5180MHz), Channel Mid (5220MHz) and Channel High (5240MHz) with 6Mbps data rate were chosen for full testing.

IEEE 802.11n HT 20 mode / 5180 ~ 5240MHz:

Channel Low (5180MHz), Channel Mid (5220MHz) and Channel High (5240MHz) with 6.5Mbps data rate were chosen for full testing.

IEEE 802.11n HT 40 mode / 5190 ~ 5230MHz:

Channel Low (5190MHz) and Channel High (5230MHz) with 13.5Mbps data rate were chosen for full testing.

IEEE 802.11ac VHT80 Mode for 5210MHz:

Channel (5210MHz) with 6.5Mbps data rate were chosen for full testing.

Band IV

IEEE 802.11a mode / 5745 ~ 5825MHz

Channel Low (5745MHz), Channel Mid (5785MHz) and Channel High (5825MHz) with 6Mbps data rate were chosen for full testing.

IEEE 802.11n HT 20 mode: / 5745 ~ 5825MHz

Channel Low(5745MHz), Channel Mid(5785MHz) and Channel High(5825MHz) with 6.5Mbps data rate were chosen for full testing.

IEEE 802.11n HT 40 mode / 5755 ~ 5795MHz

Channel Low(5755MHz) and Channel High(5795MHz) with 13.5Mbps data rate were chosen for full testing.

IEEE 802.11ac VHT80 Mode for 5775MHz:

Channel (5775MHz) with 6.5Mbps data rate were chosen for full testing.



4. INSTRUMENT CALIBRATION

4.1 MEASURING INSTRUMENT CALIBRATION

The measuring equipment, which was utilized in performing the tests documented herein, has been calibrated in accordance with the manufacturer's recommendations for utilizing calibration equipment, which is traceable to recognized national standards.

4.2 MEASUREMENT EQUIPMENT USED

Equipment Used for Emissions Measurement

Remark: Each piece of equipment is scheduled for calibration once a year and Loop Antenna is scheduled for calibration once three years.

Conducted Emissions Test Site				
Name of Equipment	Manufacturer	Model	Serial Number	Calibration Due
Spectrum Analyzer	Agilent	E4446A	MY43360131	03/26/2015
Power Meter	Anritsu	ML2495A	1012009	06/03/2015
Power Sensor	Anritsu	MA2411A	0917072	06/03/2015

3M Chamber Test Site				
Name of Equipment	Manufacturer	Model	Serial Number	Calibration Due
Spectrum Analyzer	Agilent	E4446A	US42510268	11/05/2014
EMI Test Receiver	R&S	ESCI	100064	02/16/2015
Pre-Amplifier	Mini-Circuits	ZFL-1000LN	SF350700823	01/11/2015
Pre-Amplifier	MITEQ	AFS44-00102650-42-10P-44	1415367	11/18/2014
Bilog Antenna	Sunol Sciences	JB3	A030105	09/30/2015
Horn Antenna	EMCO	3117	00055165	02/16/2015
Horn Antenna	EMCO	3116	2487	10/08/2015
Loop Antenna	EMCO	6502	8905/2356	06/11/2015
Turn Table	CCS	CC-T-1F	N/A	N.C.R
Antenna Tower	CCS	CC-A-1F	N/A	N.C.R
Controller	CCS	CC-C-1F	N/A	N.C.R
Site NSA	CCS	N/A	N/A	12/21/2014
Test S/W	EZ-EMC (CCS-3A1RE)			

Conducted Emission room				
Name of Equipment	Manufacturer	Model	Serial Number	Calibration Due
EMI Test Receiver	R&S	ESCI	101073	07/29/2015
LISN	R&S	ENV216	101054	06/04/2015
LISN	SCHWARZBECK	NSLK 8127	8127-541	12/09/2014
Capacitive Voltage Probe	FCC	F-CVP-1	100185	03/13/2015
Test S/W	CCS-3A1-CE			



4.3 MEASUREMENT UNCERTAINTY

PARAMETER	UNCERTAINTY
Powerline Conducted Emission	+/- 1.2575
3M Semi Anechoic Chamber / <200M	+/- 4.0138
3M Semi Anechoic Chamber / 200M~1000M	+/- 3.9483
3M Semi Anechoic Chamber / 1G~8G	+/- 2.5975
3M Semi Anechoic Chamber / 8G~18G	+/- 2.6112
3M Semi Anechoic Chamber / 18G~26G	+/- 2.7389
3M Semi Anechoic Chamber / 26G~40G	+/- 2.9683

Remark: This uncertainty represents an expanded uncertainty expressed at approximately the 95% confidence level using a coverage factor of $k=2$.



5. FACILITIES AND ACCREDITATIONS

5.1 FACILITIES

All measurement facilities used to collect the measurement data are located at

No.199, Chunghsen Road, Hsintien City, Taipei Hsien, Taiwan, R.O.C.

No.139, Wugong Rd., Wugu Dist., New Taipei City 24891, Taiwan (R.O.C.)

No.11, Wugong 6th Rd., Wugu Dist., New Taipei City 24891, Taiwan. (R.O.C.)

No.81-1, Lane 210, Bade 2nd Rd., Lujhu Township, Taoyuan County 33841, TAIWAN, R.O.C.

The sites are constructed in conformance with the requirements of ANSI C63.7, ANSI C63.4 and CISPR Publication 22.

5.2 EQUIPMENT

Radiated emissions are measured with one or more of the following types of linearly polarized antennas: tuned dipole, biconical, log periodic, bi-log, and/or ridged waveguide, horn. Spectrum analyzers with pre-selectors and quasi-peak detectors are used to perform radiated measurements.



Conducted emissions are measured with Line Impedance Stabilization Networks and EMI Test Receivers.

Calibrated wideband preamplifiers, coaxial cables, and coaxial attenuators are also used for making measurements.

All receiving equipment conforms to CISPR Publication 16-1, "Radio Interference Measuring Apparatus and Measurement Methods."



5.3 TABLE OF ACCREDITATIONS AND LISTINGS

Country	Agency	Scope of Accreditation	Logo
USA	FCC	3M Semi Anechoic Chamber (FCC MRA: TW1039) to perform FCC Part 15 measurements	 FCC MRA: TW1039
Taiwan	TAF	LP0002, RTTE01, FCC Method-47 CFR Part 15 Subpart C, D, E, RSS-210, RSS-310 IDA TS SRD, AS/NZS 4268, AS/NZS 4771, TS 12.1 & 12.2, ETSI EN 300 440-1, ETSI EN 300 440-2, ETSI EN 300 328, ETSI EN 300 220-1, ETSI EN 300 220-2, ETSI EN 301 893, ETSI EN 301 489-1/3/7/17 FCC OET Bulletin 65 + Supplement C, EN 50360, EN 50361, EN 50371, RSS 102, EN 50383, EN 50385, EN 50392, IEC 62209, CNS 14958-1, CNS 14959 FCC Method -47 CFR Part 15 Subpart B IEC / EN 61000-3-2, IEC / EN 61000-3-3, IEC / EN 61000-4-2/3/4/5/6/8/11	
Canada	Industry Canada	3M Semi Anechoic Chamber (IC 2324G-1 / IC 2324G-2) to perform	 IC 2324G-1 IC 2324G-2

* No part of this report may be used to claim or imply product endorsement by A2LA or any agency of the US Government.



6. SETUP OF EQUIPMENT UNDER TEST

6.1 SETUP CONFIGURATION OF EUT

See test photographs attached in Appendix I for the actual connections between EUT and support equipment.

6.2 SUPPORT EQUIPMENT

No.	Device Type	Brand	Model	Series No.	FCC ID	Data Cable	Power Cord
1	Notebook PC	IBM	7663 (T61)	L3E9812	N/A	N/A	AC I/P: Unshielded, 1.8m DC O/P: Unshielded, 1.8m with a core

Remark:

1. All the equipment/cables were placed in the worst-case configuration to maximize the emission during the test.
2. Grounding was established in accordance with the manufacturer's requirements and conditions for the intended use.



7. FCC PART 15 REQUIREMENTS

7.1 26 DB EMISSION BANDWIDTH

LIMIT

According to §15.303(c), for purposes of this subpart the emission bandwidth shall be determined by measuring the width of the signal between two points, one below the carrier center frequency and one above the carrier center frequency, that are 26 dB down relative to the maximum level of the modulated carrier. Compliance with the emissions limits is based on the use of measurement instrumentation employing a peak detector function with an instrument resolutions bandwidth approximately equal to 1.0 percent of the emission bandwidth of the device under measurement.

Test Configuration

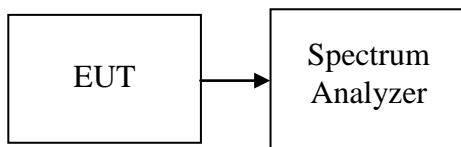

TEST PROCEDURE

1. Place the EUT on the table and set it in the transmitting mode.
2. Remove the antenna from the EUT and then connect a low-loss RF cable from the antenna port to the spectrum analyzer.
3. Set the spectrum analyzer as $RBW > 1\%EBW$, $VBW > RBW$, $Span > 26dB$ bandwidth, and Sweep = auto.
4. Mark the peak frequency and $-26dB$ (upper and lower) frequency.
5. Repeat until all the rest channels were investigated.

TEST RESULTS

No non-compliance noted



Test Data

Test mode: IEEE 802.11a mode / 5180 ~ 5240MHz

Channel	Frequency (MHz)	Bandwidth (MHz)
Low	5180	31.258
Mid	5220	37.320
High	5240	37.808

Test mode: IEEE 802.11n HT 20 mode / 5180 ~ 5240MHz

Channel	Frequency (MHz)	Chain 0 Bandwidth (MHz)	Chain 1 Bandwidth (MHz)
Low	5180	37.961	24.522
Mid	5220	40.000	33.294
High	5240	36.931	38.419

Test mode: IEEE 802.11n HT 40 mode / 5190 ~ 5230MHz

Channel	Frequency (MHz)	Chain 0 Bandwidth (MHz)	Chain 1 Bandwidth (MHz)
Low	5190	78.469	71.246
High	5230	79.740	71.856

Test mode: IEEE 802.11ac VHT80 Mode/ 5210MHz

Channel	Frequency (MHz)	Chain 0 Bandwidth (MHz)	Chain 1 Bandwidth (MHz)
Mid	5210	154.400	160.000



Test mode: IEEE 802.11a mode / 5745 ~ 5825MHz

Channel	Frequency (MHz)	Bandwidth (MHz)
Low	5745	16.459
Mid	5785	16.254
High	5825	16.709

Test mode: IEEE 802.11n HT 20 mode / 5745 ~ 5825MHz

Channel	Frequency (MHz)	Chain 0 Bandwidth (MHz)	Chain 1 Bandwidth (MHz)
Low	5745	17.285	17.376
Mid	5785	17.772	17.256
High	5825	17.432	17.129

Test mode: IEEE 802.11n HT 40 mode / 5755 ~ 5815MHz

Channel	Frequency (MHz)	Chain 0 Bandwidth (MHz)	Chain 1 Bandwidth (MHz)
Low	5755	36.347	35.979
High	5795	36.305	35.878

Test mode: IEEE 802.11ac VHT80 Mode/ 5775MHz

Channel	Frequency (MHz)	Chain 0 Bandwidth (MHz)	Chain 1 Bandwidth (MHz)
Mid	5775	75.977	75.468



Test Plot

IEEE 802.11a mode / 5180 ~ 5240MHz

CH Low

Agilent

R T

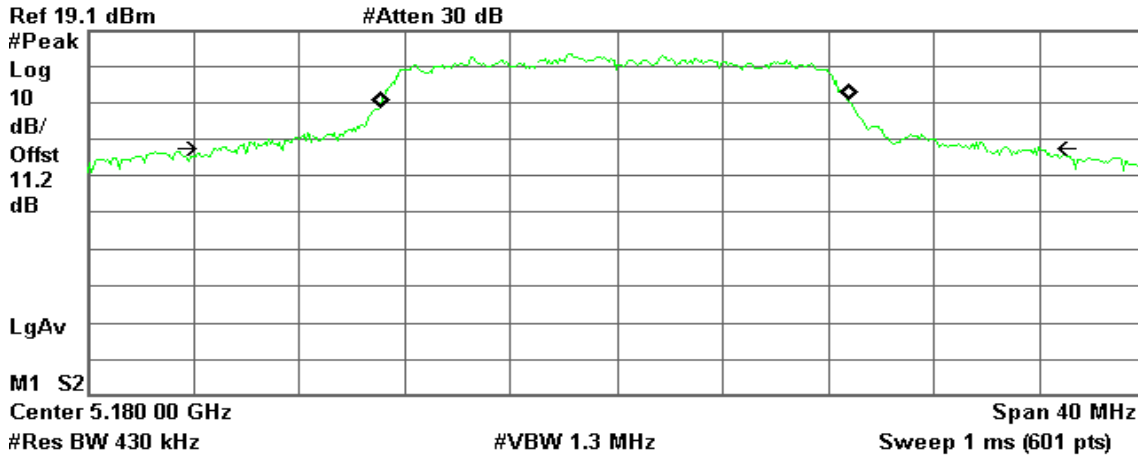

Occupied Bandwidth
17.7587 MHz

Occ BW % Pwr 99.00 %
x dB -26.00 dB

Transmit Freq Error -58.978 kHz
x dB Bandwidth 31.258 MHz

CH Mid

Agilent

R T

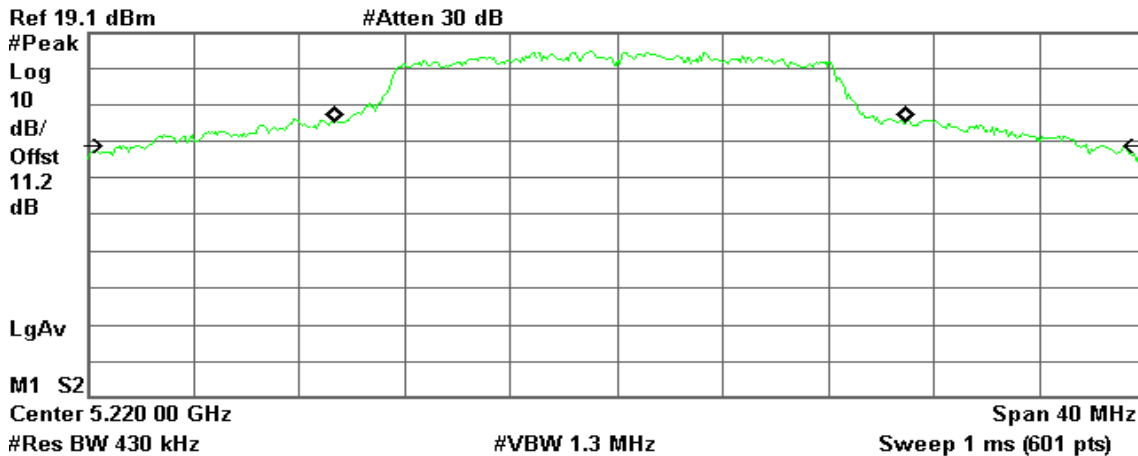

Occupied Bandwidth
21.6379 MHz

Occ BW % Pwr 99.00 %
x dB -26.00 dB

Transmit Freq Error 125.896 kHz
x dB Bandwidth 37.320 MHz



CH High

Agilent

R T

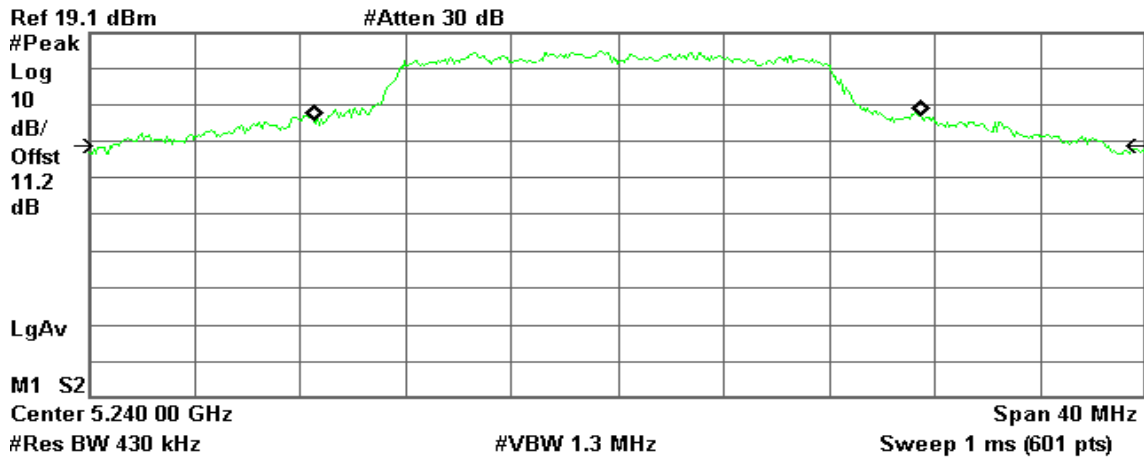

Occupied Bandwidth
22.9259 MHz

Occ BW % Pwr 99.00 %
x dB -26.00 dB

Transmit Freq Error -17.613 kHz
x dB Bandwidth 37.808 MHz



IEEE 802.11n HT 20 mode / 5180 ~ 5240MHz / Chain 0

CH Low

Agilent

R T

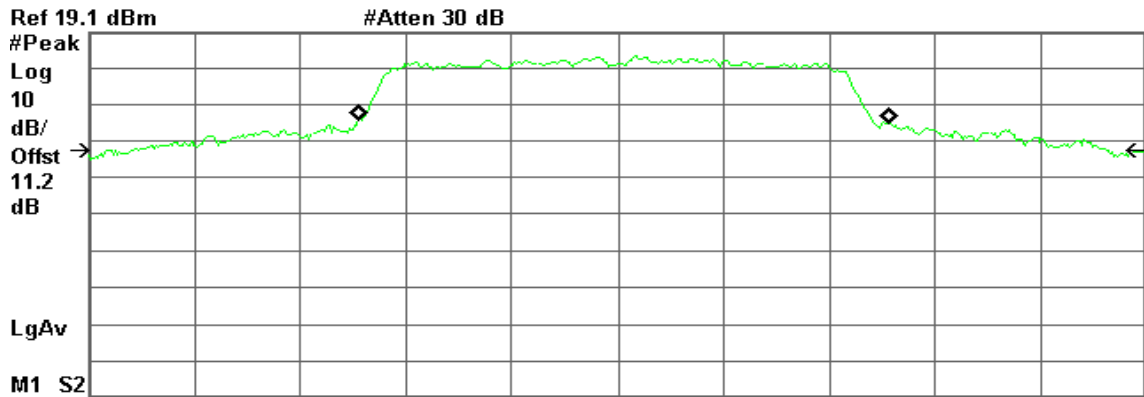

Center 5.180 00 GHz Span 40 MHz
 #Res BW 430 kHz #VBW 1.3 MHz Sweep 1 ms (601 pts)

Occupied Bandwidth
 20.1098 MHz

Occ BW % Pwr 99.00 %
 x dB -26.00 dB

Transmit Freq Error 244.095 kHz
 x dB Bandwidth 37.961 MHz

CH Mid

Agilent

R T

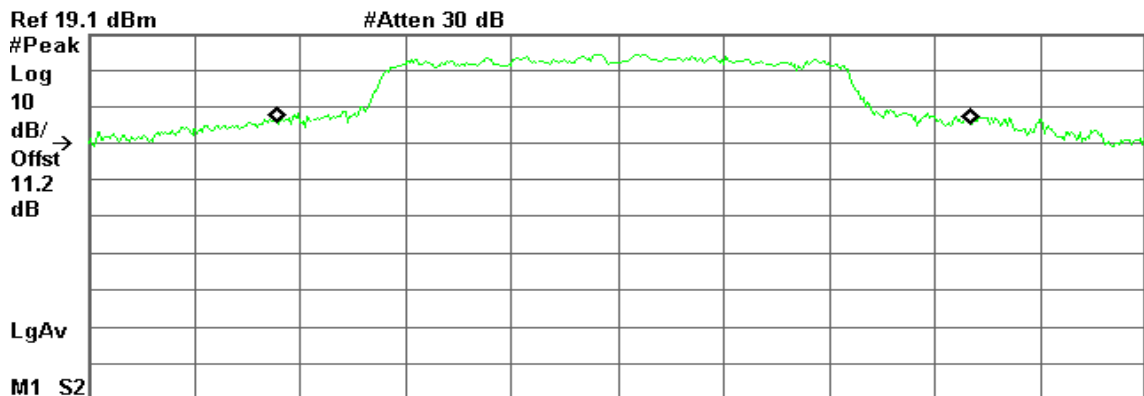

Center 5.220 00 GHz Span 40 MHz
 #Res BW 430 kHz #VBW 1.3 MHz Sweep 1 ms (601 pts)

Occupied Bandwidth
 26.2141 MHz

Occ BW % Pwr 99.00 %
 x dB -26.00 dB

Transmit Freq Error 223.616 kHz
 x dB Bandwidth 40.000 MHz



CH High

Agilent

R T

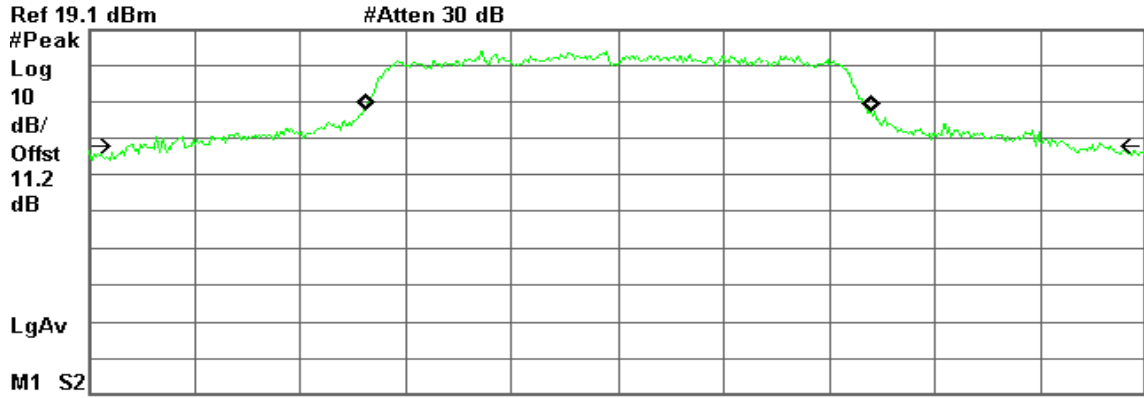

Occupied Bandwidth
19.1247 MHz

Occ BW % Pwr 99.00 %
x dB -26.00 dB

Transmit Freq Error 16.806 kHz
x dB Bandwidth 36.931 MHz



IEEE 802.11n HT 20 mode / 5180 ~ 5240MHz / Chain 1

CH Low

Agilent

R T

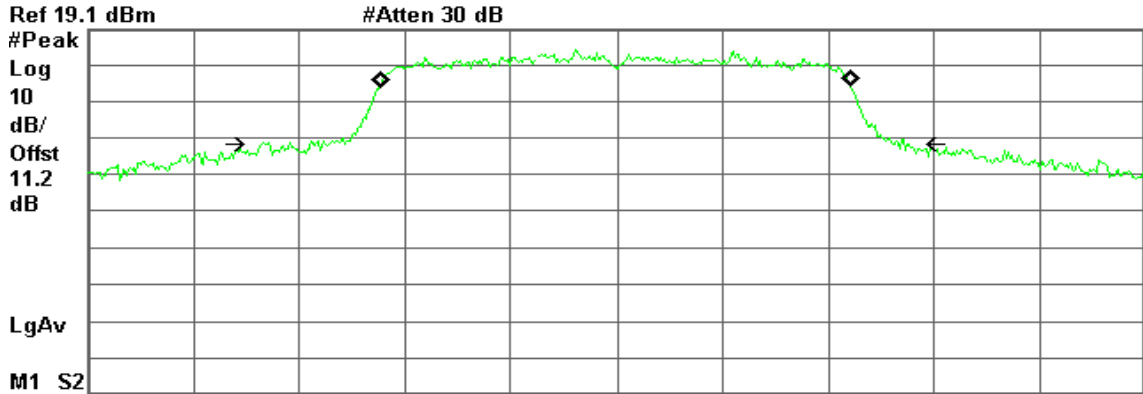

Center 5.180 00 GHz Span 40 MHz
 #Res BW 430 kHz #VBW 1.3 MHz Sweep 1 ms (601 pts)

Occupied Bandwidth
 17.7998 MHz

Occ BW % Pwr 99.00 %
 x dB -26.00 dB

Transmit Freq Error -61.381 kHz
 x dB Bandwidth 24.522 MHz

CH Mid

Agilent

R T

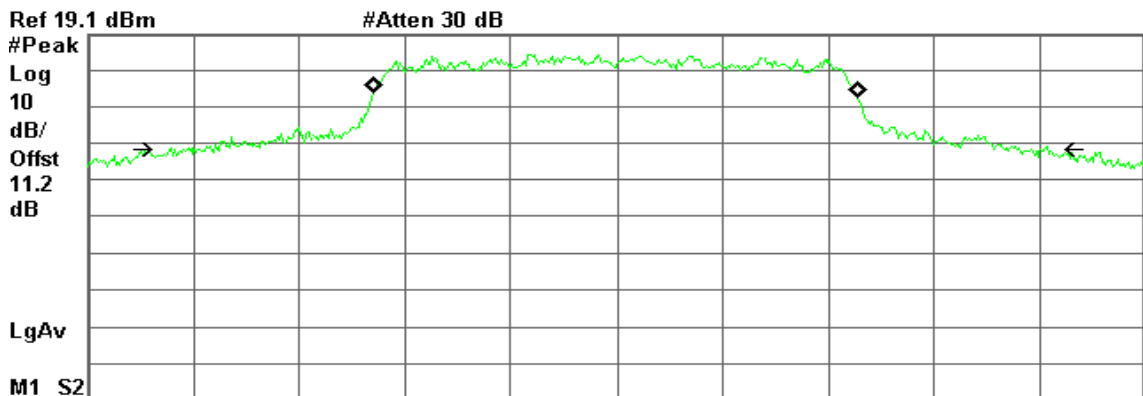

Center 5.220 00 GHz Span 40 MHz
 #Res BW 430 kHz #VBW 1.3 MHz Sweep 1 ms (601 pts)

Occupied Bandwidth
 18.3566 MHz

Occ BW % Pwr 99.00 %
 x dB -26.00 dB

Transmit Freq Error -36.839 kHz
 x dB Bandwidth 33.294 MHz



CH High

Agilent

R T

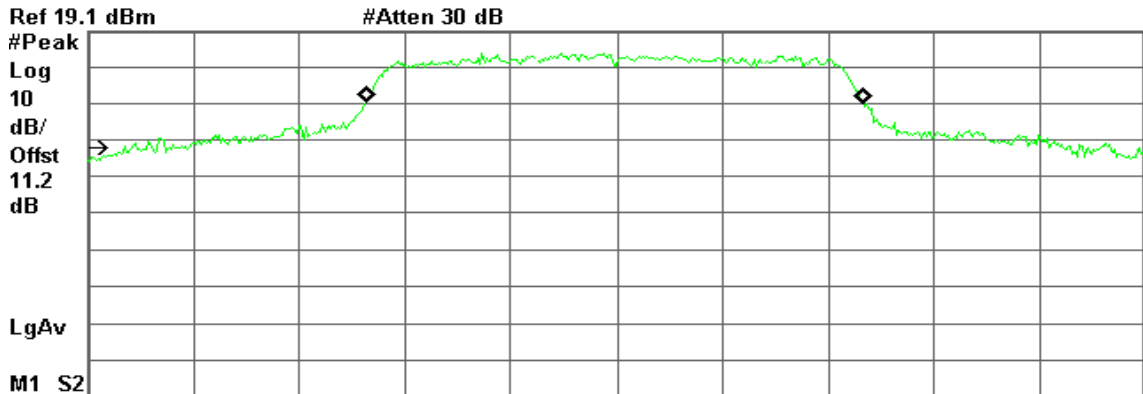

Occupied Bandwidth
18.8333 MHz

Occ BW % Pwr 99.00 %
x dB -26.00 dB

Transmit Freq Error -55.726 kHz
x dB Bandwidth 38.419 MHz



IEEE 802.11n HT 40 mode / 5190 ~ 5230MHz / Chain 0

CH Low

Agilent

R T



Occupied Bandwidth
48.0936 MHz

Occ BW % Pwr 99.00 %
x dB -26.00 dB

Transmit Freq Error 452.315 kHz
x dB Bandwidth 78.469 MHz

CH High

Agilent

R T

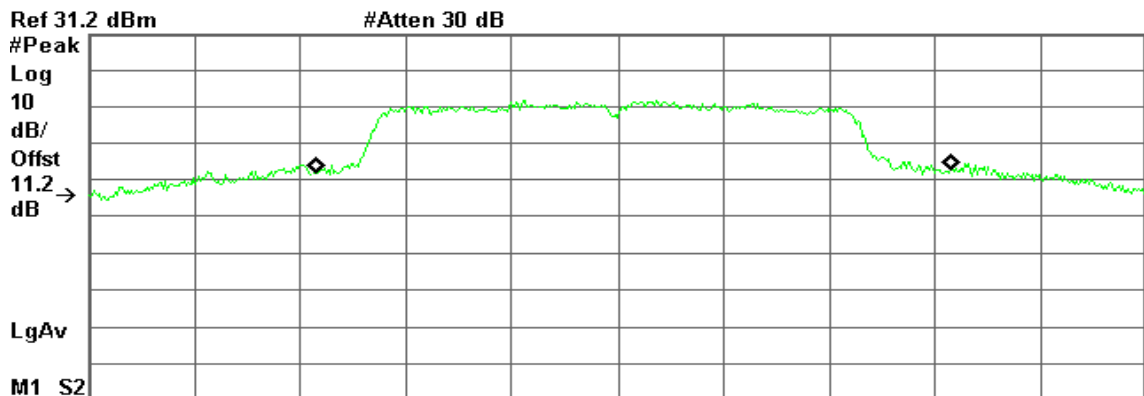

Occupied Bandwidth
48.0167 MHz

Occ BW % Pwr 99.00 %
x dB -26.00 dB

Transmit Freq Error 1.225 MHz
x dB Bandwidth 79.740 MHz



IEEE 802.11n HT 40 mode / 5190 ~ 5230MHz / Chain 1

CH Low

Agilent

R T

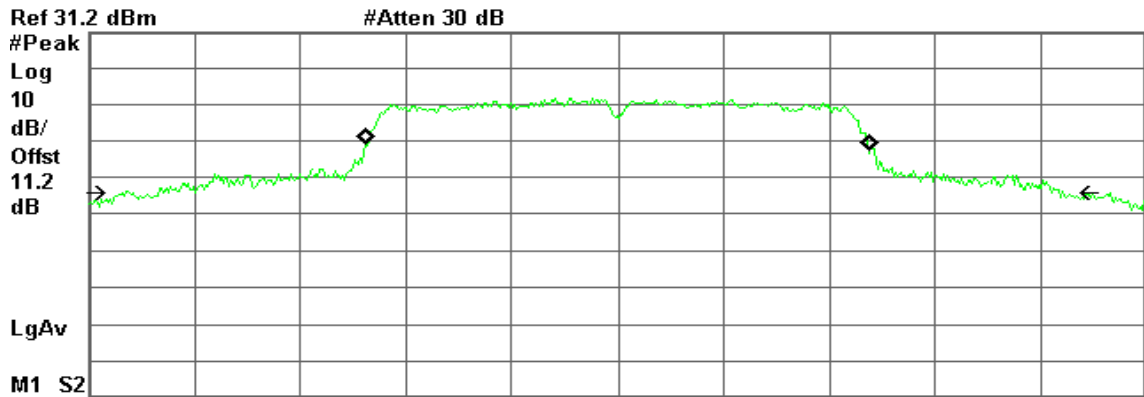

Center 5.190 00 GHz Span 80 MHz
 #Res BW 820 kHz #VBW 2.4 MHz Sweep 1 ms (601 pts)

Occupied Bandwidth
 38.1762 MHz

Occ BW % Pwr 99.00 %
 x dB -26.00 dB

Transmit Freq Error 39.955 kHz
 x dB Bandwidth 71.246 MHz

CH High

Agilent

R T

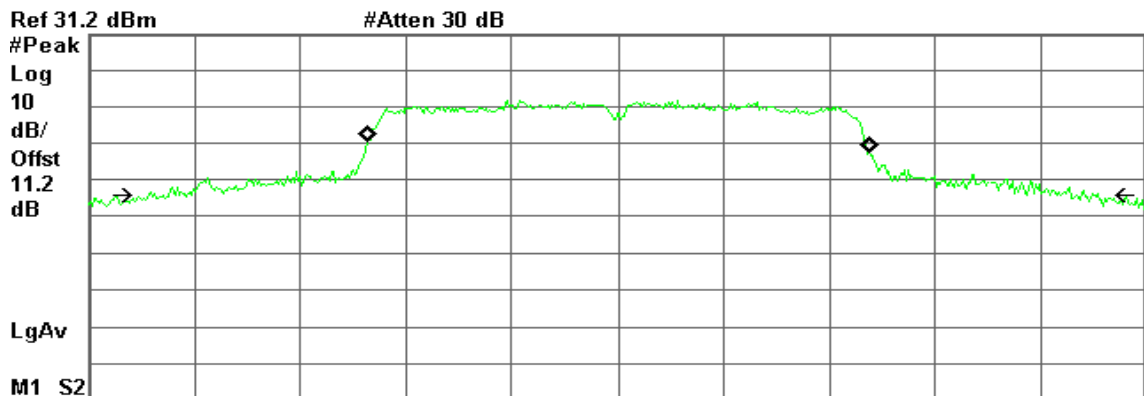

Center 5.230 00 GHz Span 80 MHz
 #Res BW 820 kHz #VBW 2.4 MHz Sweep 1 ms (601 pts)

Occupied Bandwidth
 37.9025 MHz

Occ BW % Pwr 99.00 %
 x dB -26.00 dB

Transmit Freq Error 68.107 kHz
 x dB Bandwidth 71.856 MHz



IEEE 802.11ac VHT80 Mode / 5210MHz / Chain 0

CH Mid

Agilent

R T

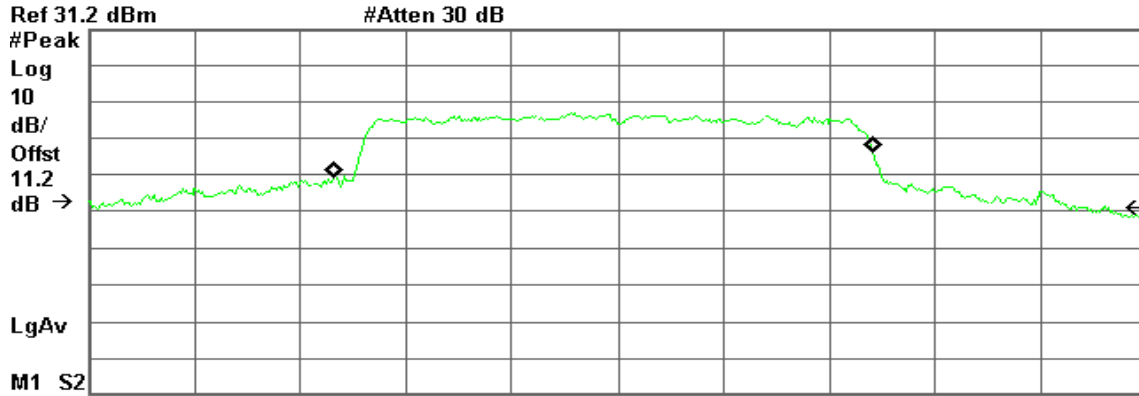

Center 5.210 0 GHz Span 160 MHz
 #Res BW 1.6 MHz #VBW 5 MHz Sweep 1 ms (601 pts)

Occupied Bandwidth
 81.5868 MHz

Occ BW % Pwr 99.00 %
 x dB -26.00 dB

Transmit Freq Error -2.066 MHz
 x dB Bandwidth 154.400 MHz

IEEE 802.11ac VHT80 Mode / 5210MHz / Chain 1

CH Mid

Agilent

R T

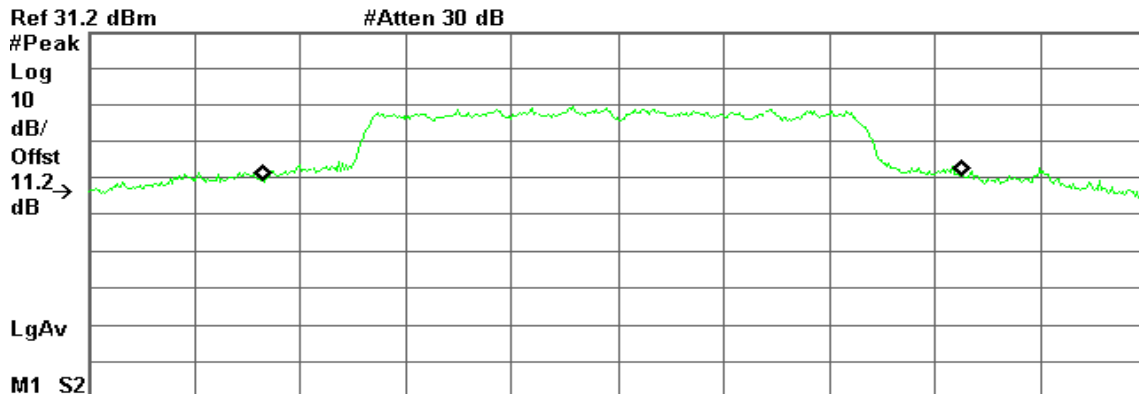

Center 5.210 0 GHz Span 160 MHz
 #Res BW 1.6 MHz #VBW 5 MHz Sweep 1 ms (601 pts)

Occupied Bandwidth
 105.7586 MHz

Occ BW % Pwr 99.00 %
 x dB -26.00 dB

Transmit Freq Error -791.768 kHz
 x dB Bandwidth 160.000 MHz



IEEE 802.11a mode / 5745 ~ 5825MHz

CH Low

Agilent

R T

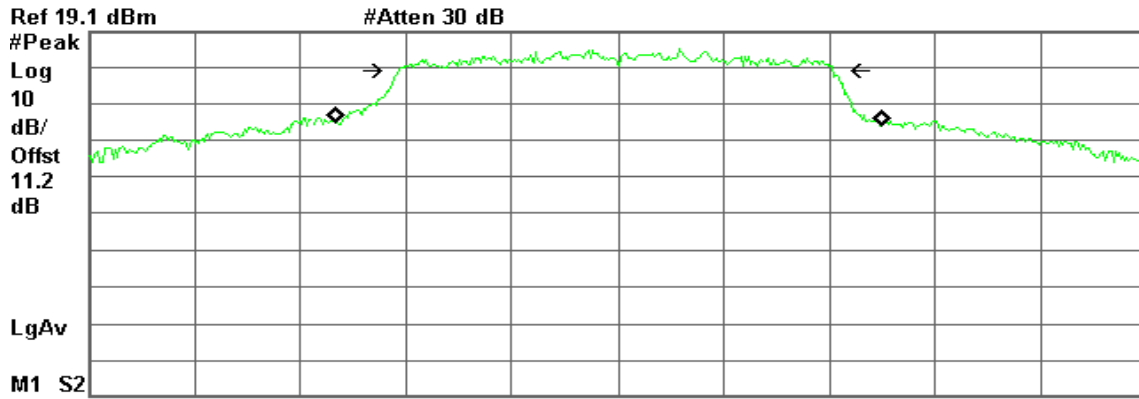

Center 5.745 00 GHz Span 40 MHz
 #Res BW 430 kHz #VBW 1.3 MHz Sweep 1 ms (601 pts)

Occupied Bandwidth 20.6630 MHz
 Occ BW % Pwr 99.00 %
 x dB -6.00 dB

Transmit Freq Error -331.879 kHz
 x dB Bandwidth 16.459 MHz

CH Mid

Agilent

R T

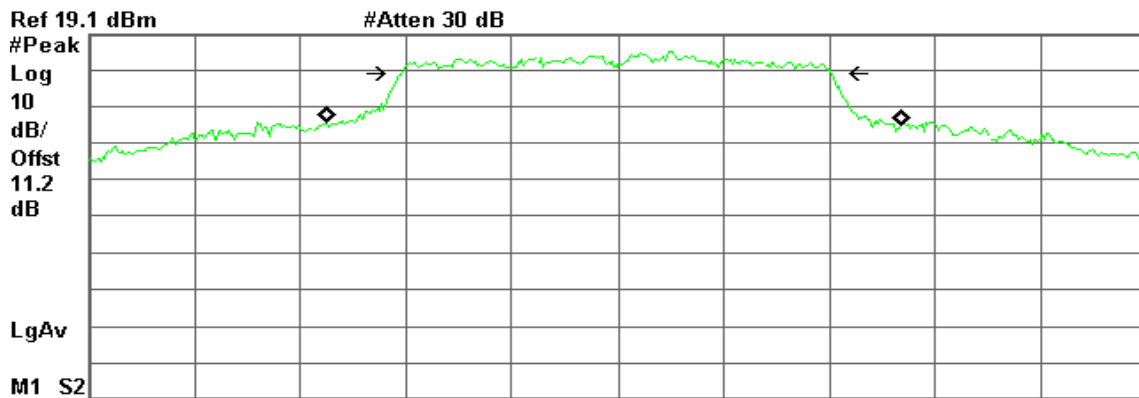

Center 5.785 00 GHz Span 40 MHz
 #Res BW 430 kHz #VBW 1.3 MHz Sweep 1 ms (601 pts)

Occupied Bandwidth 21.7286 MHz
 Occ BW % Pwr 99.00 %
 x dB -6.00 dB

Transmit Freq Error -131.180 kHz
 x dB Bandwidth 16.254 MHz



CH High

Agilent

R T

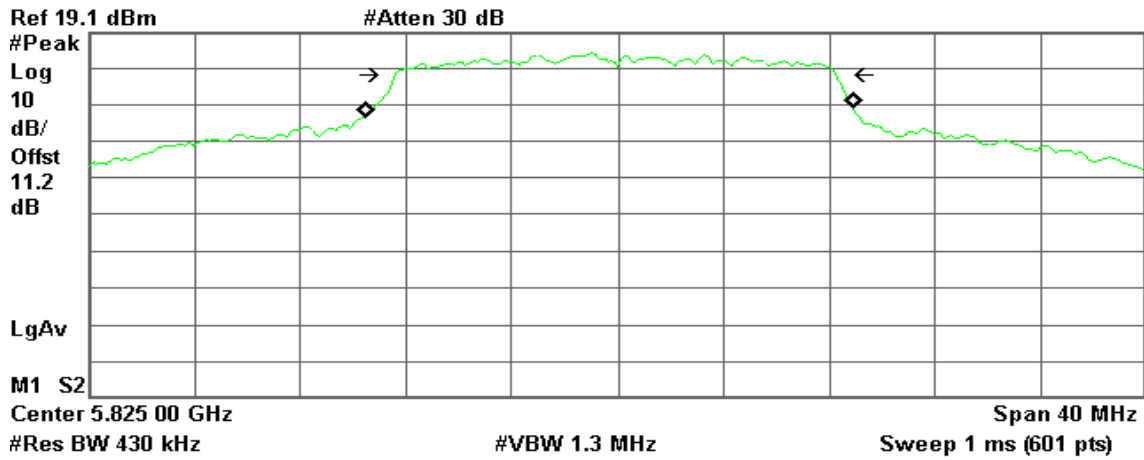

Occupied Bandwidth
18.4446 MHz

Occ BW % Pwr 99.00 %
x dB -6.00 dB

Transmit Freq Error -321.789 kHz
x dB Bandwidth 16.709 MHz



IEEE 802.11n HT 20 mode / 5745 ~ 5825MHz / Chain 0

CH Low

Agilent

R T

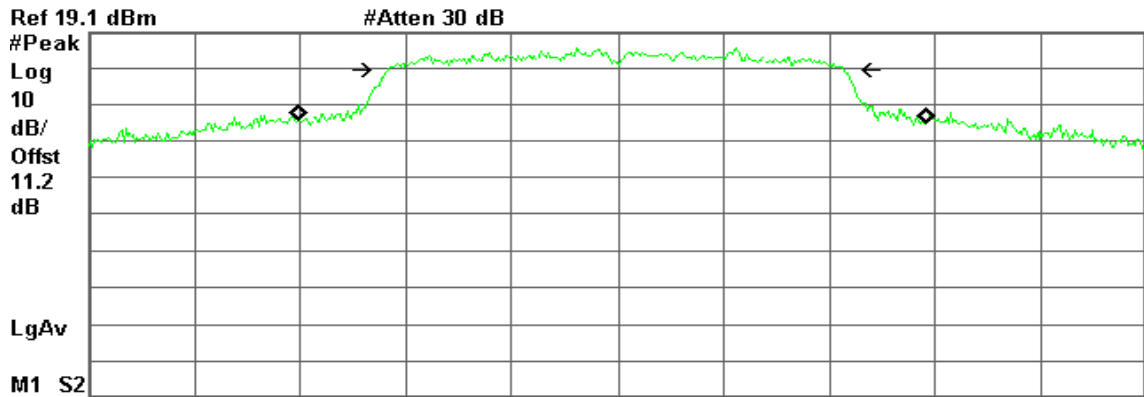

Center 5.745 00 GHz Span 40 MHz
 #Res BW 430 kHz #VBW 1.3 MHz Sweep 1 ms (601 pts)

Occupied Bandwidth Occ BW % Pwr 99.00 %
 23.7215 MHz x dB -6.00 dB

Transmit Freq Error -175.884 kHz
 x dB Bandwidth 17.285 MHz

CH Mid

Agilent

R T

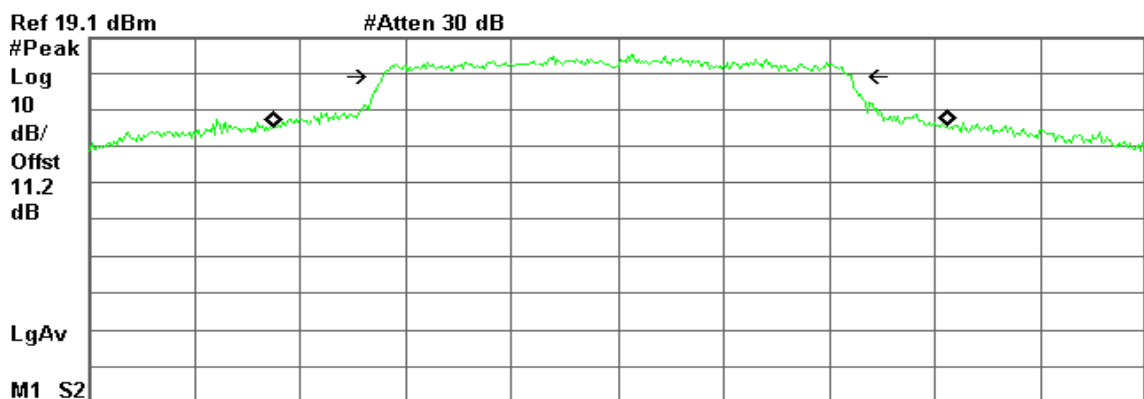

Center 5.785 00 GHz Span 40 MHz
 #Res BW 430 kHz #VBW 1.3 MHz Sweep 1 ms (601 pts)

Occupied Bandwidth Occ BW % Pwr 99.00 %
 25.4753 MHz x dB -6.00 dB

Transmit Freq Error -261.005 kHz
 x dB Bandwidth 17.772 MHz



CH High

Agilent

R T

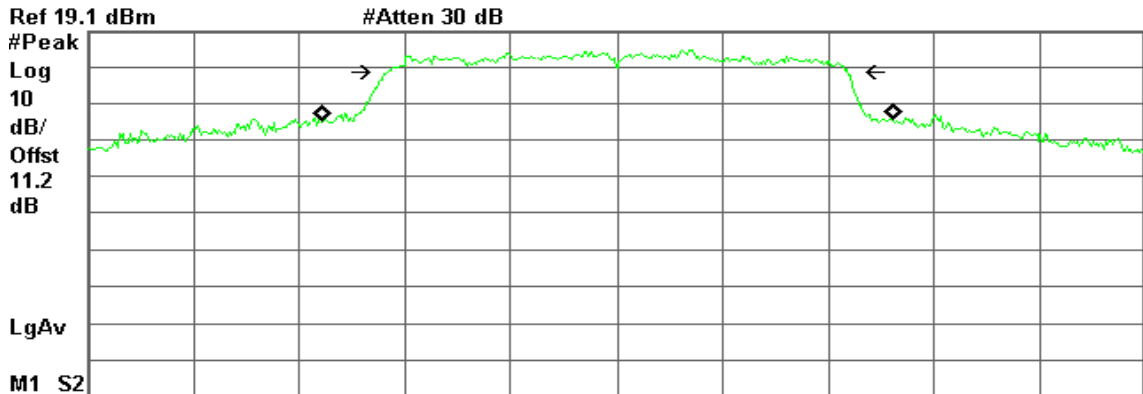

Center 5.825 00 GHz Span 40 MHz
#Res BW 430 kHz #VBW 1.3 MHz Sweep 1 ms (601 pts)

Occupied Bandwidth
21.6008 MHz

Occ BW % Pwr 99.00 %
x dB -6.00 dB

Transmit Freq Error -343.603 kHz
x dB Bandwidth 17.432 MHz



IEEE 802.11n HT 20 mode / 5745 ~ 5825MHz / Chain 1

CH Low

Agilent

R T

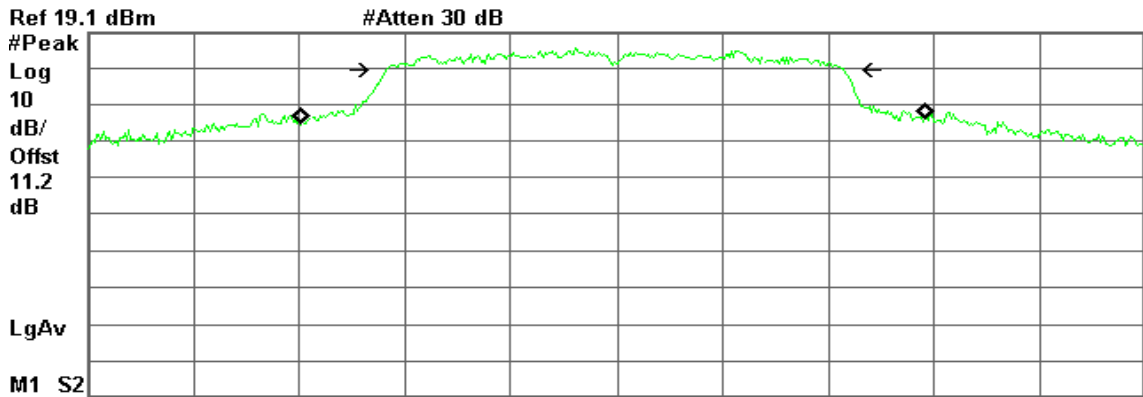

Center 5.745 00 GHz Span 40 MHz
 #Res BW 430 kHz #VBW 1.3 MHz Sweep 1 ms (601 pts)

Occupied Bandwidth
23.6217 MHz

Occ BW % Pwr 99.00 %
 x dB -6.00 dB

Transmit Freq Error -138.177 kHz
 x dB Bandwidth 17.376 MHz

CH Mid

Agilent

R T

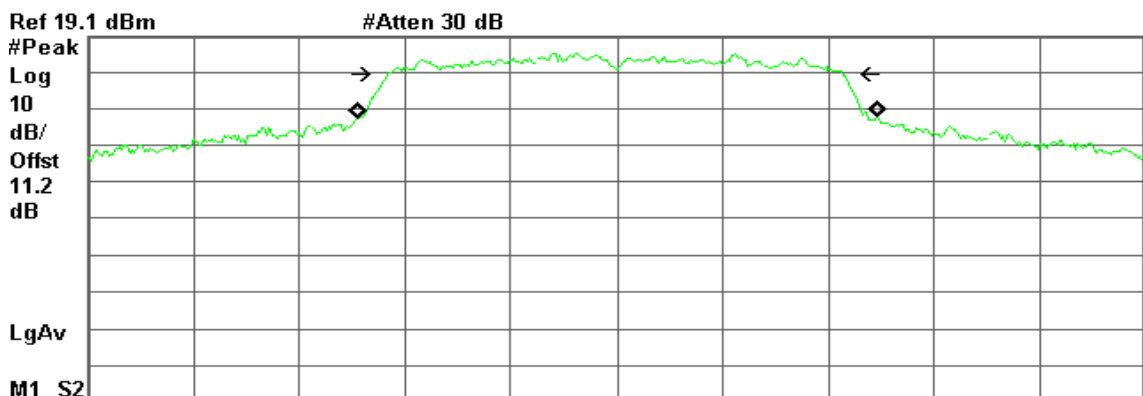

Center 5.785 00 GHz Span 40 MHz
 #Res BW 430 kHz #VBW 1.3 MHz Sweep 1 ms (601 pts)

Occupied Bandwidth
19.6371 MHz

Occ BW % Pwr 99.00 %
 x dB -6.00 dB

Transmit Freq Error 44.263 kHz
 x dB Bandwidth 17.256 MHz



CH High

Agilent

R T



Center 5.825 00 GHz Span 40 MHz
 #Res BW 430 kHz #VBW 1.3 MHz Sweep 1 ms (601 pts)

Occupied Bandwidth
 20.8672 MHz

Occ BW % Pwr 99.00 %
 x dB -6.00 dB

Transmit Freq Error 168.702 kHz
 x dB Bandwidth 17.129 MHz



IEEE 802.11n HT 40 mode / 5755 ~ 5795MHz / Chain 0

CH Low

Agilent

R T

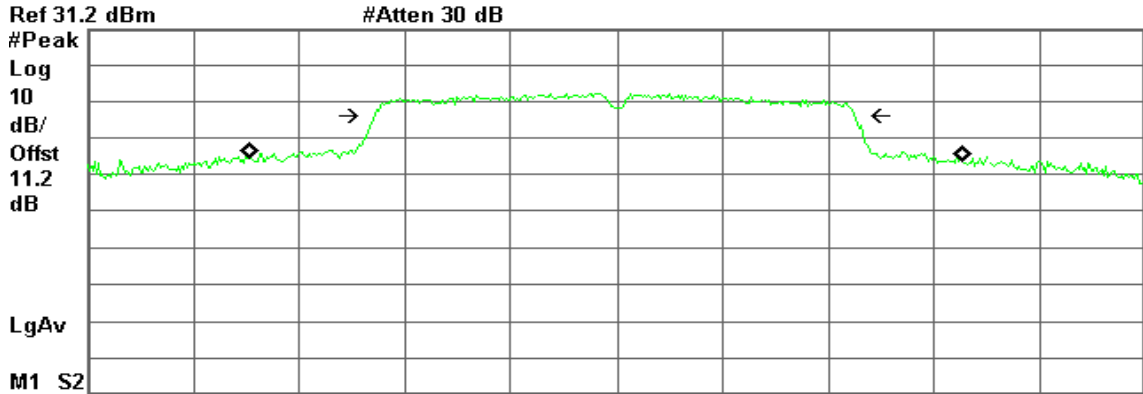

Center 5.755 00 GHz Span 80 MHz
 #Res BW 820 kHz #VBW 2.4 MHz Sweep 1 ms (601 pts)

Occupied Bandwidth
53.8265 MHz

Occ BW % Pwr 99.00 %
 x dB -6.00 dB

Transmit Freq Error -783.931 kHz
 x dB Bandwidth 36.347 MHz

CH High

Agilent

R T

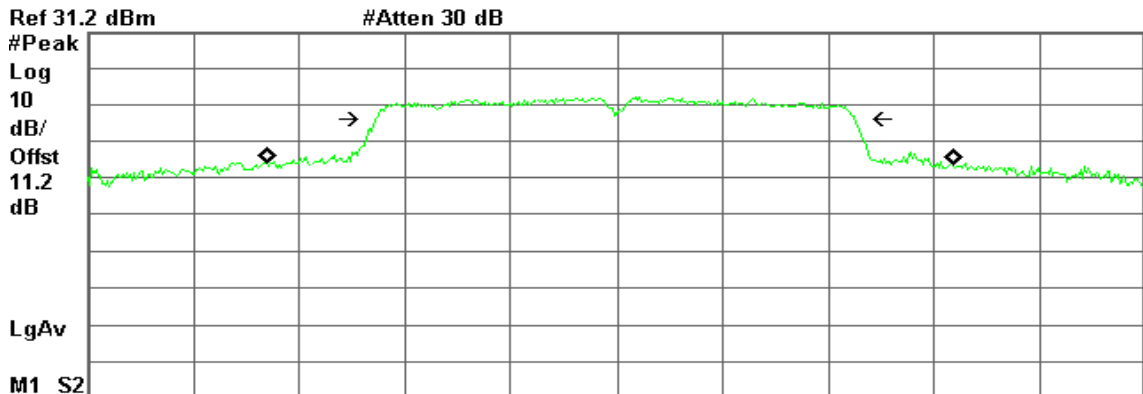

Center 5.795 00 GHz Span 80 MHz
 #Res BW 820 kHz #VBW 2.4 MHz Sweep 1 ms (601 pts)

Occupied Bandwidth
51.9146 MHz

Occ BW % Pwr 99.00 %
 x dB -6.00 dB

Transmit Freq Error -502.187 kHz
 x dB Bandwidth 36.305 MHz



IEEE 802.11n HT 40 mode / 5755 ~ 5795MHz / Chain 1

CH Low

Agilent

R T

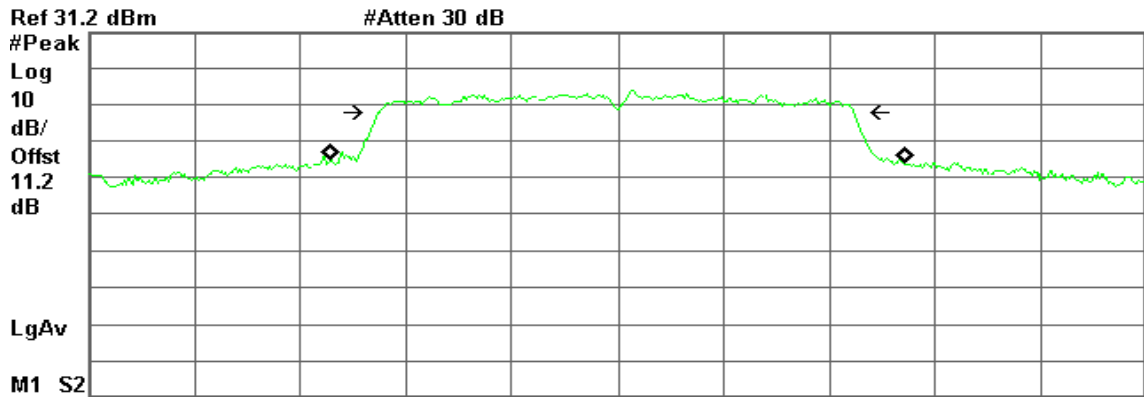

Center 5.755 00 GHz Span 80 MHz
 #Res BW 820 kHz #VBW 2.4 MHz Sweep 1 ms (601 pts)

Occupied Bandwidth
 43.3580 MHz

Occ BW % Pwr 99.00 %
 x dB -6.00 dB

Transmit Freq Error 2.702 kHz
 x dB Bandwidth 35.979 MHz

CH High

Agilent

R T

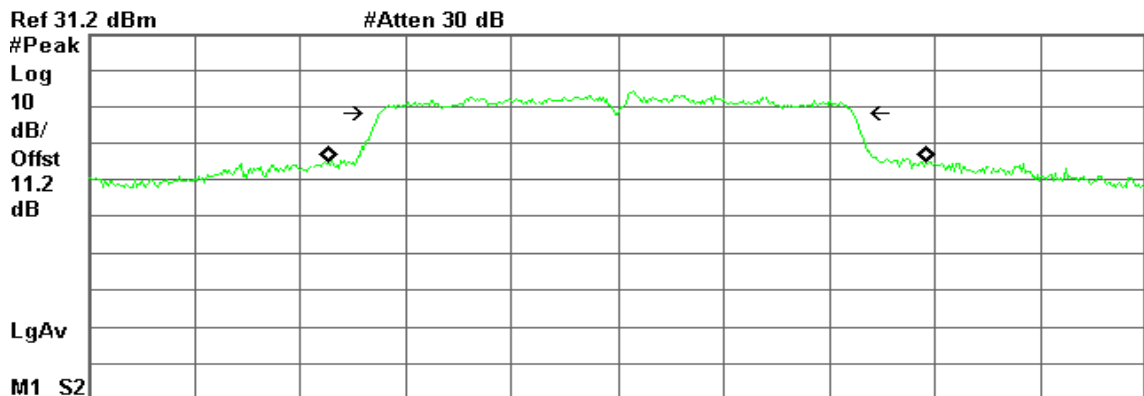

Center 5.795 00 GHz Span 80 MHz
 #Res BW 820 kHz #VBW 2.4 MHz Sweep 1 ms (601 pts)

Occupied Bandwidth
 45.2845 MHz

Occ BW % Pwr 99.00 %
 x dB -6.00 dB

Transmit Freq Error 712.297 kHz
 x dB Bandwidth 35.878 MHz



IEEE 802.11ac VHT80 Mode / 5775MHz / Chain 0

CH Mid

Agilent

R T

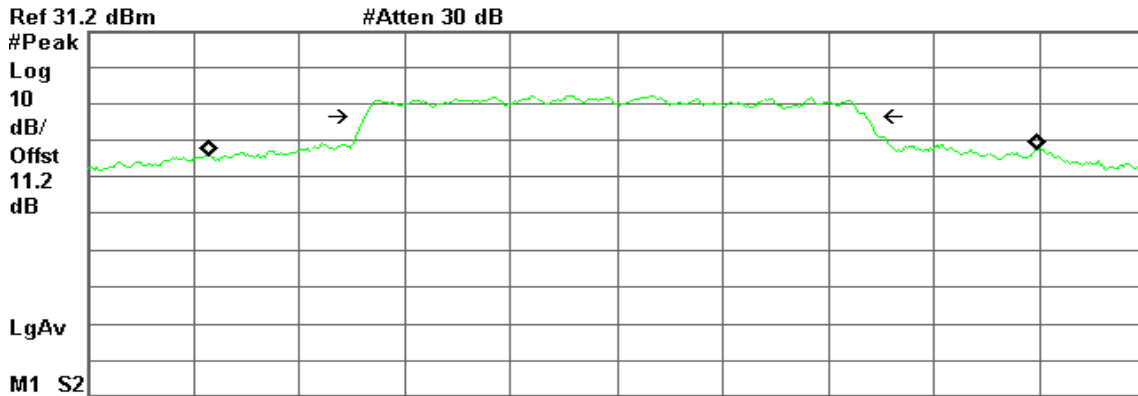

Center 5.775 0 GHz Span 160 MHz
 #Res BW 1.6 MHz #VBW 5 MHz Sweep 1 ms (601 pts)

Occupied Bandwidth
 124.9445 MHz

Occ BW % Pwr 99.00 %
 x dB -6.00 dB

Transmit Freq Error 914.966 kHz
 x dB Bandwidth 75.977 MHz

IEEE 802.11ac VHT80 Mode / 5775MHz / Chain 1

CH Mid

Agilent

R T

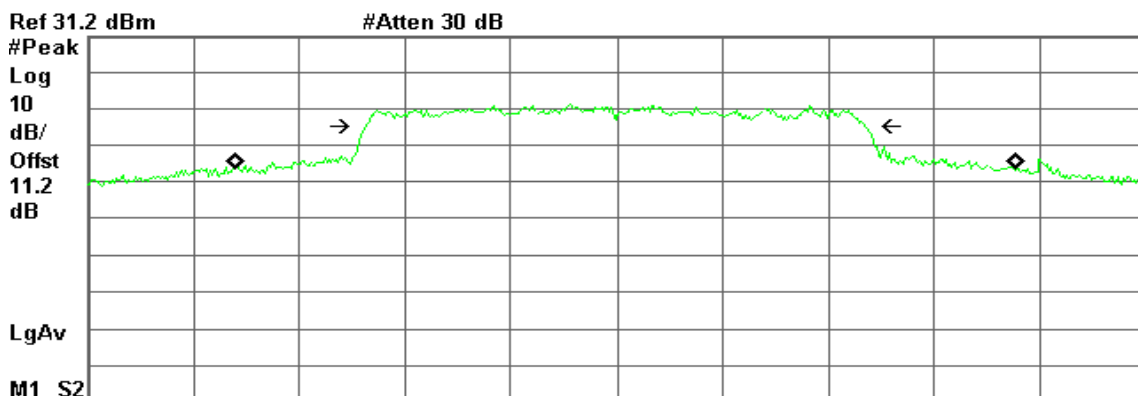

Center 5.775 0 GHz Span 160 MHz
 #Res BW 1.6 MHz #VBW 5 MHz Sweep 1 ms (601 pts)

Occupied Bandwidth
 117.7841 MHz

Occ BW % Pwr 99.00 %
 x dB -6.00 dB

Transmit Freq Error 1.251 MHz
 x dB Bandwidth 75.468 MHz



7.2 MAXIMUM CONDUCTED OUTPUT POWER

LIMIT

According to §15.407(a),

- (1) For the band 5.15-5.25 GHz, the maximum conducted output power over the frequency band of operation shall not exceed the lesser of 50 mW or $4 \text{ dBm} + 10 \log B$, where B is the 26 dB emission bandwidth in MHz.
- (2) For the 5.25-5.35 GHz and 5.47-5.725 GHz bands, the maximum conducted output power over the frequency bands of operation shall not exceed the lesser of 250 mW or $11 \text{ dBm} + 10 \log B$, where B is the 26 dB emission bandwidth in MHz.

If transmitting antennas of directional gain greater than 6dBi are used, both the peak transmit power and the peak power spectral density shall be reduced by the amount in dB that the directional gain of the antenna exceeds 6dBi.

The peak power shall not exceed the limit as follow:

Specified Limit of the Peak Power

Test mode: IEEE 802.11a mode / 5180 ~ 5240MHz

Channel	Frequency (MHz)	26 dB Bandwidth (B) (MHz)	10 Log B (dB)	4 + 10 Log B (dBm)	Maximum Conducted Output Power Limit (dBm)
Low	5180	31.258	14.94961	18.9496	30.00
Mid	5220	37.320	15.71942	19.7194	30.00
High	5240	37.808	15.77584	19.7758	30.00

Test mode: IEEE 802.11n HT 20 mode / 5180 ~ 5240MHz

Channel	Frequency (MHz)	Chain 0 26 dB Bandwidth (B) (MHz)	Chain 1 26 dB Bandwidth (B) (MHz)	10 Log B (dB)	4 + 10 Log B (dBm)	Maximum Conducted Output Power Limit (dBm)
Low	5180	37.961	24.522	15.7934	19.7934	30.00
Mid	5220	40.000	33.294	16.0206	20.0206	30.00
High	5240	36.931	38.419	15.8455	19.8455	30.00

Test mode: IEEE 802.11n HT 40 mode / 5190 ~ 5230MHz

Channel	Frequency (MHz)	Chain 0 26 dB Bandwidth (B) (MHz)	Chain 1 26 dB Bandwidth (B) (MHz)	10 Log B (dB)	4 + 10 Log B (dBm)	Maximum Conducted Output Power Limit (dBm)
Low	5190	78.469	71.246	18.9470	22.9470	30.00
High	5230	79.740	71.856	19.0168	23.0168	30.00

Test mode: IEEE 802.11ac VHT80 Mode / 5210MHz

Channel	Frequency (MHz)	Chain 0 26 dB Bandwidth (B) (MHz)	Chain 1 26 dB Bandwidth (B) (MHz)	10 Log B (dB)	4 + 10 Log B (dBm)	Maximum Conducted Output Power Limit (dBm)
Mid	5210	154.400	160.000	22.0412	26.0412	30.00



Test mode: IEEE 802.11a mode / 5745 ~ 5825MHz

Channel	Frequency (MHz)	26 dB Bandwidth (B) (MHz)	10 Log B (dB)	11 + 10 Log B (dBm)	Maximum Conducted Output Power Limit (dBm)
Low	5745	16.459	12.16403	23.1640	30.00
Mid	5785	16.254	12.10960	23.1096	30.00
High	5825	16.709	12.22950	23.2295	30.00

Test mode: IEEE 802.11n HT 20 mode / 5745 ~ 5825MHz

Channel	Frequency (MHz)	Chain 0 26 dB Bandwidth (B) (MHz)	Chain 1 26 dB Bandwidth (B) (MHz)	10 Log B (dB)	11 + 10 Log B (dBm)	Maximum Conducted Output Power Limit (dBm)
Low	5745	17.285	17.376	12.3995	23.3995	30.00
Mid	5785	17.772	17.256	12.4974	23.4974	30.00
High	5825	17.432	17.129	12.4135	23.4135	30.00

Test mode: IEEE 802.11n HT 40 mode / 5755 ~ 5795MHz

Channel	Frequency (MHz)	Chain 0 26 dB Bandwidth (B) (MHz)	Chain 1 26 dB Bandwidth (B) (MHz)	10 Log B (dB)	11 + 10 Log B (dBm)	Maximum Conducted Output Power Limit (dBm)
Low	5755	36.347	35.979	15.6047	26.6047	30.00
High	5795	36.305	35.878	15.5997	26.5997	30.00

Test mode: IEEE 802.11ac VHT80 Mode / 5775MHz

Channel	Frequency (MHz)	Chain 0 26 dB Bandwidth (B) (MHz)	Chain 1 26 dB Bandwidth (B) (MHz)	10 Log B (dB)	11 + 10 Log B (dBm)	Maximum Conducted Output Power Limit (dBm)
Mid	5775	75.977	75.468	18.8068	29.8068	30.00



Test Configuration

The EUT was connected to a spectrum analyzer through a 50Ω RF cable.

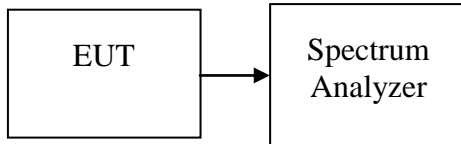

TEST PROCEDURE

Set span to encompass the entire emission bandwidth (EBW) of the signal.

Set RBW = 1 MHz / Set VBW = 3 MHz.

Use sample detector mode if bin width (i.e., span/number of points in spectrum display) < 0.5 RBW. Otherwise use peak detector mode. Use a video trigger with the trigger level set to enable triggering only on full power pulses. Transmitter must operate at full control power for entire sweep of every sweep. If the device transmits continuously, with no off intervals or reduced power intervals, the trigger may be set to “free run”. Trace average 100 traces in power averaging mode. Compute power by integrating the spectrum across the 26 dB EBW of the signal. The integration can be performed using the spectrum analyzer’s band power measurement function with band limits set equal to the EBW band edges or by summing power levels in each 1 MHz band in linear power terms. The 1 MHz band power levels to be summed can be obtained by averaging, in linear power terms, power levels in each frequency bin across the 1 MHz.

TEST RESULTS

No non-compliance noted

**Test Data****Test mode: IEEE 802.11a mode / 5180 ~ 5240MHz**

Channel	Frequency (MHz)	Maximum Conducted Output Power (dBm)	Limit (dBm)
Low	5180	16.95	30.00
Mid	5220	16.6	30.00
High	5240	16.5	30.00

Test mode: IEEE 802.11n HT 20 mode / 5180 ~ 5240MHz

Channel	Frequency (MHz)	Chain 0 Output Power (dBm)	Chain 1 Output Power (dBm)	Total Maximum Conducted Output Power (dBm)	Limit (dBm)
Low	5180	14.75	13.22	17.07	30.00
Mid	5220	14.99	14.31	17.68	30.00
High	5240	15.15	14.36	17.79	30.00

Test mode: IEEE 802.11n HT 40 mode / 5190 ~ 5230MHz

Channel	Frequency (MHz)	Chain 0 Output Power (dBm)	Chain 1 Output Power (dBm)	Total Maximum Conducted Output Power (dBm)	Limit (dBm)
Low	5190	14.76	12.72	16.87	30.00
High	5230	14.17	13.41	16.82	30.00

Test mode: IEEE 802.11ac VHT80 Mode / 5210MHz

Channel	Frequency (MHz)	Chain 0 Output Power (dBm)	Chain 1 Output Power (dBm)	Total Maximum Conducted Output Power (dBm)	Limit (dBm)
Mid	5210	15.23	14.76	18.01	30.00

Remark:

1. Total Output Power (w) = Chain 0 ($10^{(Output\ Power / 10) / 1000}$) + Chain 1 ($10^{(Output\ Power / 10) / 1000}$)

2. The maximum antenna gain is 7.09dBi; therefore the reduction due to antenna gain is 1dB, so the limit is 16dBm.

**Test mode: IEEE 802.11a mode / 5745 ~ 5825MHz**

Channel	Frequency (MHz)	Maximum Conducted Output Power (dBm)	Limit (dBm)
Low	5745	18.68	30.00
Mid	5785	18.42	30.00
High	5825	18.33	30.00

Test mode: IEEE 802.11n HT 20 mode / 5260 ~ 5320MHz

Channel	Frequency (MHz)	Chain 0 Output Power (dBm)	Chain 1 Output Power (dBm)	Total Maximum Conducted Output Power (dBm)	Limit (dBm)
Low	5745	17.26	13.09	18.67	30.00
Mid	5785	16.09	13.75	18.09	30.00
High	5825	15.39	13.31	17.49	30.00

Test mode: IEEE 802.11n HT 40 mode / 5270 ~ 5310MHz

Channel	Frequency (MHz)	Chain 0 Output Power (dBm)	Chain 1 Output Power (dBm)	Total Maximum Conducted Output Power (dBm)	Limit (dBm)
Low	5755	17.23	13.13	18.66	30.00
High	5795	16.92	12.01	18.14	30.00

Test mode: IEEE 802.11ac VHT80 Mode / 5775MHz

Channel	Frequency (MHz)	Chain 0 Output Power (dBm)	Chain 1 Output Power (dBm)	Total Maximum Conducted Output Power (dBm)	Limit (dBm)
Mid	5775	16.94	12.58	18.30	30.00

Remark:

1. Total Output Power (w) = Chain 0 (10^(Output Power /10)/1000) + Chain 1 (10^(Output Power /10)/1000)
2. The maximum antenna gain is 7.09dBi; therefore the reduction due to antenna gain is 1dB, so the limit is 23dBm.



7.3 BAND EDGES MEASUREMENT

LIMIT

According to §15.407(b),

- (1) The provisions of Section 15.205 of this part apply to intentional radiators operating under this section.
- (2) When measuring the emission limits, the nominal carrier frequency shall be adjusted as close to the upper and lower frequency block edges as the design of the equipment permits.

Test Configuration

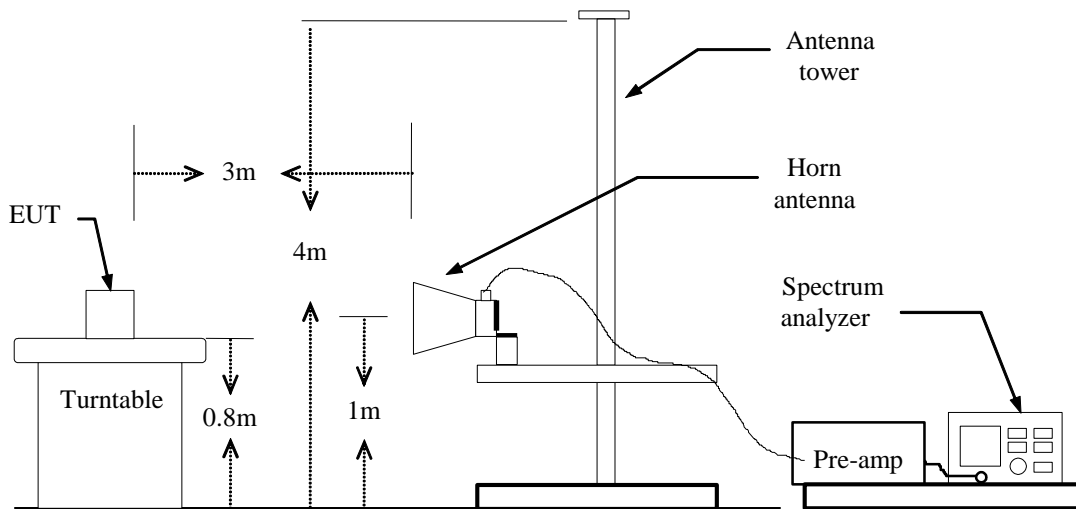

TEST PROCEDURE

1. The EUT is placed on a turntable, which is 0.8m above the ground plane.
2. The turntable shall be rotated for 360 degrees to determine the position of maximum emission level.
3. EUT is set 3m away from the receiving antenna, which is varied from 1m to 4m to find out the highest emission.
4. Set the spectrum analyzer in the following setting in order to capture the lower and upper band-edges of the emission:
 - (a) PEAK: RBW=VBW=1MHz / Sweep=AUTO
 - (b) AVERAGE: RBW=1MHz / VBW=300Hz / Sweep=AUTO
5. Repeat the procedures until all the PEAK and AVERAGE versus POLARIZATION are measured.

TEST RESULTS

Refer to attach spectrum analyzer data chart.



Band Edges (IEEE 802.11a mode / 5180 MHz)

Polarity: Vertical

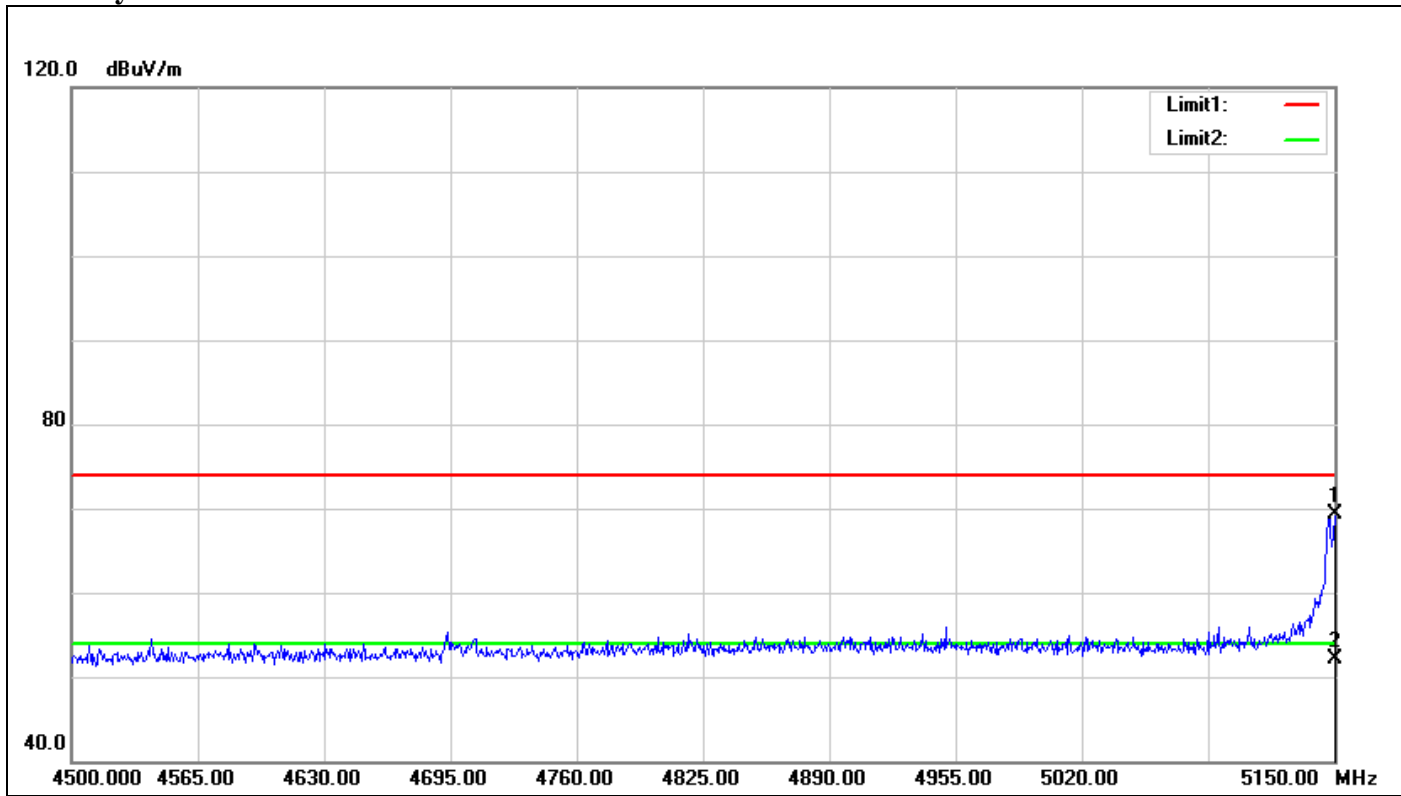

No.	Frequency (MHz)	Reading (dBuV)	Correct Factor(dB/m)	Result (dBuV/m)	Limit (dBuV/m)	Margin (dB)	Height (cm)	Degree (°)	Remark
1	5150.000	66.24	3.04	69.28	74.00	-4.72	100	86	peak
2	5150.000	49.03	3.04	52.07	54.00	-1.93	100	86	AVG



Polarity: Horizontal

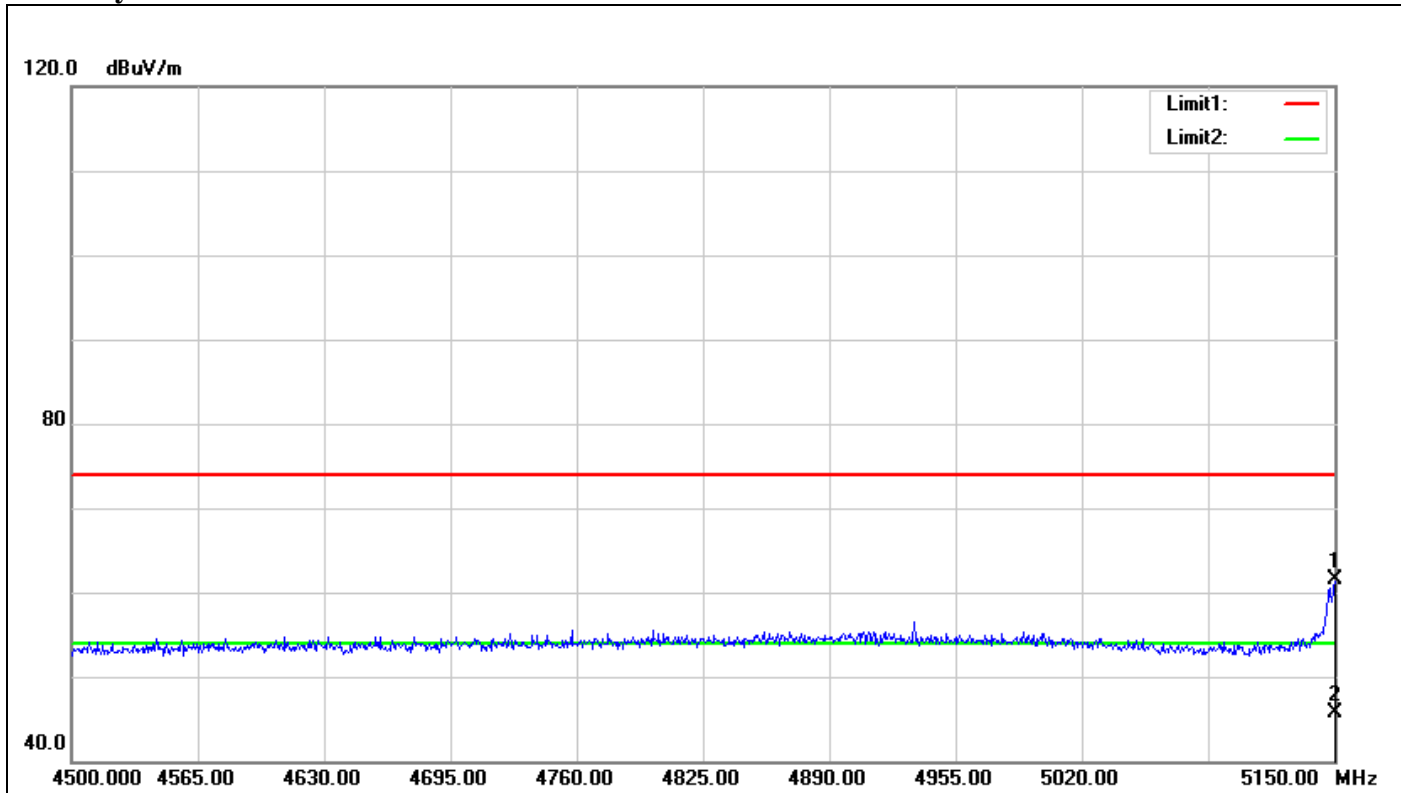

No.	Frequency (MHz)	Reading (dBuV)	Correct Factor(dB/m)	Result (dBuV/m)	Limit (dBuV/m)	Margin (dB)	Height (cm)	Degree (°)	Remark
1	5150.000	58.52	3.04	61.56	74.00	-12.44	100	123	peak
2	5150.000	42.65	3.04	45.69	54.00	-8.31	100	123	AVG



Band Edges (IEEE 802.11n HT 20 mode / 5180 MHz)

Polarity: Vertical

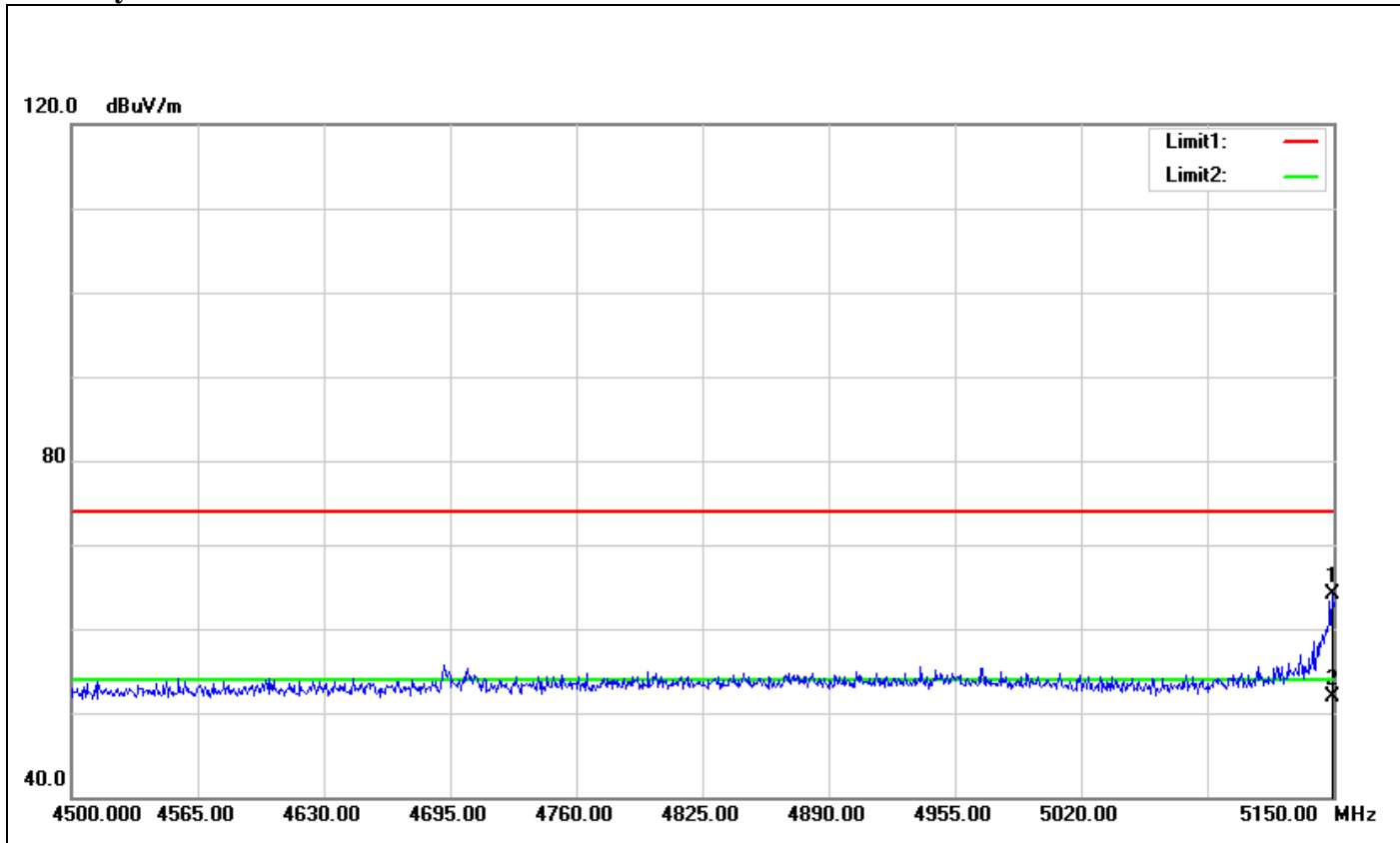

No.	Frequency (MHz)	Reading (dBuV)	Correct Factor(dB/m)	Result (dBuV/m)	Limit (dBuV/m)	Margin (dB)	Height (cm)	Degree (°)	Remark
1	5149.350	61.08	3.04	64.12	74.00	-9.88	100	186	peak
2	5149.350	48.89	3.04	51.93	54.00	-2.07	100	186	AVG



Polarity: Horizontal

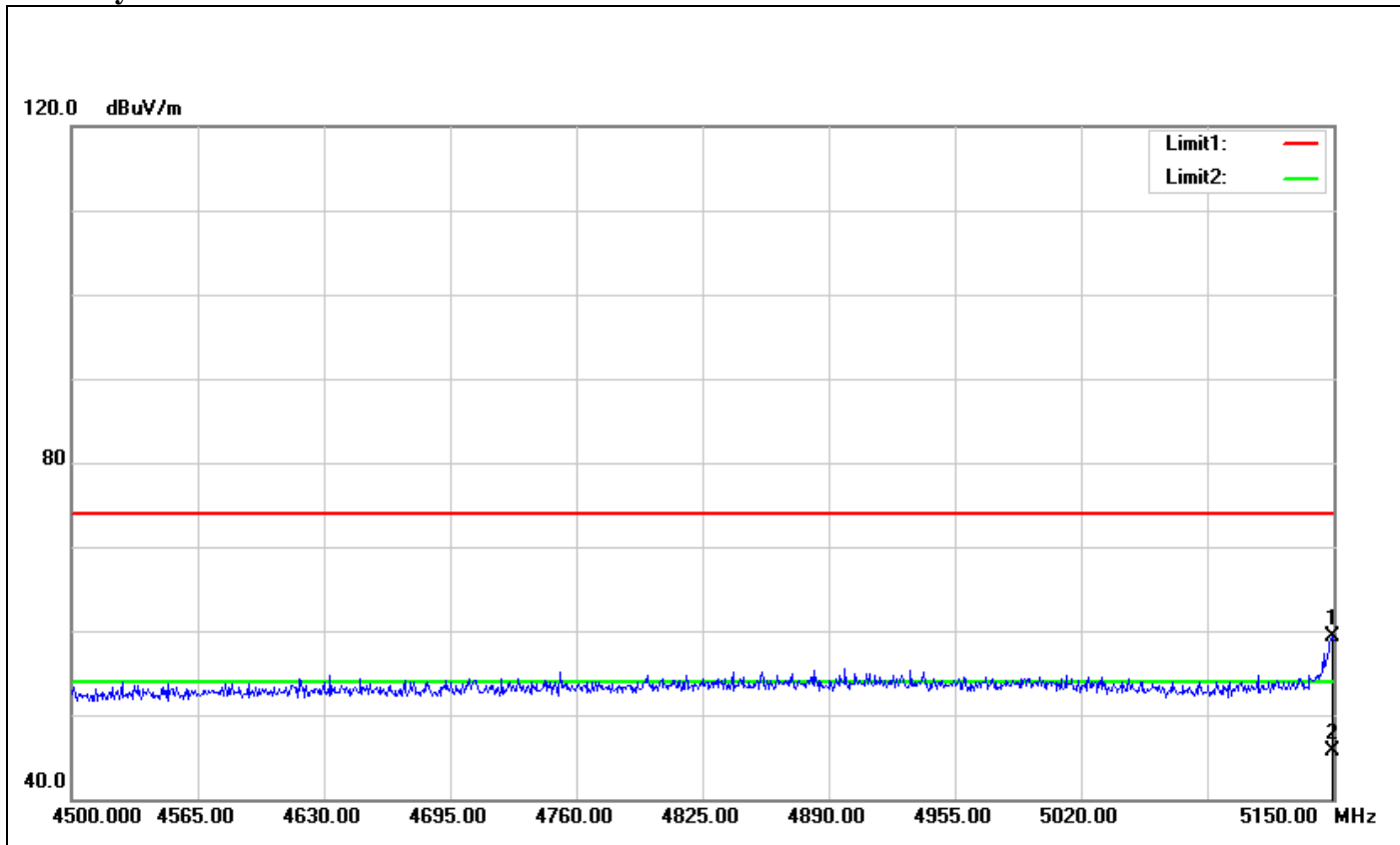

No.	Frequency	Reading	Correct	Result	Limit	Margin	Height	Degree	Remark
	(MHz)	(dBuV)	Factor(dB/m)	(dBuV/m)	(dBuV/m)	(dB)	(cm)	(°)	
1	5149.350	56.19	3.04	59.23	74.00	-14.77	100	230	peak
2	5149.350	42.61	3.04	45.65	54.00	-8.35	100	230	AVG



Band Edges (IEEE 802.11n HT 40 mode / 5190 MHz)

Polarity: Vertical

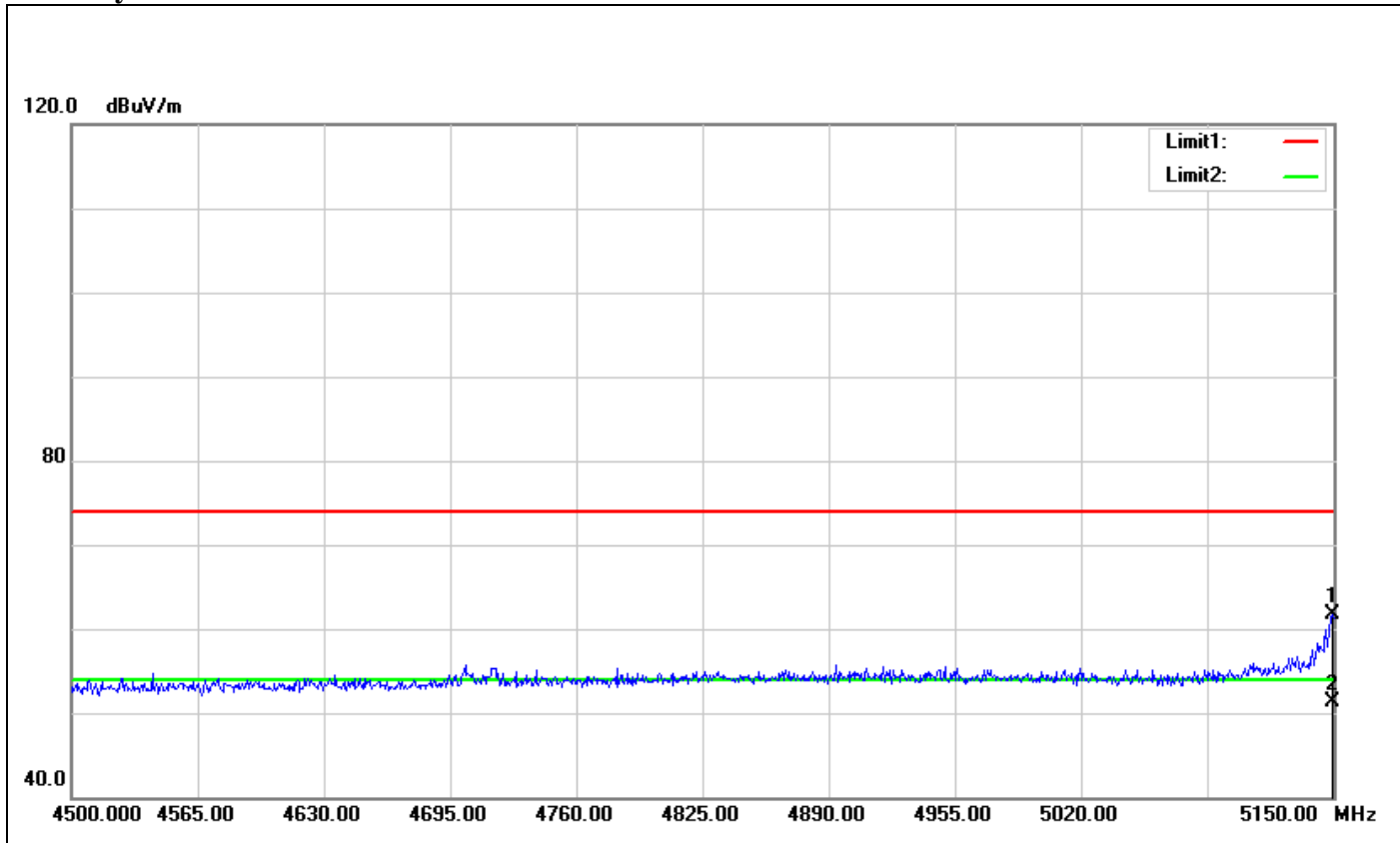

No.	Frequency	Reading	Correct	Result	Limit	Margin	Height	Degree	Remark
	(MHz)	(dBuV)	Factor(dB/m)	(dBuV/m)	(dBuV/m)	(dB)	(cm)	(°)	
1	5149.350	58.75	3.04	61.79	74.00	-12.21	100	106	peak
2	5149.350	48.19	3.04	51.23	54.00	-2.77	100	106	AVG



Polarity: Horizontal

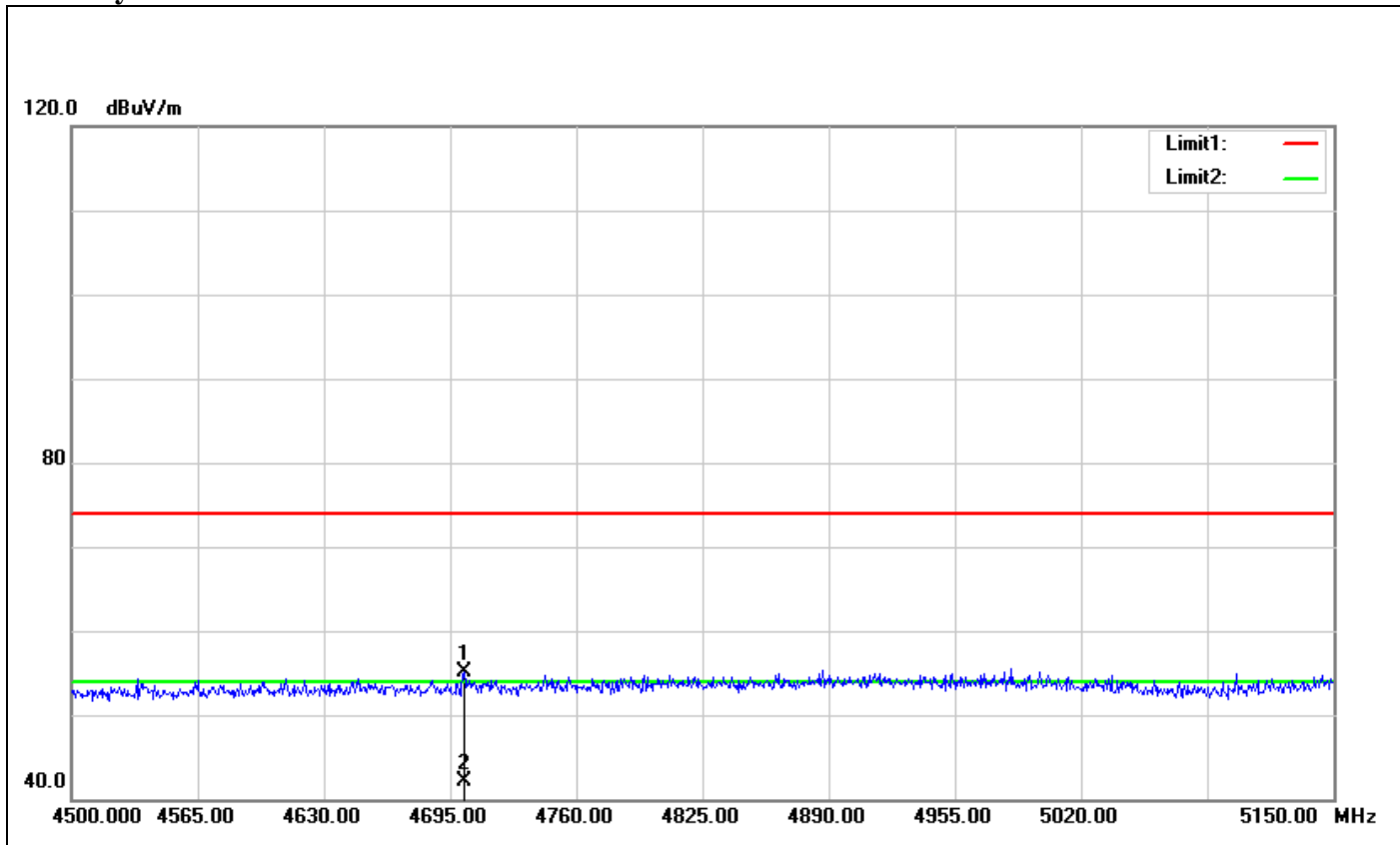

No.	Frequency	Reading	Correct	Result	Limit	Margin	Height	Degree	Remark
	(MHz)	(dBuV)	Factor(dB/m)	(dBuV/m)	(dBuV/m)	(dB)	(cm)	(°)	
1	4702.150	51.49	3.67	55.16	74.00	-18.84	100	112	peak
2	4702.150	38.46	3.67	42.13	54.00	-11.87	100	112	AVG



Band Edges (IEEE 802.11ac VHT80 Mode / CH 5210 MHz)

Polarity: Vertical

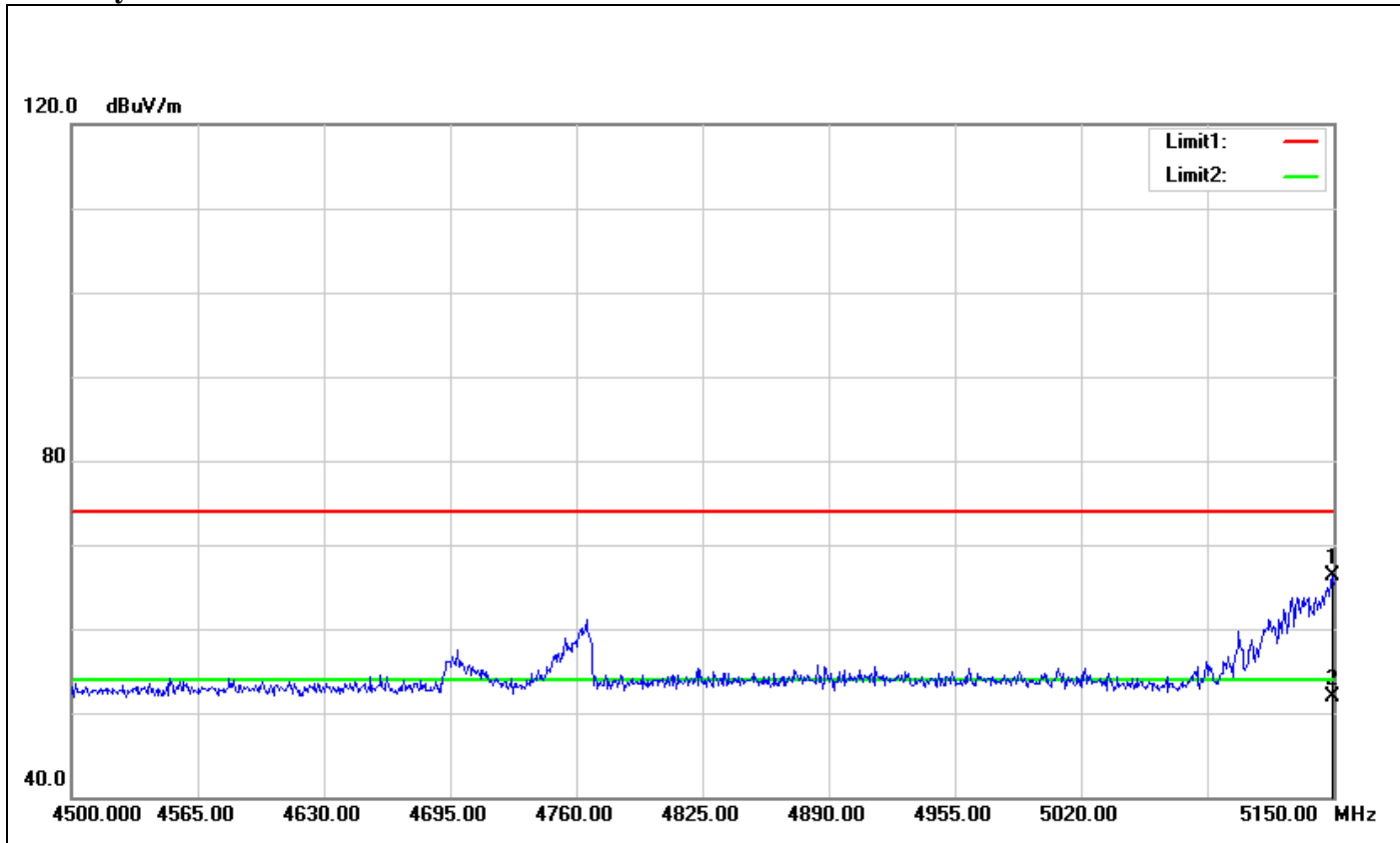

No.	Frequency (MHz)	Reading (dBuV)	Correct Factor(dB/m)	Result (dBuV/m)	Limit (dBuV/m)	Margin (dB)	Height (cm)	Degree (°)	Remark
1	5149.350	63.26	3.04	66.30	74.00	-7.70	100	350	peak
2	5149.350	48.89	3.04	51.93	54.00	-2.07	100	350	AVG



Polarity: Horizontal

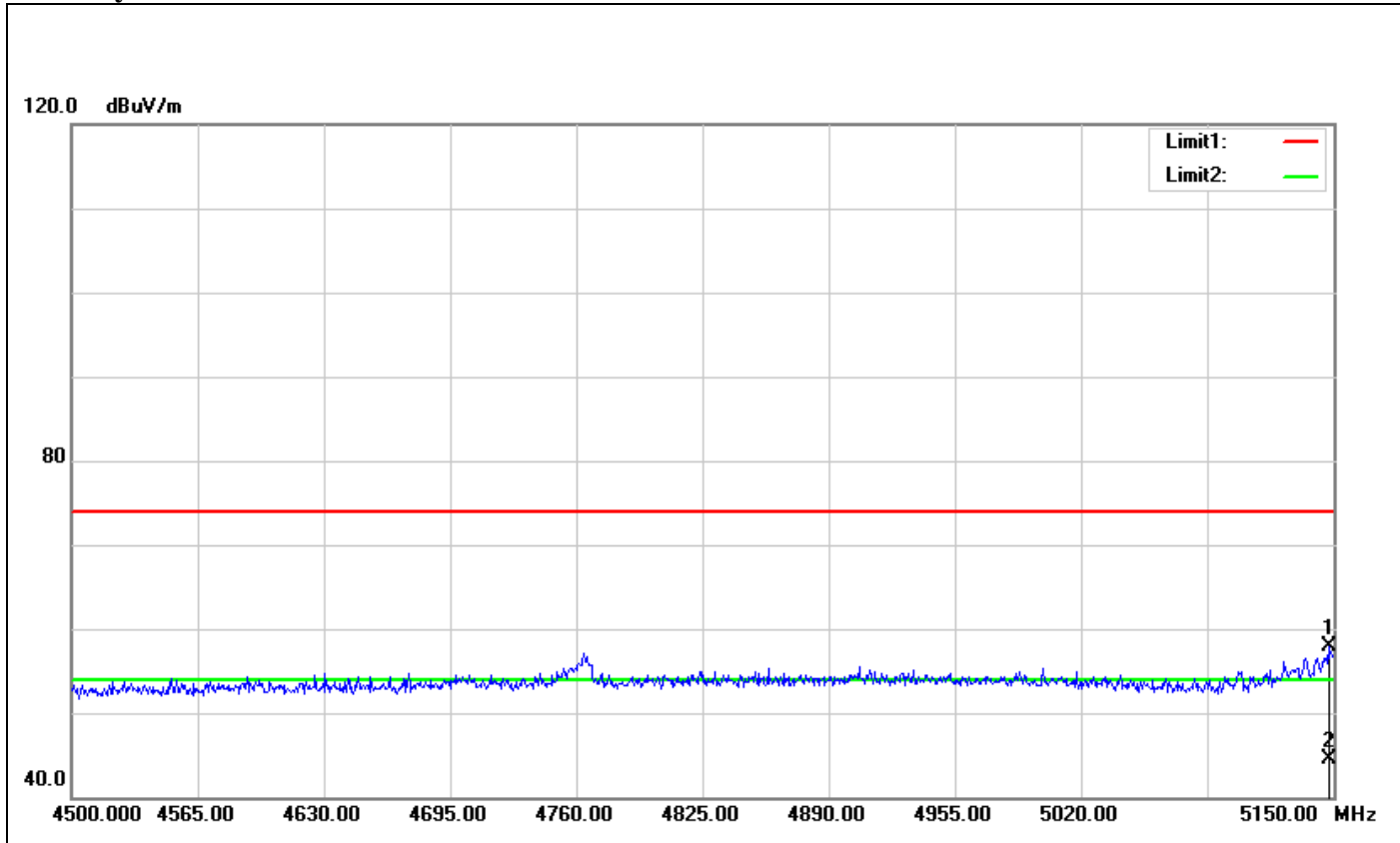

No.	Frequency	Reading	Correct	Result	Limit	Margin	Height	Degree	Remark
	(MHz)	(dBuV)	Factor(dB/m)	(dBuV/m)	(dBuV/m)	(dB)	(cm)	(°)	
1	5147.400	54.81	3.02	57.83	74.00	-16.17	100	83	peak
2	5147.400	41.51	3.02	44.53	54.00	-9.47	100	83	AVG



7.4 PEAK POWER SPECTRAL DENSITY

LIMIT

According to §15.407(a),

- (1) For the band 5.15-5.25 GHz, the peak power spectral density shall not exceed 4dBm in any 1MHz band.
- (2) For the band 5.25-5.35 GHz and 5.47-5.725 GHz bands, the peak power spectral density shall not exceed 11dBm in any 1MHz band.

If transmitting antennas of directional gain greater than 6dBi are used, both the peak transmit power and the peak power spectral density shall be reduced by the amount in dB that the directional gain of the antenna exceeds 6dBi.

Test Configuration

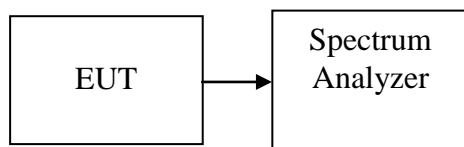

TEST PROCEDURE

1. Place the EUT on the table and set it in transmitting mode.
Remove the antenna from the EUT and then connect a low loss RF cable from the antenna port to the spectrum analyzer.
2. Set the spectrum analyzer as RBW = 1MHz, VBW = 3MHz, Span = Sweep= AUTO
3. Record the max. reading.
4. Repeat the above procedure until the measurements for all frequencies are completed

TEST RESULTS

No non-compliance noted



Test Data

Test mode: IEEE 802.11a mode / 5180 ~ 5240MHz

Channel	Frequency (MHz)	PPSD (dBm)	Limit (dBm)	Margin	Result
Low	5180	9.83	4.00	5.83	PASS
Mid	5220	9.78	4.00	5.78	PASS
High	5240	9.78	4.00	5.78	PASS

Test mode: IEEE 802.11n HT 20 mode / 5180 ~ 5240MHz

Channel	Frequency (MHz)	Chain 0 PPSD (dBm)	Chain 1 PPSD (dBm)	PPSD (dBm)	Limit (dBm)	Margin	Result
Low	5180	9.00	8.20	11.63	3.00	8.63	PASS
Mid	5220	8.91	8.16	11.56	3.00	8.56	PASS
High	5240	9.30	8.46	11.91	3.00	8.91	PASS

Test mode: IEEE 802.11n HT 40 mode / 5190 ~ 5230MHz

Channel	Frequency (MHz)	Chain 0 PPSD (dBm)	Chain 1 PPSD (dBm)	PPSD (dBm)	Limit (dBm)	Margin	Result
Low	5190	5.56	4.88	8.24	3.00	5.24	PASS
High	5230	6.36	5.99	9.19	3.00	6.19	PASS

Test mode: IEEE 802.11ac VHT80 Mode / 5210MHz

Channel	Frequency (MHz)	Chain 0 PPSD (dBm)	Chain 1 PPSD (dBm)	PPSD (dBm)	Limit (dBm)	Margin	Result
Mid	5210	1.08	-2.09	2.79	3.00	-0.21	PASS

Remark:

1. Total PPSD (dBm) = $10 * \text{LOG}(10^{(\text{Chain 0 PPSD} / 10)} + 10^{(\text{Chain 1 PPSD} / 10)})$
2. The maximum antenna gain is 7.09dBi; therefore the reduction due to antenna gain is 1dB, so the limit is 3dBm.



Test mode: IEEE 802.11a mode/ 5745 ~ 5825MHz

Channel	Frequency (MHz)	PPSD (dBm)	Limit (dBm)	Margin	Result
Low	5745	8.22	11.00	-2.78	PASS
Mid	5785	6.88	11.00	-4.12	PASS
High	5825	6.24	11.00	-4.76	PASS

Test mode: IEEE 802.11n HT 20 mode / 5745 ~ 5825MHz

Channel	Frequency (MHz)	Chain 0 PPSD (dBm)	Chain 1 PPSD (dBm)	PPSD (dBm)	Limit (dBm)	Margin	Result
Low	5745	5.53	6.70	9.16	10.00	-0.84	PASS
Mid	5785	5.26	4.47	7.89	10.00	-2.11	PASS
High	5825	7.02	7.43	10.24	10.00	0.24	PASS

Test mode: IEEE 802.11n HT 40 mode / 5755 ~ 5795MHz

Channel	Frequency (MHz)	Chain 0 PPSD (dBm)	Chain 1 PPSD (dBm)	PPSD (dBm)	Limit (dBm)	Margin	Result
Low	5755	4.14	3.78	6.97	10.00	-3.03	PASS
High	5795	3.74	3.64	6.7	10.00	-3.3	PASS

Test mode: IEEE 802.11ac VHT80 Mode / 5775MHz

Channel	Frequency (MHz)	Chain 0 PPSD (dBm)	Chain 1 PPSD (dBm)	PPSD (dBm)	Limit (dBm)	Margin	Result
Mid	5775	-1.82	-2.62	0.81	3.00	-2.19	PASS

Remark:

1. Total PPSD (dBm) = $10 * \text{LOG}(10^{\text{Chain 0 PPSD} / 10} + 10^{\text{Chain 1 PPSD} / 10})$

2. The maximum antenna gain is 7.09dBi; therefore the reduction due to antenna gain is 1dB, so the limit is 10dBm.



Test Plot
IEEE 802.11a mode / 5180 ~ 5240MHz

CH Low

Agilent

R T

Mkr1 5.180 90 GHz
9.83 dBm

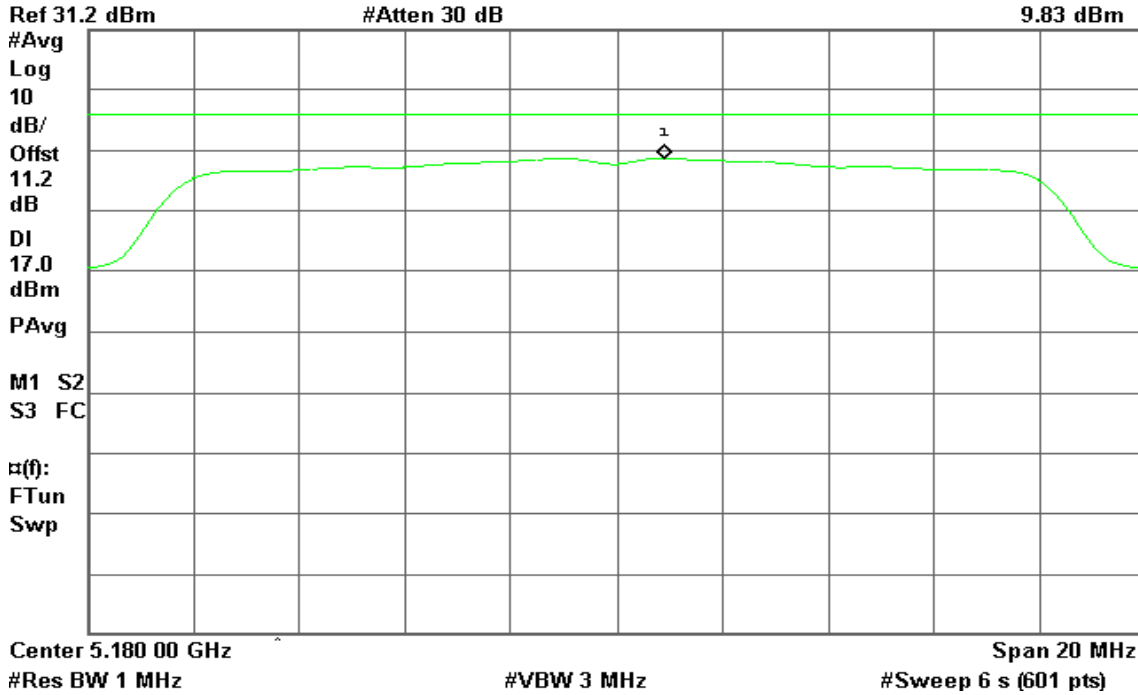

CH Mid

Agilent

R T

Mkr1 5.218 93 GHz
9.78 dBm

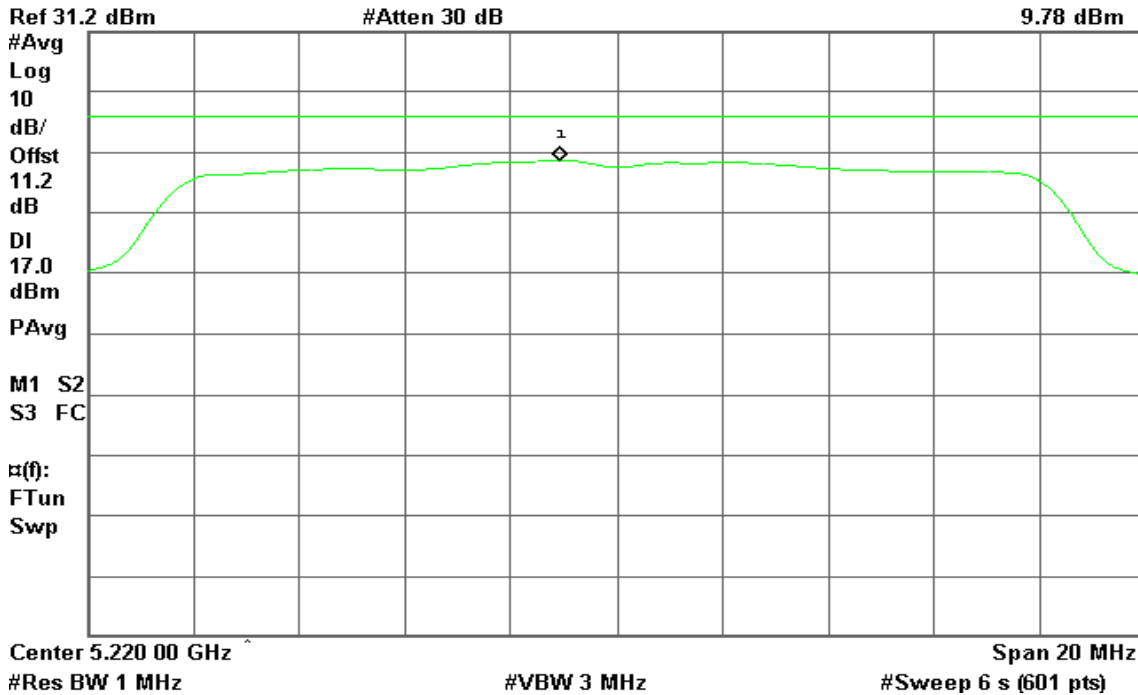



CH High

Agilent

R T

Mkr1 5.240 93 GHz

9.78 dBm

Ref 31.2 dBm

#Atten 30 dB

#Avg

Log

10

dB/

Offst

11.2

dB

DI

17.0

dBm

PAvg

M1 S2

S3 FC

$\alpha(f)$:

FTun

Swp

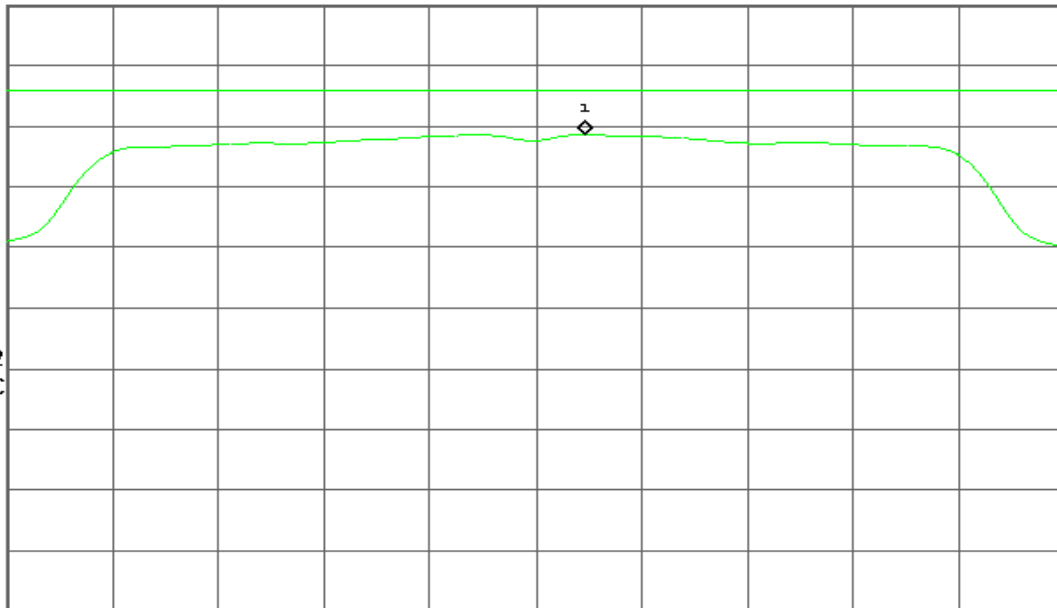

Center 5.240 00 GHz

Span 20 MHz

#Res BW 1 MHz

#VBW 3 MHz

#Sweep 6 s (601 pts)



IEEE 802.11n HT 20 mode / 5180 ~ 5240MHz / Chain 0

CH Low

Agilent

R T

Mkr1 5.178 80 GHz
9.00 dBm

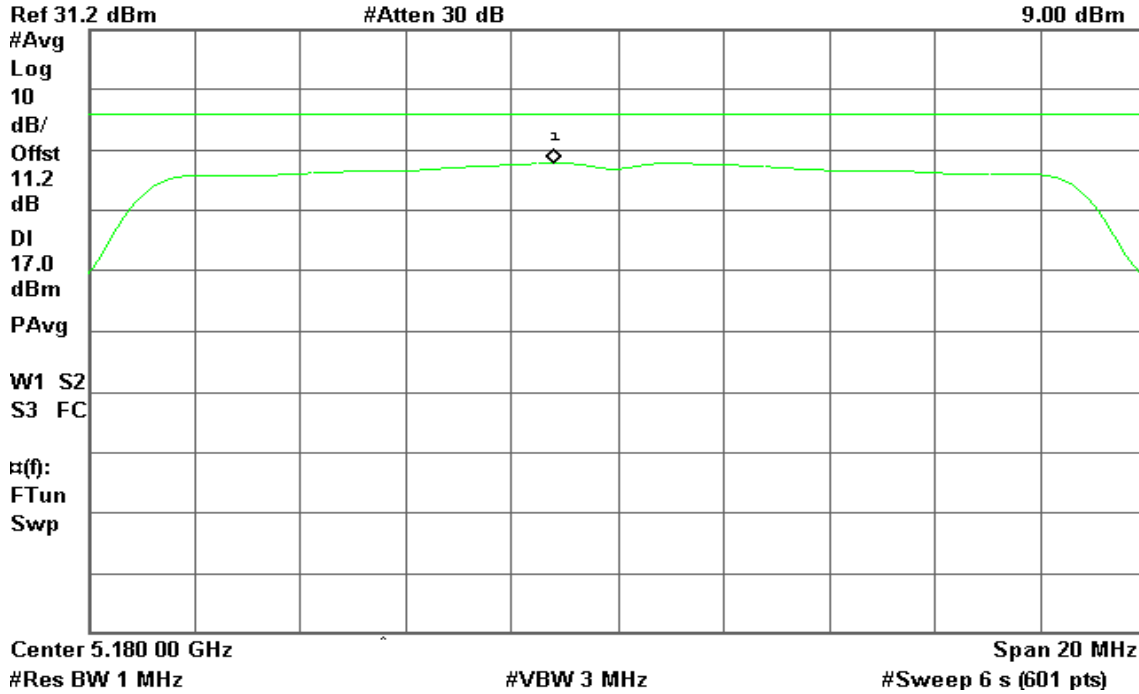

CH Mid

Agilent

R T

Mkr1 5.220 87 GHz
8.91 dBm

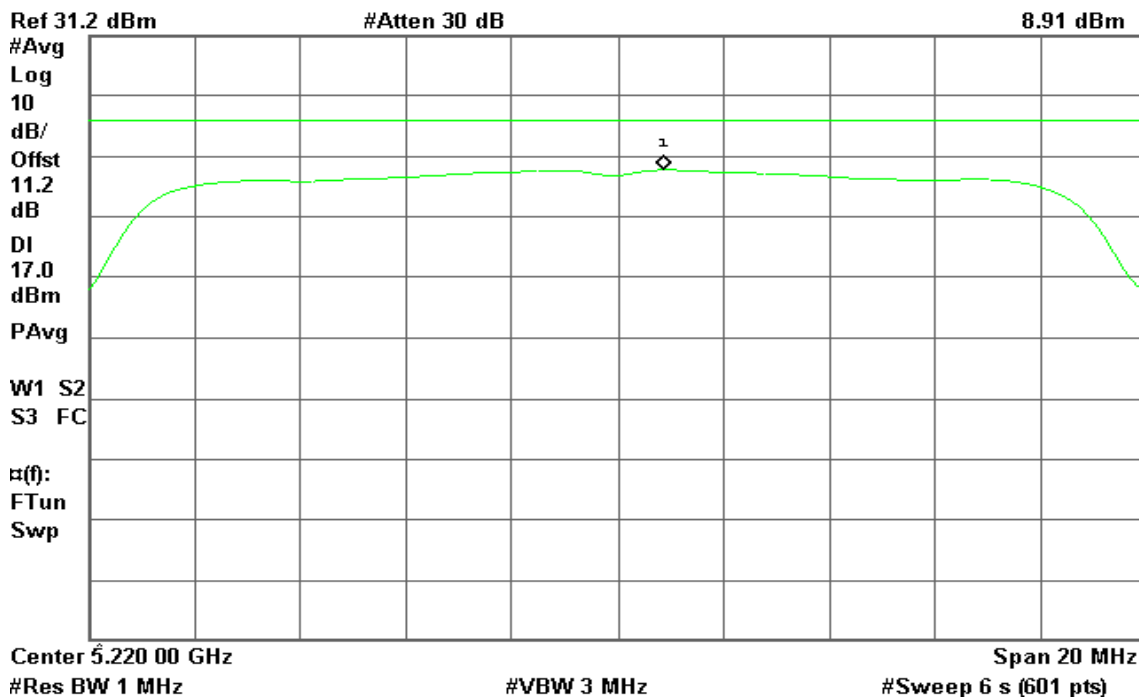



CH High

Agilent

R T

Mkr1 5.238 80 GHz

9.30 dBm

Ref 31.2 dBm

#Atten 30 dB

#Avg

Log

10

dB/

Offst

11.2

dB

DI

17.0

PAvg

W1 S2

S3 FC

$\alpha(f)$:

FTun

Swp

Center 5.240 00 GHz

#Res BW 1 MHz

#VBW 3 MHz

Span 20 MHz

#Sweep 6 s (601 pts)

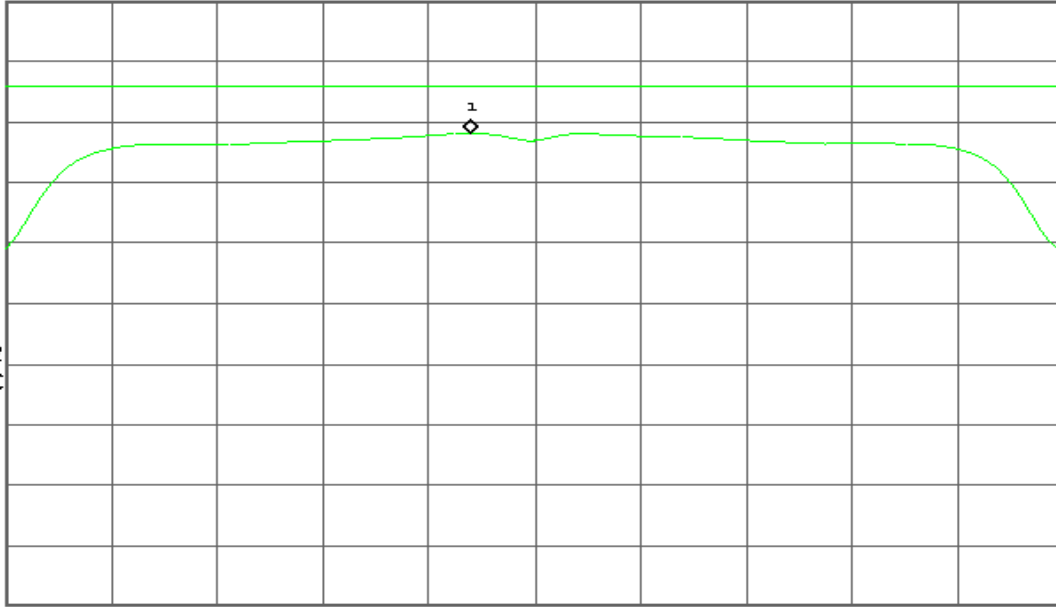



IEEE 802.11n HT 20 mode / 5180 ~ 5240MHz / Chain 1

CH Low

Agilent

R T

Mkr1 5.178 80 GHz
8.20 dBm

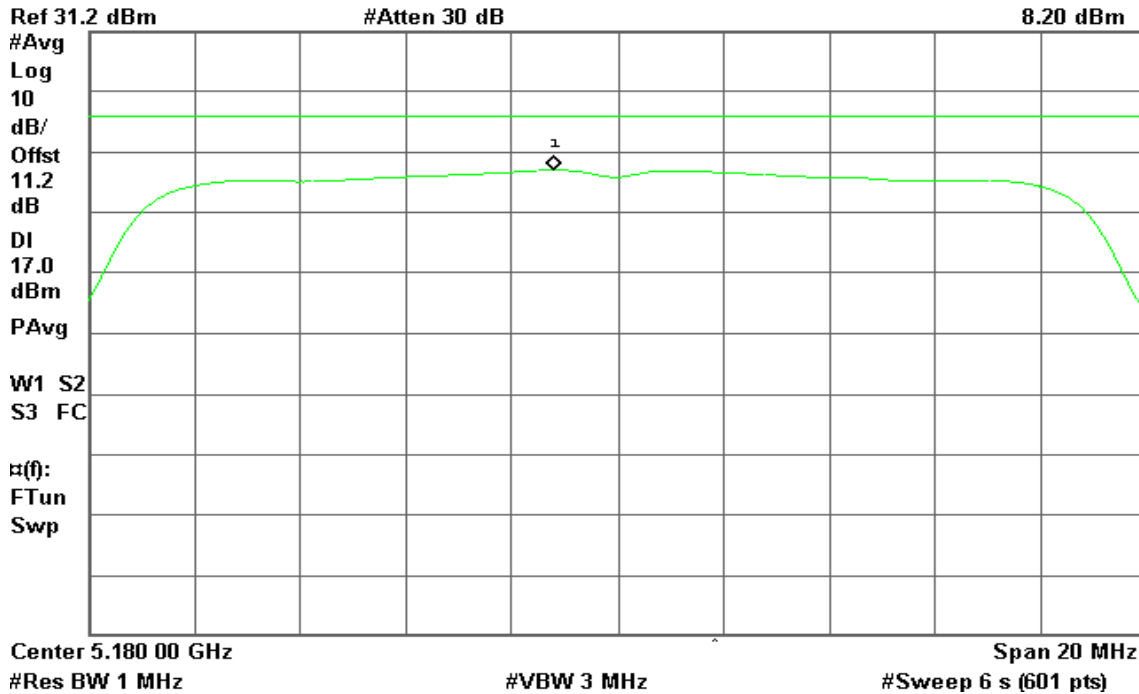

CH Mid

Agilent

R T

Mkr1 5.218 83 GHz
8.16 dBm

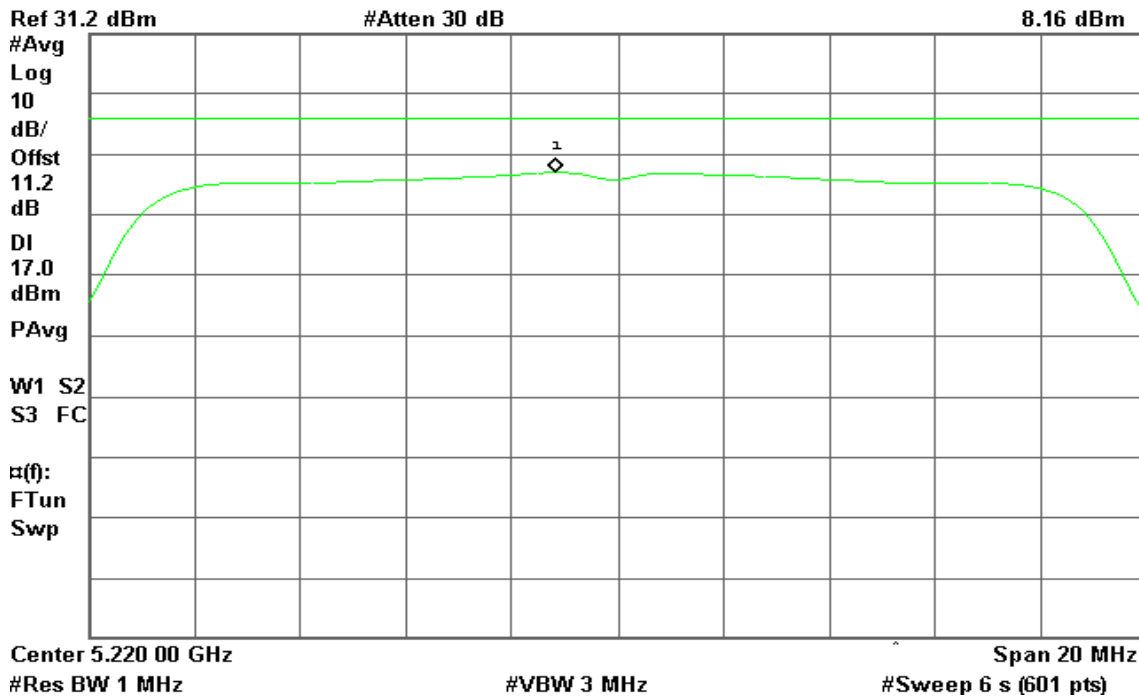



CH High

Agilent

R T

Mkr1 5.238 83 GHz

8.46 dBm

Ref 31.2 dBm

#Atten 30 dB

#Avg

Log

10

dB/

Offst

11.2

dB

DI

17.0

dBm

PAvg

W1 S2

S3 FC

$\alpha(f)$:

FTun

Swp

Center 5.240 00 GHz

#Res BW 1 MHz

#VBW 3 MHz

Span 20 MHz

#Sweep 6 s (601 pts)

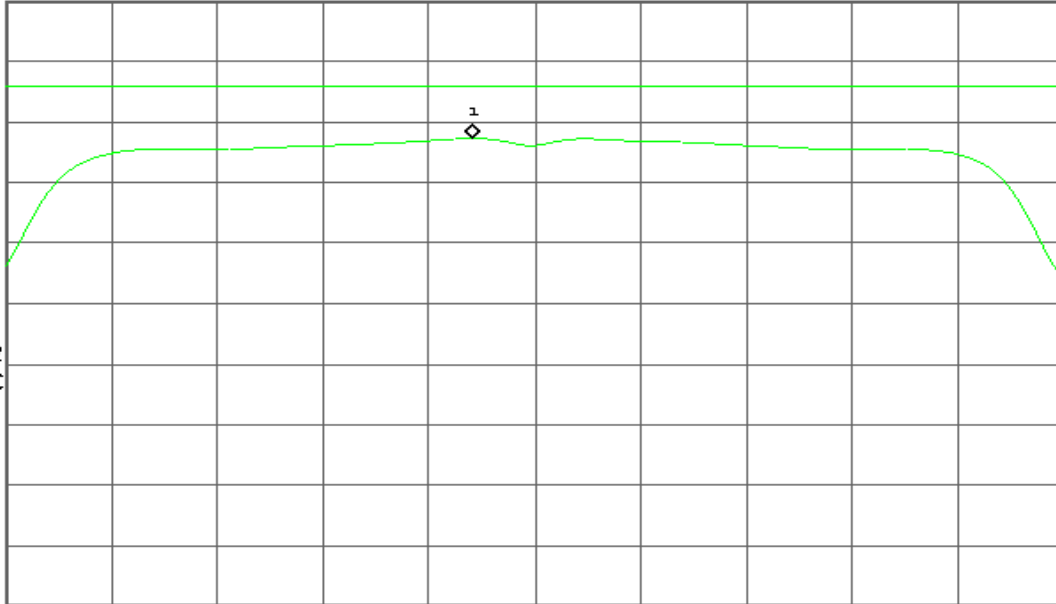



IEEE 802.11n HT 40 mode / 5190 ~ 5230MHz / Chain 0

CH Low

Agilent

R T

Mkr1 5.188 40 GHz
5.56 dBm

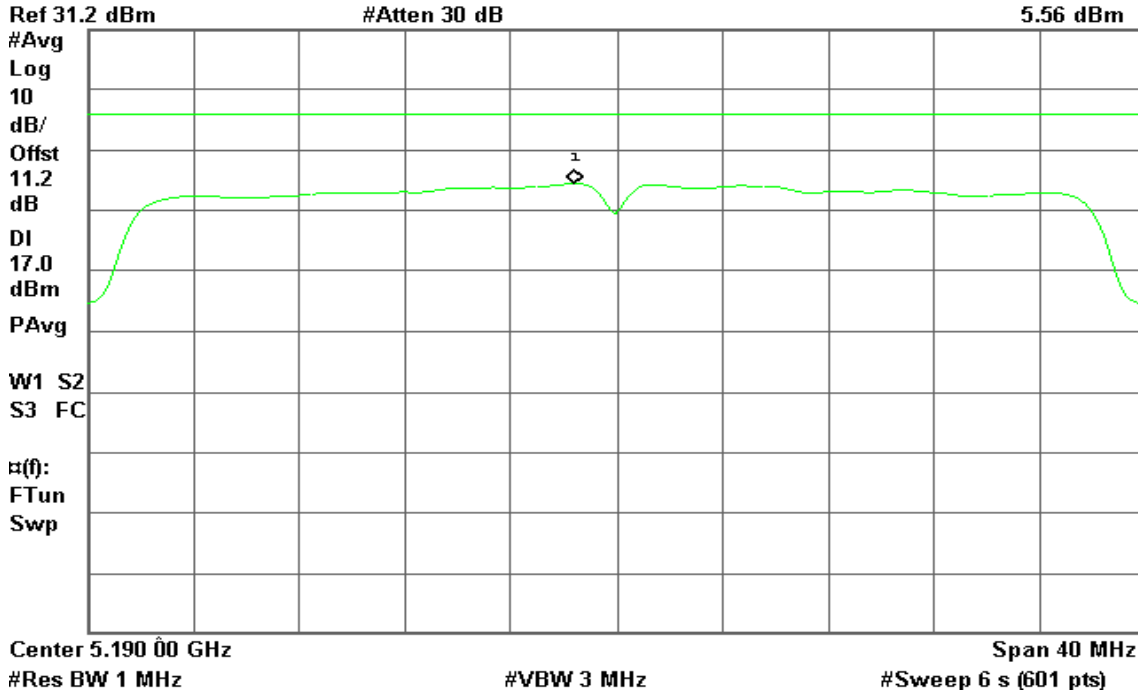

CH High

Agilent

R T

Mkr1 5.228 40 GHz
6.36 dBm

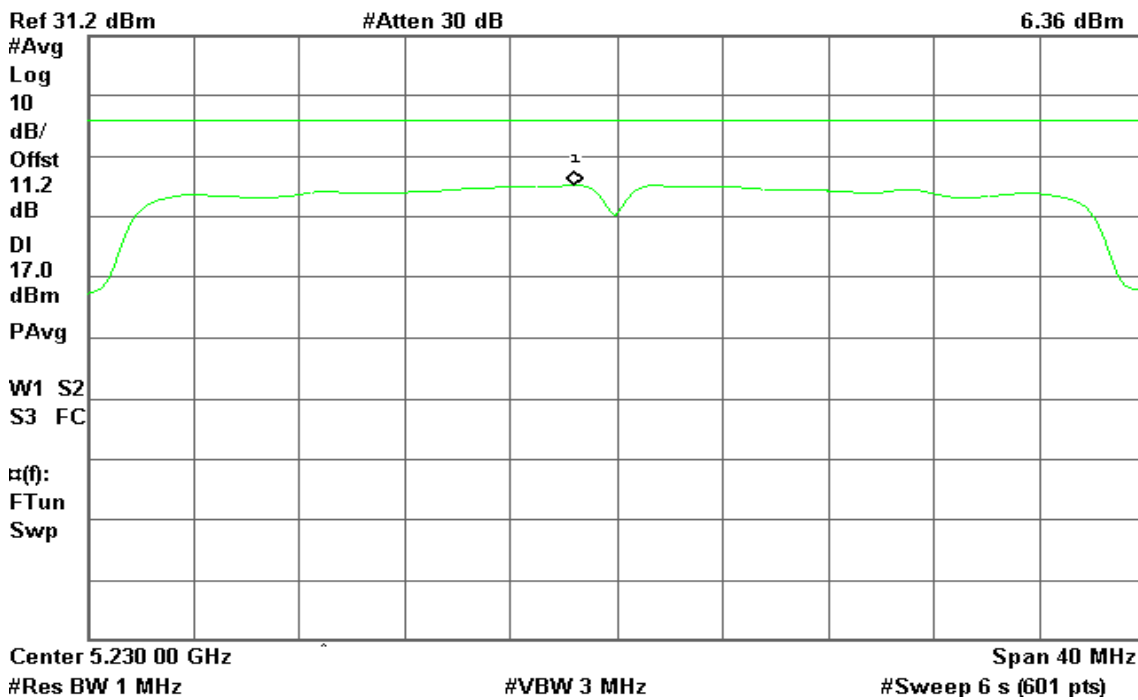



IEEE 802.11n HT 40 mode / 5190 ~ 5230MHz / Chain 1

CH Low

Agilent

R T

Mkr1 5.188 40 GHz
4.88 dBm

Ref 31.2 dBm

#Atten 30 dB

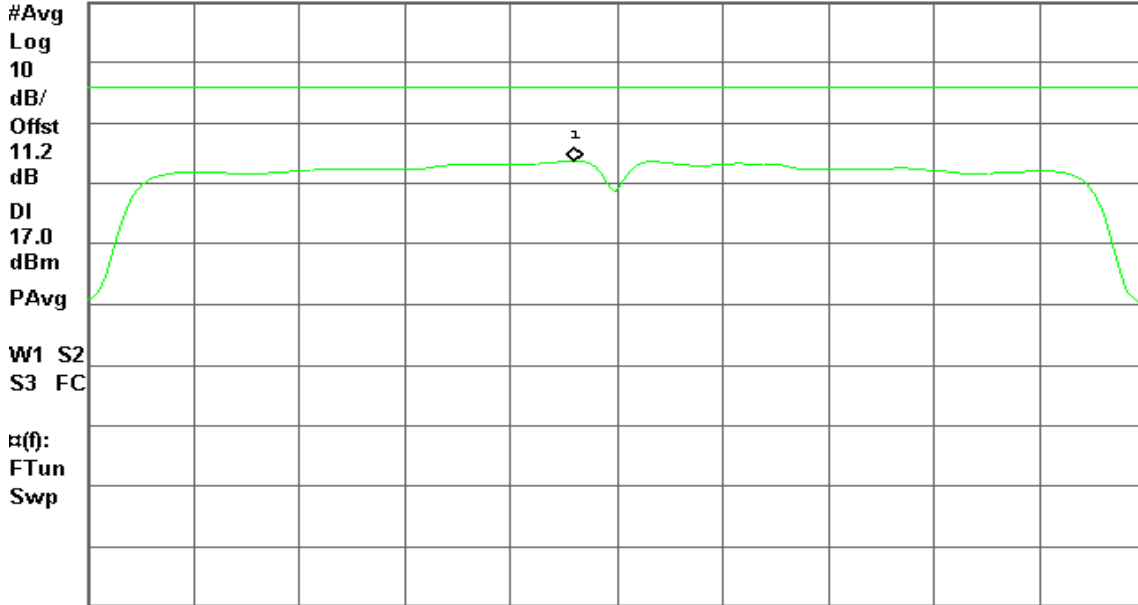

Center 5.190 00 GHz

#Res BW 1 MHz

#VBW 3 MHz

Span 40 MHz

#Sweep 6 s (601 pts)

CH High

Agilent

R T

Mkr1 5.228 40 GHz
5.99 dBm

Ref 31.2 dBm

#Atten 30 dB

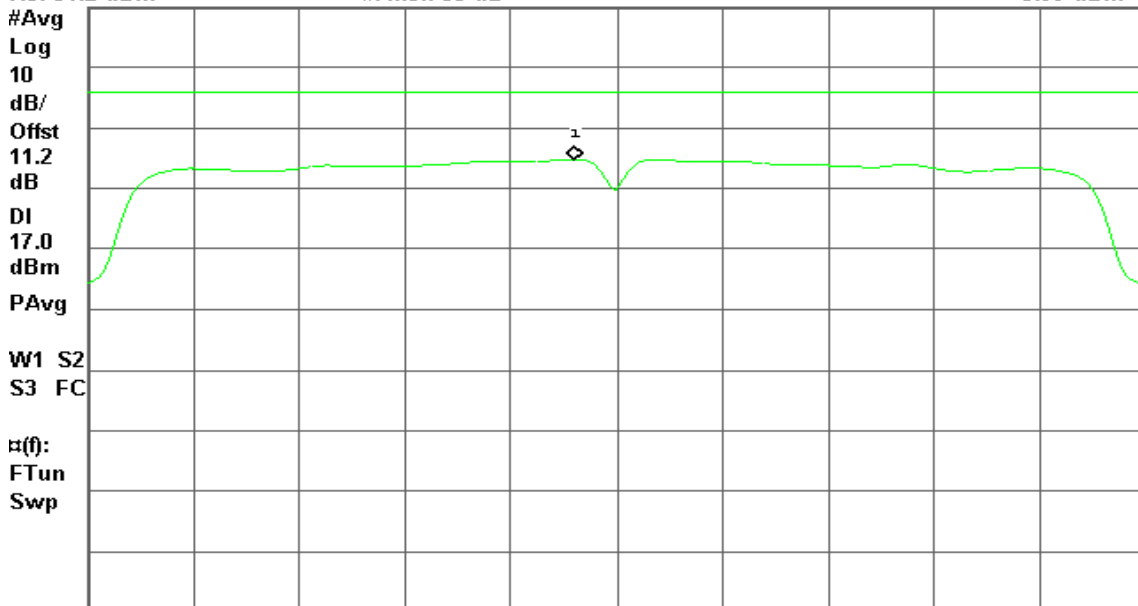

Center 5.230 00 GHz

#Res BW 1 MHz

#VBW 3 MHz

Span 40 MHz

#Sweep 6 s (601 pts)



IEEE 802.11ac VHT80 Mode / 5210MHz / Chain 0

CH Mid

Agilent

R T

Mkr1 5.206 40 GHz

1.08 dBm

Ref 31.2 dBm

#Atten 30 dB

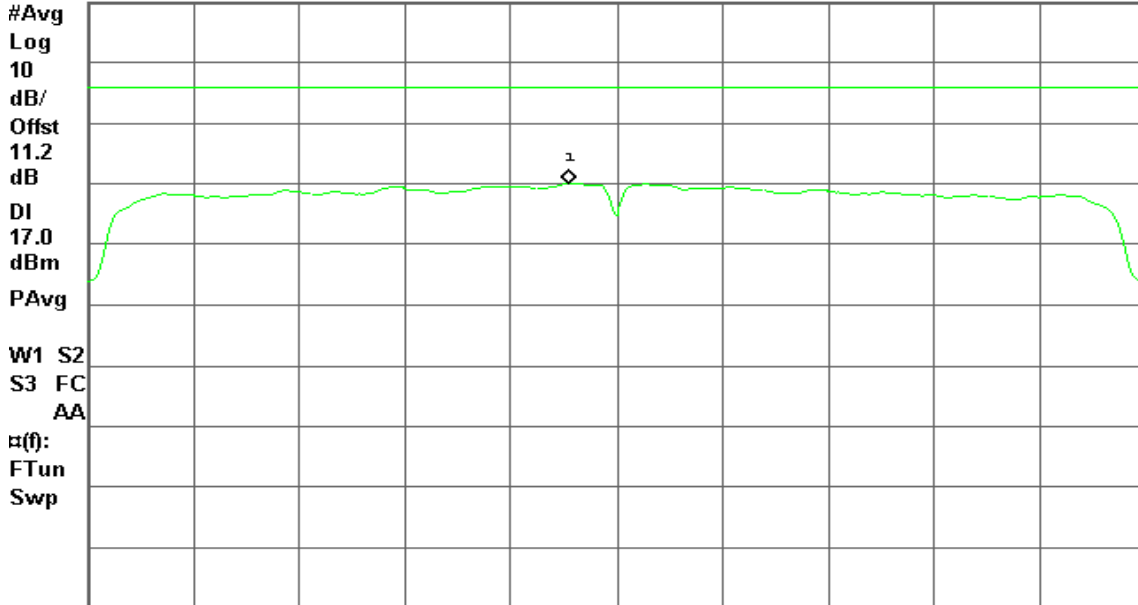

Center 5.210 00 GHz

Span 80 MHz

#Res BW 1 MHz

#VBW 3 MHz

#Sweep 6 s (601 pts)

IEEE 802.11ac VHT80 Mode / 5210MHz / Chain 1

CH Mid

Agilent

R T

Mkr1 5.207 07 GHz

-2.09 dBm

Ref 31.2 dBm

#Atten 30 dB

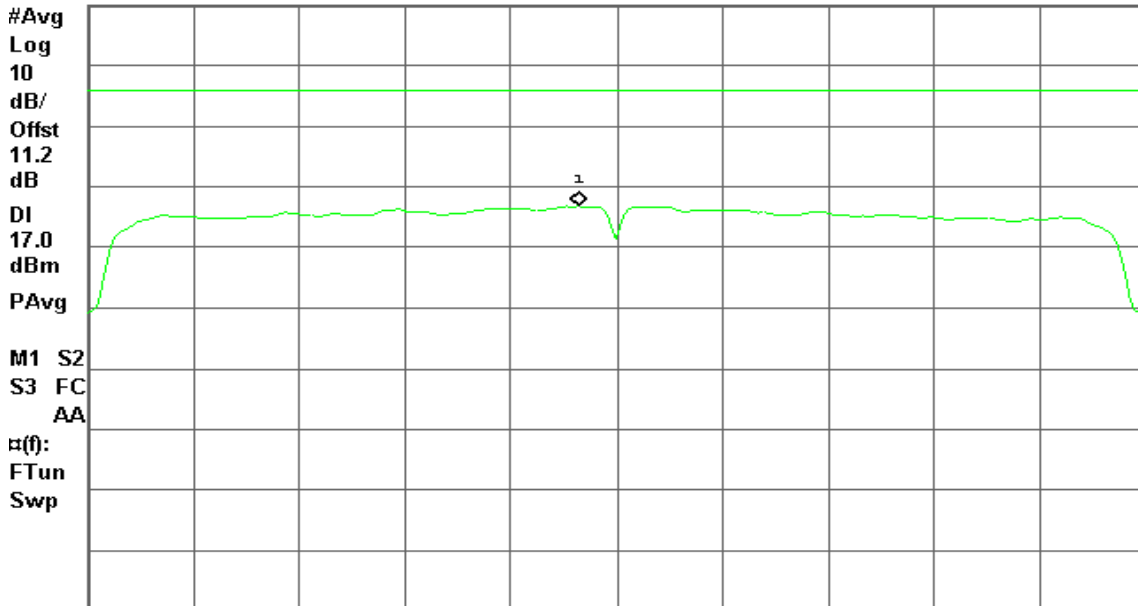

Center 5.210 00 GHz

Span 80 MHz

#Res BW 1 MHz

#VBW 3 MHz

#Sweep 6 s (601 pts)



IEEE 802.11a mode / 5745 ~ 5825MHz

CH Low

Agilent

R T

Mkr1 5.744 23 GHz

8.22 dBm

Ref 31.2 dBm

Atten 30 dB

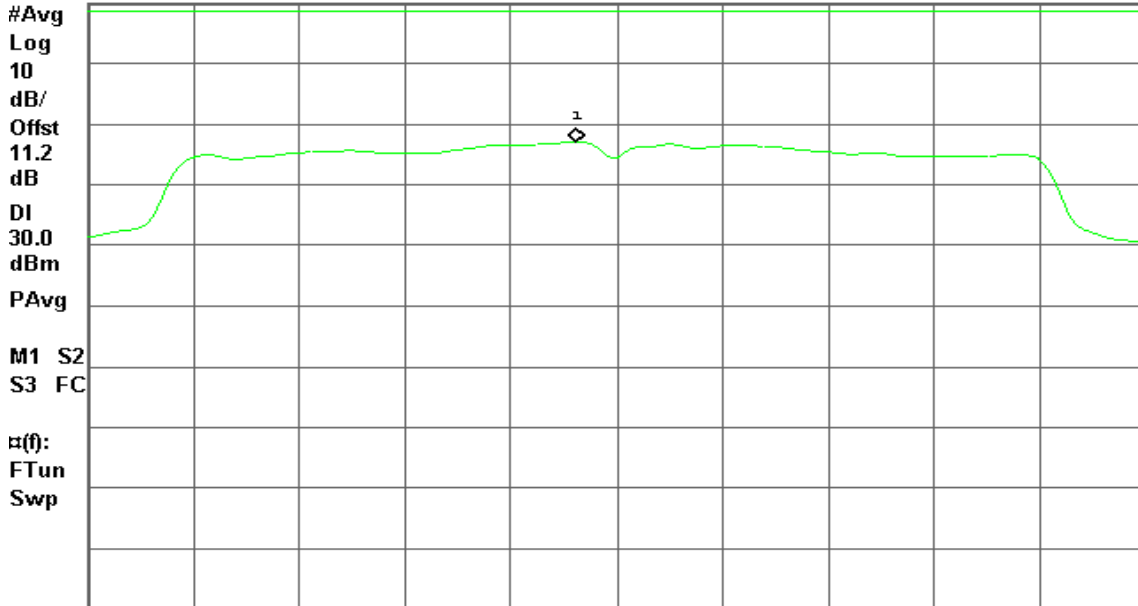

Center 5.745 00 GHz

#Res BW 510 kHz

#VBW 1.6 MHz

Span 20 MHz

#Sweep 6 s (601 pts)

CH Mid

Agilent

R T

Mkr1 5.784 30 GHz

6.88 dBm

Ref 31.2 dBm

Atten 30 dB

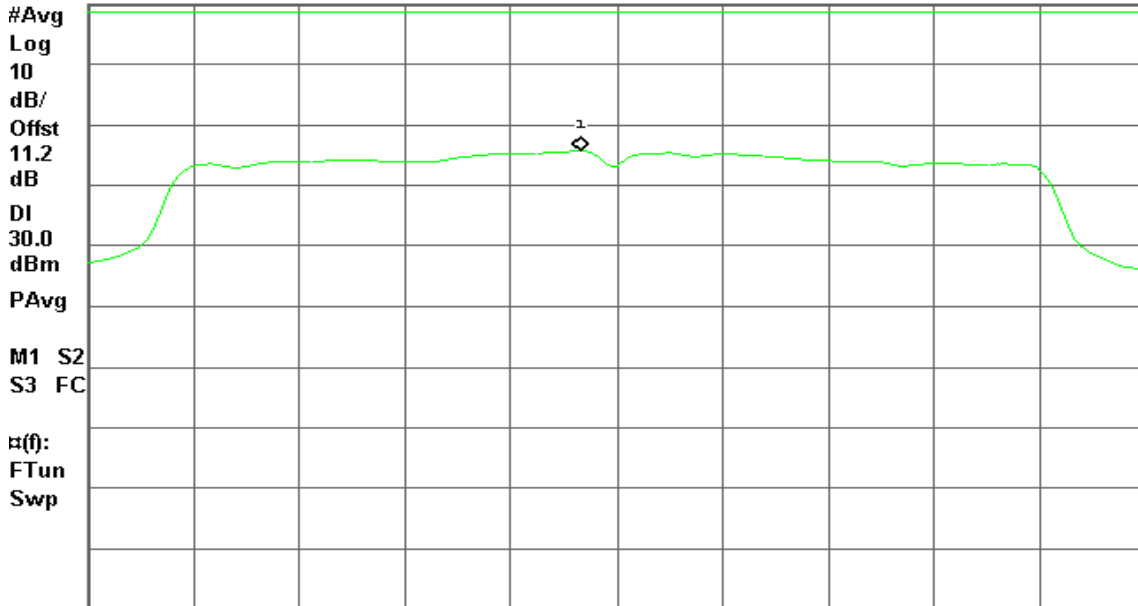

Center 5.785 00 GHz

#Res BW 510 kHz

#VBW 1.6 MHz

Span 20 MHz

#Sweep 6 s (601 pts)



CH High

Agilent

R T

Mkr1 5.825 57 GHz

6.24 dBm

Ref 31.2 dBm

Atten 30 dB

#Avg

Log

10

dB/

Offst

11.2

dB

DI

30.0

dBm

PAvg

M1 S2

S3 FC

$\alpha(f)$:

FTun

Swp



Center 5.825 00 GHz

#Res BW 510 kHz

#VBW 1.6 MHz

Span 20 MHz

#Sweep 6 s (601 pts)



IEEE 802.11n HT 20 mode / 5745 ~ 5825MHz / Chain 0

CH Low

Agilent

R T

Mkr1 5.745 60 GHz
5.53 dBm

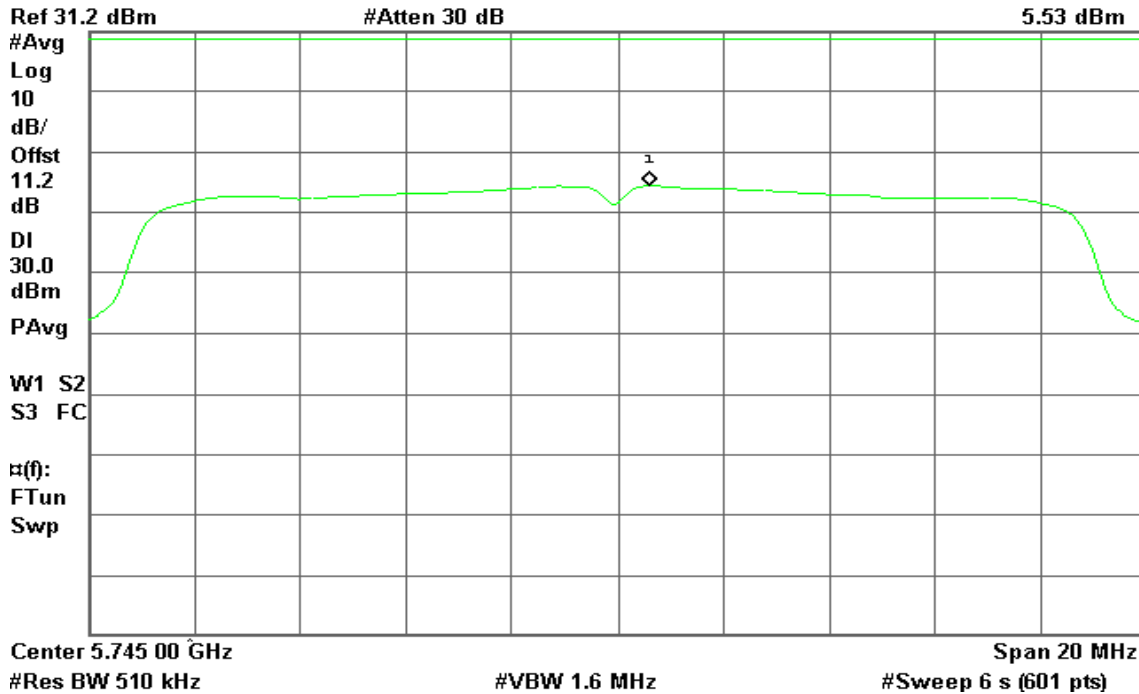

CH Mid

Agilent

R T

Mkr1 5.783 67 GHz
5.26 dBm

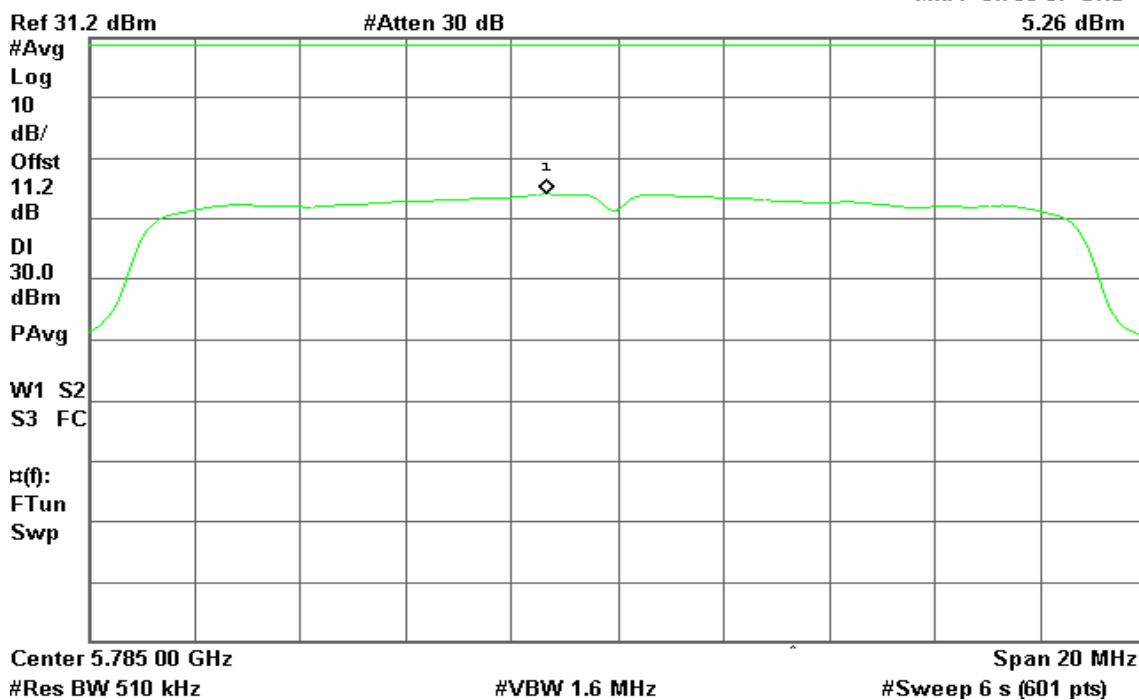



CH High

Agilent

R T

Mkr1 5.825 63 GHz

Ref 31.2 dBm

#Atten 30 dB

7.02 dBm

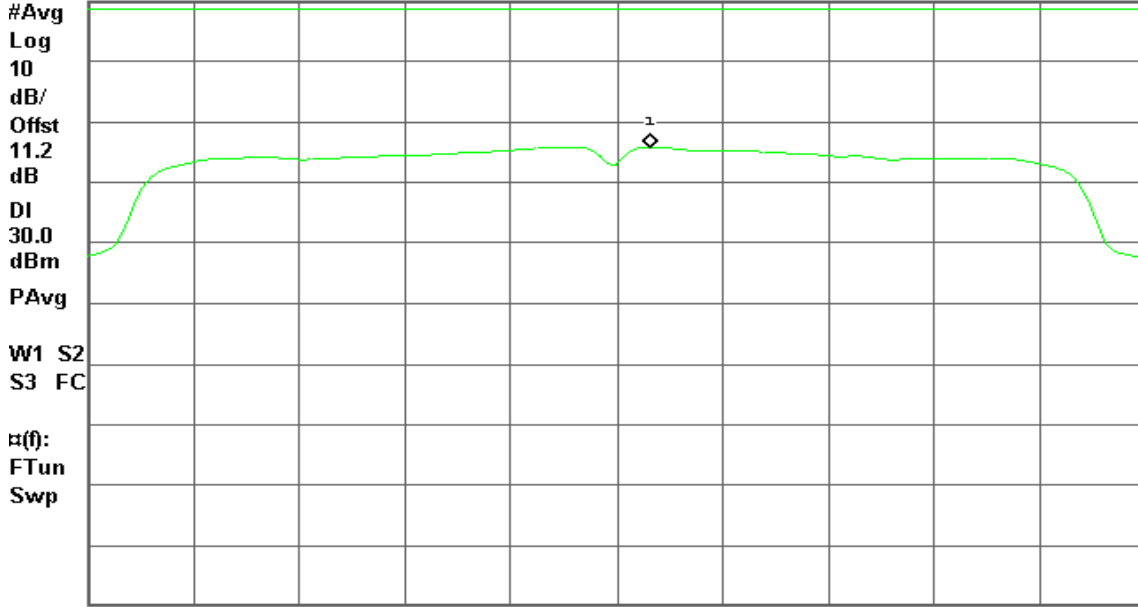

Center 5.825 00 GHz

Span 20 MHz

#Res BW 510 kHz

#VBW 1.6 MHz

#Sweep 6 s (601 pts)



IEEE 802.11n HT 20 mode / 5745 ~ 5825MHz / Chain 1

CH Low

Agilent

R T

Mkr1 5.743 63 GHz
6.70 dBm

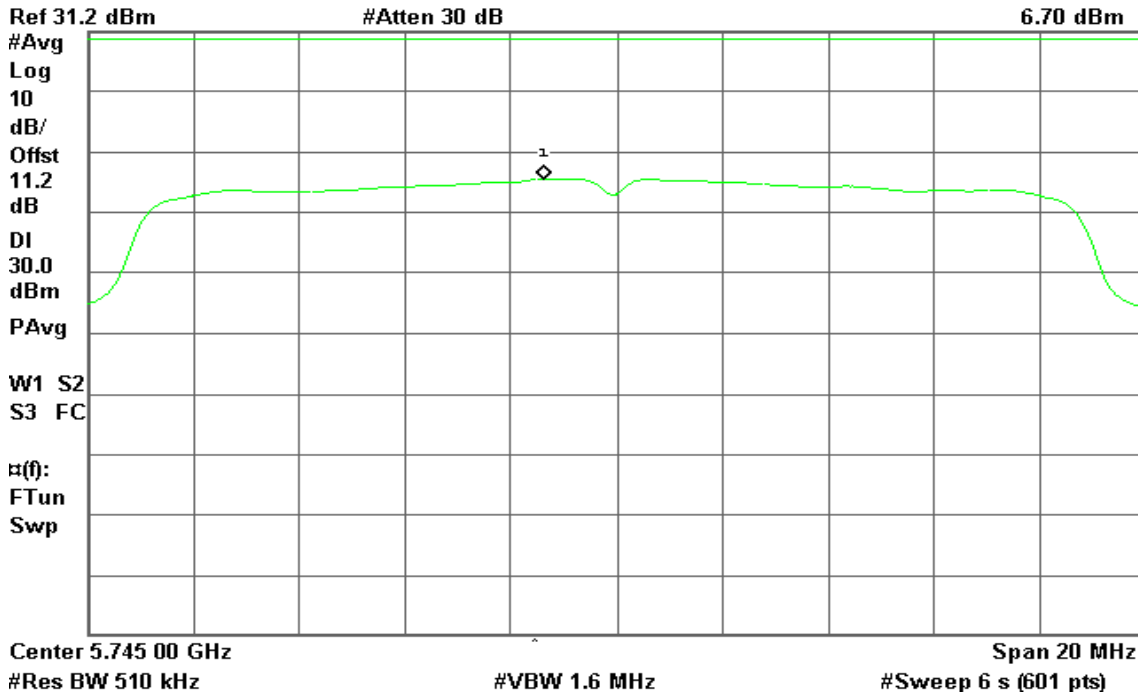

CH Mid

Agilent

R T

Mkr1 5.783 70 GHz
4.47 dBm

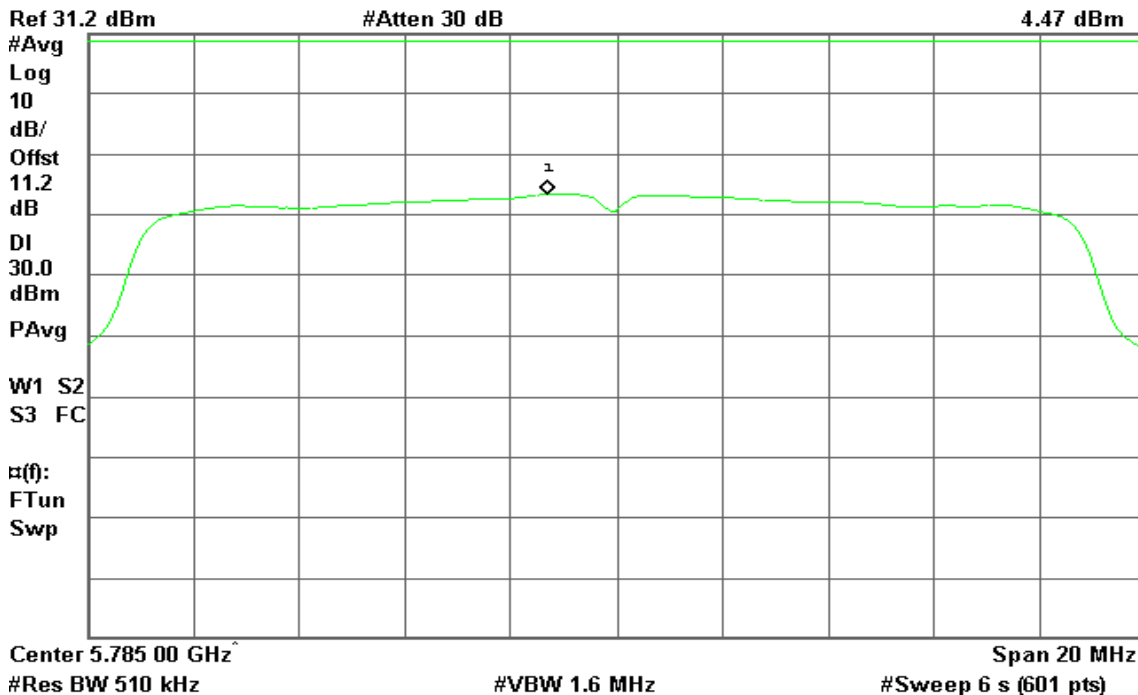



CH High

Agilent

R T

Mkr1 5.825 63 GHz

Ref 31.2 dBm

#Atten 30 dB

7.43 dBm

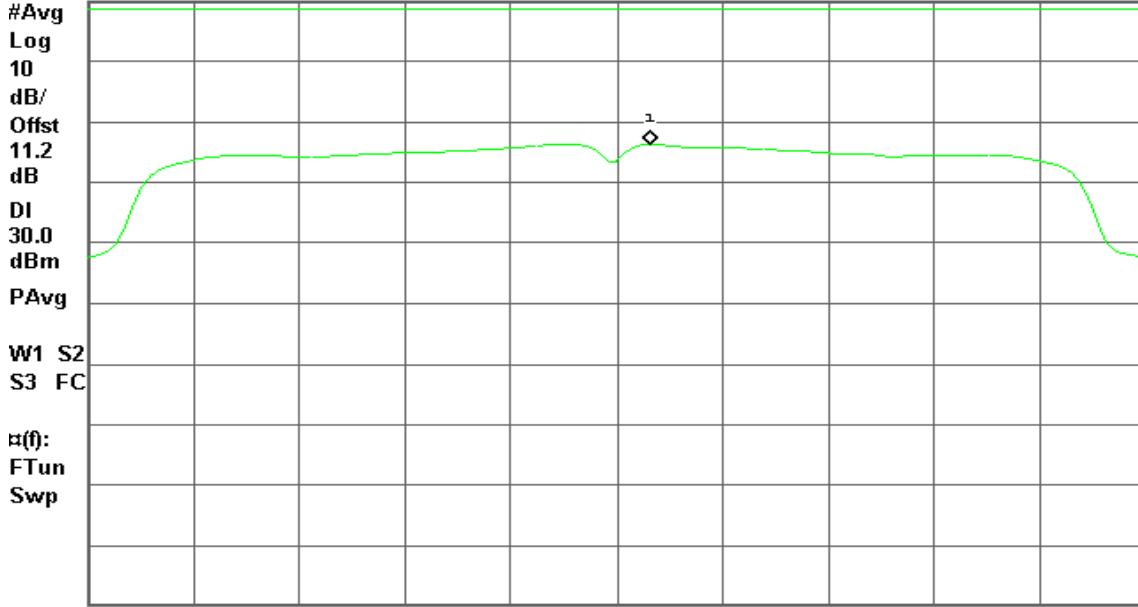

Center 5.825 00 GHz

Span 20 MHz

#Res BW 510 kHz

#VBW 1.6 MHz

#Sweep 6 s (601 pts)



IEEE 802.11n HT 40 mode / 5755 ~ 5795MHz / Chain 0

CH Low

Agilent

R T

Mkr1 5.756 07 GHz
4.14 dBm

Ref 31.2 dBm

#Atten 30 dB



Center 5.755 00 GHz

#Res BW 510 kHz

#VBW 1.6 MHz

Span 40 MHz

#Sweep 6 s (601 pts)

CH High

Agilent

R T

Mkr1 5.793 40 GHz
3.74 dBm

Ref 31.2 dBm

#Atten 30 dB

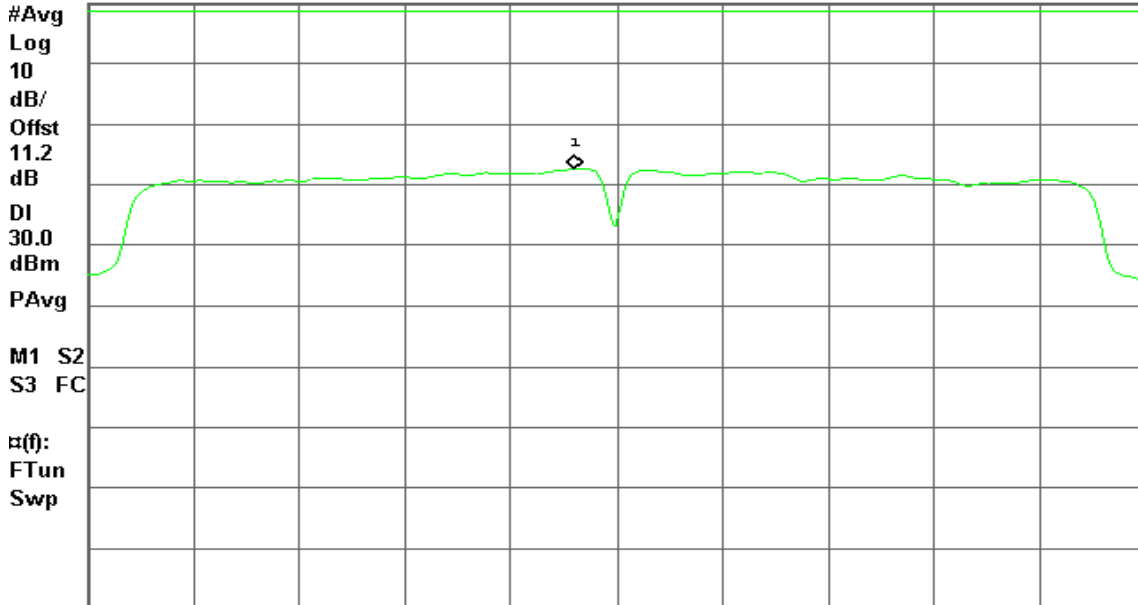

Center 5.795 00 GHz

#Res BW 510 kHz

#VBW 1.6 MHz

Span 40 MHz

#Sweep 6 s (601 pts)



IEEE 802.11n HT 40 mode / 5755 ~ 5795MHz / Chain 1

CH Low

Agilent

R T

Mkr1 5.753 93 GHz
3.78 dBm

Ref 31.2 dBm

#Atten 30 dB

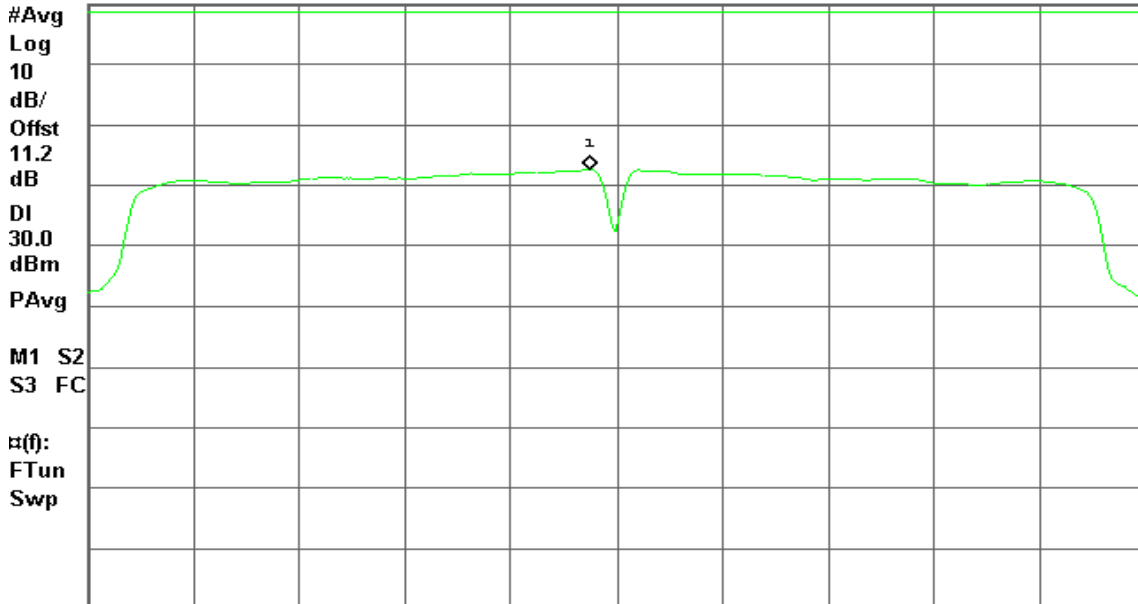

Center 5.755 00 GHz

#Res BW 510 kHz

#VBW 1.6 MHz

Span 40 MHz

#Sweep 6 s (601 pts)

CH High

Agilent

R T

Mkr1 5.793 33 GHz
3.64 dBm

Ref 31.2 dBm

#Atten 30 dB

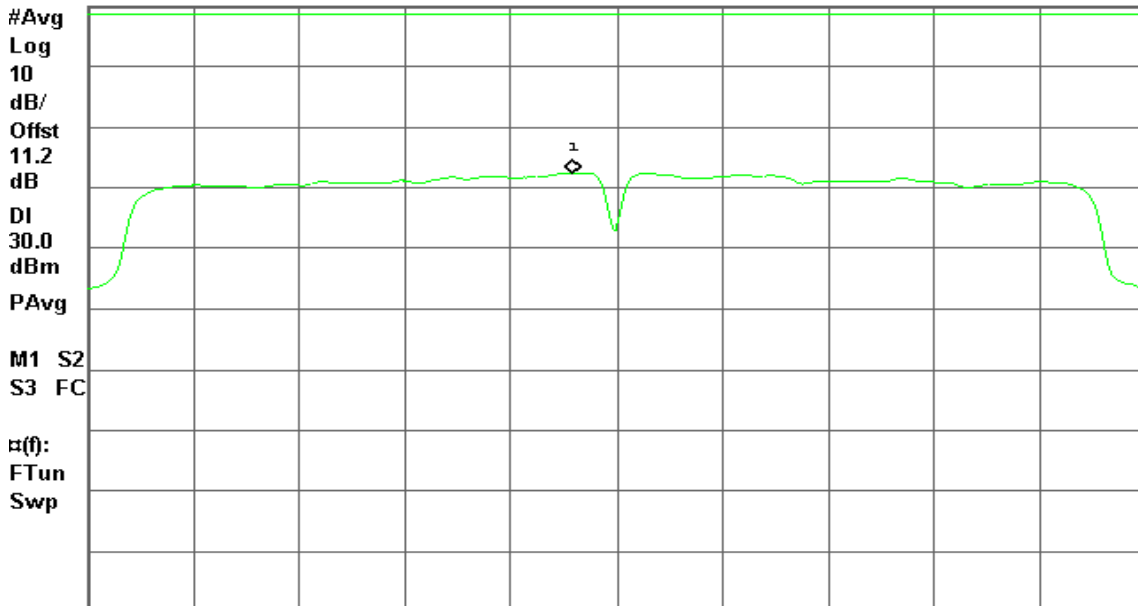

Center 5.795 00 GHz

#Res BW 510 kHz

#VBW 1.6 MHz

Span 40 MHz

#Sweep 6 s (601 pts)



IEEE 802.11ac VHT80 Mode / 5775MHz / Chain 0

CH Mid

Agilent

R T

Mkr1 5.738 37 GHz

-1.82 dBm

Ref 31.2 dBm

#Atten 30 dB

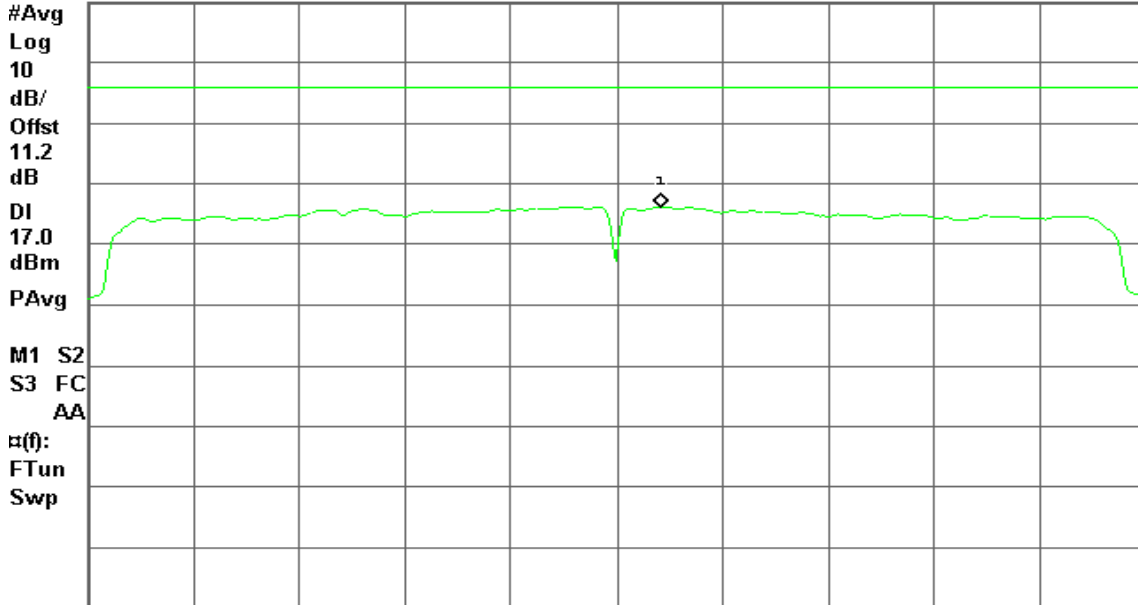

Center 5.775 00 GHz

#Res BW 510 kHz

#VBW 1.6 MHz

Span 80 MHz

#Sweep 6 s (601 pts)

IEEE 802.11ac VHT80 Mode / 5775MHz / Chain 1

CH Mid

Agilent

R T

Mkr1 5.778 33 GHz

-2.62 dBm

Ref 31.2 dBm

#Atten 30 dB

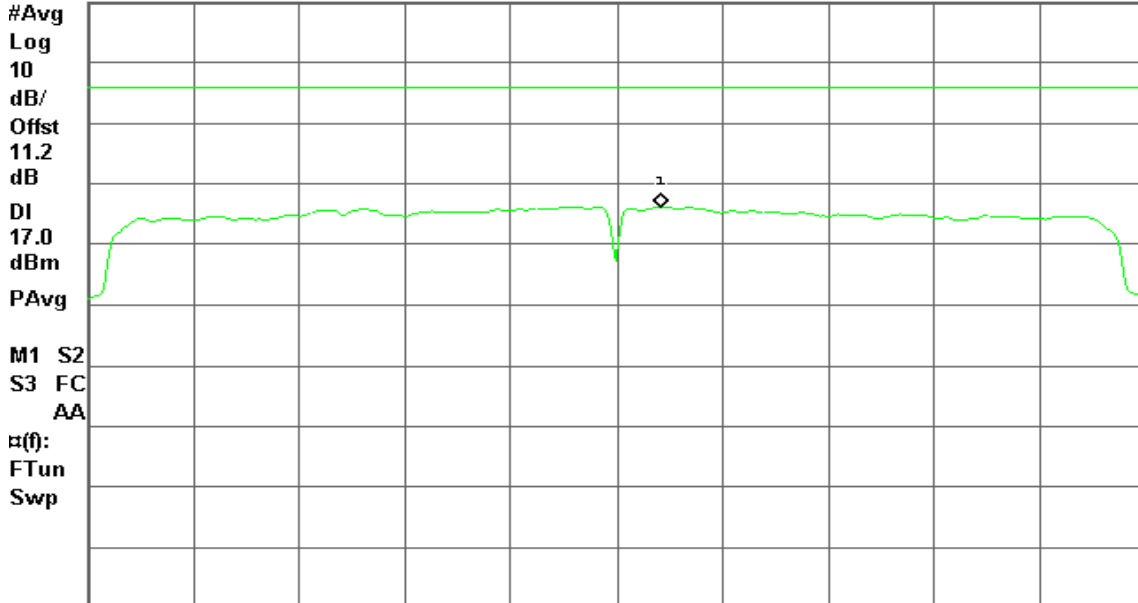

Center 5.775 00 GHz

#Res BW 510 kHz

#VBW 1.6 MHz

Span 80 MHz

#Sweep 6 s (601 pts)



7.5 RADIATED UNDESIRABLE EMISSION

1. According to §15.209(a), except as provided elsewhere in this Subpart, the emissions from an intentional radiator shall not exceed the field strength levels specified in the following table:

Frequency (MHz)	Field Strength (µV/m)	Measurement Distance (m)
0.009 - 0.490	2400/F(kHz)	300
0.490 - 1.705	24000/F(kHz)	30
1.705 – 30.0	30	30
30-88	100	3
88-216	150	3
216-960	200	3
Above 960	500	3

Remark: Except as provided in paragraph (g), fundamental emissions from intentional radiators operating under this Section shall not be located in the frequency bands 54-72 MHz, 76-88 MHz, 174-216 MHz or 470-806 MHz. However, operation within these frequency bands is permitted under other sections of this Part, e.g., Sections 15.231 and 15.241.

2. In the emission table above, the tighter limit applies at the band edges.

Frequency (MHz)	Field Strength (µV/m at 3-meter)	Field Strength (dBµV/m at 3-meter)
0.009 - 0.490	2400/F(kHz) +80	20LOG((2400/F(kHz))+80)
0.490 - 1.705	24000/F(kHz) +40	20LOG((24000/F(kHz))+40)
1.705 – 30.0	30	69.54
30-88	100	40
88-216	150	43.5
216-960	200	46
Above 960	500	54



Test Configuration

9kHz ~ 30MHz

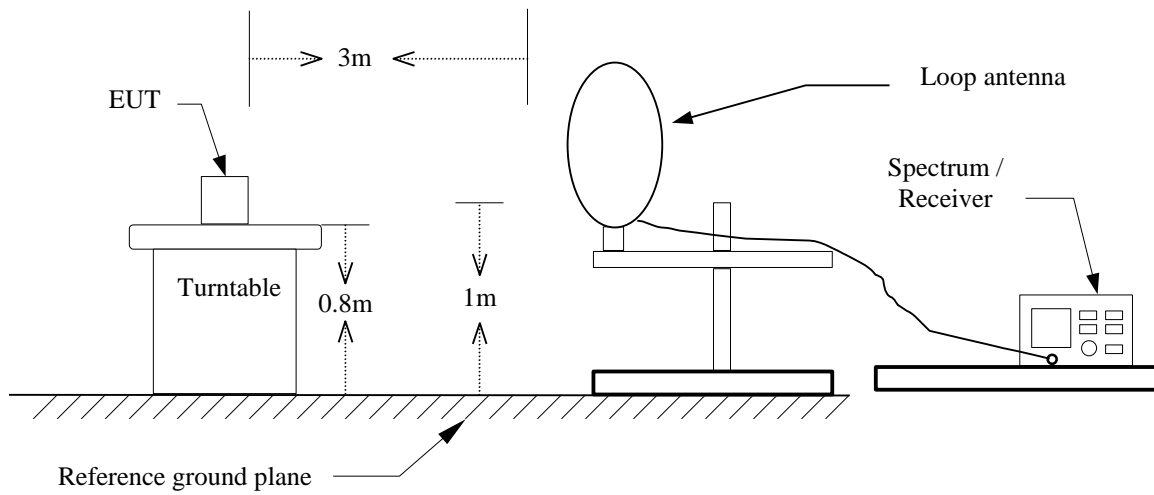

30MHz ~ 1GHz

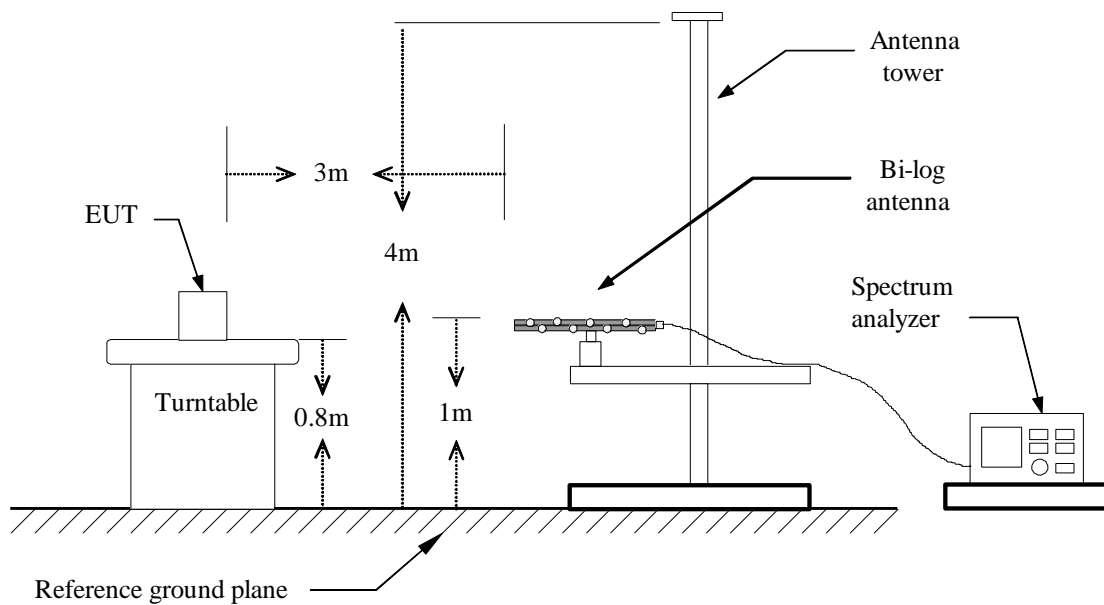



Above 1 GHz

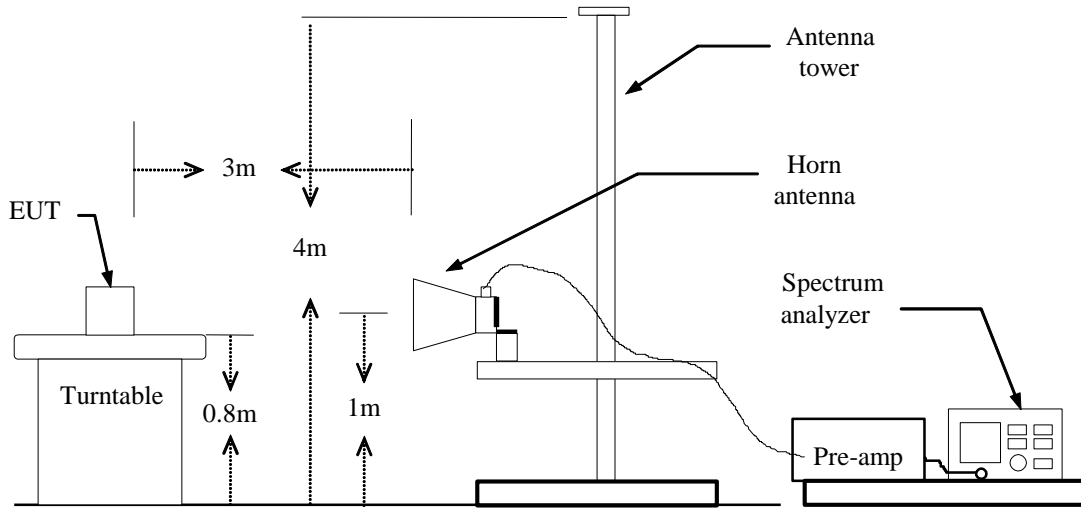



TEST PROCEDURE

1. The EUT is placed on a turntable, which is 0.8m above ground plane.
2. The turntable shall be rotated for 360 degrees to determine the position of maximum emission level.
3. EUT is set 3m away from the receiving antenna, which is varied from 1m to 4m to find out the highest emissions.
4. Maximum procedure was performed on the six highest emissions to ensure EUT compliance.
5. And also, each emission was to be maximized by changing the polarization of receiving antenna both horizontal and vertical.
6. Set the spectrum analyzer in the following setting as:

Below 1GHz:

RBW=100kHz / VBW=300kHz / Sweep=AUTO

Above 1GHz:

(a) PEAK: RBW=VBW=1MHz / Sweep=AUTO

(b) AVERAGE: RBW=1MHz / VBW=300Hz / Sweep=AUTO

7. Repeat above procedures until the measurements for all frequencies are complete.



TEST RESULTS

Below 1 GHz

Operation Mode: Normal Link

Test Date: October 22, 2014

Temperature: 27°C

Tested by: Dennis Li

Humidity: 53% RH

Polarity: Ver. / Hor.

Frequency (MHz)	Reading (dBuV)	Correction Factor (dB/m)	Result (dBuV/m)	Limit 3m (dBuV/m)	Margin (dB)	Detector Mode (PK/QP)	Ant.Pol. (H/V)
103.7200	18.21	-20.26	-2.05	43.50	-45.55	Peak	V
339.4300	14.97	-15.45	-0.48	46.00	-46.48	Peak	V
534.4000	15.48	-11.26	4.22	46.00	-41.78	Peak	V
747.8000	16.55	-7.92	8.63	46.00	-37.37	Peak	V
831.2200	15.21	-7.01	8.20	46.00	-37.80	Peak	V
980.6000	14.94	-4.99	9.95	54.00	-44.05	Peak	V
158.0400	15.06	-18.21	-3.15	43.50	-46.65	Peak	H
313.2400	16.12	-16.09	0.03	46.00	-45.97	Peak	H
497.5400	15.83	-11.87	3.96	46.00	-42.04	Peak	H
647.8900	14.35	-9.36	4.99	46.00	-41.01	Peak	H
755.5600	15.43	-7.82	7.61	46.00	-38.39	Peak	H
903.9700	15.32	-6.11	9.21	46.00	-36.79	Peak	H

Remark:

1. Measuring frequencies from 30 MHz to the 1GHz.
2. Radiated emissions measured in frequency range from 30 MHz to 1000MHz were made with an instrument using peak/quasi-peak detector mode.
3. Quasi-peak test would be performed if the peak result were greater than the quasi-peak limit or as required by the applicant.
4. Measurements above show only up to 6 maximum emissions noted, or would be lesser, with " N/A " remark, if no specific emissions from the EUT are recorded (ie: margin>20dB from the applicable limit) and considered that's already beyond the background noise floor.
5. Margin (dB) = Remark result (dBuV/m) – Quasi-peak limit (dBuV/m).



Above 1 GHz

Operation Mode: Tx / IEEE 802.11a mode / 5180 ~ 5240MHz / CH Low **Test Date:** October 22, 2014

Temperature: 27°C **Tested by:** Dennis Li

Humidity: 53% RH **Polarity:** Ver. / Hor.

Frequency (MHz)	Reading (dBuV)	Correction (dB/m)	Result (dBuV/m)	Limit (dBuV/m)	Margin (dB)	Remark	Ant.Pol. (H/V)
3457.000	51.20	-1.01	50.19	74.00	-23.81	peak	V
10360.000	35.75	16.52	52.27	74.00	-21.73	peak	V
10360.000	27.02	16.52	43.54	54.00	-10.46	AVG	V
15530.000	44.62	19.04	63.66	74.00	-10.34	peak	V
15530.000	33.70	19.04	52.74	54.00	-1.26	AVG	V
N/A							
3884.000	50.01	0.73	50.74	74.00	-23.26	peak	H
15540.000	42.64	19.04	61.68	74.00	-12.32	peak	H
15540.000	33.22	19.04	52.26	54.00	-1.74	AVG	H
N/A							

Remark:

1. Measuring frequencies from 1 GHz to the 10th harmonic of highest fundamental frequency.
2. Radiated emissions measured in frequency above 1000MHz, were made with an instrument using peak/average detector mode.
3. Average test would be performed if the peak result were greater than the average limit.
4. Data of measurement within this frequency range shown “ --- ” in the table above means the reading of emissions are attenuated more than 20dB below the permissible limits or the field strength is too small to be measured.
5. Measurements above show only up to 6 maximum emissions noted, or would be lesser, with “ N/A ” remark, if no specific emissions from the EUT are recorded (ie: margin>20dB from the applicable limit) and considered that's already beyond the background noise floor.
6. Margin (dB) = Remark result (dBuV/m) – Average limit (dBuV/m).



Operation Mode: Tx / IEEE 802.11a mode / 5180 ~ 5240MHz / CH Mid **Test Date:** October 22, 2014
Temperature: 27°C **Tested by:** Dennis Li
Humidity: 53% RH **Polarity:** Ver. / Hor.

Frequency (MHz)	Reading (dBuV)	Correction (dB/m)	Result (dBuV/m)	Limit (dBuV/m)	Margin (dB)	Remark	Ant.Pol. (H/V)
3492.000	51.11	-0.93	50.18	74.00	-23.82	peak	V
10440.000	39.11	16.89	56.00	74.00	-18.00	peak	V
10440.000	26.53	16.89	43.42	54.00	-10.58	AVG	V
15660.000	50.69	19.14	69.83	74.00	-4.17	peak	V
15660.000	32.53	19.14	51.67	54.00	-2.33	AVG	V
N/A							
3219.000	52.85	-1.58	51.27	74.00	-22.73	peak	H
15660.000	40.56	19.14	59.70	74.00	-14.30	peak	H
15660.000	33.82	19.14	52.96	74.00	-21.04	peak	H
N/A							

Remark:

1. Measuring frequencies from 1 GHz to the 10th harmonic of highest fundamental frequency.
2. Radiated emissions measured in frequency above 1000MHz were made with an instrument using peak/average detector mode.
3. Average test would be performed if the peak result were greater than the average limit.
4. Data of measurement within this frequency range shown “ --- ” in the table above means the reading of emissions are attenuated more than 20dB below the permissible limits or the field strength is too small to be measured.
5. Measurements above show only up to 6 maximum emissions noted, or would be lesser, with “ N/A ” remark, if no specific emissions from the EUT are recorded (ie: margin>20dB from the applicable limit) and considered that's already beyond the background noise floor.
6. Margin (dB) = Remark result (dBuV/m) – Average limit (dBuV/m).



Operation Mode: Tx / IEEE 802.11a mode / 5180 ~ 5240MHz / CH High **Test Date:** October 22, 2014
Temperature: 27°C **Tested by:** Dennis Li
Humidity: 53% RH **Polarity:** Ver. / Hor.

Frequency (MHz)	Reading (dBuV)	Correction (dB/m)	Result (dBuV/m)	Limit (dBuV/m)	Margin (dB)	Remark	Ant.Pol. (H/V)
3296.000	51.12	-1.40	49.72	74.00	-24.28	peak	V
15720.000	43.58	19.19	62.77	74.00	-11.23	peak	V
15720.000	32.83	19.19	52.02	54.00	-1.98	AVG	V
N/A							
3968.000	49.82	1.09	50.91	74.00	-23.09	peak	H
15720.000	41.22	19.19	60.41	74.00	-13.59	peak	H
15720.000	33.30	19.19	52.49	54.00	-1.51	AVG	H
N/A							

Remark:

1. Measuring frequencies from 1 GHz to the 10th harmonic of highest fundamental frequency.
2. Radiated emissions measured in frequency above 1000MHz were made with an instrument using peak/average detector mode.
3. Average test would be performed if the peak result were greater than the average limit.
4. Data of measurement within this frequency range shown “ --- ” in the table above means the reading of emissions are attenuated more than 20dB below the permissible limits or the field strength is too small to be measured.
5. Measurements above show only up to 6 maximum emissions noted, or would be lesser, with “ N/A ” remark, if no specific emissions from the EUT are recorded (ie: margin>20dB from the applicable limit) and considered that's already beyond the background noise floor.
6. Margin (dB) = Remark result (dBuV/m) – Average limit (dBuV/m).



Operation Mode: Tx / IEEE 802.11n HT 20 mode / 5180 ~ 5240MHz / CH Low

Test Date: October 22, 2014

Temperature: 27°C

Tested by: Dennis Li

Humidity: 53% RH

Polarity: Ver. / Hor.

Frequency (MHz)	Reading (dBuV)	Correction (dB/m)	Result (dBuV/m)	Limit (dBuV/m)	Margin (dB)	Remark	Ant.Pol. (H/V)
3380.000	51.87	-1.20	50.67	74.00	-23.33	peak	V
10360.000	39.11	16.52	55.63	74.00	-18.37	peak	V
10360.000	30.68	16.52	47.20	54.00	-6.80	AVG	V
15540.000	40.84	19.04	59.88	74.00	-14.12	peak	V
15540.000	30.71	19.04	49.75	54.00	-4.25	AVG	V
N/A							
3324.000	52.60	-1.33	51.27	74.00	-22.73	peak	H
10360.000	35.89	16.52	52.41	74.00	-21.59	peak	H
10360.000	29.42	16.52	45.94	54.00	-8.06	AVG	H
15540.000	42.07	19.04	61.11	74.00	-12.89	peak	H
15540.000	32.88	19.04	51.92	54.00	-2.08	AVG	H
N/A							

Remark:

1. Measuring frequencies from 1 GHz to the 10th harmonic of highest fundamental frequency.
2. Radiated emissions measured in frequency above 1000MHz were made with an instrument using peak/average detector mode.
3. Average test would be performed if the peak result were greater than the average limit.
4. Data of measurement within this frequency range shown " --- " in the table above means the reading of emissions are attenuated more than 20dB below the permissible limits or the field strength is too small to be measured.
5. Measurements above show only up to 6 maximum emissions noted, or would be lesser, with " N/A " remark, if no specific emissions from the EUT are recorded (ie: margin>20dB from the applicable limit) and considered that's already beyond the background noise floor.
6. Margin (dB) = Remark result (dBuV/m) – Average limit (dBuV/m).



Operation Mode: Tx / IEEE 802.11n HT 20 mode / 5180 ~ 5240MHz / CH Mid

Test Date: October 22, 2014

Temperature: 27°C

Tested by: Dennis Li

Humidity: 53% RH

Polarity: Ver. / Hor.

Frequency (MHz)	Reading (dBuV)	Correction (dB/m)	Result (dBuV/m)	Limit (dBuV/m)	Margin (dB)	Remark	Ant.Pol. (H/V)
3233.000	51.87	-1.55	50.32	74.00	-23.68	peak	V
10440.000	39.66	16.89	56.55	74.00	-17.45	peak	V
10440.000	29.53	16.89	46.42	54.00	-7.58	AVG	V
15670.000	39.79	19.15	58.94	74.00	-15.06	peak	V
15670.000	32.44	19.15	51.59	54.00	-2.41	AVG	V
N/A							
3345.000	52.65	-1.28	51.37	74.00	-22.63	peak	H
15660.000	43.05	19.14	62.19	74.00	-11.81	peak	H
15660.000	32.42	19.14	51.56	54.00	-2.44	AVG	H
N/A							

Remark:

1. Measuring frequencies from 1 GHz to the 10th harmonic of highest fundamental frequency.
2. Radiated emissions measured in frequency above 1000MHz were made with an instrument using peak/average detector mode.
3. Average test would be performed if the peak result were greater than the average limit.
4. Data of measurement within this frequency range shown “ --- ” in the table above means the reading of emissions are attenuated more than 20dB below the permissible limits or the field strength is too small to be measured.
5. Measurements above show only up to 6 maximum emissions noted, or would be lesser, with “ N/A ” remark, if no specific emissions from the EUT are recorded (ie: margin>20dB from the applicable limit) and considered that's already beyond the background noise floor.
6. Margin (dB) = Remark result (dBuV/m) – Average limit (dBuV/m).



Operation Mode: Tx / IEEE 802.11n HT 20 mode / 5180 ~ 5240MHz / CH High

Test Date: October 22, 2014

Temperature: 27°C

Tested by: Dennis Li

Humidity: 53% RH

Polarity: Ver. / Hor.

Frequency (MHz)	Reading (dBuV)	Correction (dB/m)	Result (dBuV/m)	Limit (dBuV/m)	Margin (dB)	Remark	Ant.Pol. (H/V)
3359.000	51.93	-1.25	50.68	74.00	-23.32	peak	V
10480.000	36.10	17.07	53.17	74.00	-20.83	peak	V
10480.000	30.48	17.07	47.55	54.00	-6.45	AVG	V
15720.000	36.82	19.19	56.01	74.00	-17.99	peak	V
15720.000	27.32	19.19	46.51	54.00	-7.49	AVG	V
N/A							
3156.000	52.18	-1.74	50.44	74.00	-23.56	peak	H
10480.000	35.61	17.07	52.68	74.00	-21.32	peak	H
10480.000	29.51	17.07	46.58	54.00	-7.42	AVG	H
15720.000	40.53	19.19	59.72	74.00	-14.28	peak	H
15720.000	32.56	19.19	51.75	54.00	-2.25	AVG	H
N/A							H

Remark:

1. Measuring frequencies from 1 GHz to the 10th harmonic of highest fundamental frequency.
2. Radiated emissions measured in frequency above 1000MHz were made with an instrument using peak/average detector mode.
3. Average test would be performed if the peak result were greater than the average limit.
4. Data of measurement within this frequency range shown “ --- ” in the table above means the reading of emissions are attenuated more than 20dB below the permissible limits or the field strength is too small to be measured.
5. Measurements above show only up to 6 maximum emissions noted, or would be lesser, with “ N/A ” remark, if no specific emissions from the EUT are recorded (ie: margin>20dB from the applicable limit) and considered that's already beyond the background noise floor.
6. Margin (dB) = Remark result (dBuV/m) – Average limit (dBuV/m).



Operation Mode: Tx / IEEE 802.11n HT 40 mode / 5190 ~ 5230MHz / CH Low

Test Date: October 22, 2014

Temperature: 27°C

Tested by: Dennis Li

Humidity: 53% RH

Polarity: Ver. / Hor.

Frequency (MHz)	Reading (dBuV)	Correction (dB/m)	Result (dBuV/m)	Limit (dBuV/m)	Margin (dB)	Remark	Ant.Pol. (H/V)
3233.000	51.80	-1.55	50.25	74.00	-23.75	peak	V
10390.000	38.38	16.66	55.04	74.00	-18.96	peak	V
10390.000	29.81	16.66	46.47	54.00	-7.53	AVG	V
15570.000	38.33	19.07	57.40	74.00	-16.60	peak	V
15570.000	29.39	19.07	48.46	54.00	-5.54	AVG	V
N/A							
3247.000	51.53	-1.52	50.01	74.00	-23.99	peak	H
10380.000	38.84	16.62	55.46	74.00	-18.54	peak	H
10380.000	29.20	16.62	45.82	54.00	-8.18	AVG	H
15570.000	46.99	19.07	66.06	74.00	-7.94	peak	H
15570.000	32.16	19.07	51.23	54.00	-2.77	AVG	H
N/A							

Remark:

1. Measuring frequencies from 1 GHz to the 10th harmonic of highest fundamental frequency.
2. Radiated emissions measured in frequency above 1000MHz were made with an instrument using peak/average detector mode.
3. Average test would be performed if the peak result were greater than the average limit.
4. Data of measurement within this frequency range shown " --- " in the table above means the reading of emissions are attenuated more than 20dB below the permissible limits or the field strength is too small to be measured.
5. Measurements above show only up to 6 maximum emissions noted, or would be lesser, with " N/A " remark, if no specific emissions from the EUT are recorded (ie: margin>20dB from the applicable limit) and considered that's already beyond the background noise floor.
6. Margin (dB) = Remark result (dBuV/m) – Average limit (dBuV/m).



Operation Mode: Tx / IEEE 802.11n HT 40 mode / 5190 ~ 5230MHz / CH High

Test Date: October 22, 2014

Temperature: 27°C

Tested by: Dennis Li

Humidity: 53% RH

Polarity: Ver. / Hor.

Frequency (MHz)	Reading (dBuV)	Correction (dB/m)	Result (dBuV/m)	Limit (dBuV/m)	Margin (dB)	Remark	Ant.Pol. (H/V)
3268.000	51.85	-1.47	50.38	74.00	-23.62	peak	V
10460.000	38.16	16.98	55.14	74.00	-18.86	peak	V
10460.000	29.42	16.98	46.40	54.00	-7.60	AVG	V
15690.000	41.58	19.17	60.75	74.00	-13.25	peak	V
15690.000	31.78	19.17	50.95	54.00	-3.05	AVG	V
N/A							
3562.000	50.56	-0.64	49.92	74.00	-24.08	peak	H
10460.000	35.99	16.98	52.97	74.00	-21.03	peak	H
10460.000	29.74	16.98	46.72	54.00	-7.28	AVG	H
15690.000	39.31	19.17	58.48	74.00	-15.52	peak	H
15690.000	32.50	19.17	51.67	54.00	-2.33	AVG	H
N/A							

Remark:

1. Measuring frequencies from 1 GHz to the 10th harmonic of highest fundamental frequency.
2. Radiated emissions measured in frequency above 1000MHz were made with an instrument using peak/average detector mode.
3. Average test would be performed if the peak result were greater than the average limit.
4. Data of measurement within this frequency range shown " --- " in the table above means the reading of emissions are attenuated more than 20dB below the permissible limits or the field strength is too small to be measured.
5. Measurements above show only up to 6 maximum emissions noted, or would be lesser, with " N/A " remark, if no specific emissions from the EUT are recorded (ie: margin>20dB from the applicable limit) and considered that's already beyond the background noise floor.
6. Margin (dB) = Remark result (dBuV/m) – Average limit (dBuV/m).



Operation Mode: Tx / IEEE 802.11ac VHT80 Mode / 5210MHz / CH Mid **Test Date:** October 22, 2014
Temperature: 27°C **Tested by:** Dennis Li
Humidity: 53% RH **Polarity:** Ver. / Hor.

Frequency (MHz)	Reading (dBuV)	Correction (dB/m)	Result (dBuV/m)	Limit (dBuV/m)	Margin (dB)	Remark	Ant.Pol. (H/V)
3065.000	51.01	-1.95	49.06	74.00	-24.94	peak	V
N/A							
3317.000	51.89	-1.35	50.54	74.00	-23.46	peak	H
N/A							

Remark:

1. Measuring frequencies from 1 GHz to the 10th harmonic of highest fundamental frequency.
2. Radiated emissions measured in frequency above 1000MHz were made with an instrument using peak/average detector mode.
3. Average test would be performed if the peak result were greater than the average limit.
4. Data of measurement within this frequency range shown “ --- ” in the table above means the reading of emissions are attenuated more than 20dB below the permissible limits or the field strength is too small to be measured.
5. Measurements above show only up to 6 maximum emissions noted, or would be lesser, with “ N/A ” remark, if no specific emissions from the EUT are recorded (ie: margin>20dB from the applicable limit) and considered that's already beyond the background noise floor.
6. Margin (dB) = Remark result (dBuV/m) – Average limit (dBuV/m).



Operation Mode: Tx / IEEE 802.11a mode / 5745 ~ 5825MHz / CH Low **Test Date:** October 22, 2014
Temperature: 27°C **Tested by:** Dennis Li
Humidity: 53% RH **Polarity:** Ver. / Hor.

Frequency (MHz)	Reading (dBuV)	Correction (dB/m)	Result (dBuV/m)	Limit (dBuV/m)	Margin (dB)	Remark	Ant.Pol. (H/V)
3205.000	52.63	-1.62	51.01	74.00	-22.99	peak	V
11490.000	38.18	16.78	54.96	74.00	-19.04	peak	V
11490.000	31.09	16.78	47.87	54.00	-6.13	AVG	V
N/A							
3233.000	52.06	-1.55	50.51	74.00	-23.49	peak	H
11500.000	41.46	16.78	58.24	74.00	-15.76	peak	H
11500.000	29.81	16.78	46.59	54.00	-7.41	AVG	H
17240.000	40.45	25.30	65.75	74.00	-8.25	peak	H
17240.000	26.00	25.30	51.30	54.00	-2.70	AVG	H
N/A							

Remark:

1. Measuring frequencies from 1 GHz to the 10th harmonic of highest fundamental frequency.
2. Radiated emissions measured in frequency above 1000MHz were made with an instrument using peak/average detector mode.
3. Average test would be performed if the peak result were greater than the average limit.
4. Data of measurement within this frequency range shown “ --- ” in the table above means the reading of emissions are attenuated more than 20dB below the permissible limits or the field strength is too small to be measured.
5. Measurements above show only up to 6 maximum emissions noted, or would be lesser, with “ N/A ” remark, if no specific emissions from the EUT are recorded (ie: margin>20dB from the applicable limit) and considered that's already beyond the background noise floor.
6. Margin (dB) = Remark result (dBuV/m) – Average limit (dBuV/m).



Operation Mode: Tx / IEEE 802.11a mode / 5745 ~ 5825MHz / CH Mid **Test Date:** October 22, 2014
Temperature: 27°C **Tested by:** Dennis Li
Humidity: 53% RH **Polarity:** Ver. / Hor.

Frequency (MHz)	Reading (dBuV)	Correction (dB/m)	Result (dBuV/m)	Limit (dBuV/m)	Margin (dB)	Remark	Ant.Pol. (H/V)
3289.000	51.16	-1.42	49.74	74.00	-24.26	peak	V
11570.000	40.98	16.84	57.82	74.00	-16.18	peak	V
11570.000	34.90	16.84	51.74	54.00	-2.26	AVG	V
N/A							
3233.000	51.73	-1.55	50.18	74.00	-23.82	peak	H
11570.000	41.40	16.84	58.24	74.00	-15.76	peak	H
11570.000	31.95	16.84	48.79	54.00	-5.21	AVG	H
17350.000	38.18	25.73	63.91	74.00	-10.09	peak	H
17350.000	26.25	25.73	51.98	54.00	-2.02	AVG	H
N/A							

Remark:

1. Measuring frequencies from 1 GHz to the 10th harmonic of highest fundamental frequency.
2. Radiated emissions measured in frequency above 1000MHz were made with an instrument using peak/average detector mode.
3. Average test would be performed if the peak result were greater than the average limit.
4. Data of measurement within this frequency range shown “ --- ” in the table above means the reading of emissions are attenuated more than 20dB below the permissible limits or the field strength is too small to be measured.
5. Measurements above show only up to 6 maximum emissions noted, or would be lesser, with “ N/A ” remark, if no specific emissions from the EUT are recorded (ie: margin>20dB from the applicable limit) and considered that's already beyond the background noise floor.
6. Margin (dB) = Remark result (dBuV/m) – Average limit (dBuV/m).



Operation Mode: Tx / IEEE 802.11a mode / 5745 ~ 5825MHz / CH High

Test Date: October 22, 2014

Temperature: 27°C

Tested by: Dennis Li

Humidity: 53% RH

Polarity: Ver. / Hor.

Frequency (MHz)	Reading (dBuV)	Correction (dB/m)	Result (dBuV/m)	Limit (dBuV/m)	Margin (dB)	Remark	Ant.Pol. (H/V)
3212.000	51.75	-1.60	50.15	74.00	-23.85	peak	V
11650.000	37.68	16.91	54.59	74.00	-19.41	peak	V
11650.000	30.79	16.91	47.70	54.00	-6.30	AVG	V
N/A							
3051.000	51.91	-1.99	49.92	74.00	-24.08	peak	H
11650.000	37.08	16.91	53.99	74.00	-20.01	peak	H
11650.000	27.41	16.91	44.32	54.00	-9.68	AVG	H
17480.000	34.22	26.24	60.46	74.00	-13.54	peak	H
17480.000	25.47	26.24	51.71	54.00	-2.29	AVG	H
N/A							

Remark:

1. Measuring frequencies from 1 GHz to the 10th harmonic of highest fundamental frequency.
2. Radiated emissions measured in frequency above 1000MHz were made with an instrument using peak/average detector mode.
3. Average test would be performed if the peak result were greater than the average limit.
4. Data of measurement within this frequency range shown " --- " in the table above means the reading of emissions are attenuated more than 20dB below the permissible limits or the field strength is too small to be measured.
5. Measurements above show only up to 6 maximum emissions noted, or would be lesser, with " N/A " remark, if no specific emissions from the EUT are recorded (ie: margin>20dB from the applicable limit) and considered that's already beyond the background noise floor.
6. Margin (dB) = Remark result (dBuV/m) – Average limit (dBuV/m).



Operation Mode: Tx / IEEE 802.11n HT 20 mode / 5745 ~ 5825MHz / CH Low

Test Date: October 22, 2014

Temperature: 27°C

Tested by: Dennis Li

Humidity: 53% RH

Polarity: Ver. / Hor.

Frequency (MHz)	Reading (dBuV)	Correction (dB/m)	Result (dBuV/m)	Limit (dBuV/m)	Margin (dB)	Remark	Ant.Pol. (H/V)
3275.000	51.81	-1.45	50.36	74.00	-23.64	peak	V
11490.000	36.54	16.78	53.32	74.00	-20.68	peak	V
11490.000	27.50	16.78	44.28	54.00	-9.72	AVG	V
N/A							
3198.000	52.08	-1.63	50.45	74.00	-23.55	peak	H
17240.000	42.02	25.30	67.32	74.00	-6.68	peak	H
17240.000	26.26	25.30	51.56	54.00	-2.44	AVG	H
N/A							

Remark:

1. Measuring frequencies from 1 GHz to the 10th harmonic of highest fundamental frequency.
2. Radiated emissions measured in frequency above 1000MHz were made with an instrument using peak/average detector mode.
3. Average test would be performed if the peak result were greater than the average limit.
4. Data of measurement within this frequency range shown “ --- ” in the table above means the reading of emissions are attenuated more than 20dB below the permissible limits or the field strength is too small to be measured.
5. Measurements above show only up to 6 maximum emissions noted, or would be lesser, with “ N/A ” remark, if no specific emissions from the EUT are recorded (ie: margin>20dB from the applicable limit) and considered that's already beyond the background noise floor.
6. Margin (dB) = Remark result (dBuV/m) – Average limit (dBuV/m).



Operation Mode: Tx / IEEE 802.11n HT 20 mode / 5745 ~ 5825MHz / CH Mid

Test Date: October 22, 2014

Temperature: 27°C

Tested by: Dennis Li

Humidity: 53% RH

Polarity: Ver. / Hor.

Frequency (MHz)	Reading (dBuV)	Correction (dB/m)	Result (dBuV/m)	Limit (dBuV/m)	Margin (dB)	Remark	Ant.Pol. (H/V)
3947.000	49.79	1.00	50.79	74.00	-23.21	peak	V
11570.000	37.87	16.84	54.71	74.00	-19.29	peak	V
11570.000	30.21	16.84	47.05	54.00	-6.95	AVG	V
N/A							
3177.000	52.00	-1.69	50.31	74.00	-23.69	peak	H
17360.000	36.58	25.77	62.35	74.00	-11.65	peak	H
17360.000	26.52	25.77	52.29	54.00	-1.71	AVG	H
N/A							

Remark:

1. Measuring frequencies from 1 GHz to the 10th harmonic of highest fundamental frequency.
2. Radiated emissions measured in frequency above 1000MHz were made with an instrument using peak/average detector mode.
3. Average test would be performed if the peak result were greater than the average limit.
4. Data of measurement within this frequency range shown “ --- ” in the table above means the reading of emissions are attenuated more than 20dB below the permissible limits or the field strength is too small to be measured.
5. Measurements above show only up to 6 maximum emissions noted, or would be lesser, with “ N/A ” remark, if no specific emissions from the EUT are recorded (ie: margin>20dB from the applicable limit) and considered that's already beyond the background noise floor.
6. Margin (dB) = Remark result (dBuV/m) – Average limit (dBuV/m).



Operation Mode: Tx / IEEE 802.11n HT 20 mode / 5745 ~ 5825MHz / CH High

Test Date: October 22, 2014

Temperature: 27°C

Tested by: Dennis Li

Humidity: 53% RH

Polarity: Ver. / Hor.

Frequency (MHz)	Reading (dBuV)	Correction (dB/m)	Result (dBuV/m)	Limit (dBuV/m)	Margin (dB)	Remark	Ant.Pol. (H/V)
3331.000	51.70	-1.32	50.38	74.00	-23.62	peak	V
11660.000	34.62	16.92	51.54	74.00	-22.46	peak	V
11660.000	28.30	16.92	45.22	54.00	-8.78	AVG	V
N/A							
3184.000	52.33	-1.67	50.66	74.00	-23.34	peak	H
17480.000	34.43	26.24	60.67	74.00	-13.33	peak	H
17480.000	25.83	26.24	52.07	54.00	-1.93	AVG	H
N/A							

Remark:

1. Measuring frequencies from 1 GHz to the 10th harmonic of highest fundamental frequency.
2. Radiated emissions measured in frequency above 1000MHz were made with an instrument using peak/average detector mode.
3. Average test would be performed if the peak result were greater than the average limit.
4. Data of measurement within this frequency range shown “ --- ” in the table above means the reading of emissions are attenuated more than 20dB below the permissible limits or the field strength is too small to be measured.
5. Measurements above show only up to 6 maximum emissions noted, or would be lesser, with “ N/A ” remark, if no specific emissions from the EUT are recorded (ie: margin>20dB from the applicable limit) and considered that's already beyond the background noise floor.
6. Margin (dB) = Remark result (dBuV/m) – Average limit (dBuV/m).



Operation Mode: Tx / IEEE 802.11n HT 40 mode / 5755 ~ 5795MHz / CH Low

Test Date: October 22, 2014

Temperature: 27°C

Tested by: Dennis Li

Humidity: 53% RH

Polarity: Ver. / Hor.

Frequency (MHz)	Reading (dBuV)	Correction (dB/m)	Result (dBuV/m)	Limit (dBuV/m)	Margin (dB)	Remark	Ant.Pol. (H/V)
4052.000	50.63	1.43	52.06	74.00	-21.94	peak	V
11500.000	35.69	16.78	52.47	74.00	-21.53	peak	V
11500.000	29.58	16.78	46.36	54.00	-7.64	AVG	V
N/A							
3387.000	51.13	-1.18	49.95	74.00	-24.05	peak	H
17270.000	41.23	25.42	66.65	74.00	-7.35	peak	H
17270.000	26.62	25.42	52.04	54.00	-1.96	AVG	H
N/A							

Remark:

1. Measuring frequencies from 1 GHz to the 10th harmonic of highest fundamental frequency.
2. Radiated emissions measured in frequency above 1000MHz were made with an instrument using peak/average detector mode.
3. Average test would be performed if the peak result were greater than the average limit.
4. Data of measurement within this frequency range shown “ --- ” in the table above means the reading of emissions are attenuated more than 20dB below the permissible limits or the field strength is too small to be measured.
5. Measurements above show only up to 6 maximum emissions noted, or would be lesser, with “ N/A ” remark, if no specific emissions from the EUT are recorded (ie: margin>20dB from the applicable limit) and considered that's already beyond the background noise floor.
6. Margin (dB) = Remark result (dBuV/m) – Average limit (dBuV/m).



Operation Mode: Tx / IEEE 802.11n HT 40 mode / 5755 ~ 5795MHz / CH High

Test Date: October 22, 2014

Temperature: 27°C

Tested by: Dennis Li

Humidity: 53% RH

Polarity: Ver. / Hor.

Frequency (MHz)	Reading (dBuV)	Correction (dB/m)	Result (dBuV/m)	Limit (dBuV/m)	Margin (dB)	Remark	Ant.Pol. (H/V)
3793.000	49.95	0.34	50.29	74.00	-23.71	peak	V
11590.000	35.87	16.86	52.73	74.00	-21.27	peak	V
11590.000	27.82	16.86	44.68	54.00	-9.32	AVG	V
N/A							
3240.000	52.18	-1.53	50.65	74.00	-23.35	peak	H
17380.000	34.94	25.85	60.79	74.00	-13.21	peak	H
17380.000	26.01	25.85	51.86	54.00	-2.14	AVG	H
N/A							

Remark:

1. Measuring frequencies from 1 GHz to the 10th harmonic of highest fundamental frequency.
2. Radiated emissions measured in frequency above 1000MHz were made with an instrument using peak/average detector mode.
3. Average test would be performed if the peak result were greater than the average limit.
4. Data of measurement within this frequency range shown “ --- ” in the table above means the reading of emissions are attenuated more than 20dB below the permissible limits or the field strength is too small to be measured.
5. Measurements above show only up to 6 maximum emissions noted, or would be lesser, with “ N/A ” remark, if no specific emissions from the EUT are recorded (ie: margin>20dB from the applicable limit) and considered that's already beyond the background noise floor.
6. Margin (dB) = Remark result (dBuV/m) – Average limit (dBuV/m).



Operation Mode: Tx / IEEE 802.11ac VHT80 Mode / 5775MHz / CH Mid **Test Date:** October 22, 2014
Temperature: 27°C **Tested by:** Dennis Li
Humidity: 53% RH **Polarity:** Ver. / Hor.

Frequency (MHz)	Reading (dBuV)	Correction (dB/m)	Result (dBuV/m)	Limit (dBuV/m)	Margin (dB)	Remark	Ant.Pol. (H/V)
3331.000	51.17	-1.32	49.85	74.00	-24.15	peak	V
11540.000	36.63	16.82	53.45	74.00	-20.55	peak	V
11540.000	28.06	16.82	44.88	54.00	-9.12	AVG	V
N/A							
2757.000	49.26	-2.60	46.66	74.00	-27.34	peak	H
17280.000	36.79	25.46	62.25	74.00	-11.75	peak	H
17280.000	24.58	25.46	50.04	54.00	-3.96	AVG	H
N/A							

Remark:

1. Measuring frequencies from 1 GHz to the 10th harmonic of highest fundamental frequency.
2. Radiated emissions measured in frequency above 1000MHz were made with an instrument using peak/average detector mode.
3. Average test would be performed if the peak result were greater than the average limit or as required by the applicant.
4. Data of measurement within this frequency range shown “ --- ” in the table above means the reading of emissions are attenuated more than 20dB below the permissible limits or the field strength is too small to be measured.
5. Measurements above show only up to 6 maximum emissions noted, or would be lesser, with “ N/A ” remark, if no specific emissions from the EUT are recorded (ie: margin>20dB from the applicable limit) and considered that's already beyond the background noise floor.
6. Margin (dB) = Remark result (dBuV/m) – Average limit (dBuV/m).



7.6 POWERLINE CONDUCTED EMISSIONS

LIMIT

According to §15.207(a), except as shown in paragraphs (b) and (c) of this section, for an intentional radiator that is designed to be connected to the public utility (AC) power line, the radio frequency voltage that is conducted back onto the AC power line on any frequency or frequencies within the band 150 kHz to 30 MHz shall not exceed the limits in the following table, as measured using a 50 μ H/50 ohms line impedance stabilization network (LISN). Compliance with the provisions of this paragraph shall be based on the measurement of the radio frequency voltage between each power line and ground at the power terminal. The lower limit applies at the boundary between the frequency ranges.

Frequency Range (MHz)	Limits (dB μ V)	
	Quasi-peak	Average
0.15 to 0.50	66 to 56*	56 to 46*
0.50 to 5	56	46
5 to 30	60	50

* Decreases with the logarithm of the frequency.

TEST CONFIGURATION

See test photographs attached in Appendix 1 for the actual connections between EUT and support equipment.

TEST PROCEDURE

1. The EUT was placed on a table, which is 0.8m above ground plane.
2. Maximum procedure was performed on the six highest emissions to ensure EUT compliance.
3. Repeat above procedures until all frequency measured were complete.



TEST RESULTS

The initial step in collecting conducted data is a spectrum analyzer peak scan of the measurement range. Significant peaks are then marked as shown on the following data page, and these signals are then quasi-peaked.

Test Data

Operation Mode: Normal Link **Test Date:** October 10, 2014

Temperature: 24°C **Tested by:** Bland Cheng

Humidity: 50% RH

Freq. (MHz)	QP Reading (dBuV)	AV Reading (dBuV)	Corr. factor (dB/m)	QP Result (dBuV/m)	AV Result (dBuV/m)	QP Limit (dBuV)	AV Limit (dBuV)	QP Margin (dB)	AV Margin (dB)	Note
0.2800	39.13	25.51	9.63	48.76	35.14	60.81	50.82	-12.05	-15.68	L1
0.6980	32.89	18.63	9.67	42.56	28.30	56.00	46.00	-13.44	-17.70	L1
0.7980	29.80	14.29	9.69	39.49	23.98	56.00	46.00	-16.51	-22.02	L1
1.4900	29.23	13.93	9.73	38.96	23.66	56.00	46.00	-17.04	-22.34	L1
1.7620	29.47	14.33	9.74	39.21	24.07	56.00	46.00	-16.79	-21.93	L1
2.0500	29.67	14.75	9.75	39.42	24.50	56.00	46.00	-16.58	-21.50	L1
0.2860	38.90	26.56	9.68	48.58	36.24	60.64	50.64	-12.06	-14.40	L2
0.5060	33.29	17.43	9.71	43.00	27.14	56.00	46.00	-13.00	-18.86	L2
0.8460	31.27	14.85	9.75	41.02	24.60	56.00	46.00	-14.98	-21.40	L2
1.2220	29.89	15.30	9.77	39.66	25.07	56.00	46.00	-16.34	-20.93	L2
1.3540	30.23	14.90	9.77	40.00	24.67	56.00	46.00	-16.00	-21.33	L2
2.3100	28.35	13.50	9.82	38.17	23.32	56.00	46.00	-17.83	-22.68	L2

Remark:

1. Measuring frequencies from 0.15 MHz to 30MHz.
2. The emissions measured in frequency range from 0.15 MHz to 30MHz were made with an instrument using Quasi-peak detector and average detector.
3. The IF bandwidth of SPA between 0.15MHz to 30MHz was 10kHz; the IF bandwidth of Test Receiver between 0.15MHz to 30MHz was 9kHz;
4. L1 = Line One (Live Line) / L2 = Line Two (Neutral Line)



Test Plots

Conducted emissions (Line 1)

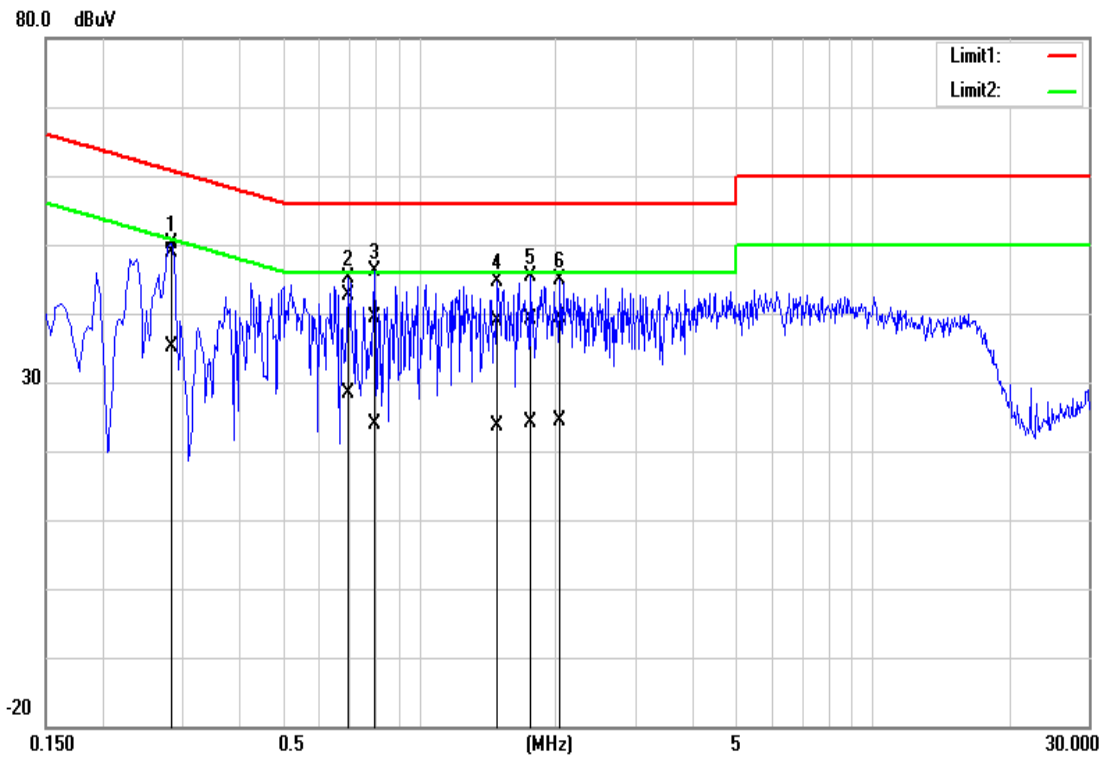

Conducted emissions (Line 2)

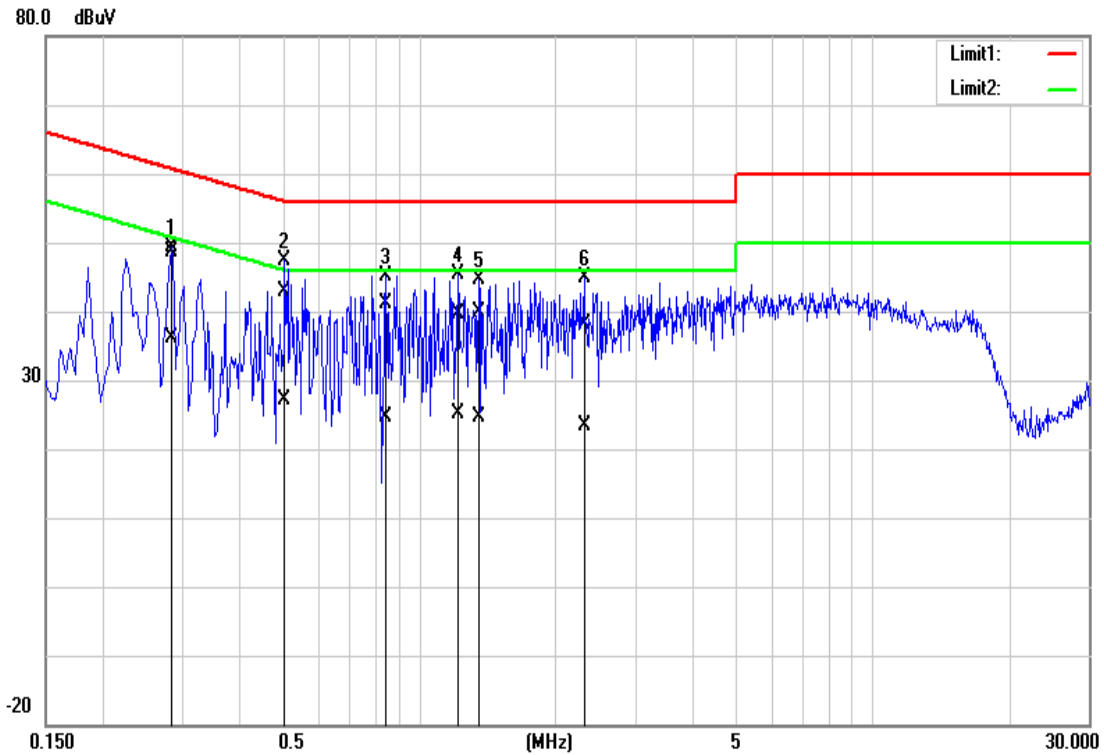



7.7 FREQUENCY STABILITY

LIMIT

According to §15.407(g), manufacturers of U-NII devices are responsible for ensuring frequency stability such that an emission is maintained within the band of operation under all conditions of normal operation as specified in the user's manual.

Test Configuration

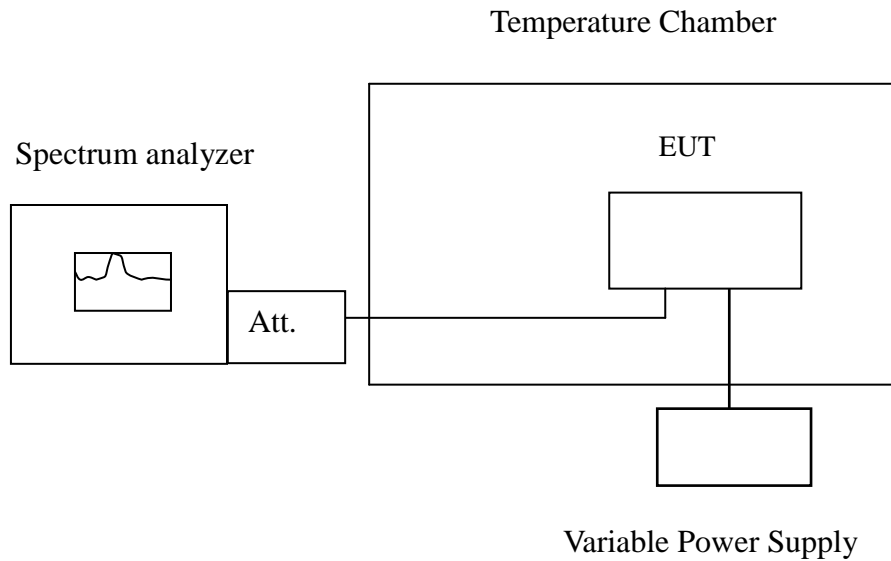

Remark: Measurement setup for testing on Antenna connector



TEST PROCEDURE

The equipment under test was connected to an external AC or DC power supply and input rated voltage. RF output was connected to a frequency counter or spectrum analyzer via feed through attenuators. The EUT was placed inside the temperature chamber. Set the spectrum analyzer RBW low enough to obtain the desired frequency resolution and measure EUT 20°C operating frequency as reference frequency. Turn EUT off and set the chamber temperature to -20°C. After the temperature stabilized for approximately 30 minutes recorded the frequency. Repeat step measure with 10°C increased per stage until the highest temperature of +50°C reached.

TEST RESULTS

No non-compliance noted.

IEEE 802.11a mode / 5180 ~ 5240 MHz:

CH Low

Operating Frequency: 5180 MHz				
Environment Temperature (°C)	Voltage (V)	Measured Frequency (MHz)	Limit Range	Test Result
50	110	5180.008393	5150~5250	Pass
40	110	5180.002626	5150~5250	Pass
30	110	5179.994113	5150~5250	Pass
20	110	5180.010832	5150~5250	Pass
10	110	5179.996620	5150~5250	Pass
0	110	5180.000061	5150~5250	Pass
-10	110	5180.002289	5150~5250	Pass
-20	110	5180.001585	5150~5250	Pass

Operating Frequency: 5180 MHz				
Environment Temperature (°C)	Voltage (V)	Measured Frequency (MHz)	Limit Range	Test Result
20	99	5180.004054	5150~5250	Pass
	110	5180.005435	5150~5250	Pass
	121	5179.995769	5150~5250	Pass



CH Mid

Operating Frequency: 5220 MHz				
Environment Temperature (°C)	Voltage (V)	Measured Frequency (MHz)	Limit Range	Test Result
50	110	5220.000852	5150~5250	Pass
40	110	5220.007641	5150~5250	Pass
30	110	5220.009987	5150~5250	Pass
20	110	5219.990009	5150~5250	Pass
10	110	5220.000728	5150~5250	Pass
0	110	5219.996277	5150~5250	Pass
-10	110	5219.997740	5150~5250	Pass
-20	110	5220.006504	5150~5250	Pass

Operating Frequency: 5220 MHz				
Environment Temperature (°C)	Voltage (V)	Measured Frequency (MHz)	Limit Range	Test Result
20	99	5220.003838	5150~5250	Pass
	110	5219.99423	5150~5250	Pass
	121	5219.998909	5150~5250	Pass



CH High

Operating Frequency: 5240 MHz				
Environment Temperature (°C)	Voltage (V)	Measured Frequency (MHz)	Limit Range	Test Result
50	110	5240.003563	5150~5250	Pass
40	110	5240.004442	5150~5250	Pass
30	110	5240.004136	5150~5250	Pass
20	110	5240.001230	5150~5250	Pass
10	110	5240.005223	5150~5250	Pass
0	110	5240.009154	5150~5250	Pass
-10	110	5239.992412	5150~5250	Pass
-20	110	5239.991230	5150~5250	Pass

Operating Frequency: 5240 MHz				
Environment Temperature (°C)	Voltage (V)	Measured Frequency (MHz)	Limit Range	Test Result
20	99	5239.994968	5150~5250	Pass
	110	5240.009584	5150~5250	Pass
	121	5239.993224	5150~5250	Pass



IEEE 802.11n HT 20 mode / 5180 ~ 5240 MHz / Chain 0:

CH Low

Operating Frequency: 5180 MHz				
Environment Temperature (°C)	Voltage (V)	Measured Frequency (MHz)	Limit Range	Test Result
50	110	5180.001352	5150~5250	Pass
40	110	5180.010440	5150~5250	Pass
30	110	5179.993713	5150~5250	Pass
20	110	5179.998123	5150~5250	Pass
10	110	5180.001233	5150~5250	Pass
0	110	5179.995165	5150~5250	Pass
-10	110	5179.995685	5150~5250	Pass
-20	110	5179.993448	5150~5250	Pass

Operating Frequency: 5180 MHz				
Environment Temperature (°C)	Voltage (V)	Measured Frequency (MHz)	Limit Range	Test Result
20	99	5179.994658	5150~5250	Pass
	110	5179.998182	5150~5250	Pass
	121	5180.006635	5150~5250	Pass



CH Mid

Operating Frequency: 5220 MHz				
Environment Temperature (°C)	Voltage (V)	Measured Frequency (MHz)	Limit Range	Test Result
50	110	5220.010866	5150~5250	Pass
40	110	5219.993241	5150~5250	Pass
30	110	5220.001070	5150~5250	Pass
20	110	5219.999735	5150~5250	Pass
10	110	5220.001893	5150~5250	Pass
0	110	5220.008415	5150~5250	Pass
-10	110	5219.998436	5150~5250	Pass
-20	110	5219.997810	5150~5250	Pass

Operating Frequency: 5220 MHz				
Environment Temperature (°C)	Voltage (V)	Measured Frequency (MHz)	Limit Range	Test Result
20	99	5219.99087	5150~5250	Pass
	110	5219.998905	5150~5250	Pass
	121	5220.002749	5150~5250	Pass



CH High

Operating Frequency: 5240 MHz				
Environment Temperature (°C)	Voltage (V)	Measured Frequency (MHz)	Limit Range	Test Result
50	110	5240.008386	5150~5250	Pass
40	110	5239.995716	5150~5250	Pass
30	110	5240.009717	5150~5250	Pass
20	110	5240.006968	5150~5250	Pass
10	110	5240.003625	5150~5250	Pass
0	110	5239.992488	5150~5250	Pass
-10	110	5240.000500	5150~5250	Pass
-20	110	5239.991731	5150~5250	Pass

Operating Frequency: 5240 MHz				
Environment Temperature (°C)	Voltage (V)	Measured Frequency (MHz)	Limit Range	Test Result
20	99	5240.007814	5150~5250	Pass
	110	5240.009125	5150~5250	Pass
	121	5240.0034	5150~5250	Pass



IEEE 802.11n HT 20 mode / 5180 ~ 5240 MHz / Chain 1:

CH Low

Operating Frequency: 5180 MHz				
Environment Temperature (°C)	Voltage (V)	Measured Frequency (MHz)	Limit Range	Test Result
50	110	5179.997123	5150~5250	Pass
40	110	5179.992562	5150~5250	Pass
30	110	5179.998352	5150~5250	Pass
20	110	5179.996123	5150~5250	Pass
10	110	5180.004123	5150~5250	Pass
0	110	5179.995435	5150~5250	Pass
-10	110	5180.005316	5150~5250	Pass
-20	110	5179.996452	5150~5250	Pass

Operating Frequency: 5180 MHz				
Environment Temperature (°C)	Voltage (V)	Measured Frequency (MHz)	Limit Range	Test Result
20	93.5	5179.998523	5150~5250	Pass
	110	5180.001514	5150~5250	Pass
	126.5	5179.992576	5150~5250	Pass



CH Mid

Operating Frequency: 5220 MHz				
Environment Temperature (°C)	Voltage (V)	Measured Frequency (MHz)	Limit Range	Test Result
50	110	5219.992820	5150~5250	Pass
40	110	5219.998931	5150~5250	Pass
30	110	5220.007317	5150~5250	Pass
20	110	5220.002140	5150~5250	Pass
10	110	5219.999697	5150~5250	Pass
0	110	5220.000899	5150~5250	Pass
-10	110	5220.004035	5150~5250	Pass
-20	110	5220.005721	5150~5250	Pass

Operating Frequency: 5220 MHz				
Environment Temperature (°C)	Voltage (V)	Measured Frequency (MHz)	Limit Range	Test Result
20	93.5	5219.993042	5150~5250	Pass
	110	5220.008815	5150~5250	Pass
	126.5	5220.008458	5150~5250	Pass



CH High

Operating Frequency: 5240 MHz				
Environment Temperature (°C)	Voltage (V)	Measured Frequency (MHz)	Limit Range	Test Result
50	110	5240.010402	5150~5250	Pass
40	110	5239.990476	5150~5250	Pass
30	110	5239.991534	5150~5250	Pass
20	110	5240.004130	5150~5250	Pass
10	110	5240.005222	5150~5250	Pass
0	110	5240.002039	5150~5250	Pass
-10	110	5240.005395	5150~5250	Pass
-20	110	5240.001207	5150~5250	Pass

Operating Frequency: 5240 MHz				
Environment Temperature (°C)	Voltage (V)	Measured Frequency (MHz)	Limit Range	Test Result
20	93.5	5239.994797	5150~5250	Pass
	110	5240.000424	5150~5250	Pass
	126.5	5239.991529	5150~5250	Pass



IEEE 802.11n HT 40 mode / 5190 ~ 5230 MHz / Chain 0:

CH Low

Operating Frequency: 5190 MHz				
Environment Temperature (°C)	Voltage (V)	Measured Frequency (MHz)	Limit Range	Test Result
50	110	5189.998623	5150~5250	Pass
40	110	5190.008651	5150~5250	Pass
30	110	5189.998653	5150~5250	Pass
20	110	5189.996550	5150~5250	Pass
10	110	5190.009874	5150~5250	Pass
0	110	5189.994412	5150~5250	Pass
-10	110	5189.993571	5150~5250	Pass
-20	110	5190.000322	5150~5250	Pass

Operating Frequency: 5190 MHz				
Environment Temperature (°C)	Voltage (V)	Measured Frequency (MHz)	Limit Range	Test Result
20	93.5	5189.999652	5150~5250	Pass
	110	5190.003354	5150~5250	Pass
	126.5	5190.001655	5150~5250	Pass



CH High

Operating Frequency: 5230 MHz				
Environment Temperature (°C)	Voltage (V)	Measured Frequency (MHz)	Limit Range	Test Result
50	110	5229.994315	5150~5250	Pass
40	110	5230.000771	5150~5250	Pass
30	110	5229.993053	5150~5250	Pass
20	110	5230.010829	5150~5250	Pass
10	110	5229.999229	5150~5250	Pass
0	110	5230.007567	5150~5250	Pass
-10	110	5229.999061	5150~5250	Pass
-20	110	5230.004931	5150~5250	Pass

Operating Frequency: 5230 MHz				
Environment Temperature (°C)	Voltage (V)	Measured Frequency (MHz)	Limit Range	Test Result
20	93.5	5230.003475	5150~5250	Pass
	110	5230.009477	5150~5250	Pass
	126.5	5230.008409	5150~5250	Pass



IEEE 802.11n HT 40 mode / 5190 ~ 5230 MHz / Chain 1:

CH Low

Operating Frequency: 5190 MHz				
Environment Temperature (°C)	Voltage (V)	Measured Frequency (MHz)	Limit Range	Test Result
50	110	5189.998244	5150~5250	Pass
40	110	5190.008841	5150~5250	Pass
30	110	5189.998623	5150~5250	Pass
20	110	5189.998540	5150~5250	Pass
10	110	5190.009356	5150~5250	Pass
0	110	5189.994953	5150~5250	Pass
-10	110	5189.992560	5150~5250	Pass
-20	110	5190.000354	5150~5250	Pass

Operating Frequency: 5190 MHz				
Environment Temperature (°C)	Voltage (V)	Measured Frequency (MHz)	Limit Range	Test Result
20	93.5	5189.999574	5150~5250	Pass
	110	5190.00663	5150~5250	Pass
	126.5	5190.001547	5150~5250	Pass



CH High

Operating Frequency: 5230 MHz				
Environment Temperature (°C)	Voltage (V)	Measured Frequency (MHz)	Limit Range	Test Result
50	110	5229.998696	5150~5250	Pass
40	110	5229.990619	5150~5250	Pass
30	110	5229.995633	5150~5250	Pass
20	110	5230.009877	5150~5250	Pass
10	110	5230.003599	5150~5250	Pass
0	110	5230.004625	5150~5250	Pass
-10	110	5230.000746	5150~5250	Pass
-20	110	5230.003812	5150~5250	Pass

Operating Frequency: 5230 MHz				
Environment Temperature (°C)	Voltage (V)	Measured Frequency (MHz)	Limit Range	Test Result
20	93.5	5229.998681	5150~5250	Pass
	110	5230.00372	5150~5250	Pass
	126.5	5230.002891	5150~5250	Pass



IEEE 802.11ac VHT80 Mode / Chain 0:

CH Mid

Operating Frequency: 5210 MHz				
Environment Temperature (°C)	Voltage (V)	Measured Frequency (MHz)	Limit Range	Test Result
50	110	5209.998656	5150~5250	Pass
40	110	5210.008632	5150~5250	Pass
30	110	5209.998621	5150~5250	Pass
20	110	5209.996533	5150~5250	Pass
10	110	5210.009846	5150~5250	Pass
0	110	5209.994276	5150~5250	Pass
-10	110	5209.993725	5150~5250	Pass
-20	110	5210.000322	5150~5250	Pass

Operating Frequency: 5210 MHz				
Environment Temperature (°C)	Voltage (V)	Measured Frequency (MHz)	Limit Range	Test Result
20	99	5209.999657	5150~5250	Pass
	110	5210.003717	5150~5250	Pass
	121	5210.001154	5150~5250	Pass



IEEE 802.11ac VHT80 Mode / Chain 1:

CH Mid

Operating Frequency: 5210 MHz				
Environment Temperature (°C)	Voltage (V)	Measured Frequency (MHz)	Limit Range	Test Result
50	110	5210.008632	5150~5250	Pass
40	110	5210.008637	5150~5250	Pass
30	110	5209.998627	5150~5250	Pass
20	110	5209.996533	5150~5250	Pass
10	110	5209.996528	5150~5250	Pass
0	110	5209.994272	5150~5250	Pass
-10	110	5210.000236	5150~5250	Pass
-20	110	5209.994275	5150~5250	Pass

Operating Frequency: 5210 MHz				
Environment Temperature (°C)	Voltage (V)	Measured Frequency (MHz)	Limit Range	Test Result
20	99	5209.999145	5150~5250	Pass
	110	5210.001346	5150~5250	Pass
	121	5210.002452	5150~5250	Pass



APPENDIX I PHOTOGRAPHS OF TEST SETUP

Conducted Emission Set Up Photo

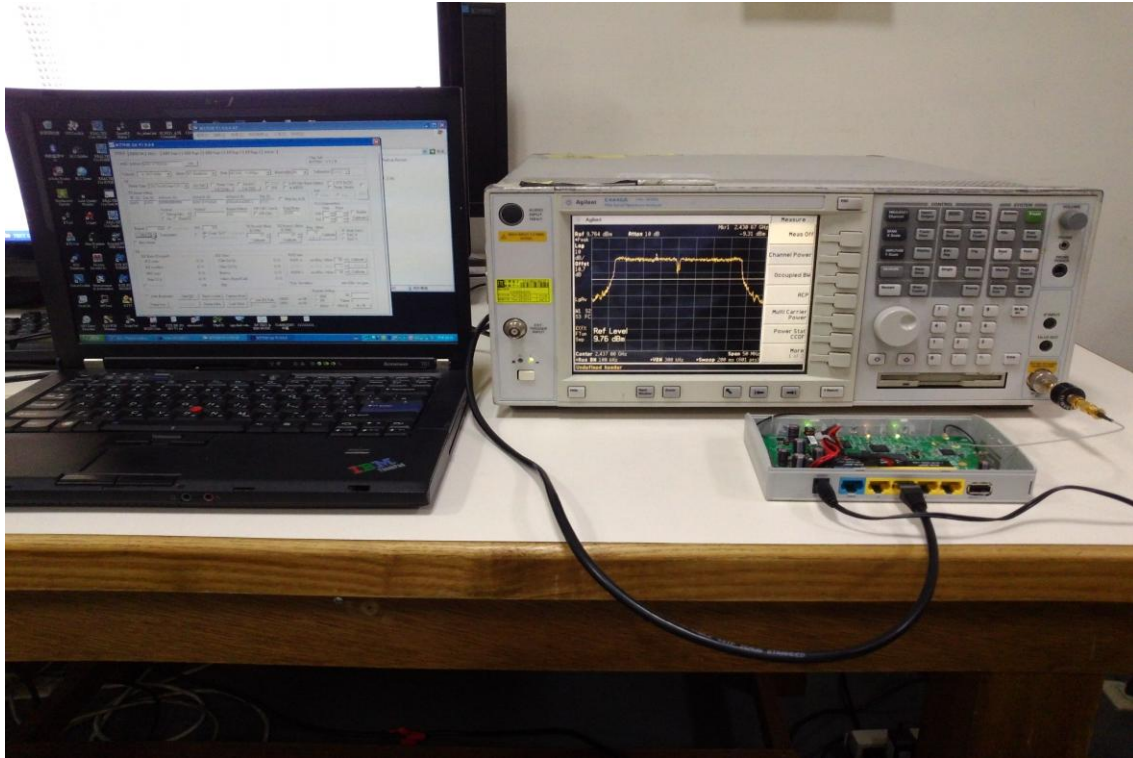



Radiated Emission Set up Photos

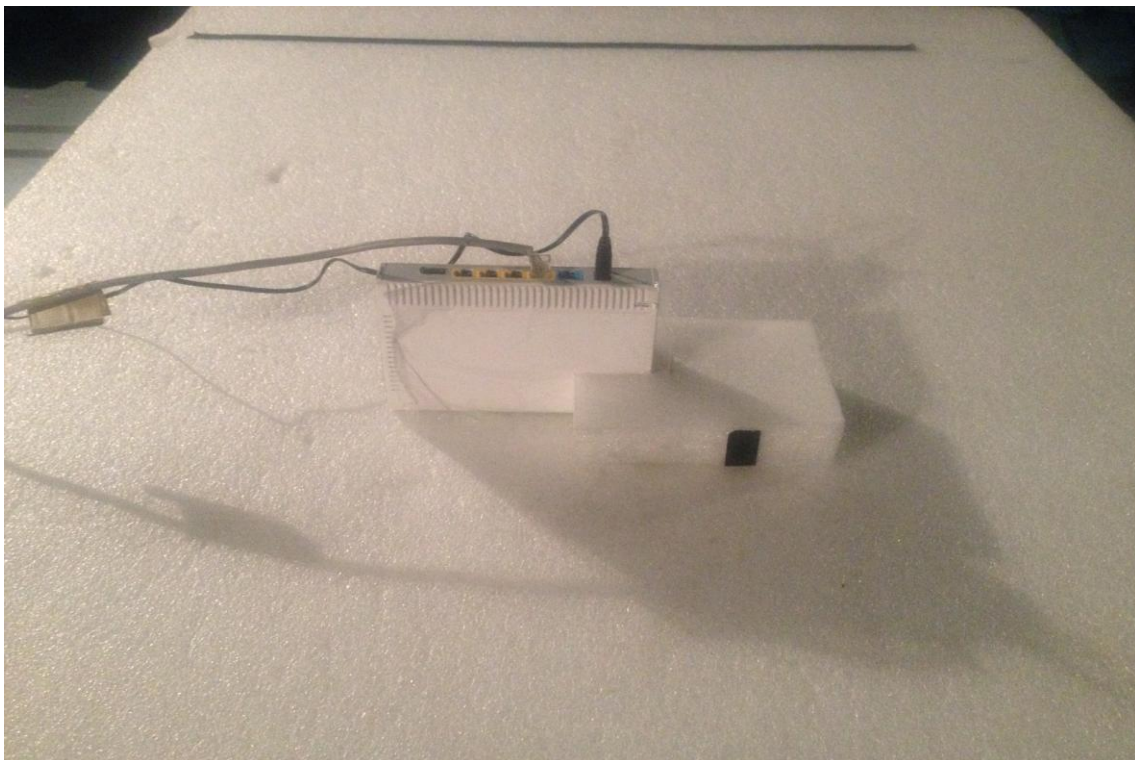
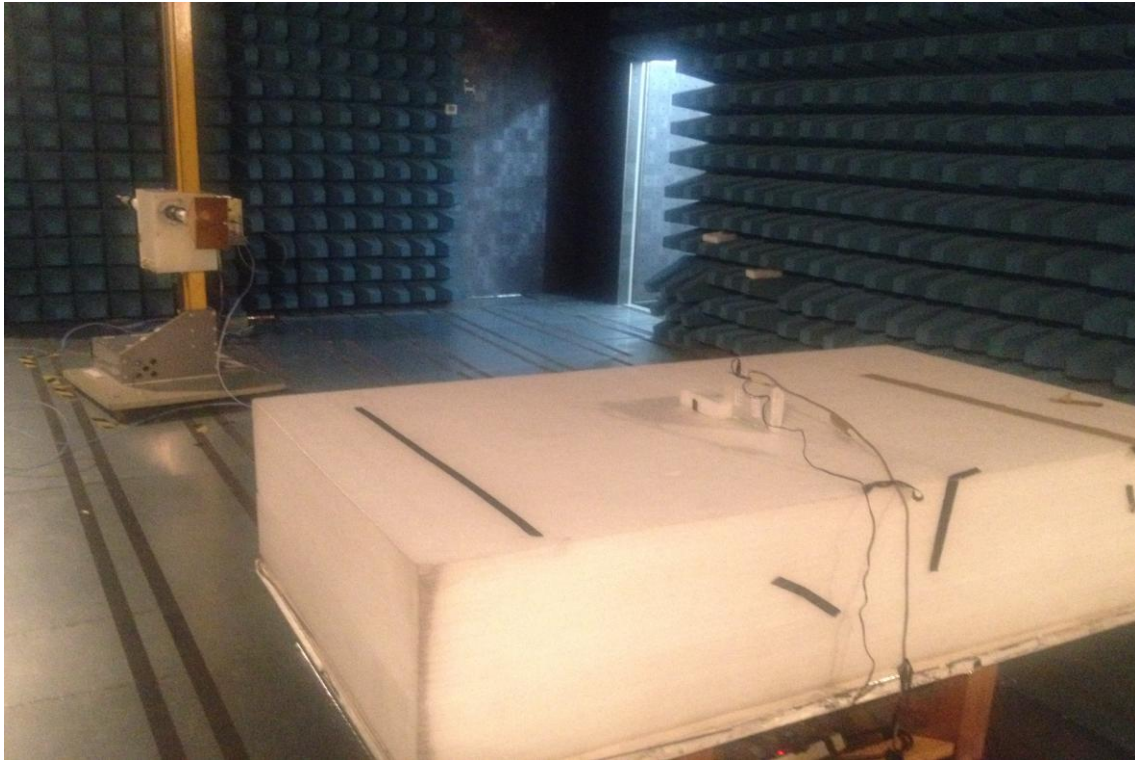



Powerline Conducted Emissions Setup Photos

