



**FCC ID: NDD9562040507**  
Issued on July 14, 2005

Report No.: FR561705

# FCC TEST REPORT

**CATEGORY** : Mobile  
**PRODUCT NAME** : Wireless Broadband Router  
**FCC ID.** : NDD9562040507  
**FILING TYPE** : Certification  
**MODEL (BRAND) NAME** : BR-6204Wg, BR-6304Wg, EW-7209APg (EDIMAX),  
GR-F04P, GR-F04PV, GAP-E09g (GLP)  
**APPLICANT** : **EDIMAX TECHNOLOGY CO., LTD.**  
No. 3, Wu Chuan 3rd Road, Wu-Ku Industrial Park, Taipei  
Hsien, Taiwan, R.O.C.  
**MANUFACTURER** : **EDIMAX TECHNOLOGY CO., LTD.**  
No. 3, Wu Chuan 3rd Road, Wu-Ku Industrial Park, Taipei  
Hsien, Taiwan, R.O.C.  
**ISSUED BY** : **SPORTON INTERNATIONAL INC.**  
6F, No. 106, Sec. 1, Hsin Tai Wu Rd., His Chih, Taipei Hsien,  
Taiwan, R.O.C.

## Statements:

The test result in this report refers exclusively to the presented test model / sample.

Without written approval of SPORTON International Inc., the test report shall not be reproduced except in full.

Certificate or Test Report could not be used by the applicant to claim the product endorsement by CNLA and any agency of U.S. government.

The test equipment used to perform the test is calibrated and traceable to NML/ROC or NIST/USA.



1190  
ILAC MRA

**SPORTON International Inc.**

TEL : 886-2-2696-2468

FAX : 886-2-2696-2255



## Table of Contents

<b>HISTORY OF THIS TEST REPORT .....</b>	<b>II</b>
<b>CERTIFICATE OF COMPLIANCE.....</b>	<b>III</b>
<b>1. GENERAL DESCRIPTION OF EQUIPMENT UNDER TEST.....</b>	<b>1</b>
1.1. Applicant .....	1
1.2. Manufacturer .....	1
1.3. Basic Description of Equipment under Test.....	1
1.4. Features of Equipment under Test .....	1
1.5. Antenna Description.....	2
1.6. Table for Carrier Frequencies .....	2
1.7. Multiple List .....	3
<b>2. TEST CONFIGURATION OF THE EQUIPMENT UNDER TEST .....</b>	<b>4</b>
2.1. Connection Diagram of Test System .....	4
2.2. The Test Mode Description .....	4
2.3. Description of Test Supporting Units .....	5
<b>3. GENERAL INFORMATION OF TEST .....</b>	<b>6</b>
3.1. Test Facility .....	6
3.2. Standards for Methods of Measurement.....	6
3.3. DoC Statement .....	6
3.4. Frequency Range Investigated .....	6
3.5. Test Distance .....	6
3.6. Test Software.....	6
<b>4. LIST OF MEASUREMENTS .....</b>	<b>8</b>
4.1. Summary of the Test Results.....	8
<b>5. TEST RESULT .....</b>	<b>9</b>
5.1. Test of 6dB Spectrum Bandwidth .....	9
5.2. Test of Maximum Peak Conducted Output Power .....	14
5.3. Test of Peak Power Spectral Density .....	16
5.4. Test of Band Edges Emission.....	21
5.5. Test of AC Power Line Conducted Emission .....	27
5.6. Test of Spurious Radiated Emission.....	32
5.7. Antenna Requirements .....	51
5.8. RF Exposure .....	52
<b>6. LIST OF MEASURING EQUIPMENTS USED.....</b>	<b>54</b>
<b>7. COMPANY PROFILE.....</b>	<b>57</b>
7.1. Certificate of Accreditation .....	57
7.2. Test Location .....	57
<b>8. CNLA CERTIFICATE OF ACCREDITATION.....</b>	<b>58</b>
<b>APPENDIX A. PHOTOGRAPHS OF EUT .....</b>	<b>A1 ~ A9</b>





# CERTIFICATE OF COMPLIANCE

with

## 47 CFR FCC Part 15 Subpart C

**PRODUCT NAME** : Wireless Broadband Router  
**MODEL (BRAND) NAME** : BR-6204Wg, BR-6304Wg, EW-7209APg (EDIMAX),  
GR-F04P, GR-F04PV, GAP-E09g (GLP)  
**APPLICANT** : **EDIMAX TECHNOLOGY CO., LTD.**  
No. 3, Wu Chuan 3rd Road, Wu-Ku Industrial Park, Taipei  
Hsien, Taiwan, R.O.C.  
**MANUFACTURER** : **EDIMAX TECHNOLOGY CO., LTD.**  
No. 3, Wu Chuan 3rd Road, Wu-Ku Industrial Park, Taipei  
Hsien, Taiwan, R.O.C.

I **HEREBY** CERTIFY THAT:

The measurements shown in this test report were made in accordance with the procedures given in ANSI C63.4-2003 and all test are performed according to 47 CFR FCC Part 15 Subpart C. Testing was carried out on July 07, 2005 at SPORTON International Inc. LAB.



Wayne Hsu / Supervisor  
Sporton International Inc.



## 1. General Description of Equipment under Test

### 1.1. Applicant

**EDIMAX TECHNOLOGY CO., LTD.**

No. 3, Wu Chuan 3rd Road, Wu-Ku Industrial Park, Taipei Hsien, Taiwan, R.O.C.

### 1.2. Manufacturer

**EDIMAX TECHNOLOGY CO., LTD.**

No. 3, Wu Chuan 3rd Road, Wu-Ku Industrial Park, Taipei Hsien, Taiwan, R.O.C.

### 1.3. Basic Description of Equipment under Test

This product is a Wireless Broadband Router with 802.11b/g wireless solution. The technical data has been listed on section " Features of Equipment under Test ".

### 1.4. Features of Equipment under Test

Items	Description
Type of Modulation	DSSS (CCK / DQPSK / DBPSK) OFDM (16QAM / 64QAM / DQPSK / DBPSK )
Number of Channels	11
Frequency Band	2400.0 MHz ~ 2483.5 MHz
Carrier Frequency Range	2412.0 MHz ~ 2462.0 MHz
Carrier Frequency	See section 1.6 for details
Data Rate	1, 2, 5.5, 11 Mbps - DSSS 6, 12, 18, 24, 36, 48, 54 Mbps - OFDM
Channel Bandwidth	16 MHz
Max. Conducted Output Power	DSSS : 18.34 dBm OFDM : 15.54dBm
Antenna Type	See section 1.5 for details
Communication Type	Half-Duplex
Testing Duty Cycle	100.00%
Power Rating (DC/AC, Voltage)	12VDC from adapter
Test Power Source	110.00V AC
Temperature Range (Operating)	0 ~ 50 °C



### 1.5. Antenna Description

No.	Antenna Type	Gain (dBi)
1	Dipole Antenna	5.00

### 1.6. Table for Carrier Frequencies

Channel	Frequency	Channel	Frequency	Channel	Frequency	Channel	Frequency
01	2412 MHz	05	2432 MHz	09	2452 MHz	-	-
02	2417 MHz	06	2437 MHz	10	2457 MHz	-	-
03	2422 MHz	07	2442 MHz	11	2462 MHz	-	-
04	2427 MHz	08	2447 MHz	-	-	-	-



## 1.7. Multiple List

### 6204Wg/6304Wg/7209APg

	Brand Name	Edimax Model	Customer Model Name
1	Edimax	6204Wg	BR-6204Wg
		6304Wg	BR-6304wg
		7209APg	EW-7209APg
2	GLP	6204Wg	GR-F04P
		6304Wg	GR-F04PV
		7209APg	GAP-E09g
3	Sandberg A/S Denmark	6204Wg	130-99
4	Sitecom	6204Wg	WL-527
5	2L/Tulip (Conceptronic)	6204Wg	C54BRS4
6	hama	6204Wg	62785
7	Asbis(Canyon)	6204Wg	CN-WF514
8	Planet	6204Wg	WRT-414
9	Planet	7209APg	WAP-4032
10	Longshine	6204Wg	LCS-WR5-2114
11	IC Intracom	6204Wg	521666
12	Startech	6204Wg	HUBS-BR455GWDC
13	Mustek	6204Wg	BR-6204Wg
14	MICROTEK ITALIA SPA	6204Wg	MEG323
15	American Satellite	6204Wg	RS-100R

## 2. Test Configuration of the Equipment under Test

### 2.1. Connection Diagram of Test System

<Radiation>

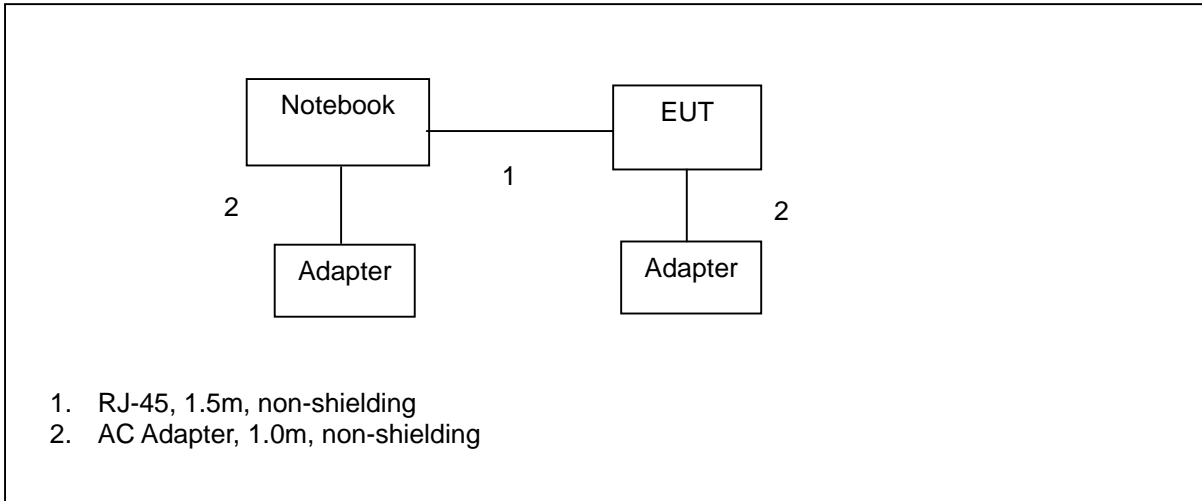

<Conduction>

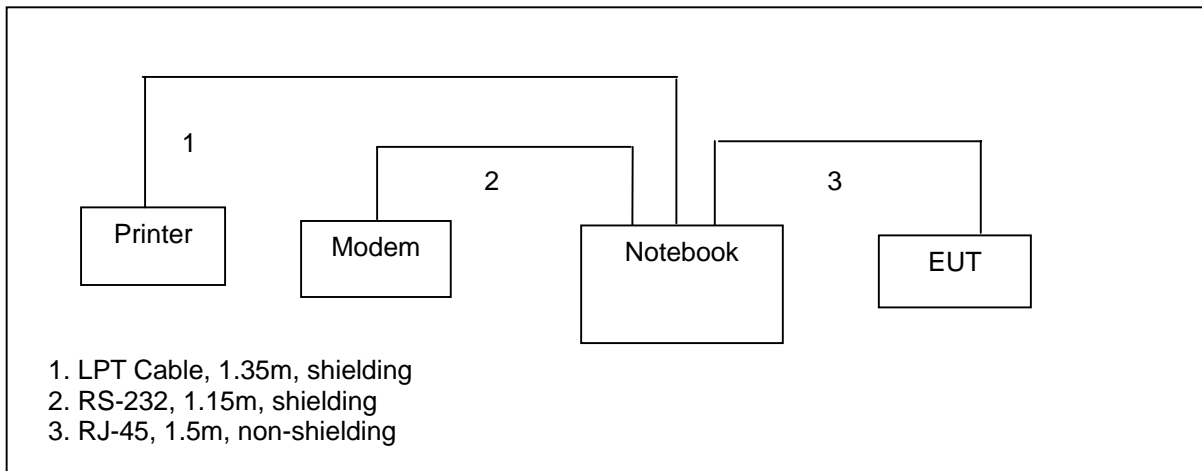

### 2.2. The Test Mode Description

1. For DSSS modulation, CCK (11 Mbps) is the worst case on all test items.
2. For OFDM modulation, BPSK (6 Mbps) is the worst case on all test items.
3. According to ANSI C63.4-2003: If frequency range of EUT is more than 10 MHz, we have to test the lowest, middle and highest channels of EUT.
4. Spurious emission below 1GHz is independent of channel selection and modulation types, so only channel 06 was tested.
5. For AC conduction emission, the EUT linked with Notebook wirelessly.





### 2.3. Description of Test Supporting Units

Support unit	Brand	Model No.	FCC ID
Notebook	DELL	D505	DoC
Printer	EPSON	LQ-680	DoC
Modem	ACEEX	DM-1414	IFAXDM1414



### 3. General Information of Test

#### 3.1. Test Facility

**Test Site Location** : No. 52, Hwa Ya 1st Rd., Hwa Ya Technology Park, Kwei-Shan Hsiag, Tao Yuan Hsien, Taiwan, R.O.C.  
: TEL 886-3-327-3456  
: FAX 886-3-318-0055

**Test Site No** : 03CH03-HY / TH01-HY / CO04-HY

#### 3.2. Standards for Methods of Measurement

Here is the list of the standards followed in this test report.

**ANSI C63.4-2003**  
**47 CFR FCC Part 15 Subpart C**

#### 3.3. DoC Statement

This EUT is also classified as a device of computer peripheral Class B which DoC has to be followed. It has been verified according to the rule of 47 CFR part 15 Subpart B, and found that all the requirements has been fulfilled.

#### 3.4. Frequency Range Investigated

Radiated emission test: from 9 kHz to 10th carrier harmonic

#### 3.5. Test Distance

The test distance of radiated emission (9kHz~1GHz) test from antenna to EUT is 3 M.

The test distance of radiated emission (1GHz~10th carrier harmonic) test from antenna to EUT is 3 M.

#### 3.6. Test Software

An executive program, EMITEST.EXE under WIN XP, which generates a complete line of continuously repeating "H" pattern was used as the test software.

At the same time, the following programs were executed:

- Executed one self-test program to keep sending signals.

Conduction: Executed "Ping.exe " was executed to link with AP to receive and transmit data wirelessly.

Radiation: The EUT was transmitting continuously.



**Power Parameter Table**

Software Version : MP\_TEST  
Power Set CH01 / DSSS : 11  
Power Set CH06 / DSSS : 11  
Power Set CH11 / DSSS : 11  
Power Set Ch01 / OFDM : 15  
Power Set Ch06 / OFDM : 15  
Power Set Ch11 / OFDM : 15



## 4. List of Measurements

### 4.1. Summary of the Test Results

Applied Standard: 47 CFR FCC Part 15 Subpart C			
Paragraph	FCC Section	Description of Test	Result
5.1	15.247(a)(2)	6dB Spectrum Bandwidth	Pass
5.2	15.247(b)(3)	Maximum Peak Conducted Output Power	Pass
5.3	15.247(e)	Peak Power Spectral Density	Pass
5.4	15.247(d)	Band Edges Emission	Pass
5.5	15.207	AC Power Line Conducted Emission	Pass
5.6	15.247(d)	Spurious Radiated Emission	Pass
5.7	15.203/15.247(b)/(c)	Antenna Requirement	Pass
5.8	2.1091	Maximum Permissible Exposure	Pass

## 5. Test Result

### 5.1. Test of 6dB Spectrum Bandwidth

#### 5.1.1. Applicable Standard

Section 15.247(a)(2): For digital modulation systems, the minimum 6 dB bandwidth shall be at least 500 kHz.

#### 5.1.2. Measuring Instruments

Item 21 of the table on section 6.

#### 5.1.3. Description of Major Test Instruments Setting

- Spectrum Analyzer : R&S FSP30
- Attenuation : Auto
- Center Frequency : 2412 MHz / 2437 MHz / 2462 MHz
- Span Frequency : > 6dB Bandwidth
- RB : 100 kHz
- VB : 100 kHz
- Detector : Peak
- Trace : Max Hold
- Sweep Time : Auto

#### 5.1.4. Test Procedures

1. The transmitter output was connected to the spectrum analyzer through an attenuator.
2. Set RBW of spectrum analyzer to 100KHz and VBW to 100KHz. Trace to Max hold and Detector PK.
3. The bandwidth is the spectrum width with level higher than 6dB below the peak level.
4. Repeat above 1~3 points for the middle and highest channel of the EUT.

#### 5.1.5. Test Setup Layout

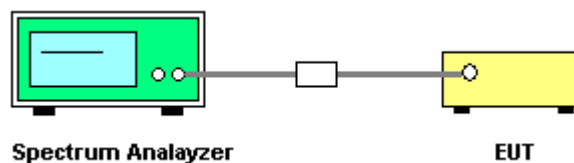

#### 5.1.6. Test Criteria

All test results complied with the requirements of 15.247(a)(2). Measurement Uncertainty is  $1 \times 10^{-5}$ .



5.1.7. Test Result

- Temperature: 25°C
- Relative Humidity: 60%
- Duty Cycle of the Equipment During the Test: 100.00%
- Test Engineer: Eason Lu

Modulation Type	Channel No.	Frequency (MHz)	6dB Bandwidth	Min. Limit
DSSS	01	2412 MHz	8.80	0.5
DSSS	06	2437 MHz	9.24	0.5
DSSS	11	2462 MHz	9.16	0.5
OFDM	01	2412 MHz	16.08	0.5
OFDM	06	2437 MHz	15.84	0.5
OFDM	11	2462 MHz	15.80	0.5

Modulation Type: DSSS (Channel 01) :

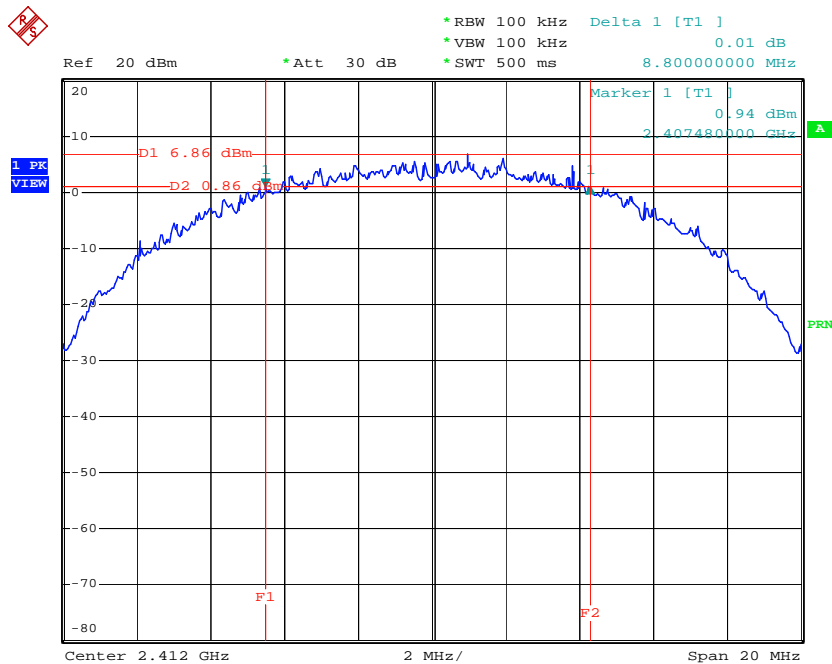

Date: 21.JUN.2005 11:55:44



Modulation Type: DSSS (Channel 06) :

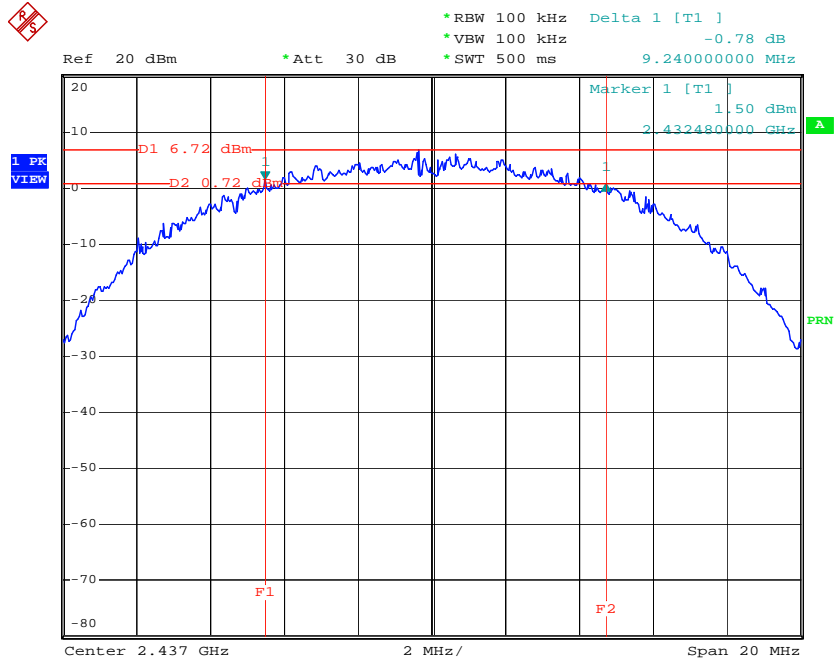

Date: 21.JUN.2005 11:48:15

Modulation Type: DSSS (Channel 11) :

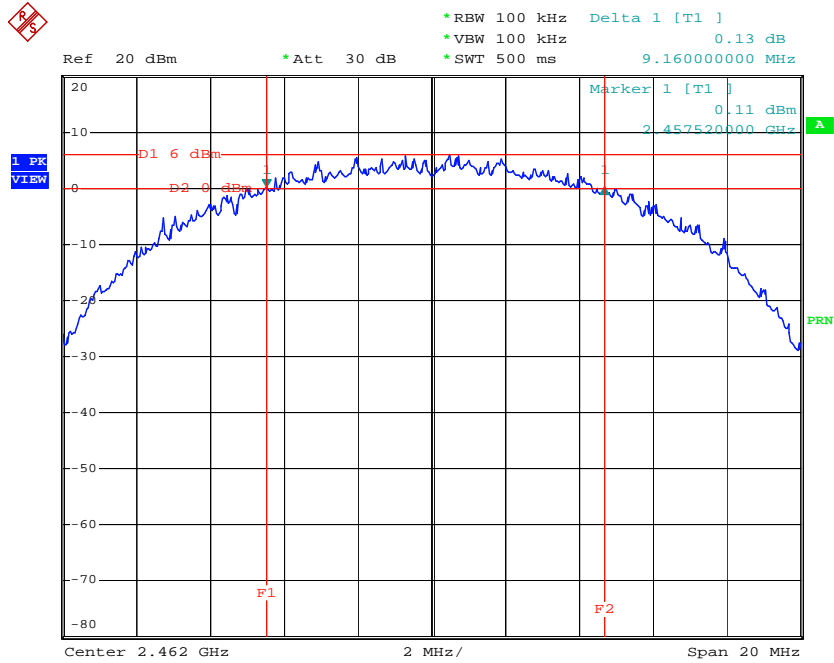

Date: 21.JUN.2005 11:49:35



Modulation Type: OFDM (Channel 01) :

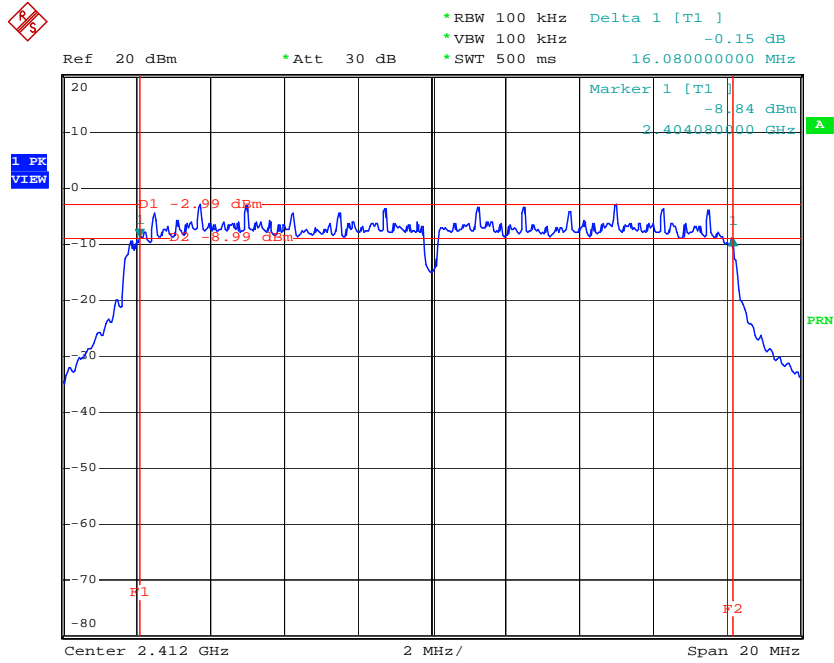

Date: 21.JUN.2005 12:08:49

Modulation Type: OFDM (Channel 06) :

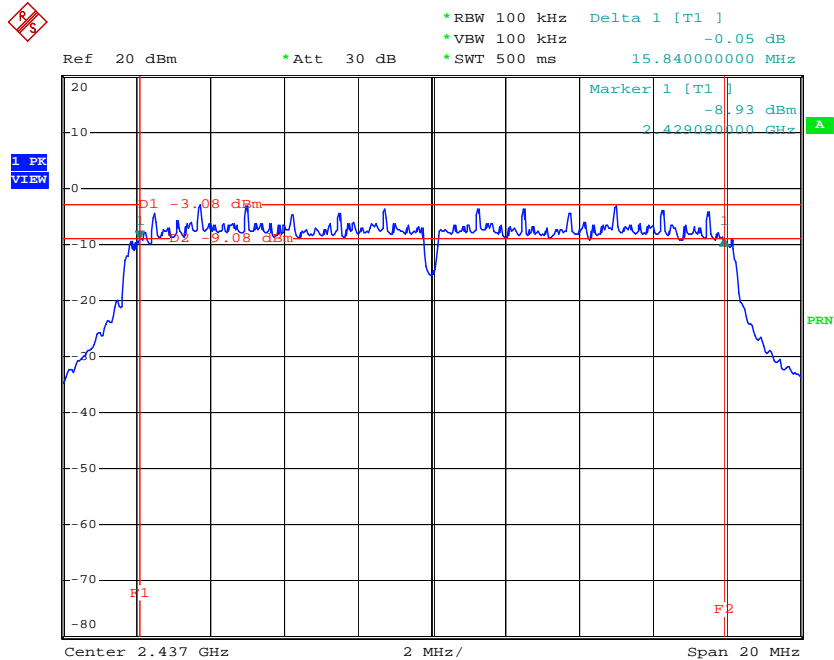

Date: 21.JUN.2005 12:15:45





Modulation Type: OFDM (Channel 11) :

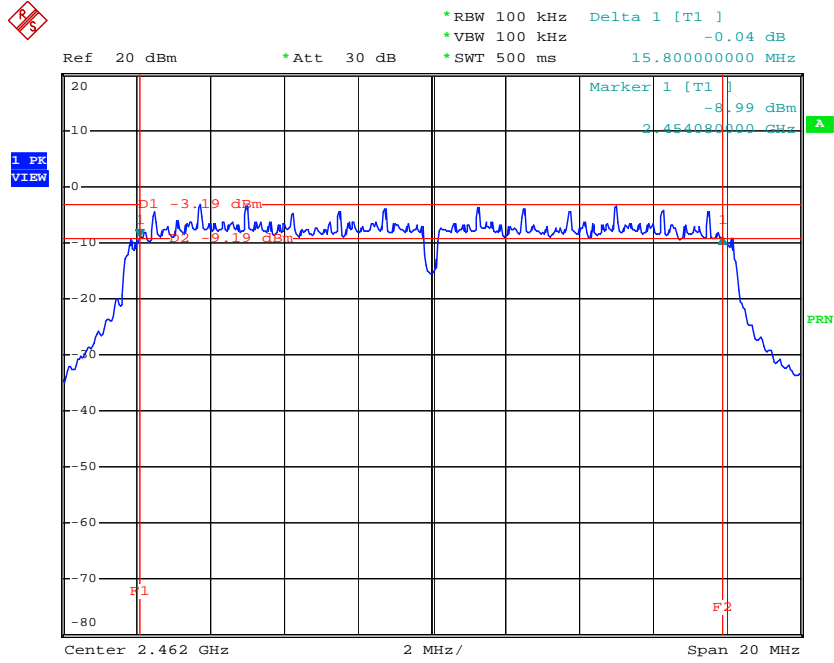

Date: 21.JUN.2005 12:17:18

## 5.2. Test of Maximum Peak Conducted Output Power

### 5.2.1. Applicable Standard

Section 15.247(b)(3): The maximum peak output power shall not exceed 1 watt (30dBm). Except as shown below, if transmitting antennas of directional gain greater than 6 dBi are used the peak output power from the intentional radiator shall be reduced below the above stated values by the amount in dB that the directional gain of the antenna exceeds 6 dBi.

### 5.2.2. Measuring Instruments

Item 22, 24 of the table on section 6.

### 5.2.3. Test Procedures and Test Instruments Setting

1. The transmitter output was connected to the peak power meter through an attenuator.
2. Repeated point 1 for the middle and highest channel of the EUT.

### 5.2.4. Test Setup Layout

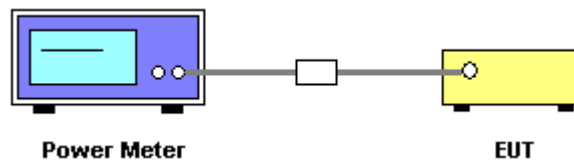

### 5.2.5. Test Criteria

All test results complied with the requirements of 15.247(b)(3). Measurement Uncertainty is 1.5dB.



5.2.6. Test Result of Conducted Power

- Temperature: 25°C
- Relative Humidity: 60%
- Duty Cycle of the Equipment During the Test: 100.00%
- Test Engineer: Eason Lu

Modulation Type	Channel No.	Frequency (MHz)	Output Power (dBm)	Limits (dBm)
DSSS	01	2412 MHz	18.18	30
DSSS	06	2437 MHz	18.34	30
DSSS	11	2462 MHz	18.26	30
OFDM	01	2412 MHz	15.27	30
OFDM	06	2437 MHz	15.54	30
OFDM	11	2462 MHz	15.46	30

### 5.3. Test of Peak Power Spectral Density

#### 5.3.1. Applicable Standard

Section 15.247(e): For digital modulation systems, the peak power spectral density conducted from the intentional radiator to the antenna shall not be greater than 8 dBm in any 3 kHz band during any time interval of continuous transmission.

#### 5.3.2. Measuring Instruments

Item 21 of the table on section 6.

#### 5.3.3. Description of Major Test Instruments Setting

- Spectrum Analyzer : R&S FSP30
- Attenuation : Auto
- Center Frequency : 2412 MHz / 2437 MHz / 2462 MHz
- Span Frequency : 1.5MHz
- RB : 3 kHz
- VB : 30 kHz
- Detector : Peak
- Trace : Max Hold
- Sweep Time : 500s

#### 5.3.4. Test Procedures

1. The transmitter output is connected to the spectrum analyzer through an attenuator.
2. Set RBW of spectrum analyzer to 3kHz and VBW to 30kHz. Set Detector to Peak, Trace to Max Hold.
3. Mark the frequency with maximum peak power as the center of the display of the spectrum.
4. Set the span to 1.5MHz and the sweep time to 500s and record the maximum peak value.
5. Repeated the 1~4 for the middle and highest channel of the EUT.

#### 5.3.5. Test Setup Layout

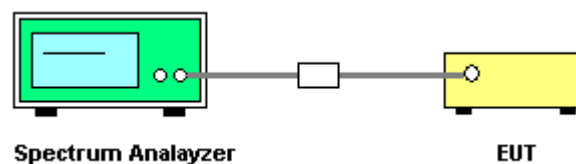

#### 5.3.6. Test Criteria

All test results complied with the requirements of 15.247(e). Measurement Uncertainty is 1.5dB.



5.3.7. Test Result

- Temperature: 25°C
- Relative Humidity: 60%
- Duty Cycle of the Equipment During the Test: 100.00%
- Test Engineer: Eason Lu

Modulation Type	Channel No.	Frequency (MHz)	Power Density (dBm)	Limits (dBm)
DSSS	01	2412 MHz	4.85	8
DSSS	06	2437 MHz	4.86	8
DSSS	11	2462 MHz	3.87	8
OFDM	01	2412 MHz	-17.07	8
OFDM	06	2437 MHz	-17.48	8
OFDM	11	2462 MHz	-17.54	8

Modulation Type: DSSS (Channel 01) :

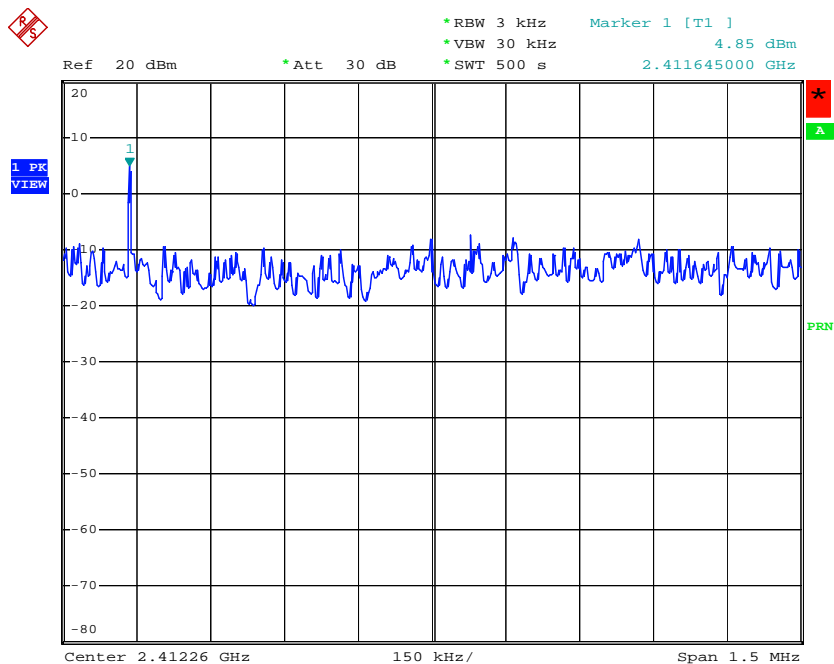

Date: 21.JUN.2005 11:58:50



Modulation Type: DSSS (Channel 06) :

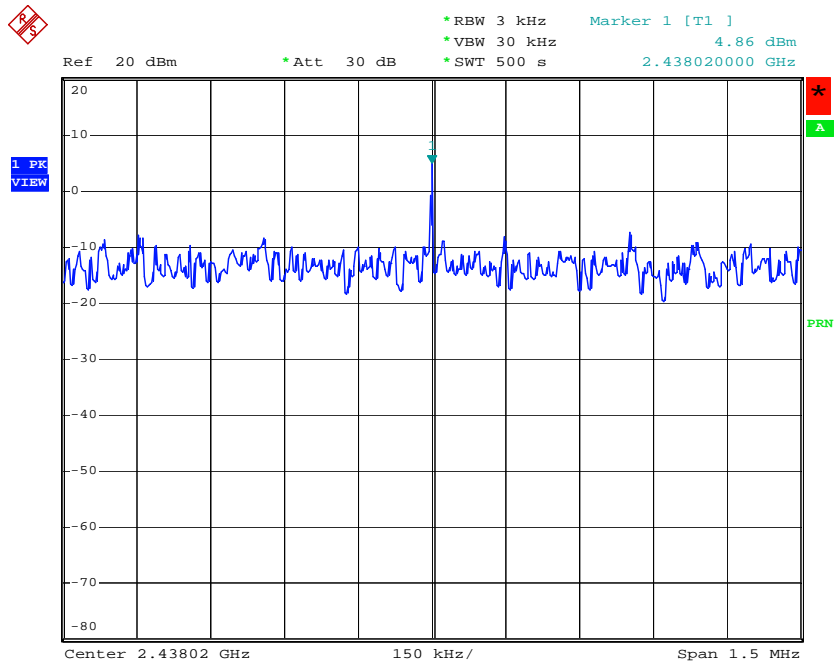

Date: 21.JUN.2005 12:01:18

Modulation Type: DSSS (Channel 11) :

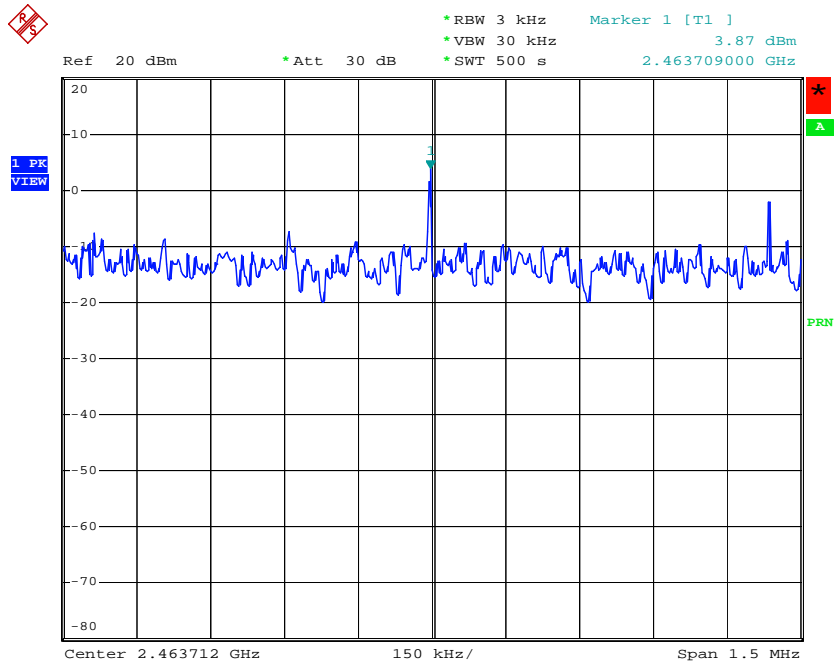

Date: 21.JUN.2005 12:03:36



Modulation Type: OFDM (Channel 01) :

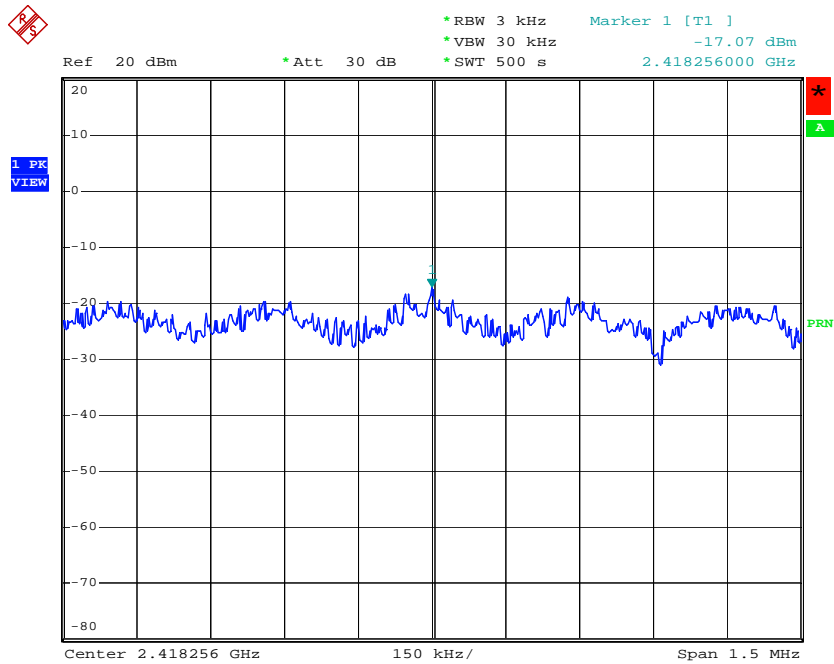

Date: 21.JUN.2005 12:11:51

Modulation Type: OFDM (Channel 06) :

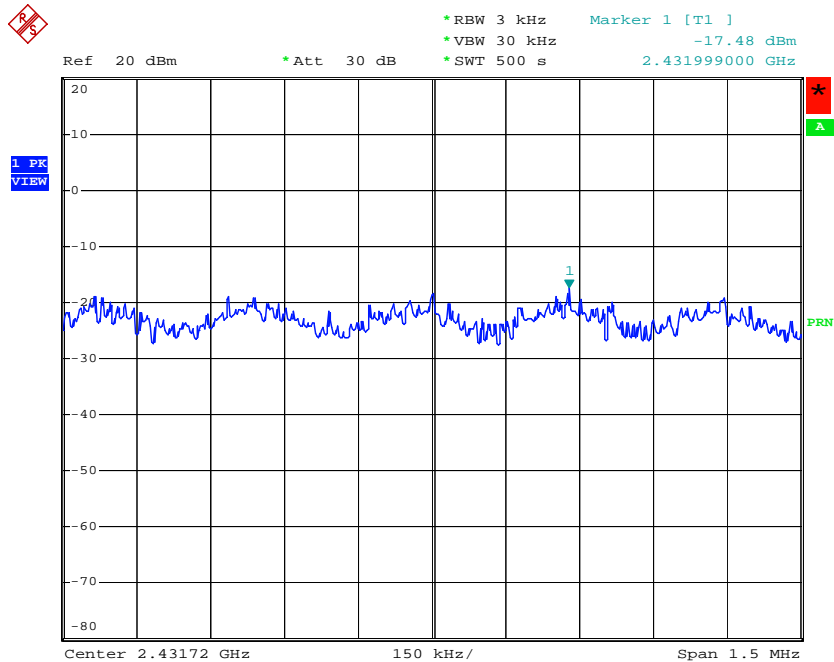

Date: 21.JUN.2005 12:14:04



Modulation Type: OFDM (Channel 11) :

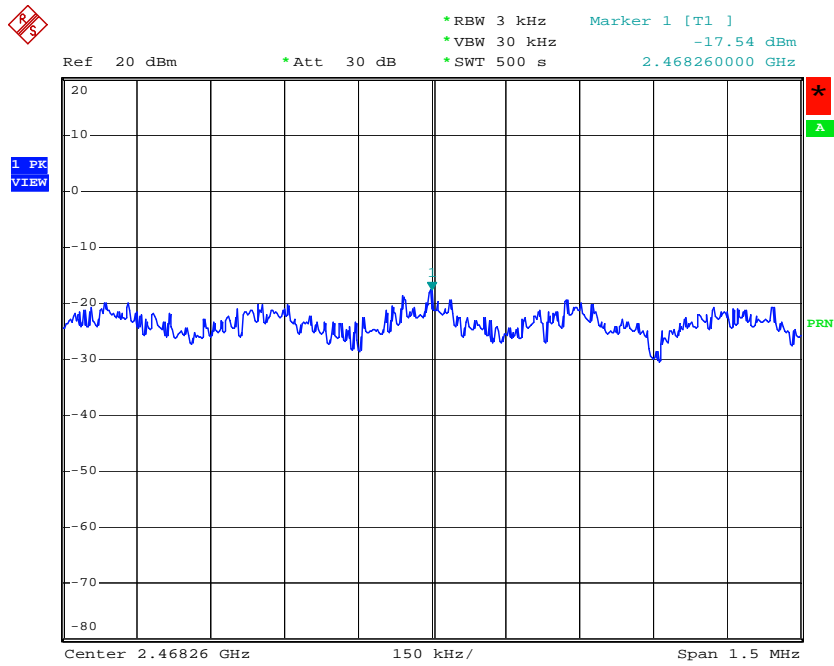

Date: 21.JUN.2005 12:21:11





## 5.4. Test of Band Edges Emission

### 5.4.1. Applicable Standard

Section 15.247(d): In any 100 kHz bandwidth outside the frequency band in which the spread spectrum or digitally modulated intentional radiator is operating, the radio frequency power that is produced by the intentional radiator shall be at least 20 dB below that in the 100 kHz bandwidth within the band that contains the highest level of the desired power, based on either an RF conducted or a radiated measurement. In addition, radiated emissions that fall in the restricted bands, as defined in Section 15.205, must also comply with the radiated emission limits specified in Section 15.209.

### 5.4.2. Measuring Instruments

Item 6~20 of the table on section 6 for radiated measurement.

Item 21 of the table on section 6 for conducted measurement.

### 5.4.3. Description of Major Test Instruments Setting

- Spectrum Analyzer : R&S FSP30 (Conducted Measurement)
  - Attenuation : Auto
  - Center Frequency : 2412 MHz / 2462 MHz
  - Span Frequency : 100MHz
  - RB : 100 kHz
  - VB : 100 kHz
  - Detector : Peak
  - Trace : Max Hold
  - Sweep Time : Auto
  
- Spectrum Analyzer : R&S FSP40 (Radiated Measurement)
  - Attenuation : Auto
  - Center Frequency : 2412 MHz / 2462 MHz
  - Span Frequency : 100MHz
  - RB : 1 MHz for PK value / 1 MHz for AV value
  - VB : 1 MHz for PK value / 10 Hz for AV value
  - Detector : Peak
  - Trace : Max Hold
  - Sweep Time : Auto

### 5.4.4. Test Procedures and Test Instruments Setting

#### Conducted Measurement

1. The transmitter is set to the lowest channel.
2. The transmitter output was connected to the spectrum analyzer via a cable and cable loss is used as the offset of the spectrum analyzer.
3. Set both RBW and VBW of spectrum analyzer to 100KHz with convenient frequency span including 100MHz bandwidth from lower band edge. Then detector set to peak and max hold this trace.

4. The lowest band edges emission was measured and recorded.
5. The transmitter set to the highest channel and repeated 2~4.

**Radiated Measurement**

1. Configure the EUT according to ANSI C63.4.-2003
2. The turntable was rotated by 360 degrees to determine the position of the highest radiation.
3. The height of the broadband receiving antenna was varied between one meter and four meters above ground to find the maximum emission field strength of both horizontal and vertical polarization.
4. For band edge emission, the antenna tower was scan (from 1 M to 4 M) and then the turn table was rotated (from 0 degree to 360 degrees) to find the maximum reading.
5. For band edge emission in restriction bands, use 10Hz VBW and 1MHz RBW for reading under AV and use 1MHz VBW and 1 MHz RBW for reading under PK.

5.4.5. Test Setup

**Radiated Method**

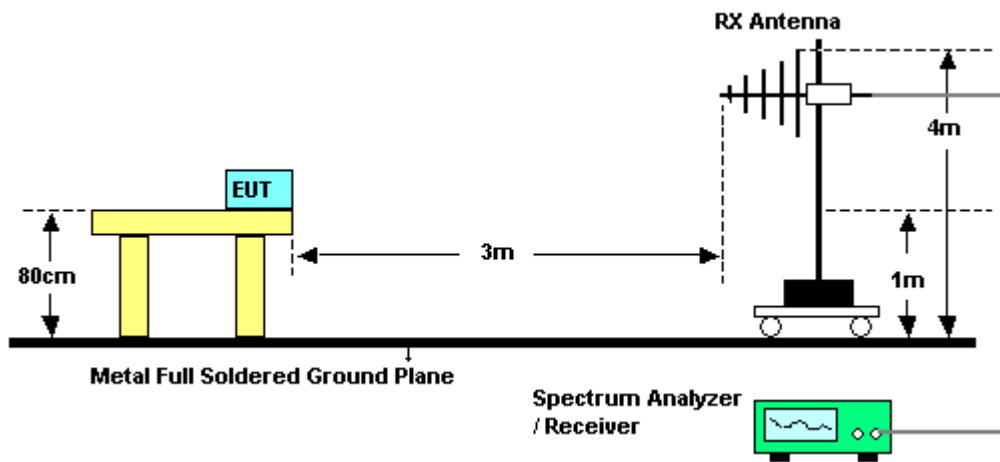

**Conducted Method**

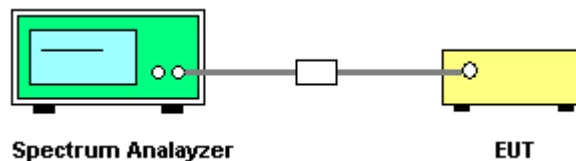

5.4.6. Test Criteria

All test results complied with the requirements of 15.247(d). Measurement Uncertainty is  $1 \times 10^{-5}$ .



5.4.7. Test Results for CH 00 / 2402 MHz

- Modulation Type: DSSS
- Temperature: 25°C
- Relative Humidity: 60%
- Duty Cycle of the Equipment During the Test: 100.00%
- Test Engineer: Eason Lu

	Freq	Level	Over Limit	Read Level	Limit Line	Factor	Cable Loss	Preamp Factor	Remark	Ant Pos	Table Pos
	MHz	dBuV/m	dB	dBuV	dBuV/m	dB	dB	dB		cm	deg
1	2371.940	57.35	-16.65	27.26	74.00	30.09	1.90	0.00	Peak	---	---
2	2371.940	48.89	-5.11	18.80	54.00	30.09	1.90	0.00	Average	---	---

5.4.8. Test Results for CH 00 / 2402 MHz

- Modulation Type: OFDM
- Temperature: 25°C
- Relative Humidity: 60%
- Duty Cycle of the Equipment During the Test: 100.00%
- Test Engineer: Eason Lu

	Freq	Level	Over Limit	Read Level	Limit Line	Factor	Cable Loss	Preamp Factor	Remark	Ant Pos	Table Pos
	MHz	dBuV/m	dB	dBuV	dBuV/m	dB	dB	dB		cm	deg
1	2389.990	58.42	-15.58	28.30	74.00	30.12	1.90	0.00	Peak	---	---
2	2389.990	45.84	-8.16	15.72	54.00	30.12	1.90	0.00	Average	---	---



5.4.9. Test Results for CH 11 / 2462 MHz

- Modulation Type: DSSS
- Temperature: 25°C
- Relative Humidity: 60%
- Duty Cycle of the Equipment During the Test: 100.00%
- Test Engineer: Eason Lu

	Freq	Level	Over Limit	Read Level	Limit Line	Factor	Cable Loss	Preamp Factor	Remark	Ant Pos	Table Pos
	MHz	dBuV/m	dB	dBuV	dBuV/m	dB	dB	dB		cm	deg
1	2488.220	61.01	-12.99	30.65	74.00	30.36	1.96	0.00	Peak	---	---
2	2488.220	51.18	-2.82	20.82	54.00	30.36	1.96	0.00	Average	---	---

5.4.10. Test Results for CH 11 / 2462 MHz

- Modulation Type: OFDM
- Temperature: 25°C
- Relative Humidity: 60%
- Duty Cycle of the Equipment During the Test: 100.00%
- Test Engineer: Eason Lu

	Freq	Level	Over Limit	Read Level	Limit Line	Factor	Cable Loss	Preamp Factor	Remark	Ant Pos	Table Pos
	MHz	dBuV/m	dB	dBuV	dBuV/m	dB	dB	dB		cm	deg
1	2483.500	64.18	-9.82	33.85	74.00	30.33	1.96	0.00	Peak	---	---
2	2483.500	49.00	-5.00	18.67	54.00	30.33	1.96	0.00	Average	---	---

**Level\*:** The max field strength in the restricted bands.



Test Result of Conducted Emission

Modulation Type: DSSS (Channel 01) :

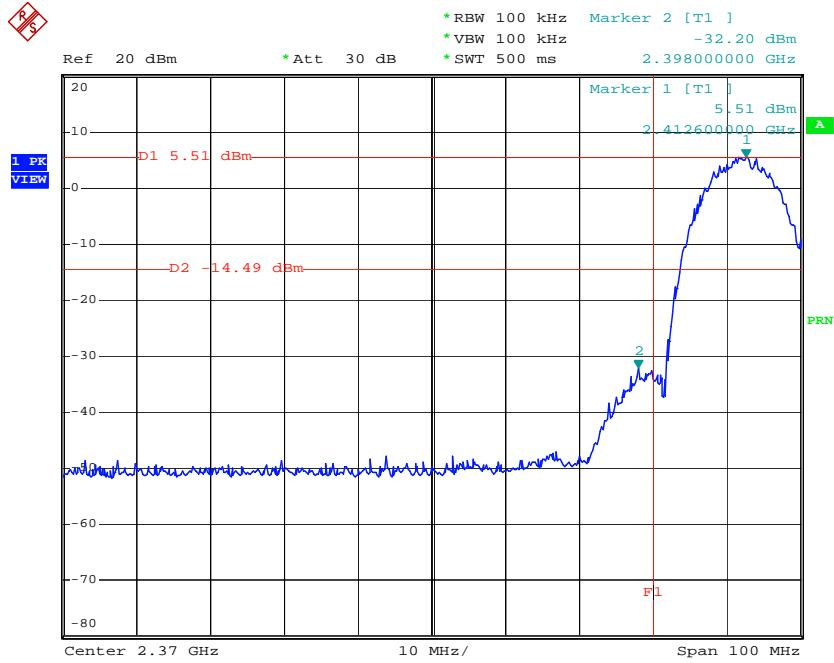

Date: 21.JUN.2005 11:53:21

Modulation Type: DSSS (Channel 11) :

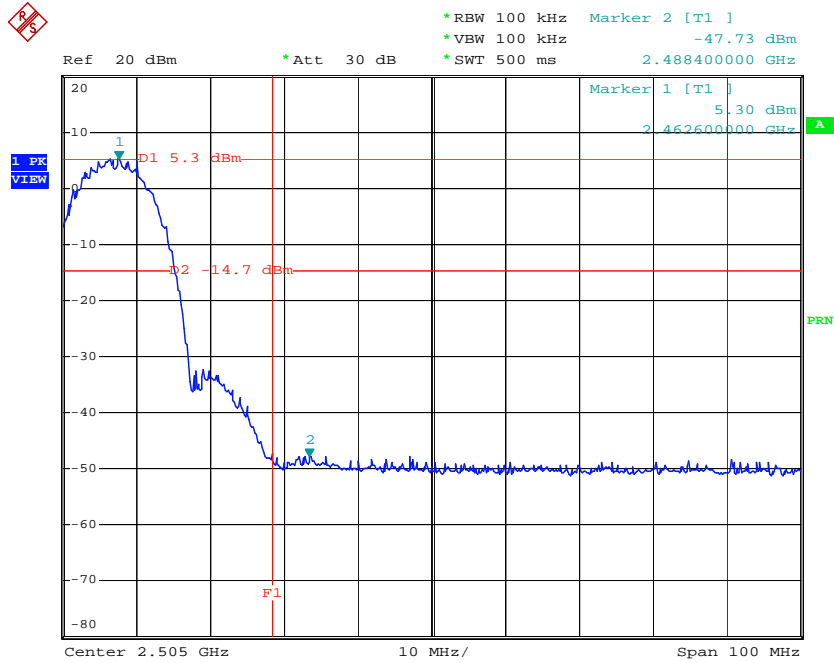

Date: 21.JUN.2005 11:51:52



Modulation Type: OFDM (Channel 01) :

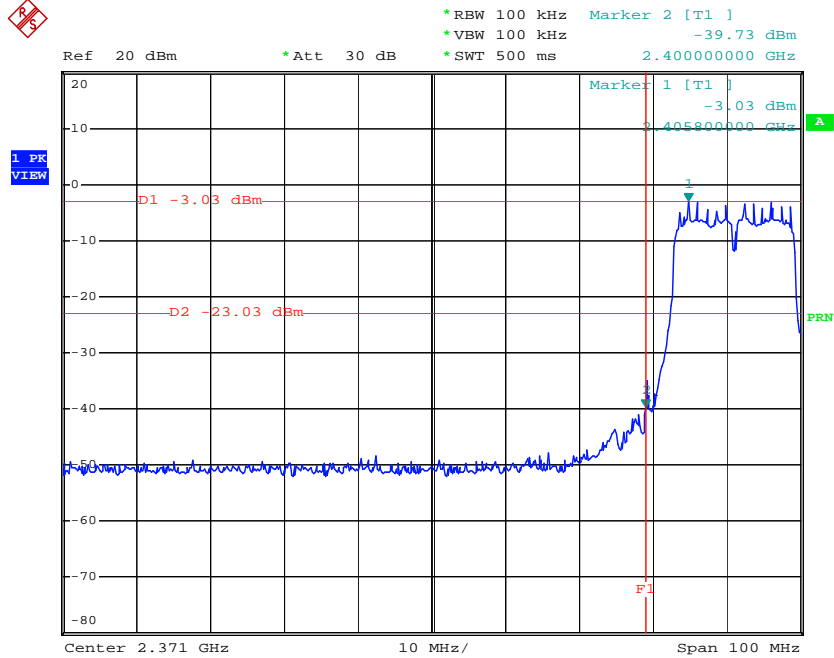

Date: 21.JUN.2005 12:10:14

Modulation Type: OFDM (Channel 11) :

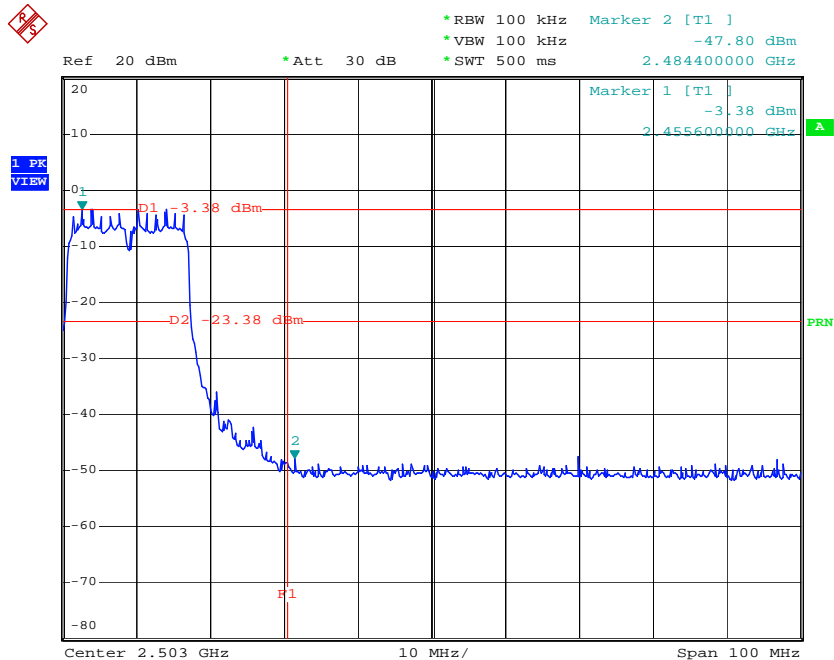

Date: 21.JUN.2005 12:18:54



## 5.5. Test of AC Power Line Conducted Emission

### 5.5.1. Applicable Standard

Section 15.207: For a Low-power Radio-frequency Device is designed to be connected to the AC power line, the radio frequency voltage that is conducted back onto the AC power line on any frequency or frequencies within the band 150 kHz to 30 MHz shall not exceed below limits table.

Frequency (MHz)	QP Limit (dBuV)	AV Limit (dBuV)
0.15~0.5	66~56	56~46
0.5~5	56	46
5~30	60	50

### 5.5.2. Measuring Instruments

Please reference item 1~5 in chapter 6 for the instruments used for testing.

### 5.5.3. Description of Major Test Instruments Setting

- Test Receiver : R&S ESCS 30
- Attenuation : 10 dB
- Start Frequency : 0.15 MHz
- Stop Frequency : 30 MHz
- IF Bandwidth : 9 KHz

### 5.5.4. Test Procedures

1. Configure the EUT according to ANSI C63.4.-2003
2. The EUT has to be placed 0.4 meter far from the conducting wall of the shielding room and at least 80 centimeters from any other grounded conducting surface.
3. Connect EUT to the power mains through a line impedance stabilization network (LISN)
4. All the support units are connected to the other LISNs. The LISN should provide 50uH/50ohms coupling impedance.
5. The frequency range from 150 KHz to 30 MHz was searched.
6. Set the test-receiver system to Peak Detect Function and Specified Bandwidth with Maximum Hold Mode.
7. The measurement has to be done between each power line and ground at the power terminal for each RF channel. Only one RF channel has to be investigated since this test is independent with the RF channel selection.

### 5.5.5. Test Setup Layout

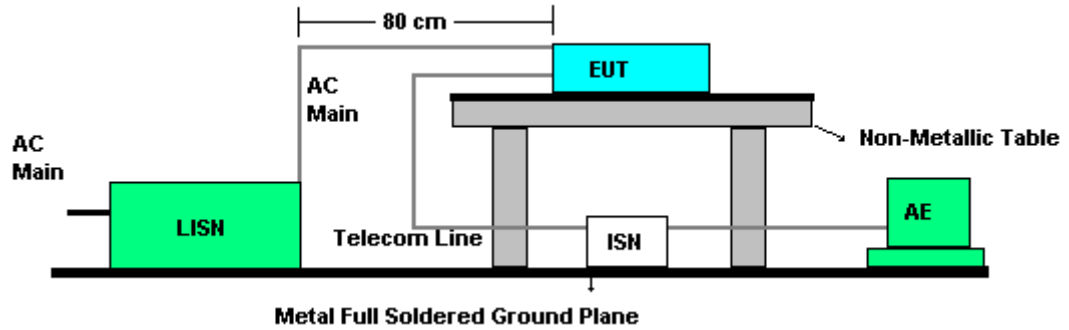

### 5.5.6. Test Criteria

All test results complied with the requirements of 15.207. Measurement Uncertainty is 2.54dB.





5.5.7. Test Result of Conducted Emission

- Test Mode: Normal Mode
- Temperature: 25°C
- Relative Humidity: 60%
- Test Engineer: Sky Wu

**Line to Ground**

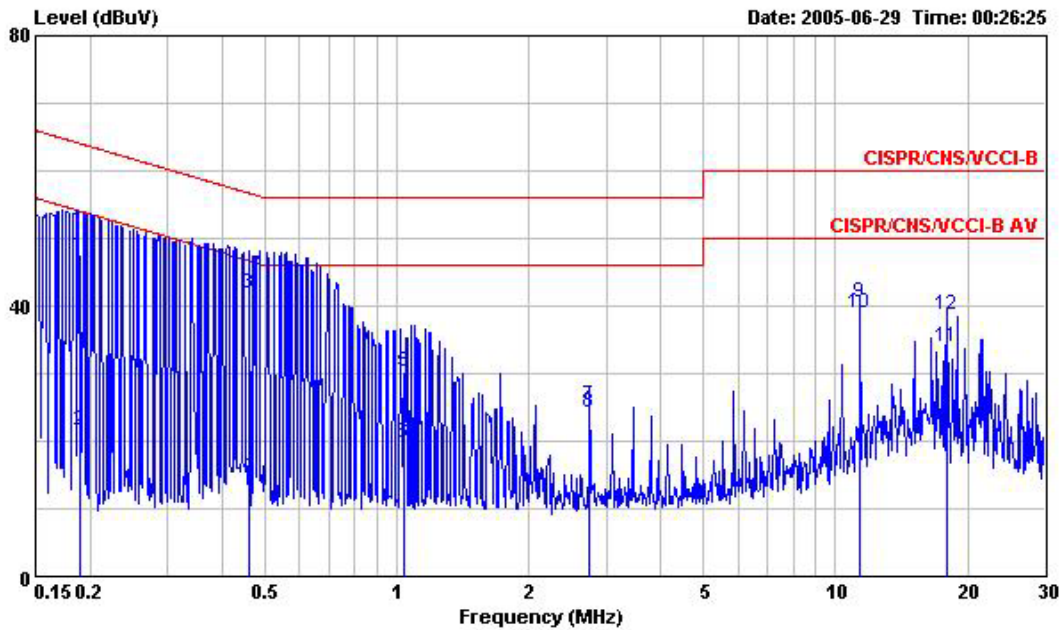

	Freq	Level	Over Limit	Limit Line	Read Level	LISN Factor	Cable Loss	Remark
	MHz	dBuV	dB	dBuV	dBuV	dB	dB	
1	0.1890990	47.59	-16.49	64.08	47.27	0.06	0.26	QP
2	0.1890990	21.58	-32.50	54.08	21.26	0.06	0.26	Average
3	0.4612220	41.83	-14.84	56.67	41.54	0.06	0.23	QP
4	0.4612220	14.69	-31.98	46.67	14.40	0.06	0.23	Average
5	1.034	30.35	-25.65	56.00	29.62	0.11	0.62	QP
6	1.034	19.62	-26.38	46.00	18.89	0.11	0.62	Average
7	2.751	25.29	-30.71	56.00	24.87	0.16	0.26	QP
8	2.751	24.18	-21.82	46.00	23.76	0.16	0.26	Average
9	11.353	40.63	-19.37	60.00	39.61	0.21	0.81	QP
10	11.353	38.94	-11.06	50.00	37.92	0.21	0.81	Average
11	17.888	33.97	-16.03	50.00	33.35	0.27	0.35	Average
12	17.888	38.80	-21.20	60.00	38.18	0.27	0.35	QP



**Neutral to Ground**

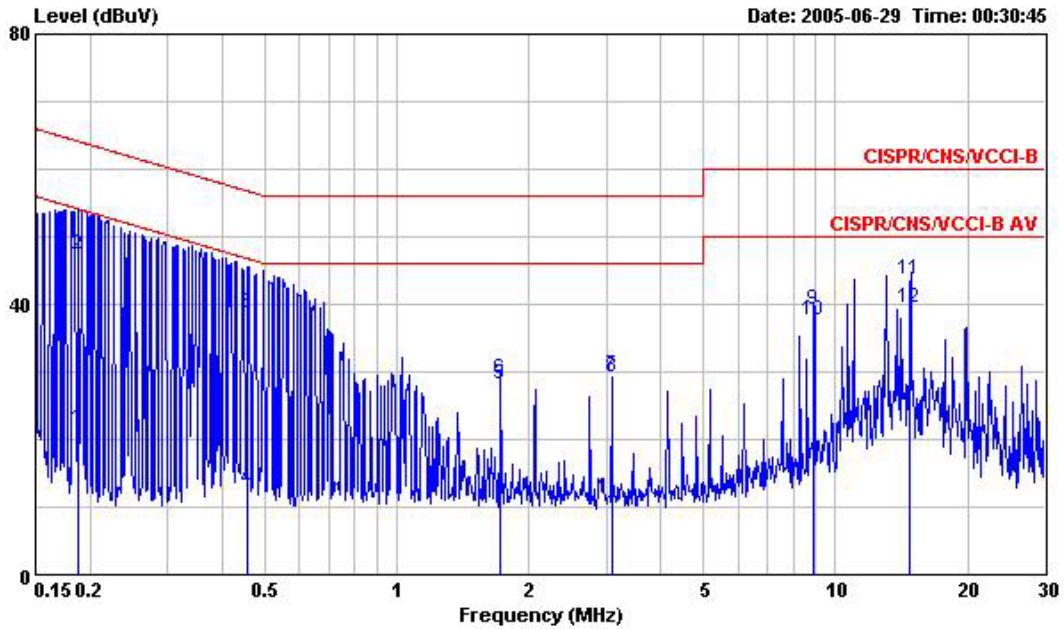

	Freq	Level	Over	Limit	Read	LISN	Cable	
	MHz	dBuV	Limit	Line	Level	Factor	Loss	Remark
			dB	dBuV	dBuV	dB	dB	
1	0.1883420	21.45	-32.66	54.11	21.07	0.11	0.27	Average
2	0.1883420	47.24	-16.87	64.11	46.86	0.11	0.27	QP
3	0.4563600	38.79	-17.97	56.76	38.45	0.11	0.23	QP
4	0.4563600	12.58	-34.18	46.76	12.24	0.11	0.23	Average
5	1.719	28.17	-17.83	46.00	27.63	0.23	0.31	Average
6	1.719	28.86	-27.14	56.00	28.32	0.23	0.31	QP
7	3.094	29.49	-26.51	56.00	28.99	0.23	0.27	QP
8	3.094	29.28	-16.72	46.00	28.78	0.23	0.27	Average
9	8.939	39.14	-20.86	60.00	38.42	0.32	0.40	QP
10	8.939	37.63	-12.37	50.00	36.91	0.32	0.40	Average
11	14.788	43.60	-16.40	60.00	42.30	0.33	0.97	QP
12	14.788	39.45	-10.55	50.00	38.15	0.33	0.97	Average

5.5.8. Photographs of Conducted Emission Test Configuration

FRONT VIEW



REAR VIEW





## 5.6. Test of Spurious Radiated Emission

### 5.6.1. Applicable Standard

Section 15.247(d): In any 100 kHz bandwidth outside the frequency band in which the spread spectrum or digitally modulated intentional radiator is operating, the radio frequency power that is produced by the intentional radiator shall be at least 20 dB below that in the 100 kHz bandwidth within the band that contains the highest level of the desired power, based on either an RF conducted or a radiated measurement. In addition, radiated emissions that fall in the restricted bands, as defined in Section 15.205, must also comply with the radiated emission limits specified in Section 15.209.

### 5.6.2. Measuring Instruments

Please reference item 6~20 in chapter 6 for the instruments used for testing.

### 5.6.3. Description of Major Test Instruments Setting

- Spectrum Analyzer : R&S FSP40
  - Attenuation : Auto
  - Start Frequency : 1000 MHz
  - Stop Frequency : 10th carrier harmonic
  - RB / VB : 1 MHz / 1MHz for Peak
  - RB / VB : 1 MHz / 10Hz for Average
  
- Test Receiver : R&S ESCS 30
  - Attenuation : Auto
  - Start Frequency : 9 kHz
  - Stop Frequency : 1000 MHz
  - RB : 120 KHz for QP or PK

### 5.6.4. Test Procedures

1. Configure the EUT according to ANSI C63.4.-2003
2. The EUT was placed on the top of the turntable 0.8 meter above ground.
3. The phase center of the receiving antenna mounted on the top of a height-variable antenna tower was placed 3 meters far away from the turntable.
4. Power on the EUT and all the supporting units.
5. The turntable was rotated by 360 degrees to determine the position of the highest radiation.
6. The height of the broadband receiving antenna was varied between one meter and four meters above ground to find the maximum emission field strength of both horizontal and vertical polarization.
7. For each suspected emission, the antenna tower was scan (from 1 M to 4 M) and then the turntable was rotated (from 0 degree to 360 degrees) to find the maximum reading.
8. Set the test-receiver system to Peak or CISPR quasi-peak Detect Function with specified bandwidth under Maximum Hold Mode.
9. For emission above 1GHz, use 1MHz VBW and RBW for peak reading. Then 1MHz RBW and 10Hz VBW

for average reading in spectrum analyzer.

10. If the emission level of the EUT in peak mode was 3 dB lower than the average limit specified, then testing will be stopped and peak values of EUT will be reported, otherwise, the emissions which do not have 3 dB margin will be repeated one by one using the quasi-peak method for below 1GHz and average method for above the 1GHz. the reported.
11. For testing above 1GHz, the emission level of the EUT in peak mode was 20dB higher than average limit (that means the emission level in peak mode also complies with the limit in average mode), then testing will be stopped and peak values of EUT will be reported, otherwise, the emissions will be measured in average mode again and reported.

#### 5.6.5. Test Setup Layout

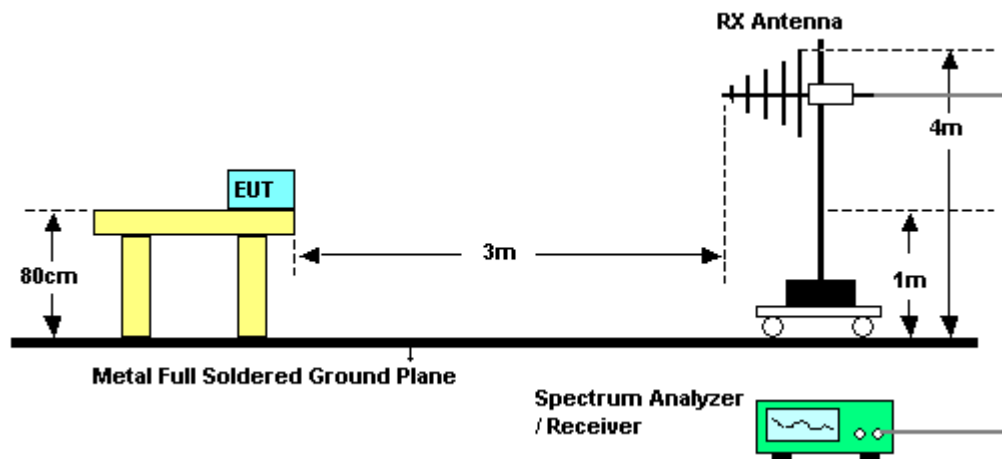

#### 5.6.6. Test Criteria

All test results complied with the requirements of 15.247(d). Measurement Uncertainty is 2.26dB.



5.6.7. Test Results for CH 06 / 2437 MHz (for emission below 1GHz)

- Modulation Type: OFDM
- Temperature: 25°C
- Relative Humidity: 60%
- Duty Cycle of the Equipment During the Test: 100.00%
- Test Engineer: Ted Chiu

**(A) Polarization: Horizontal**

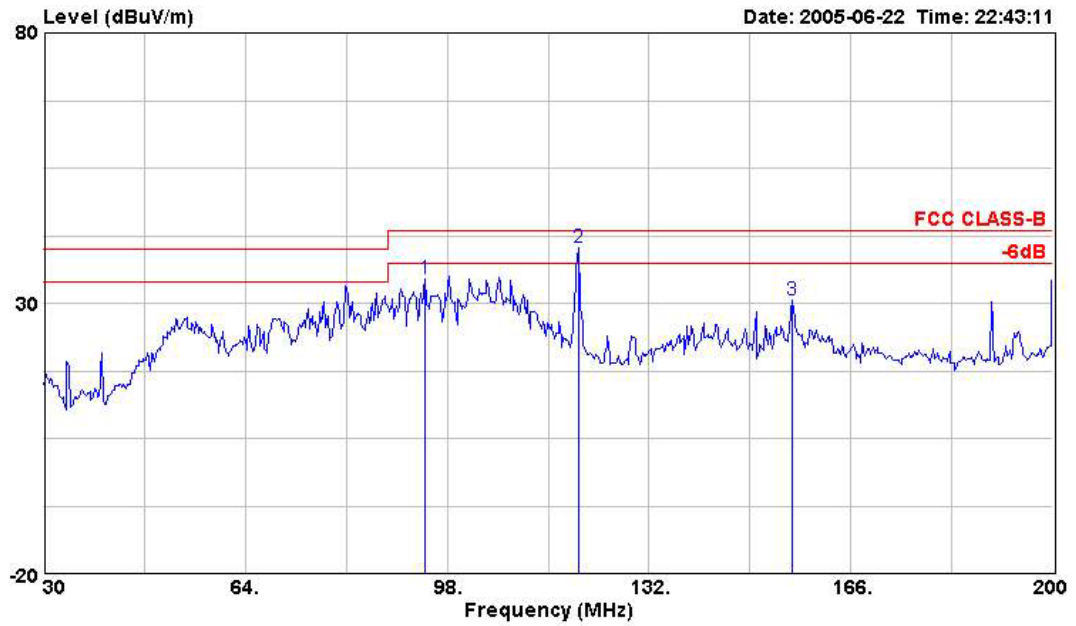

	Freq	Level	Over	Read	Limit	Line	Factor	Cable	Preamp	Remark	Ant	Table
	MHz	dBuV/m	dB	dBuV	dBuV/m	dB	dB	dB	dB		cm	deg
1	94.260	34.39	-9.11	54.37	43.50	-19.98	0.93	29.63	Peak	---	---	
2	120.100	40.40	-3.10	57.73	43.50	-17.33	1.09	30.32	Peak	---	---	
3	156.140	30.50	-13.00	47.38	43.50	-16.88	1.25	30.46	Peak	---	---	

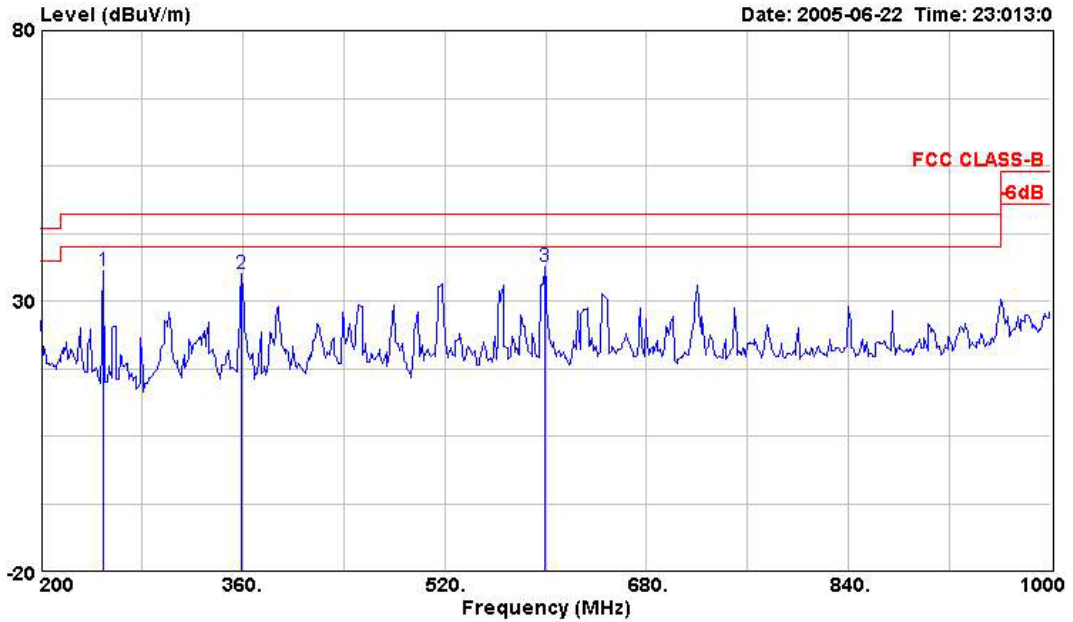

	Freq	Level	Over	Read	Limit	Cable	Preamp		Ant	Table
	MHz	dBUV/m	Limit	Level	Line	Loss	Factor	Remark	Pos	Pos
			dB	dBuV	dBUV/m	dB	dB		cm	deg
1	249.600	35.56	-10.44	52.22	46.00	-16.66	1.53	30.49 Peak	---	---
2	359.200	35.11	-10.89	48.41	46.00	-13.30	1.81	30.70 Peak	---	---
3	599.200	36.23	-9.77	44.56	46.00	-8.33	2.40	31.09 Peak	---	---



**(B) Polarization: Vertical**

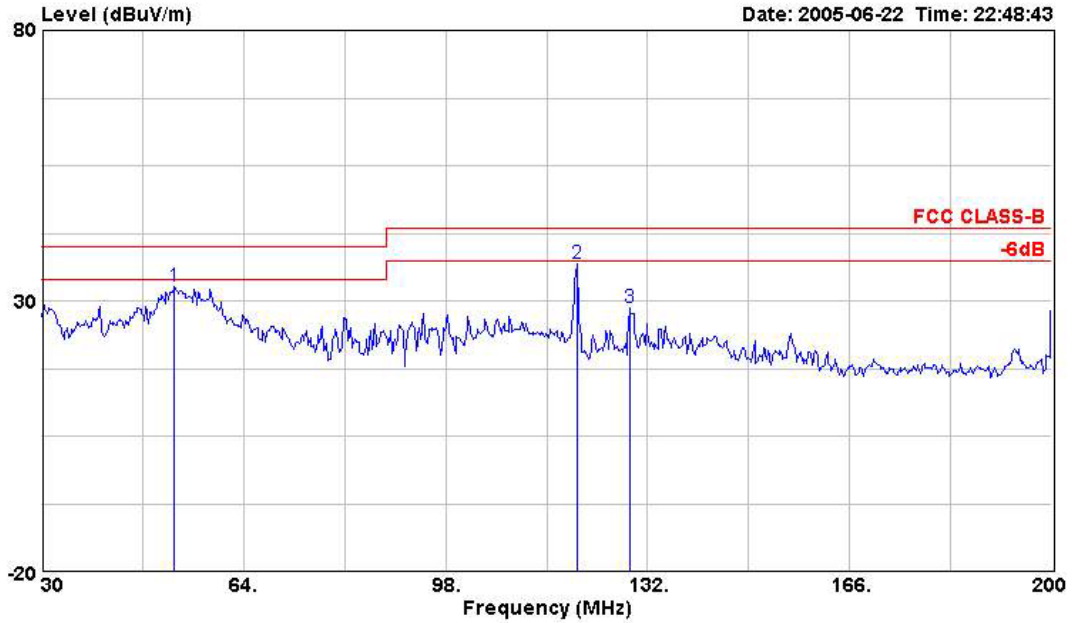

	Freq	Level	Over	Read	Limit	Cable	Preamp		Ant	Table
	MHz	dBuV/m	Limit	Level	Line	Loss	Factor	Remark	Pos	Pos
			dB	dBuV	dBuV/m	dB	dB		cm	deg
1	52.270	32.60	-7.40	50.82	40.00	-18.22	0.70	30.12 Peak	---	---
2	120.100	36.76	-6.74	54.09	43.50	-17.33	1.09	30.32 Peak	---	---
3	128.940	28.65	-14.85	45.87	43.50	-17.22	1.13	30.65 Peak	---	---



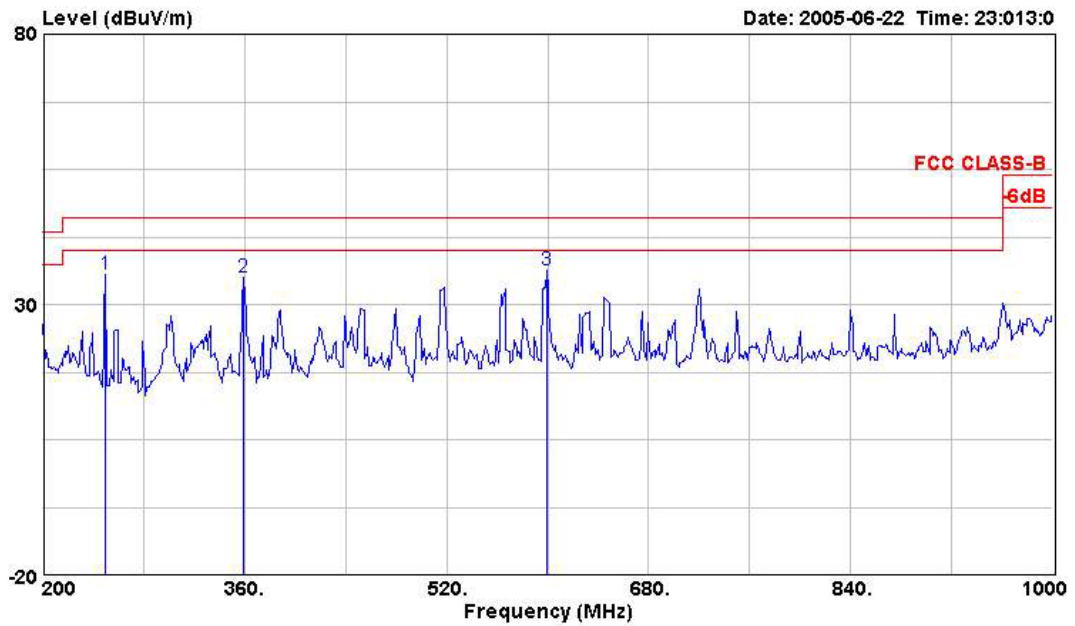

	Freq	Level	Over	Read	Limit		Cable	Preamp		Ant	Table
	MHz	dBuV/m	Limit	Level	Line	Factor	Loss	Factor	Remark	Pos	Pos
			dB	dBuV	dBuV/m	dB	dB	dB		cm	deg
1	249.600	35.56	-10.44	52.22	46.00	-16.66	1.53	30.49	Peak	---	---
2	359.200	35.11	-10.89	48.41	46.00	-13.30	1.81	30.70	Peak	---	---
3	599.200	36.23	-9.77	44.56	46.00	-8.33	2.40	31.09	Peak	---	---

Note:

Emission level (dBuV/m) = 20 log Emission level (uV/m)

Corrected Reading: Probe Factor + Cable Loss + Read Level - Preamp Factor = Level

Results for the radiated measurement below 30MHz, no emissions found and caused by the EUT.

The amplitude of spurious emissions which are attenuated more than 20 dB below the permissible value need not be reported.



5.6.8. Test Results for CH 01 / 2412 MHz (for emission above 1GHz)

- Modulation Type: DSSS
- Temperature: 25°C
- Relative Humidity: 60%
- Duty Cycle of the Equipment During the Test: 100.00%
- Test Engineer: Ted Chiu

(A) Polarization: Horizontal

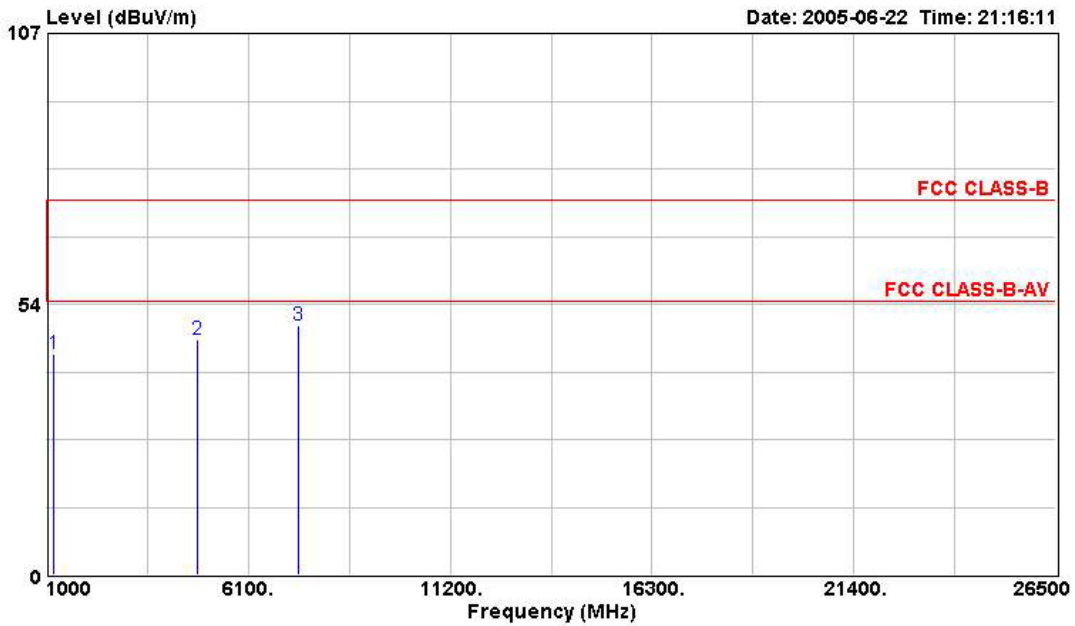

	Freq	Level	Over	Read	Limit	Cable Preamp		Remark	Ant	Table
	MHz	dBuV/m	Limit	Level	Line	Factor	Loss	Factor	Pos	Pos
			dB	dBuV	dBuV/m	dB	dB	dB	cm	deg
1	1196.000	43.77	-30.23	51.43	74.00	-7.66	1.32	33.69	Peak	---
2	4824.000	46.49	-27.51	43.07	74.00	3.42	2.84	32.54	PEAK	---
3	7368.000	49.30	-24.70	42.04	74.00	7.26	3.66	32.71	PEAK	---



**(B) Polarization: Vertical**

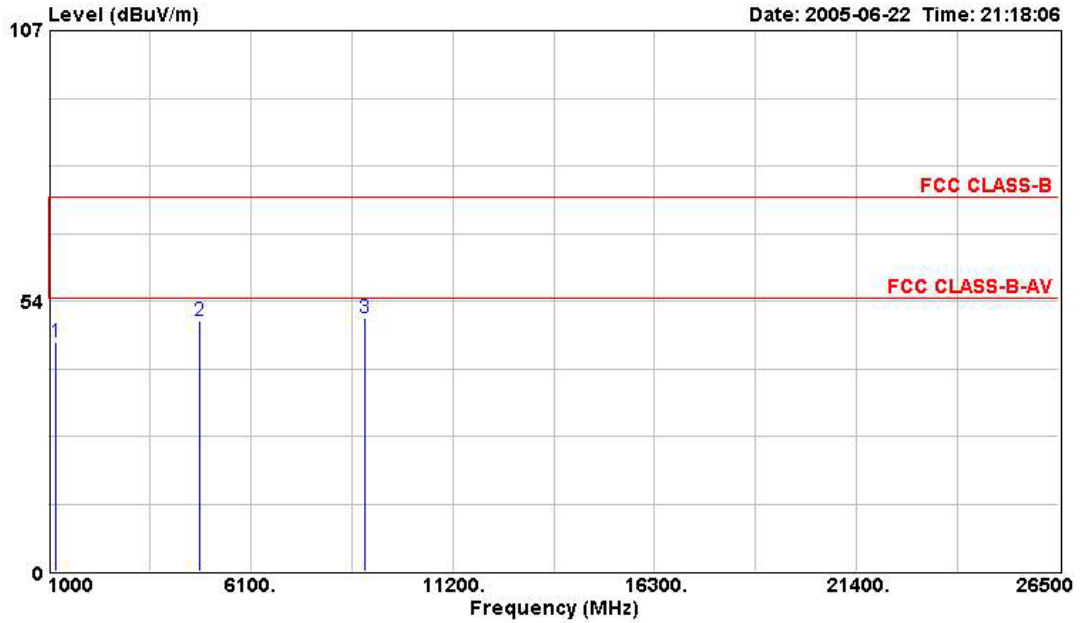

	Freq	Level	Over Limit	Read Level	Limit Line	Cable Loss	Preamp Factor	Remark	Ant Pos	Table Pos
	MHz	dBUV/m	dB	dBuV	dBUV/m	dB	dB		cm	deg
1	1196.000	45.34	-28.66	53.00	74.00	-7.66	1.32	33.69 Peak	---	---
2	4824.000	49.57	-24.43	46.15	74.00	3.42	2.84	32.54 PEAK	---	---
3	8988.000	50.10	-23.90	41.44	74.00	8.66	4.06	33.30 PEAK	---	---

Note:

Emission level (dBUV/m) = 20 log Emission level (uV/m)

Corrected Reading: Probe Factor + Cable Loss + Read Level - Preamp Factor = Level



- Modulation Type: OFDM
- Temperature: 25°C
- Relative Humidity: 60%
- Duty Cycle of the Equipment During the Test: 100.00%
- Test Engineer: Ted Chiu

**(A) Polarization: Horizontal**

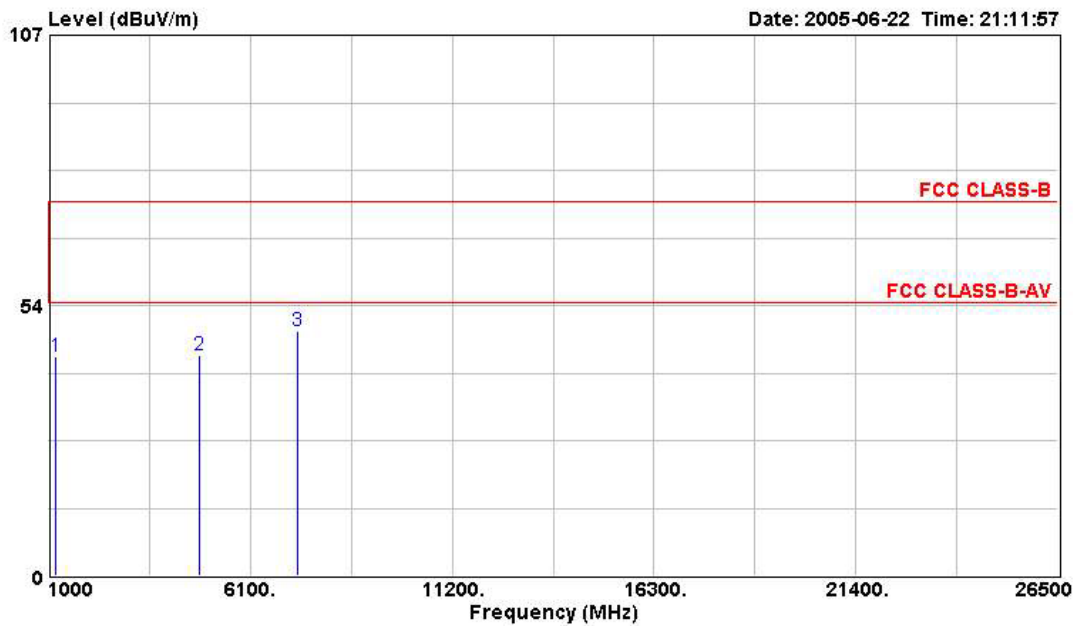

	Freq	Level	Over Limit	Read Level	Limit Line	Factor	Cable Loss	Preamp Factor	Remark	Ant Pos	Table Pos
	MHz	dBuV/m	dB	dBuV	dBuV/m	dB	dB	dB		cm	deg
1	1190.000	43.37	-30.63	51.12	74.00	-7.75	1.32	33.74	Peak	---	---
2	4824.000	43.78	-30.22	40.36	74.00	3.42	2.84	32.54	PEAK	---	---
3	7296.000	48.36	-25.64	41.16	74.00	7.19	3.65	32.56	PEAK	---	---



**(B) Polarization: Vertical**

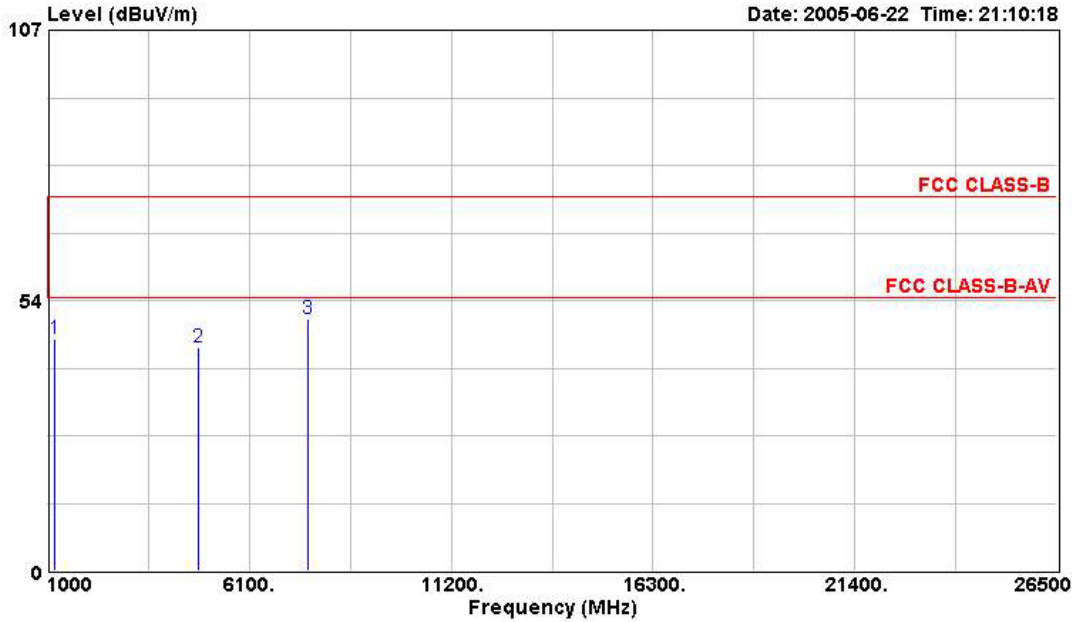

	Freq	Level	Over	Read	Limit	Cable	Preamp	Remark	Ant	Table
	MHz	dBuV/m	Limit	Level	Line	Loss	Factor		Pos	Pos
			dB	dBuV	dBuV/m	dB	dB		cm	deg
1	1196.000	45.82	-28.18	53.48	74.00	-7.66	1.32	33.69 Peak	---	---
2	4824.000	44.15	-29.85	40.73	74.00	3.42	2.84	32.54 PEAK	---	---
3	7584.000	49.73	-24.27	42.27	74.00	7.45	3.74	32.97 PEAK	---	---

Note:

Emission level (dBuV/m) = 20 log Emission level (uV/m)

Corrected Reading: Probe Factor + Cable Loss + Read Level - Preamp Factor = Level



5.6.9. Test Results for CH 06 / 2437 MHz (for emission above 1GHz)

- Modulation Type: DSSS
- Temperature: 25°C
- Relative Humidity: 60%
- Duty Cycle of the Equipment During the Test: 100.00%
- Test Engineer: Ted Chiu

**(A) Polarization: Horizontal**

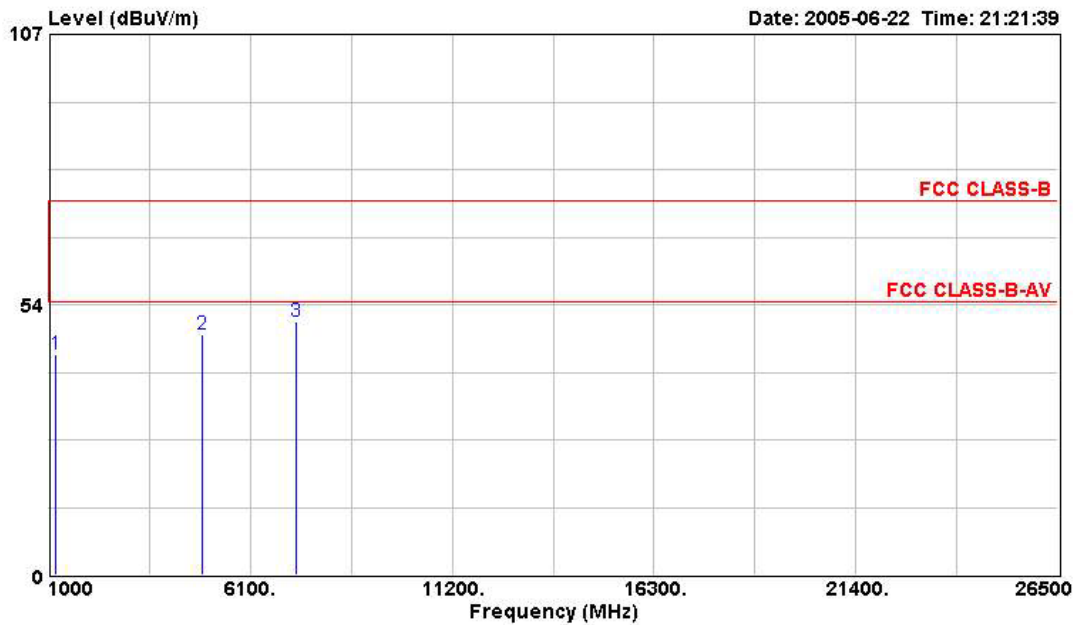

	Freq	Level	Over	Read	Limit	Cable	Preamp	Remark	Ant	Table
	MHz	dBuV/m	Limit	Level	Line	Loss	Factor		Pos	Pos
			dB	dBuV	dBuV/m	dB	dB		cm	deg
1	1196.000	43.57	-30.43	51.23	74.00	-7.66	1.32	33.69 Peak	---	---
2	4876.000	47.53	-26.47	43.99	74.00	3.53	2.87	32.55 PEAK	---	---
3	7260.000	50.15	-23.85	42.95	74.00	7.20	3.64	32.46 PEAK	---	---



**(B) Polarization: Vertical**

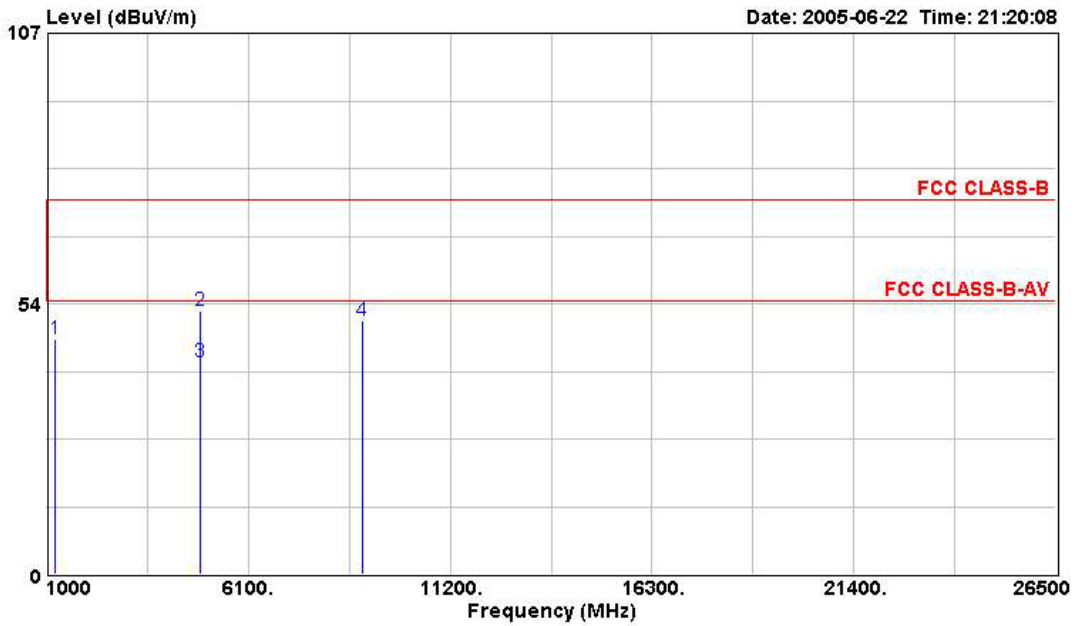

	Freq	Level	Over	Read	Limit		Cable	Preamp		Ant	Table
	MHz	dBuV/m	Limit	Level	Line	Factor	Loss	Factor	Remark	Pos	Pos
			dB	dBuV	dBuV/m	dB	dB	dB		cm	deg
1	1198.000	46.44	-27.56	54.10	74.00	-7.66	1.32	33.69	Peak	---	---
2	4876.000	51.98	-22.02	48.45	74.00	3.53	2.87	32.55	PEAK	---	---
3	4876.000	41.94	-12.06	38.41	54.00	3.53	2.87	32.55	Average	---	---
4	8988.000	50.10	-23.90	41.44	74.00	8.66	4.06	33.30	PEAK	---	---

Note:

Emission level (dBuV/m) = 20 log Emission level (uV/m)

Corrected Reading: Probe Factor + Cable Loss + Read Level - Preamp Factor = Level



- Modulation Type: OFDM
- Temperature: 25°C
- Relative Humidity: 60%
- Duty Cycle of the Equipment During the Test: 100.00%
- Test Engineer: Ted Chiu

**(A) Polarization: Horizontal**

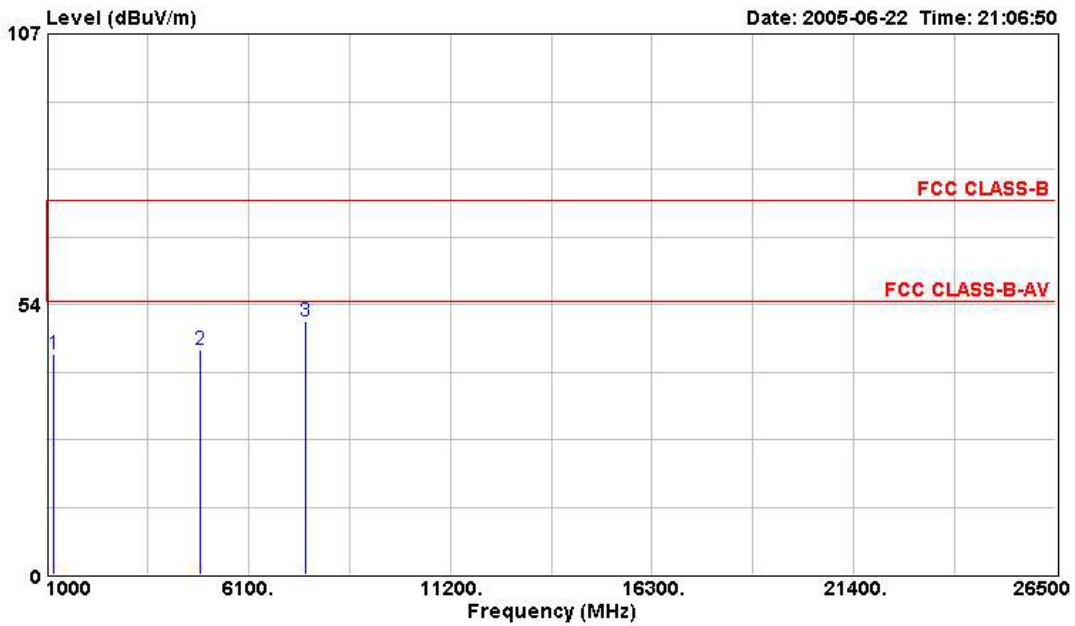

	Freq	Level	Over	Read	Limit		Cable	Preamp		Ant	Table
	MHz	dBuV/m	dB	Level	Line	Factor	Loss	Factor	Remark	Pos	Pos
				dBuV	dBuV/m	dB	dB	dB		cm	deg
1	1196.000	43.64	-30.36	51.30	74.00	-7.66	1.32	33.69	Peak	---	---
2	4876.000	44.49	-29.51	40.96	74.00	3.53	2.87	32.55	PEAK	---	---
3	7528.000	50.06	-23.94	42.66	74.00	7.39	3.73	32.97	PEAK	---	---





**(B) Polarization: Vertical**

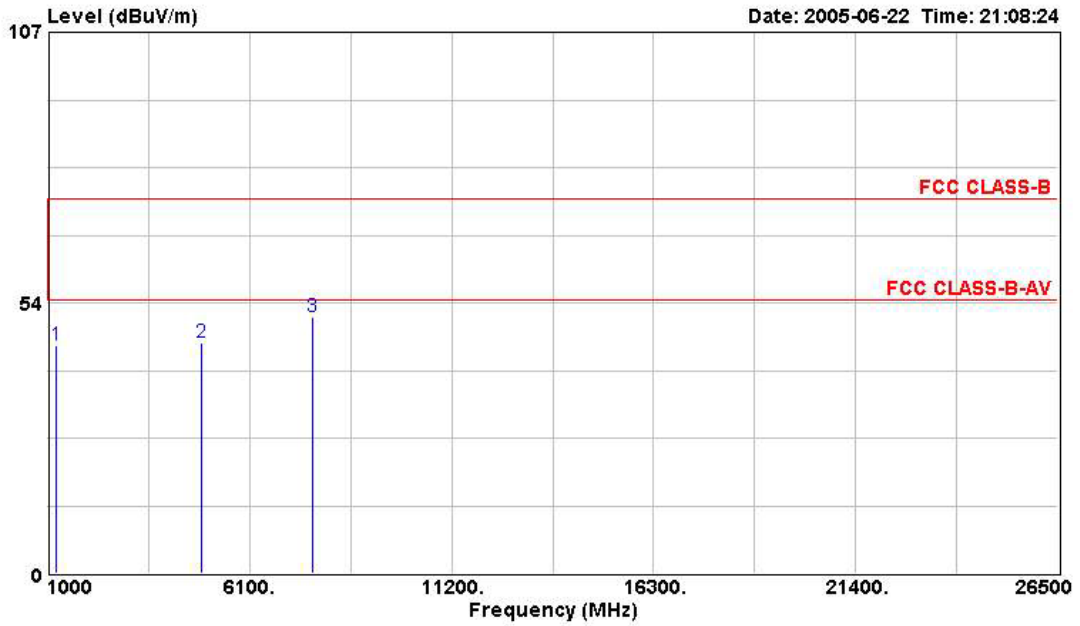

	Freq	Level	Over	Read	Limit		Cable	Preamp		Ant	Table
	MHz	dBUV/m	Limit	Level	Line	Factor	Loss	Factor	Remark	Pos	Pos
			dB	dBuV	dBUV/m	dB	dB	dB		cm	deg
1	1198.000	45.19	-28.81	52.85	74.00	-7.66	1.32	33.69	Peak	---	---
2	4872.000	45.77	-28.23	42.23	74.00	3.53	2.87	32.55	PEAK	---	---
3	7696.000	50.72	-23.28	43.11	74.00	7.61	3.78	32.97	PEAK	---	---

Note:

Emission level (dBUV/m) = 20 log Emission level (uV/m)

Corrected Reading: Probe Factor + Cable Loss + Read Level - Preamp Factor = Level



5.6.10. Test Results for CH 11 / 2462 MHz (for emission above 1GHz)

- Modulation Type: DSSS
- Temperature: 25°C
- Relative Humidity: 60%
- Duty Cycle of the Equipment During the Test: 100.00%
- Test Engineer: Ted Chiu

**(A) Polarization: Horizontal**

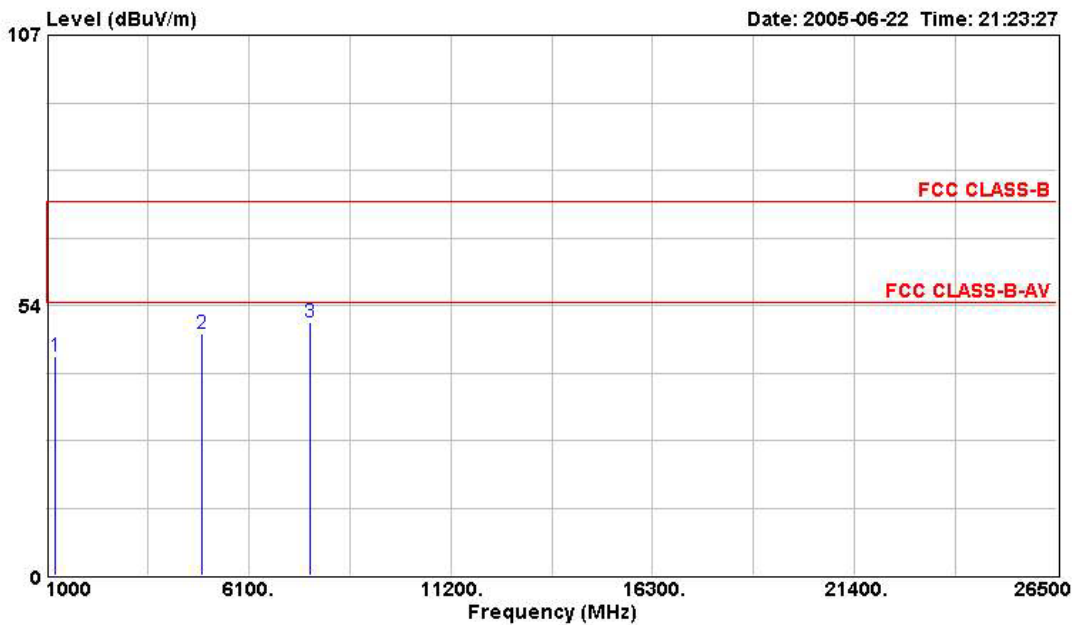

	Freq	Level	Over	Read	Limit	Cable	Preamp	Remark	Ant	Table
	MHz	dBuV/m	Limit	Level	Line	Loss	Factor		Pos	Pos
			dB	dBuV	dBuV/m	dB	dB		cm	deg
1	1198.000	43.34	-30.66	51.00	74.00	-7.66	1.32	33.69	Peak	---
2	4924.000	47.98	-26.02	44.35	74.00	3.63	2.89	32.55	PEAK	---
3	7664.000	50.01	-23.99	42.45	74.00	7.56	3.77	32.97	PEAK	---



**(B) Polarization: Vertical**

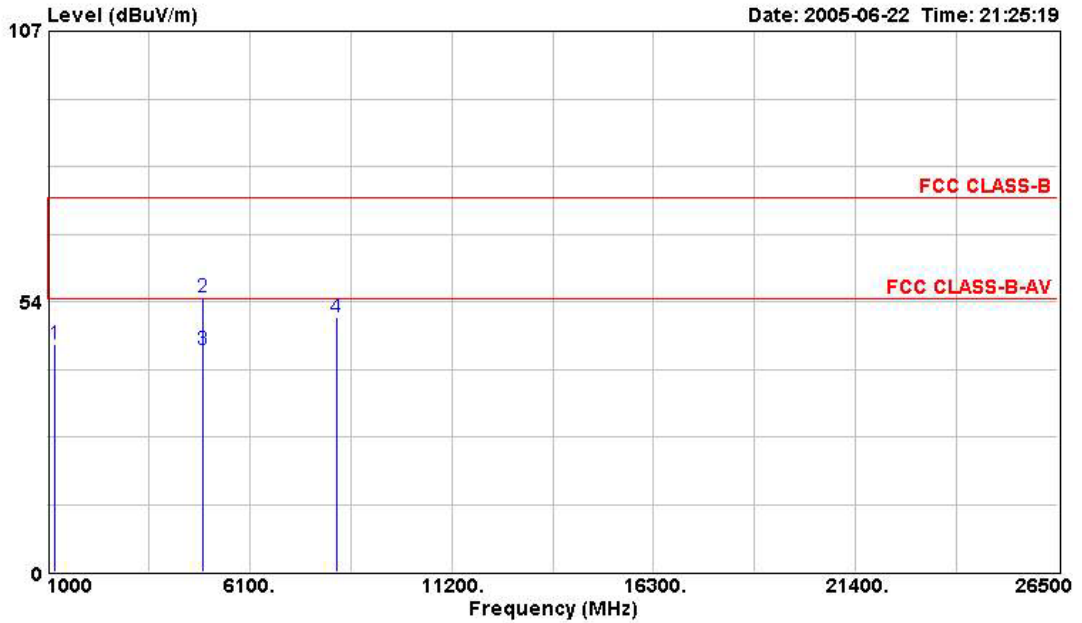

	Freq	Level	Over	Read	Limit	Cable	Preamp		Ant	Table
	MHz	dBuV/m	Limit	Level	Line	Loss	Factor	Remark	Pos	Pos
			dB	dBuV	dBuV/m	dB	dB		cm	deg
1	1196.000	45.02	-28.98	52.68	74.00	-7.66	1.32	33.69 Peak	---	---
2	4924.000	54.47	-19.53	50.85	74.00	3.63	2.89	32.55 Peak	---	---
3	4924.000	43.95	-10.05	40.32	54.00	3.63	2.89	32.55 Average	---	---
4	8296.000	50.30	-23.70	41.78	74.00	8.52	3.94	32.99 Peak	---	---

Note:

Emission level (dBUV/m) = 20 log Emission level (uV/m)

Corrected Reading: Probe Factor + Cable Loss + Read Level - Preamp Factor = Level



- Modulation Type: OFDM
- Temperature: 25°C
- Relative Humidity: 60%
- Duty Cycle of the Equipment During the Test: 100.00%
- Test Engineer: Ted Chiu

**(A) Polarization: Horizontal**

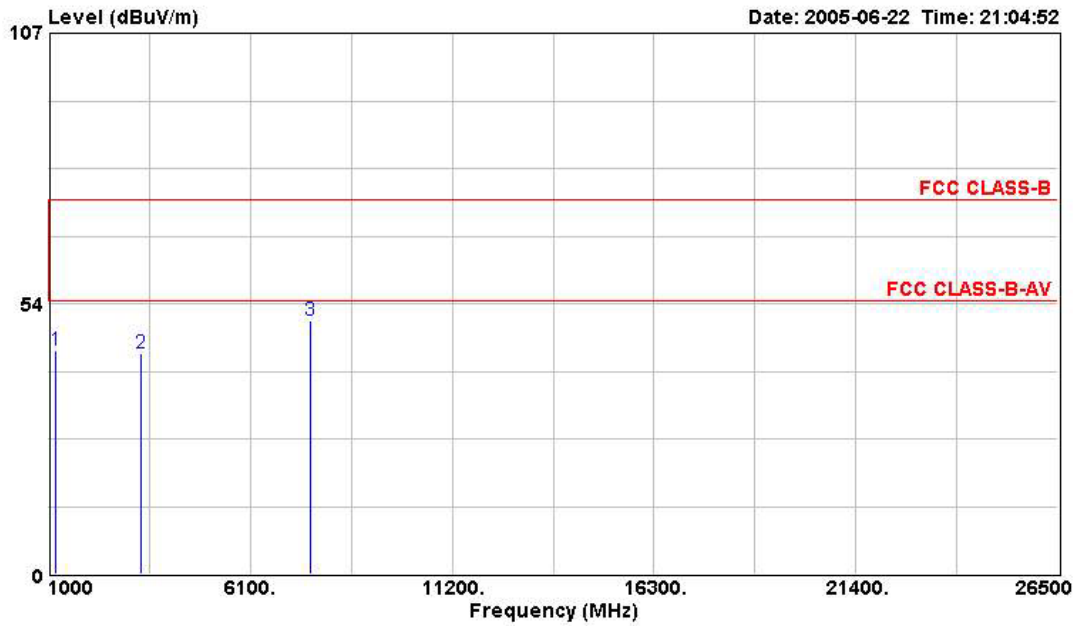

	Freq	Level	Over	Read	Limit	Cable	Preamp		Ant	Table
	MHz	dBuV/m	Limit	Level	Line	Loss	Factor	Remark	Pos	Pos
			dB	dBuV	dBuV/m	dB	dB		cm	deg
1	1196.000	44.09	-29.91	51.75	74.00	-7.66	1.32	33.69 Peak	---	---
2	3324.000	43.80	-30.20	43.38	74.00	0.42	2.29	32.69 PEAK	---	---
3	7608.000	50.10	-23.90	42.60	74.00	7.50	3.76	32.97 PEAK	---	---



**(B) Polarization: Vertical**

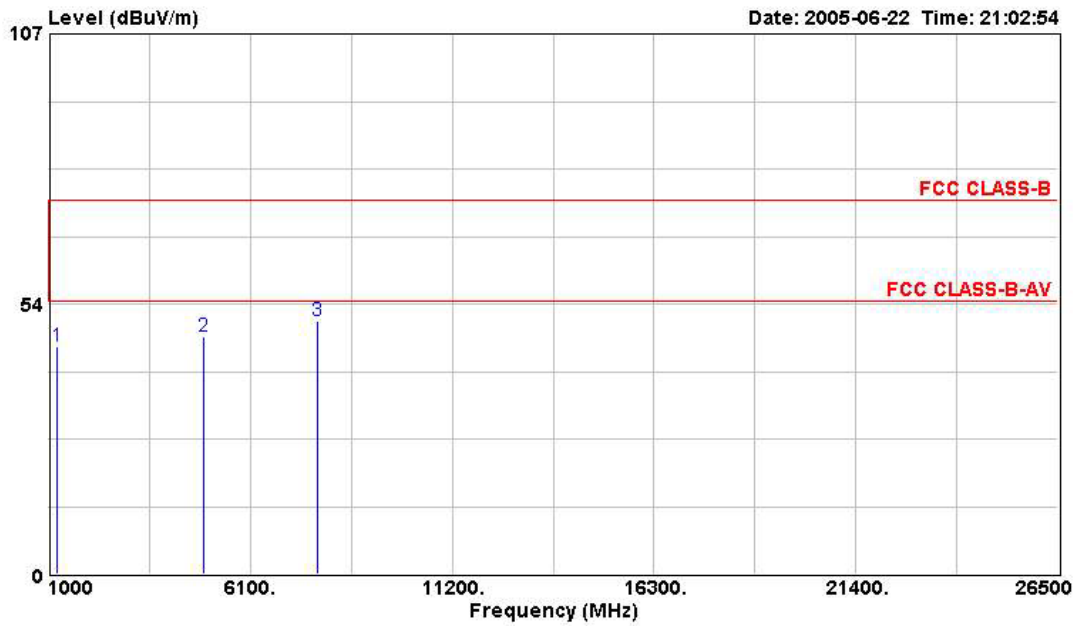

	Freq	Level	Over	Read	Limit	Cable Preamp		Remark	Ant	Table
	MHz	dBuV/m	Limit	Level	Line	Loss	Factor		Pos	Pos
			dB	dBuV	dBuV/m	dB	dB		cm	deg
1	1198.000	44.93	-29.07	52.59	74.00	-7.66	1.32	33.69	Peak	---
2	4924.000	47.15	-26.85	43.52	74.00	3.63	2.89	32.55	PEAK	---
3	7800.000	50.18	-23.82	42.43	74.00	7.75	3.82	32.98	PEAK	---

Note:

Emission level (dBuV/m) = 20 log Emission level (uV/m)

Corrected Reading: Probe Factor + Cable Loss + Read Level - Preamp Factor = Level

5.6.11. Photographs of Radiated Emission Test Configuration

FRONT VIEW

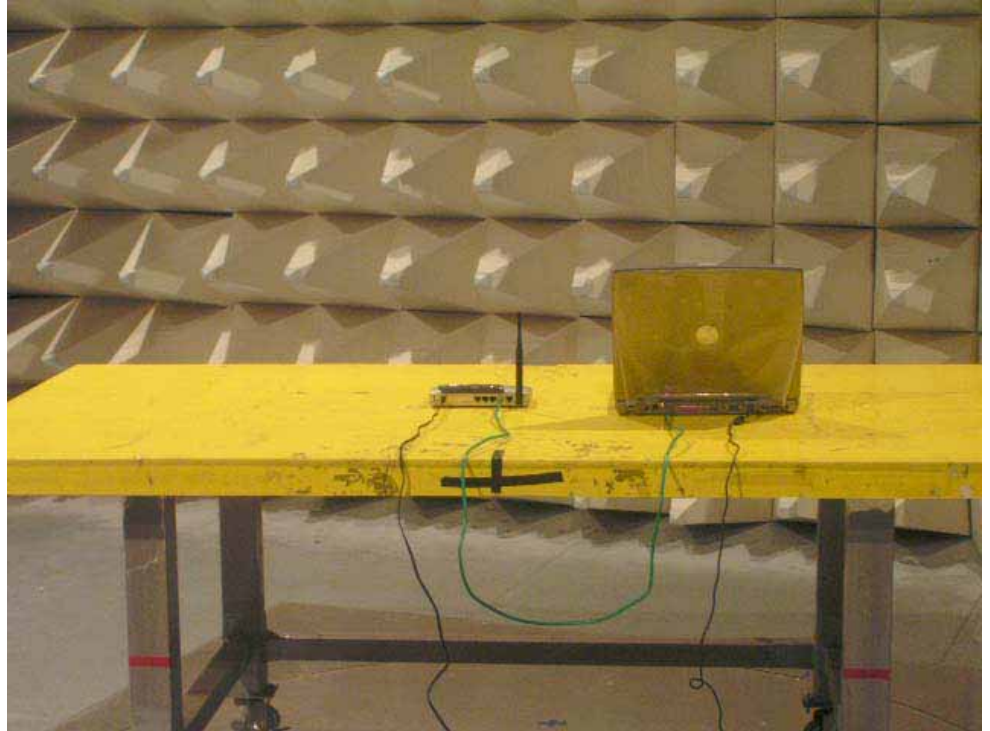

REAR VIEW

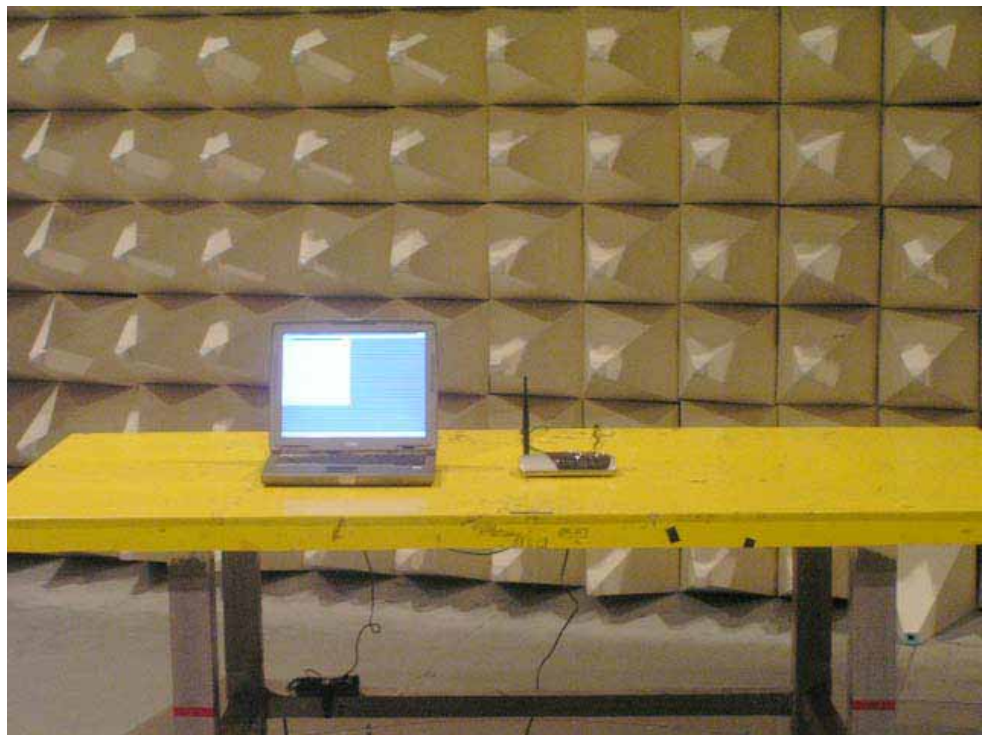



## 5.7. Antenna Requirements

### 5.7.1. Standard Applicable

Section 15.203:

An intentional radiator shall be designed to ensure that no antenna other than that furnished by the responsible party shall be used with the device. The use of a permanently attached antenna or of an antenna that uses a unique coupling to the intentional radiator shall be considered sufficient to comply with the provisions of this Section. The manufacturer may design the unit so that a broken antenna can be replaced by the user, but the use of a standard antenna jack or electrical connector is prohibited.

Section 15.247(b)/(c):

If transmitting antennas of directional gain greater than 6 dBi are used, the peak output power from the intentional radiator shall be reduced by the amount in dB that the directional gain of the antenna exceeds 6 dBi.

If the intentional radiator is used exclusively for fixed, point-to-point operations may employ transmitting antennas with directional gain greater than 6 dBi provided the maximum peak output power of the intentional radiator is reduced by 1 dB for every 3 dB that the directional gain of the antenna exceeds 6 dBi.

### 5.7.2. Antenna Connected Construction

External antenna uses Reverse- SMA connector.

### 5.7.3. Antenna Gain

Antenna gain of EUT is less than 6dBi. Therefore peak conducted power limit shall not be degraded any more. Antenna report of manufacturer will have more detail antenna gain or antenna pattern.

### 5.7.4. Test Criteria

All test results complied with the requirements of 15.203/15.247(b)/(c).

## 5.8. RF Exposure

### 5.8.1. Limit For Maximum Permissible Exposure (MPE)

This product can be classified as mobile device, so the 20cm separation distance warning is required. In this section, the power density at 20cm location is calculated to examine if it is lower than the limit.

#### (A) Limits for Occupational / Controlled Exposure

Frequency Range (MHz)	Electric Field Strength (E) (V/m)	Magnetic Field Strength (H) (A/m)	Power Density (S) (mW/ cm <sup>2</sup> )	Averaging Time  E  <sup>2</sup> , H  <sup>2</sup> or S (minutes)
0.3-3.0	614	1.63	(100)*	6
3.0-30	1842 / f	4.89 / f	(900 / f)*	6
30-300	61.4	0.163	1.0	6
300-1500			F/300	6
1500-100,000			5	6

#### (B) Limits for General Population / Uncontrolled Exposure

Frequency Range (MHz)	Electric Field Strength (E) (V/m)	Magnetic Field Strength (H) (A/m)	Power Density (S) (mW/cm <sup>2</sup> )	Averaging Time  E  <sup>2</sup> , H  <sup>2</sup> or S ( minutes )
0.3-1.34	614	1.63	(100)*	30
1.34-30	824/f	2.19/f	(180/f)*	30
30-300	27.5	0.073	0.2	30
300-1500			F/1500	30
1500-100,000			1.0	30

F = frequency in MHz

\*Plane-wave equivalent power density

### 5.8.2. MPE Calculation Method

$$E \text{ (V/m)} = \frac{\sqrt{30 \times P \times G}}{d} \quad \text{Power Density: } Pd \text{ (mW/cm}^2\text{)} = \frac{E^2}{377}$$

**E** = Electric field (V/m)

**P** = Peak RF output power (mW)

**G** = EUT Antenna numeric gain (numeric)

**d** = Separation distance between radiator and human body (m)

The formula can be changed to

$$Pd = \frac{30 \times P \times G}{377 \times d^2}$$

From the peak EUT RF output power, the minimum mobile separation distance, d=20cm, as well as the gain of the used antenna, the RF power density can be obtained.





5.8.3. Calculated Result and Limit

- Modulation Type: DSSS
- Temperature: 25°C
- Relative Humidity: 60%
- Duty Cycle of the Equipment During the Test: 100.00%
- Test Engineer: Eason Lu

Channel No.	Antenna Gain (dBi)	Antenna Gain (numeric)	Peak Output Power (dBm)	Peak Output Power ( mW )	Power Density (S) (mW/cm <sup>2</sup> )	Limit of Power Density (S) (mW/cm <sup>2</sup> )
01	5.00	3.16	18.18	65.77	0.0414	1
06	5.00	3.16	18.34	68.23	0.0429	1
11	5.00	3.16	18.26	66.99	0.0421	1

- Modulation Type: OFDM
- Temperature: 25°C
- Relative Humidity: 60%
- Duty Cycle of the Equipment During the Test: 100.00%
- Test Engineer: Eason Lu

Channel No.	Antenna Gain (dBi)	Antenna Gain (numeric)	Peak Output Power (dBm)	Peak Output Power ( mW )	Power Density (S) (mW/cm <sup>2</sup> )	Limit of Power Density (S) (mW/cm <sup>2</sup> )
01	5.00	3.16	15.27	33.65	0.0212	1
06	5.00	3.16	15.54	35.81	0.0225	1
11	5.00	3.16	15.46	35.16	0.0221	1



## 6. List of Measuring Equipments Used

Items	Instrument	Manufacturer	Model No.	Serial No.	Characteristics	Calibration Date	Remark
1	EMC Receiver	R&S	ESCS 30	100174	9kHz – 2.75GHz	Feb. 16, 2005	Conduction (CO04-HY)
2	LISN	MessTec	NNB-2/16Z	2001/004	9kHz – 30MHz	Apr. 20, 2005	Conduction (CO04-HY)
3	LISN (Support Unit)	MessTec	NNB-2/16Z	99041	9kHz – 30MHz	May. 05, 2005	Conduction (CO04-HY)
4	RF Cable-CON	UTIFLEX	3102-26886-4	CB049	9kHz – 30MHz	Apr. 20, 2005	Conduction (CO04-HY)
5	EMI Filter	LINDGREN	LRE-2030	2651	< 450 Hz	N/A	Conduction (CO04-HY)
6	3m Semi Anechoic Chamber	SIDT FRANKONIA	SAC-3M	03CH03-HY	30MHz ~ 1GHz 3m	Jun. 16, 2005	Radiation (03CH03-HY)
7	Spectrum analyzer	R&S	FSP40	100004	9KHZ ~ 40GHz	Aug. 31, 2004	Radiation (03CH03-HY)
9	Amplifier	SCHAFFNER	CPA9231A	18667	9KHz ~ 2GHz	Jan. 10, 2005	Radiation (03CH03-HY)
10	Amplifier	Agilent	8449B	3008A02120	1GHz ~ 26.5GHz	May 31, 2005	Radiation (03CH03-HY)
11	Biconical Antenna	SCHWARZBECK	VHBB 9124	301	30MHz ~ 200MHz	Jul. 28, 2004	Radiation (03CH03-HY)
12	Log Antenna	SCHWARZBECK	VUSLP 9111	221	200MHz ~ 1GHz	Jul. 28, 2004	Radiation (03CH03-HY)
13	Horn Antenna	EMCO	3115	6741	1GHz ~ 18GHz	Apr. 22, 2005	Radiation (03CH03-HY)
14	RF Cable-R03m	Jye Bao	RG142	CB021	30MHz ~ 1GHz	Feb. 22, 2005	Radiation (03CH03-HY)
15	RF Cable-HIGH	SUHNER	SUCOFLEX 106	03CH03-HY	1GHz ~ 40GHz	Dec.01, 2004	Radiation (03CH03-HY)
16	Turn Table	HD	DS 420	420/650/00	0 ~ 360 degree	N/A	Radiation (03CH03-HY)
17	Antenna Mast	HD	MA 240	240/560/00	1 m - 4 m	N/A	Radiation (03CH03-HY)

※ Calibration Interval of instruments listed above is one year.



Items	Instrument	Manufacturer	Model No.	Serial No.	Characteristics	Calibration Date	Remark
18	Amplifier	MITEQ	AMF-6F-260400	923364	26.5GHz ~ 40GHz	Jan. 05, 2004*	Radiation (03CH03-HY)
19	Loop Antenna	R&S	HFH2-Z2	860004/001	9kHz ~ 30MHz	May 24, 2004*	Radiation (03CH03-HY)
20	Horn Antenna	SCHWARZBECK	BBHA9170	BBHA9170154	15GHz ~ 40GHz	Jun. 09, 2004*	Radiation (03CH03-HY)

※ Calibration Interval of instruments listed above is two year.



Items	Instrument	Manufacturer	Model No.	Serial No.	Characteristics	Calibration Date	Remark
21	Spectrum analyzer	R&S	FSP30	100023	9kHz ~ 30GHz	Aug. 02, 2004	Conducted (TH01-HY)
22	Power meter	R&S	NRVS	100444	DC ~ 40GHz	Jul. 06, 2005	Conducted (TH01-HY)
23	Power sensor	R&S	NRV-Z55	100049	DC ~ 40GHz	Jul. 06, 2005	Conducted (TH01-HY)
24	Power Sensor	R&S	NRV-Z32	100057	30MHz ~ 6GHz	Apr. 28, 2005	Conducted (TH01-HY)
25	AC power source	HPC	HPA-500W	HPA-9100024	AC 0 ~ 300V	Apr. 21, 2005	Conducted (TH01-HY)
26	DC power source	G.W.	GPC-6030D	C671845	DC 1V ~ 60V	Nov. 28, 2004	Conducted (TH01-HY)
27	Temp. and Humidity Chamber	KSON	THS-C3L	612	N/A	Oct. 01, 2004	Conducted (TH01-HY)
28	RF CABLE-1m	Jye Bao	RG142	CB034-1m	20MHz ~ 7GHz	Jan. 01, 2005	Conducted (TH01-HY)
29	RF CABLE-2m	Jye Bao	RG142	CB035-2m	20MHz ~ 1GHz	Jan. 01, 2005	Conducted (TH01-HY)
30	Oscilloscope	Tektronix	TDS1012	CO38515	100MHz / 1GS/s	Apr. 15, 2005	Conducted (TH01-HY)

※ Calibration Interval of instruments listed above is one year.



## 7. Company Profile

SPORTON Lab. was established in 1986 with one shielded room: the first private EMI test facility, offering local manufacturers an alternative EMI test facility apart from ERSO. In 1988, one 3M and 10M/3M open area test site were setup and also obtained official accreditation from FCC, VCCI and NEMKO. In 1993, a Safety laboratory was founded and obtained accreditation from UL of USA, CSA of Canada and TUV (Rhineland & PS) of Germany. In 1995, one EMC lab, including EMI and EMS test facilities was setup. In 1997, SPORTON Group has provided financial expense to relocate the headquarter to Orient Scientific Park in Taipei Hsien to offer more comprehensive, more qualified and better service to local suppliers and manufactures. In 1999, Safety Group and Component Group were setup. In 2001, SPORTON has established 3M/10M chamber in Hwa Ya Technology Park.

### 7.1. Certificate of Accreditation

Taiwan	BSMI, CNLA, DGT
USA	FCC, NVLAP, UL
EU	Nemko, TUV
Japan	VCCI
Canada	Industry Canada

### 7.2. Test Location

SHIJR	ADD : 6Fl., No. 106, Sec. 1, Shintai 5th Rd., Shijr City, Taipei, Taiwan 221, R.O.C. TEL : 02-2696-2468 FAX : 02-2696-2255
HWA YA	ADD : No. 52, Hwa Ya 1st Rd., Hwa Ya Technology Park, Kwei-Shan Hsiang, Tao Yuan Hsien, Taiwan, R.O.C. TEL : 03-327-3456 FAX : 03-318-0055
LINKOU	ADD : No. 30-2, Dingfu Tsuen, Linkou Shiang, Taipei, Taiwan 244, R.O.C TEL : 02-2601-1640 FAX : 02-2601-1695
DUNGHU	ADD : No. 3, Lane 238, Kangle St., Neihu Chiu, Taipei, Taiwan 114, R.O.C. TEL : 02-2631-4739 FAX : 02-2631-9740
JUNGHE	ADD : 7Fl., No. 758, Jungjeng Rd., Junghe City, Taipei, Taiwan 235, R.O.C. TEL : 02-8227-2020 FAX : 02-8227-2626
NEIHU	ADD : 4Fl., No. 339, Hsin Hu 2 <sup>nd</sup> Rd., Taipei 114, Taiwan, R.O.C. TEL : 02-2794-8886 FAX : 02-2794-9777

## 8. CNLA Certificate of Accreditation

Test Lab. : Sporton International Inc.  
Accreditation Number : 1190  
Originally Accredited : 2003/12/15  
Effective Period : 2003/12/15~2006/12/14  
Accredited Scope : 47 CFR FCC Part 15 Subpart C (9kHz~40GHz)

Taiwan Accreditation Foundation Chinese National Laboratory Accreditation Certificate of Accreditation	
Accreditation Criteria:	ISO 17025
Accreditation Number:	1190
Organization/Laboratory:	EMC & Wireless Communications Laboratory, Sporton International Inc.
Originally Accredited:	December 15, 2003
Effective Period:	December 15, 2003 To December 14, 2006
Accredited Scope:	Electrical Testing Field, 7 items, details shown in the following pages.
Specific Accreditation Program:	Recognition and Approval of Designated Laboratory for Commodities Inspection

  
President, Taiwan Accreditation Foundation  
Date: July 19, 2004

(This document is invalid unless accompanied by all 4 pages)

CNLA-ZL03191E Page 1 of 4