

IC-3011DP
Quick Installation Guide
(QIG)
V1.0

2015-11

Table of Contents

I. Product Information	3
I-1. Package Content	3
I-2. LED Status(Gateway).....	3
I-3. LED Status(Camera)	4
I-4. Pairing	5
I-5. Reset	6
II. Gateway Installation.....	7
III. Camera Installation	8-9
IV. Camera Setup – Using Mobile APP	10-11
V. Camera Setup – Mobile APP Instruction	12
VI. FCC Statement.....	13

Package Contents

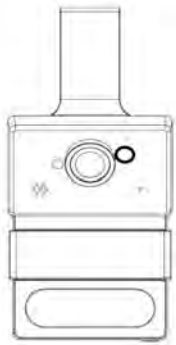

Camera

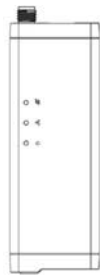

Gateway

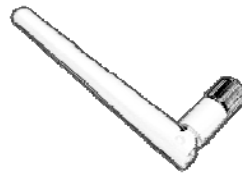

Antenna

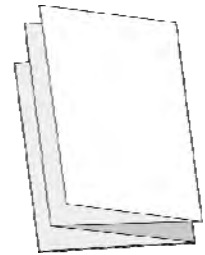

QIG



Power Adapter

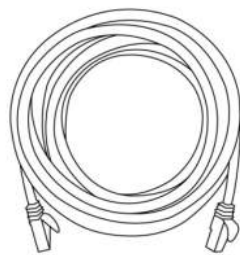

Ethernet Cable

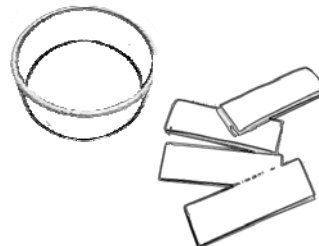

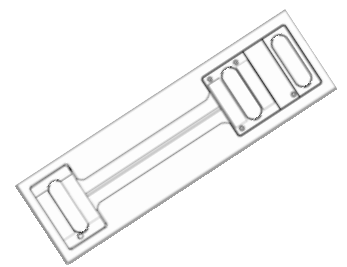

Velcro & Silicon Band



Hook Template

LED Status(Gateway)

LED Color	LED Status	Description
Green 	Quick Flashing	Paired camera data has been cleared.
	Quick Flashing	The gateway is restarting.
	Slow Flashing	Pairing is activating.
Green 	On	The gateway is connected to the local network.
	Quick Flashing	The gateway is transferring data.
Orange 	On	The gateway is connecting to internet.
	Slow Flashing	The gateway is not connected to internet.

LED Status(Camera)

LED Color	LED Status	Description
Green (Status)	On	The camera is in use.
	Slow Flashing	Pairing is activating.
Orange (Status)	Quick Flashing	Success pairing (Blinks for 5 seconds).
	Slow Flashing	PIR event trigger.
Red 	Slow Flashing	Battery low power warning.(Figure 1)

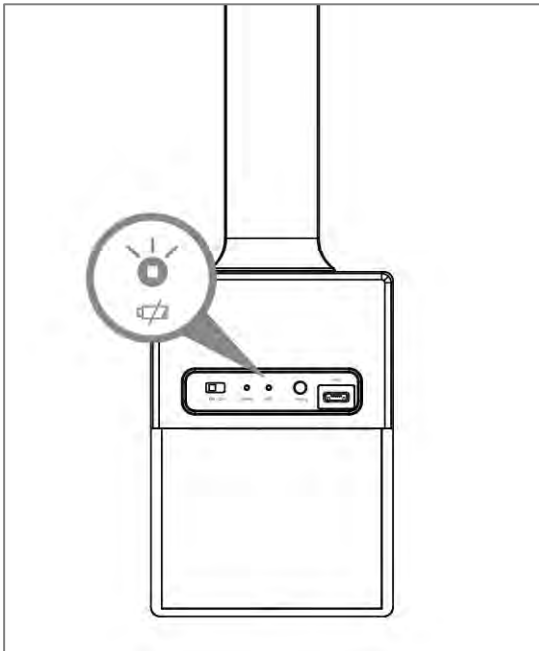

(Figure 1, Battery low power indication)

Pairing

The “Pair” button is a quick and easy alternative to establish a secure wireless connection between your camera and gateway.

- 1.** Press and hold the Pair button on your **gateway** for 2 seconds to activate pairing.

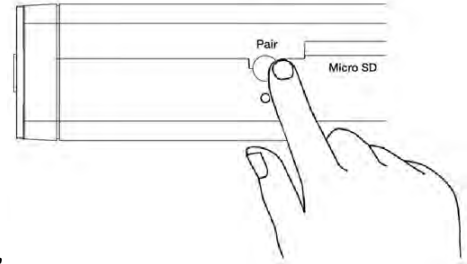

The pair button for gateway

- ***Hold 2-4 seconds for pairing to activate.***
- ***Hold more than 5 seconds to clean all paired camera data.***

- 2.** Within 30 seconds, press the “Pair” button on the camera for 1 – 2 seconds to activate pairing. The Status LED will **flash quickly** into “orange” which indicates that pairing is successful.

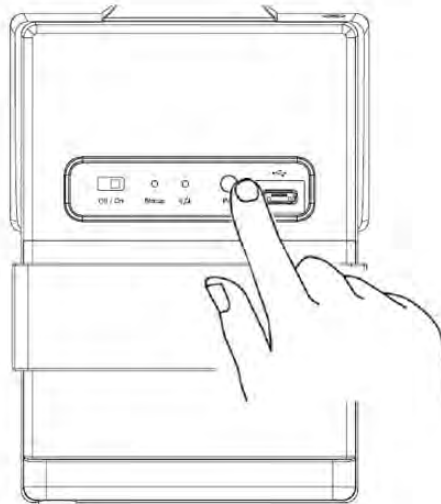

One gateway can pair up to 4 cameras.

Reset

If you experience problems with your network camera, you can reset the camera back to its factory default settings. This resets **all** settings back to default.

1. Press and hold the Reset button found on the back panel for at least 10 seconds. Release the button when the  LED is **flashing quickly into "green"**.

2. Wait for the gateway to restart.

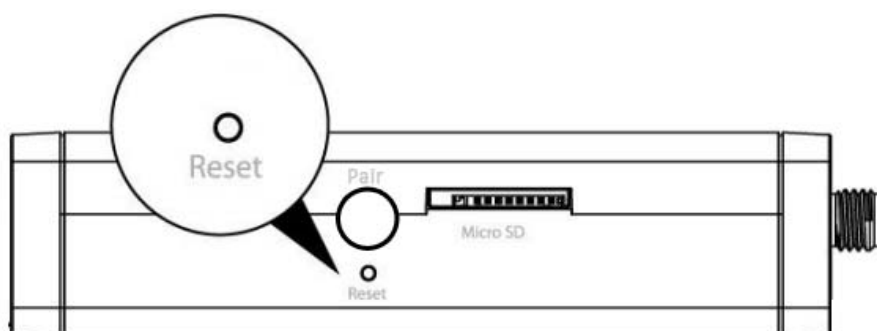

Gateway Installation

Follow the instructions below to ensure your camera is properly connected and ready for setup.

1. Screw on the included antenna to the product's gateway unit.

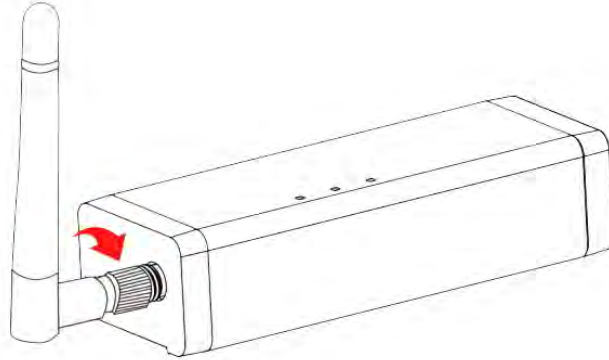

2. Connect the power adapter to the gateway and to a power supply.

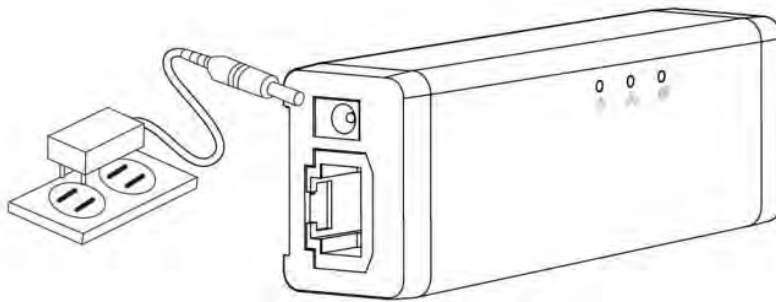

3. Use an Ethernet cable to connect the gateway's LAN port to a Wireless AP/ Router's LAN port, as shown below.

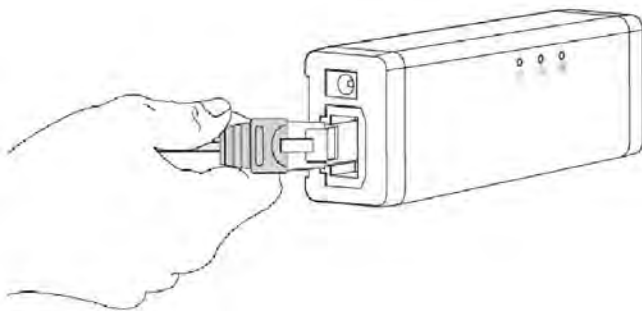

For cloud service, ensure your Wireless AP/ Router can access to the internet.

4. Wait a moment for the camera to power on. The camera is ready when the **Power** LED of the camera displays **on** or **flashing**. Please refer to **Gateway LED Status on Page.3**.

Camera Installation

1. For camera power supply, you can choose battery powered or USB power bank, as shown below.(Figure A and Figure B)

 For better performance, please use Alkaline/rechargeable batteries. (Heavy duty is not recommended!)

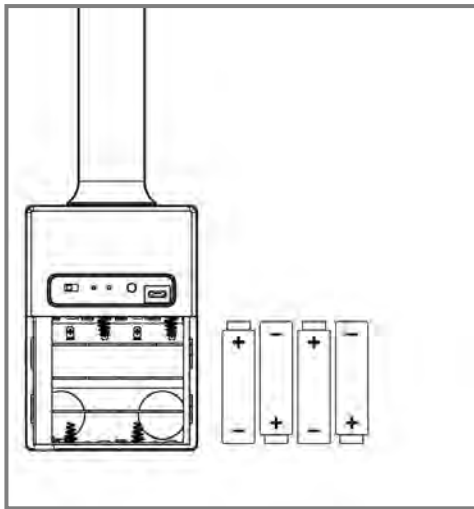

(Figure A, Battery installation)



 Please turn the switch "off" before plugging the USB power source.

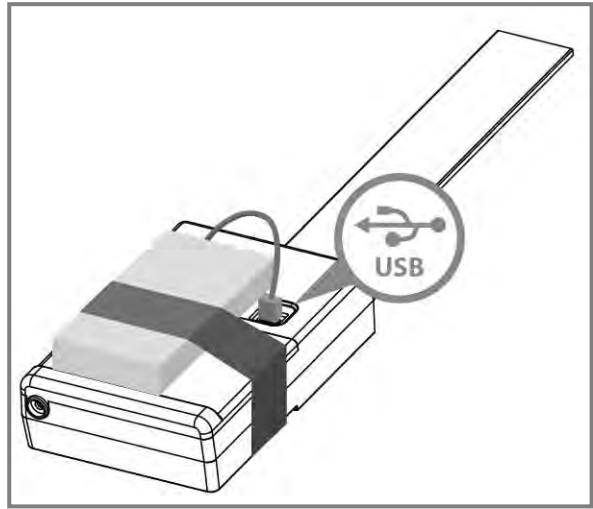

(Figure B, USB Power bank installation)

2. The door gap must be more than 2.5mm as shown below.

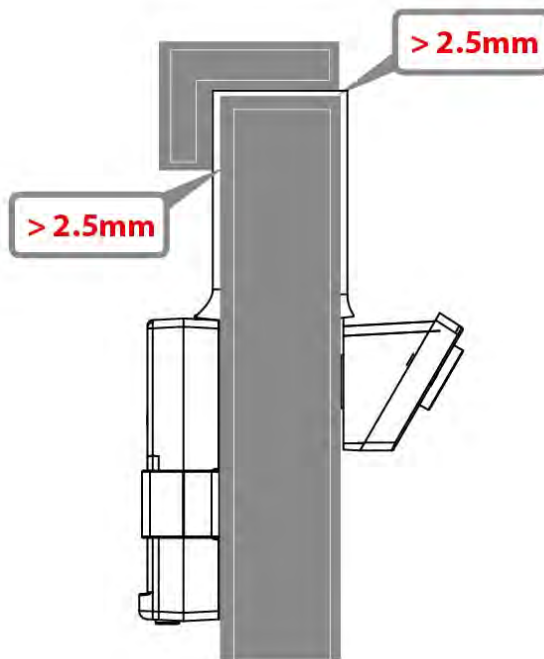

Camera Installation

3. Hook on the metal door.

With 5 strong magnets, you can easily install and adjust on a metal door without any tools.

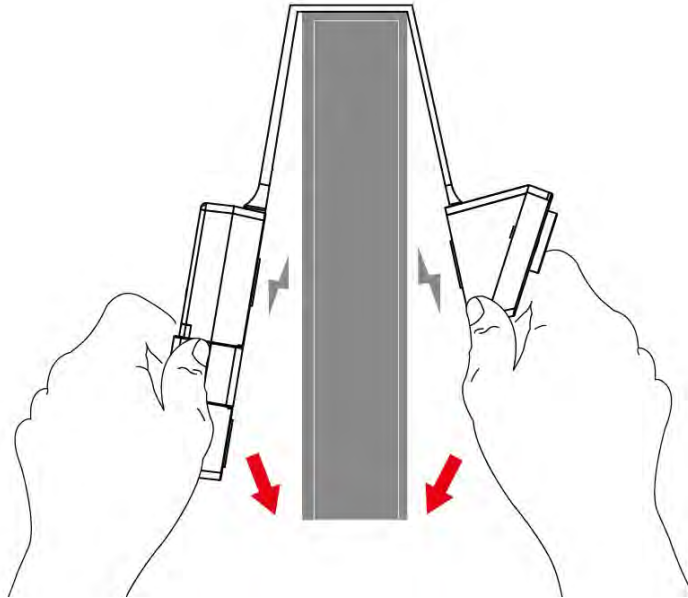

4. Hook on the nonmetal door

Fix and stick with the “Hook Template” and the “Velcro” on the nonmetal door as shown below for the “assembling diagram”.

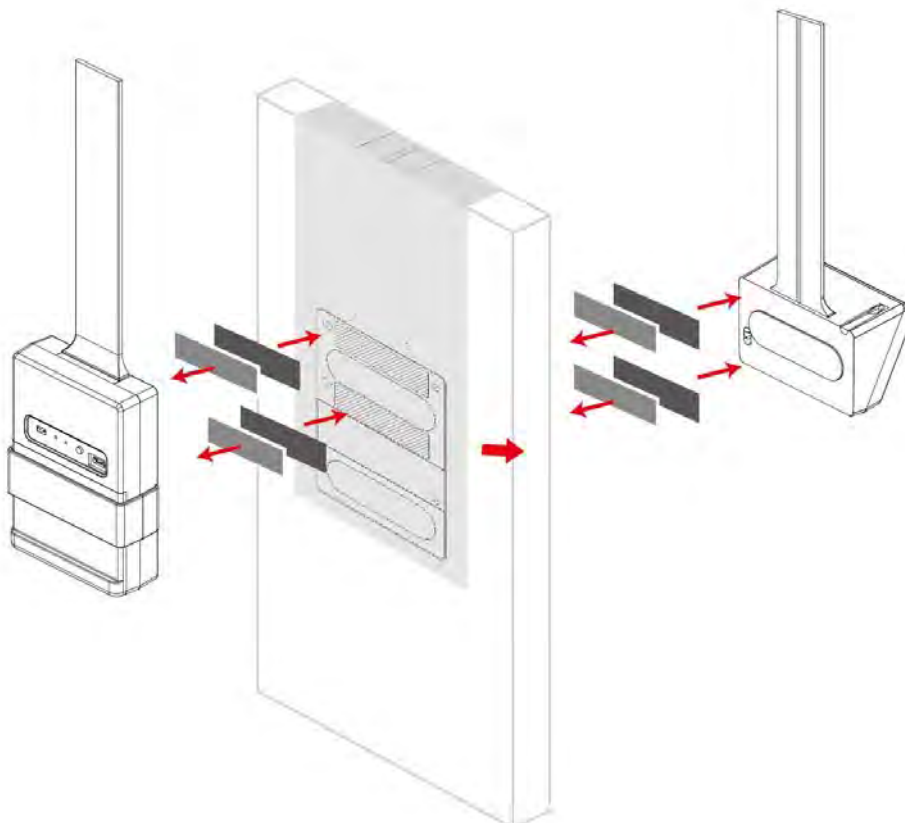

Camera Setup – Using Mobile App

1. Use a smartphone or tablet to search, download and install the AcelinkView II app from Google Play or the Apple App Store.



2. For iOS/Android users, go to Wi-Fi settings and connect to your Wireless AP/ Router’s SSID (ensure the camera gateway connected via LAN, see **Step.3 on Page.7**), before opening the AcelinkView II app.

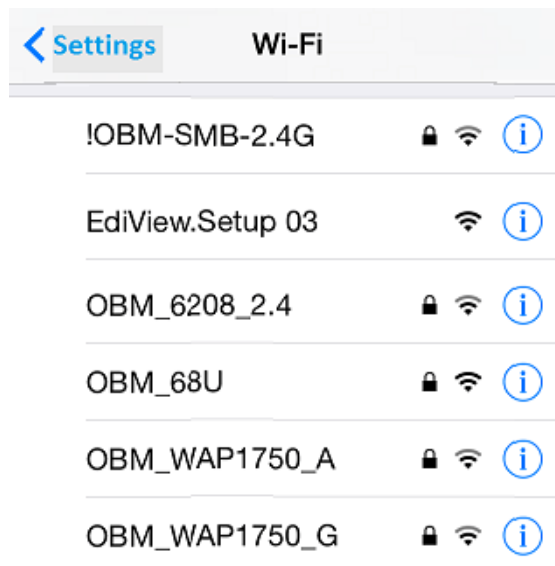

Camera Setup – Using Mobile App

3. First time running the APP, click “+” icon to add camera (Figure C) and you will see the camera IP address on the list which has connected on your local network(Figure D).



(Figure C, add camera)

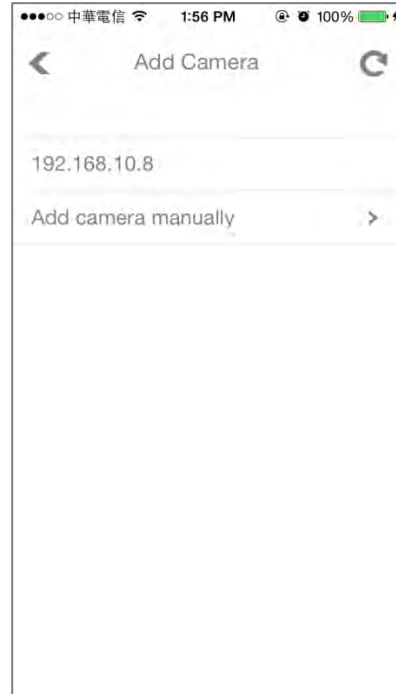

(Figure D, camera list)

4. Enter the password (The default password is 1234), it will pop up a message if added successfully, as shown below.

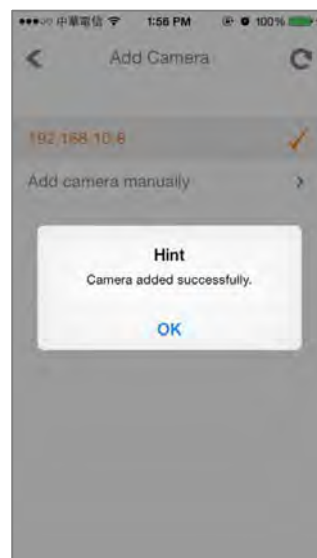
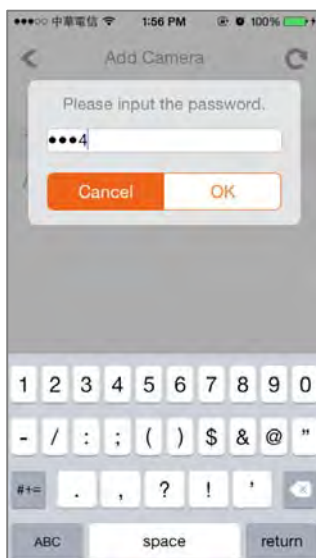

Reminder: Outdoor and other area where the camera is exposed to special lighting will have some color shifting. This image is very common and perfectly normal. It's due to the special design of our camera lens.

Camera Setup –Mobile App Instruction

- 1.** Single click : Show/Hide quick buttons, camera name and other settings.
 Double click : Zoom in/ out video image.

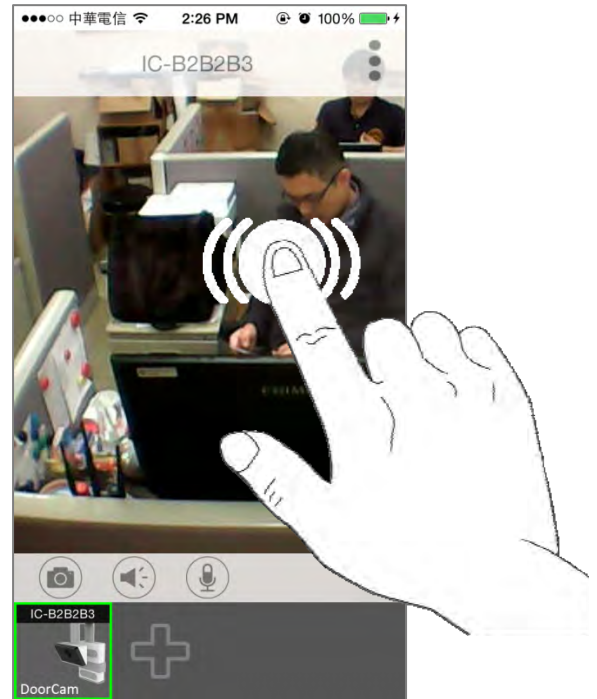
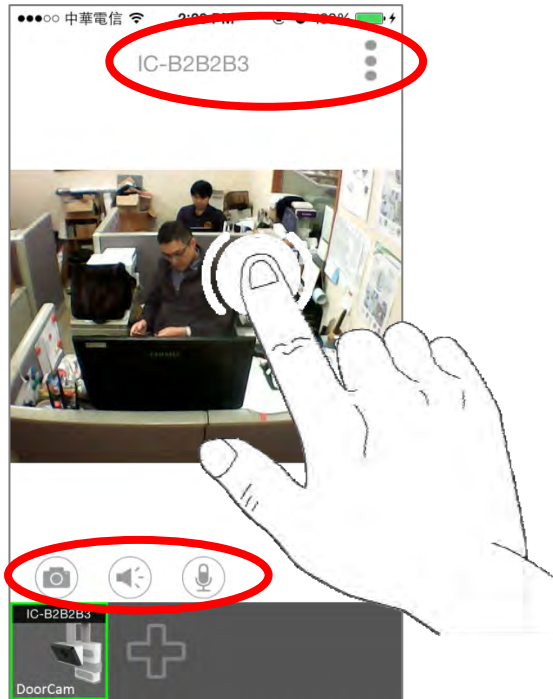

- 2.**  Camera Mic On (Hear from the Camera)

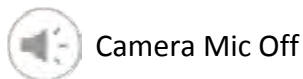

-  Camera Speaker On (Talk to the Camera)

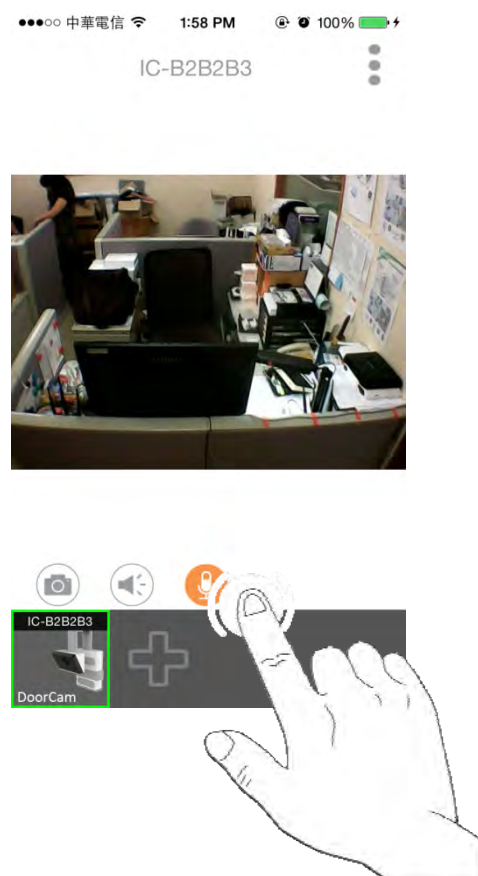
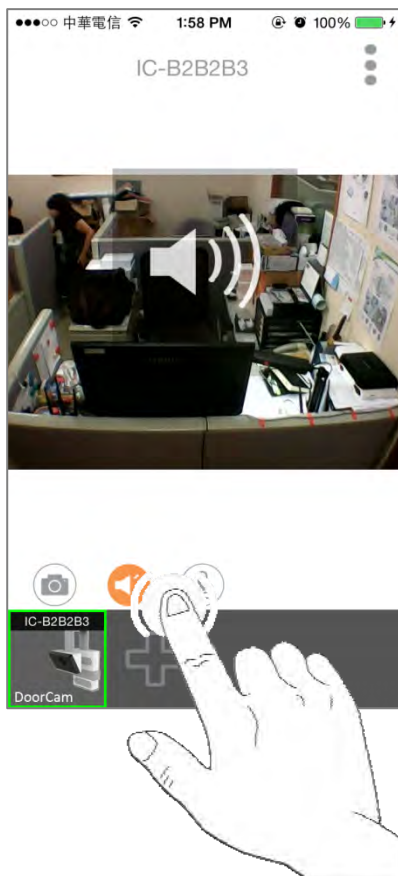

Federal Communication Commission Interference Statement

This equipment has been tested and found to comply with the limits for a Class B digital device, pursuant to Part 15 of FCC Rules. These limits are designed to provide reasonable protection against harmful interference in a residential installation. This equipment generates, uses, and can radiate radio frequency energy and, if not installed and used in accordance with the instructions, may cause harmful interference to radio communications. However, there is no guarantee that interference will not occur in a particular installation. If this equipment does cause harmful interference to radio or television reception, which can be determined by turning the equipment off and on, the user is encouraged to try to correct the interference by one or more of the following measures:

1. Reorient or relocate the receiving antenna.
2. Increase the separation between the equipment and receiver.
3. Connect the equipment into an outlet on a circuit different from that to which the receiver is connected.
4. Consult the dealer or an experienced radio technician for help.

FCC Caution

Any changes or modifications not expressly approved by the party responsible for compliance could void the authority to operate equipment.

This device complies with Part 15 of the FCC Rules. Operation is subject to the following two conditions: (1) this device may not cause harmful interference, and (2) this device must accept any interference received, including interference that may cause undesired operation.

FCC Radiation Exposure Statement:

This equipment complies with FCC radiation exposure limits set forth for an uncontrolled environment. This equipment should be installed and operated with minimum distance 20cm between the radiator & your body.

This device and its antenna(s) must not be co-located or operating in conjunction with any other antenna or transmitter.

R&TTE Compliance Statement

This equipment complies with all the requirements of DIRECTIVE 1999/5/EC OF THE EUROPEAN PARLIAMENT AND THE COUNCIL of March 9, 1999 on radio equipment and telecommunication terminal equipment and the mutual recognition of their conformity (R&TTE). The R&TTE Directive repeals and replaces in the directive 98/13/EEC (Telecommunications Terminal Equipment and Satellite Earth Station Equipment) As of April 8, 2000.

Safety

This equipment is designed with the utmost care for the safety of those who install and use it. However, special attention must be paid to the dangers of electric shock and static electricity when working with electrical equipment. All guidelines of this and of the computer manufacture must therefore be allowed at all times to ensure the safe use of the equipment.

EU Countries Intended for Use

The ETSI version of this device is intended for home and office use in Austria, Belgium, Bulgaria, Cyprus, Czech, Denmark, Estonia, Finland, France, Germany, Greece, Hungary, Ireland, Italy, Latvia, Lithuania, Luxembourg, Malta, Netherlands, Poland, Portugal, Romania, Slovakia, Slovenia, Spain, Sweden, Turkey, and United Kingdom. The ETSI version of this device is also authorized for use in EFTA member states: Iceland, Liechtenstein, Norway, and Switzerland.

EU Countries Not Intended for Use

None