



Product Service

**Choose certainty.
Add value.**

Report On

Specific Absorption Rate Testing of the
Option NV
GE0421 Globetrotter Express Card

FCC ID: NCMOGE0421

Document 75903886 Report 01 Issue 3

July 2008



Product Service

TUV Product Service Ltd, Octagon House, Concorde Way, Segensworth North,
Fareham, Hampshire, United Kingdom, PO15 5RL
Tel: +44 (0) 1489 558100. Website: www.tuvps.co.uk

REPORT ON

Specific Absorption Rate Testing of the
Option NV
GE0421 Globetrotter Express Card

Document 75903886 Report 01 Issue 3

FCC ID: NCMOGE0421

July 2008

PREPARED FOR

Option NV
Gaston Geenslaan 14
B-3001
Leuven
Belgium

PREPARED BY

A handwritten signature in black ink, appearing to read 'A Miller', written over a horizontal line.

A Miller
Principal Engineer

APPROVED BY

A handwritten signature in black ink, appearing to read 'M Jenkins', written over a horizontal line.

M Jenkins
Authorised Signatory

DATED

11 July 2008

This report has been up-issued to Issue 3 to correct minor typographical errors.



CONTENTS

Section	Page No
1	REPORT SUMMARY
1.1	Status 4
1.2	Summary..... 6
1.3	Output Power Measurements 9
1.4	Test Results Summary..... 11
2	TEST DETAILS
2.1	SAR Measurement System..... 16
	2.1.1 Robot System Specification
	2.1.2 Probe and Amplifier Specification
	2.1.3 SAR Measurement Procedure
2.2	SAR Distributions (Area Scans – 2D) 21
3	TEST EQUIPMENT
3.1	Test Equipment..... 48
3.2	Test Software 48
3.3	Dielectric Properties of Simulant Liquids 49
3.4	Test Conditions 50
3.5	Measurement Uncertainty..... 51
4	PHOTOGRAPHS
4.1	Test Positional Photographs..... 53
4.2	Photographs of Equipment Under Test (EUT)..... 55
5	ACCREDITATION, DISCLAIMERS AND COPYRIGHT
5.1	Accreditation, Disclaimers and Copyright 59
ANNEX A	Probe Calibration InformationA.2



SECTION 1

REPORT SUMMARY

Specific Absorption Rate Testing of the Option NV
GE0421 Globetrotter Express Card

Max 1g SAR (W/kg)	0.794
<p>The maximum 1g volume averaged SAR level measured for all the tests performed did not exceed the limits for General Population/Uncontrolled Exposure (W/kg) Partial Body of 1.6 W/kg. Level defined in Supplement C (Edition 01-01) to OET Bulletin 65 (97-01). This device is compliant with CFR47§2.1093.</p>	



1.1 STATUS

MANUFACTURING DESCRIPTION	GE0421 Globetrotter Express Card
STATUS OF TEST	Specific Absorption Rate Testing
APPLICANT	Option NV
POWER CLASS	GSM 835 MHz Class 4 GSM 900 MHz Class 4 DCS 1800 MHz Class 1 PCS 1900 MHz Class 1
GPRS CLASS	Class B
GPRS MULTI-SLOT CLASS	GSM850 – Class 10 (4Dn; 2Up; Sum5) PCS1900 – Class12 (4Dn; 4Up; Sum5)
WCDMA FREQUENCY BAND	FDD1 (1922.4 to 1977.6 MHz) FDD2 (1852.4 to 1907.6 MHz) FDD8 (882.4 to 912.6 MHz)
WCDMA POWER CLASS	FDD I/II/VIII Power Class 3 (+24dBm)
MANUFACTURER	Option NV
TYPE OR MODEL NUMBER	GE0421
HARDWARE VERSION	3.1
SOFTWARE VERSION	1.2.4.0
IMEI NUMBER	004401440982508
SERIAL NUMBER	PV3485KOLM
HOST 1 MANUFACTURER & MODEL	HP Compaq nc 6320
HOST 1 COUNTRY OF MANUFACTURE	China
HOST 2 MANUFACTURER & MODEL	Sony Vaio VGN-TZ31MN/N
HOST 2 COUNTRY OF MANUFACTURE	China
POWER SUPPLY	Laptop used (Host 1 and Host 2 detailed above)

TEST SPECIFICATIONS:

1. FCC Publication Supplement C (Edition 01-01) to OET Bulletin 65 (Edition 97-01): Evaluating Compliance with FCC Guidelines for Human Exposure to Radiofrequency Electromagnetic Fields – Additional Information for evaluating Compliance of Mobile and Portable Devices with FCC Limits for Human Exposure to Radiofrequency Emissions
2. IEEE 1528 – 2003: Recommended Practice for Determining the Peak Spatial-Average Specific Absorption Rate (SAR) in the Human Body Due to Wireless Communications Devices: Experimental Techniques.
3. IEEE Std C95.1-2005: IEEE Standard for Safety Levels with Respect to Human Exposure to Radio Frequency Electromagnetic Fields, 3kHz to 300 GHz, Inst. of Electrical and Electronics Engineers, Inc.,2005.
4. ICNIRP: Guidelines for Limiting Exposure to Time-varying Electric, Magnetic, and Electromagnetic Fields (up to 300 GHz), In: Health Physics, Vol. 74, No. 4, 494-522, 1998.
5. ETSI TS 134 121-1 V7.4.0, Universal Mobile Telecommunications System (UMTS) ; User Equipment (UE) conformance specification; Radio transmission and reception (FDD)



Product Service

1.1 STATUS - Continued

REFERENCES:

6. KDB 941125 D01 SAR test for 3G devices v02 - FCC OET SAR Measurement Procedures for 3G Devices – CDMA 2000 / Ev-DO – WCDMA / HSDPA / HSPA – October 2007
7. KDB 447498 D01 Mobile Portable RF Exposure v03r01 – Mobile and Portable Device RF Exposure Procedures and Equipment Authorisation Policies – May 12, 2008

TUV REGISTRATION NUMBER:	75903886
RECEIPT OF TEST SAMPLES:	30 June 2008
START OF TEST:	30 June 2008
FINISH OF TEST:	03 July 2008



1.2 SUMMARY

The device supplied for Specific Absorption Rate (SAR) testing was the Option NV GE0421 Globetrotter Express Card, designed for worldwide connectivity by multi-standard (HSUPA, HSDPA, UMTS, EDGE and GPRS) and multi-band support. This device is a production sample. The card supports 850/900/1800/1900 MHz EDGE/GSM as well as WCDMA 900/1900/2100 MHz HSUPA/HSDPA/UMTS. The UE Power class is 3 and the device supports HSDPA category 8 and HSUPA Category 5. The device supports EGPRS class 12.

The Option NV GE0421 Globetrotter Express Card was only tested for 850/1900 MHz EDGE/GSM as well as WCDMA 1900 MHz HSUPA / HSDPA / UMTS at this time. The reasons are as follows:

- a) The 900/1800 MHz EDGE/GSM bands and the WCDMA 900/2100 MHz HSUPA / HSDPA / UMTS bands are not supported in North America and so these bands are not relevant. These bands have been tested and the results are presented in a separate test report. TUV Product Service Document 75903886 Report 02 refers.

The Option NV GE0421 Globetrotter Express Card has an integral antenna. The Option NV GE0421 was tested in two host laptops. The first host laptop, HP Compaq nc 6320 was used to carry out the test of the Card with an adapter (PCI to PCMCIA adapter) and a separation distance of 10mm was measured from the card to the bottom of the flat phantom. The second host laptop, Sony Vaio VGN-TZ31MN/N was used to carry out the test of the Card inserted directly to the host and a separation distance of 10mm was measured from the card to the bottom of the flat phantom. Two separate laptops were used because no single laptop could be utilised which provided the slots to support the card in adapter tests as well as the card without adapter tests, whilst maintaining a separation distance less than 10mm as required by Section 2)(b)(i)(3) of KDB 447498 D01 Mobile Portable RF Exposure v03r01.

Output power measurements were made in accordance to the 3GPP 134 121-1 standard. The highest output power reading for HSDPA and HSUPA for the FDD II band was identified and testing was performed in the highest output power configurations. The Rohde & Schwarz CMU200 Radio Communications Test Set which is capable of measuring W-CDMA/HSDPA terminals was used to establish the required test configuration for the GE0421 Globetrotter Express Card as per the FCC OET SAR Measurement Procedures for 3G Devices.

Body SAR GPRS tests were performed in the timeslot configuration which was found to produce the highest SAR levels, taking into consideration power reduction in certain bands/modes. The Globetrotter Express Card is a release 6 HSDPA data device and as such the appropriate procedures were followed for body SAR measurements. Body SAR measurements were performed in 12.2kbps RMC in test loop mode 1. The HSDPA body SAR measurements were made using an FRC with H-set 1 and a 12.2kbps RMC configured in test loop mode 1. Then once testing was completed in top, middle and bottom channels, the worst case configuration was used and SAR for HSDPA / HSUPA was measured with HS-DPCCH, E-DPCCH and E-DPDCH all enabled with 12.2kbps RMC with transmit power control set to all 1's.



SAR testing on the body was conducted on the FDD II band in HSDPA Sub-test 2 mode and HSUPA Sub-test 5 mode with the HP Compaq nc 6320 host laptop being used. The rear of the laptop was in contact with the bottom of the flat phantom. SAR testing was also conducted on the FDD II band in HSDPA Sub-test 2 mode and HSUPA Sub-test 5 mode with the Sony Vaio VGN-TZ31MN/N host laptop being used. The rear of the laptop was in contact with the bottom of the flat phantom.

The UE operates within the 3GPP standards defining required UMTS spreading factors.

- The DPCCH spreading factor is 256 per 3GPP TS 25.213 section 4.3.1.2.1.
- The DPDCH spreading factor is dependent on number of DPDCH channels and data range. For a single channel the spreading factor can range from 4 to 256. For more than one DPDCH channel the spreading factor is 4. Further details are defined by 3GPP in TS 25.213 section 4.3.1.2.1.
- HS-DPCCH spreading factor is 256. Further details can be found in 3GPP TS 25.213 section 4.3.1.2.2.

CHANNEL PARAMETERS FOR HSDPA

Fixed Reference Channel H-Set 1

Parameter	Unit	Value	
Nominal Avg. Inf. Bit Rate	kbps	534	777
Inter-TTI Distance	TTI's	3	3
Number of HARQ Processes	Processes	2	2
Information Bit Payload (N_{INF})	Bits	3202	4664
MAC-d PDU size	Bits	336	336
Number Code Blocks	Blocks	1	1
Binary Channel Bits Per TTI	Bits	4800	7680
Total Available SML's in UE	SML's	19200	19200
Number of SML's per HARQ Proc.	SML's	9600	9600
Coding Rate		0.67	0.61
Number of Physical Channel Codes	Codes	5	4
Modulation		QPSK	16QAM
Note: The HS-DSCH shall be transmitted continuously with constant power but only every third TTI shall be allocated to the UE under test			

β values for transmitter characteristics tests with HS-DPCCH and E-DCH

Sub-test	β_c	β_d	β_d (SF)	β_c/β_d	β_{hs} (Note 1)	β_{ec}	β_{ed} (Note 5) (Note 6)	β_{ed} (SF)	β_{ed} (Codes)	CM (dB) (Note 2)	MPR (dB) (Note 2)	AG Index (Note 6)	E-TFCI
1	11/15 (Note 3)	15/15 (Note 3)	64	11/15 (Note 3)	22/15	209/225	1309/225	4	1	1.0	0.0	20	75
2	6 / 15	15/15	64	6/15	12/15	12 / 15	9 4 / 7 5	4	1	3.0	2.0	12	67
3	15/15	9 / 15	64	15/9	30/15	30 / 15	β_{ed1} : 47/15 β_{ed2} : 47/15	4	2	2.0	1.0	15	92
4	2 / 15	15/15	64	2/15	4 / 15	2 / 15	5 6 / 7 5	4	1	3.0	2.0	17	71
5	15/15 (Note 4)	15/15 (Note 4)	64	15/15 (Note 4)	30/15	24 / 15	1 3 4 / 1 5	4	1	1.0	0.0	21	81

Note 1: Δ_{ACK} , Δ_{NACK} and $\Delta_{CQI} = 30/15$ with $\beta_{hs} = 30/15 * \beta_c$.

Note 2: CM = 1 for $\beta_c/\beta_d = 12/15$, $\beta_{hs}/\beta_c = 24/15$. For all other combinations of DPDCH, DPCCH, HS- DPCCH, E-DP

Note 3: For subtest 1 the β_c/β_d ratio of 11/15 for the TFC during the measurement period (TF1, TF0) is achieved by

Note 4: For subtest 5 the β_c/β_d ratio of 15/15 for the TFC during the measurement period (TF1, TF0) is achieved by

Note 5: In case of testing by UE using E-DPDCH Physical Layer category 1, Sub-test 3 is omitted according to TS

Note 6: β_{ed} can not be set directly, it is set by Absolute Grant Value.



On completion of testing, the test configuration with the highest 1-g SAR for each host platform was used to determine if additional SAR evaluation was required due to enhanced energy coupling at increased separation in accordance with the procedure described in Section 2(b)(ii) of KDB 447498 D01 Mobile Portable RF Exposure v03r01.

The Flat Phantom dimensions were 210mm x 210mm x 210mm with a sidewall thickness of 2.00mm. The phantom was filled to a minimum depth of 150mm with the appropriate Body simulant liquid. The dielectric properties were in accordance with the requirements for the dielectric properties specified in Supplement C (Edition 01-01) to OET Bulletin 65 (Edition 97-01).

Included in this report are descriptions of the test method; the equipment used and an analysis of the test uncertainties applicable and diagrams indicating the locations of maximum SAR for each test position along with photographs indicating the positioning of the module with respect to the body as appropriate.

The maximum 1g volume averaged SAR level measured for all the tests performed did not exceed the limits for General Population/Uncontrolled Exposure (W/kg) Partial Body of 1.6 W/kg. Level defined in Supplement C (Edition 01-01) to OET Bulletin 65 (97-01).



1.3 RF Power Output

3GPP TS 51.010-1 V7.8.0, Digital cellular telecommunications system (Phase 2+); Mobile Station (MS) conformance specification; Part 1: Conformance specification (Release 7)

ETSI TS 134 121-1 V7.4.0, Universal Mobile Telecommunications System (UMTS); User Equipment (UE) conformance specification; Radio transmission and reception (FDD).

METHOD

The EUT was controlled via the Rohde & Schwarz CMU200 Radio Communications Test Set which was capable of providing the required modes of modulation and sub-sets. The radiated ERP / EIRP power measurements are presented below.

RESULTS

Band II						
Mode	Frequency (MHz)	Raw (dBm)	Sub (dBm)	Gain (dB)	Result (dBm)	Result (W)
CS	1852.4	-22.8	15.5	8.4	23.9	0.25
	1880	-23.9	14.4	8.4	22.8	0.19
	1907.6	-22.1	15.7	8.3	24	0.25
HSDPA 1	1852.4	-22.4	15.9	8.4	24.3	0.27
	1880	-21.6	16.7	8.4	25.1	0.32
	1907.6	-21.7	16.1	8.3	24.4	0.28
HSDPA 2	1852.4	-21.6	16.7	8.4	25.1	0.32
	1880	-21.1	17.2	8.4	25.6	0.36
	1907.6	-21.8	16.1	8.3	24.4	0.28
HSDPA 3	1852.4	-21.3	17	8.4	25.4	0.35
	1880	-20.9	16.9	8.4	25.2	0.33
	1907.6	-21.4	16.4	8.3	24.7	0.30
HSDPA 4	1852.4	-21.5	16.8	8.4	25.2	0.33
	1880	-21.2	17.1	8.4	25.5	0.35
	1907.6	-21.1	16.7	8.3	25	0.32
HSUPA 1	1852.4	-21.3	17	8.4	25.4	0.35
	1880	-20.9	17.4	8.4	25.8	0.38
	1907.6	-21.4	16.4	8.3	24.7	0.30
HSUPA 2	1852.4	-21.5	16.8	8.4	25.2	0.33
	1880	-21.1	17.2	8.4	25.6	0.36
	1907.6	-21.3	16.7	8.3	25	0.32
HSUPA 3	1852.4	-21.2	17.1	8.4	25.5	0.35
	1880	-20.7	17.6	8.4	26	0.40
	1907.6	-21.3	16.5	8.3	24.8	0.30
HSUPA 4	1852.4	-22.1	16.2	8.4	24.6	0.29
	1880	-20.7	17.6	8.4	26	0.40
	1907.6	-21.7	16.1	8.3	24.4	0.28
HSUPA 5	1852.4	-21.4	16.9	8.4	25.3	0.34
	1880	-20.3	18	8.4	26.4	0.44
	1907.6	-21.8	16	8.3	24.3	0.27

850 (ERP)						
Mode	Frequency (MHz)	Raw (dBm)	Sub (dBm)	Gain (dB d)	Result (dBm)	Result (W)
GPRS	824.2	-7.9	25.8	3.9	29.7	0.93
	836.4	-9.1	24	3.9	27.9	0.62
	848.8	-9.4	24	3.3	27.3	0.54
EGPRS	824.2	-10	23.7	3.9	27.6	0.58

1900 (EIRP)						
Mode	Frequency (MHz)	Raw (dBm)	Sub (dBm)	Gain (dB i)	Result (dBm)	Result (W)
GPRS	1850.2	-22.3	17.3	8.6	25.9	0.39
	1880	-22.4	17.6	8.6	26.2	0.42
	1909.8	-22	18	8.7	26.7	0.47
EGPRS	1909.8	-24.1	15.9	8.7	24.6	0.29



1.4 TEST RESULT SUMMARY

SYSTEM PERFORMANCE / VALIDATION CHECK RESULTS

Prior to formal testing being performed a System Check was performed in accordance with OET 65 Supplement C (Edition 01-01) [5] and the results were compared against published data in Standard IEEE 1528-2003 [4]. The following results were obtained: -

Date	Dipole Used	Frequency (MHz)	Max 1g SAR (W/kg)	Percentage Drift on Reference	Max 10g SAR (W/kg)	Percentage Drift on Reference
30/06/2008	835	844.4	10.71	-0.84%	6.99	1.26%
03/07/2008	1900	1883.6	39.93	4.80%	20.95	5.28%

*Normalised to a forward power of 1W

GSM 850 BODY Specific Absorption Rate (Maximum SAR) 1g & 10g Results for the GE0421 Globetrotter Express Card with adapter in Host Laptop: HP Compaq nc 6320

Position		Mode	Channel Number	Frequency (MHz)	Max Spot SAR (W/kg)	Max 1g SAR (W/kg)	Max 10g SAR (W/kg)	SAR Drift (%)	Area scan (Figure number)
Card Spacing From Phantom	Host Laptop Position								
10mm	0mm Rear Facing	GPRS	189	836.4	0.480	0.598	0.409	0.46	Figure 4
10mm	0mm Rear Facing	GPRS	128	824.2	0.470	0.540	0.373	6.91	Figure 5
10mm	0mm Rear Facing	GPRS	251	848.8	0.450	0.518	0.360	-1.54	Figure 6
10mm	0mm Rear Facing	EGPRS	189	836.4	0.210	0.243	0.164	-5.34	Figure 7
Limit for General Population (Uncontrolled Exposure) 1.6 W/kg (1g) & 2.0 W/kg (10g)									

GSM 850 BODY Specific Absorption Rate (Maximum SAR) 1g & 10g Results for the GE0421 Globetrotter Express Card in Host Laptop: Sony Vaio VGN-TZ31MN/N

Position		Mode	Channel Number	Frequency (MHz)	Max Spot SAR (W/kg)	Max 1g SAR (W/kg)	Max 10g SAR (W/kg)	SAR Drift (%)	Area scan (Figure number)
Card Spacing From Phantom	Host Laptop Position								
10mm	0mm Rear Facing	GPRS	189	836.4	0.610	0.757	0.480	-3.97	Figure 8
10mm	0mm Rear Facing	GPRS	128	824.2	0.660	0.794	0.533	0.04	Figure 9
10mm	0mm Rear Facing	GPRS	251	848.8	0.570	0.672	0.441	0.88	Figure 10
10mm	0mm Rear Facing	EGPRS	128	824.2	0.290	0.338	0.223	3.41	Figure 11
Limit for General Population (Uncontrolled Exposure) 1.6 W/kg (1g) & 2.0 W/kg (10g)									



PCS 1900 BODY Specific Absorption Rate (Maximum SAR) 1g & 10g Results for the GE0421 Globetrotter Express Card with adapter in Host Laptop: HP Compaq nc 6320

Position		Mode	Channel Number	Frequency (MHz)	Max Spot SAR (W/kg)	Max 1g SAR (W/kg)	Max 10g SAR (W/kg)	SAR Drift (%)	Area scan (Figure number)
Card Spacing From Phantom	Host Laptop Position								
10mm	0mm Rear Facing	GPRS	661	1880.0	0.570	0.660	0.352	-3.100	Figure 12
10mm	0mm Rear Facing	GPRS	512	1850.2	0.430	0.539	0.326	1.490	Figure 13
10mm	0mm Rear Facing	GPRS	810	1909.8	0.560	0.662	0.359	-1.400	Figure 14
10mm	0mm Rear Facing	EGPRS	810	1909.8	0.340	0.408	0.222	-0.190	Figure 15
Limit for General Population (Uncontrolled Exposure) 1.6 W/kg (1g) & 2.0 W/kg (10g)									

PCS 1900 BODY Specific Absorption Rate (Maximum SAR) 1g & 10g Results for the GE0421 Globetrotter Express Card in Host Laptop: Sony Vaio VGN-TZ31MN/N

Position		Mode	Channel Number	Frequency (MHz)	Max Spot SAR (W/kg)	Max 1g SAR (W/kg)	Max 10g SAR (W/kg)	SAR Drift (%)	Area scan (Figure number)
Card Spacing From Phantom	Host Laptop Position								
10mm	0mm Rear Facing	GPRS	661	1880.0	0.460	0.562	0.332	-2.650	Figure 16
10mm	0mm Rear Facing	GPRS	512	1850.2	0.420	0.513	0.301	-0.330	Figure 17
10mm	0mm Rear Facing	GPRS	810	1909.8	0.500	0.615	0.358	-1.990	Figure 18
10mm	0mm Rear Facing	EGPRS	810	1909.8	0.270	0.325	0.187	-0.290	Figure 19
Limit for General Population (Uncontrolled Exposure) 1.6 W/kg (1g) & 2.0 W/kg (10g)									



WCDMA FDD II BODY Specific Absorption Rate (Maximum SAR) 1g & 10g Results for the GE0421 Globetrotter Express Card with adapter in Host Laptop: HP Compaq nc 6320

Position		Mode	Channel Number	Frequency (MHz)	Max Spot SAR (W/kg)	Max 1g SAR (W/kg)	Max 10g SAR (W/kg)	SAR Drift (%)	Area scan (Figure number)
Card Spacing From Phantom	Host Laptop Position								
10mm	0mm Rear Facing	RMC TL1	9262	1852.4	0.290	0.359	0.219	2.640	Figure 20
10mm	0mm Rear Facing	RMC TL1	9400	1880.0	0.410	0.492	0.300	0.680	Figure 21
10mm	0mm Rear Facing	RMC TL1	9538	1907.6	0.250	0.315	0.187	-1.120	Figure 22
10mm	0mm Rear Facing	HSDPA Subtest 2+ RMC TL1	9400	1880.0	0.300	0.336	0.223	-4.34	Figure 23
10mm	0mm Rear Facing	HSUPA Subtest 5+ RMC TL1	9400	1880.0	0.280	0.305	0.201	1.66	Figure 24
Limit for General Population (Uncontrolled Exposure) 1.6 W/kg (1g) & 2.0 W/kg (10g)									

WCDMA FDD II BODY Specific Absorption Rate (Maximum SAR) 1g & 10g Results for the GE0421 Globetrotter Express Card in Host Laptop: Sony Vaio VGN-TZ31MN/N

Position		Mode	Channel Number	Frequency (MHz)	Max Spot SAR (W/kg)	Max 1g SAR (W/kg)	Max 10g SAR (W/kg)	SAR Drift (%)	Area scan (Figure number)
Card Spacing From Phantom	Host Laptop Position								
10mm	0mm Rear Facing	RMC TL1	9262	1852.4	0.230	0.291	0.178	0.330	Figure 25
10mm	0mm Rear Facing	RMC TL1	9400	1880.0	0.340	0.417	0.254	0.200	Figure 26
10mm	0mm Rear Facing	RMC TL1	9538	1907.6	0.240	0.303	0.189	1.260	Figure 27
10mm	0mm Rear Facing	HSDPA Subtest 2+ RMC TL1	9400	1880.0	0.310	0.383	0.223	1.400	Figure 28
10mm	0mm Rear Facing	HSUPA Subtest 5+ RMC TL1	9400	1880.0	0.320	0.394	0.240	1.730	Figure 29
Limit for General Population (Uncontrolled Exposure) 1.6 W/kg (1g) & 2.0 W/kg (10g)									



In accordance with Section 2(b)(ii) of KDB 447498 D01 Mobile Portable RF Exposure v03r01, the test configuration with the highest 1-g SAR for each host platform was evaluated as outlined in the methodology below to determine if additional SAR evaluation is required due to enhanced energy coupling at increased separation distances.

METHOD

The probe tip is positioned at the peak SAR location determined from testing with the card and adapter in host 1 and then at a distance of one half the probe tip diameter from the phantom surface, the probe is fixed at this location, the device is moved away from the phantom in 5 mm increments from the initial touching or minimum separation position. A single point SAR is measured for each of these device positions until the SAR is less than 50% of that measured at the initial position. If the highest point SAR is > 25% of that measured at the initial position, a complete 1-g SAR evaluation is required and carried out for this configuration. This method is performed again with the card directly in host 2.

RESULTS

GE0421 Globetrotter Express Card and adapter with host Laptop 1 (HP Compaq nc 6320) in GPRS1900 MS Class 12 at 1909.8MHz Channel 810

Distance (mm)	Single point SAR (W/kg)
initial position (10mm min. separation)	0.411
15	0.179
20	0.126
25	0.007

GE0421 Globetrotter Express Card with host Laptop 2 (Sony Vaio VGN-TZ31MN/N) in GPRS850 MS Class 10 at 824.2MHz Channel 128

Distance (mm)	Single point SAR (W/kg)
initial position (10mm min. separation)	0.492
15	0.277
20	0.200
25	0.124



SECTION 2

TEST DETAILS

Specific Absorption Rate Testing of the Option NV
GE0421 Globetrotter Express Card

2.1 SAR MEASUREMENT SYSTEM

2.1.1 ROBOT SYSTEM SPECIFICATION

The SAR measurement system being used is the IndexSAR SARA2 system, which consists of a Mitsubishi RV-E2 6-axis robot arm and controller, IndexSAR probe and amplifier and SAM phantom Head Shape. The robot is used to articulate the probe to programmed positions inside the phantom head to obtain the SAR readings from the DUT.

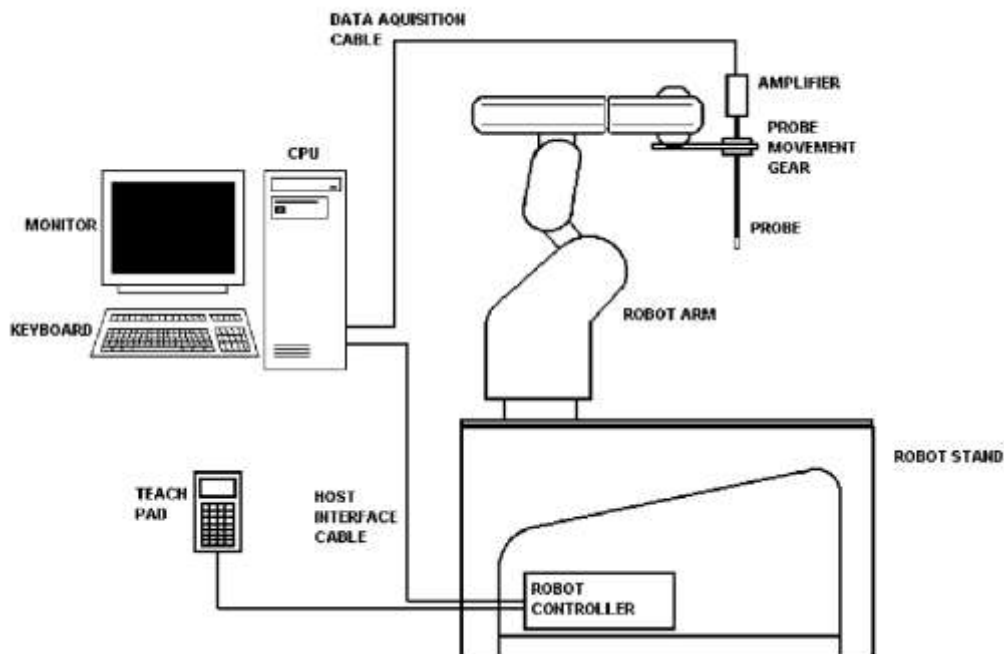

Figure 1: Schematic diagram of the SAR measurement system

The system is controlled remotely from a PC, which contains the software to control the robot and data acquisition equipment. The software also displays the data obtained from test scans.

The position and digitised shape of the phantom heads are made available to the software for accurate positioning of the probe and reduction of set-up time.

The SAM phantom heads are individually digitised using a Mitutoyo CMM machine to a precision of 0.001mm. The data is then converted into a shape format for the software, providing an accurate description of the phantom shell.

In operation, the system first does an area (2D) scan at a fixed depth within the liquid from the inside wall of the phantom. When the maximum SAR point has been found, the system will then carry out a 3D scan centred at that point to determine volume averaged SAR level.



2.1 SAR MEASUREMENT SYSTEM

2.1.2 PROBE AND AMPLIFIER SPECIFICATION

IXP-050 IndexSAR Isotropic Immersible SAR probe

The probes are constructed using three orthogonal dipole sensors arranged on an interlocking, triangular prism core. The probes have built-in shielding against static charges and are contained within a PEEK cylindrical enclosure material at the tip. Probe calibration is described in the following section.

IFA-010 Fast Amplifier

Technical description of IndexSAR IFA-010 Fast probe amplifier
 A block diagram of the fast probe amplifier electronics is shown below.

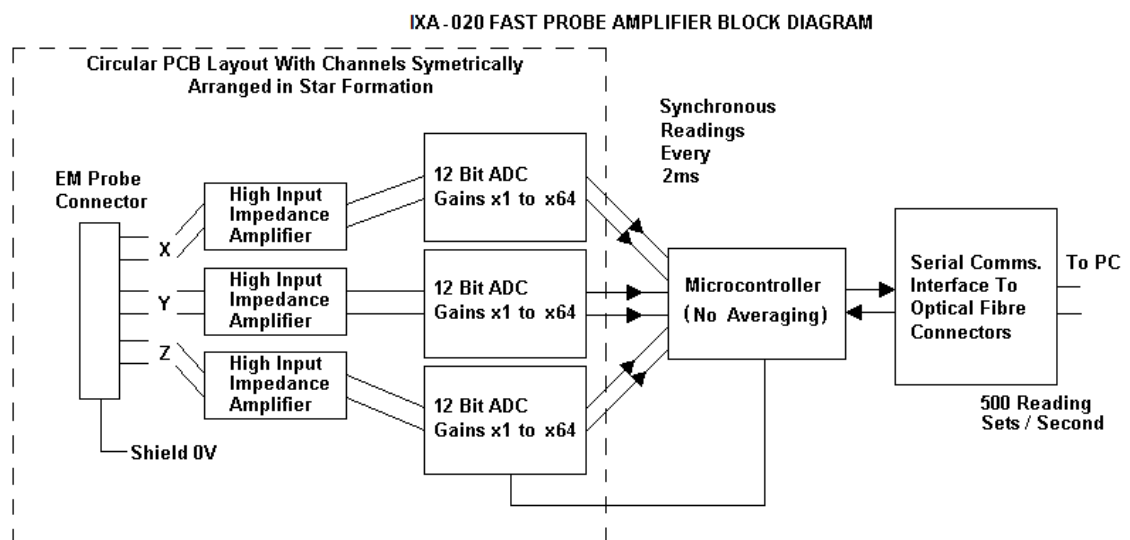

Figure 2: Block diagram of the fast probe amplifier electronic

This amplifier has a time constant of approx. $50\mu s$, which is much faster than the SAR probe response time. The overall system time constant is therefore that of the probe ($<1ms$) and reading sets for all three channels (simultaneously) are returned every 2ms to the PC. The conversion period is approx. $1\mu s$ at the start of each 2ms period. This enables the probe to follow pulse modulated signals of periods $\gg 2ms$. The PC software applies the linearization procedure separately to each reading, so no linearization corrections for the averaging of modulated signals are needed in this case. It is important to ensure that the probe reading frequency and the pulse period are not synchronised and the behaviour with pulses of short duration in comparison with the measurement interval need additional consideration.

Phantoms

The Cube phantom used is a Perspex Box IndexSAR item IXB-070. Dimensions of 200w x 200d x 200h (mm). This phantom is used with IndexSAR side bench IXM-030.

The Flat phantom used is a Rectangular Perspex Box IndexSAR item. Dimensions of 210w x 150d x 200h (mm). This phantom is used with IndexSAR upright bench. The phantom and robot alignment is assured by both mechanical and laser registration systems.

2.1 SAR MEASUREMENT SYSTEM

2.1.3 SAR MEASUREMENT PROCEDURE



Figure 3: Principal components of the SAR measurement test bench

The major components of the test bench are shown in the picture above. A test set and dipole antenna control the handset via an air link and a low-mass phone holder can position the phone at either ear. Graduated scales are provided to set the phone in the 15 degree position. The upright phantom head holds approx. 7 litres of simulant liquid. The phantom is filled and emptied through a 45mm diameter penetration hole in the top of the head.

After an area scan has been done at a fixed distance of 8mm from the surface of the phantom on the source side, a 3D scan is set up around the location of the maximum spot SAR. First, a point within the scan area is visited by the probe and a SAR reading taken at the start of testing. At the end of testing, the probe is returned to the same point and a second reading is taken. Comparison between these start and end readings enables the power drift during measurement to be assessed.

SARA2 Interpolation and Extrapolation schemes

SARA2 software contains support for both 2D cubic B-spline interpolation as well as 3D cubic B-spline interpolation. In addition, for extrapolation purposes, a general n^{th} order polynomial fitting routine is implemented following a singular value decomposition algorithm presented in [4]. A 4th order polynomial fit is used by default for data extrapolation, but a linear-logarithmic fitting function can be selected as an option. The polynomial fitting procedures have been tested by comparing the fitting coefficients generated by the SARA2 procedures with those obtained using the polynomial fit functions of Microsoft Excel when applied to the same test input data.

Interpolation of 2D area scan

The 2D cubic B-spline interpolation is used after the initial area scan at fixed distance from the phantom shell wall. The initial scan data are collected with approx. 115mm spatial resolution and spline interpolation is used to find the location of the local maximum to within a 1mm resolution for positioning the subsequent 3D scanning.

2.1 SAR MEASUREMENT SYSTEM

2.1.3 SAR MEASUREMENT PROCEDURE

Extrapolation of 3D scan

For the 3D scan, data are collected on a spatially regular 3D grid having (by default) 6.4 mm steps in the lateral dimensions and 3.5 mm steps in the depth direction (away from the source). SARA2 enables full control over the selection of alternative step sizes in all directions.

The digitised shape of the head is available to the SARA2 software, which decides which points in the 3D array are sufficiently well within the shell wall to be 'visited' by the SAR probe. After the data collection, the data are extrapolated in the depth direction to assign values to points in the 3D array closer to the shell wall. A notional extrapolation value is also assigned to the first point outside the shell wall so that subsequent interpolation schemes will be applicable right up to the shell wall boundary.

Interpolation of 3D scan and volume averaging

The procedure used for defining the shape of the volumes used for SAR averaging in the SARA2 software follow the method of adapting the surface of the 'cube' to conform with the curved inner surface of the phantom (see Appendix C.2.2.1 in EN 50361:2001). This is called, here, the conformal scheme.

For each row of data in the depth direction, the data are extrapolated and interpolated to less than 1mm spacing and average values are calculated from the phantom surface for the row of data over distances corresponding to the requisite depth for 10g and 1g cubes. This results in two 2D arrays of data, which are then cubic B-spline interpolated to sub mm lateral resolution. A search routine then moves an averaging square around through the 2D array and records the maximum value of the corresponding 1g and 10g volume averages. For the definition of the surface in this procedure, the digitised position of the headshell surface is used for measurement in head-shaped phantoms. For measurements in rectangular, box phantoms, the distance between the phantom wall and the closest set of gridded data points is entered into the software.

For measurements in box-shaped phantoms, this distance is under the control of the user. The effective distance must be greater than 2.5mm as this is the tip-sensor distance and to avoid interface proximity effects, it should be at least 5mm. A value of 6 or 8mm is recommended. This distance is called **dbe** in EN 50361:2001.

For automated measurements inside the head, the distance cannot be less than 2.5mm, which is the radius of the probe tip and to avoid interface proximity effects, a minimum clearance distance of x mm is retained. The actual value of **dbe** will vary from point to point depending upon how the spatially-regular 3D grid points fit within the shell. The greatest separation is when a grid point is just not visited due to the probe tip dimensions. In this case the distance could be as large as the step-size plus the minimum clearance distance (i.e with $x=5$ and a step size of 3.5, **dbe** will be between 3.5 and 8.5mm).

The default step size (**dstep** in EN 50361:2001) used is 3.5mm, but this is under user-control. The compromise is with time of scan, so it is not practical to make it much smaller or scan times become long and power-drop influences become larger.

The robot positioning system specification for the repeatability of the positioning (**dss** in EN50361:2001) is +/- 0.04mm.



2.1 SAR MEASUREMENT SYSTEM

2.1.3 SAR MEASUREMENT PROCEDURE

The phantom shell is made by an industrial moulding process from the CAD files of the SAM shape, with both internal and external moulds. For the upright phantoms, the external shape is subsequently digitised on a Mitutoyo CMM machine (Euro C574) to a precision of 0.001mm. Wall thickness measurements made non-destructively with an ultrasonic sensor indicate that the shell thickness (**dph**) away from the ear is 2.0 +/- 0.1mm. The ultrasonic measurements were calibrated using additional mechanical measurements on available cut surfaces of the phantom shells.

For the upright phantom, the alignment is based upon registration of the rotation axis of the phantom on its 253mm-diameter baseplate bearing and the position of the probe axis when commanded to go to the axial position. A laser alignment tool is provided (procedure detailed elsewhere). This enables the registration of the phantom tip (**dmis**) to be assured to within approx. 0.2mm. This alignment is done with reference to the actual probe tip after installation and probe alignment. The rotational positioning of the phantom is variable – offering advantages for special studies, but locating pins ensure accurate repositioning at the principal positions (LH and RH ears).



2.2 MAXIMUM GPRS 850 SAR TEST RESULT AND COURSE AREA SCAN – 2D

SYSTEM / SOFTWARE:	SARA2 / 2.53 VPM	INPUT POWER DRIFT:	0.0dB
DATE / TIME:	30/06/2008 11:49:36	DUT BATTERY MODEL/NO:	N/A
FILENAME:	75903886-251000-01.txt	PROBE SERIAL NUMBER:	0187
AMBIENT TEMPERATURE:	23.1°C	LIQUID SIMULANT:	835 Body
DEVICE UNDER TEST:	GE0421 in adapter	RELATIVE PERMITTIVITY:	56.84
RELATIVE HUMIDITY:	45.1%	CONDUCTIVITY:	0.994
PHANTOM S/NO:	HeadBox01.csv	LIQUID TEMPERATURE:	22.3°C
PHANTOM ROTATION:	0°	MAX SAR X-AXIS LOCATION:	20.00 mm
DUT POSITION:	Rear Facing 10mm separation	MAX SAR Y-AXIS LOCATION:	0.00 mm
ANTENNA CONFIGURATION:	Internal Fixed	MAX E FIELD:	22.27 V/m
TEST FREQUENCY:	836.4MHz	SAR 1g:	0.598 W/kg
AIR FACTORS:	346 / 439 / 415	SAR 10g:	0.409 W/kg
CONVERSION FACTORS:	0.318 / 0.318 / 0.318	SAR START:	0.158 W/kg
TYPE OF MODULATION:	GMSK (GPRS)	SAR END:	0.158 W/kg
MODN. DUTY CYCLE:	25%	SAR DRIFT DURING SCAN:	-0.46 %
DIODE COMPRESSION FACTORS (V*200):	20 / 20 / 20	PROBE BATTERY LAST CHANGED:	02/07/2008
INPUT POWER LEVEL:	2 x 33dBm	EXTRAPOLATION:	poly4

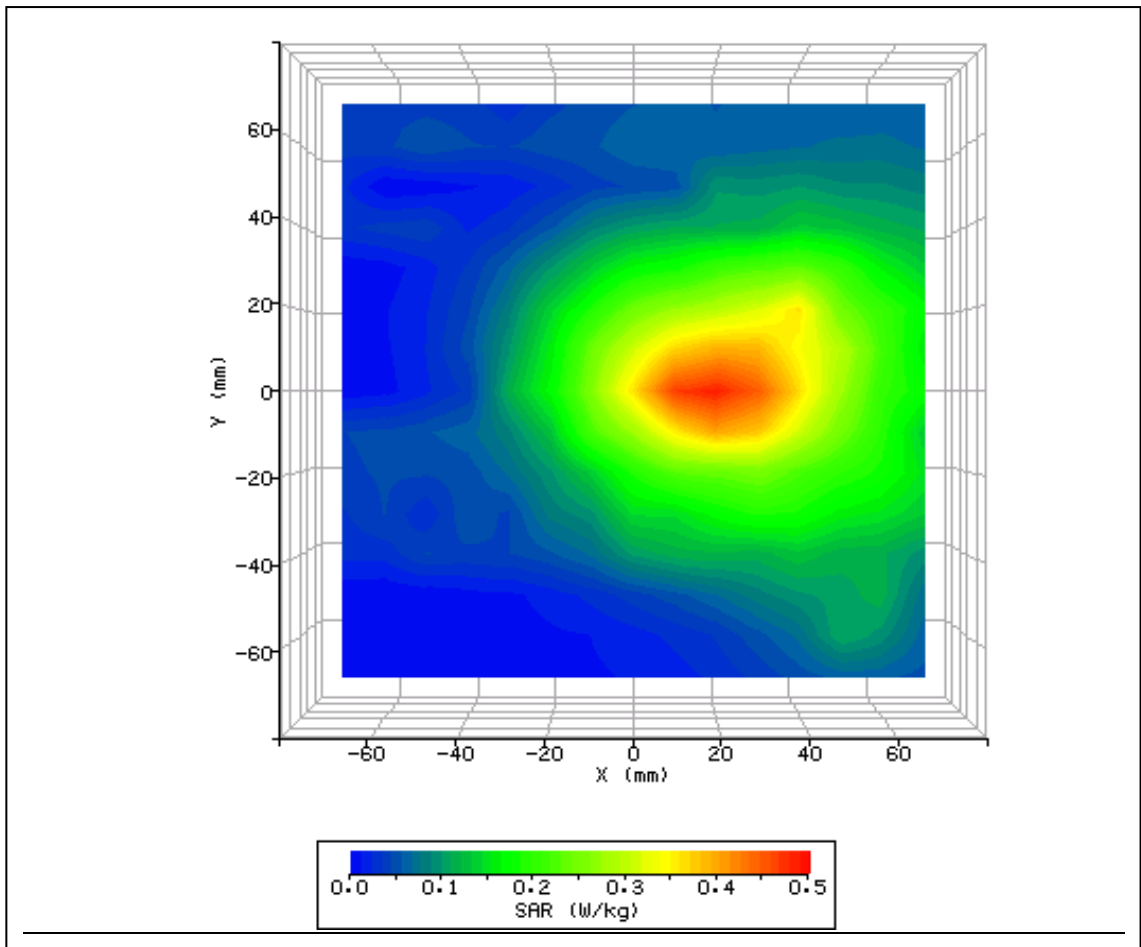

Figure 4: SAR Body Testing Results for the Option GE0421 Express Card with adapter in 10mm separation distance from bottom of flat phantom; Tested at 836.4MHz with Host Laptop HP Compaq nc 6320 in rear facing phantom configuration



2.2 MAXIMUM GPRS 850 SAR TEST RESULT AND COURSE AREA SCAN – 2D

SYSTEM / SOFTWARE:	SARA2 / 2.53 VPM	INPUT POWER DRIFT:	0.0dB
DATE / TIME:	30/06/2008 12:50:20	DUT BATTERY MODEL/NO:	N/A
FILENAME:	75903886-251000-02.txt	PROBE SERIAL NUMBER:	0187
AMBIENT TEMPERATURE:	23.1°C	LIQUID SIMULANT:	835 Body
DEVICE UNDER TEST:	GE0421 in adapter	RELATIVE PERMITTIVITY:	56.84
RELATIVE HUMIDITY:	43.2%	CONDUCTIVITY:	0.994
PHANTOM S/NO:	HeadBox01.csv	LIQUID TEMPERATURE:	22.3°C
PHANTOM ROTATION:	0°	MAX SAR X-AXIS LOCATION:	26.00 mm
DUT POSITION:	Rear Facing 10mm separation	MAX SAR Y-AXIS LOCATION:	1.00 mm
ANTENNA CONFIGURATION:	Internal Fixed	MAX E FIELD:	22.03 V/m
TEST FREQUENCY:	824.2MHz	SAR 1g:	0.540 W/kg
AIR FACTORS:	346 / 439 / 415	SAR 10g:	0.373 W/kg
CONVERSION FACTORS:	0.318 / 0.318 / 0.318	SAR START:	0.144 W/kg
TYPE OF MODULATION:	GMSK (GPRS)	SAR END:	0.154 W/kg
MODN. DUTY CYCLE:	25%	SAR DRIFT DURING SCAN:	6.91 %
DIODE COMPRESSION FACTORS (V*200):	20 / 20 / 20	PROBE BATTERY LAST CHANGED:	02/07/2008
INPUT POWER LEVEL:	2 x 33dBm	EXTRAPOLATION:	poly4

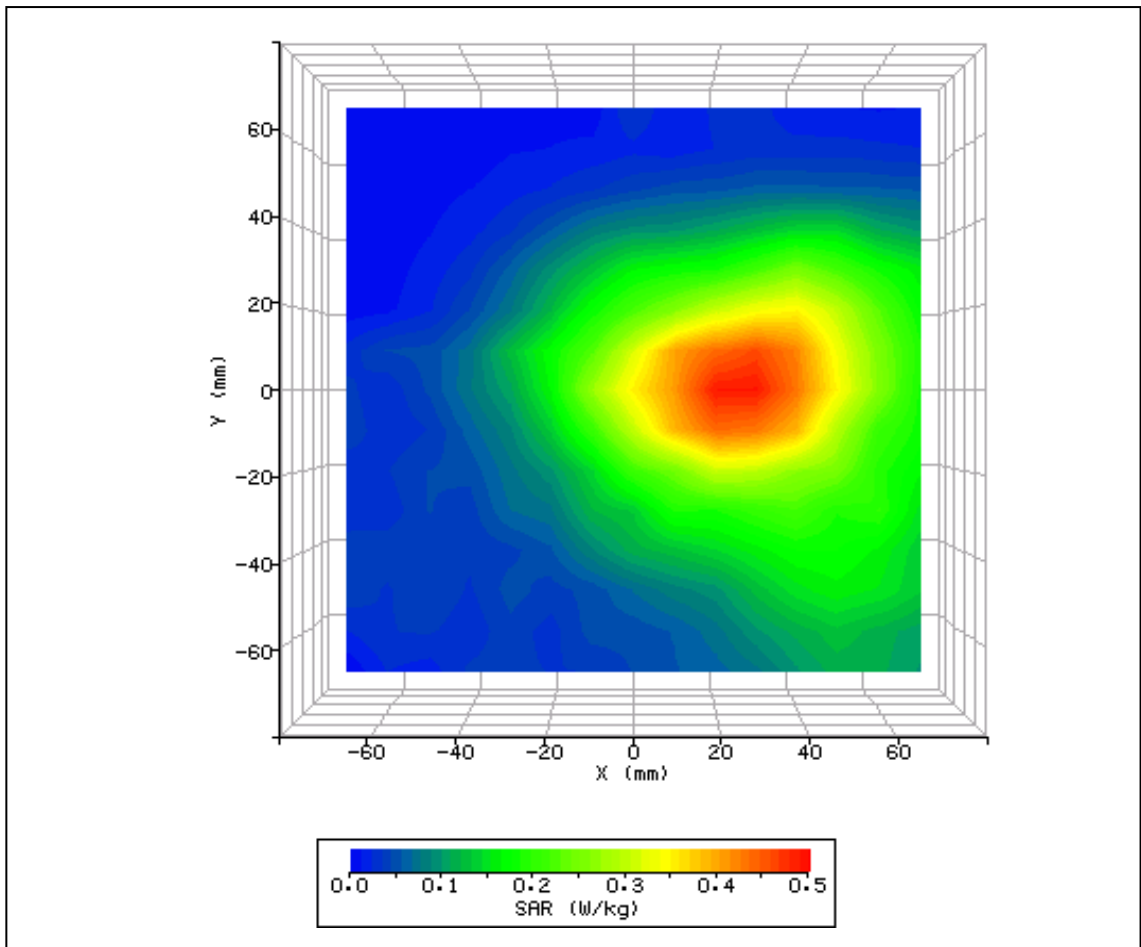

Figure 5: SAR Body Testing Results for the Option GE0421 Express Card with adapter in 10mm separation distance from bottom of flat phantom; Tested at 824.2MHz with Host Laptop HP Compaq nc 6320 in rear facing phantom configuration



2.2 MAXIMUM GPRS 850 SAR TEST RESULT AND COURSE AREA SCAN – 2D

SYSTEM / SOFTWARE:	SARA2 / 2.53 VPM	INPUT POWER DRIFT:	0.0dB
DATE / TIME:	30/06/2008 14:19:01	DUT BATTERY MODEL/NO:	N/A
FILENAME:	75903886-251000-03.txt	PROBE SERIAL NUMBER:	0187
AMBIENT TEMPERATURE:	23.2°C	LIQUID SIMULANT:	835 Body
DEVICE UNDER TEST:	GE0421 in adapter	RELATIVE PERMITTIVITY:	56.84
RELATIVE HUMIDITY:	45.6%	CONDUCTIVITY:	0.994
PHANTOM S/NO:	HeadBox01.csv	LIQUID TEMPERATURE:	22.4°C
PHANTOM ROTATION:	0°	MAX SAR X-AXIS LOCATION:	23.00 mm
DUT POSITION:	Rear Facing 10mm separation	MAX SAR Y-AXIS LOCATION:	0.00 mm
ANTENNA CONFIGURATION:	Internal Fixed	MAX E FIELD:	21.58 V/m
TEST FREQUENCY:	848.8MHz	SAR 1g:	0.518 W/kg
AIR FACTORS:	346 / 439 / 415	SAR 10g:	0.360 W/kg
CONVERSION FACTORS:	0.318 / 0.318 / 0.318	SAR START:	0.161 W/kg
TYPE OF MODULATION:	GMSK (GPRS)	SAR END:	0.159 W/kg
MODN. DUTY CYCLE:	25%	SAR DRIFT DURING SCAN:	-1.54 %
DIODE COMPRESSION FACTORS (V*200):	20 / 20 / 20	PROBE BATTERY LAST CHANGED:	02/07/2008
INPUT POWER LEVEL:	2 x 33dBm	EXTRAPOLATION:	poly4

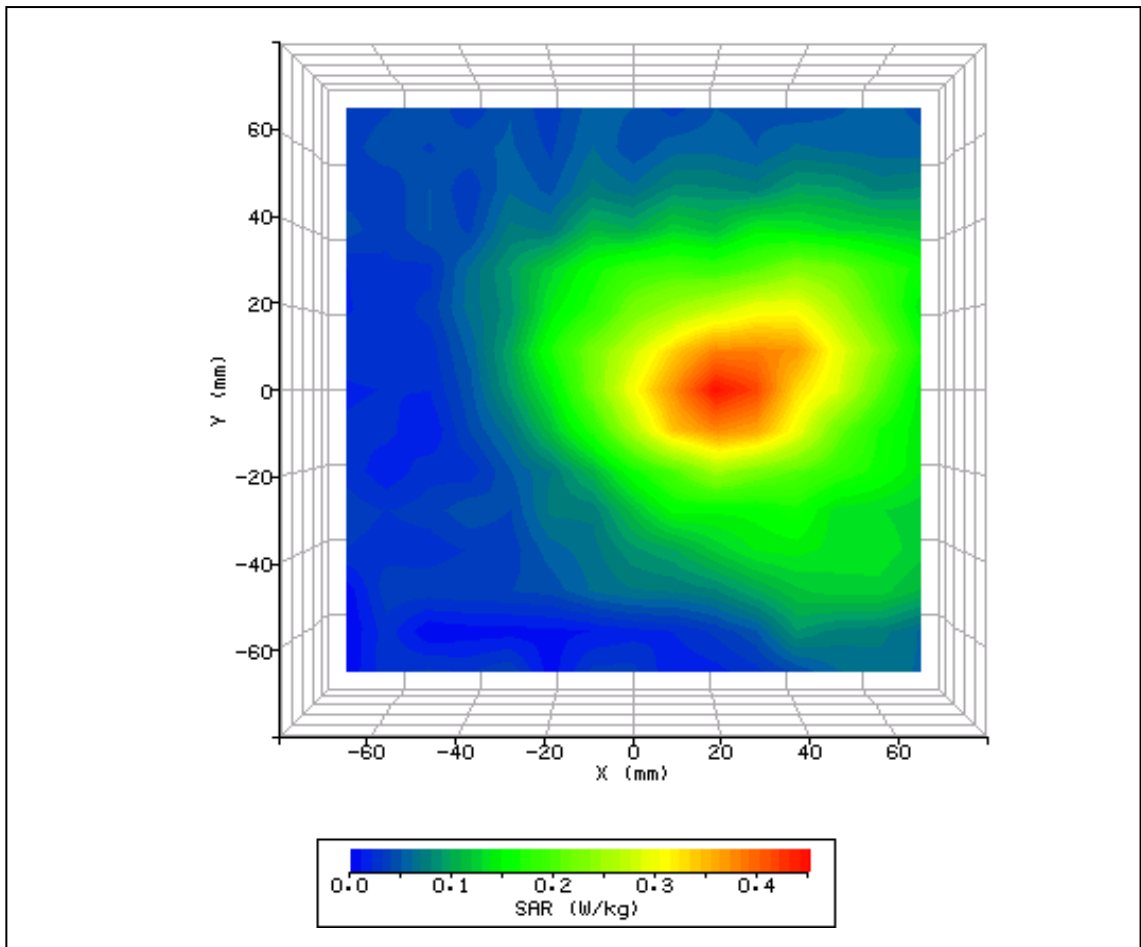

Figure 6: SAR Body Testing Results for the Option GE0421 Express Card with adapter in 10mm separation distance from bottom of flat phantom; Tested at 848.8MHz with Host Laptop HP Compaq nc 6320 in rear facing phantom configuration



2.2 MAXIMUM EGPRS 850 SAR TEST RESULT AND COURSE AREA SCAN – 2D

SYSTEM / SOFTWARE:	SARA2 / 2.53 VPM	INPUT POWER DRIFT:	0.0dB
DATE / TIME:	01/07/2008 08:31:11	DUT BATTERY MODEL/NO:	N/A
FILENAME:	75903886-251000-04.txt	PROBE SERIAL NUMBER:	0187
AMBIENT TEMPERATURE:	23.4°C	LIQUID SIMULANT:	835 Body
DEVICE UNDER TEST:	GE0421 in adapter	RELATIVE PERMITTIVITY:	56.84
RELATIVE HUMIDITY:	30.1%	CONDUCTIVITY:	0.994
PHANTOM S/NO:	HeadBox01.csv	LIQUID TEMPERATURE:	22.3°C
PHANTOM ROTATION:	0°	MAX SAR X-AXIS LOCATION:	17.00 mm
DUT POSITION:	Rear Facing 10mm separation	MAX SAR Y-AXIS LOCATION:	1.00 mm
ANTENNA CONFIGURATION:	Internal Fixed	MAX E FIELD:	14.78 V/m
TEST FREQUENCY:	836.4MHz	SAR 1g:	0.243 W/kg
AIR FACTORS:	346 / 439 / 415	SAR 10g:	0.164 W/kg
CONVERSION FACTORS:	0.318 / 0.318 / 0.318	SAR START:	0.062 W/kg
TYPE OF MODULATION:	GMSK (EGPRS)	SAR END:	0.059 W/kg
MODN. DUTY CYCLE:	25%	SAR DRIFT DURING SCAN:	-5.34 %
DIODE COMPRESSION FACTORS (V*200):	20 / 20 / 20	PROBE BATTERY LAST CHANGED:	02/07/2008
INPUT POWER LEVEL:	2 x 33dBm	EXTRAPOLATION:	poly4

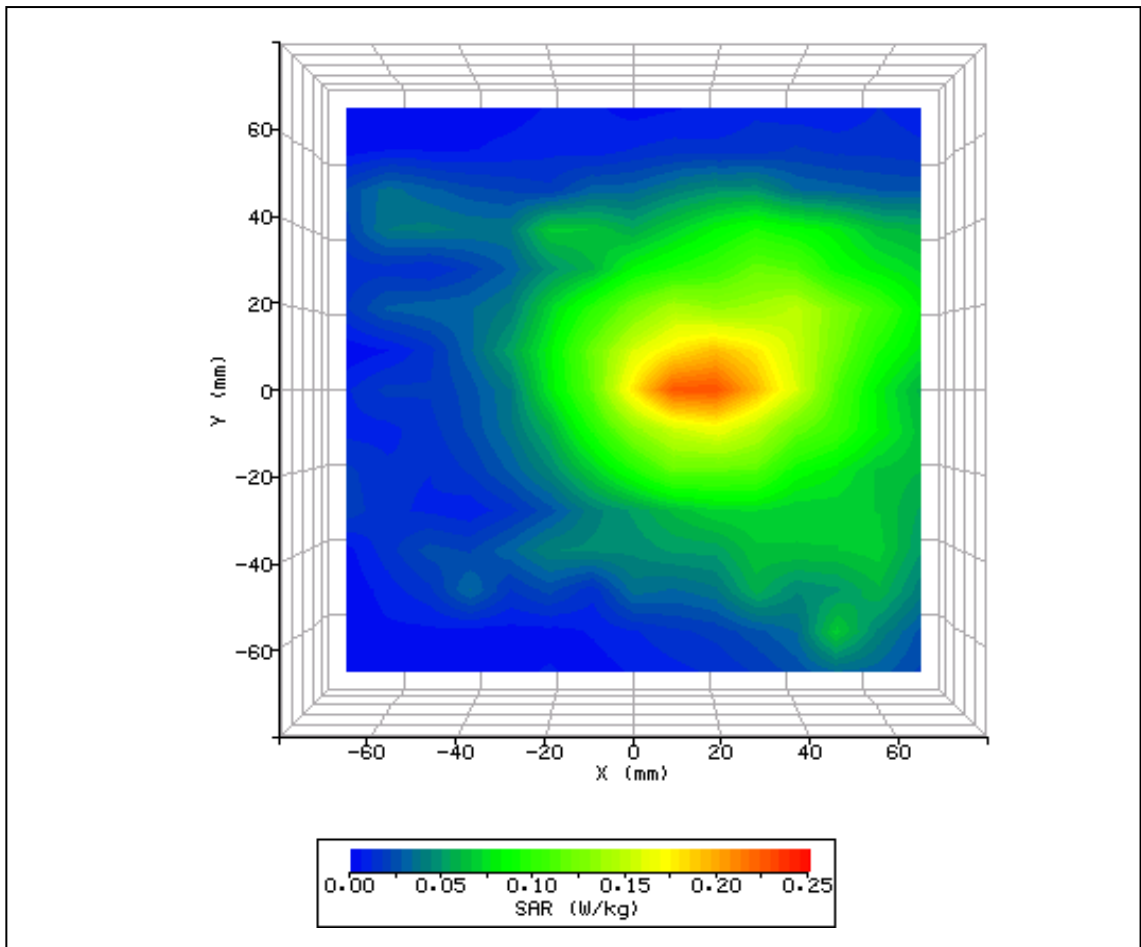

Figure 7: SAR Body Testing Results for the Option GE0421 Express Card with adapter in 10mm separation distance from bottom of flat phantom; Tested at 836.4MHz with Host Laptop HP Compaq nc 6320 in rear facing phantom configuration



2.2 MAXIMUM GPRS 850 SAR TEST RESULT AND COURSE AREA SCAN – 2D

SYSTEM / SOFTWARE:	SARA2 / 2.53 VPM	INPUT POWER DRIFT:	0.0dB
DATE / TIME:	01/07/2008 09:32:40	DUT BATTERY MODEL/NO:	N/A
FILENAME:	75903886-251000-14.txt	PROBE SERIAL NUMBER:	0187
AMBIENT TEMPERATURE:	22.7°C	LIQUID SIMULANT:	835 Body
DEVICE UNDER TEST:	GE0421	RELATIVE PERMITTIVITY:	56.84
RELATIVE HUMIDITY:	37.5%	CONDUCTIVITY:	0.994
PHANTOM S/NO:	HeadBox01.csv	LIQUID TEMPERATURE:	22.3°C
PHANTOM ROTATION:	0°	MAX SAR X-AXIS LOCATION:	9.00 mm
DUT POSITION:	Rear Facing 10mm separation	MAX SAR Y-AXIS LOCATION:	2.00 mm
ANTENNA CONFIGURATION:	Internal Fixed	MAX E FIELD:	25.15 V/m
TEST FREQUENCY:	836.4MHz	SAR 1g:	0.757 W/kg
AIR FACTORS:	346 / 439 / 415	SAR 10g:	0.480 W/kg
CONVERSION FACTORS:	0.318 / 0.318 / 0.318	SAR START:	0.175 W/kg
TYPE OF MODULATION:	GMSK (GPRS)	SAR END:	0.168 W/kg
MODN. DUTY CYCLE:	25%	SAR DRIFT DURING SCAN:	-3.97 %
DIODE COMPRESSION FACTORS (V*200):	20 / 20 / 20	PROBE BATTERY LAST CHANGED:	02/07/2008
INPUT POWER LEVEL:	2 x 33dBm	EXTRAPOLATION:	poly4

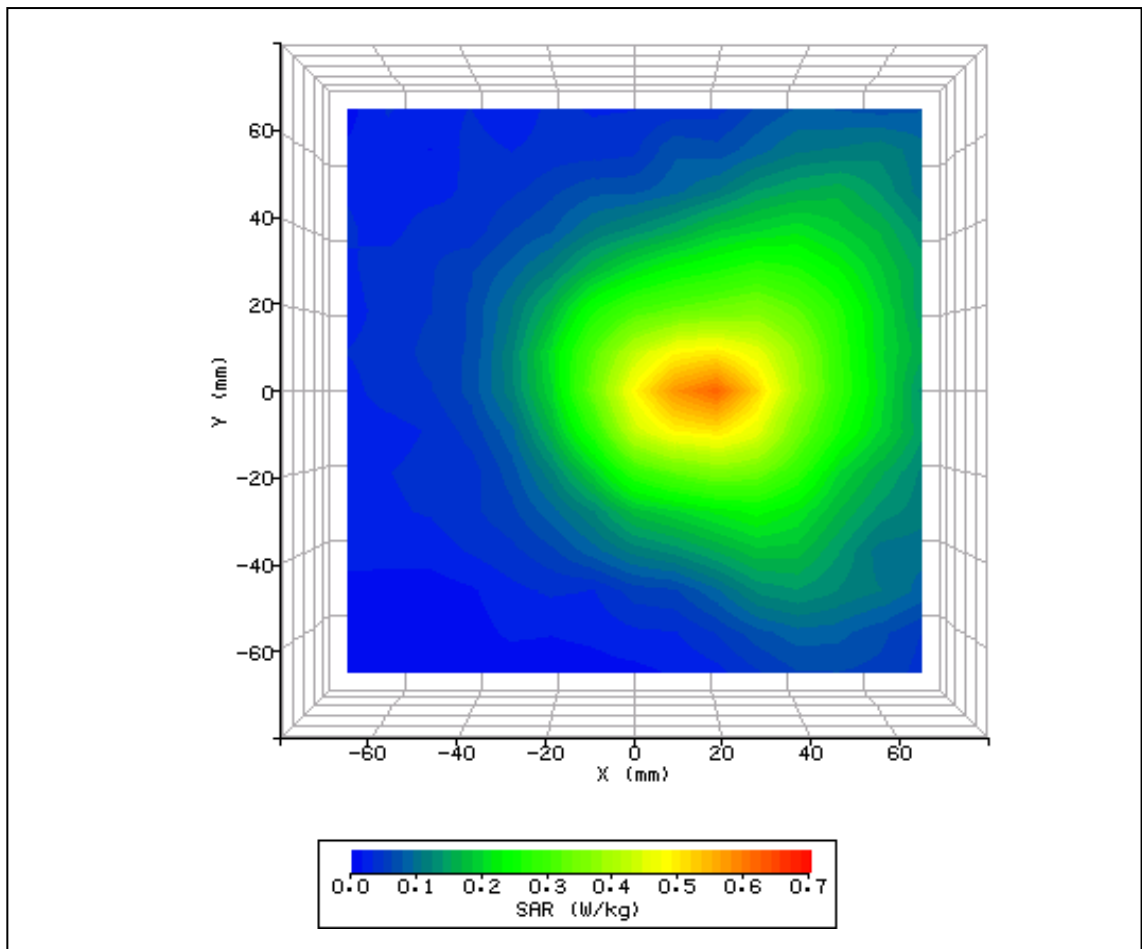

Figure 8: SAR Body Testing Results for the Option GE0421 Express Card in 10mm separation distance from bottom of flat phantom; Tested at 836.4MHz with Host Laptop Sony Vaio VGN-TZ31MN/N in rear facing phantom configuration



2.2 MAXIMUM GPRS 850 SAR TEST RESULT AND COURSE AREA SCAN – 2D

SYSTEM / SOFTWARE:	SARA2 / 2.53 VPM	INPUT POWER DRIFT:	0.0dB
DATE / TIME:	01/07/2008 11:54:04	DUT BATTERY MODEL/NO:	N/A
FILENAME:	75903886-251000-15.txt	PROBE SERIAL NUMBER:	0187
AMBIENT TEMPERATURE:	22.3°C	LIQUID SIMULANT:	835 Body
DEVICE UNDER TEST:	GE0421	RELATIVE PERMITTIVITY:	56.84
RELATIVE HUMIDITY:	35.6%	CONDUCTIVITY:	0.994
PHANTOM S/NO:	HeadBox01.csv	LIQUID TEMPERATURE:	22.3°C
PHANTOM ROTATION:	0°	MAX SAR X-AXIS LOCATION:	5.00 mm
DUT POSITION:	Rear Facing 10mm separation	MAX SAR Y-AXIS LOCATION:	4.00 mm
ANTENNA CONFIGURATION:	Internal Fixed	MAX E FIELD:	25.68 V/m
TEST FREQUENCY:	824.2MHz	SAR 1g:	0.794 W/kg
AIR FACTORS:	346 / 439 / 415	SAR 10g:	0.533 W/kg
CONVERSION FACTORS:	0.318 / 0.318 / 0.318	SAR START:	0.198 W/kg
TYPE OF MODULATION:	GMSK (GPRS)	SAR END:	0.198 W/kg
MODN. DUTY CYCLE:	25%	SAR DRIFT DURING SCAN:	0.04 %
DIODE COMPRESSION FACTORS (V*200):	20 / 20 / 20	PROBE BATTERY LAST CHANGED:	02/07/2008
INPUT POWER LEVEL:	2 x 33dBm	EXTRAPOLATION:	poly4

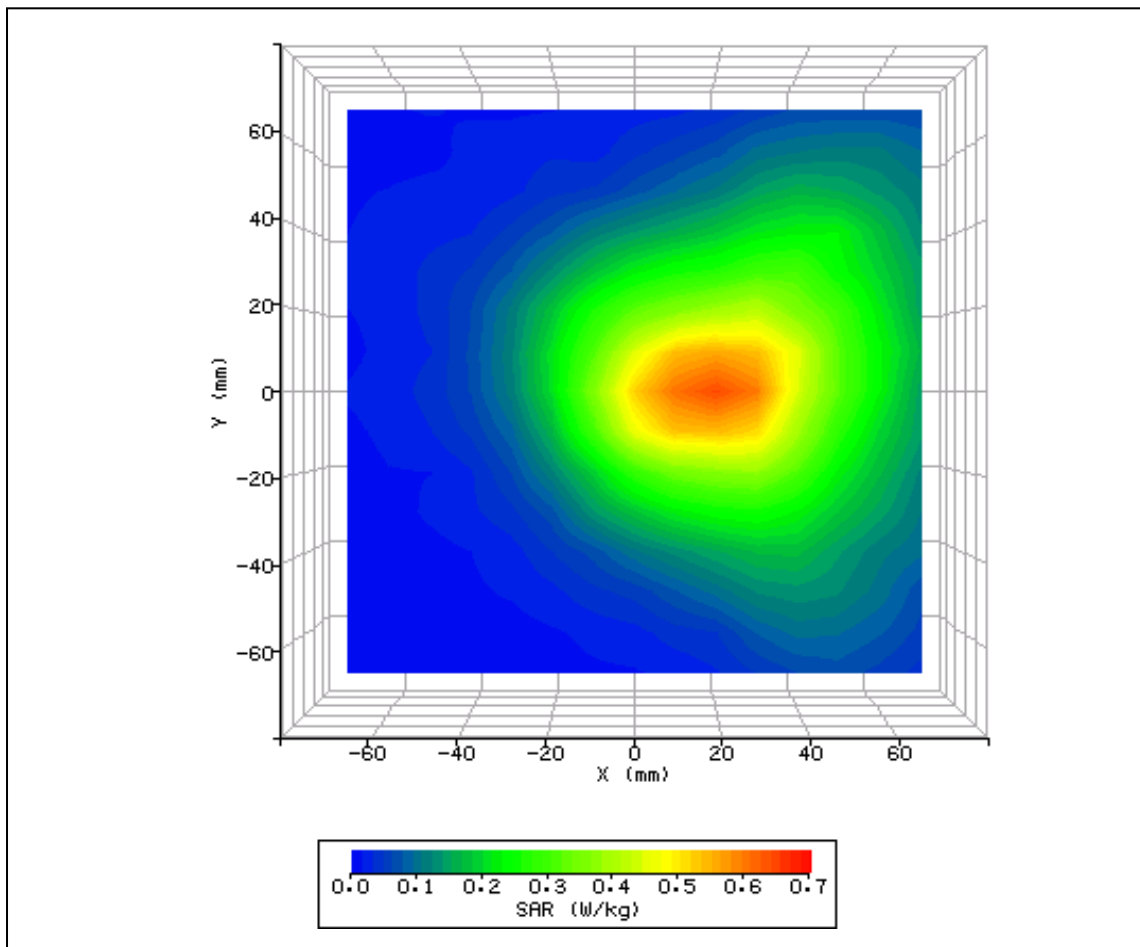

Figure 9: SAR Body Testing Results for the Option GE0421 Express Card in 10mm separation distance from bottom of flat phantom; Tested at 824.2MHz with Host Laptop Sony Vaio VGN-TZ31MN/N in rear facing phantom configuration



2.2 MAXIMUM GPRS 850 SAR TEST RESULT AND COURSE AREA SCAN – 2D

SYSTEM / SOFTWARE:	SARA2 / 2.53 VPM	INPUT POWER DRIFT:	0.0dB
DATE / TIME:	01/07/2008 11:28:49	DUT BATTERY MODEL/NO:	N/A
FILENAME:	75903886-251000-16.txt	PROBE SERIAL NUMBER:	0187
AMBIENT TEMPERATURE:	22.1°C	LIQUID SIMULANT:	835 Body
DEVICE UNDER TEST:	GE0421	RELATIVE PERMITTIVITY:	56.84
RELATIVE HUMIDITY:	32.1%	CONDUCTIVITY:	0.994
PHANTOM S/NO:	HeadBox01.csv	LIQUID TEMPERATURE:	22.2°C
PHANTOM ROTATION:	0°	MAX SAR X-AXIS LOCATION:	6.00 mm
DUT POSITION:	Rear Facing 10mm separation	MAX SAR Y-AXIS LOCATION:	2.00 mm
ANTENNA CONFIGURATION:	Internal Fixed	MAX E FIELD:	23.96 V/m
TEST FREQUENCY:	848.8MHz	SAR 1g:	0.672 W/kg
AIR FACTORS:	346 / 439 / 415	SAR 10g:	0.441 W/kg
CONVERSION FACTORS:	0.318 / 0.318 / 0.318	SAR START:	0.157 W/kg
TYPE OF MODULATION:	GMSK (GPRS)	SAR END:	0.158 W/kg
MODN. DUTY CYCLE:	25%	SAR DRIFT DURING SCAN:	0.88 %
DIODE COMPRESSION FACTORS (V*200):	20 / 20 / 20	PROBE BATTERY LAST CHANGED:	02/07/2008
INPUT POWER LEVEL:	2 x 33dBm	EXTRAPOLATION:	poly4

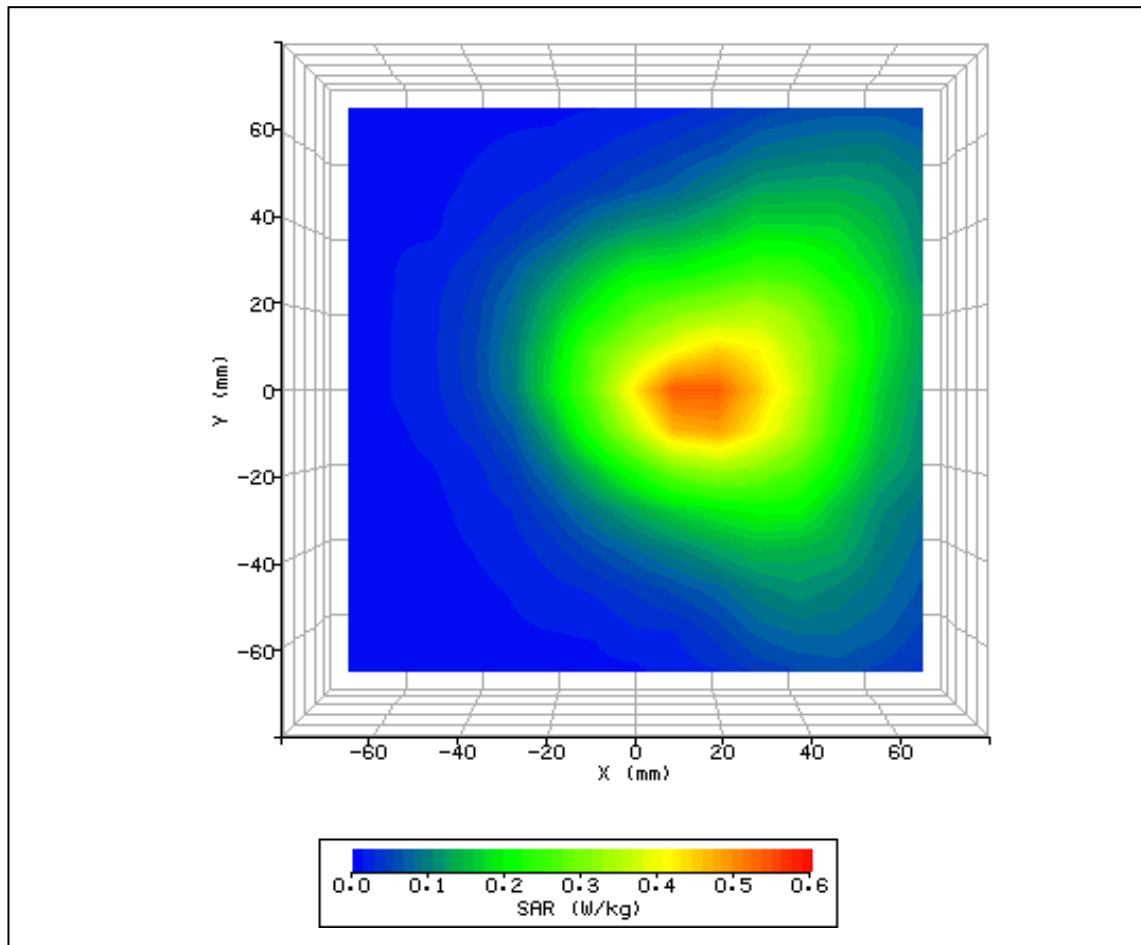

Figure 10: SAR Body Testing Results for the Option GE0421 Express Card in 10mm separation distance from bottom of flat phantom; Tested at 848.8MHz with Host Laptop Sony Vaio VGN-TZ31MN/N in rear facing phantom configuration



2.2 MAXIMUM EGPRS 850 SAR TEST RESULT AND COURSE AREA SCAN – 2D

SYSTEM / SOFTWARE:	SARA2 / 2.53 VPM	INPUT POWER DRIFT:	0.0dB
DATE / TIME:	01/07/2008 12:31:40	DUT BATTERY MODEL/NO:	N/A
FILENAME:	75903886-251000-17.txt	PROBE SERIAL NUMBER:	0187
AMBIENT TEMPERATURE:	22.2°C	LIQUID SIMULANT:	835 Body
DEVICE UNDER TEST:	GE0421	RELATIVE PERMITTIVITY:	56.84
RELATIVE HUMIDITY:	36.5%	CONDUCTIVITY:	0.994
PHANTOM S/NO:	HeadBox01.csv	LIQUID TEMPERATURE:	22.2°C
PHANTOM ROTATION:	0°	MAX SAR X-AXIS LOCATION:	28.00 mm
DUT POSITION:	Rear Facing 10mm separation	MAX SAR Y-AXIS LOCATION:	3.00 mm
ANTENNA CONFIGURATION:	Internal Fixed	MAX E FIELD:	17.05 V/m
TEST FREQUENCY:	824.2MHz	SAR 1g:	0.338 W/kg
AIR FACTORS:	346 / 439 / 415	SAR 10g:	0.223 W/kg
CONVERSION FACTORS:	0.318 / 0.318 / 0.318	SAR START:	0.079 W/kg
TYPE OF MODULATION:	GMSK (EGPRS)	SAR END:	0.082 W/kg
MODN. DUTY CYCLE:	25%	SAR DRIFT DURING SCAN:	3.41 %
DIODE COMPRESSION FACTORS (V*200):	20 / 20 / 20	PROBE BATTERY LAST CHANGED:	02/07/2008
INPUT POWER LEVEL:	2 x 33dBm	EXTRAPOLATION:	poly4

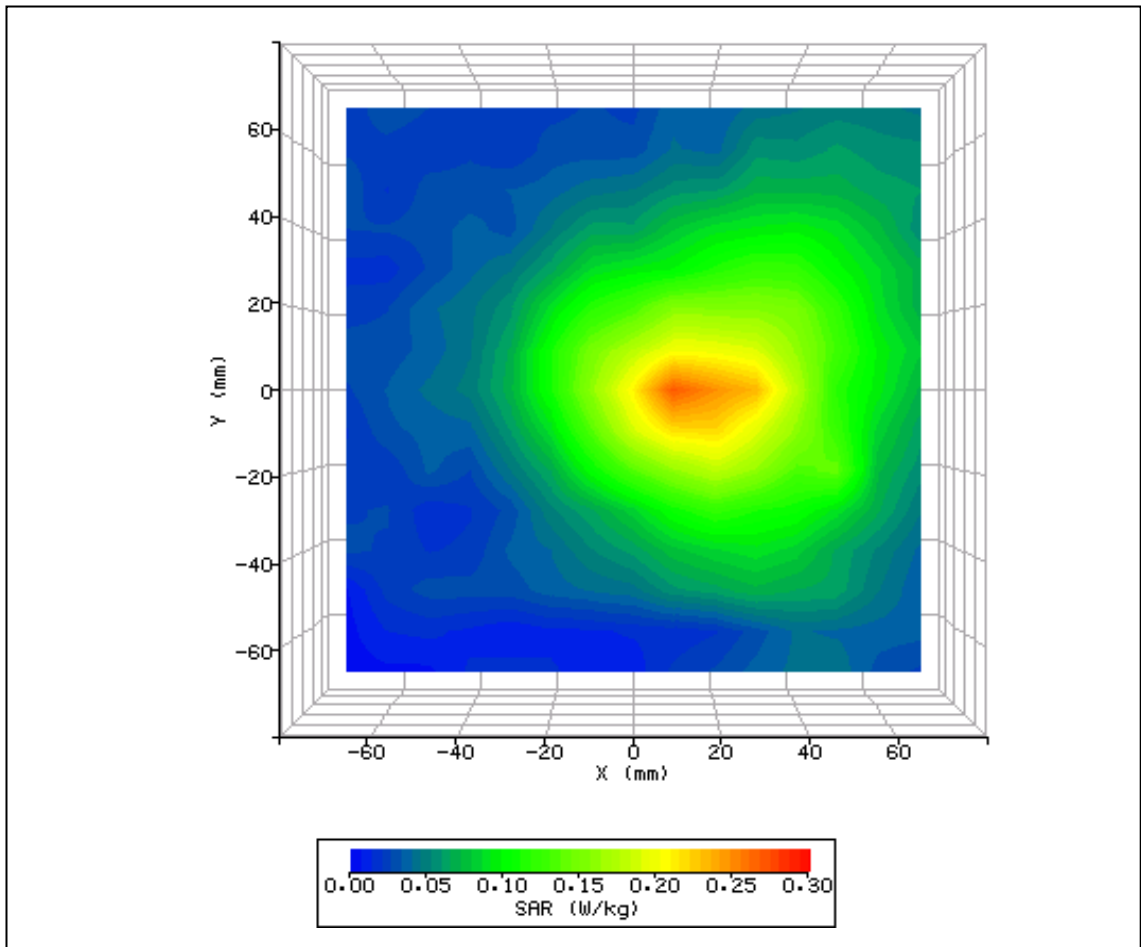

Figure 11: SAR Body Testing Results for the Option GE0421 Express Card in 10mm separation distance from bottom of flat phantom; Tested at 824.2MHz with Host Laptop Sony Vaio VGN-TZ31MN/N in rear facing phantom configuration



2.2 MAXIMUM GPRS 1900 SAR TEST RESULT AND COURSE AREA SCAN – 2D

SYSTEM / SOFTWARE:	SARA2 / 2.53 VPM	INPUT POWER DRIFT:	0.0dB
DATE / TIME:	02/07/2008 19:11:22	DUT BATTERY MODEL/NO:	N/A
FILENAME:	75903886-251000-5.txt	PROBE SERIAL NUMBER:	0187
AMBIENT TEMPERATURE:	23.3°C	LIQUID SIMULANT:	1900 Body
DEVICE UNDER TEST:	GE0421 in adapter	RELATIVE PERMITTIVITY:	54.09
RELATIVE HUMIDITY:	38.9%	CONDUCTIVITY:	1.562
PHANTOM S/NO:	HeadBox01.csv	LIQUID TEMPERATURE:	21.7°C
PHANTOM ROTATION:	0°	MAX SAR X-AXIS LOCATION:	18.00 mm
DUT POSITION:	Rear Facing 10mm separation	MAX SAR Y-AXIS LOCATION:	0.00 mm
ANTENNA CONFIGURATION:	Internal Fixed	MAX E FIELD:	19.02 V/m
TEST FREQUENCY:	1880.0MHz	SAR 1g:	0.660 W/kg
AIR FACTORS:	346 / 439 / 415	SAR 10g:	0.352 W/kg
CONVERSION FACTORS:	0.440 / 0.440 / 0.440	SAR START:	0.087 W/kg
TYPE OF MODULATION:	GMSK (GPRS)	SAR END:	0.085 W/kg
MODN. DUTY CYCLE:	50%	SAR DRIFT DURING SCAN:	-3.10 %
DIODE COMPRESSION FACTORS (V*200):	20 / 20 / 20	PROBE BATTERY LAST CHANGED:	02/07/2008
INPUT POWER LEVEL:	4 x 30dBm	EXTRAPOLATION:	poly4

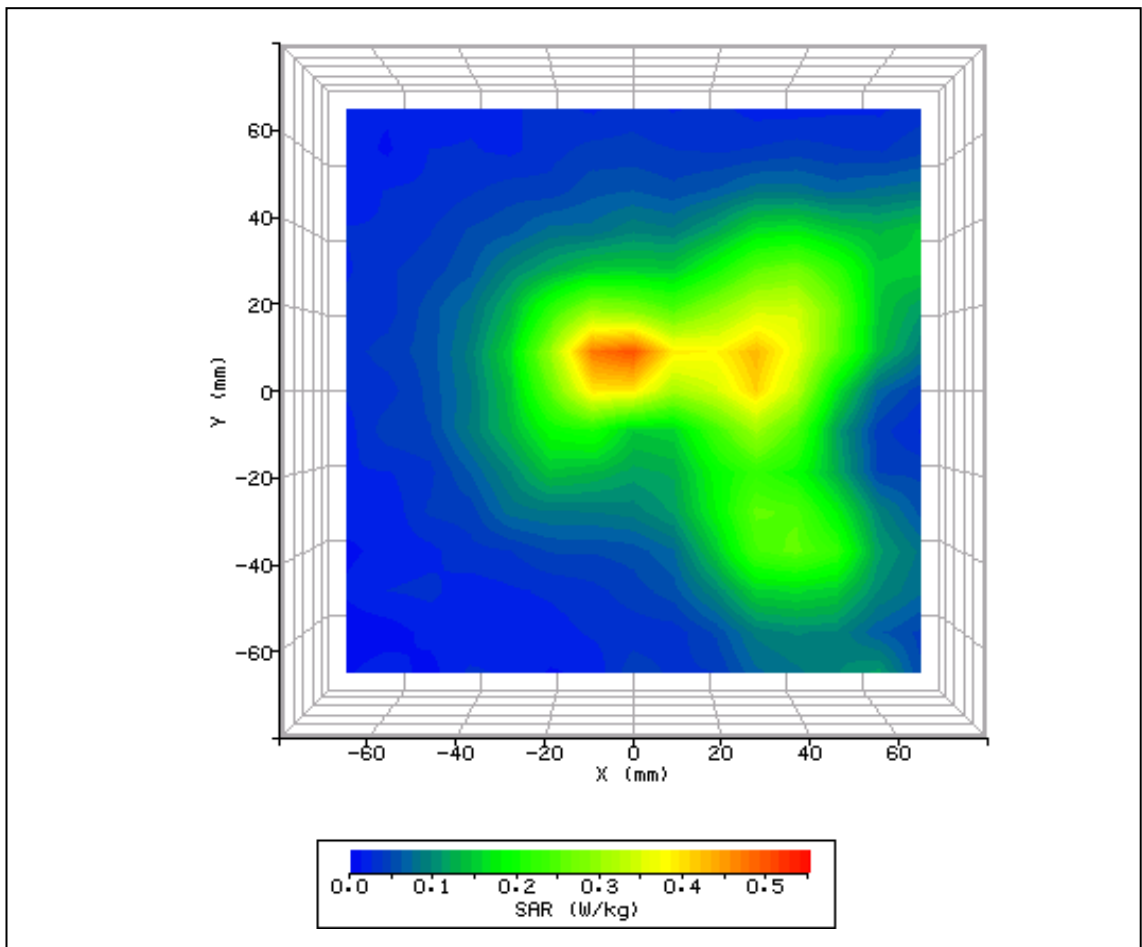

Figure 12: SAR Body Testing Results for the Option GE0421 Express Card with adapter in 10mm separation distance from bottom of flat phantom; Tested at 1880.0MHz with Host Laptop HP Compaq nc 6320 in rear facing phantom configuration



2.2 MAXIMUM GPRS 1900 SAR TEST RESULT AND COURSE AREA SCAN – 2D

SYSTEM / SOFTWARE:	SARA2 / 2.53 VPM	INPUT POWER DRIFT:	0.0dB
DATE / TIME:	02/07/2008 19:38:51	DUT BATTERY MODEL/NO:	N/A
FILENAME:	75903886-251000-6.txt	PROBE SERIAL NUMBER:	0187
AMBIENT TEMPERATURE:	23.1°C	LIQUID SIMULANT:	1900 Body
DEVICE UNDER TEST:	GE0421 in adapter	RELATIVE PERMITTIVITY:	54.09
RELATIVE HUMIDITY:	35.8%	CONDUCTIVITY:	1.562
PHANTOM S/NO:	HeadBox01.csv	LIQUID TEMPERATURE:	21.7°C
PHANTOM ROTATION:	0°	MAX SAR X-AXIS LOCATION:	19.00 mm
DUT POSITION:	Rear Facing 10mm separation	MAX SAR Y-AXIS LOCATION:	0.00 mm
ANTENNA CONFIGURATION:	Internal Fixed	MAX E FIELD:	16.66 V/m
TEST FREQUENCY:	1850.2MHz	SAR 1g:	0.539 W/kg
AIR FACTORS:	346 / 439 / 415	SAR 10g:	0.326 W/kg
CONVERSION FACTORS:	0.440 / 0.440 / 0.440	SAR START:	0.092 W/kg
TYPE OF MODULATION:	GMSK (GPRS)	SAR END:	0.093 W/kg
MODN. DUTY CYCLE:	50%	SAR DRIFT DURING SCAN:	1.49 %
DIODE COMPRESSION FACTORS (V*200):	20 / 20 / 20	PROBE BATTERY LAST CHANGED:	02/07/2008
INPUT POWER LEVEL:	4 x 30dBm	EXTRAPOLATION:	poly4

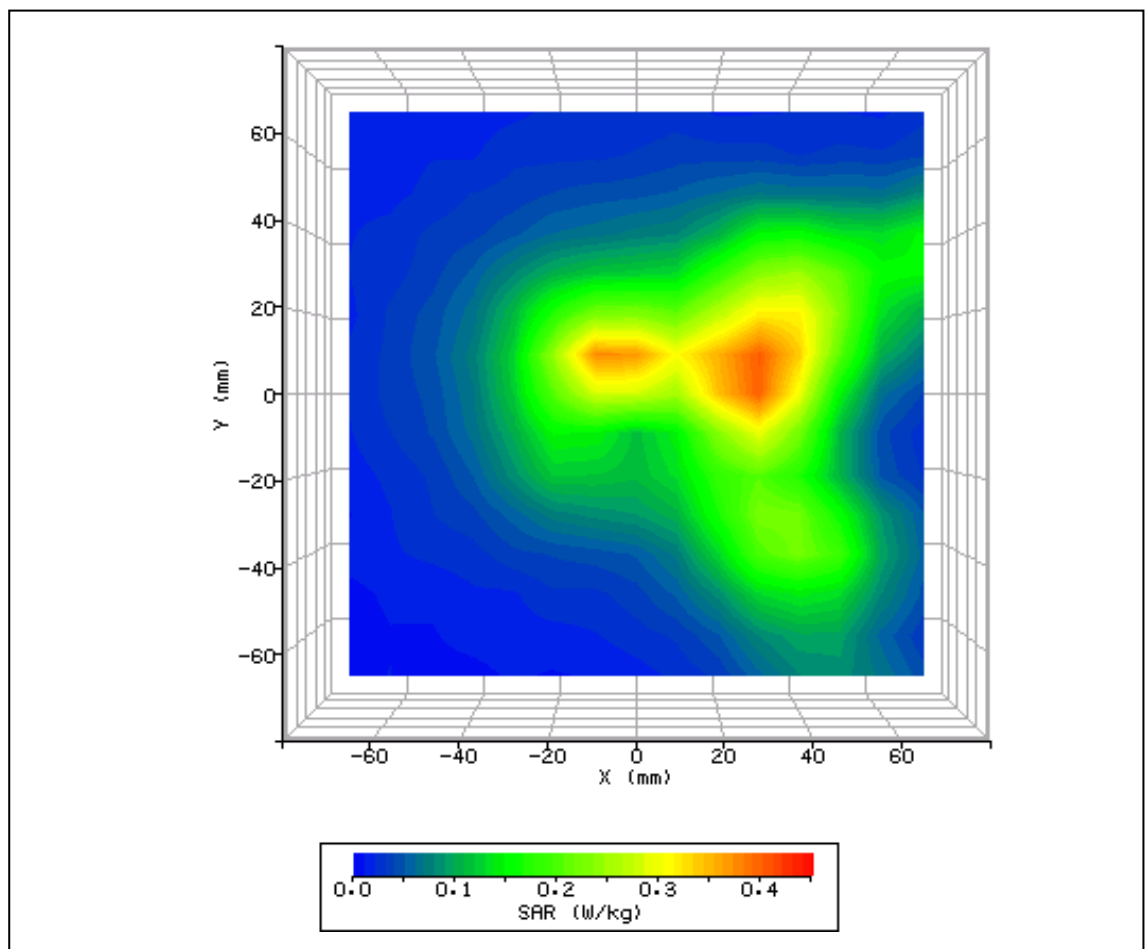

Figure 13: SAR Body Testing Results for the Option GE0421 Express Card with adapter in 10mm separation distance from bottom of flat phantom; Tested at 1850.2MHz with Host Laptop HP Compaq nc 6320 in rear facing phantom configuration



2.2 MAXIMUM GPRS 1900 SAR TEST RESULT AND COURSE AREA SCAN – 2D

SYSTEM / SOFTWARE:	SARA2 / 2.53 VPM	INPUT POWER DRIFT:	0.0dB
DATE / TIME:	02/07/2008 20:12:59	DUT BATTERY MODEL/NO:	N/A
FILENAME:	75903886-251000-7.txt	PROBE SERIAL NUMBER:	0187
AMBIENT TEMPERATURE:	22.7°C	LIQUID SIMULANT:	1900 Body
DEVICE UNDER TEST:	GE0421 in adapter	RELATIVE PERMITTIVITY:	54.09
RELATIVE HUMIDITY:	36.5%	CONDUCTIVITY:	1.562
PHANTOM S/NO:	HeadBox01.csv	LIQUID TEMPERATURE:	21.7°C
PHANTOM ROTATION:	0°	MAX SAR X-AXIS LOCATION:	16.00 mm
DUT POSITION:	Rear Facing 10mm separation	MAX SAR Y-AXIS LOCATION:	-2.00 mm
ANTENNA CONFIGURATION:	Internal Fixed	MAX E FIELD:	18.87 V/m
TEST FREQUENCY:	1909.8MHz	SAR 1g:	0.662 W/kg
AIR FACTORS:	346 / 439 / 415	SAR 10g:	0.359 W/kg
CONVERSION FACTORS:	0.440 / 0.440 / 0.440	SAR START:	0.092 W/kg
TYPE OF MODULATION:	GMSK (GPRS)	SAR END:	0.091 W/kg
MODN. DUTY CYCLE:	50%	SAR DRIFT DURING SCAN:	-1.40 %
DIODE COMPRESSION FACTORS (V*200):	20 / 20 / 20	PROBE BATTERY LAST CHANGED:	02/07/2008
INPUT POWER LEVEL:	4 x 30dBm	EXTRAPOLATION:	poly4

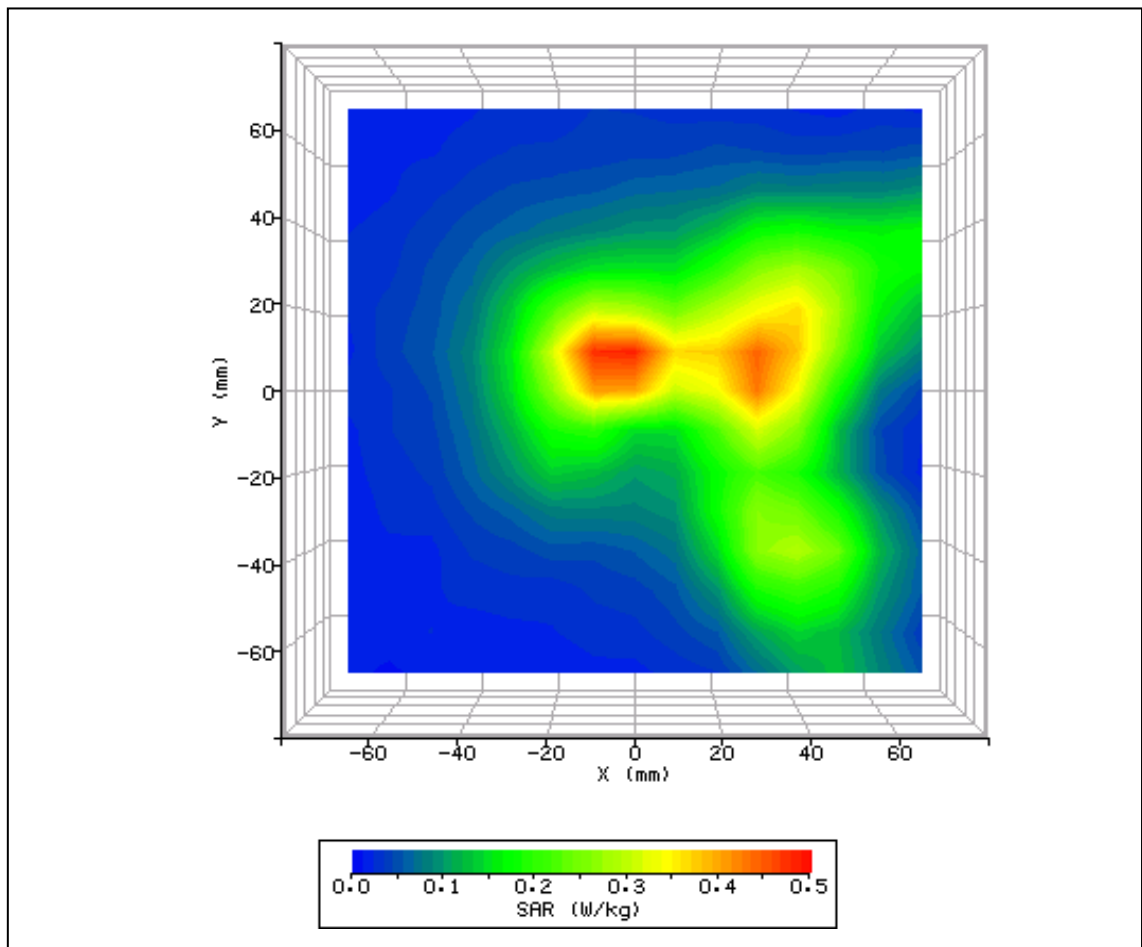

Figure 14: SAR Body Testing Results for the Option GE0421 Express Card with adapter in 10mm separation distance from bottom of flat phantom; Tested at 1909.8MHz with Host Laptop HP Compaq nc 6320 in rear facing phantom configuration



2.2 MAXIMUM EGPRS 1900 SAR TEST RESULT AND COURSE AREA SCAN – 2D

SYSTEM / SOFTWARE:	SARA2 / 2.53 VPM	INPUT POWER DRIFT:	0.0dB
DATE / TIME:	02/07/2008 21:12:47	DUT BATTERY MODEL/NO:	N/A
FILENAME:	75903886-251000-8.txt	PROBE SERIAL NUMBER:	0187
AMBIENT TEMPERATURE:	23.4°C	LIQUID SIMULANT:	1900 Body
DEVICE UNDER TEST:	GE0421 in adapter	RELATIVE PERMITTIVITY:	54.09
RELATIVE HUMIDITY:	42.4%	CONDUCTIVITY:	1.562
PHANTOM S/NO:	HeadBox01.csv	LIQUID TEMPERATURE:	21.7°C
PHANTOM ROTATION:	0°	MAX SAR X-AXIS LOCATION:	14.00 mm
DUT POSITION:	Rear Facing 10mm separation	MAX SAR Y-AXIS LOCATION:	-1.00 mm
ANTENNA CONFIGURATION:	Internal Fixed	MAX E FIELD:	14.85 V/m
TEST FREQUENCY:	1909.8MHz	SAR 1g:	0.408 W/kg
AIR FACTORS:	346 / 439 / 415	SAR 10g:	0.222 W/kg
CONVERSION FACTORS:	0.440 / 0.440 / 0.440	SAR START:	0.057 W/kg
TYPE OF MODULATION:	GMSK (EGPRS)	SAR END:	0.057 W/kg
MODN. DUTY CYCLE:	50%	SAR DRIFT DURING SCAN:	-0.19 %
DIODE COMPRESSION FACTORS (V*200):	20 / 20 / 20	PROBE BATTERY LAST CHANGED:	02/07/2008
INPUT POWER LEVEL:	4 x 30dBm	EXTRAPOLATION:	poly4

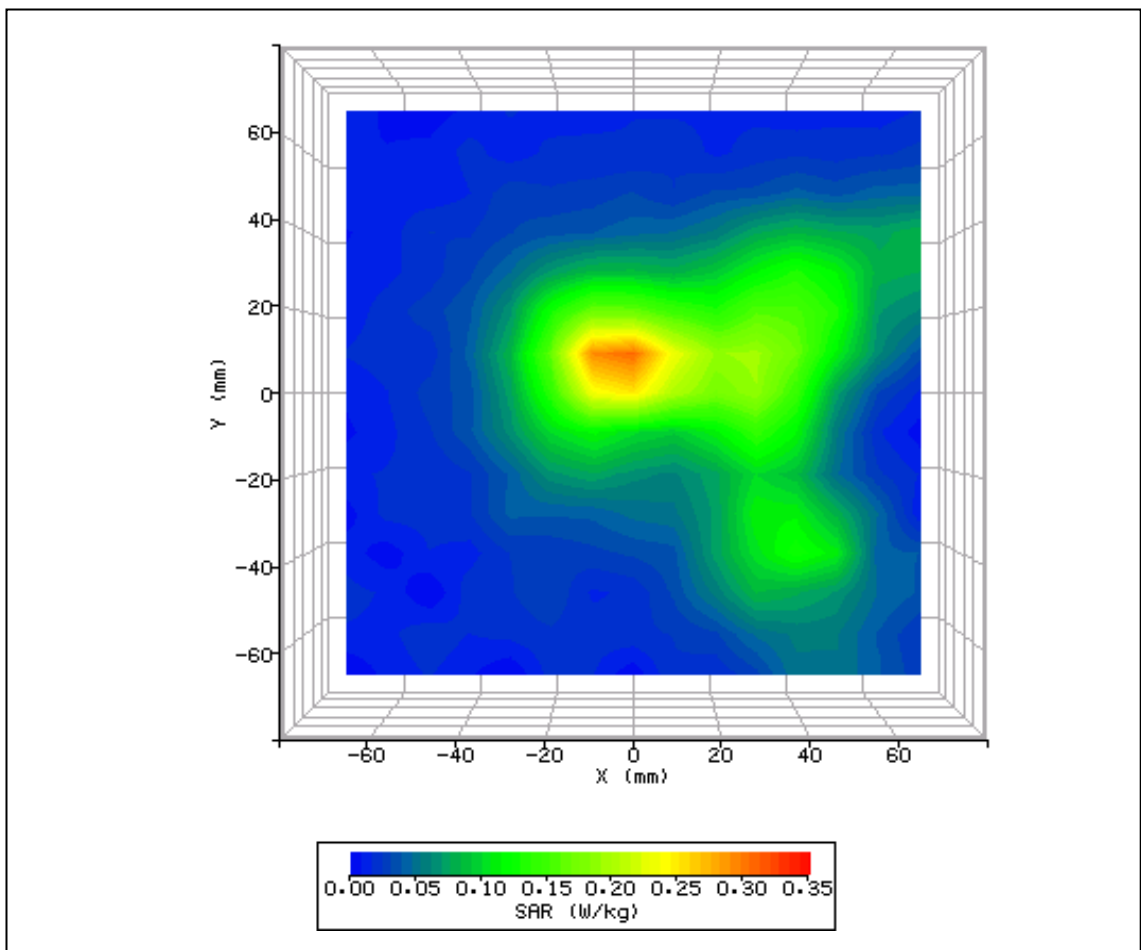

Figure 15: SAR Body Testing Results for the Option GE0421 Express Card with adapter in 10mm separation distance from bottom of flat phantom; Tested at 1909.8MHz with Host Laptop HP Compaq nc 6320 in rear facing phantom configuration



2.2 MAXIMUM GPRS 1900 SAR TEST RESULT AND COURSE AREA SCAN – 2D

SYSTEM / SOFTWARE:	SARA2 / 2.53 VPM	INPUT POWER DRIFT:	0.0dB
DATE / TIME:	02/07/2008 23:03:27	DUT BATTERY MODEL/NO:	N/A
FILENAME:	75903886-251000-18.txt	PROBE SERIAL NUMBER:	0187
AMBIENT TEMPERATURE:	23.2°C	LIQUID SIMULANT:	1900 Body
DEVICE UNDER TEST:	GE0421	RELATIVE PERMITTIVITY:	54.09
RELATIVE HUMIDITY:	41.2%	CONDUCTIVITY:	1.562
PHANTOM S/NO:	HeadBox01.csv	LIQUID TEMPERATURE:	21.8°C
PHANTOM ROTATION:	0°	MAX SAR X-AXIS LOCATION:	29.00 mm
DUT POSITION:	Rear Facing 10mm separation	MAX SAR Y-AXIS LOCATION:	2.00 mm
ANTENNA CONFIGURATION:	Internal Fixed	MAX E FIELD:	17.12 V/m
TEST FREQUENCY:	1880.0MHz	SAR 1g:	0.562 W/kg
AIR FACTORS:	346 / 439 / 415	SAR 10g:	0.332 W/kg
CONVERSION FACTORS:	0.440 / 0.440 / 0.440	SAR START:	0.078 W/kg
TYPE OF MODULATION:	GMSK (GPRS)	SAR END:	0.076 W/kg
MODN. DUTY CYCLE:	50%	SAR DRIFT DURING SCAN:	-2.65 %
DIODE COMPRESSION FACTORS (V*200):	20 / 20 / 20	PROBE BATTERY LAST CHANGED:	02/07/2008
INPUT POWER LEVEL:	4 x 30dBm	EXTRAPOLATION:	poly4

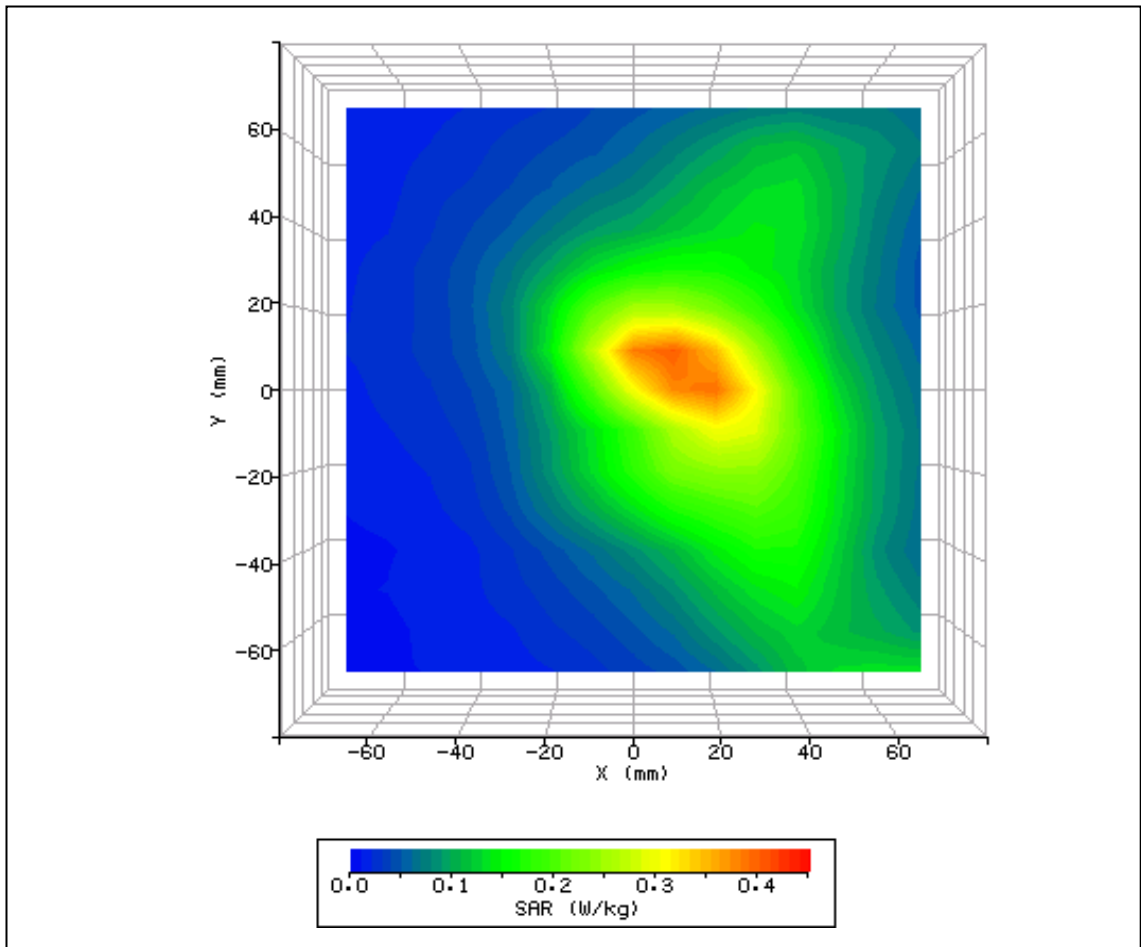

Figure 16: SAR Body Testing Results for the Option GE0421 Express Card in 10mm separation distance from bottom of flat phantom; Tested at 1880.0MHz with Host Laptop Sony Vaio VGN-TZ31MN/N in rear facing phantom configuration



2.2 MAXIMUM GPRS 1900 SAR TEST RESULT AND COURSE AREA SCAN – 2D

SYSTEM / SOFTWARE:	SARA2 / 2.53 VPM	INPUT POWER DRIFT:	0.0dB
DATE / TIME:	02/07/2008 23:54:25	DUT BATTERY MODEL/NO:	N/A
FILENAME:	75903886-251000-19.txt	PROBE SERIAL NUMBER:	0187
AMBIENT TEMPERATURE:	23.1°C	LIQUID SIMULANT:	1900 Body
DEVICE UNDER TEST:	GE0421	RELATIVE PERMITTIVITY:	54.09
RELATIVE HUMIDITY:	35.2%	CONDUCTIVITY:	1.562
PHANTOM S/NO:	HeadBox01.csv	LIQUID TEMPERATURE:	21.8°C
PHANTOM ROTATION:	0°	MAX SAR X-AXIS LOCATION:	30.00 mm
DUT POSITION:	Rear Facing 10mm separation	MAX SAR Y-AXIS LOCATION:	4.00 mm
ANTENNA CONFIGURATION:	Internal Fixed	MAX E FIELD:	16.37 V/m
TEST FREQUENCY:	1850.2MHz	SAR 1g:	0.513 W/kg
AIR FACTORS:	346 / 439 / 415	SAR 10g:	0.301 W/kg
CONVERSION FACTORS:	0.440 / 0.440 / 0.440	SAR START:	0.072 W/kg
TYPE OF MODULATION:	GMSK (GPRS)	SAR END:	0.072 W/kg
MODN. DUTY CYCLE:	50%	SAR DRIFT DURING SCAN:	-0.33 %
DIODE COMPRESSION FACTORS (V*200):	20 / 20 / 20	PROBE BATTERY LAST CHANGED:	02/07/2008
INPUT POWER LEVEL:	4 x 30dBm	EXTRAPOLATION:	poly4

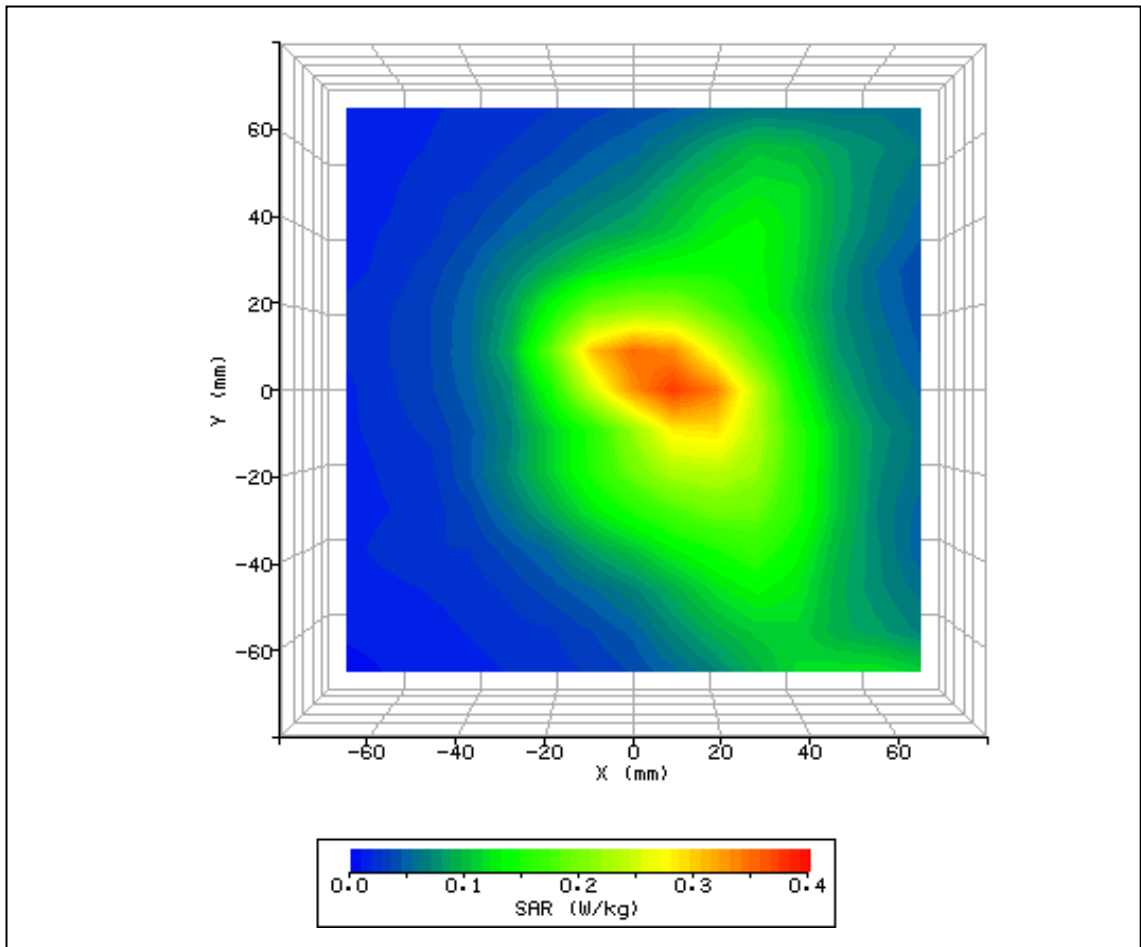

Figure 17: SAR Body Testing Results for the Option GE0421 Express Card in 10mm separation distance from bottom of flat phantom; Tested at 1850.2MHz with Host Laptop Sony Vaio VGN-TZ31MN/N in rear facing phantom configuration



2.2 MAXIMUM GPRS 1900 SAR TEST RESULT AND COURSE AREA SCAN – 2D

SYSTEM / SOFTWARE:	SARA2 / 2.53 VPM	INPUT POWER DRIFT:	0.0dB
DATE / TIME:	03/07/2008 00:26:18	DUT BATTERY MODEL/NO:	N/A
FILENAME:	75903886-251000-20.txt	PROBE SERIAL NUMBER:	0187
AMBIENT TEMPERATURE:	23.0°C	LIQUID SIMULANT:	1900 Body
DEVICE UNDER TEST:	GE0421	RELATIVE PERMITTIVITY:	54.09
RELATIVE HUMIDITY:	26.7%	CONDUCTIVITY:	1.562
PHANTOM S/NO:	HeadBox01.csv	LIQUID TEMPERATURE:	21.9°C
PHANTOM ROTATION:	0°	MAX SAR X-AXIS LOCATION:	30.00 mm
DUT POSITION:	Rear Facing 10mm separation	MAX SAR Y-AXIS LOCATION:	1.00 mm
ANTENNA CONFIGURATION:	Internal Fixed	MAX E FIELD:	17.82 V/m
TEST FREQUENCY:	1909.8MHz	SAR 1g:	0.615 W/kg
AIR FACTORS:	346 / 439 / 415	SAR 10g:	0.358 W/kg
CONVERSION FACTORS:	0.440 / 0.440 / 0.440	SAR START:	0.082 W/kg
TYPE OF MODULATION:	GMSK (GPRS)	SAR END:	0.081 W/kg
MODN. DUTY CYCLE:	50%	SAR DRIFT DURING SCAN:	-1.99 %
DIODE COMPRESSION FACTORS (V*200):	20 / 20 / 20	PROBE BATTERY LAST CHANGED:	02/07/2008
INPUT POWER LEVEL:	4 x 30dBm	EXTRAPOLATION:	poly4

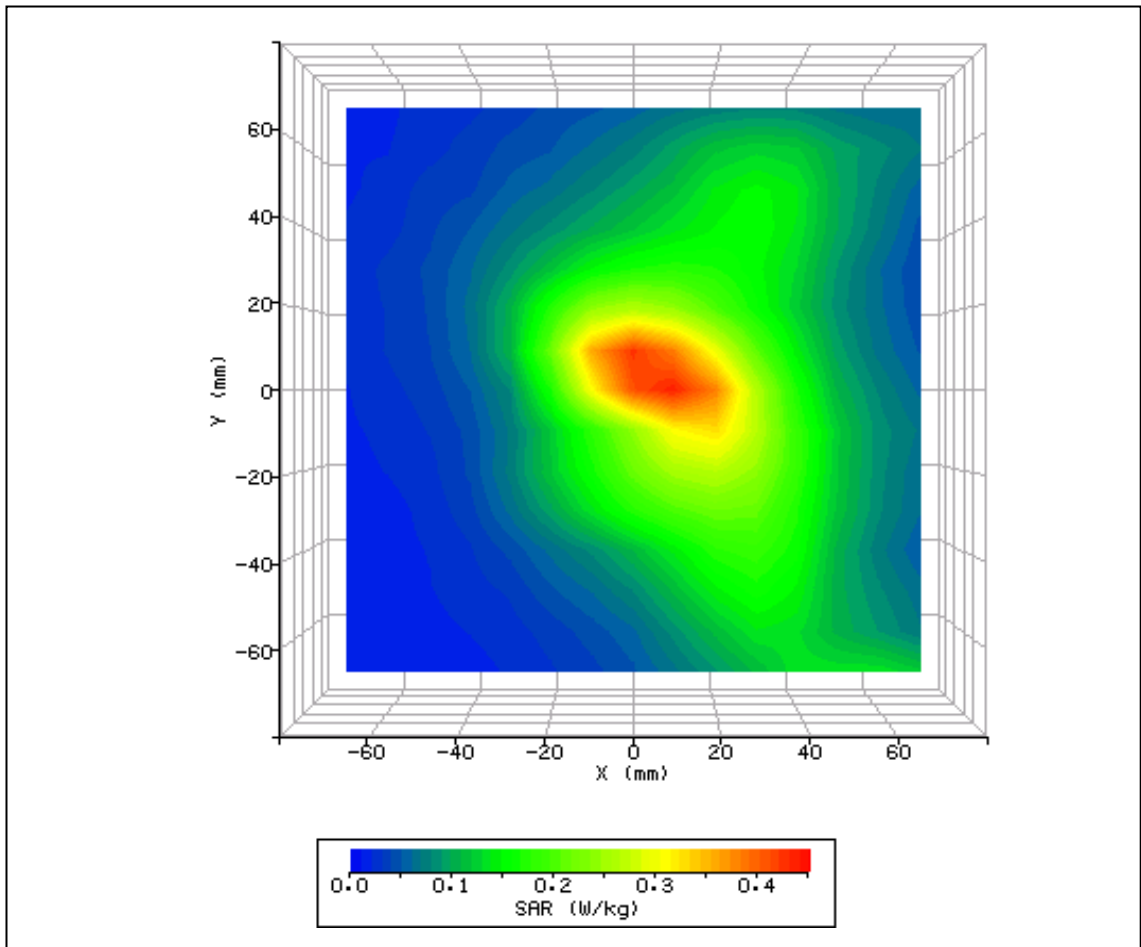

Figure 18: SAR Body Testing Results for the Option GE0421 Express Card in 10mm separation distance from bottom of flat phantom; Tested at 1909.8MHz with Host Laptop Sony Vaio VGN-TZ31MN/N in rear facing phantom configuration



2.2 MAXIMUM EGPRS 1900 SAR TEST RESULT AND COURSE AREA SCAN – 2D

SYSTEM / SOFTWARE:	SARA2 / 2.53 VPM	INPUT POWER DRIFT:	0.0dB
DATE / TIME:	03/07/2008 00:59:28	DUT BATTERY MODEL/NO:	N/A
FILENAME:	75903886-251000-21.txt	PROBE SERIAL NUMBER:	0187
AMBIENT TEMPERATURE:	23.5°C	LIQUID SIMULANT:	1900 Body
DEVICE UNDER TEST:	GE0421	RELATIVE PERMITTIVITY:	54.09
RELATIVE HUMIDITY:	40.8%	CONDUCTIVITY:	1.562
PHANTOM S/NO:	HeadBox01.csv	LIQUID TEMPERATURE:	21.9°C
PHANTOM ROTATION:	0°	MAX SAR X-AXIS LOCATION:	30.00 mm
DUT POSITION:	Rear Facing 10mm separation	MAX SAR Y-AXIS LOCATION:	2.00 mm
ANTENNA CONFIGURATION:	Internal Fixed	MAX E FIELD:	13.03 V/m
TEST FREQUENCY:	1909.8MHz	SAR 1g:	0.325 W/kg
AIR FACTORS:	346 / 439 / 415	SAR 10g:	0.187 W/kg
CONVERSION FACTORS:	0.440 / 0.440 / 0.440	SAR START:	0.044 W/kg
TYPE OF MODULATION:	GMSK (EGPRS)	SAR END:	0.044 W/kg
MODN. DUTY CYCLE:	50%	SAR DRIFT DURING SCAN:	-0.29 %
DIODE COMPRESSION FACTORS (V*200):	20 / 20 / 20	PROBE BATTERY LAST CHANGED:	02/07/2008
INPUT POWER LEVEL:	4 x 30dBm	EXTRAPOLATION:	poly4

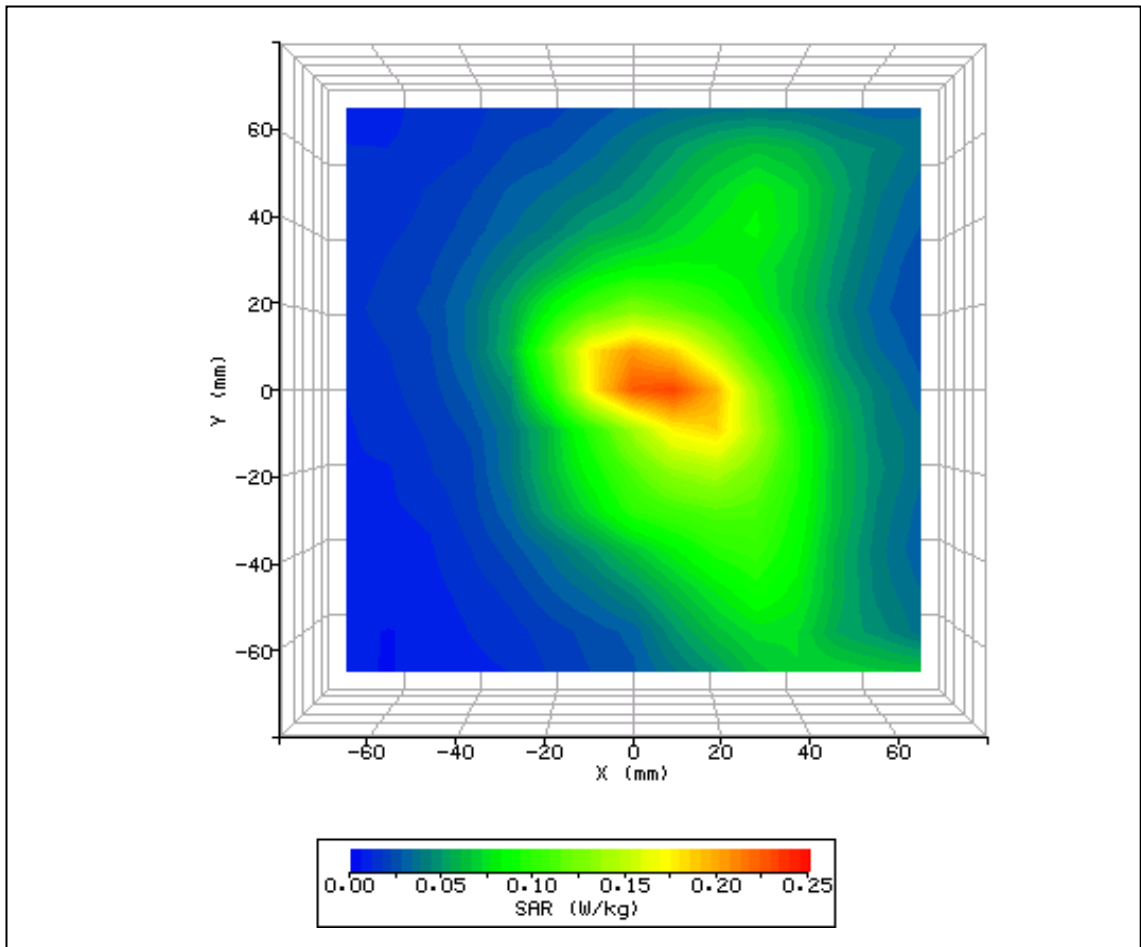

Figure 19: SAR Body Testing Results for the Option GE0421 Express Card in 10mm separation distance from bottom of flat phantom; Tested at 1909.8MHz with Host Laptop Sony Vaio VGN-TZ31MN/N in rear facing phantom configuration



2.2 MAXIMUM FDD II RMC SAR TEST RESULT AND COURSE AREA SCAN – 2D

SYSTEM / SOFTWARE:	SARA2 / 2.53 VPM	INPUT POWER DRIFT:	0.0dB
DATE / TIME:	03/07/2008 05:05:50	DUT BATTERY MODEL/NO:	N/A
FILENAME:	75903886-251000-9.txt	PROBE SERIAL NUMBER:	0187
AMBIENT TEMPERATURE:	22.6°C	LIQUID SIMULANT:	1900 Body
DEVICE UNDER TEST:	GE0421 with adapter	RELATIVE PERMITTIVITY:	54.09
RELATIVE HUMIDITY:	32.9%	CONDUCTIVITY:	1.562
PHANTOM S/NO:	HeadBox01.csv	LIQUID TEMPERATURE:	22.4°C
PHANTOM ROTATION:	0°	MAX SAR X-AXIS LOCATION:	-3.00 mm
DUT POSITION:	Rear Facing 10mm separation	MAX SAR Y-AXIS LOCATION:	-8.00 mm
ANTENNA CONFIGURATION:	Internal Fixed	MAX E FIELD:	13.72 V/m
TEST FREQUENCY:	1852.4MHz	SAR 1g:	0.359 W/kg
AIR FACTORS:	346 / 439 / 415	SAR 10g:	0.219 W/kg
CONVERSION FACTORS:	0.440 / 0.440 / 0.440	SAR START:	0.069 W/kg
TYPE OF MODULATION:	QPSK (RMC)	SAR END:	0.071 W/kg
MODN. DUTY CYCLE:	100%	SAR DRIFT DURING SCAN:	2.64 %
DIODE COMPRESSION FACTORS (V*200):	20 / 20 / 20	PROBE BATTERY LAST CHANGED:	02/07/2008
INPUT POWER LEVEL:	Max	EXTRAPOLATION:	poly4

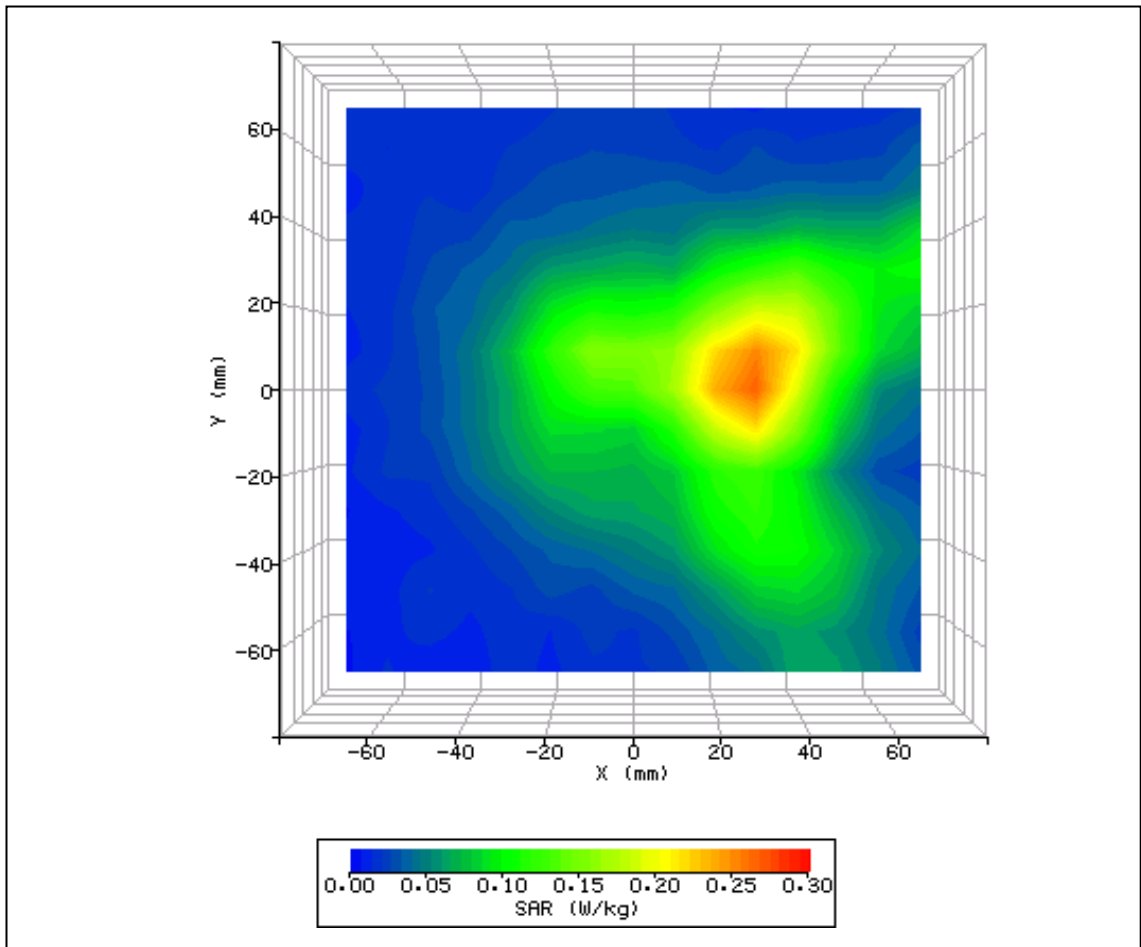

Figure 20: SAR Body Testing Results for the Option GE0421 Express Card with adapter in 10mm separation distance from bottom of flat phantom; Tested at 1852.4MHz with Host Laptop HP Compaq nc 6320 in rear facing phantom configuration



2.2 MAXIMUM FDD II RMC SAR TEST RESULT AND COURSE AREA SCAN – 2D

SYSTEM / SOFTWARE:	SARA2 / 2.53 VPM	INPUT POWER DRIFT:	0.0dB
DATE / TIME:	03/07/2008 05:34:36	DUT BATTERY MODEL/NO:	N/A
FILENAME:	75903886-251000-10.txt	PROBE SERIAL NUMBER:	0187
AMBIENT TEMPERATURE:	22.5°C	LIQUID SIMULANT:	1900 Body
DEVICE UNDER TEST:	GE0421 with adapter	RELATIVE PERMITTIVITY:	54.09
RELATIVE HUMIDITY:	33.1%	CONDUCTIVITY:	1.562
PHANTOM S/NO:	HeadBox01.csv	LIQUID TEMPERATURE:	22.4°C
PHANTOM ROTATION:	0°	MAX SAR X-AXIS LOCATION:	29.00 mm
DUT POSITION:	Rear Facing 10mm separation	MAX SAR Y-AXIS LOCATION:	6.00 mm
ANTENNA CONFIGURATION:	Internal Fixed	MAX E FIELD:	16.11 V/m
TEST FREQUENCY:	1880.0MHz	SAR 1g:	0.492 W/kg
AIR FACTORS:	346 / 439 / 415	SAR 10g:	0.300 W/kg
CONVERSION FACTORS:	0.440 / 0.440 / 0.440	SAR START:	0.091 W/kg
TYPE OF MODULATION:	QPSK (RMC)	SAR END:	0.091 W/kg
MODN. DUTY CYCLE:	100%	SAR DRIFT DURING SCAN:	0.68 %
DIODE COMPRESSION FACTORS (V*200):	20 / 20 / 20	PROBE BATTERY LAST CHANGED:	02/07/2008
INPUT POWER LEVEL:	Max	EXTRAPOLATION:	poly4

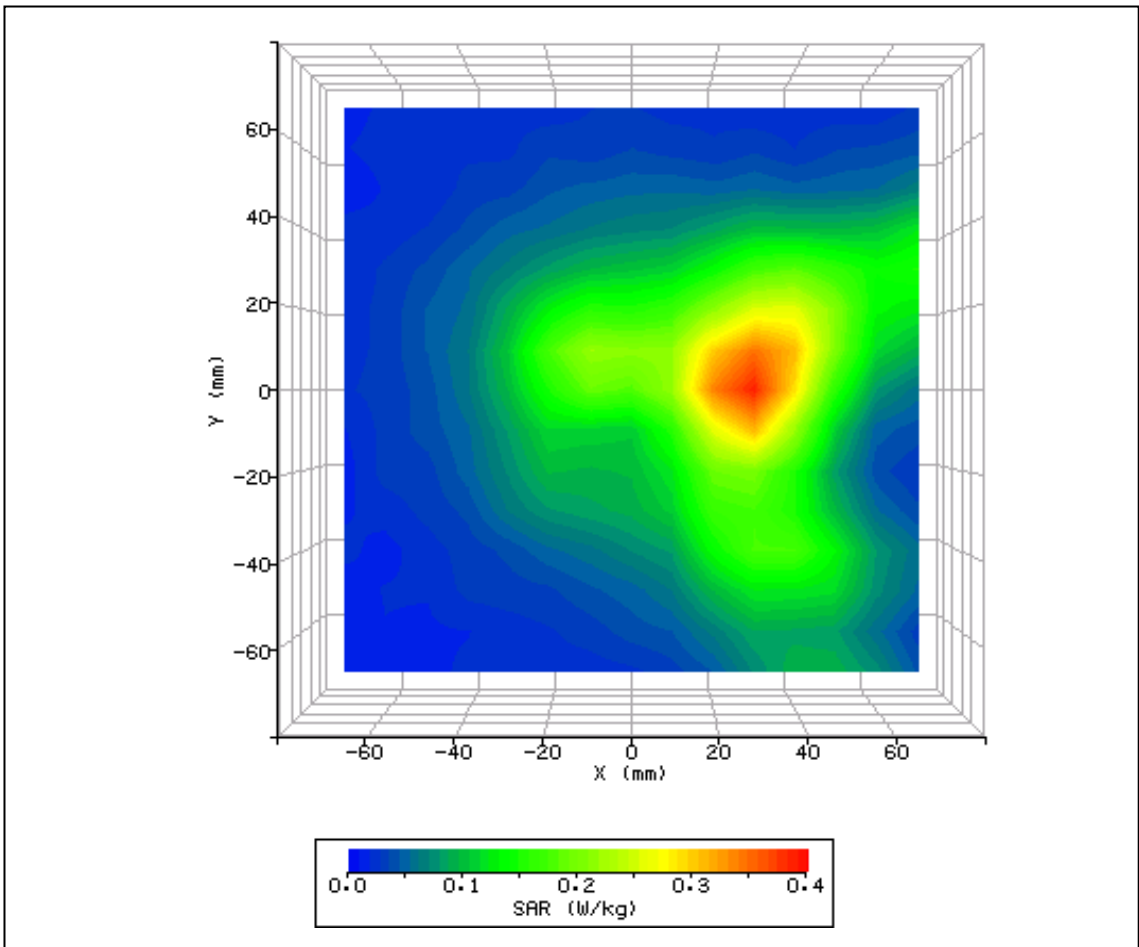

Figure 21: SAR Body Testing Results for the Option GE0421 Express Card with adapter in 10mm separation distance from bottom of flat phantom; Tested at 1880.0MHz with Host Laptop HP Compaq nc 6320 in rear facing phantom configuration



2.2 MAXIMUM FDD II RMC SAR TEST RESULT AND COURSE AREA SCAN – 2D

SYSTEM / SOFTWARE:	SARA2 / 2.53 VPM	INPUT POWER DRIFT:	0.0dB
DATE / TIME:	03/07/2008 08:17:09	DUT BATTERY MODEL/NO:	N/A
FILENAME:	75903886-251000-11.txt	PROBE SERIAL NUMBER:	0187
AMBIENT TEMPERATURE:	22.5°C	LIQUID SIMULANT:	1900 Body
DEVICE UNDER TEST:	GE0421 with adapter	RELATIVE PERMITTIVITY:	54.09
RELATIVE HUMIDITY:	36.2%	CONDUCTIVITY:	1.562
PHANTOM S/NO:	HeadBox01.csv	LIQUID TEMPERATURE:	22.4°C
PHANTOM ROTATION:	0°	MAX SAR X-AXIS LOCATION:	-4.00 mm
DUT POSITION:	Rear Facing 10mm separation	MAX SAR Y-AXIS LOCATION:	8.00 mm
ANTENNA CONFIGURATION:	Internal Fixed	MAX E FIELD:	12.66 V/m
TEST FREQUENCY:	1907.6MHz	SAR 1g:	0.315 W/kg
AIR FACTORS:	346 / 439 / 415	SAR 10g:	0.187 W/kg
CONVERSION FACTORS:	0.440 / 0.440 / 0.440	SAR START:	0.053 W/kg
TYPE OF MODULATION:	QPSK (RMC)	SAR END:	0.053 W/kg
MODN. DUTY CYCLE:	100%	SAR DRIFT DURING SCAN:	-1.12 %
DIODE COMPRESSION FACTORS (V*200):	20 / 20 / 20	PROBE BATTERY LAST CHANGED:	02/07/2008
INPUT POWER LEVEL:	Max	EXTRAPOLATION:	poly4

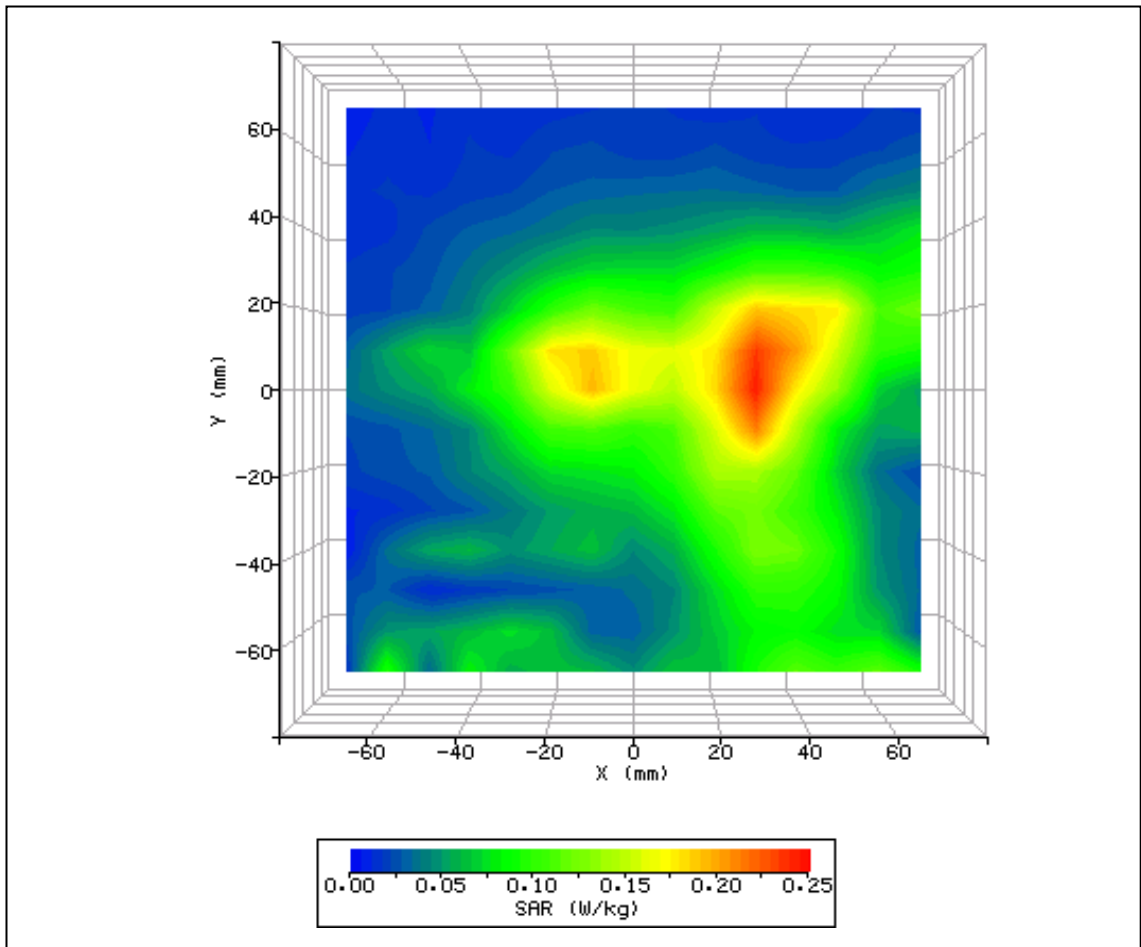

Figure 22: SAR Body Testing Results for the Option GE0421 Express Card with adapter in 10mm separation distance from bottom of flat phantom; Tested at 1907.6MHz with Host Laptop HP Compaq nc 6320 in rear facing phantom configuration



2.2 MAXIMUM FDD II HSDPA (Sub-test 2) SAR TEST RESULT AND COURSE AREA SCAN – 2D

SYSTEM / SOFTWARE:	SARA2 / 2.53 VPM	INPUT POWER DRIFT:	0.0dB
DATE / TIME:	03/07/2008 09:16:35	DUT BATTERY MODEL/NO:	N/A
FILENAME:	75903886-251000-12.txt	PROBE SERIAL NUMBER:	0187
AMBIENT TEMPERATURE:	22.4°C	LIQUID SIMULANT:	1900 Body
DEVICE UNDER TEST:	GE0421 with adapter	RELATIVE PERMITTIVITY:	54.09
RELATIVE HUMIDITY:	37.2%	CONDUCTIVITY:	1.562
PHANTOM S/NO:	HeadBox01.csv	LIQUID TEMPERATURE:	22.3°C
PHANTOM ROTATION:	0°	MAX SAR X-AXIS LOCATION:	-3.00 mm
DUT POSITION:	Rear Facing 10mm separation	MAX SAR Y-AXIS LOCATION:	8.00 mm
ANTENNA CONFIGURATION:	Internal Fixed	MAX E FIELD:	13.76 V/m
TEST FREQUENCY:	1880.0MHz	SAR 1g:	0.336 W/kg
AIR FACTORS:	346 / 439 / 415	SAR 10g:	0.223 W/kg
CONVERSION FACTORS:	0.440 / 0.440 / 0.440	SAR START:	0.066 W/kg
TYPE OF MODULATION:	QPSK (HSDPA + RMC)	SAR END:	0.069 W/kg
MODN. DUTY CYCLE:	100%	SAR DRIFT DURING SCAN:	-4.34 %
DIODE COMPRESSION FACTORS (V*200):	20 / 20 / 20	PROBE BATTERY LAST CHANGED:	02/07/2008
INPUT POWER LEVEL:	Max	EXTRAPOLATION:	poly4

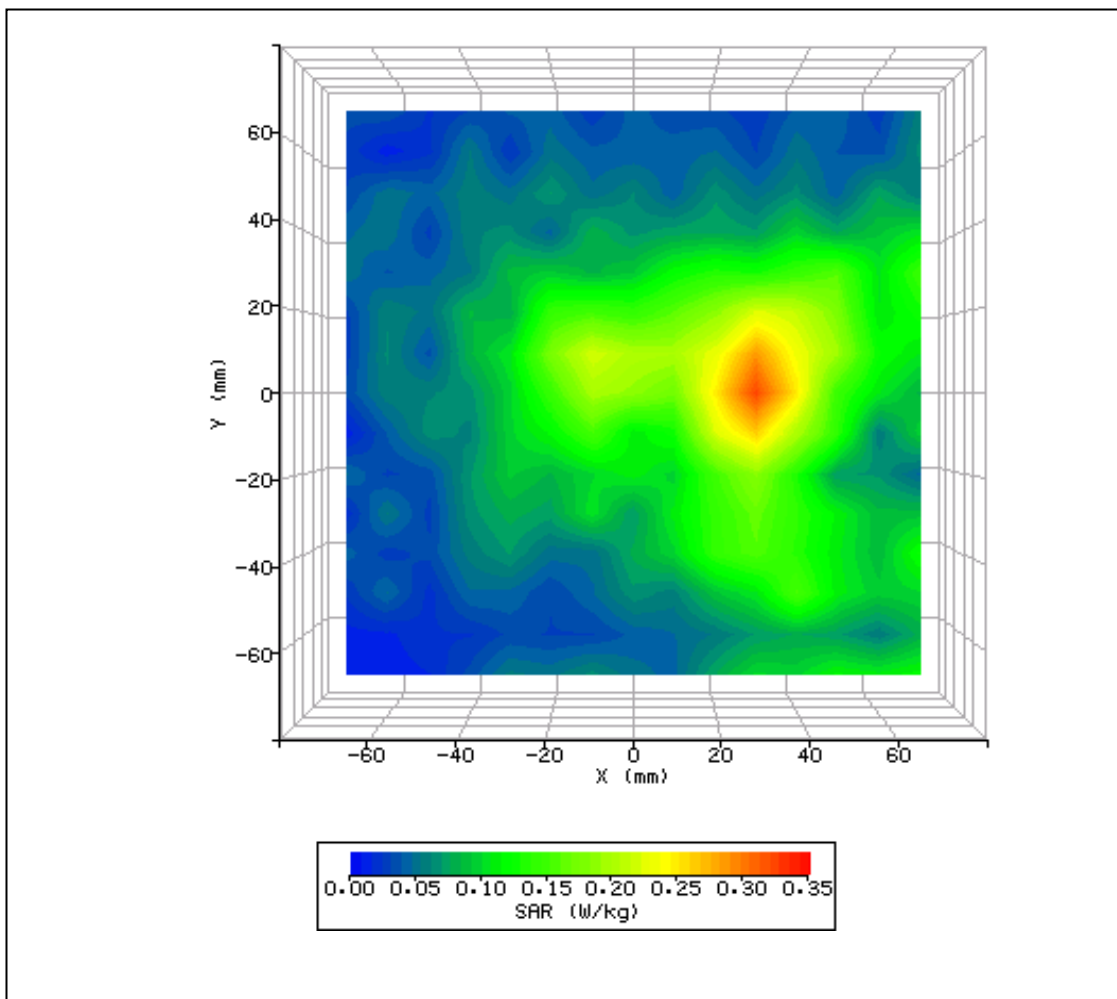

Figure 23: SAR Body SAR Body Testing Results for the Option GE0421 Express Card with adapter in 10mm separation distance from bottom of flat phantom; Tested at 1880.0MHz (HSDPA sub-test 2 + RMC) with Host Laptop HP Compaq nc 6320 in rear facing phantom configuration



2.2 MAXIMUM FDD II HSUPA (Sub-test 5) SAR TEST RESULT AND COURSE AREA SCAN – 2D

SYSTEM / SOFTWARE:	SARA2 / 2.53 VPM	INPUT POWER DRIFT:	0.0dB
DATE / TIME:	03/07/2008 09:51:23	DUT BATTERY MODEL/NO:	N/A
FILENAME:	75903886-251000-13.txt	PROBE SERIAL NUMBER:	0187
AMBIENT TEMPERATURE:	22.3°C	LIQUID SIMULANT:	1900 Body
DEVICE UNDER TEST:	GE0421 with adapter	RELATIVE PERMITTIVITY:	54.09
RELATIVE HUMIDITY:	36.5%	CONDUCTIVITY:	1.562
PHANTOM S/NO:	HeadBox01.csv	LIQUID TEMPERATURE:	22.3°C
PHANTOM ROTATION:	0°	MAX SAR X-AXIS LOCATION:	12.00 mm
DUT POSITION:	Rear Facing 10mm separation	MAX SAR Y-AXIS LOCATION:	5.00 mm
ANTENNA CONFIGURATION:	Internal Fixed	MAX E FIELD:	13.27 V/m
TEST FREQUENCY:	1880.0MHz	SAR 1g:	0.305 W/kg
AIR FACTORS:	346 / 439 / 415	SAR 10g:	0.201 W/kg
CONVERSION FACTORS:	0.440 / 0.440 / 0.440	SAR START:	0.059 W/kg
TYPE OF MODULATION:	QPSK (HSUPA + RMC)	SAR END:	0.060 W/kg
MODN. DUTY CYCLE:	100%	SAR DRIFT DURING SCAN:	1.66 %
DIODE COMPRESSION FACTORS (V*200):	20 / 20 / 20	PROBE BATTERY LAST CHANGED:	02/07/2008
INPUT POWER LEVEL:	Max	EXTRAPOLATION:	poly4

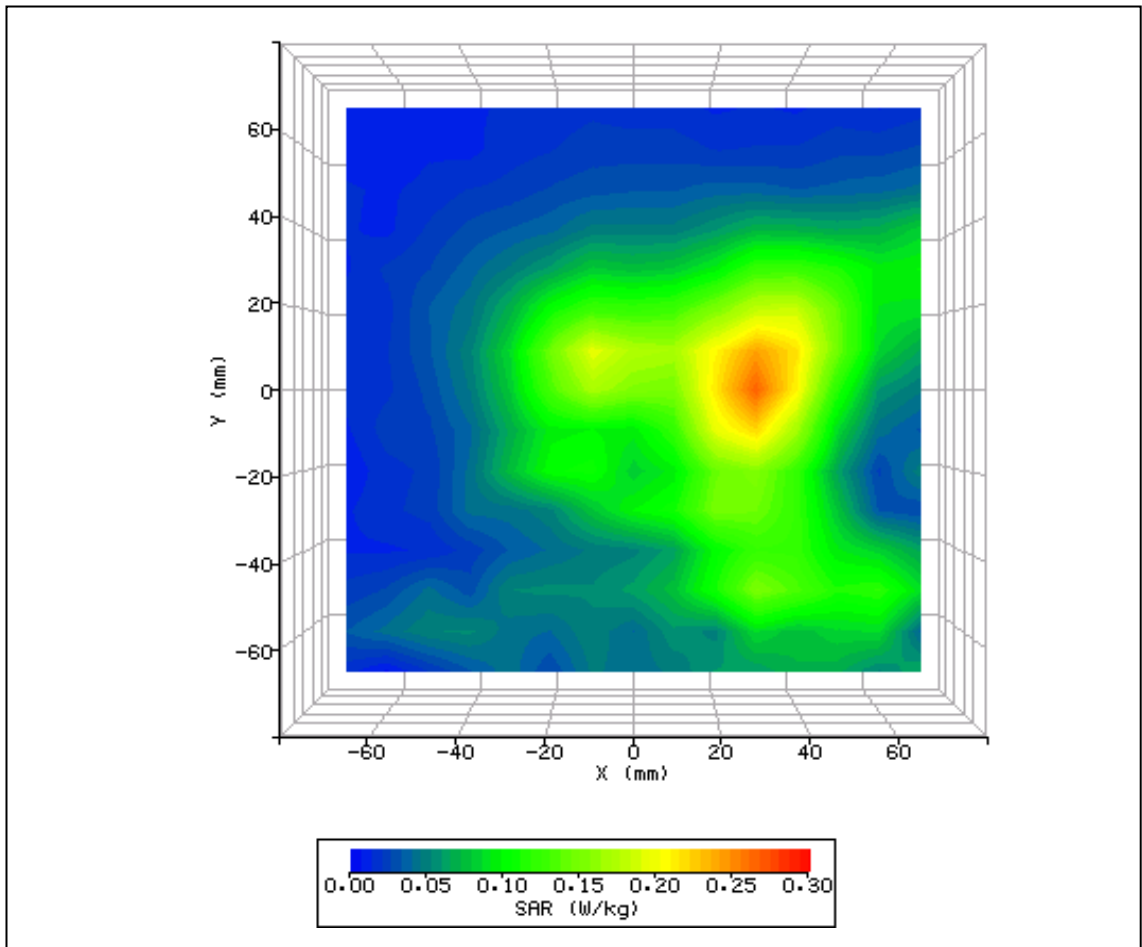

Figure 24: SAR Body SAR Body Testing Results for the Option GE0421 Express Card with adapter in 10mm separation distance from bottom of flat phantom; Tested at 1880.0MHz (HSUPA sub-test 5 + RMC) with Host Laptop HP Compaq nc 6320 in rear facing phantom configuration



2.2 MAXIMUM FDD II RMC SAR TEST RESULT AND COURSE AREA SCAN – 2D

SYSTEM / SOFTWARE:	SARA2 / 2.53 VPM	INPUT POWER DRIFT:	0.0dB
DATE / TIME:	03/07/2008 01:45:12	DUT BATTERY MODEL/NO:	N/A
FILENAME:	75903886-251000-22.txt	PROBE SERIAL NUMBER:	0187
AMBIENT TEMPERATURE:	22.9°C	LIQUID SIMULANT:	1900 Body
DEVICE UNDER TEST:	GE0421	RELATIVE PERMITTIVITY:	54.09
RELATIVE HUMIDITY:	38.9%	CONDUCTIVITY:	1.562
PHANTOM S/NO:	HeadBox01.csv	LIQUID TEMPERATURE:	22.5°C
PHANTOM ROTATION:	0°	MAX SAR X-AXIS LOCATION:	15.00 mm
DUT POSITION:	Rear Facing 10mm separation	MAX SAR Y-AXIS LOCATION:	2.00 mm
ANTENNA CONFIGURATION:	Internal Fixed	MAX E FIELD:	12.24 V/m
TEST FREQUENCY:	1852.4MHz	SAR 1g:	0.291 W/kg
AIR FACTORS:	346 / 439 / 415	SAR 10g:	0.178 W/kg
CONVERSION FACTORS:	0.440 / 0.440 / 0.440	SAR START:	0.046 W/kg
TYPE OF MODULATION:	QPSK (RMC)	SAR END:	0.046 W/kg
MODN. DUTY CYCLE:	100%	SAR DRIFT DURING SCAN:	0.33 %
DIODE COMPRESSION FACTORS (V*200):	20 / 20 / 20	PROBE BATTERY LAST CHANGED:	02/07/2008
INPUT POWER LEVEL:	Max	EXTRAPOLATION:	poly4

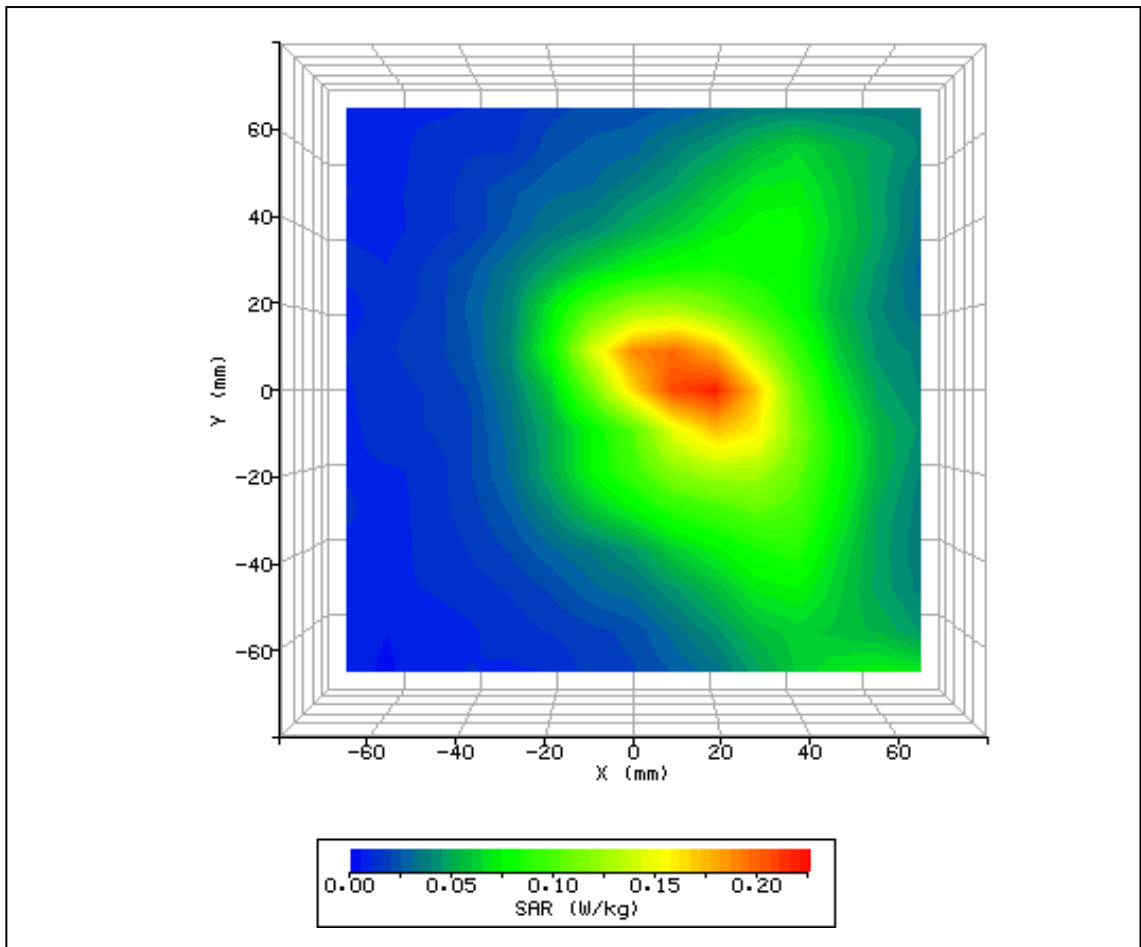

Figure 25: SAR Body Testing Results for the Option GE0421 Express Card in 10mm separation distance from bottom of flat phantom; Tested at 1852.4MHz with Host Laptop Sony Vaio VGN-TZ31MN/N in rear facing phantom configuration



2.2 MAXIMUM FDD II RMC SAR TEST RESULT AND COURSE AREA SCAN – 2D

SYSTEM / SOFTWARE:	SARA2 / 2.53 VPM	INPUT POWER DRIFT:	0.0dB
DATE / TIME:	03/07/2008 02:09:20	DUT BATTERY MODEL/NO:	N/A
FILENAME:	75903886-251000-23.txt	PROBE SERIAL NUMBER:	0187
AMBIENT TEMPERATURE:	23.0°C	LIQUID SIMULANT:	1900 Body
DEVICE UNDER TEST:	GE0421	RELATIVE PERMITTIVITY:	54.09
RELATIVE HUMIDITY:	41.1%	CONDUCTIVITY:	1.562
PHANTOM S/NO:	HeadBox01.csv	LIQUID TEMPERATURE:	22.5°C
PHANTOM ROTATION:	0°	MAX SAR X-AXIS LOCATION:	18.00 mm
DUT POSITION:	Rear Facing 10mm separation	MAX SAR Y-AXIS LOCATION:	0.00 mm
ANTENNA CONFIGURATION:	Internal Fixed	MAX E FIELD:	14.72 V/m
TEST FREQUENCY:	1880.0MHz	SAR 1g:	0.417 W/kg
AIR FACTORS:	346 / 439 / 415	SAR 10g:	0.254 W/kg
CONVERSION FACTORS:	0.440 / 0.440 / 0.440	SAR START:	0.065 W/kg
TYPE OF MODULATION:	QPSK (RMC)	SAR END:	0.065 W/kg
MODN. DUTY CYCLE:	100%	SAR DRIFT DURING SCAN:	0.20 %
DIODE COMPRESSION FACTORS (V*200):	20 / 20 / 20	PROBE BATTERY LAST CHANGED:	02/07/2008
INPUT POWER LEVEL:	Max	EXTRAPOLATION:	poly4

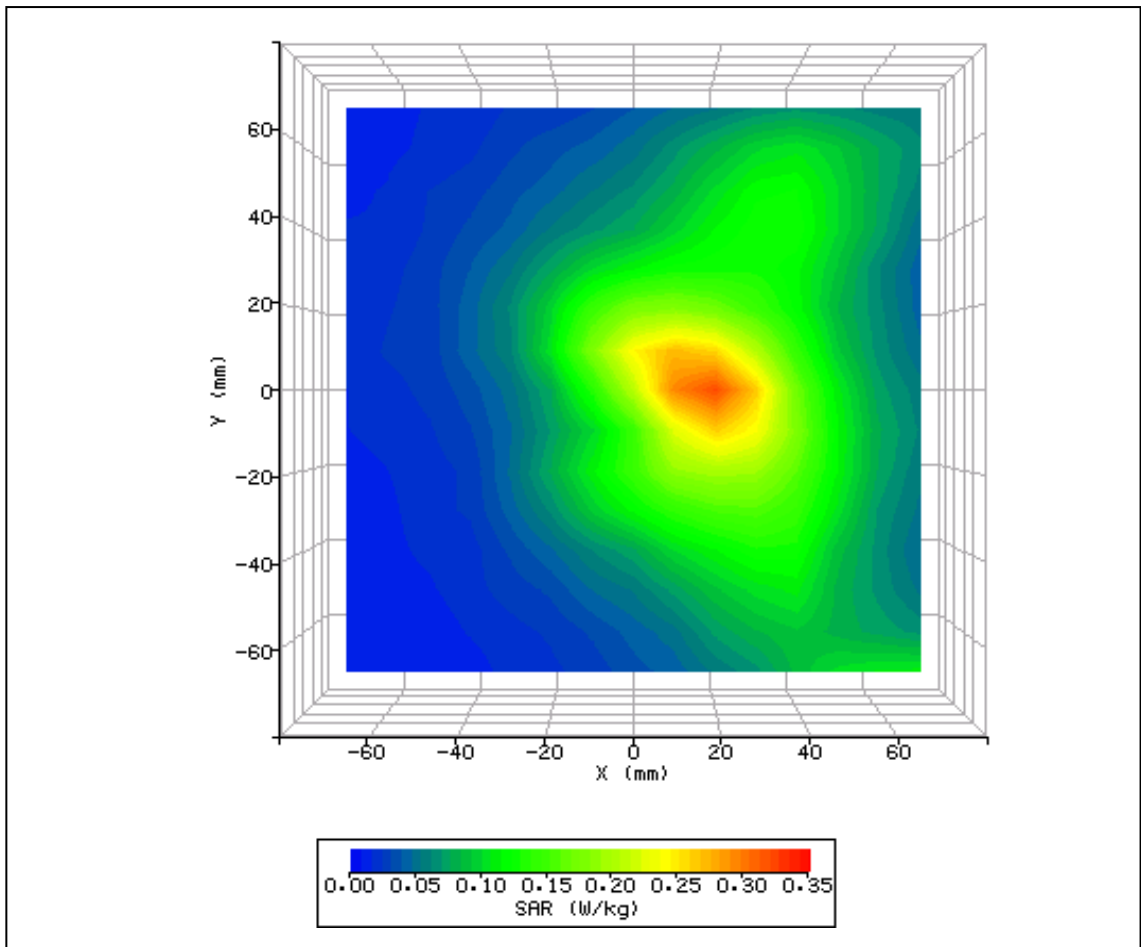

Figure 26: SAR Body Testing Results for the Option GE0421 Express Card in 10mm separation distance from bottom of flat phantom; Tested at 1880.0MHz with Host Laptop Sony Vaio VGN-TZ31MN/N in rear facing phantom configuration



2.2 MAXIMUM FDD II RMC SAR TEST RESULT AND COURSE AREA SCAN – 2D

SYSTEM / SOFTWARE:	SARA2 / 2.53 VPM	INPUT POWER DRIFT:	0.0dB
DATE / TIME:	03/07/2008 02:37:01	DUT BATTERY MODEL/NO:	N/A
FILENAME:	75903886-251000-24.txt	PROBE SERIAL NUMBER:	0187
AMBIENT TEMPERATURE:	23.1°C	LIQUID SIMULANT:	1900 Body
DEVICE UNDER TEST:	GE0421	RELATIVE PERMITTIVITY:	54.09
RELATIVE HUMIDITY:	39.1%	CONDUCTIVITY:	1.562
PHANTOM S/NO:	HeadBox01.csv	LIQUID TEMPERATURE:	22.5°C
PHANTOM ROTATION:	0°	MAX SAR X-AXIS LOCATION:	19.00 mm
DUT POSITION:	Rear Facing 10mm separation	MAX SAR Y-AXIS LOCATION:	0.00 mm
ANTENNA CONFIGURATION:	Internal Fixed	MAX E FIELD:	12.49 V/m
TEST FREQUENCY:	1907.6MHz	SAR 1g:	0.303 W/kg
AIR FACTORS:	346 / 439 / 415	SAR 10g:	0.189 W/kg
CONVERSION FACTORS:	0.440 / 0.440 / 0.440	SAR START:	0.050 W/kg
TYPE OF MODULATION:	QPSK (RMC)	SAR END:	0.050 W/kg
MODN. DUTY CYCLE:	100%	SAR DRIFT DURING SCAN:	1.26 %
DIODE COMPRESSION FACTORS (V*200):	20 / 20 / 20	PROBE BATTERY LAST CHANGED:	02/07/2008
INPUT POWER LEVEL:	Max	EXTRAPOLATION:	poly4

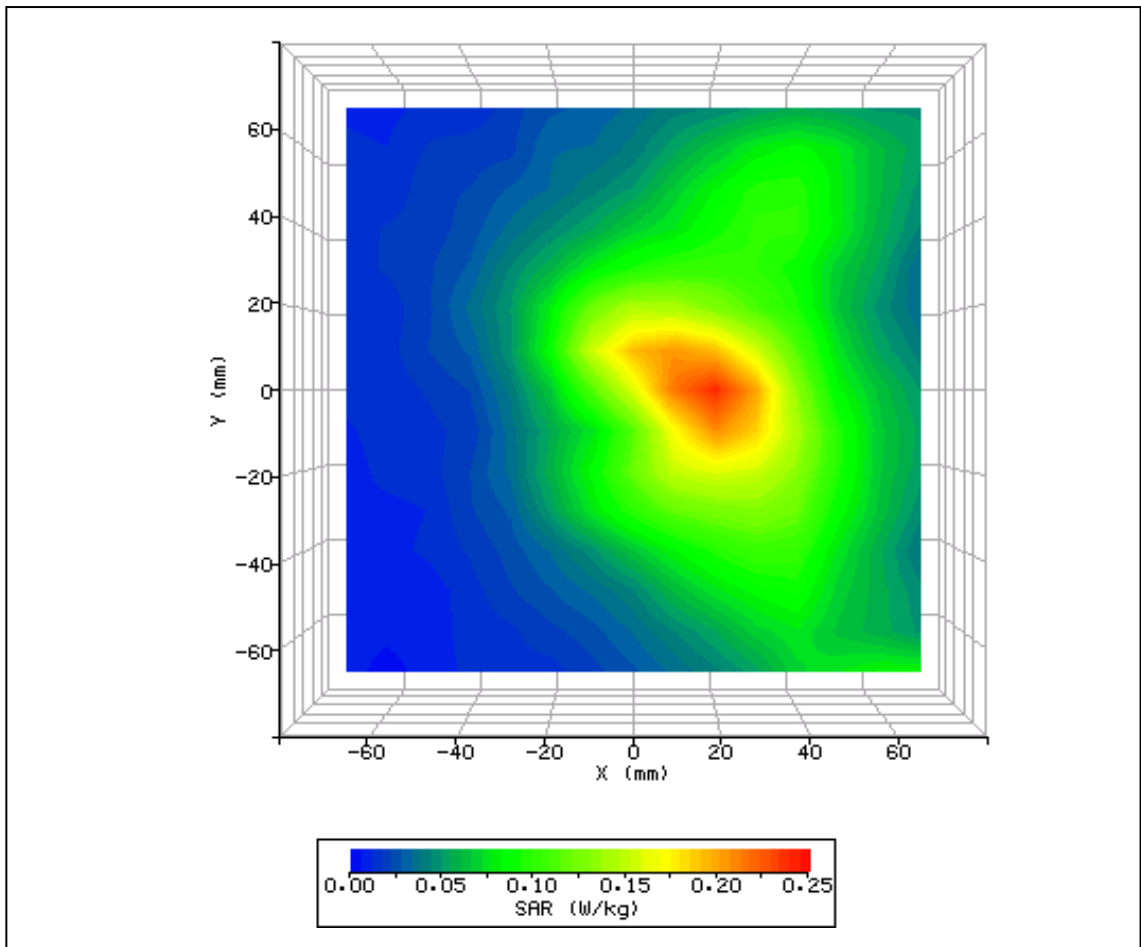

Figure 27: SAR Body Testing Results for the Option GE0421 Express Card in 10mm separation distance from bottom of flat phantom; Tested at 1907.6MHz with Host Laptop Sony Vaio VGN-TZ31MN/N in rear facing phantom configuration



2.2 MAXIMUM FDD II HSDPA (Sub-test 2) SAR TEST RESULT AND COURSE AREA SCAN – 2D

SYSTEM / SOFTWARE:	SARA2 / 2.53 VPM	INPUT POWER DRIFT:	0.0dB
DATE / TIME:	03/07/2008 03:37:53	DUT BATTERY MODEL/NO:	N/A
FILENAME:	75903886-251000-25.txt	PROBE SERIAL NUMBER:	0187
AMBIENT TEMPERATURE:	23.1°C	LIQUID SIMULANT:	1900 Body
DEVICE UNDER TEST:	GE0421	RELATIVE PERMITTIVITY:	54.09
RELATIVE HUMIDITY:	36.6%	CONDUCTIVITY:	1.562
PHANTOM S/NO:	HeadBox01.csv	LIQUID TEMPERATURE:	22.4°C
PHANTOM ROTATION:	0°	MAX SAR X-AXIS LOCATION:	18.00 mm
DUT POSITION:	Rear Facing 10mm separation	MAX SAR Y-AXIS LOCATION:	1.00 mm
ANTENNA CONFIGURATION:	Internal Fixed	MAX E FIELD:	14.00 V/m
TEST FREQUENCY:	1880.0MHz	SAR 1g:	0.383 W/kg
AIR FACTORS:	346 / 439 / 415	SAR 10g:	0.233 W/kg
CONVERSION FACTORS:	0.440 / 0.440 / 0.440	SAR START:	0.060 W/kg
TYPE OF MODULATION:	QPSK (HSDPA + RMC)	SAR END:	0.061 W/kg
MODN. DUTY CYCLE:	100%	SAR DRIFT DURING SCAN:	1.40 %
DIODE COMPRESSION FACTORS (V*200):	20 / 20 / 20	PROBE BATTERY LAST CHANGED:	02/07/2008
INPUT POWER LEVEL:	Max	EXTRAPOLATION:	poly4

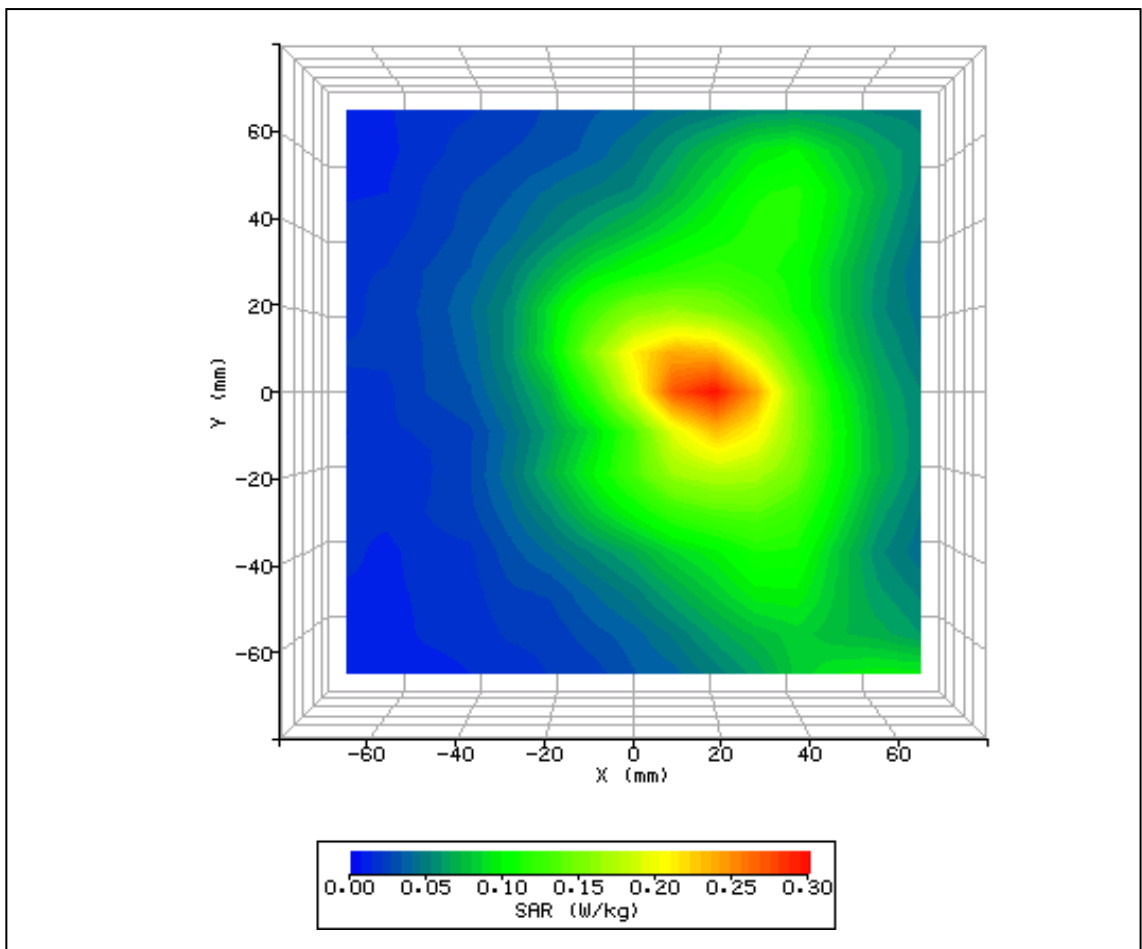

Figure 28: SAR Body SAR Body Testing Results for the Option GE0421 Express Card in 10mm separation distance from bottom of flat phantom; Tested at 1880.0MHz (HSDPA sub-test 2 + RMC) with Host Laptop Sony Vaio VGN-TZ31MN/N in rear facing phantom configuration



2.2 MAXIMUM FDD II HSUPA (Sub-test 5) SAR TEST RESULT AND COURSE AREA SCAN – 2D

SYSTEM / SOFTWARE:	SARA2 / 2.53 VPM	INPUT POWER DRIFT:	0.0dB
DATE / TIME:	03/07/2008 04:15:44	DUT BATTERY MODEL/NO:	N/A
FILENAME:	75903886-251000-26.txt	PROBE SERIAL NUMBER:	0187
AMBIENT TEMPERATURE:	22.9°C	LIQUID SIMULANT:	1900 Body
DEVICE UNDER TEST:	GE0421	RELATIVE PERMITTIVITY:	54.09
RELATIVE HUMIDITY:	29.9%	CONDUCTIVITY:	1.562
PHANTOM S/NO:	HeadBox01.csv	LIQUID TEMPERATURE:	22.4°C
PHANTOM ROTATION:	0°	MAX SAR X-AXIS LOCATION:	13.00 mm
DUT POSITION:	Rear Facing 10mm separation	MAX SAR Y-AXIS LOCATION:	0.00 mm
ANTENNA CONFIGURATION:	Internal Fixed	MAX E FIELD:	14.3 V/m
TEST FREQUENCY:	1880.0MHz	SAR 1g:	0.394 W/kg
AIR FACTORS:	346 / 439 / 415	SAR 10g:	0.24 W/kg
CONVERSION FACTORS:	0.440 / 0.440 / 0.440	SAR START:	0.062 W/kg
TYPE OF MODULATION:	QPSK (HSUPA + RMC)	SAR END:	0.063 W/kg
MODN. DUTY CYCLE:	100%	SAR DRIFT DURING SCAN:	1.73 %
DIODE COMPRESSION FACTORS (V*200):	20 / 20 / 20	PROBE BATTERY LAST CHANGED:	02/07/2008
INPUT POWER LEVEL:	Max	EXTRAPOLATION:	poly4

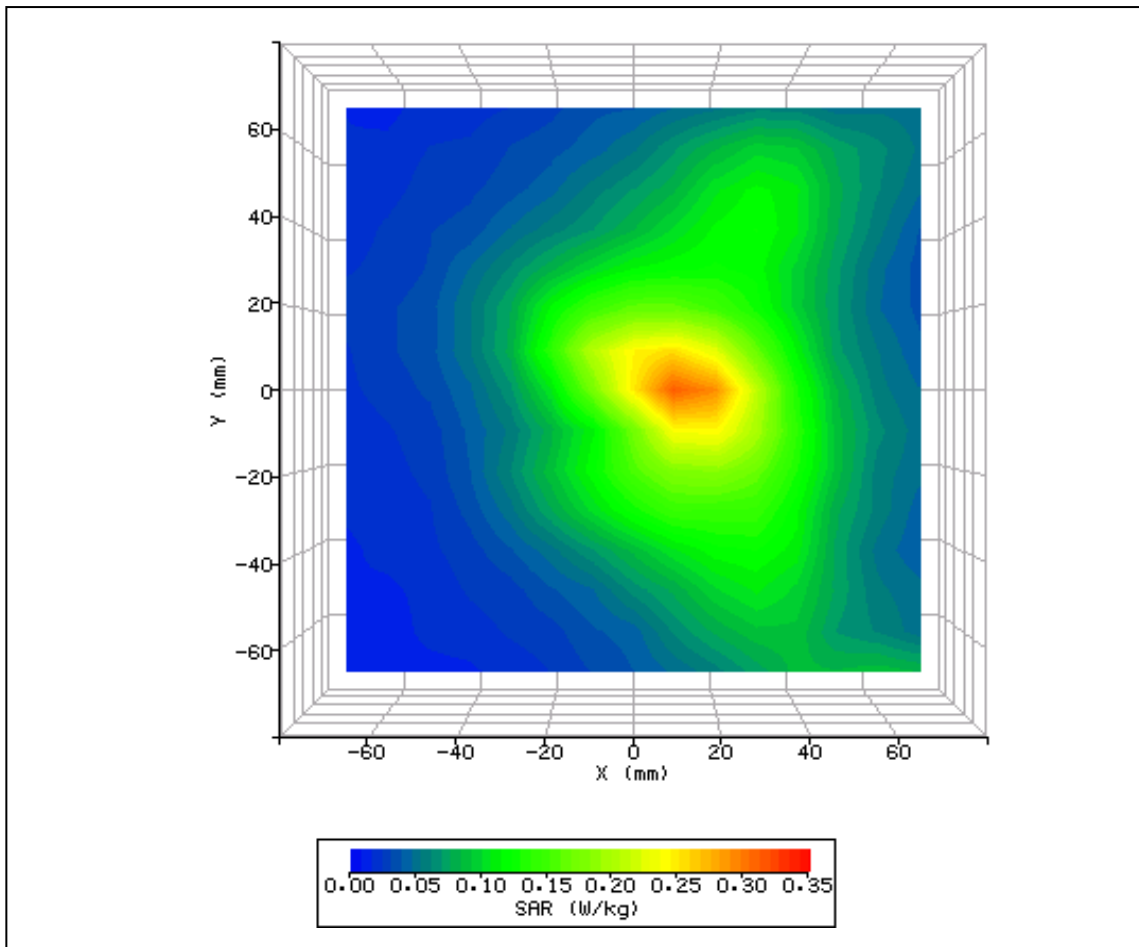

Figure 29: SAR Body SAR Body Testing Results for the Option GE0421 Express Card in 10mm separation distance from bottom of flat phantom; Tested at 1880.0MHz (HSUPA sub-test 5 + RMC) with Host Laptop Sony Vaio VGN-TZ31MN/N in rear facing phantom configuration



SECTION 3

TEST EQUIPMENT



3.1 TEST EQUIPMENT

The following test equipment was used at TUV Product Service Ltd:

Instrument	Manufacturer	Type No.	TE No.	Calibration Period (months)	Calibration Due
Signal Generator	Marconi	2031	53	12	23-Feb-2009
Power Sensor	Rohde & Schwarz	NRV-Z1	60	12	28-Nov-2008
Industrial Robot	Mitsubishi	RV-E2/CR-E116	63	-	TU
Thermometer	Digitron	T208	64	12	10-Oct-2008
Communications Tester	Rohde & Schwarz	CMU 200	442	12	05-July-2008
Attenuator (20dB, 10W)	Weinschel	37-20-34	482	12	1-Mar-2009
Fast Probe Amplifier (3	IndexSar Ltd	IFA-010	1557	-	TU
Cube Phantom	IndexSar Ltd	IXB-070	1565	-	TU
Upright Bench	IndexSar Ltd	SARA2-B2	1569	-	TU
Bi-directional Coupler	IndexSar Ltd	7401 (VDC0830-20)	2414	12	2-Feb-2009
Validation Amplifier	IndexSar Ltd	VBM2500-3	2415	12	30-Nov-2008
Hygromer	Rotronic	I-1000	2784	12	30-Jul-2008
Power Sensor	Rohde & Schwarz	NRV- Z5	2878	12	2-Jun-2009
Antenna	Katherin Scala Division	OG-890/1990/DC	2906	12	16-Nov-2008
Dual Channel Power	Rohde & Schwarz	NRVD	3259	12	15-Nov-2008
SAR Probe	IndexSAR Ltd.	IXP-050-187	3320-	12	24-Sept-2008
1900MHz Dipole	IndexSAR Ltd.	D1900	N/A	-	02-July-2008
1900MHz Dipole	IndexSAR Ltd.	D1900	N/A	-	03-July-2008
835MHz Dipole	IndexSAR Ltd.	D835	N/A	-	02-July-2008
835MHz Dipole	IndexSAR Ltd.	D835	N/A	-	03-July-2008
835MHz TEM Head	TUVPS Ltd	Batch 13	N/A	1	30-July-2008
835MHz TEM Body	TUVPS Ltd	Batch 9	N/A	1	30-July-2008
1900MHz TEM Head	TUVPS Ltd	Batch 3	N/A	1	30-July-2008
1900MHz TEM Body	TUVPS Ltd	Batch 2	N/A	1	30-July-2008

3.2 TEST SOFTWARE

The following software was used to control the BABT SARA2 System:

INSTRUMENT	VERSION NO.	DATE
SARA2 system	v.2.3.9 VPM	09/09/2005
Mitsubishi robot controller firmware revision	RV-E2 Version C9a	-
IFA-10 Probe amplifier	Version 2.5	-



3.3 DIELECTRIC PROPERTIES OF SIMULANT LIQUIDS

The fluid properties of the simulant fluids used during routine SAR evaluation meet the dielectric properties required by EN50361:2001 & OET Bulletin 65 (Edition 97-01).

The fluids were calibrated in our Laboratory and re-checked prior to any measurements being made against reference fluids stated in IEEE 1528-2003 of 0.9% NaCl (Salt Solution) at 23°C and also for Dimethylsulphoxide (DMS) at 21°C.

The fluids were made at BABT under controlled conditions from the following OET(65)c formulae and IEEE1528-2003. The composition of ingredients may have been modified accordingly to achieve the desired target tissue parameters required for routine SAR evaluation:

OET 65(c) Recipes

Ingredients (% by weight)	Frequency (MHz)									
	450		835		915		1900		2450	
Tissue Type	Head	Body	Head	Body	Head	Body	Head	Body	Head	Body
Water	38.56	51.16	41.45	52.4	41.05	56.0	54.9	40.4	62.7	73.2
Salt (NaCl)	3.95	1.49	1.45	1.4	1.35	0.76	0.18	0.5	0.5	0.04
Sugar	56.32	46.78	56.0	45.0	56.5	41.76	0.0	58.0	0.0	0.0
HEC	0.98	0.52	1.0	1.0	1.0	1.21	0.0	1.0	0.0	0.0
Bactericide	0.19	0.05	0.1	0.1	0.1	0.27	0.0	0.1	0.0	0.0
Triton X-100	0.0	0.0	0.0	0.0	0.0	0.0	0.0	0.0	36.8	0.0
DGBE	0.0	0.0	0.0	0.0	0.0	0.0	44.92	0.0	0.0	26.7
Dielectric Constant	43.42	58.0	42.54	56.1	42.0	56.8	39.9	54.0	39.8	52.5
Conductivity (S/m)	0.85	0.83	0.91	0.95	1.0	1.07	1.42	1.45	1.88	1.78

IEEE 1528 Recipes

Frequency (MHz)	300	450	835	900			1450	1800				1900	1950	2000	2100		2450			3000	
Recipe #	1	1	3	1	1	2	3	1	1	2	2	3	1	2	4	1	1	2	2	3	1
Ingredients (% by weight)																					
1,2-Propanediol							64.81														
Bactericide	0.19	0.19	0.5	0.1	0.1		0.5					0.5									0.5
Diacetin			48.9				49.2					49.43									49.75
DGBE								45.41	47	13.84	44.92		44.92	13.84	45	50	50	7.99	7.99		7.99
HEC	0.98	0.98		1	1																
NaCl	5.95	3.95	1.7	1.45	1.48	0.79	1.1	0.67	0.36	0.35	0.18	0.64	0.18	0.35					0.16	0.16	0.16
Sucrose	55.32	56.32		57	56.5																
Triton X-100										30.45				30.45						19.97	19.97
Water	37.56	38.56	48.9	40.45	40.92	34.4	49.2	53.82	52.64	55.36	54.9	49.43	54.9	55.36	55	50	50	71.88	71.88	49.75	71.88
Measured dielectric parameters																					
ϵ'_r	46	43.4	44.3	41.6	41.2	41.8	42.7	40.9	39.3	41	40.4	39.2	39.9	41	40.1	37	36.8	41.1	40.3	39.2	37.9
σ (S/m)	0.86	0.85	0.9	0.9	0.98	0.97	0.99	1.21	1.39	1.38	1.4	1.4	1.42	1.38	1.41	1.4	1.51	1.55	1.88	1.82	2.46
Temp. (°C)	22	22	20	22	22	22	20	22	22	21	22	20	21	21	20	22	22	20	20	20	20
Target dielectric parameters (Table 5-1)																					
ϵ'_r	45.3	43.5	41.5	41.5				40.5	40								39.8	39.2	38.5		
σ (S/m)	0.87	0.87	0.9	0.97				1.2	1.4								1.49	1.8	2.4		



3.3 DIELECTRIC PROPERTIES OF SIMULANT LIQUIDS

The dielectric properties of the tissue simulant liquids used for the SAR testing at BABT are as follows:-

FLUID TYPE	FREQUENCY	RELATIVE PERMITTIVITY ϵ_r (e') TARGET	RELATIVE PERMITTIVITY ϵ_r (e') MEASURED	CONDUCTIVITY σ TARGET	CONDUCTIVITY σ MEASURED
BODY	835 MHz	55.00	56.84	0.97	0.994
BODY	1900 MHz	53.30	54.09	1.52	1.562

3.4 TEST CONDITIONS

TEST LABORATORY CONDITIONS

Ambient Temperature: Within +15°C to +35°C at 20% RH to 75% RH.
 The actual Temperature during the testing ranged from 22.1°C to 23.5 °C.
 The actual Humidity during the testing ranged from 26.7% to 45.6% RH.

TEST FLUID TEMPERATURE RANGE

FREQUENCY (MHZ)	835	1900
BODY / HEAD FLUID	BODY	BODY
MIN TEMPERATURE (°C)	22.2	21.7
MAX TEMPERATURE (°C)	22.4	22.5

SAR DRIFT

The SAR Drift was within acceptable limits during scans. The maximum SAR Drift, drift due to the handset electronics, was recorded as 6.91% (0.290dB) for all of the testing. The value 6.91% has been included in the measurement uncertainty budget.



3.5 MEASUREMENT UNCERTAINTY

Source of Uncertainty	Description	Tolerance / Uncertainty ± %	Probability distribution	Div	c i (1g)	Standard Uncertainty ± % (1g)	vi or veff
<i>Measurement System</i>							
<i>Probe calibration</i>	7.2.1	8.73	N	1	1	8.73	∞
<i>Isotropy</i>	7.2.1.2	3.18	R	1.73	1	1.84	∞
<i>Boundary effect</i>	7.2.1.5	0.49	R	1.73	1	0.28	∞
<i>Linearity</i>	7.2.1.3	1.00	R	1.73	1	0.58	∞
<i>Detection limits</i>	7.2.1.4	0.00	R	1.73	1	0.00	∞
<i>Readout electronics</i>	7.2.1.6	0.30	N	1	1	0.30	∞
<i>Response time</i>	7.2.1.7	0.00	R	1.73	1	0.00	∞
<i>Integration time (equiv.)</i>	7.2.1.8	1.38	R	1.73	1	0.80	∞
<i>RF ambient conditions</i>	7.2.3.6	3.00	R	1.73	1	1.73	∞
<i>Probe positioner mech. restrictions</i>	7.2.2.1	0.60	R	1.73	1	0.35	∞
<i>Probe positioning with respect to phantom shell</i>	7.2.2.3	2.00	R	1.73	1	1.15	∞
<i>Post-processing</i>	7.2.4	7.00	R	1.73	1	4.04	∞
<i>Dipole related</i>							
<i>Test Sample Positioning</i>	7.2.2.4	0.5	N	1	1	0.50	M-1
<i>Device Holder Uncertainty</i>	7.2.2.4.2	0.5	N	1	1	0.50	M-1
<i>Input Power and SAR Drift</i>	7.2.1.9	6.91	R	1.73	1	3.99	∞
<i>Phantom and set-up</i>							
<i>Phantom uncertainty (shape and thickness tolerances)</i>	7.2.2.2	2.01	R	1.73	1	1.16	∞
<i>Algorithm for correcting SAR for deviations in permittivity and conductivity</i>	7.2.3.3		N	1.00	1	0.00	∞
<i>Liquid conductivity (target)</i>	7.2.3.3	5.00	R	1.73	0.64	1.85	∞
<i>Liquid conductivity (meas.)</i>	7.2.3.3	5.00	N	1	0.64	3.20	∞
<i>Liquid permittivity (target)</i>	7.2.3.4	5.00	R	1.73	0.6	1.73	∞
<i>Liquid permittivity (meas.)</i>	7.2.3.4	3.00	N	1	0.6	1.80	∞
<i>Combined standard uncertainty</i>			RSS			11.80	
<i>Expanded uncertainty (95% confidence interval)</i>			K=2			23.59	



SECTION 4
PHOTOGRAPHS

4.1 TEST POSITIONAL PHOTOGRAPHS

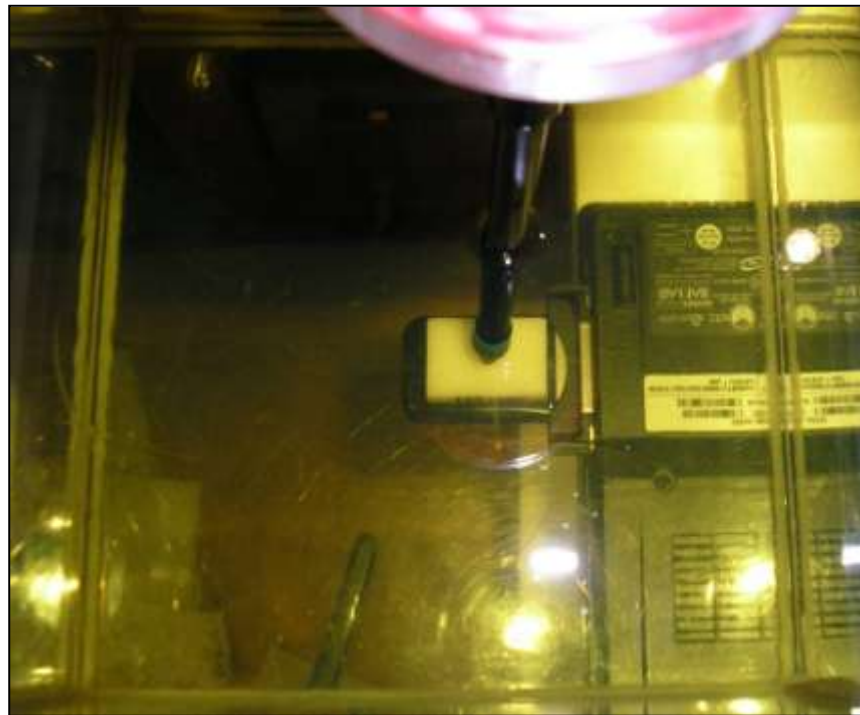

Figure 30: Top Positional Photograph of the Option NVGE0421 Express Card and adapter in 10mm separation distance configuration from the bottom of the flat phantom (Host laptop used: HP Compaq nc 6320 – in touch position)

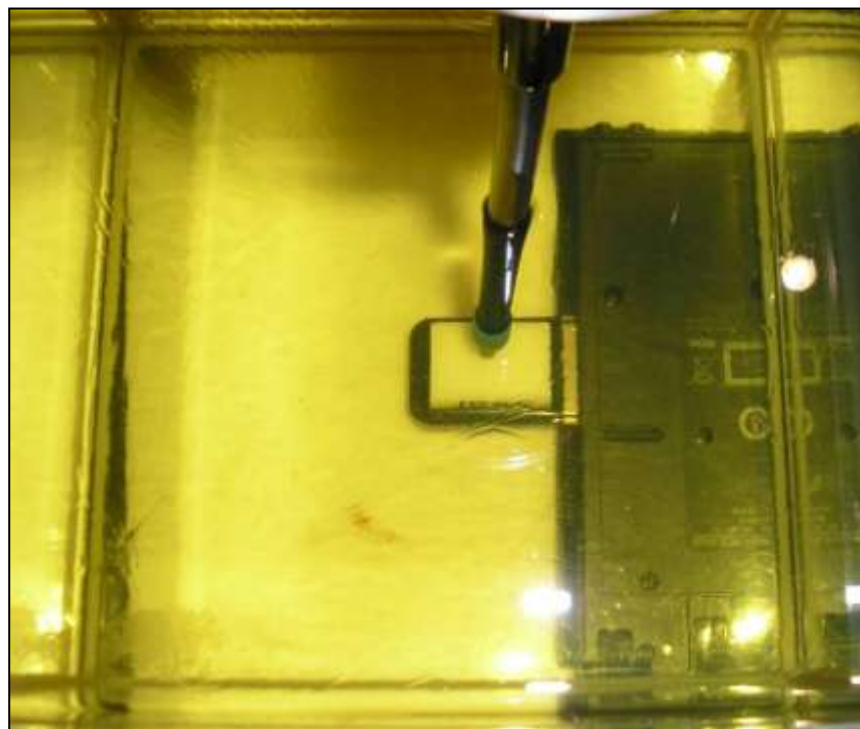

Figure 31: Top Positional Photograph of the Option NV GE0421 Express Card in 10mm separation distance configuration from the bottom of the flat phantom (Host laptop used: Sony Vaio VGN-TZ31MN/N – in touch position)

4.1 TEST POSITIONAL PHOTOGRAPHS - Continued



Figure 32: Front Positional Photograph of the Option NV GE0421 Express Card and adapter in 10mm Separation configuration from the bottom of the flat phantom (Host laptop used: HP Compaq nc 6320 – in touch position)

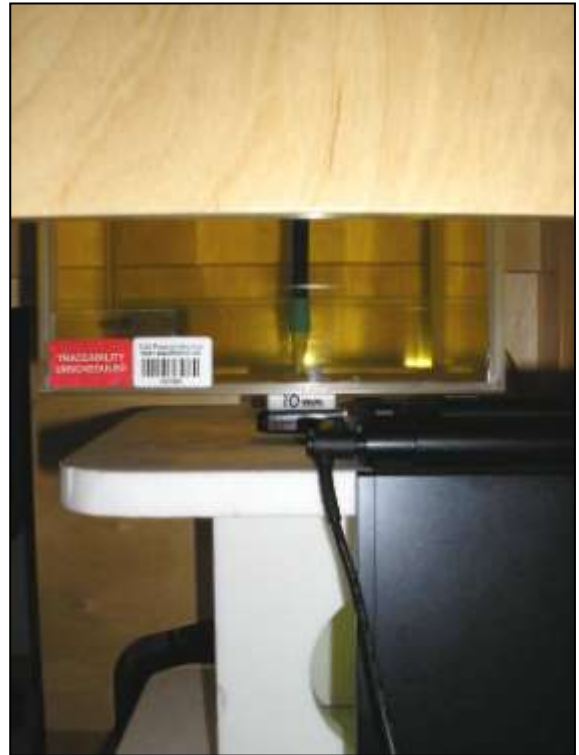

Figure 33: Front Positional Photograph of the Option NV GE0421 Express Card in 10mm Separation distance configuration from the bottom of the flat phantom (Host laptop used: Sony Vaio VGN-TZ31MN/N – in touch position)



4.2 PHOTOGRAPHS OF EQUIPMENT UNDER TEST (EUT)



Figure 34: GE0421 Express Card



Figure 35: Adapter

4.2 PHOTOGRAPHS OF EQUIPMENT UNDER TEST (EUT) - Continued



Figure 36: Front View of GE0421 Express Card and adapter connected to Host Laptop: HP Compaq nc 6320



Figure 37: Front View of GE0421 Express Card connected to Host Laptop: Sony Vaio VGN-TZ31MN/N

4.2 PHOTOGRAPHS OF EQUIPMENT UNDER TEST (EUT) - Continued



Figure 38: Side view of GE0421 Express Card and adapter connected to Host Laptop: HP Compaq nc 6320



Figure 39: Side view of GE0421 Express Card connected to Host Laptop: Sony Vaio VGN-TZ31MN/N



SECTION 5

ACCREDITATION, DISCLAIMERS AND COPYRIGHT



5.1 ACCREDITATION, DISCLAIMERS AND COPYRIGHT

This report relates only to the actual item/items tested.

This report must not be reproduced, except in its entirety, without the written permission of
TÜV Product Service Limited

© 2008 TÜV Product Service Limited



ANNEX A

PROBE CALIBRATION INFORMATION



IMMERSIBLE SAR PROBE

CALIBRATION REPORT

Part Number: IXP – 050

S/N 0187

September 2007

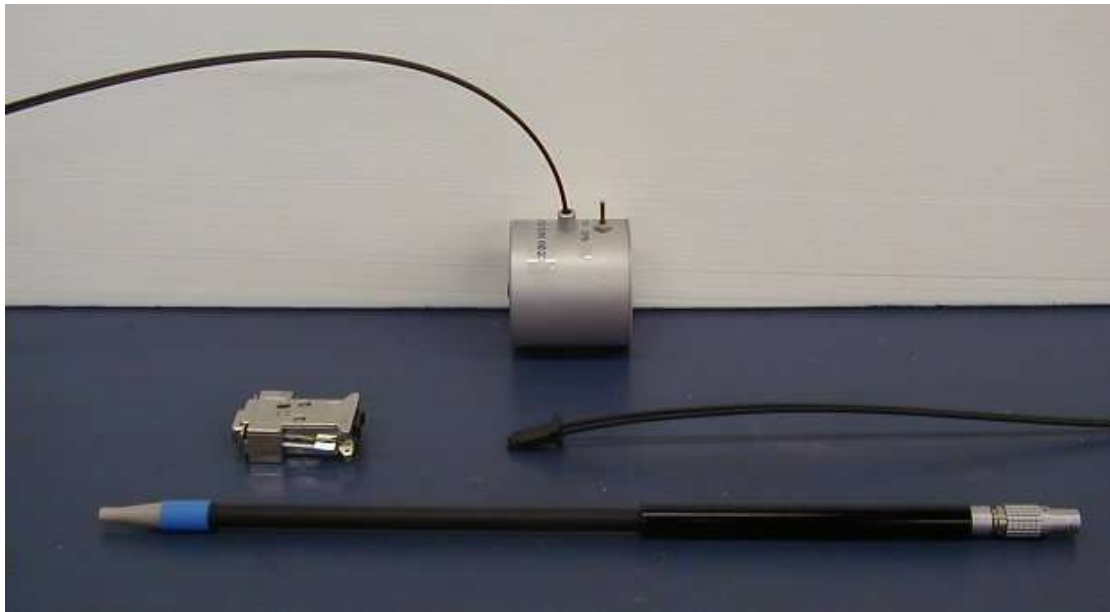

Indexsar Limited
Oakfield House
Cudworth Lane
Newdigate
Surrey RH5 5BG
Tel: +44 (0) 1306 632 870
Fax: +44 (0) 1306 631 834
e-mail: enquiries@indexsar.com



Product Service



**Indexsar
Limited**
Oakfield House
Cudworth Lane
Newdigate
Surrey RH5 5BG
Tel: +44 (0) 1306 632 870
Fax: +44 (0) 1306 631 834
e-mail: enquiries@indexsar.com

**Calibration Certificate 0709/0187
Dosimetric E-field Probe**

Type:	IXP-050
-------	---------

Manufacturer:	IndexSAR, UK
---------------	--------------

Serial Number:	0187
----------------	------

Place of Calibration:	IndexSAR, UK
-----------------------	--------------

IndexSAR Limited hereby declares that the IXP-050 Probe named above has been calibrated for conformity to the IEEE 1528 and CENELEC EN 50361:2001 standards on the date shown below.

Date of Initial Calibration:	24th September 2007
------------------------------	---------------------

The probe named above will require a calibration check on the date shown below.

Next Calibration Date:	September 2008
------------------------	----------------

The calibration was carried out using the methods described in the calibration document.

Where applicable, the standards used in the calibration process are traceable to the UK's National Physical Laboratory.

Calibrated By:	
----------------	--

Approved By:	
--------------	--

Please keep this certificate with the calibration document. When the probe is sent for a calibration check, please include the calibration document.

INTRODUCTION

This Report presents measured calibration data for a particular Indexsar SAR probe (S/N 0187) and describes the procedures used for characterisation and calibration.

Indexsar probes are characterised using procedures that, where applicable, follow the recommendations of CENELEC [1] and IEEE [2] standards. The procedures incorporate techniques for probe linearisation, isotropy assessment and determination of liquid factors (conversion factors). Calibrations are determined by comparing probe readings with analytical computations in canonical test geometries (waveguides) using normalised power inputs.

Each step of the calibration procedure and the equipment used is described in the sections below.

CALIBRATION PROCEDURE

1. Objectives

The calibration process comprises four stages

- 1) Determination of the channel sensitivity factors which optimise the probe's overall rotational isotropy in 900MHz brain fluid
- 2) Determination of the channel sensitivity factors and angular offset of the X channel which together optimise the probe's spherical isotropy in 900MHz brain fluid
- 3) Numerical combination of the two sets of channel sensitivity factors to give both acceptable rotational isotropy and acceptable spherical isotropy values
- 4) At each frequency of interest, application of these channel sensitivity factors to model the exponential decay of SAR in a waveguide fluid cell, and hence derive the liquid conversion factors at that frequency

2. Probe output

The probe channel output signals are linearised in the manner set out in Refs [1] and [2]. The following equation is utilized for each channel:

$$U_{lin} = U_{o/p} + U_{o/p}^2 / DCP \quad (1)$$

where U_{lin} is the linearised signal, $U_{o/p}$ is the raw output signal in voltage units and DCP is the diode compression potential in similar voltage units.

DCP is determined from fitting equation (1) to measurements of U_{lin} versus source feed power over the full dynamic range of the probe. The DCP is a characteristic of the Schottky diodes used as the sensors. For the IXP-050 probes with CW signals the DCP values are typically 0.10V (or 20 in the voltage units used by Indexsar software, which are V*200).

In turn, measurements of E-field are determined using the following equation (where output voltages are also in units of V*200):

$$E_{liq}^2 \text{ (V/m)} = U_{linx} * \text{Air Factor}_x * \text{Liq Factor}_x + U_{liny} * \text{Air Factor}_y * \text{Liq Factor}_y + U_{linz} * \text{Air Factor}_z * \text{Liq Factor}_z \quad (3)$$

Here, "Air Factor" represents each channel's sensitivity, while "Liq Factor" represents the enhancement in signal level when the probe is immersed in tissue-simulant liquids at each frequency of interest.

3. Selecting channel sensitivity factors to optimise isotropic response

After manufacture, the first stage of the calibration process is to balance the three channels' Air Factor values, thereby optimising the probe's overall axial response ("rotational isotropy").

To do this, a 900MHz waveguide containing head-fluid simulant is selected. Like all waveguides used during probe calibration, this particular waveguide contains two distinct sections: an air-filled launcher section, and a liquid cell section, separated by a dielectric matching window designed to minimise reflections at the air-liquid interface.

The waveguide stands in an upright position and the liquid cell section is filled with 900MHz brain fluid to within 10 mm of the open end. The depth of liquid ensures there is negligible radiation from the waveguide open top and that the probe calibration is not influenced by reflections from nearby objects.

During the measurement, a TE_{01} mode is launched into the waveguide by means of an N-type-to-waveguide adapter. The probe is then lowered vertically into the liquid until the tip is exactly 10mm above the centre of the dielectric window. This particular separation ensures that the probe is operating in a part of the waveguide where boundary corrections are not necessary.

Care must also be taken that the probe tip is centred while rotating.

The exact power applied to the input of the waveguide during this stage of the probe calibration is immaterial since only relative values are of interest while the probe rotates. However, the power must be sufficiently above the noise floor and free from drift.

The dedicated Indexsar calibration software rotates the probe in 10 degree steps about its axis, and at each position, an Indexsar 'Fast' amplifier samples the probe channels 500 times per second for 0.4 s. The raw $U_{o/p}$ data from each sample are packed into 10 bytes and transmitted back to the PC controller via an optical cable. U_{linx} , U_{liny} and U_{linz} are derived from the raw $U_{o/p}$ values and written to an Excel template.

Once data have been collected from a full probe rotation, the Air Factors are adjusted using a special Excel Solver routine to equalise the output from each channel and hence minimise the rotational isotropy. This automated approach to optimisation removes the effect of human bias.

Figure 5 represents the output from each diode sensor as a function of probe rotation angle.

4. Measurement of Spherical Isotropy

The setup for measuring the probe's spherical isotropy is shown in Figure 2.

A box phantom containing 900MHz head fluid is irradiated by a vertically-polarised, tuned dipole, mounted to the side of the phantom on the robot's seventh axis. During calibration, the spherical response is generated by rotating the probe about its axis in 20 degree steps and changing the dipole polarisation in 10 degree steps.

By using the VPM technique discussed below, an allowance can also be made for the effect of E-field gradient across the probe's spatial extent. This permits values for the probe's effective tip radius and X-channel angular offset to be modelled until the overall spherical isotropy figure is optimised.

The dipole is connected to a signal generator and amplifier via a directional coupler and power meter. As with the determination of rotational isotropy, the absolute power level is not important as long as it is stable.

The probe is positioned within the fluid so that its sensors are at the same vertical height as the centre of the source dipole. The line joining probe to dipole should be perpendicular to

the phantom wall, while the horizontal separation between the two should be small enough for VPM corrections to be applicable, without encroaching near the boundary layer of the phantom wall. VPM corrections require a knowledge of the fluid skin depth. This is measured during the calibration by recording the E-field strength while systematically moving the probe away from the dipole in 2mm steps over a 20mm range.

The directionality of the orthogonally-arranged sensors can be checked by analysing the data using dedicated Indexsar software, which displays the data in 3D format, a representative image of which is shown in Figure 3. The left-hand side of this diagram shows the individual channel outputs after linearisation (see above). The program uses these data to balance the channel outputs and then applies an optimisation process, which makes fine adjustments to the channel factors for optimum isotropic response.

5. Determination of Conversion (“Liquid”) Factors at each frequency of interest

A lookup table of conversion factors for a probe allows a SAR value to be derived at the measured frequencies, and for either brain or body fluid-simulant.

The method by which the conversion factors are assessed is based on the comparison between measured and analytical rates of decay of SAR with height above a dielectric window. This way, not only can the conversion factors for that frequency/fluid combination be determined, but an allowance can also be made for the scale and range of boundary layer effects.

The theoretical relationship between the SAR at the cross-sectional centre of the lossy waveguide as a function of the longitudinal distance (z) from the dielectric separator is given by Equation 4:

$$SAR(z) = \frac{4 P_f - P_b}{\rho ab\delta} e^{-2z/\delta} \quad (4)$$

Here, the density ρ is conventionally assumed to be 1000 kg/m^3 , ab is the cross-sectional area of the waveguide, and P_f and P_b are the forward and reflected power inside the lossless section of the waveguide, respectively. The penetration depth δ (which is the reciprocal of the waveguide-mode attenuation coefficient) is a property of the lossy liquid and is given by Equation (5).

$$\delta = \left[\text{Re} \sqrt{\pi / a^2 + j\omega\mu_o \sigma + j\omega\epsilon_o\epsilon_r} \right]^{-1} \quad (5)$$

where σ is the conductivity of the tissue-simulant liquid in S/m, ϵ_r is its relative permittivity, and ω is the radial frequency (rad/s). Values for σ and ϵ_r are obtained prior to each waveguide test using an Indexsar DiLine measurement kit, which uses the TEM method as recommended in [2]. σ and ϵ_r are both temperature- and fluid-dependent, so are best measured using a sample of the tissue-simulant fluid immediately prior to the actual calibration.

Wherever possible, all DiLine and calibration measurements should be made in the open laboratory at $22 \pm 2.0^\circ\text{C}$; if this is not possible, the values of σ and ϵ_r should reflect the actual temperature. Values employed for calibration are listed in the tables below.

By ensuring the liquid height in the waveguide is at least three penetration depths, reflections at the upper surface of the liquid are negligible. The power absorbed in the liquid is therefore determined solely from the waveguide forward and reflected power.

Different waveguides are used for 835/900MHz, 1800/1900MHz, 2450MHz and 5200/5800MHz measurements. Table A.1 of [1] can be used for designing calibration waveguides with a return loss greater than 20 dB at the most important frequencies used for personal wireless communications, and better than 15dB for frequencies greater than 5GHz. Values for the penetration depth for these specific fixtures and tissue-simulating mixtures are also listed in Table A.1.

According to [1], this calibration technique provides excellent accuracy, with standard uncertainty of less than 3.6% depending on the frequency and medium. The calibration itself is reduced to power measurements traceable to a standard calibration procedure. The practical limitation to the frequency band of 800 to 5800 MHz because of the waveguide size is not severe in the context of compliance testing.

During calibration, the probe is lowered carefully until it is just touching the cross-sectional centre of the dielectric window. 200 samples are then taken and written to an Excel template file before moving the probe vertically upwards. This cycle is repeated 150 times. The vertical separation between readings is determined from practical considerations of the expected SAR decay rate, and range from 0.2mm steps at low frequency, through 0.1mm at 2450MHz, down to 0.05mm at 5GHz.

Once the data collection is complete, a Solver routine is run which optimises the measured-theoretical fit by varying the conversion factor, and the boundary correction size and range.

For 450 MHz calibrations, a slightly different technique must be used — the equatorial response of the probe-under-test is compared with the equivalent response of a probe whose 450MHz characteristics have already been determined by NPL. The conversion factor of the probe-under-test can then be deduced.

VPM (Virtual Probe Miniaturisation)

SAR probes with 3 diode-sensors in an orthogonal arrangement are designed to display an isotropic response when exposed to a uniform field. However, the probes are ordinarily used for measurements in non-uniform fields and isotropy is not assured when the field gradients are significant compared to the dimensions of the tip containing the three orthogonally-arranged dipole sensors.

It becomes increasingly important to assess the effects of field gradients on SAR probe readings when higher frequencies are being used. For Indexsar IXP-050 probes, which are of 5mm tip diameter, field gradient effects are minor at GSM frequencies, but are major above 5GHz. Smaller probes are less affected by field gradients and so probes, which are significantly less than 5mm diameter, would be better for applications above 5GHz.

The IndexSAR report IXS0223 describes theoretical and experimental studies to evaluate the issues associated with the use of probes at arbitrary angles to surfaces and field directions. Based upon these studies, the procedures and uncertainty analyses referred to in P1528 are addressed for the full range of probe presentation angles.

In addition, generalized procedures for correcting for the finite size of immersible SAR probes are developed. Use of these procedures enables application of schemes for virtual probe miniaturization (VPM) – allowing probes of a specific size to be used where physically-smaller probes would otherwise be required.

Given the typical dimensions of 3-channel SAR probes presently available, use of the VPM technique extends the satisfactory measurement range to higher frequencies.

CALIBRATION FACTORS MEASURED FOR PROBE S/N 0187

The probe was calibrated at 450, 835, 900, 1800, 1900, 2100 and 2450 MHz in liquid samples representing brain and body liquid at these frequencies.

The calibration was for CW signals only, and the axis of the probe was parallel to the direction of propagation of the incident field i.e. end-on to the incident radiation. The axial isotropy of the probe was measured by rotating the probe about its axis in 10 degree steps through 360 degrees in this orientation.

The reference point for the calibration is in the centre of the probe's cross-section at a distance of 2.7 mm from the probe tip in the direction of the probe amplifier. A value of 2.7 mm should be used for the tip to sensor offset distance in the software. The distance of 2.7mm for assembled probes has been confirmed by taking X-ray images of the probe tips (see Figure 9).

It is important that the diode compression point and air factors used in the software are the same as those quoted in the results tables, as these are used to convert the diode output voltages to a SAR value.

MEASUREMENT UNCERTAINTIES

A complete measurement uncertainty analysis for the SARA2 measurement system has been published in Reference [3]. Table 10 from that document is re-created below, and lists the uncertainty factors associated just with the calibration of probes.

Source of uncertainty	Uncertainty value \pm %	Probability distribution	Divisor	c_i	Standard uncertainty $u_i \pm$ %	v_i or v_{eff}
Incident or forward power	5.743	N	1.00	1	5.743	∞
Reflected power	5.773	N	1.00	1	5.773	∞
Liquid conductivity	1.120	N	1.00	1	1.120	∞
Liquid permittivity	1.085	N	1.00	1	1.085	∞
Field homogeneity	0.002	R	1.73	1	0.001	∞
Probe positioning: +/- 0.05mm	0.55	R	1.73	1	0.318	
Influence on Probe pos: 11%/mm						
Field probe linearity	4.7	R	1.73	1	2.714	∞
Combined standard uncertainty		RSS			8.729	

At the 95% confidence level, therefore, the expanded uncertainty is 17.1%

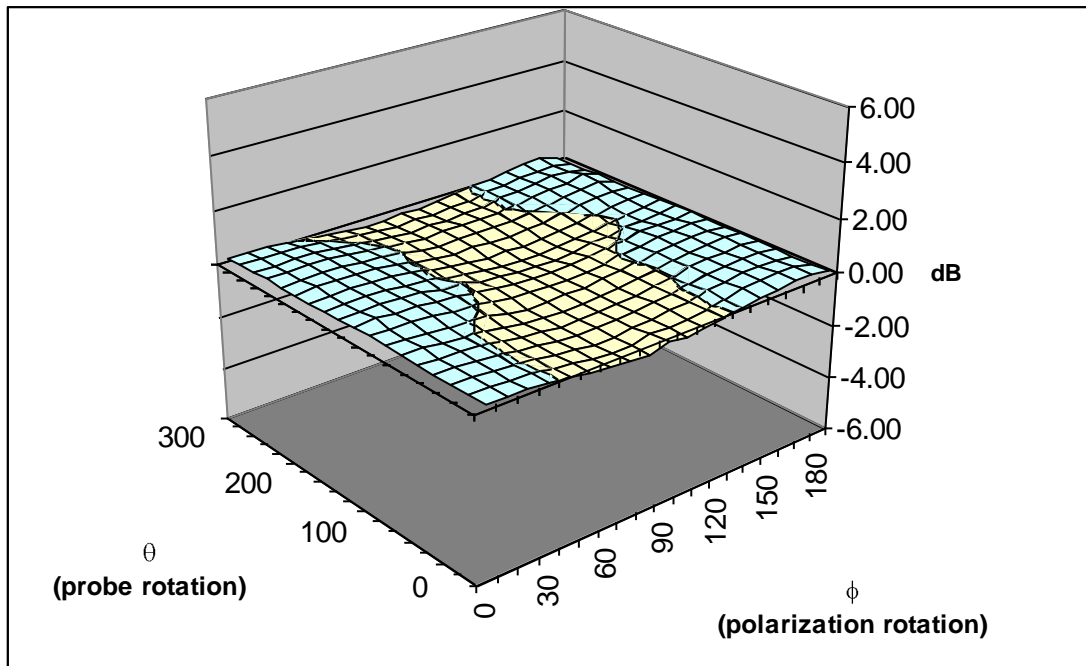

Surface Isotropy diagram of IXP-050 Probe S/N 0187 at 900MHz after VPM (rotational isotropy axial +/-0.06dB, spherical isotropy +/-0.38dB)

Probe tip radius 1.25
 X Ch. Angle to red dot 11

Frequency	Head		Body	
	Bdy. Corr. – f(0)	Bdy. Corr. – d(mm)	Bdy. Corr. – f(0)	Bdy. Corr. – d(mm)
450	-	-	-	-
835	0.81	1.5	1.12	1.3
900	0.91	1.4	1.09	1.3
1800	0.98	1.4	0.95	1.4
1900	0.95	1.4	0.86	1.6
2100	0.80	1.5	0.69	1.9
2450	0.83	1.6	0.73	1.8



SUMMARY OF CALIBRATION FACTORS FOR PROBE IXP-050 S/N 0187

Spherical isotropy measured at 900MHz	0.38	(+/-) dB
---------------------------------------	------	----------

	X	Y	Z	
Air Factors	346	439	415	(V*200)
CW DCPs	20	20	20	(V*200)

Freq (MHz)	Axial Isotropy (+/- dB)		SAR ConvF (liq/air)		Notes
	Head	Body	Head	Body	
	450	-	-	0.349	
835	-	-	0.318	0.318	1,2
900	0.06	-	0.319	0.332	1,2
1800	-	-	0.371	0.422	1,2
1900	-	-	0.376	0.440	1,2
2100	-	-	0.405	0.463	1,2
2450	-	-	0.432	0.501	1,2

Notes	
1)	Calibrations done at 22°C +/-2°C
2)	Waveguide calibration
3)	Transfer calibration

PROBE SPECIFICATIONS

Indexsar probe 0187, along with its calibration, is compared with CENELEC and IEEE standards recommendations (Refs [1] and [2]) in the Tables below. A listing of relevant specifications is contained in the tables below:

Dimensions	S/N 0187	CENELEC [1]	IEEE [2]
Overall length (mm)	350		
Tip length (mm)	10		
Body diameter (mm)	12		
Tip diameter (mm)	5.2	8	8
Distance from probe tip to dipole centers (mm)	2.7		

Dynamic range	S/N 0187	CENELEC [1]	IEEE [2]
Minimum (W/kg)	0.01	<0.02	0.01
Maximum (W/kg) N.B. only measured to > 100 W/kg on representative probes	>100	>100	100

Isotropy (measured at 900MHz)	S/N 0187	CENELEC [1]	IEEE [2]
Axial rotation with probe normal to source (+/- dB)	0.06 (See table above)	0.5	0.25
Spherical isotropy covering all orientations to source (+/- dB)	0.38	1.0	0.50

Construction	Each probe contains three orthogonal dipole sensors arranged on a triangular prism core, protected against static charges by built-in shielding, and covered at the tip by PEEK cylindrical enclosure material. No adhesives are used in the immersed section. Outer case materials are PEEK and heat-shrink sleeving.
Chemical resistance	Tested to be resistant to glycol and alcohol containing simulant liquids but probes should be removed, cleaned and dried when not in use.



REFERENCES

- [1] CENELEC, EN 50361, July 2001. Basic Standard for the measurement of specific absorption rate related to human exposure to electromagnetic fields from mobile phones.
- [2] IEEE 1528, Recommended practice for determining the spatial-peak specific absorption rate (SAR) in the human body due to wireless communications devices: Experimental techniques.
- [3] Indexsar Report IXS-0300, October 2007. Measurement uncertainties for the SARA2 system assessed against the recommendations of BS EN 50361: 2001

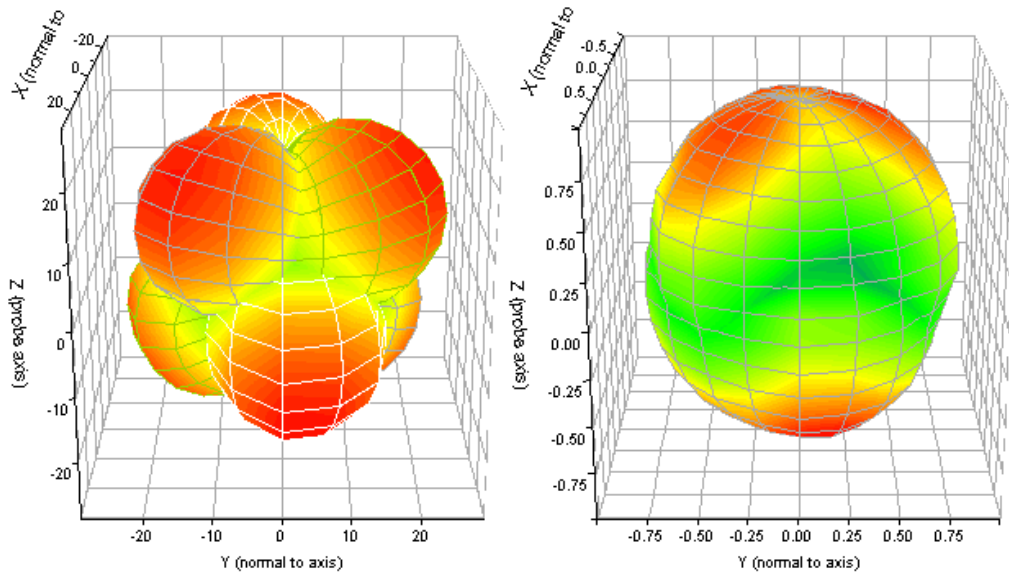

Figure 3. Graphical representation of a probe's response to fields applied from each direction. The diagram on the left shows the individual response characteristics of each of the three channels and the diagram on the right shows the resulting probe sensitivity in each direction. The colour range in the figure images the lowest values as blue and the maximum values as red. For probe S/N 0187, this range is (+/-) 0.38dB.

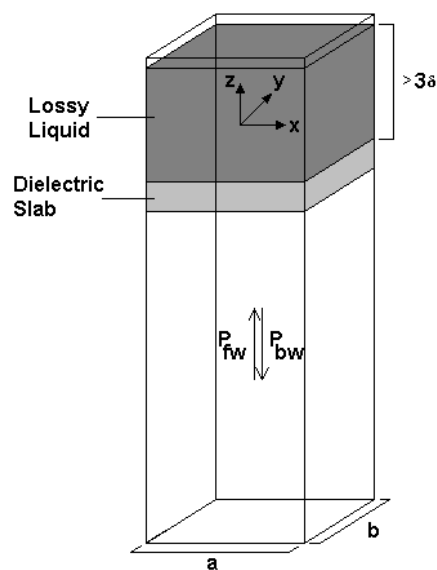

Figure 4. Geometry used for waveguide calibration (after Ref [2]. Section A.3.2.2)

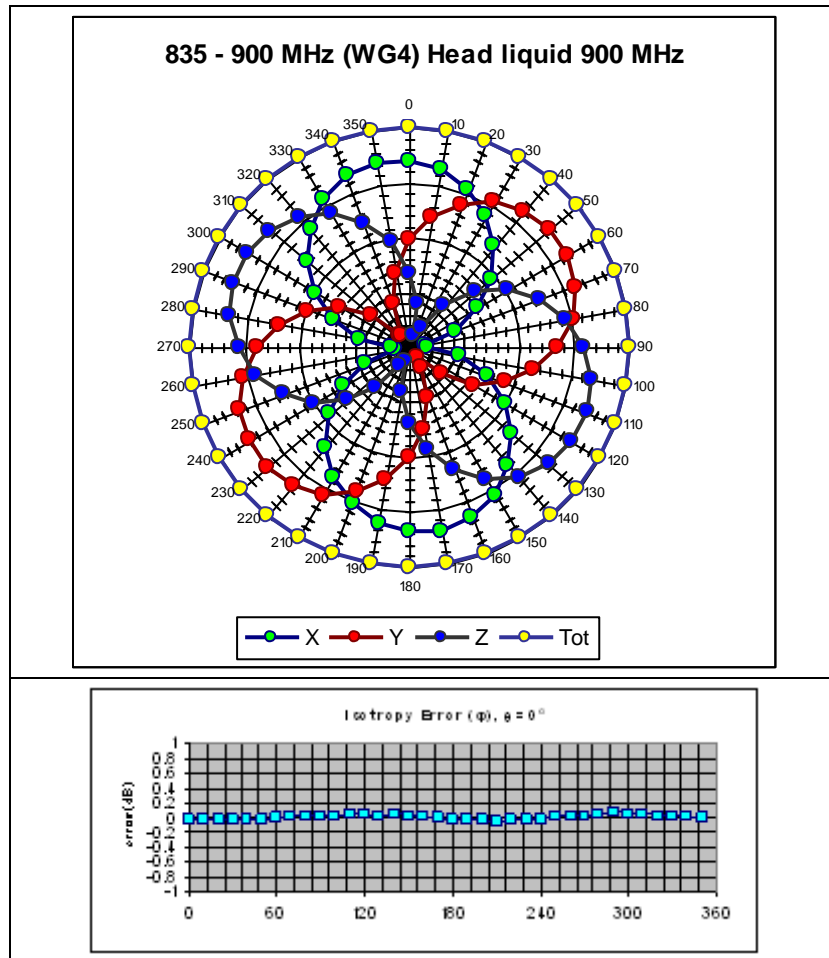

Figure 5. The rotational isotropy of probe S/N 0187 obtained by rotating the probe in a liquid-filled waveguide at 900 MHz.

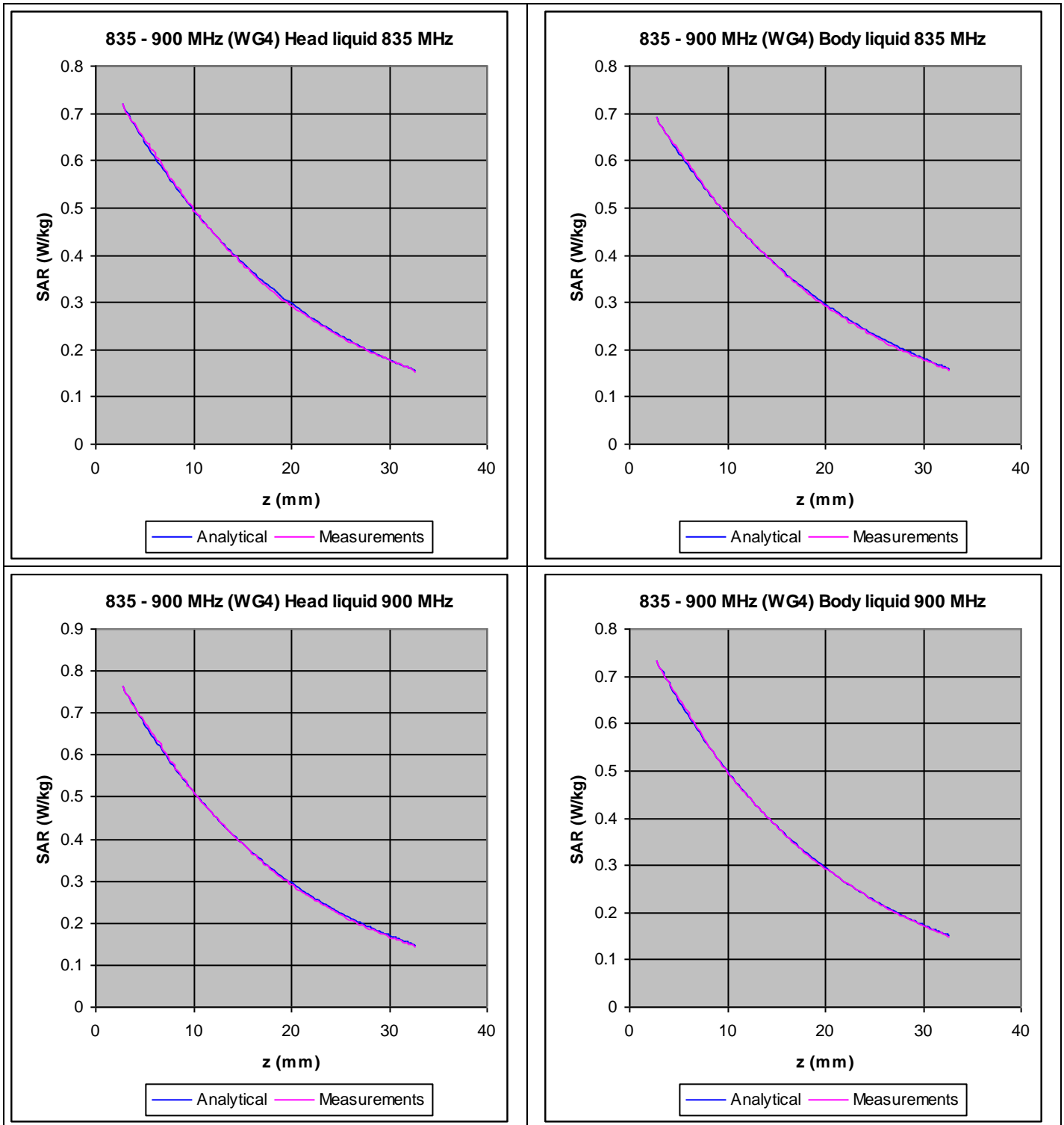
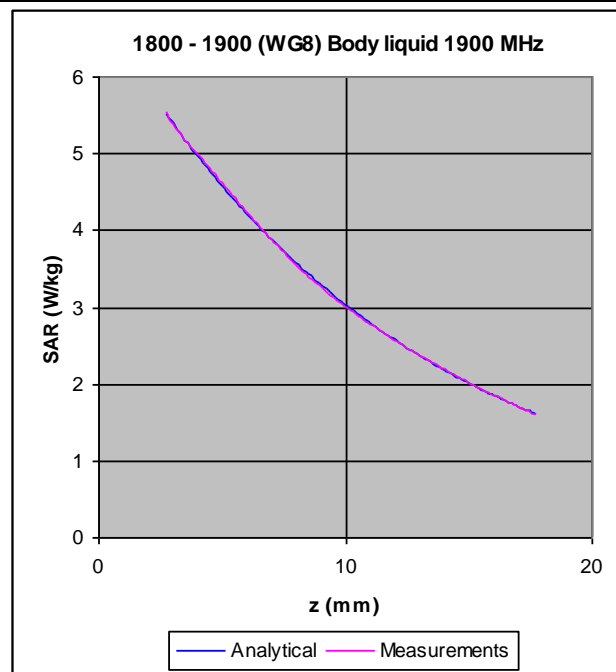
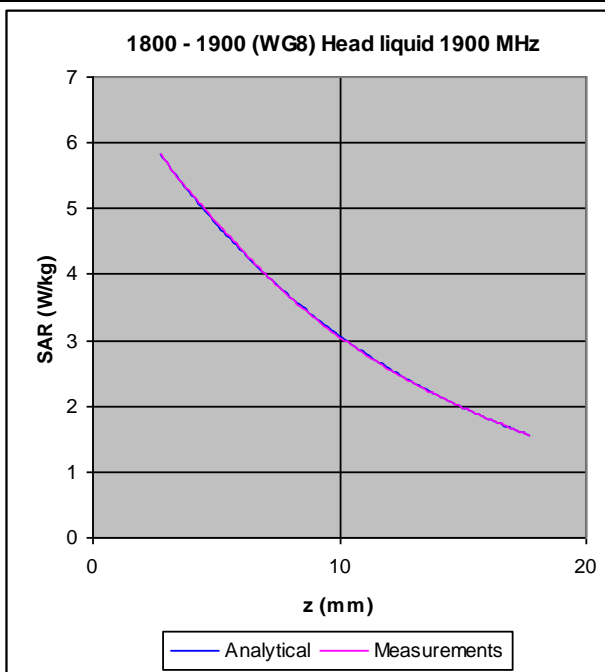
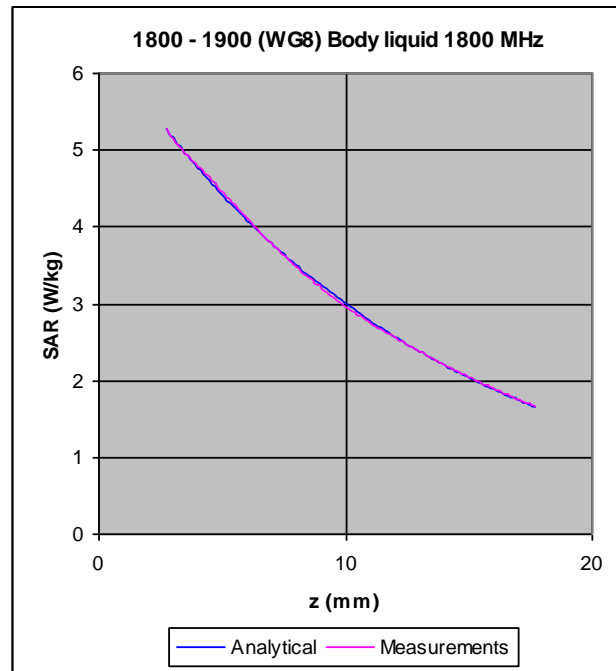
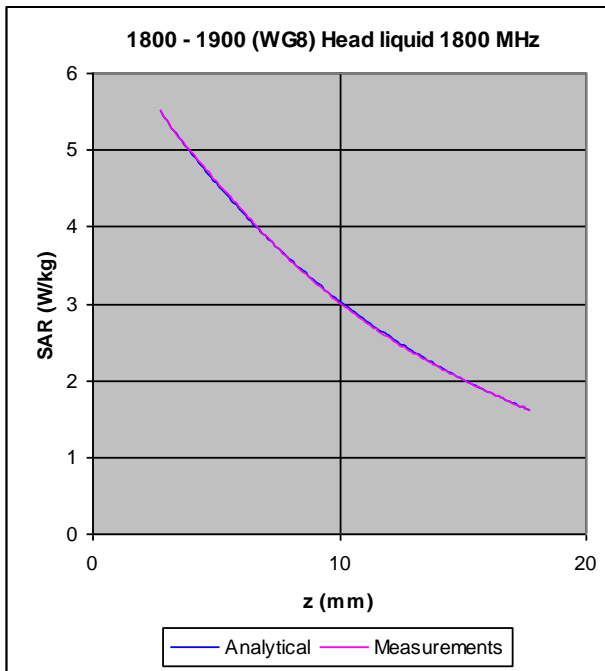

Figure 6. The measured SAR decay function along the centreline of the WG4 waveguide with conversion factors adjusted to fit to the theoretical function for the particular dimension, frequency, power and liquid properties employed.



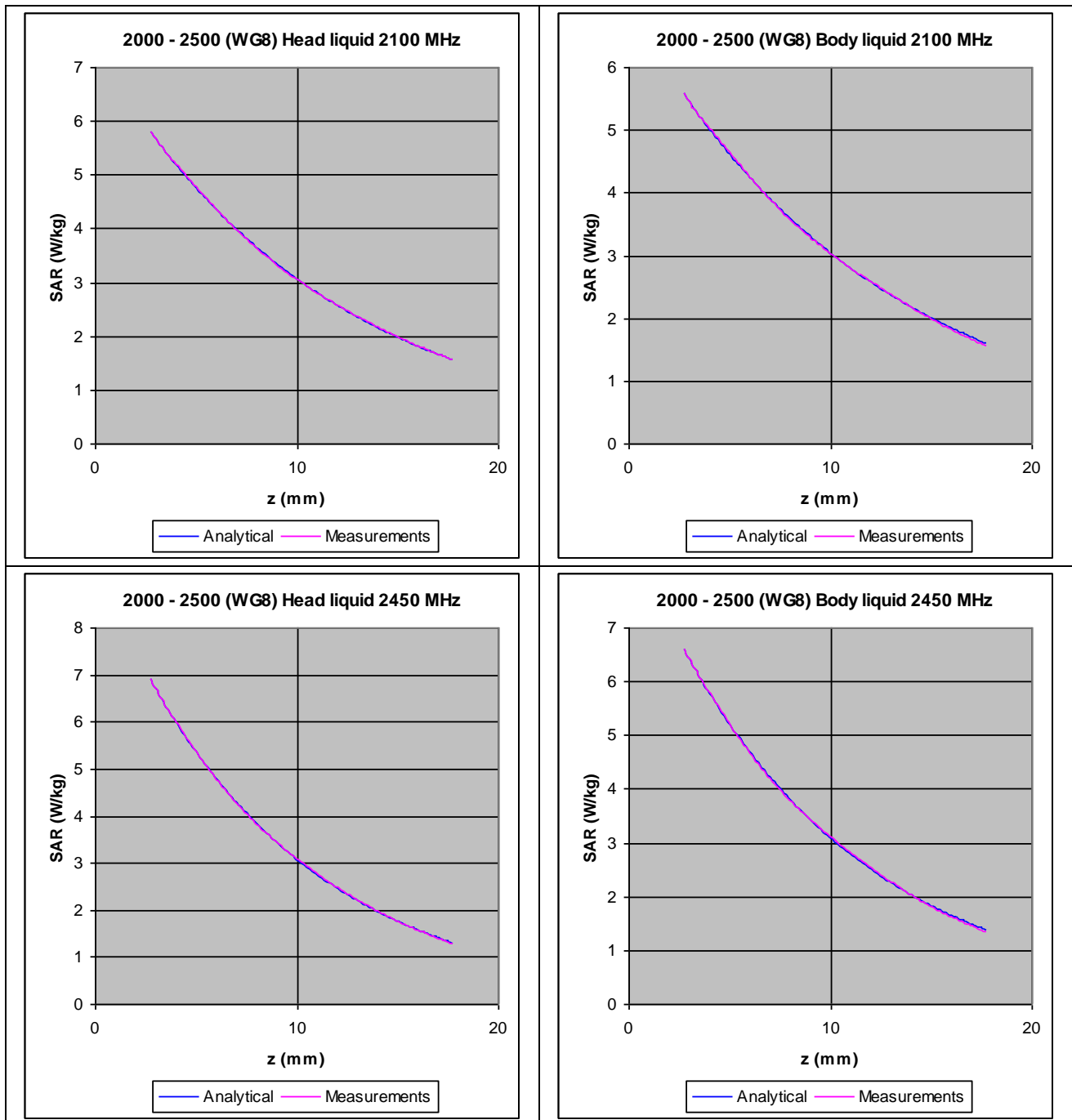

Figure 7. The measured SAR decay function along the centreline of the R22 waveguide with conversion factors adjusted to fit to the theoretical function for the particular dimension, frequency, power and liquid properties employed.

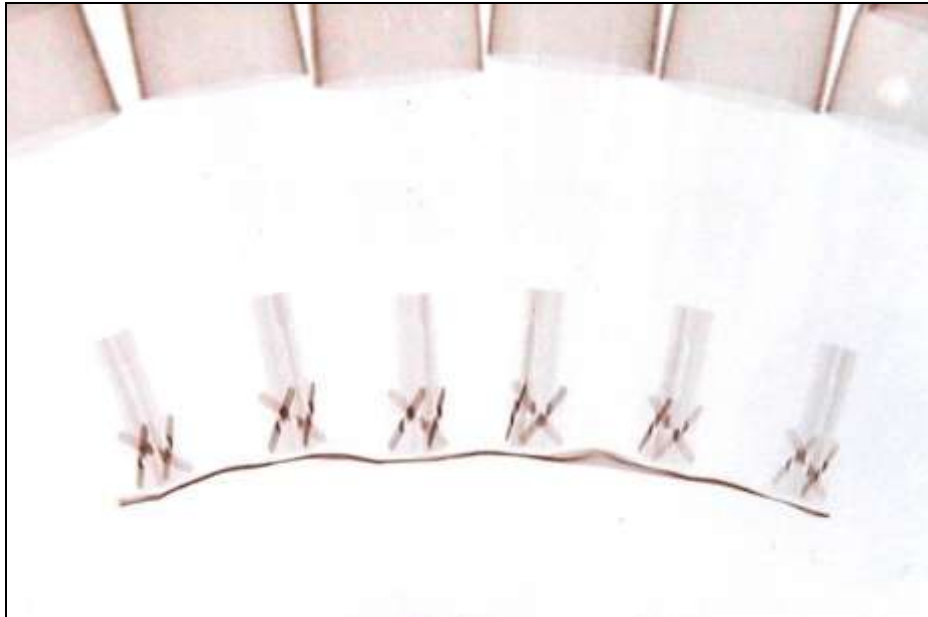

Figure 9: X-ray positive image of 5mm probes

Table indicating the dielectric parameters of the liquids used for calibrations at each frequency

Liquid used	Relative permittivity (measured)	Conductivity (S/m) (measured)
450 MHz BRAIN	44.56	0.84
450 MHz BODY	56.45	0.75
835 MHz BRAIN	42.38	0.91
835 MHz BODY	55.54	0.99
900 MHz BRAIN	41.61	0.97
900 MHz BODY	54.92	1.06
1800 MHz BRAIN	38.69	1.38
1800 MHz BODY	54.53	1.54
1900 MHz BRAIN	38.26	1.48
1900 MHz BODY	54.26	1.63
2100 MHz BRAIN	40.18	1.50
2100 MHz BODY	51.27	1.60
2450 MHz BRAIN	38.78	1.87
2450 MHz BODY	50.30	1.99