

Title: **PLI Evaluation Report (RFI)** **FCC ID: NCE5141U** Page 1 of 46
Drawing: Q514103FCCW.DWG Issued: 15 Apr 1999
By: Greg Noll Approved: Lee Pulver

This drawing consists of pages issued or re-issued on dates shown in the following list. Italic underlined words indicate content changes or additions on revised pages.

PAGE	ISSUED
1 - 46	15 Apr 1999

COMPANY CONFIDENTIAL

This report is the property of Pulver Laboratories Inc. The information contained in this report can only be divulged to persons authorized by Pulver Laboratories Inc.

Portions of this report contain information proprietary to Integrated Device Technology, Inc.; other portions of this report contain information proprietary to Pulver Laboratories and the RFI Controls Company. Except for agencies like the Federal Communications Commission, companies must sign Non-Use and Non-Disclosure Agreements before authorized to read this report.

All rights reserved. No part of this report may be reproduced or transmitted in any form or by any means without permission in writing from Pulver Laboratories Inc.

Copyright 1983 - 1999 Pulver Laboratories Inc.
PLI223F11W.FRMx1
Q514103W.DWG

Pulver Laboratories Inc.
320 North Santa Cruz Avenue Los Gatos, California 95030-7243
Telephone: 408.399.7000 Facsimile: 408.399.7001 www.pulverlabs.com

Title: **PLI Evaluation Report (RFI)** **FCC ID: NCE5141U**
Drawing: Q514103FCCW.DWG
By: Greg Noll

Page 2 of 46
Issued: 15 Apr 1999
Approved: Lee Pulver

TABLE OF CONTENTS

Page	Section	Description
1	0.0	Drawing; Client; Product; Standards
5	1.0	Engineering Considerations
	1.1	General Engineering Considerations
	1.1.1	1 October 1998 FCC Conformance Statement
6	1.2	Specific Engineering Considerations
	1.3	Product Description and Intended Use
7	1.4	Abbreviated List of Photographs
8	1.5	Equipment Used During Measurements
16	2.0	Mandatory Labeling, Manual Information, and Shipping Documents
	2.1	FCC Label
17		Illustration 1.0: FCC Label
18	2.2	Operators' Manual Information
	2.3	FCC User Information
20		Photographs
32		Clock Oscillators
33		EUT Orientation
34	3.0	Radiated Electromagnetic Interference - Test Configuration
37	4.0	Radiated EMI - Results
41	5.0	Conducted EMI -Test Configuration
	6.0	Conducted EMI - Results
45		FCC Conducted Graphs
46		Last Page of Report
		Certificate of Conformance

Title: **PLI Evaluation Report (RFI)** **FCC ID: NCE5141U**
Drawing: Q514103FCCW.DWG
By: Greg Noll

Page 3 of 46
Issued: 15 Apr 1999
Approved: Lee Pulver

Pulver Laboratories File Number: 5141
Pulver Laboratories Project Number: C1029

Product Names: EUT) 155 Mbps ATM Adapter Card
(EUT = Equipment Under Test)

Model Numbers: 7M925

Serial Numbers: 00E0CF003A20

Applicant: Integrated Device Technology, Inc.
2975 Stender Way
Santa Clara, California 95054
Telephone: 800.345.7015
Facsimile: 408.492.8674
Website: www.idt.com

Location Certified: Integrated Device Technology, Inc.
2975 Stender Way
Santa Clara, California 95054
Telephone: 800.345.7015
Facsimile: 408.492.8674
Website: www.idt.com

Manufacturing Location: Integrated Device Technology, Inc.
2975 Stender Way
Santa Clara, California 95054
Telephone: 800.345.7015
Facsimile: 408.492.8674
Website: www.idt.com

Pulver Laboratories Control Number: 5141X

Equipment Category

Information Technology Equipment including Electrical Business Equipment

Title: **PLI Evaluation Report (RFI)** **FCC ID: NCE5141U**
Drawing: Q514103FCCW.DWG
By: Greg Noll

Page 4 of 46
Issued: 15 Apr 1999
Approved: Lee Pulver

Evaluated to the Following Standards

Federal Communications Commission (FCC, USA)

Category Classification
Class B - Residential
FCC ID: NCE5141U

- American National Standards Institute C63.4-1992 entitled Methods of Measurement of Radio-Noise Emissions from Low-Voltage Electrical and Electronic Equipment in the Range of 9 kHz to 40 GHz.
- Federal Communications Commission Rules and Regulations located in the Code of Federal Regulations, Title 47, Part 2 entitled Frequency Allocations and Radio Treaty Matters; General Rules and Regulations; and Part 15 entitled Radio Frequency Devices, 1 October 1998 Edition.

Trademarks

All trademarks and registered trademarks shown or mentioned in this Pulver Laboratories Product Evaluation Report belong to their respective holders.

1.0 Engineering Considerations

1.1 General Engineering Considerations

1.1.1 This report deals with conformance to the:

- Code of Federal Regulations, 47 CFR, Part 2 and Part 15, revised 1 October 1998;
- American National Standards Institute standard number C63.4-1992 entitled Methods of Measurement of Radio-Noise Emissions from Low-Voltage Electrical and Electronic Equipment in the Range of 9 kHz to 40 GHz.

1.1.2 This report also deals with conformance to Radio Frequency Interference Suppression of High Frequency Equipment for Industrial, Scientific, and Medical (ISM) and similar purposes for Canada and the countries listed in the Pulver Laboratories Certificate of Conformance associated with this report.

1.1.3 To assist the Federal Communications Commission in the continuing education of applicants and grantees, Pulver Laboratories has advised Integrated Device Technology, Inc. to purchase a copy of the Rules and Regulations located in the Code of Federal Regulations, Title 47, Part 2 entitled Frequency Allocations and Radio Treaty Matters; General Rules and Regulations; and Part 15 entitled Radio Frequency Devices, 1 October 1998 Edition.

1.1.4 The manufacturer has a contractual obligation to Pulver Laboratories to incorporate into production all modifications photographed and outlined in this report with associated documentation.

1.1.5 The Pulver Laboratories Certificate of Conformance issued with this report allows the manufacturer to ship and sell product using the Pulver Laboratories Product Certification Label. This label can only be used if the manufacturer allows Pulver Laboratories to conduct a Follow Up Service at the manufacturing facilities and conduct an Electromagnetic Interference test of the finished product every six months.

1.2 Specific Engineering Considerations

1.2.1 Interconnecting low voltage computer cables lengths:

Cable Description	Length (feet)	Length (meters)
Keyboard	4.42	1.35
Monitor	4.42	1.35
Mouse	5.00	1.52
Printer	6.00	1.83
UTP Cat 5 Cable (8-wire)	32.00	9.75

1.2.2 I / O Cables coiled and wrapped to maximum lengths of 30 to 40 cm, at least 40 cm from ground plane as recommended by ANSI 63.4-1992.

1.2.3 Test Configuration with Monitor attached to input power mains radiated more electromagnetic interference than with the monitor connected to the CPU. Therefore, the data in this report reflects the monitor connected directly to the AC mains.

1.2.4 There is one possible EUT (155 Mbps ATM Adapter Card, Model 7M925) input power configuration:

1.2.4.1 The EUT derives power from the Host Computer.

1.2.5 There is one possible EUT test configuration:

1.2.5.1 **Test Configuration #1:** The Model 7M925 was plugged into the Host Computer System and connected to a Sender/Receiver Computer System allowing data transfer between the two computers via the card and data cable.

1.3 Product Description and Intended Use

1.3.1 The Integrated Device Technology, Inc. 155 Mbps ATM Adapter Card, 7M925 is an ATM adapter with a PCI interface which allows data transfer between Professional or Business Computers. Connection between computers utilizing UTP CAT 5 Cable (8-wire).

1.4 **List of Photographs Contained in this Report**

- FIGURE 1:** PLI Photograph Number 991607 illustrates the rear view of the Host Computer containing the Equipment Under Test, with all peripherals attached in Test Configuration #1. Shown in the foreground is the Sender/Receiver Computer System. The "open field" radiated and the "screen room" conducted Radio Frequency Interference / Electromagnetic Interference test programs utilized this equipment and cable configuration.
- FIGURE 2:** PLI Photograph Number 991608 illustrates the rear view of the Host Computer System containing the Equipment Under Test with all peripherals attached in Test Configuration #1. The "open field" radiated and the "screen room" conducted Radio Frequency Interference / Electromagnetic Interference test programs utilized this equipment and cable configuration.
- FIGURE 3:** PLI Photograph Number 991609 illustrates the left oblique view of the Host Computer containing the Equipment Under Test with all peripherals attached in the "screen room" conducted Electromagnetic Interference Test Configuration #1.
- FIGURE 4:** PLI Photograph Number 991610 illustrates the top view of the Host Computer with the top cover removed showing the placement of the installed Equipment Under Test inside the computer, and reflecting the placement of the internal ribbon cables attaching the Equipment Under Test to the motherboard and associated internal system components.
- FIGURE 5:** PLI Photograph Number 991406 illustrates the component side of the 155 Mbps ATM Adapter Card, Model 7M925, Serial number 00E0CF003A20 rev B1.
- FIGURE 6:** PLI Photograph Number 991407 illustrates the circuit side of the 155 Mbps ATM Adapter Card, Model 7M925, Serial number 00E0CF003A20 rev B1.

Title: **PLI Evaluation Report (RFI)** **FCC ID: NCE5141U**
Drawing: Q514103FCCW.DWG
By: Greg Noll

Page 8 of 46
Issued: 15 Apr 1999
Approved: Lee Pulver

- 1.5 Equipment used during measurements calibrated according to internationally acceptable laboratory procedures. Calibration data along with Certificates of conformance and traceability are on file at the testing facility. Each calibrated equipment item is individually labeled with date calibrated; due date for next calibration; initials of person who calibrated the equipment; and the name of the organization that performed the calibration service.

Title: **PLI Evaluation Report (RFI)**
Drawing: Q514103FCCW.DWG
By: Greg Noll

FCC ID: NCE5141U

Page 9 of 46
Issued: 15 Apr 1999
Approved: Lee Pulver

Equipment Type	Manufacturer	Model Number	Frequency Range
Spectrum Analyzer	Hewlett Packard	8568A	100 Hz - 1.5 GHz
Quasi-peak	Hewlett Packard	85650A	10 kHz - 1.00 GHz
Biconical Antenna	EMCO	3109	30 - 200 MHz
Log Periodic Antenna	EMCO	3146	200 - 1000 MHz
Magnetic Loop Antenna	Electro-Metrics	ALR-25M	10 kHz - 30 MHz
Oscilloscope Camera	Tektronix	C-5C	
Amplifier	Hewlett Packard	8447D Option 010	0.1 - 1300 MHz
Attenuator	Narda	757C (35797)	3 dB (DC - 12.4 GHz)
Attenuator	Narda	757C (36808)	6 dB (DC - 12.4 GHz)
Attenuator	Narda	757C (40604)	10 dB (DC - 12.4 GHz)
Attenuator	Narda	757C (40998)	20 dB (DC - 12.4 GHz)
Close Field Antenna	Electro-Metrics	EFP-25	
Oscilloscope	Tektronix	2445	up to 150 MHz

Title: **PLI Evaluation Report (RFI)**
Drawing: Q514103FCCW.DWG
By: Greg Noll

FCC ID: NCE5141U

Page 10 of 46
Issued: 15 Apr 1999
Approved: Lee Pulver

Equipment Type	Manufacturer	Model Number	Frequency Range
Capacitor/ Inductor Z Meter	Sencore	1 picofarad to 200,000 microfarads 1 micro Henry to 10 Henries	
L.I.S.N	Solar Electronics Co.	8012-50-R-24 BNC	50 - 60 Hz
Equipment Testing Turn Table	EMCO	1061-06	
Antenna Positioning Tower	EMCO	1050	
Radio Interference Receiver	PRD Electronics Inc.	R-1040/URM-85	(two complete systems)
Antenna Coupler	PRD Electronics Inc.	Cu-893/URM-85	80 - 220 MHz
Antenna Tripod	PRD Electronics Inc.	MT-2459/URM-85	
Frequency Converter	Empire Devices Products Corp.	CV-1102/URM-85	20 - 220 MHz
Frequency Converter	PRD Electronics Inc.	CV-1104A/URM-85	400 - 1000 MHz
Frequency Converter	PRD Electronics Inc.	CV-1101A/URM-85	0.15 - 30 MHz
Frequency Converter	PRD Electronics Inc.	CV-1103/URM-85	200 - 400 MHz

Title: **PLI Evaluation Report (RFI)**
Drawing: Q514103FCCW.DWG
By: Greg Noll

FCC ID: NCE5141U

Page 11 of 46
Issued: 15 Apr 1999
Approved: Lee Pulver

Equipment Type	Manufacturer	Model Number	Frequency Range
Frequency Converter	PRD Electronics Inc.	CV-1102A/URM-85	20 - 220 MHz
Antenna Coupler (two systems)	PRD Electronics Inc.	CU-890/URM-85	0.15 - 30 MHz
Loop Antenna (two systems)	PRD Electronics Inc.	AT-1026/URM-85	0.15 - 30 MHz
Frequency Comb Generator	Hewlett Packard	8406A	20 - 1200 MHz
Tunable Band Pass Filter	K & L Microwave Inc.	5BT-95/190-5/B	95 - 195 MHz
Tunable Band Pass Filter	K & L Microwave Inc.	5BT-48/95-5/B	50 - 95 MHz
High Pass Filter	Solar Electronics Co.	7801-5.0	5 kHz
Absorbing Clamp	Schaffner EMC Inc.	MDS-21	30 - 1000 MHz
Line Probe	EMCO	3701	
Antenna Set	EMCO	3121C	30 - 1000 MHz
L.I.S.N	Solar Electronics Co.	8328-50-TS-50-N	
Frequency Generator		TS-418B/U	400 - 1000 MHz
Frequency Generator		TS-510A/U	10 - 420 MHz

Title: **PLI Evaluation Report (RFI)**
Drawing: Q514103FCCW.DWG
By: Greg Noll

FCC ID: NCE5141U

Page 12 of 46
Issued: 15 Apr 1999
Approved: Lee Pulver

Equipment Type	Manufacturer	Model Number	Frequency Range
Antenna Set	Electro-Metrics	TDA-25	30 - 200 MHz
Antenna Set	Electro-Metrics	TDS-25-1	200 - 500 MHz
Antenna Set	Electro-Metrics	TDS-25-2	500 - 1000 MHz
Antenna (two sets)	PRD Electronics Inc.	AT-1030/URM-85	400 - 1000 MHz
Coupler Antenna	PRD Electronics Inc.	CU-895/URM-85	20 - 1000 MHz
Electronic Field Probe	PRD Electronics Inc.	MX-3411/URM-85	0.15 - 1000 MHz
Fixed Attenuator	PRD Electronics Inc.	CN-721/URM-85	0.15 - 1000 MHz
Magnetic Field Probe	PRD Electronics Inc.	MX-3412/URM-85	20 - 1000 MHz
Coupler	PRD Electronics Inc.	CU-896/URM-85	20 - 1000 MHz
Coupler	PRD Electronics Inc.	CU-897/URM-85	20 - 1000 MHz
Ground Rod	PRD Electronics Inc.	GP-117/URM-85	
Coupler Antenna	PRD Electronics Inc.	CU-894/URM-85	200 - 400 MHz
Reflector Antenna	PRD Electronics Inc.	AT-1027/URM-85	0.15 - 30 MHz

Title: **PLI Evaluation Report (RFI)**
Drawing: Q514103FCCW.DWG
By: Greg Noll

FCC ID: NCE5141U

Page 13 of 46
Issued: 15 Apr 1999
Approved: Lee Pulver

Equipment Type	Manufacturer	Model Number	Frequency Range
Cable Assembly Set	PRD Electronics Inc.	MX-3410/URM-85	
Cord Assembly	PRD Electronics Inc.	CX-4305/U	
Mega Cycle Tape	Disston Carlson	TM6625-351-12-8	17 - 1000 MHz
Antenna Discone	Empire Devices Products Corp.	AS-1158/URM-85	Broad Band
Headset	Empire Devices Products Corp.	H-113/U	
Mast Sections	Empire Devices Products Corp.	AB-21/GR	
Antenna Tripod			
EMI Line Filter	Stanford Applied Engineering	D30B	50 - 60 Hz 3 phase
Digital Power Meter	Fluke and Phillips	FLUKE 39	
Multimeter	Fluke and Phillips	FLUKE 87 True RMS	
Feed Through Caps	Solar Electronics Co.	6512-106 R 10 microfarad capacitors	275V RMS, 60 Hz
Multimeter	Beckman Industrial Corp.	Circuitmate DM15B	250V RMS, 400 Hz
RMS Multimeter	Beckman Industrial Corp.	Tech 310	

Title: **PLI Evaluation Report (RFI)**
Drawing: Q514103FCCW.DWG
By: Greg Noll

FCC ID: NCE5141U

Page 14 of 46
Issued: 15 Apr 1999
Approved: Lee Pulver

Equipment Type	Manufacturer	Model Number
Multimeter	Fluke and Phillips	FLUKE 85
RMS Multimeter	Fluke and Phillips	FLUKE 87
ELF Field Monitor	Walker Magnetic Group	ELF 50D
RMS Multimeter	Fluke and Phillips	FLUKE 87

Title: **PLI Evaluation Report (RFI)** **FCC ID: NCE5141U**
Drawing: Q514103FCCW.DWG
By: Greg Noll

Page 15 of 46
Issued: 15 Apr 1999
Approved: Lee Pulver

- 1.6 List of Exhibits accompanying the FCC submission to help describe and clarify the Equipment Under Test.
 - 1.6.1 Schematics or detailed block diagrams.
 - 1.6.2 Equipment manual for operator or user showing enough detail to operate the equipment.
 - 1.6.3 Currently dated and originally signed FCC Application for Certification (Form 731) along with the FCC Certification fee.
 - 1.6.4 Current Agent Authorization letter.
 - 1.6.5 Proposed identification label representative of the production label to be placed on the equipment upon grant of the application. Positioned on equipment as shown in block rough in Section 2.1 of this report.

2.0 Mandatory Labeling and Operators' Manual Information and Shipping Documents

2.1 FCC Label

Illustration 1.0 on the next page illustrates the actual FCC label (three times the actual size) with the appropriate wording. Note the letters "EMI" on the label which abbreviate "Electromagnetic Interference". Organizations like the Federal Communications Commission and their respective limits are listed on the label.

Also notice the letters "NRTL", which abbreviate "Nationally Recognized Testing Laboratory" as recommended by OSHA and the National Electrical Code for the United States. For Pulver Laboratories product Certification labels used for safety Certification, the phrase "SAFETY" appears on the label. Safety Certifying organizations like Pulver Laboratories are listed on the label adjacent to the testing standards used during equipment evaluation.

A rough sketch of the label location is shown below.

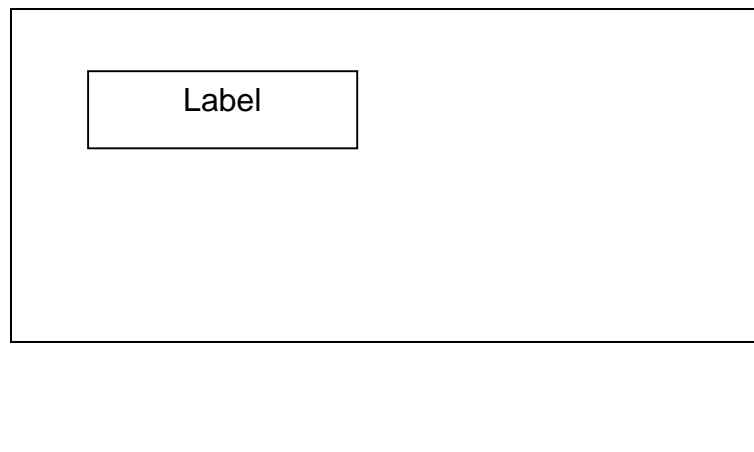

Circuit side of EUT

Title: **PLI Evaluation Report (RFI)**
Drawing: Q514103FCCW.DWG
By: Greg Noll

FCC ID: NCE5141U

Page 17 of 46
Issued: 15 Apr 1999
Approved: Lee Pulver

Illustration 1.0
{three times the size of actual FCC Label}

Label

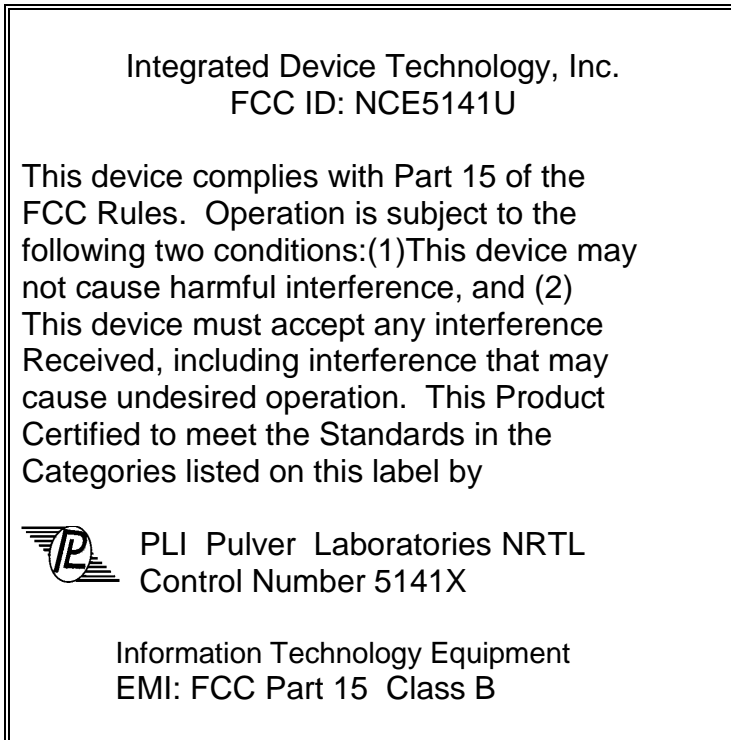

2.2 **Operators' Manual Information**

2.2.1 The following information is inserted directly into the equipment user instruction manual to meet the requirements of product safety and Radio Frequency Interference (RFI) rules and regulations.

CAUTION - Use low voltage shielded computer data cables to connect peripherals (like printers and modems) to the computer.

WARNING - A non-shielded power cord may be used to connect AC power to the host computer.

2.2.2 **Continuation of FCC label information:**

Integrated Devices Technology, Inc. may decide to use a smaller FCC label. In this instance, the following phrase must be added to the Operator's Manual:

"This device complies with Part 15 of the FCC Rules. Operation is subject to the following two conditions: (1) this device may not cause harmful interference, and (2) this device must accept any interference received, including interference that may cause undesired operation."

2.3 **FCC User Information** - The following statements are placed in the front of the operators' manual so that the user of the EUT is aware of its interference potential. Additional information about corrective measures may also be provided to the user at the manufacturer's option.

Title:
Drawing:
By:

PLI Evaluation Report (RFI) **FCC ID: NCE5141U**
Q514103FCCW.DWG
Greg Noll

Page 19 of 46
Issued: 15 Apr 1999
Approved: Lee Pulver

For a Class B Digital Device or Peripheral

**FCC NOTICE
INFORMATION FOR THE USER**

This equipment has been tested and found to comply with the limits for a Class B digital device, pursuant to Part 15 of the FCC Rules. These limits are designed to provide reasonable protection against harmful interference in a residential installation. This equipment generates, uses and can radiate radio frequency energy and, if not installed and used in accordance with the instructions, may cause harmful interference to radio communications. However, there is no guarantee that interference will not occur in a particular installation. If this equipment does cause harmful interference to radio or television reception, which can be determined by turning the equipment off and on, the user is encouraged to try to correct the interference by one or more of the following measures:

- 1) Reorient or relocate the receiving antenna.
- 2) Increase the separation between the equipment and receiver.
- 3) Connect the equipment into an outlet on a circuit different from that to which the receiver is connected.
- 4) Consult the dealer or an experienced radio/TV technician for help.

The user may find the following publication prepared by the Federal Communications Commission helpful:

"How to Identify and Resolve Radio-TV Interference Problems" (Stock Number 004-000-00345-4).

Available exclusively from the Superintendent of Documents, Government Printing Office, Washington, DC 20402 (telephone 202-512-1800).

FCC WARNING

Changes or modifications not expressly approved by the party responsible for compliance to Part 15 of the FCC Rules could void the user's authority to operate the equipment.

Title: **PLI Evaluation Report (RFI)**
Drawing: Q514103FCCW.DWG
By: Greg Noll

FCC ID: NCE5141U

Page 20 of 46
Issued: 15 Apr 1999
Approved: Lee Pulver

This page intentionally blank.

Title: **PLI Evaluation Report (RFI)** **FCC ID: NCE5141U**
Drawing: Q514103FCCW.DWG
By: Greg Noll

Page 21 of 46
Issued: 15 Apr 1999
Approved: Lee Pulver

FIGURE 1: PLI Photograph Number 991607 illustrates the rear view of the Host Computer containing the Equipment Under Test, with all peripherals attached in Test Configuration #1. Shown in the foreground is the Sender/Receiver Computer System. The "open field" radiated and the "screen room" conducted Radio Frequency Interference / Electromagnetic Interference test programs utilized this equipment and cable configuration.

Title: **PLI Evaluation Report (RFI)**
Drawing: Q514103FCCW.DWG
By: Greg Noll

FCC ID: NCE5141U

Page 22 of 46
Issued: 15 Apr 1999
Approved: Lee Pulver

This page intentionally blank.

Title: **PLI Evaluation Report (RFI)** **FCC ID: NCE5141U**
Drawing: Q514103FCCW.DWG
By: Greg Noll

Page 23 of 46
Issued: 15 Apr 1999
Approved: Lee Pulver

FIGURE 2: PLI Photograph Number 991608 illustrates the rear view of the Host Computer System containing the Equipment Under Test with all peripherals attached in Test Configuration #1. The "open field" radiated and the "screen room" conducted Radio Frequency Interference / Electromagnetic Interference test programs utilized this equipment and cable configuration.

Title: **PLI Evaluation Report (RFI)**
Drawing: Q514103FCCW.DWG
By: Greg Noll

FCC ID: NCE5141U

Page 24 of 46
Issued: 15 Apr 1999
Approved: Lee Pulver

This page intentionally blank.

Title: **PLI Evaluation Report (RFI)** **FCC ID: NCE5141U** Page 25 of 46
Drawing: Q514103FCCW.DWG Issued: 15 Apr 1999
By: Greg Noll Approved: Lee Pulver

FIGURE 3: PLI Photograph Number 991609 illustrates the left oblique view of the Host Computer containing the Equipment Under Test with all peripherals attached in the “screen room” conducted Electromagnetic Interference Test Configuration #1.

Title: **PLI Evaluation Report (RFI)**
Drawing: Q514103FCCW.DWG
By: Greg Noll

FCC ID: NCE5141U

Page 26 of 46
Issued: 15 Apr 1999
Approved: Lee Pulver

This page intentionally blank.

Title: **PLI Evaluation Report (RFI)** **FCC ID: NCE5141U**
Drawing: Q514103FCCW.DWG
By: Greg Noll

Page 27 of 46
Issued: 15 Apr 1999
Approved: Lee Pulver

FIGURE 4: PLI Photograph Number 991610 illustrates the top view of the Host Computer with the top cover removed showing the placement of the installed Equipment Under Test inside the computer, and reflecting the placement of the internal ribbon cables attaching the Equipment Under Test to the motherboard and associated internal system components.

Title: **PLI Evaluation Report (RFI)**
Drawing: Q514103FCCW.DWG
By: Greg Noll

FCC ID: NCE5141U

Page 28 of 46
Issued: 15 Apr 1999
Approved: Lee Pulver

This page intentionally blank.

Title: **PLI Evaluation Report (RFI)**
Drawing: Q514103FCCW.DWG
By: Greg Noll

FCC ID: NCE5141U

Page 29 of 46
Issued: 15 Apr 1999
Approved: Lee Pulver

FIGURE 5: PLI Photograph Number 991406 illustrates the component side of the 155 Mbps ATM Adapter Card, Model 7M925, Serial number 00E0CF003A20 rev B1.

Title: **PLI Evaluation Report (RFI)**
Drawing: Q514103FCCW.DWG
By: Greg Noll

FCC ID: NCE5141U

Page 30 of 46
Issued: 15 Apr 1999
Approved: Lee Pulver

This page intentionally blank.

Title: **PLI Evaluation Report (RFI)**
Drawing: Q514103FCCW.DWG
By: Greg Noll

FCC ID: NCE5141U

Page 31 of 46
Issued: 15 Apr 1999
Approved: Lee Pulver

FIGURE 6: PLI Photograph Number 991407 illustrates the circuit side of the 155 Mbps ATM Adapter Card, Model 7M925, Serial number 00E0CF003A20 rev B1.

Title: **PLI Evaluation Report (RFI)**
Drawing: Q514103FCCW.DWG
By: Greg Noll

FCC ID: NCE5141U

Page 32 of 46
Issued: 15 Apr 1999
Approved: Lee Pulver

**Block Diagram of Equipment Under Test (EUT)
Showing Clock Oscillators and Frequencies of Operation**

Crystal Oscillator U2 19.44 MHz	Crystal Oscillator U3 80.00 MHz
---------------------------------------	---------------------------------------

**Use this diagram to simplify locating the oscillators
in the accompanying schematics.**

Equipment Under Test Orientation and Configuration

Zero Degrees

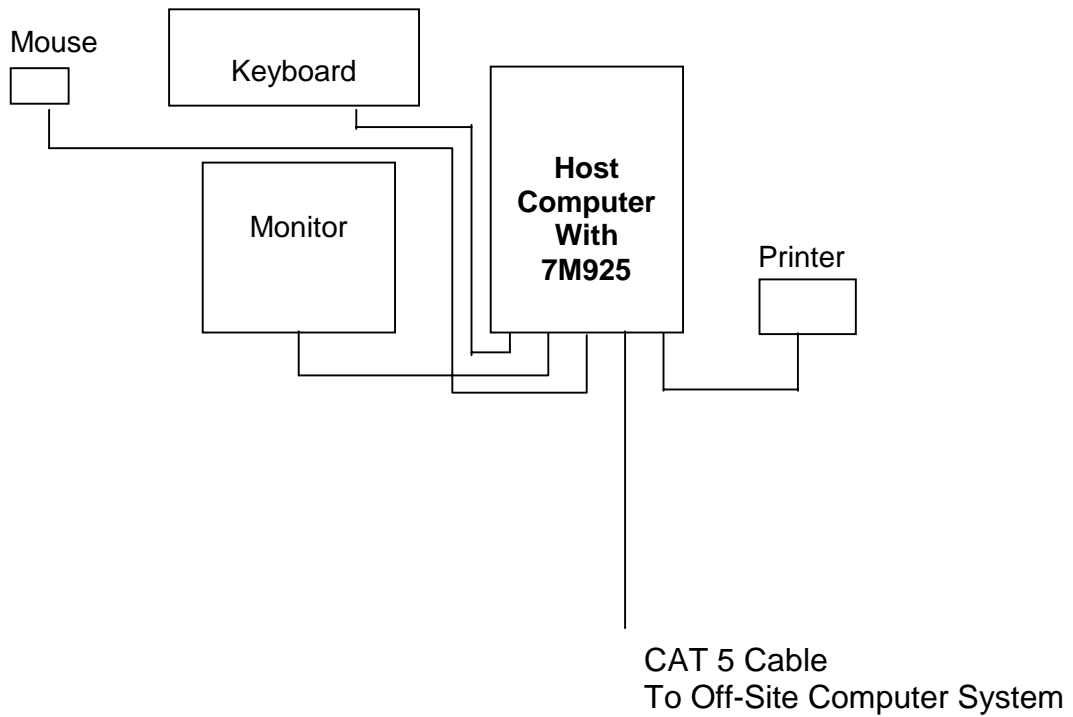

180 Degrees

3.0 Radiated Electromagnetic Interference (EMI) - Test Configuration

- 3.1 PLI placed the Equipment Under Test (EUT) on an 80 centimeter high table located on a 12.70 millimeter (0.5 inch) thick, 1.83 meter (6.00 foot) diameter, remote controlled steel turntable positioned 3.00 meters away from a receiving antenna assembly. This steel gear driven turntable has a 2400 pound capacity. The grounded turntable top surface is flush with a grounded screen consisting of 6.35 millimeter (0.25 inch) squares forming a wire mesh. The automated 4.00 meter mast and antenna assembly connects to an RF amplifier attached to a spectrum analyzer with quasi-peak adapter.
- 3.2 The Equipment Under Test (EUT) was operated at its specified load condition for which it was designed. After 30 minutes of continuous operation, the EUT reached normal operating temperature. Recorded EMI data in this report was accumulated during the normal load and operating temperature of the EUT.
- 3.3 The EUT and system configuration follows:
- 3.3.1 The EUT was placed inside the Host Computer. Peripherals were attached to the computer system. This entire system was placed on the test table surface in accordance with ANSI C63.4-1992.
- 3.3.2 To re-iterate, the 155 Mbps ATM Adapter Card, Model 7M925, was plugged into the Host Computer. The Host Computer was connected to an external monitor, mouse, printer, and keyboard. It was also connected to a Sender/Receiver computer via a UTP CAT5 (8-wire) data cable. The Host Computer was booted up and a Windows 98 operating system was loaded.
- 3.3.3 The Sender/Receiver Computer (also containing a 7M925) was connected to a monitor and keyboard with internal mouse. The Sender/Receiver Computer was booted up and Windows 95 operating system was loaded.
- 3.3.4 Data transfer initiated with the following procedure:
- The program "VXD Load" was loaded and initiated.
 - The program "DRV Test" was loaded and initiated.
 - Programs "Cell Gen" and "Cell Rec" were loaded and initiated.
 - Data transfer was activated throughout the entire test period.

Title: **PLI Evaluation Report (RFI)**
Drawing: Q514103FCCW.DWG
By: Greg Noll

FCC ID: NCE5141U

Page 35 of 46
Issued: 15 Apr 1999
Approved: Lee Pulver

3.3.5 The following equipment list defines the system configuration:

On-Site Host Computer with EUT:

EUT #1 : 155 Mbps ATM Adapter Card
Model Number : 7M925
Serial Number : 00E0CF003A20
FCC ID Number : NCE5141U (proposed)
Manufacturer : Integrated Device Technology, Inc.

Product : Aspire Computer System
Model Number : AS3200
Serial Number : 45AB703001
FCC ID Number : Tested to Comply With FCC Standards
(DoC Authorized)
Manufacturer : Acer

Product : 14" Color Monitor
Model Number : CVP-5468NI
Serial Number : A50-30200357
FCC ID Number : DBLCVP-5468NI
Manufacturer : CTX International Inc.

Product : Aspire Keyboard
Model Number : 6511-HA
Serial Number : 9122H070818NP22121S00000
FCC ID Number : Tested to Comply With FCC Standards
(DoC Authorized)
Manufacturer : Acer Peripherals Inc.

Product Name : Microline 192 Printer
Model Number : GE5251B
Serial Number : 510A0112915
FCC ID Number : BDB9F2192
Manufacturer : Okidata

Product Name : Aspire Mouse
Model Number : MUSXT-1A
Serial Number : 81103995
FCC ID Number : Tested to Comply With FCC Standards
(DoC Authorized)

Title: **PLI Evaluation Report (RFI)**
Drawing: Q514103FCCW.DWG
By: Greg Noll

FCC ID: NCE5141U

Page 36 of 46
Issued: 15 Apr 1999
Approved: Lee Pulver

Manufacturer : Acer Peripherals Inc.
Product Name : UTP CAT5 DR Cable (8-wire)
Model Number : Systimax 2061C4-24
Serial Number : None
FCC ID Number : None
Manufacturer : AT&T

Off-Site Sender/Receiver Computer

Product : Sender/Receiver Computer System
Model Number : None
Serial Number : 200301-89
FCC ID Number : None
Manufacturer : Sun Business Systems

Product : Color Display Monitor
Model Number : SM584
Serial Number : 6B500616
FCC ID Number : KTASM584
Manufacturer : 3G Technologies Inc.

Product : Mighty Keyboard (with internal mouse)
Model Number : KT-30M
Serial Number : M-9013976
FCC ID Number : F2Q4NEKT-30
Manufacturer : Qtronix Corporation

- 3.4 The Equipment Under Test was evaluated per the American National Standards Institute standard number C63.4-1992 entitled Methods of Measurement of Radio-Noise Emissions from Low-Voltage Electrical and Electronic Equipment in the Range of 9 kHz to 40 GHz. To maximize Electromagnetic Interference signal strength, PLI rotated the System Under Test 360 degrees and then adjusted the receiving antenna height until the maximum signal appeared on the spectrum analyzer. The input/output interface cables between units of the system were always positioned to yield maximum field strength.

4.0 Radiated EMI – Results

- 4.1 The investigated frequency spectrum revealed radiated EMI signals. The highest interference in the horizontal polarization occurred when the front of the unit was facing 180 degrees clockwise with respect to the antenna. The highest interference in the vertical polarization occurred when the front of the unit was facing 180 degrees clockwise with respect to the antenna.
- 4.2 The "ACF" (Antenna Correction Factor) shown in the test data in this report includes compensation for the antenna factor; cable attenuation; the series RF attenuator; the RF amplifier; and pre-selector system losses. The spectrum analyzer data is shown as quasi-peak amplitudes.
- 4.3 The test facility is FCC registered; the procedures are CISPR registered, ICAN registered, VCCI registered, VDE approved, and BZT approved.

Type of Test	Radiated Electromagnetic Interference
Specification	FCC Class B
Date Data Collected	14 April 1999
Detection Technique	Spectrum Analyzer with Quasi-peak Adapter
Resolution Bandwidth	100 kHz
Video Bandwidth	100 kHz
Antennas	30 to 200 MHz High Field Biconical 200 to 1000 MHz Log-Periodic

Title: **PLI Evaluation Report (RFI)**
Drawing: Q514103FCCW.DWG
By: Greg Noll

FCC ID: NCE5141U

Page 38 of 46
Issued: 15 Apr 1999
Approved: Lee Pulver

Test Configuration #1

Frequency MHz	EMI Data dBµV/M	ACF	Field Strength dBµV/M	FCC Limit dBµV/M	Margin to Limit dBµV/M
Horizontal					
48.00	34.80	-9.88	24.92	40.00	-15.08
61.25	36.10	-10.96	25.14	40.00	-14.86
72.70	44.30	-12.69	31.61	40.00	-8.39
83.98	36.50	-14.17	22.33	40.00	-17.67
85.93	36.20	-14.27	21.93	40.00	-18.07
108.75	27.80	-11.17	16.63	43.50	-26.87
115.30	41.00	-10.09	30.91	43.50	-12.59
133.33	35.90	-9.83	26.07	43.50	-17.43
137.80	36.00	-9.94	26.06	43.50	-17.44
150.35	41.10	-9.27	31.83	43.50	-11.67
171.85	36.30	-9.58	26.72	43.50	-16.78
195.43	33.80	-10.31	23.49	43.50	-20.01
240.08	38.20	-8.72	29.48	46.00	-16.52
288.05	34.50	-5.72	28.78	46.00	-17.22
300.70	32.20	-5.60	26.60	46.00	-19.40
333.18	31.10	-6.06	25.04	46.00	-20.96
450.03	32.90	-1.80	31.10	46.00	-14.90
551.28	31.10	-1.00	30.10	46.00	-15.90
589.80	24.50	-0.67	23.83	46.00	-22.17
639.25	36.60	-0.66	35.94	46.00	-10.06
670.75	27.40	0.41	27.81	46.00	-18.19
706.78	29.50	1.83	31.33	46.00	-14.67
868.50	22.40	4.25	26.65	46.00	-19.35
933.33	30.20	5.54	35.74	46.00	-10.26

Title: **PLI Evaluation Report (RFI)**
Drawing: Q514103FCCW.DWG
By: Greg Noll

FCC ID: NCE5141U

Page 39 of 46
Issued: 15 Apr 1999
Approved: Lee Pulver

Test Configuration #1

Frequency MHz	EMI Data dBμV/M	ACF	Field Strength dBμV/M	FCC Limit dBμV/M	Margin to Limit dBμV/M
Vertical					
36.00	44.40	-8.66	35.74	40.00	-4.26
39.93	42.90	-8.93	33.97	40.00	-6.03
47.98	40.60	-9.88	30.72	40.00	-9.28
61.28	39.00	-10.96	28.04	40.00	-11.96
80.00	40.60	-13.98	26.62	40.00	-13.38
85.98	40.50	-14.27	26.23	40.00	-13.77
114.53	41.40	-10.22	31.18	43.50	-12.32
124.03	31.30	-9.49	21.81	43.50	-21.69
150.35	43.60	-9.27	34.33	43.50	-9.17
168.55	31.50	-9.73	21.77	43.50	-21.73
171.85	33.60	-9.58	24.02	43.50	-19.48
194.28	27.40	-10.06	17.34	43.50	-26.16
200.00	35.70	-11.30	24.40	43.50	-19.10
240.03	34.10	-8.73	25.37	46.00	-20.63
311.08	30.80	-5.75	25.05	46.00	-20.95
432.13	32.30	-2.26	30.04	46.00	-15.96
486.85	32.80	-1.37	31.43	46.00	-14.57
528.10	30.10	-1.10	29.00	46.00	-17.00
585.28	37.50	-0.70	36.80	46.00	-9.20
643.78	31.10	-0.67	30.43	46.00	-15.57
733.35	28.50	1.37	29.87	46.00	-16.13
771.28	31.80	1.61	33.41	46.00	-12.59
866.70	24.80	4.22	29.02	46.00	-16.98
949.05	23.80	5.85	29.65	46.00	-16.35

4.4 **Calculations and Notes Concerning Data Presentation**

4.4.1 "ACF" means the Antenna Correction Factor for either Horizontal or Vertical antenna orientation.

4.4.2 "H" means Horizontal antenna orientation.

4.4.3 "V" means Vertical antenna orientation.

4.4.4 "*" means the "Margin to Limit" Exceeds the "EN Limit" and/or Exceeds the "FCC Limit" or is within a -2 dB μ V margin.

4.4.5 "A" designates an ambient signal.

4.4.6 "(-.-)" means the signal level as lower than the adjacent data or within the background ambients.

4.4.7 "EMI DATA" plus "ACF" equals "Field Strength".

4.4.8 "Field Strength" minus "EN Limit" and/or minus "FCC Limit" equals "Margin to Limit".

4.4.9 "Margin to Limit" negative numbers show Equipment Under Test "Field Strength" below the "EN Limit" and/or below the "FCC Limit". "Margin to Limit" positive numbers show Equipment Under Test "Field Strength" above the "EN Limit" and/or above the "FCC Limit".

4.5 The field strengths in this section were measured at 3.0 meters. None of the Electromagnetic Interference quasi-peaks are in excess of the FCC (Federal Communications Commission) Class B maximums, even when the field strength readings in the above table are reduced by 20 dB μ V (to represent 30 meter test site measurements, since an antenna positioned at 30.0 meters receives one tenth of the field strength recorded at 3.0 meters).

4.6 **Conclusion** - The radiated Electromagnetic Interference of the Equipment Under Test meets the requirements for Federal Communications Commission (FCC) Class B devices.

5.0 Conducted EMI - Test Configuration

- 5.1 Current input power leads of the Equipment Under Test were connected to a Line Impedance Stabilization Network (LISN), which isolate and couple the conducted interference from the power lines to a spectrum analyzer. The LISN and the Equipment Under Test were connected and positioned according to the Industry Canada and the Federal Communications Commission test recommendations. The Equipment Under Test was configured exactly as outlined in the Radiated Electromagnetic Interference Section of this report. The spectrum analyzer data is shown in the following table as quasi-peak amplitudes.
- 5.2 To increase data integrity and also meet the recommendations of the American National Standards Institute standard number C63.4-1992, all electrical devices comprising the system being tested with the Equipment Under Test were connected to the VAC mains using a second Line Impedance Stabilization Network.

6.0 Conducted EMI – Results

- 6.1 Investigation of the EUT revealed conducted interference levels as shown in the table below.

Type of Test	Conducted Electromagnetic Interference
Specification	FCC Class B
Date Data Collected	14 April 1999
Detection Technique	Spectrum Analyzer with Quasi-peak Adapter
Frequency Range	0.450 to 30.0 MHz
Resolution Bandwidth	10 kHz
Video Bandwidth	10 kHz
Line Impedance Stabilization Network	50 micro Henry; 50 ohm

Title: **PLI Evaluation Report (RFI)**
Drawing: **Q514103FCCW.DWG**
By: **Greg Noll**

FCC ID: NCE5141U

Page 42 of 46
Issued: 15 Apr 1999
Approved: Lee Pulver

Test Configuration #1

Frequency MHz	Line Data dBµV	Neutral Data dBµV	FCC Limit dBµV	Margin to Limit (Line) dBµV	Margin to Limit (Neutral) dBµV
0.48	32.20	34.90	48.00	-15.80	-13.10
0.75	28.20	30.50	48.00	-19.80	-17.50
1.33	30.30	23.90	48.00	-17.70	-24.10
2.78	28.40	-.	48.00	-19.60	-.
3.13	-.	25.40	48.00	-.	-22.60
4.82	20.60	-.	48.00	-27.40	-.
5.43	26.40	-.	48.00	-21.60	-.
6.11	28.00	-.	48.00	-20.00	-.
7.06	35.00	-.	48.00	-13.00	-.
8.69	30.80	-.	48.00	-17.20	-.
9.51	30.40	-.	48.00	-17.60	-.
11.07	20.30	27.80	48.00	-27.70	-20.20
13.91	34.30	-.	48.00	-13.70	-.
14.53	40.60	-.	48.00	-7.40	-.
16.88	39.80	-.	48.00	-8.20	-.
17.09	-.	39.20	48.00	-.	-8.80
19.55	41.20	39.20	48.00	-6.80	-8.80
20.16	41.00	-.	48.00	-7.00	-.
21.80	-.	36.70	48.00	-.	-11.30
23.56	-.	26.80	48.00	-.	-21.20
24.45	37.90	-.	48.00	-10.10	-.
25.48	28.70	32.90	48.00	-19.30	-15.10
27.52	38.00	-.	48.00	-10.00	-.
29.78	28.70	28.90	48.00	-19.30	-19.10

6.2 **Calculations and Notes Concerning Data Presentation**

- 6.2.1 "*" means the "Margin to Limit" Exceeds the "FCC Limit" and/or Exceeds the "EN Limit" or is within a -2 dB μ V margin.
- 6.2.2 "(-.-)" means the signal level as lower than the adjacent data or within the background ambients.
- 6.2.3 "Line Data" minus "FCC Limit" and/or minus "EN Limit" equals "Margin to Limit" for the Line side of the input power cord.
- 6.2.4 "Neutral Data" minus "FCC Limit" and/or minus "EN Limit" equals "Margin to Limit" for the Neutral side of the input power cord.
- 6.2.5 "Margin to Limit" negative numbers show Equipment Under Test "Field Strength" **below** the "FCC Limit" and/or **below** the "EN Limit". "Margin to Limit" positive numbers show Equipment Under Test "Field Strength" **above** the "FCC Limit" and/or **above** the "EN Limit".
- 6.2.6 "A" means an Ambient signal.
- 6.2.7 The symbol " Σ " adjacent to a line of conducted Electromagnetic Interference data means that the "Field Strength" was recorded directly as a quasi-peak measurement, and then reduced by 13 dB μ V. The data obtained in quasi-peak mode was 6 dB μ V or higher than the level of the same emission measured with the spectrum analyzer detector function set to the average mode. The emission was considered broadband, since the quasi-peak mode bandwidth setting was identical to the average mode bandwidth setting. 100 samples were recorded represented by the following equation:

$$(1 / n) \sum_{i=1}^n x_i$$

- 6.3 **Conclusion** - The conducted Electromagnetic Interference of the Equipment Under Test meets the requirements for Federal Communications Commission (FCC) Class B devices.
- 6.4 Graphs of PEAK conducted Electromagnetic Interference for frequency ranges on Line and Neutral are shown on the following pages.

- 6.5 The recorded conducted data utilized a quasi-peak measurement procedure. Hence, any differences between the graphs and the data are merely the differences between peak and quasi-peak measurements.
- 6.6 There are 33 AM and 56 FM radio stations in the immediate San Jose, California, area which create large ambient signals. Typical radio stations are:
- 0.810 MHz KGO
 - 1.170 MHz KLOK
 - 1.370 MHz KEEN
 - 1.500 MHz KHTT
 - 1.590 MHz KLIV
- 6.7 The conducted Electromagnetic Interference graphs in this report show some of the large ambient signals for several of these radio stations.
- 6.8 The final Electromagnetic Interference conducted test and measurement equipment configuration was evaluated to assure that Data Compression or Intermodulation Distortion did not occur due to these large ambient signals.

Title: **PLI Evaluation Report (RFI)** **FCC ID: NCE5141U**
Drawing: Q514103FCCW.DWG
By: Greg Noll

Page 45 of 46
Issued: 15 Apr 1999
Approved: Lee Pulver

FCC Conducted Photographs

Line Lead
0.15 to 30.00 MHz

Neutral Lead
0.15 to 30.00 MHz

Title: **PLI Evaluation Report (RFI)** **FCC ID: NCE5141U**
Drawing: Q514103FCCW.DWG
By: Greg Noll

Page 46 of 46
Issued: 15 Apr 1999
Approved: Lee Pulver

**Signature Page - Last Page of Report
&This document for Electronic Transmittal Only&**

Project Coordinated by

Signed _____
Laura A. Bramschreiber

Data and Technical Details by

Signed _____
Greg Noll

Quality Assurance by

Signed _____
Kate Wolf

Report Approved by

Signed _____
Lee J. Pulver