

Gantner Electronic GmbH

TEST REPORT

SCOPE OF WORK

RADIO TESTING – SUB CONTROL UNIT -[GAT NET.CONTROLLER S 7020 BA NU]

REPORT NUMBER

2245283KAU-007a

ISSUE DATE

26-August-2022

PAGES

39

DOCUMENT CONTROL NUMBER

R_FCC 15-225_21-11 (15-November-2021)

© 2017 INTERTEK



TYPE: GAT NET.Controller S 7020 BA NU
DESCRIPTION: **Sub Control unit for electronic locker locks**
SERIAL NO: **2150060125**

All measurement results refer to the equipment which was tested

MANUFACTURER: Gantner Electronic GmbH
CUSTOMER NAME: Gantner Electronic GmbH
ADDRESS (CUSTOMER): Bundesstr. 12
6714 Nüziders
Austria

REPORT NO: 2245283KAU-007a

TEST RESULT: The equipment complies to 47 CFR Part 15, Subpart C, Intentional radiators for 13.56 MHz RFID module, section 15.207, 15.225 / RSS-210, Issue 10 and RSS-GEN, Issue 5 (Referring to the operating modes specified in this report).

TEST LABORATORY: Intertek Deutschland GmbH
Innovapark 20, 87600 Kaufbeuren
Germany

FCC DESIGNATION NUMBER: DE0014

FCC TEST FIRM REGISTRATION NUMBER: 359260

ISED CAB IDENTIFIER: DE0014
ISED #: 24854

TEST ENGINEER: M. Bensaid
Project Engineer

REVIEWER: U. Gronert
Senior Project Engineer





Details about Accreditations/Acceptances

EMC / Radio National

| | |
|---|--|
|  | <p>The Intertek Deutschland EMC-Lab is accredited by the Deutsche Akkreditierungsstelle GmbH (DAkKS)</p> |
| | <p>Registration Number (EMC general): D-PL-12085-01-01</p> |
| | <p>Registration Number (EMC Med): D-PL-12085-01-03</p> |
| | <p>Registration Number (EMC Canada): D-PL-12085-01-04</p> |
| | <p>Registration Number (EMC FCC): D-PL-12085-01-05</p> |

International

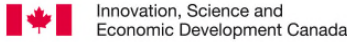
| | |
|---|---|
|  | <p>The Intertek Deutschland EMC-Lab is accepted to participate in the IECEE (IEC Conformity assessment for Electrotechnical Equipment and Components) CB-Scheme</p> <p>CB Test Laboratory: TL118</p> |
|  | <p>The Intertek Deutschland EMC-Lab is accredited for the Federal Communications Commission (FCC)</p> <p>Designation Number: DE0014 Test Firm Registration Number: 359260</p> |
|  | <p>The <i>Bundesnetzagentur</i> recognizes Intertek Deutschland GmbH as Conformity Assessment Body in the sector electromagnetic compatibility (EMC).</p> <p>BNetzA-CAB-16/21-10</p> |
|  | <p>The Intertek Deutschland EMC-Lab is accredited for Innovation, Science and Economic Development Canada (ISED)</p> <p>ISED CAB IDENTIFIER: DE0014 ISED #: 24854</p> |

Automotive

| | |
|---|--|
|  <p>Anerkennungsstelle</p> <p>Anerkannt unter KBA-P 00046-03</p> | <p>The Intertek Deutschland EMC-Lab is recognized as technical service of the Kraftfahrt-Bundesamt (KBA)</p> <p>Registration Number: KBA-P 00046-03</p> |
|---|--|

SECTION 1
CONTENTS

| | | |
|------------------|--|-----------|
| SECTION 2 | MEASUREMENT AND TEST SPECIFICATION | 5 |
| SECTION 3 | GENERAL INFORMATION | 6 |
| SECTION 4 | SUMMARY OF TESTING | 7 |
| 4.1 | General annotation..... | 7 |
| 4.2 | Identical types..... | 7 |
| 4.3 | Measurement uncertainty..... | 7 |
| 4.4 | Document History..... | 7 |
| SECTION 5 | TEST RESULTS – OVERVIEW | 8 |
| SECTION 6 | INFORMATION ABOUT THE EUT | 9 |
| 6.1 | Description of the EUT..... | 9 |
| 6.2 | Power interface | 10 |
| 6.3 | Configuration mode..... | 11 |
| 6.4 | Operation mode..... | 11 |
| 6.5 | Peripheral devices used for testing | 11 |
| 6.6 | Supply and interconnecting cables used for testing..... | 11 |
| 6.7 | Clock frequencies of the EUT | 11 |
| 6.8 | Block diagram of the test setup..... | 12 |
| SECTION 7 | CONFORMANCE REQUIREMENTS..... | 13 |
| 7.1 | Conducted emissions..... | 13 |
| 7.2 | Field strength 13.110 MHz – 14.010 MHz (Emission Mask) | 19 |
| 7.3 | Radiated emissions < 30 MHz | 23 |
| 7.4 | Radiated emissions 30 MHz to 1 GHz | 27 |
| SECTION 8 | Product identification and compliance information | 31 |
| SECTION 9 | ANNEX | 37 |
| 9.1 | Modifications | 37 |
| 9.2 | Measurement uncertainty evaluation | 38 |

SECTION 2

MEASUREMENT AND TEST SPECIFICATION

47 CFR Part 15, Subpart C, Intentional radiators, section 15.207 and section 15.225 /
RSS-210, Issue 10 and RSS-GEN, Issue 5

The test methods according to: **ANSI C63.10-2013**
American National Standard for Testing Unlicensed Wireless Devices.

The revision of the “Code of Federal Regulations: Title 47 - Chapter I - Subchapter A -
Part 15 Radio Frequency Devices” which was in effect at the time of the first test was
used for testing.

ISED Canada

RSS-210, Issue 10, April 2020

Licence-Exempt Radio Apparatus: Category I
Equipment

RSS-GEN, Issue 5, February 2021

General Requirements for Compliance of Radio
Apparatus

Tests according to:

ANSI C63.10-2013

American National Standard for Testing
Unlicensed Wireless Devices.

No additions, deviations or exclusions have been made from standards and
accreditation.

The test results detailed in this report apply only to the GAT NET.Controller S 7020 BA NU
with the test setup described. Any modification such as a change, addition to or
inclusion of another device into this product will require an additional evaluation.
The support equipment listed as part of the emission tests is required to properly
exercise and test the device under test.

SECTION 3**GENERAL INFORMATION**

Possible test case verdicts:

Test case does not apply to the test object: N/A (Not Applicable)

Test object does meet the requirement: P (Pass)

Test object does not meet the requirements: F (Fail)

Samples arrived: 2022-02-07

Testing: 2022-02-24 to 2022-05-24

Decimal separator: Point Comma

Environmental conditions during testing: Temperature: 15 °C - 35 °C

Humidity: 20 % - 60 %

Atmospheric pressure: 900 mbar - 1000 mbar

If explicitly required by a basic standard the measured climatic conditions are documented in the corresponding test section.

SECTION 4 SUMMARY OF TESTING

4.1 General annotation

The tests were performed in the order of the right column in the “Test Results – Overview” table.

According to the cusomer the 13.56 MHz-RFID module has only one operating mode (send mode).

4.2 Identical types

N/A

4.3 Measurement uncertainty

For each test method an uncertainty evaluation was carried out. The results of the evaluation can be found in the annex of this test report.

4.4 Document History

| REVISION | DATE | REPORT | CHANGES | AUTHOR |
|-----------------|------------|-----------------|---------------|--------|
| Initial release | 2022-08-26 | 2245283KAU-007a | Initial issue | MBE |

SECTION 5

TEST RESULTS – OVERVIEW

| EMISSION | REQUESTED | VERDICT | DATE | NO |
|---|-----------|---------|--------------------------|----|
| Conducted emissions (AC power-line, 0.15 MHz - 30 MHz) | see 7.1 | P | 2022-03-15 2022-05-24 | 4 |
| Field strength (13.110 MHz – 14.010 MHz) | see 7.2 | P | 2022-03-02 | 3 |
| Radiated emissions (< 30 MHz) | see 7.3 | P | 2022-03-02 | 2 |
| Radiated emissions (30 MHz - 1 GHz) | see 7.4 | P | 2022-02-24 | 1 |

SECTION 6

INFORMATION ABOUT THE EUT

6.1 Description of the EUT

table-top EUT floor-standing EUT

| | | | |
|-------------|---------|--------|---------|
| Dimensions: | Height: | Width: | Length: |
| | 42 cm | 133 cm | 310 cm |

Software version: Special Version for Testing

Prototype or Product version: 2.0

Description:
The GAT NET.Controller S 7020 BA NU (SUB Controller unit) is used to connect and control up to 24 electronic locker locks – the GAT NET.Lock 7020. The technology is LEGIC® advent.

Transmitter frequency range: 13.56 MHz

Frequency agile or hopping: Yes No

Antenna: Internal antenna External antenna

Antenna connector: None, internal antenna Yes, type

Type of modulation: ASK

Type of used TAG: GAT Testcard Legic

6.1.1 Photo of the rating plate

Rating plate:



Power supply:



6.2 Power interface

| MODE | VOLTAGE (V) | FREQUENCY (Hz) | COMMENT |
|------|-------------|----------------|-------------------|
| 1 | 120 | 60 | With power supply |

Power sources/associated test equipment

| DEVICE | MANUFACTURER | TYPE | SN | ASSET NO. |
|----------------------|-----------------------|----------|------------|------------|
| 4 quadrant amplifier | Spitzenberger & Spies | PAS 5000 | 826149/005 | PM KF 2555 |

6.3 Configuration mode

| MODE | DESCRIPTION |
|------|---|
| 1 | Three locks were connected to the sub controller unit (sockets: 1, 12 and 24) |

6.4 Operation mode

| MODE | DESCRIPTION |
|------|--|
| 1 | The 13.56 MHz-RFID module was in transmitting mode |
| 2 | Normal operation. The antenna of the 13.56 MHz-RFID module was replaced by a terminating resistor. |

6.5 Peripheral devices used for testing

| DEVICE | MANUFACTURER | TYPE | SN | FCC ID |
|-------------------|-------------------------|------|------------|--------|
| Gat Net Lock 7020 | Gantner Electronic GmbH | - | 2147042103 | - |
| Gat Net Lock 7020 | Gantner Electronic GmbH | - | 2202020284 | - |
| Gat Net Lock 7020 | Gantner Electronic GmbH | - | 2202020267 | - |

6.6 Supply and interconnecting cables used for testing

| LINE | LENGTH (cm) | SHIELDING |
|---|-------------|-----------|
| Cable between controller and lock | 500 | Y |
| Cable between power supply and controller | 35 | N |
| Mains cable | 150 | N |

6.7 Clock frequencies of the EUT

| SOURCE | FREQUENCY () |
|------------|---------------|
| Processor | 24 MHz |
| Crystal Q2 | 32.768 kHz |
| Crystal Q3 | 8 MHz |

6.8 Block diagram of the test setup

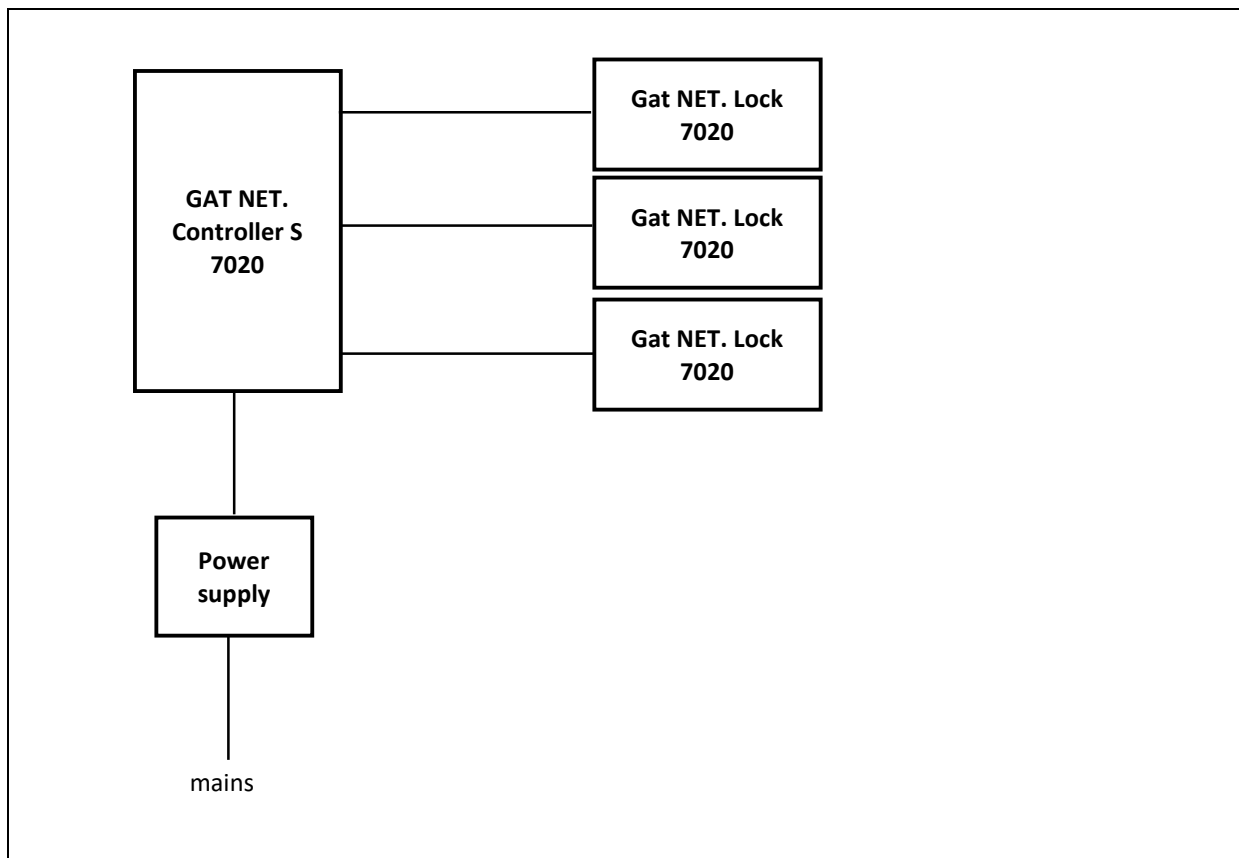

SECTION 7 CONFORMANCE REQUIREMENTS

7.1 Conducted emissions

| NORMATIVE REFERENCES | | RESULT |
|--------------------------------------|--|------------------|
| Limits according to: | FCC §15.207 RSS-210, Issue 9, section | P |
| Methods of measurement according to: | ANSI C63.4 | |
| Equipment mode | Power interface | 120 V / 60 Hz |
| | EUT configuration mode | 1 |
| | Operation mode | 1 and 2 |
| Test requirements | Frequency range | 150 kHz - 30 MHz |

Test equipment

| DESCRIPTION | MANUFACTURER | TYPE | SN | ASSET NO. | CALIBRATION |
|--|-----------------|---------------|-------------|--------------|-------------------|
| Shielded cabin | ETS LINDGREN | RFSD 100 | 3598 | PM KF 2955-2 | - |
| Pulse Limiter 10 dB 9 kHz - 200 MHz | Schwarzbeck | VTSD 9561-F N | 9561-F N242 | PM KF 3059 | 2022-01 (1 year) |
| Receiver 9 kHz - 7 GHz | Rohde & Schwarz | ESR7 | 101757 | PM KF 3371 | 2021-04 (1 year) |
| V-Artificial mains- network, 2 Line | Rohde & Schwarz | ESH3-Z5 | 863367/018 | PM KF 0142 | 2021-08 (2 years) |
| Test software | Rohde & Schwarz | EMC 32 V.8.54 | - | PM KF 2983 | - |

Comment

In the following diagram, the N and L line are merged.

Measurement results – Conducted emissions:

Common Information

EUT: GAT NET.Controller S 7020 BA NU
 Project No.: 45283
 Test description: Conducted Emissions
 Test standard: FCC 15 C
 Tested port: Mains
 Test verdict: Pass
 Operating conditions: The 13.56 MHz-RFID module was in transmitting mode, 120 V, 60 Hz
 Operator name: MBE
 Date of testing: 15.03.2022

EN-CE-R32-LN01

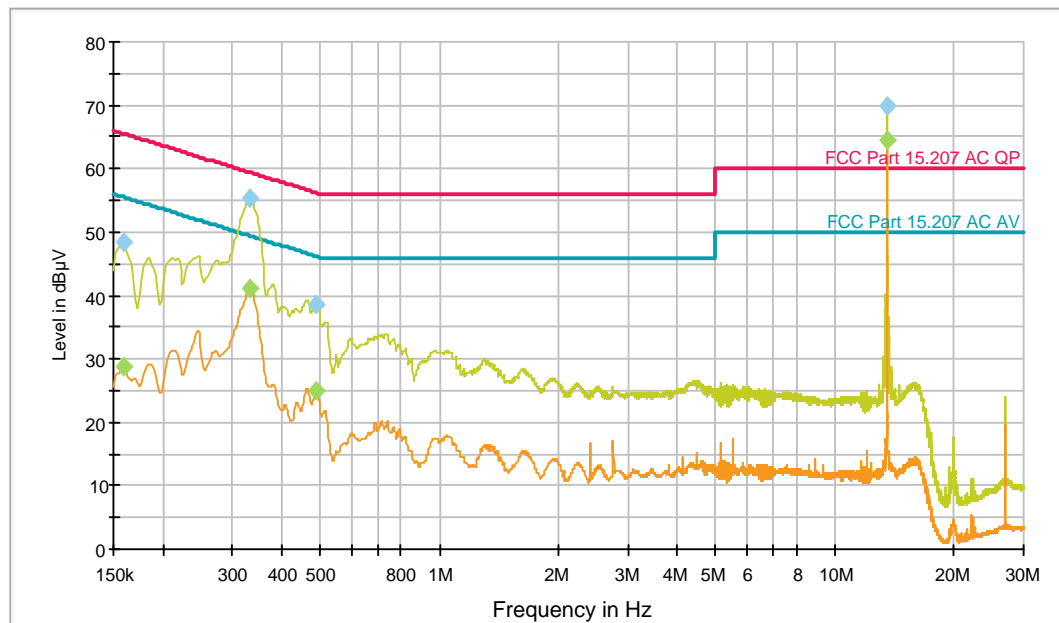

- FCC Part 15.207 AC QP [..\EMI conducted\FCC Part 15 Subpart C\]
- FCC Part 15.207 AC AV [..\EMI conducted\FCC Part 15 Subpart C\]
- Preview Result 1-QPK [Preview Result 1.Result:1]
- Preview Result 2-CAV [Preview Result 2.Result:2]
- ◆ Final Result 1-QPK [Final Result 1.Result:1]
- ◆ Final Result 2-CAV [Final Result 2.Result:1]

Final Result 1

| Frequency (MHz) | QuasiPeak-ClearWrite (dBµV) | PE | Line | Corr. (dB) | Margin (dB) | Limit (dBµV) | Comment |
|-----------------|-----------------------------|-----|------|------------|-------------|--------------|---------|
| 0.159000 | 48.3 | GND | N | 10.3 | 17.3 | 65.5 | |
| 0.332250 | 55.2 | GND | N | 10.4 | 4.2 | 59.4 | |
| 0.489750 | 38.7 | GND | N | 10.4 | 17.5 | 56.2 | |
| 13.560000 | 69.8 | GND | N | 10.8 | -9.8 | 60.0 | |

Final Result 2

| Frequency (MHz) | CAverage-ClearWrite (dBµV) | PE | Line | Corr. (dB) | Margin (dB) | Limit (dBµV) | Comment |
|-----------------|----------------------------|-----|------|------------|-------------|--------------|---------|
| 0.159000 | 28.9 | GND | N | 10.3 | 26.6 | 55.5 | |
| 0.332250 | 41.0 | GND | N | 10.4 | 8.4 | 49.4 | |
| 0.487500 | 25.0 | GND | N | 10.4 | 21.2 | 46.2 | |
| 13.560000 | 64.6 | GND | N | 10.8 | -14.6 | 50.0 | |

EMI Auto Test Template: EN-CE-R32-LN01

Hardware Setup: EN-CE-R32-LN01
 Measurement Type: 2 Line LISN
 Frequency Range: 150 kHz - 30 MHz
 Graphics Level Range: 0 dB μ V - 80 dB μ V

Preview Measurements:
 Scan Test Template: EN-CE-R32-LN01_PRE

| Subrange | Step Size | Detectors | IF BW | Meas. Time | Preamp |
|------------------|-----------|-----------|--------|------------|--------|
| 9 kHz - 150 kHz | 50 Hz | QPK; CAV | 200 Hz | 1 s | 20 dB |
| 150 kHz - 30 MHz | 2.25 kHz | QPK; CAV | 9 kHz | 1 s | 0 dB |

Receiver: [ESR 7]

Data Reduction:
 Limit Line #1: FCC Part 15.207 AC QP
 Limit Line #2: FCC Part 15.207 AC AV
 Peak Search: 6 dB , Maximum Results: 10
 Subrange Maxima: 10 Subranges , Maxima per Subrange: 1
 Acceptance Offset: -10 dB
 Maximum Number of Results: 20
 After Data Reduction: Interactive data reduction

Report Settings:
 Report Template: Standard Report_EMK KF_Conducted Emission

Common Information

EUT: GAT NET.Controller S 7020 BA NU
 Project No.: 45283
 Test description: Conducted Emissions
 Test standard: FCC 15 C
 Tested port: Mains
 Test verdict: Passed
 Operating conditions: Normal operation. The antenna of the 13.56 MHz-RIFD module was replaced by a terminating resistor.
 Operator name: MBE
 Date of testing: 24.05.2022

EN-CE-R32-LN01

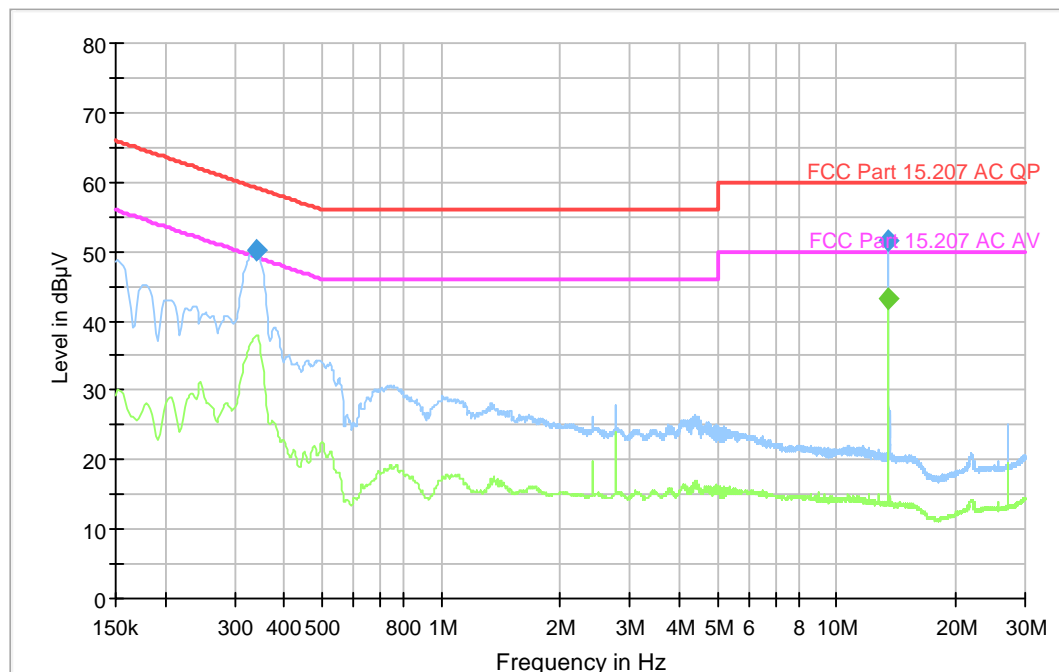

Final Result 1

| Frequency (MHz) | QuasiPeak-ClearWrite (dBµV) | PE | Line | Corr. (dB) | Margin (dB) | Limit (dBµV) | Comment |
|-----------------|-----------------------------|-----|------|------------|-------------|--------------|---------|
| 0.341250 | 50.3 | GND | L1 | 20.3 | 8.9 | 59.2 | |
| 13.560000 | 51.5 | GND | N | 20.8 | 8.5 | 60.0 | |

Final Result 2

| Frequency (MHz) | CAverage-ClearWrite (dBµV) | PE | Line | Corr. (dB) | Margin (dB) | Limit (dBµV) | Comment |
|-----------------|----------------------------|-----|------|------------|-------------|--------------|---------|
| 13.560000 | 43.1 | GND | N | 20.8 | 6.9 | 50.0 | |

EMI Auto Test Template: EN-CE-R32-LN01

Hardware Setup: EN-CE-R32-LN01
 Measurement Type: 2 Line LISN
 Frequency Range: 150 kHz - 30 MHz
 Graphics Level Range: 0 dB μ V - 80 dB μ V

Preview Measurements:
 Scan Test Template: EN-CE-R32-LN01_PRE

| Subrange | Step Size | Detectors | IF BW | Meas. Time | Preamp |
|------------------|-----------|-----------|--------|------------|--------|
| 9 kHz - 150 kHz | 50 Hz | QPK; CAV | 200 Hz | 1 s | 20 dB |
| 150 kHz - 30 MHz | 2.25 kHz | QPK; CAV | 9 kHz | 1 s | 0 dB |

Receiver: [ESR 7]

Data Reduction:
 Limit Line #1: FCC Part 15.207 AC QP
 Limit Line #2: FCC Part 15.207 AC AV
 Peak Search: 6 dB , Maximum Results: 10
 Subrange Maxima: 10 Subranges , Maxima per Subrange: 1
 Acceptance Offset: -10 dB
 Maximum Number of Results: 20
 After Data Reduction: Interactive data reduction

Report Settings:
 Report Template: Standard Report_EMCCF_Conducted Emission

Conducted Emissions

Test procedure:

The test site is a shielded cabin used for conducted emission measurements in the frequency range (9 kHz) 150 kHz – 30 MHz. A reference metal plane is installed on the ground for testing of floor standing devices. In addition, the metal structure of the shielded cabin is used as vertical reference plane for table-top devices. Large floor-standing devices that do not fit into the shielded-cabin are tested in the lab on a reference metal plane.

The system is configured for testing in a typical worst-case fashion (as a customer may use it).

Disturbance voltages on AC and DC lines are measured using an Artificial Mains Network (AMN)/Line Impedance Stabilization Network (LISN). Peripheral devices connected to the EUT are powered via a second LISN terminated with 50 Ohms.

Quasi Peak/Average measurement:

To find the highest interference level in the frequency range (9 kHz) 150 kHz – 30 MHz, in a first step a pre-scan is performed with a quasi-peak and average detector (200 Hz band width below 150 kHz; 9 kHz band width above 150 kHz). Measurement results are generated for all lines (L and N for 1 phase devices; L1, L2, L3 and N for 3 phase devices).

In the next step, frequencies with emissions above the limit or less than 20 dB below the limit are selected by the test personal and a final measurement is conducted. The emission of each critical frequency is measured with CISPR quasi-peak and average detector and documented with the measurement software.

Sample Calculation

The following is how the disturbance voltage is determined:

$$DV = RF + LF + CF + AF$$

Where DV = Disturbance voltage in dB μ V

RF = Reading from receiver in dB μ V

LF = LISN or ISN Correction Factor in dB

CF = Cable Correction Factor in dB

AF = Attenuator Loss Factor in dB

Example:

$$DV = RF + LF + CF + AF = 28.5 + 0.2 + 0.4 + 20.0 = 49.1 \text{ dB}\mu\text{V}$$

7.2 Field strength 13.110 MHz – 14.010 MHz (Emission Mask)

| NORMATIVE REFERENCES | | RESULT |
|--------------------------------------|---|-------------------------|
| Limits according to: | FCC §15.225 (a) – (c) RSS-210, Issue 9, section B4 | P |
| Methods of measurement according to: | ANSI C63.10, section 6.3, 6.4 RSS-Gen 6.13, 8.9 | |
| Equipment mode | Power interface | 120 V / 60 Hz |
| | EUT configuration mode | 1 |
| | Operation mode | 1 |
| Test requirements | Frequency range | 13.110 MHz – 14.010 MHz |
| | Measurement time | 1 s |
| | Antenna height | 1 m |

Limits

The limits below 30 MHz are given for different measurement distances. The measurement values below 30 MHz are converted to 3 m by using the extrapolation factor 40 dB/decade (according to §15.31).

| Frequency (MHz) | Field strength (µV/m) | Field strength (dBµV/m) | Measurement distance (m) |
|-----------------|-----------------------|-------------------------|--------------------------|
| 13.110 - 13.410 | 106 | 40.5 | 30 |
| 13.410 - 13.553 | 334 | 50.5 | 30 |
| 13.553 - 13.567 | 15848 | 84.0 | 30 |
| 13.567 - 13.710 | 334 | 50.5 | 30 |
| 13.710 - 14.010 | 106 | 40.5 | 30 |

Test setup details

Compliance with the spectrum mask is tested using a spectrum analyzer with resolution bandwidth set to 10 kHz or 9 kHz CISPR. The video bandwidth shall be at least three times greater than the resolution bandwidth.

The test was carried out automatically by the test receiver.

The EUT is a table-top EUT and was standing on a table made of Styrodur with a Pertinax plate on top and the dimensions 1.6 m x 1.0 m x 0.8 m (Length x Width x Height).

The emission limits shown in the above table are based on measurements employing a CISPR quasi-peak detector.

Test equipment

| DESCRIPTION | MANUFACTURER | TYPE | SN | ASSET NO. | CALIBRATION |
|-------------------------------|-----------------|----------------------|-----------|---------------|-------------------|
| Semi-Anechoic chamber | Siepel | REF W460SLB | - | PM KF 1150-01 | 2019-12 (3 years) |
| Turntable | Inn-Co | - | - | PM KF 2949-04 | - |
| Tower | Inn-Co | MA4484-XPET | - | PM KF 2949-03 | - |
| Controller | Inn-Co | CO 3000 | 4970815 | PM KF 2949 | - |
| Receiver 9 kHz- 7 GHz | Rohde & Schwarz | ESR7 | 101757 | PM KF 3371 | 2021-04 (1 year) |
| Loop antenna 9 kHz- 30 MHz | Rohde & Schwarz | HFH2-Z2 | 881058/48 | PM KF 1401 | 2021-08 (1 year) |
| Test software | Rohde & Schwarz | EMC 32 V.10.01.00 | - | PM KF 2983-2 | - |

Measurement results – Field strength 13.110 MHz – 14.010 MHz (Emission Mask):

Common Information

| | |
|-----------------------|--|
| EUT: | GAT NET.Controller S 7020 BA NU |
| Test Verdict: | Passed |
| Test Description: | FCC Part 15 C, field strength |
| Operating Conditions: | The 13.56 MHz-RFID module was in transmitting mode, 120 V, 60 Hz |
| Operator Name: | MBE |
| Project Number: | 45283 |
| Date | 02.03.2022 |

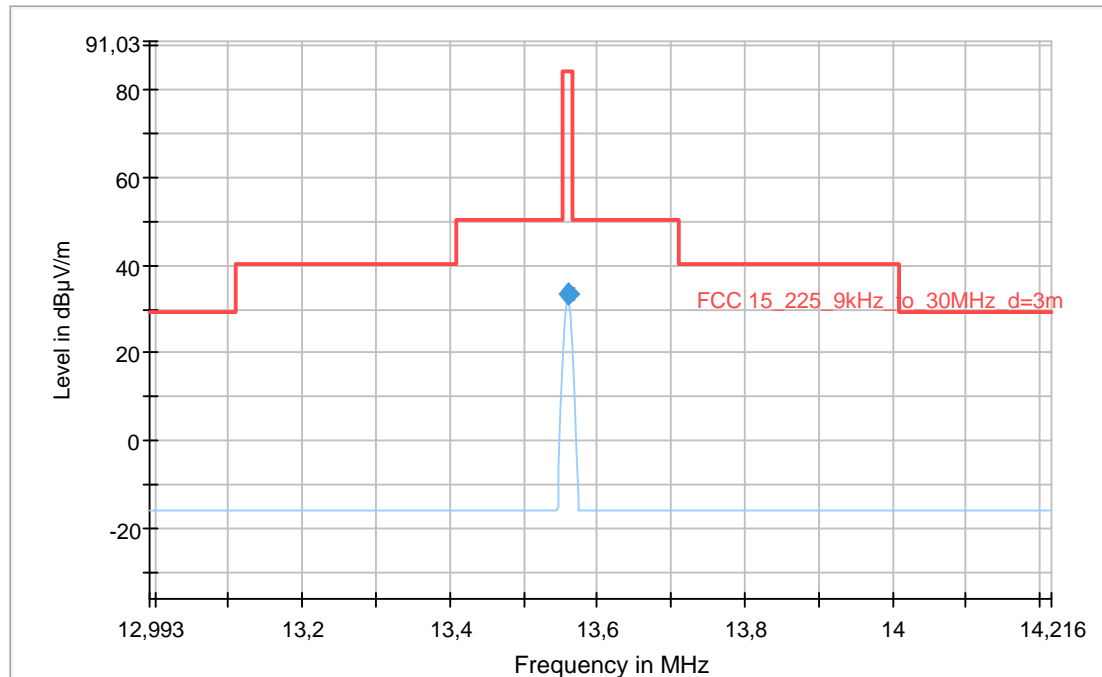

- Preview Result 1-QPK [Preview Result 1.Result:1]
- * Critical_Freqs AVG [Critical_Freqs.Result:5]
- * Critical_Freqs QPK [Critical_Freqs.Result:4]
- FCC 15_225_9kHz_to_30MHz_d=3m [.\zF radiated\FCC Part 15C]
- ◆ Final_Result QPK [Final_Result.Result:4]
- ◆ Final_Result AVG [Final_Result.Result:5]

The RSS-Gen limit in $\mu\text{A/m}$ is essentially equivalent to the FCC 15.209 limit in $\mu\text{V/m}$.

The conversion between E and H is: $H=E-51.5$.

The EUT is also according to RSS-Gen from 9 kHz to 30 MHz pass.

Final_Result

| Frequency (MHz) | QuasiPeak (dBµV/m) | Average (dBµV/m) | Limit (dBµV/m) | Margin (dB) | Meas. Time (ms) | Bandwidth (kHz) | Pol | Azimuth (deg) |
|-----------------|--------------------|------------------|----------------|-------------|-----------------|-----------------|-----|---------------|
| 13.560000 | 31.20 | --- | 84.00 | 52.80 | 1000.0 | 9.000 | H | 154.0 |

(continuation of the "Final_Result" table from column 14 ...)

| Frequency (MHz) | Corr. (dB/m) | Comment |
|-----------------|--------------|-----------------------|
| 13.560000 | -20 | Average: 28.44 dBµV/m |

EMI Auto Test Template: xF-RE-R17-AN23

Hardware Setup: xF-RE-R17-AN23
 Measurement Type: Open-Area-Test-Site (SAC/FAR)
 Frequency Range: 9 kHz - 30 MHz
 Graphics Level Range: -80 dBµV/m - 50 dBµV/m

Preview Measurements:
 Antenna height: 0 - 1000 cm , Step Size = 0 cm , Positioning Speed = 1
 Polarization: H + V
 Turntable position: 0 - 352 deg , Step Size = 22 deg , Positioning Speed = 8
 Scan Test Template: xF-RE-R17-AN23_PRE

| Subrange | Step Size | Detectors | IF BW | Meas. Time | Preamp |
|-------------------|-----------|-----------|--------|------------|--------|
| Receiver: [ESR 7] | | | | | |
| 9 kHz - 150 kHz | 50 Hz | QPK | 200 Hz | 1 s | 0 dB |
| 150 kHz - 30 MHz | 2,25 kHz | QPK | 9 kHz | 1 s | 0 dB |

Anechoic chamber

Test procedure

The test site is an anechoic chamber suitable for radiated emission measurements in the frequency range of 9 kHz – 30 MHz¹⁾. It includes automatic turntable of radius 2 m. It enables manual and fully automatic measurements.

To find the highest level of radiation

- the height of the antenna is 1m with antenna in horizontal and vertical polarization;
- the turntable is rotated in range from 0° to 360°.

The system was configured for testing in a typical worst case fashion (as a customer may use it). All interface cables were moved to determine the position which resulted in the highest emission levels.

Correction factors

The field strength is calculated by adding the antenna factor and cable attenuation. The calculations are performed automatically by the measurement software EMC 32. As example consider the following input values and result:

| FREQUENCY (MHZ) | RECEIVER READING U (dBμV) | ANTENNA FACTOR AF (dB/m) | CABLE ATTENUATION A (dB) | CORRECTION ANTENNA + CABLE (dB) | RADIATED FIELD STRENGTH E (dBμV/m) |
|--------------------|------------------------------------|-----------------------------------|-----------------------------------|--|---|
| 30.0 | 20 | 20.6 | 0.8 | 21.4 | 41.4 |

$$E = U + AF + A$$

1) Comparison field attenuation: free field (OTAS) to anechoic chamber (SAC):

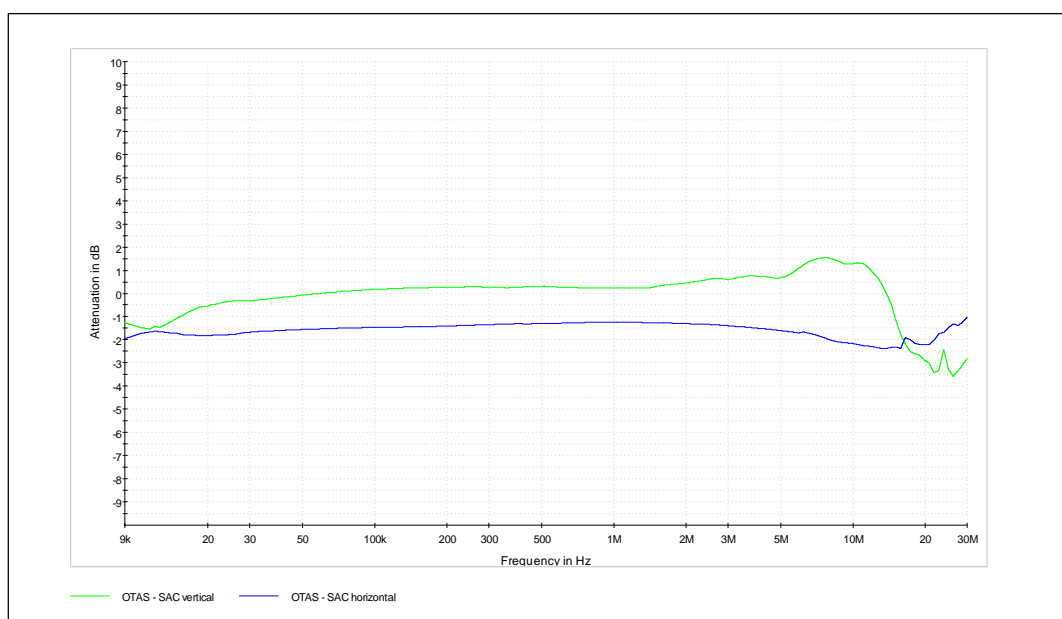

7.3 Radiated emissions < 30 MHz

| NORMATIVE REFERENCES | | RESULT |
|--------------------------------------|--|----------------|
| Limits according to: | FCC §15.225 (d), §15.209 RSS-210, Issue 9, section B4 | P |
| Methods of measurement according to: | ANSI C63.10, section 6.3, 6.4 RSS-Gen 6.13, 8.9 | |
| Equipment mode | Power interface | 120 V / 60 Hz |
| | EUT configuration mode | 1 |
| | Operation mode | 1 |
| Test requirements | Frequency range | 9 kHz - 30 MHz |
| | Antenna height | 1 m |

Limits

The limits below 30 MHz are given for different measurement distances. The measurement values below 30 MHz are converted to 3 m by using the extrapolation factor 40 dB/decade (according to §15.31).

| Frequency (MHz) | Field strength (µV/m) | Field strength (dBµV/m) | Measurement distance (m) |
|-----------------|-----------------------|-------------------------|--------------------------|
| 0.009 - 0.490 | 2400/F(kHz) | 67.6 - 20 · log(F(kHz)) | 300 |
| 0.490 - 1.705 | 24000/F(kHz) | 87.6 - 20 · log(F(kHz)) | 30 |
| 1.705 - 13.110 | 30 | 29.5 | 30 |
| 14.010 - 30.000 | 30 | 29.5 | 30 |

Additionally, the level of any unwanted emissions shall not exceed the level of the fundamental emission.

Test setup details

Compliance with the spectrum mask is tested using a spectrum analyzer with resolution bandwidth set to 10 kHz or 9 kHz CISPR. The video bandwidth shall be at least three times greater than the resolution bandwidth.

The test was carried out automatically by the test receiver.

The EUT is a table-top EUT and was standing on a table made of Styrodur with a Pertinax plate on top and the dimensions 1.6 m x 1.0 m x 0.8 m (Length x Width x Height).

The emission limits shown in the above table are based on measurements employing a CISPR quasi-peak detector except for the frequency bands 9-90 kHz, 110-490 kHz and above 1000 MHz. Radiated emission limits in these three bands are based on measurements employing an average detector.

Test equipment

| DESCRIPTION | MANUFACTURER | TYPE | SN | ASSET NO. | CALIBRATION |
|-------------------------------|-----------------|----------------------|-----------|---------------|-------------------|
| Semi-Anechoic chamber | Siepel | REF W460SLB | - | PM KF 1150-01 | 2019-12 (3 years) |
| Turntable | Inn-Co | - | - | PM KF 2949-04 | - |
| Tower | Inn-Co | MA4484-XPET | - | PM KF 2949-03 | - |
| Controller | Inn-Co | CO 3000 | 4970815 | PM KF 2949 | - |
| Receiver 9 kHz- 7 GHz | Rohde & Schwarz | ESR7 | 101757 | PM KF 3371 | 2021-04 (1 year) |
| Loop antenna 9 kHz- 30 MHz | Rohde & Schwarz | HFH2-Z2 | 881058/48 | PM KF 1401 | 2021-08 (1 year) |
| Test software | Rohde & Schwarz | EMC 32 V.10.01.00 | - | PM KF 2983-2 | - |

Measurement results – Radiated emissions < 30 MHz:

Common Information

| | |
|-----------------------|--|
| EUT: | GAT NET.Controller S 7020 BA NU |
| Test Verdict: | Passed |
| Test Description: | FCC Part 15 C, < 30 MHz |
| Operating Conditions: | The 13.56 MHz-RFID module was in transmitting mode, 120 V, 60 Hz |
| Operator Name: | MBE |
| Project Number: | 45283 |
| Date: | 02.03.2022 |

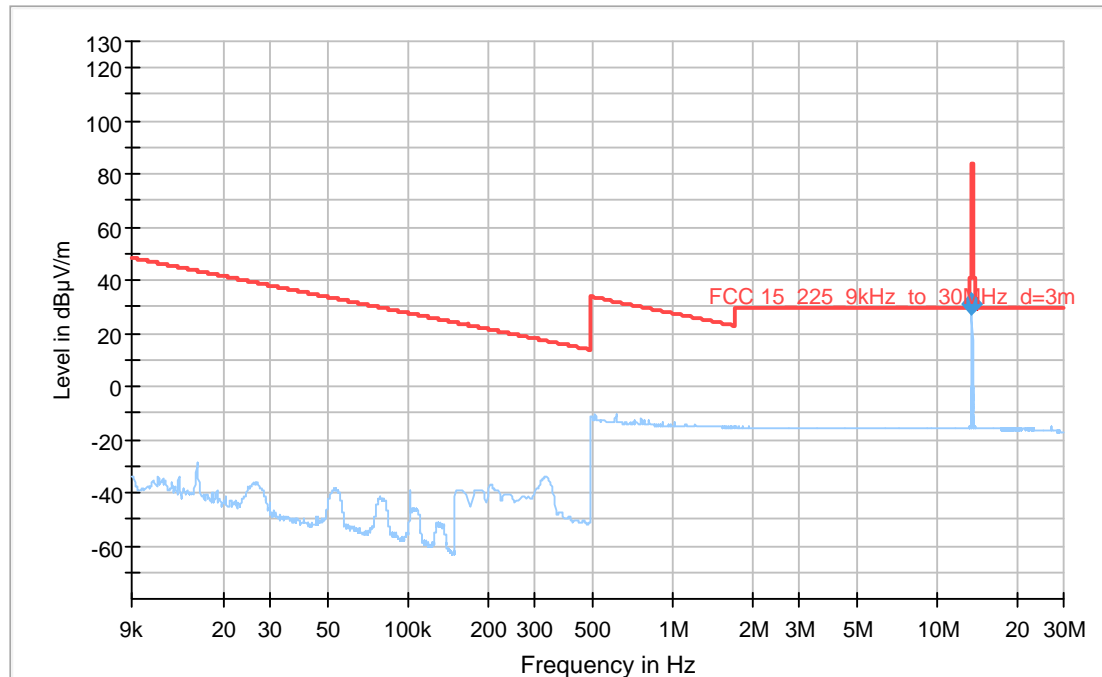

- Preview Result 1-QPK [Preview Result 1.Result:1]
- * Critical_Freqs AVG [Critical_Freqs.Result:5]
- * Critical_Freqs QPK [Critical_Freqs.Result:4]
- FCC 15_225_9kHz_to_30MHz_d=3m [.\zF radiated\FCC Part 15C]
- ◆ Final_Result QPK [Final_Result.Result:4]
- ◆ Final_Result AVG [Final_Result.Result:5]

The RSS-Gen limit in $\mu\text{A/m}$ is essentially equivalent to the FCC 15.209 limit in $\mu\text{V/m}$.
The conversion between E and H is: $H=E-51.5$.
The EUT is also according to RSS-Gen from 9 kHz to 30 MHz pass.

Final_Result

| Frequency (MHz) | QuasiPeak (dBµV/m) | Average (dBµV/m) | Limit (dBµV/m) | Margin (dB) | Meas. Time (ms) | Bandwidth (kHz) | Pol | Azimuth (deg) |
|-----------------|--------------------|------------------|----------------|-------------|-----------------|-----------------|-----|---------------|
| 13.560000 | 31.20 | --- | 84.00 | 52.80 | 1000.0 | 9.000 | H | 154.0 |

(continuation of the "Final_Result" table from column 14 ...)

| Frequency (MHz) | Corr. (dB/m) | Comment |
|-----------------|--------------|-----------------------|
| 13.560000 | -20 | Average: 28.44 dBµV/m |

EMI Auto Test Template: xF-RE-R17-AN23

Hardware Setup: xF-RE-R17-AN23
 Measurement Type: Open-Area-Test-Site (SAC/FAR)
 Frequency Range: 9 kHz - 30 MHz
 Graphics Level Range: -80 dBµV/m - 50 dBµV/m

Preview Measurements:
 Antenna height: 0 - 1000 cm , Step Size = 0 cm , Positioning Speed = 1
 Polarization: H + V
 Turntable position: 0 - 352 deg , Step Size = 22 deg , Positioning Speed = 8
 Scan Test Template: xF-RE-R17-AN23_PRE

| Subrange | Step Size | Detectors | IF BW | Meas. Time | Preamp |
|-------------------|-----------|-----------|--------|------------|--------|
| Receiver: [ESR 7] | | | | | |
| 9 kHz - 150 kHz | 50 Hz | QPK | 200 Hz | 1 s | 0 dB |
| 150 kHz - 30 MHz | 2,25 kHz | QPK | 9 kHz | 1 s | 0 dB |

Anechoic chamber

Test procedure

The test site is an anechoic chamber suitable for radiated emission measurements in the frequency range of 9 kHz – 30 MHz.¹⁾ It includes automatic turntable of radius 2 m. It enables manual and fully automatic measurements.

To find the highest level of radiation

- the height of the antenna is 1m with antenna in horizontal and vertical polarization;
- the turntable is rotated in range from 0° to 360°.

The system was configured for testing in a typical worst case fashion (as a customer may use it). All interface cables were moved to determine the position which resulted in the highest emission levels.

Correction factors

The field strength is calculated by adding the antenna factor and cable attenuation. The calculations are performed automatically by the measurement software EMC 32.

As example consider the following input values and result:

| FREQUENCY (MHZ) | RECEIVER READING U (dBμV) | ANTENNA FACTOR AF (dB/m) | CABLE ATTENUATION A (dB) | CORRECTION ANTENNA + CABLE (dB) | RADIATED FIELD STRENGTH E (dBμV/m) |
|-----------------|---------------------------|--------------------------|--------------------------|---------------------------------|------------------------------------|
| 30.0 | 20 | 20.6 | 0.8 | 21.4 | 41.4 |

$$E = U + AF + A$$

- 1) Comparison field attenuation: free field (OTAS) to anechoic chamber (SAC):

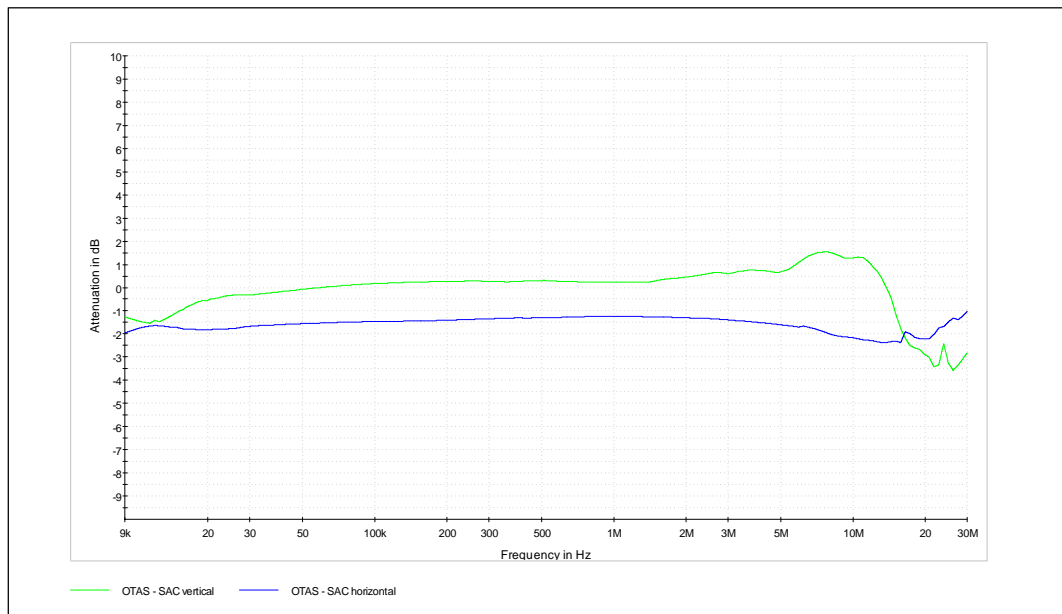

7.4 Radiated emissions 30 MHz to 1 GHz

| NORMATIVE REFERENCES | | RESULT |
|--------------------------------------|--|----------------|
| Limits according to: | FCC §15.225 (d), §15.209 RSS-210, Issue 9, section B4 | P |
| Methods of measurement according to: | ANSI C63.10, section 6.3, 6.5 RSS-Gen 6.13, 8.9 | |
| Equipment mode | Power interface | 120 V / 60 Hz |
| | EUT configuration mode | 1 |
| | Operation mode | 1 |
| Test requirements | Frequency range | 30 MHz - 1 GHz |

Limits

| Frequency (MHz) | Field strength (µV/m) | Field strength (dBµV/m) | Measurement distance (m) |
|-----------------|-----------------------|-------------------------|--------------------------|
| 30 – 88 | 100 | 40.0 | 3 |
| 88 – 216 | 150 | 43.5 | 3 |
| 216 – 960 | 200 | 46.0 | 3 |
| Above 960 | 500 | 54.0 | 3 |

Test setup details

The EUT is a table-top EUT and was standing on a table made of Styrodur with a Pertinax plate on top and the dimensions 1.6 m x 1.0 m x 0.8 m (Length x Width x Height).

Overview sweeps performed with peak detectors and final measurement with quasi-peak detectors. The emission limits shown in the above table are based on measurements employing a CISPR quasi-peak detector.

Test equipment

| DESCRIPTION | MANUFACTURER | TYPE | SN | ASSET NO. | CALIBRATION |
|--------------------------|-----------------|----------------------|---------|---------------|-------------------|
| Semi-Anechoic chamber | Siepel | REF W460SLB | - | PM KF 1150-01 | 2019-12 (3 years) |
| Turntable | Inn-Co | - | - | PM KF 2949-04 | - |
| Tower | Inn-Co | MA4484-XPET | - | PM KF 2949-03 | - |
| Controller | Inn-Co | CO 3000 | 4970815 | PM KF 2949 | - |
| Receiver 9 kHz- 7 GHz | Rohde & Schwarz | ESR7 | 101757 | PM KF 3371 | 2021-04 (1 year) |
| Antenna 30 MHz - 3GHz | Rohde & Schwarz | HL 562 | 100354 | PM KF 1123 | 2020-05 (2 years) |
| Test software | Rohde & Schwarz | EMC 32 V.10.01.00 | - | PM KF 2983-2 | - |

Measurement results – Radiated emissions 30 MHz to 1 GHz:

Common Information

| | |
|-----------------------|--|
| EUT: | GAT NET.Controller S 7020 BA NU |
| Test Verdict: | Passed |
| Test Description: | FCC 15 C, 30-1000 MHz |
| Operating Conditions: | The 13.56 MHz-RFID module was in transmitting mode, 120 V, 60 Hz |
| Operator Name: | RDR |
| Project Number: | 45283 |
| Date | 24.02.2022 |

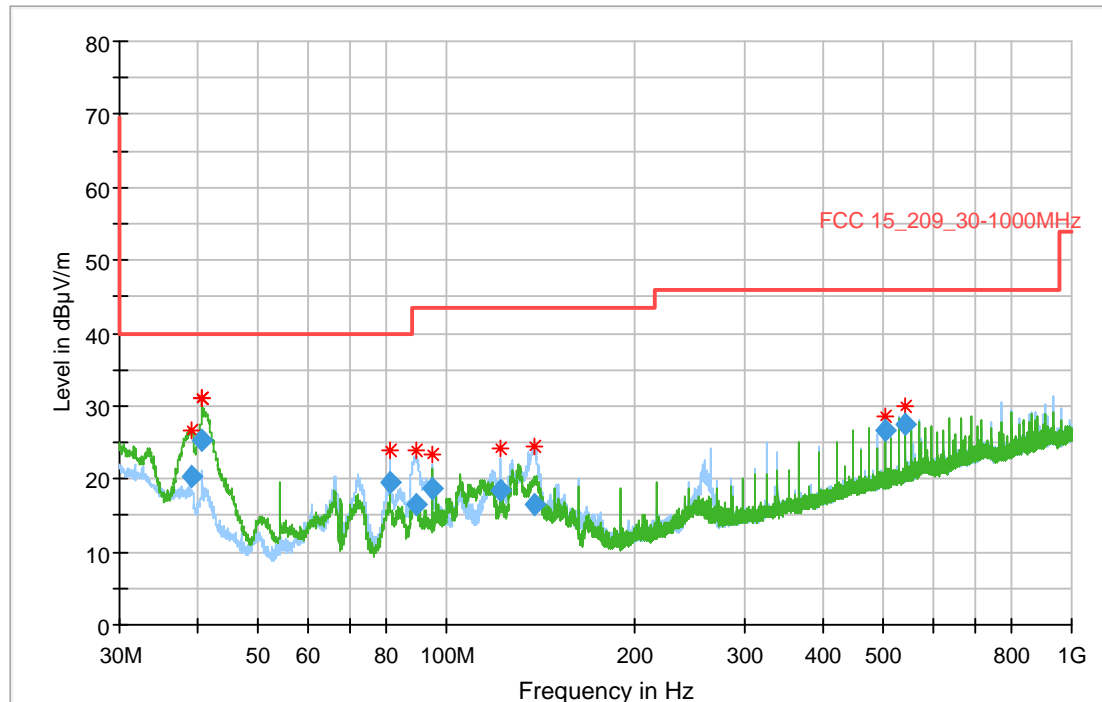

- Preview Result 1H-PK+ [Preview Result 1H.Result:2]
- Preview Result 1V-PK+ [Preview Result 1V.Result:2]
- * Critical_Freqs PK+ [Critical_Freqs.Result:4]
- FCC 15_209_30-1000MHz [..\EMI radiated\FCC Part 15C]
- ◆ Final_Result QPK [Final_Result.Result:4]

Final_Result

| Frequency (MHz) | QuasiPeak (dBµV/m) | Limit (dBµV/m) | Margin (dB) | Meas. Time (ms) | Bandwidth (kHz) | Height (cm) | Pol | Azimuth (deg) |
|-----------------|--------------------|----------------|-------------|-----------------|-----------------|-------------|-----|---------------|
| 39.090000 | 20.22 | 40.00 | 19.78 | 1000.0 | 120.000 | 100.0 | V | 122.0 |
| 40.680000 | 25.34 | 40.00 | 14.66 | 1000.0 | 120.000 | 100.0 | V | 128.0 |
| 81.360000 | 19.44 | 40.00 | 20.56 | 1000.0 | 120.000 | 254.0 | H | 187.0 |
| 89.460000 | 16.46 | 43.52 | 27.06 | 1000.0 | 120.000 | 278.0 | H | 183.0 |
| 94.920000 | 18.73 | 43.52 | 24.79 | 1000.0 | 120.000 | 294.0 | H | 0.0 |
| 122.040000 | 18.32 | 43.52 | 25.20 | 1000.0 | 120.000 | 228.0 | H | 169.0 |
| 138.570000 | 16.51 | 43.52 | 27.01 | 1000.0 | 120.000 | 254.0 | H | 157.0 |
| 501.720000 | 26.61 | 46.02 | 19.41 | 1000.0 | 120.000 | 100.0 | V | 198.0 |
| 542.400000 | 27.61 | 46.02 | 18.41 | 1000.0 | 120.000 | 100.0 | H | 286.0 |

(continuation of the "Final_Result" table from column 15 ...)

| Frequency (MHz) | Corr. (dB/m) | Comment |
|-----------------|--------------|-----------------------|
| 39.090000 | 15 | 23:23:13 - 24.02.2022 |
| 40.680000 | 14 | 23:29:33 - 24.02.2022 |
| 81.360000 | 11 | 23:12:45 - 24.02.2022 |
| 89.460000 | 11 | 23:05:13 - 24.02.2022 |
| 94.920000 | 12 | 23:19:26 - 24.02.2022 |
| 122.040000 | 13 | 23:08:57 - 24.02.2022 |
| 138.570000 | 11 | 23:01:30 - 24.02.2022 |
| 501.720000 | 18 | 23:32:50 - 24.02.2022 |
| 542.400000 | 19 | 22:57:22 - 24.02.2022 |

EMI Auto Test Template: FCC-RE-R17-AN08

Hardware Setup: EN-RE-R12-AN08
 Measurement Type: Open-Area-Test-Site (SAC/FAR)
 Frequency Range: 30 MHz - 1 GHz
 Graphics Level Range: 0 dBµV/m - 80 dBµV/m

Preview Measurements:
 Antenna height: 100 - 355 cm , Step Size = 85 cm , Positioning Speed = 8
 Polarization: H + V
 Turntable position: 0 - 352 deg , Step Size = 22 deg , Positioning Speed = 8
 Graphics Display: Show separate traces for horizontal and vertical polarization
 Scan Test Template: EN-RE-R12-AN08_PRE

| Subrange | Step Size | Detectors | IF BW | Meas. Time | Preamp |
|-------------------|-----------|-----------|---------|------------|--------|
| Receiver: [ESR 7] | | | | | |
| 30 MHz - 1 GHz | 30 kHz | PK+ | 120 kHz | 0,1 s | 20 dB |
| 1 GHz - 3 GHz | 250 kHz | PK+ | 1 MHz | 0,1 s | 20 dB |

Frequency Zoom:
 Zoom Scan Template: EN-RE-R12-AN08_ZOOM

Adjustment:
 Antenna height: Range = 180 cm , Measuring Speed = 1
 Turntable position: Range = 60 deg , Measuring Speed = 2
 Template for Single Meas.: EN-RE-R12-AN08_MAX_1s

Final Measurements:
 Template for Single Meas.: EN-RE-R12-AN08_FIN_15s

| Subrange | Step Size | Detectors | IF BW | Meas. Time | Preamp |
|-------------------|-----------|-----------|---------|------------|--------|
| Receiver: [ESR 7] | | | | | |
| 30 MHz - 200 MHz | 40 kHz | QPK | 120 kHz | 1 s | 20 dB |
| 200 MHz - 1 GHz | 40 kHz | QPK | 120 kHz | 1 s | 20 dB |
| 1 GHz - 3 GHz | 40 kHz | QPK | 1 MHz | 1 s | 20 dB |

Overview sweeps performed with peak detectors and final measurement with quasi-peak detectors.

Anechoic chamber

Test procedure

The test site is an anechoic chamber suitable for radiated emission measurements in the frequency range of 30 MHz – 18 GHz (40 GHz). It includes automatic antenna mast of height 4 m and turntable of radius 2 m. It enables both manual and fully automatic measurements. To find the highest level of radiation

- the height of the antenna is scanned in range 1m to 4 m with antenna in horizontal and vertical polarization;
- the turntable is rotated in range from 0° to 360°.

The system was configured for testing in a typical worst case fashion (as a customer may use it). All interface cables were moved to determine the position which resulted in the highest emission levels.

Correction factors

The field strength is calculated by adding the antenna factor and cable attenuation. The calculations are performed automatically by the measurement software EMC 32. As example consider the following input values and result:

| FREQUENCY (MHZ) | RECEIVER READING U (dBμV) | ANTENNA FACTOR AF (dB/m) | CABLE ATTENUATION A (dB) | CORRECTION ANTENNA + CABLE (dB) | RADIATED FIELD STRENGTH E (dBμV/m) |
|-----------------|---------------------------|--------------------------|--------------------------|---------------------------------|------------------------------------|
| 30.0 | 20 | 20.6 | 0.8 | 21.4 | 41.4 |

$$E = U + AF + A$$

SECTION 8

Product identification and compliance information

FCC, Part 15 C (certification), Product identification and compliance information

Labelling:

§15.19(a)(3):

This device complies with part 15 of the FCC Rules. Operation is subject to the following two conditions: (1) This device may not cause harmful interference, and (2) this device must accept any interference received, including interference that may cause undesired operation.

§15.19(a)(4):

Where a device is constructed in two or more sections connected by wires and marketed together, the statement specified under paragraph (a) of this section is required to be affixed only to the main control unit.

§15.19(a)(5): Small devices

When the device is so small or for such use that it is impracticable to label it with the statement in a font that is four-point or larger, and the device does not have a display that can show electronic labeling, then the information shall be placed in the user manual and must also either be placed on the device packaging or on a removable label attached to the device.

§15.21 Information to user

The user's manual or instruction manual for an intentional or unintentional radiator shall caution the user that changes or modifications not expressly approved by the party responsible for compliance could void the user's authority to operate the equipment. In cases where the manual is provided only in a form other than paper, such as on a computer disk or over the Internet, the information required by this section may be included in the manual in that alternative form, provided the user can reasonably be expected to have the capability to access information in that form.

§15.925 Identification of Equipment

(a) Each equipment covered in an application for equipment authorization shall bear a label listing the following:

(1) FCC Identifier consisting of the two elements in the exact order specified in § 2.926. The FCC Identifier shall be preceded by the term FCC ID in capital letters on a single line, and shall be of a type size large enough to be legible without the aid of magnification.

(2) Any other statements or labeling requirements imposed by the rules governing the operation of the specific class of equipment, except that such statement(s) of compliance may appear on a separate label at the option of the applicant/grantee.

(3) The information required may be provided electronically pursuant to § 2.935.

(b) Any device subject to more than one equipment authorization procedure may be assigned a single FCC Identifier. However, a single FCC Identifier is required to be assigned to any device consisting of two or more sections assembled in a common enclosure, on a common chassis or circuit board, and with common frequency controlling circuits. Devices to which a single FCC Identifier has been assigned shall be identified pursuant to paragraph (a) of this section.

(1) Separate FCC Identifiers may be assigned to a device consisting of two or more sections assembled in a common enclosure, but constructed on separate sub-units or circuit boards with independent frequency controlling circuits. The FCC Identifier assigned to any transmitter section shall be preceded by the term TX FCC ID, the FCC Identifier assigned to any receiver section shall be preceded by the term RX FCC ID and the identifier assigned to any remaining section(s) shall be preceded by the term FCC ID.

(d) In order to validate the grant of equipment authorization, the nameplate or label shall be permanently affixed to the equipment and shall be readily visible to the purchaser at the time of purchase.

(1) As used here, permanently affixed means that the required nameplate data is etched, engraved, stamped, indelibly printed, or otherwise permanently marked on a permanently attached part of the equipment enclosure. Alternatively, the required information may be permanently marked on a nameplate of metal, plastic, or other material fastened to the equipment enclosure by welding, riveting, etc., or with a permanent adhesive. Such a nameplate must be able to last the expected lifetime of the equipment in the environment in which the equipment will be operated and must not be readily detachable.

(2) As used here, readily visible means that the nameplate or nameplate data must be visible from the outside of the equipment enclosure. It is preferable that it be visible at all times during normal installation or use, but this is not a prerequisite for grant of equipment authorization.

(e) A software defined radio may be equipped with a means such as a user display screen to display the FCC identification number normally contained in the nameplate or label. The information must be readily accessible, and the user manual must describe how to access the electronic display.

(f) The FCC Identifier including the term "FCC ID" shall be in a size of type large enough to be readily legible, consistent with the dimensions of the equipment and its label. However, the type size for the FCC Identifier is not required to be larger than eight-point. If a device is so small that it is impractical to label it with the FCC Identifier in a font that is four-point or larger, and the device does not have a display that can show electronic labeling, then the FCC Identifier shall be placed in the user manual and must also either be placed on the device packaging or on a removable label attached to the device.

§15.935 Electronic labeling of radiofrequency devices

(a) Any radiofrequency device equipped with an integrated electronic display screen, or a radiofrequency device without an integrated screen that can only operate in conjunction with a device that has an electronic display screen, may display on the electronic display the FCC Identifier, any warning statements, or other information that the Commission's rules would otherwise require to be shown on a physical label attached to the device.

(b) Devices displaying their FCC Identifier, warning statements, or other information electronically must make this information readily accessible on the electronic display. Users must be provided with prominent instructions on how to access the information in the operating instructions, inserts in packaging material, or other easily accessible format at the time of purchase. The access instructions may also be provided via the product-related Web site, if such a Web site exists; the packaging material must provide specific instructions on how to locate the Web site information, and a copy of these instructions must be included in the application for equipment certification.

(c) Devices displaying their FCC Identifier, warning statements, or other information electronically must permit access to the information without requiring special codes, accessories or permissions and the access to this information must not require more than three steps from the device setting menu. The number of steps does not include those steps for use of screen locks, passcodes or similar security protection designed to control overall device access.

(d) The electronically displayed FCC Identifier, warning statements, or other information must be displayed electronically in a manner that is clearly legible without the aid of magnification;

(e) The necessary label information must be programmed by the responsible party and must be secured in such a manner that third-parties cannot modify it.

(f) Devices displaying their FCC Identifier, warning statements, or other information electronically must also be labeled, either on the device or its packaging, with the FCC Identifier or other information (such as a model number and identification of a Web page that hosts the relevant regulatory information) that permits the devices to be identified at the time of importation, marketing, and sales as complying with the FCC's equipment authorization requirements. Devices can be labeled with a stick-on label, printing on the packaging, a label on a protective bag, or by similar means. Any removable label shall be of a type intended to survive normal shipping and handling and must only be removed by the customer after purchase.

ISED, Certification

Information for user:

“This device contains licence-exempt transmitter(s)/receiver(s) that comply with Innovation, Science and Economic Development Canada’s licence-exempt RSS(s).

Operation is subject to the following two conditions:

1. This device may not cause interference.
2. This device must accept any interference, including interference that may cause undesired operation of the device.

L'émetteur/récepteur exempt de licence contenu dans le présent appareil est conforme aux CNR d'Innovation, Sciences et Développement économique Canada applicables aux appareils radio exempts de licence. L'exploitation est autorisée aux deux conditions suivantes :

1. L'appareil ne doit pas produire de brouillage;
2. L'appareil doit accepter tout brouillage radioélectrique subi, même si le brouillage est susceptible d'en compromettre le fonctionnement.”

RF exposure statement:

“This equipment complies with FCC and ISED Canada radiation exposure limits set forth for an uncontrolled environment. This equipment should be placed and operated with minimum distance 20 cm between the radiator & your body.

Cet équipement est conforme aux limites d'exposition aux radiations fixées par la FCC et ISED Canada pour un environnement non contrôlé. Cet équipement doit être placé et utilisé avec une distance minimale de 20 cm entre le radiateur et votre corps.”

RSS-GEN

4. Labelling requirements

4.1 General

In addition to complying with the applicable RSSs and RSP-100, each unit of a product model (i.e. of a radio apparatus) shall meet the labelling requirements set out in this section prior to being marketed in Canada or imported into Canada.

If the dimensions of the product are extremely small or it is not practical to place the label or marking on the product, and if electronic labelling cannot be implemented, the label shall be placed in a prominent location in the user manual supplied with the product, as agreed upon with ISED prior to the certification application. The user manual may be in an electronic format; if it is not supplied to the user, the user manual must be readily available.

4.2 Labelling of certified products

Every unit of a certified product model, for marketing and use in Canada, shall be identified as per the following requirements:

The HVIN and ISED certification number shall be permanently indicated on the exterior of the product or displayed electronically according to e-labelling requirements (see section 4.4) as follows:

The HVIN and ISED certification number may be placed on a label, which shall be permanently affixed to the product

The ISED certification number shall be preceded by "IC:"

The HVIN may be listed or placed with or without any prefix (HVIN:, Model#, M/N:, P/N:, etc.)

The HVIN and ISED certification number are not required to be adjacent to each other.

The PMN must be displayed electronically (see section 4.4), or indicated on the exterior of the product or on the product packaging, or in the product literature, which shall be supplied with the product or readily available online.

The PMN, HVIN and ISED certification number are permitted to be etched, engraved, stamped, printed on the product, or placed on a label permanently affixed to a permanently attached part of the product.

The PMN, HVIN and ISED certification number indicated on any product (including by electronic display) on the Canadian market must be listed in the REL.

When the FVIN is the only differentiation between product versions (i.e. the PMN and HVIN remain the same for all versions) listed in the REL within a family certification, the FVIN shall be displayed electronically or stored electronically by the product and be easily retrievable.

In all cases, the PMN, FVIN, HVIN and ISED certification number text shall be clearly legible.

The PMN, HVIN, ISED certification number and applicable FVIN are not required to be adjacent to each other.

4.3 Module (Category I) and host product labelling requirements

Any product for which Modular Approval (MA) or Limited Modular Approval (LMA) is being sought shall meet the labelling requirements in section 4.2.

The Host Marketing Name (HMN) shall be displayed according to the e-labelling requirements of section 4.4 or indicated on the exterior of the host product or on the product packaging, or in the product literature, which shall be supplied with the host product or readily available online.

The host product shall be properly labelled to identify the modules within the host product.

The ISED certification label of a module shall be clearly visible at all times when installed in the host product; otherwise, the host product must be labelled to display the ISED certification number for the module, preceded by the word "contains" or similar wording expressing the same meaning, as follows:

Contains IC: XXXXXX-YYYYYYYYYYY

In this case, XXXXXX-YYYYYYYYYYY is the module's certification number.

For each certified module, the applicant shall provide the user with a host label as described above, or a description of the host product labelling requirements.

4.4 Electronic labelling (e-labelling)

Devices with an integrated display screen may have the required label information represented electronically in an e-label instead of on a physical label or nameplate.

Devices without an integrated display screen may have the labelling information represented through an audio message or a host device display screen connected by a physical connection, Bluetooth, Wi-Fi, or other, if the connection to a device with a display is mandatory for use.

Devices using e-labelling shall meet the requirements specified in annex B of this standard.

SECTION 9
ANNEX

9.1 Modifications

N/A

9.2 Measurement uncertainty evaluation

| | |
|---|----------|
| Measurement uncertainty for radiated magnetic field, 9 kHz – 30 MHz | ± 3.9 dB |
| Measurement uncertainty for radiated emission, 30 MHz - 1000 MHz | |
| Uncertainty for the frequency range 300 to 1000 MHz using a logperiodic or a combination antenna at 3 m | ± 4.7 dB |
| Measurement uncertainty for conducted emissions, LISN, 150 kHz -30 MHz | ± 2.3 dB |

End of test report